



Rail Accident Investigation Branch

Rail Accident Report



**Runaway of 'ironmen' trolleys and subsequent
near miss at Raven level crossing, Garnant,
Carmarthenshire
1 November 2014**

Report 13/2015
August 2015

This investigation was carried out in accordance with:

- the Railway Safety Directive 2004/49/EC;
- the Railways and Transport Safety Act 2003; and
- the Railways (Accident Investigation and Reporting) Regulations 2005.

© Crown copyright 2015

You may re-use this document/publication (not including departmental or agency logos) free of charge in any format or medium. You must re-use it accurately and not in a misleading context. The material must be acknowledged as Crown copyright and you must give the title of the source publication. Where we have identified any third party copyright material you will need to obtain permission from the copyright holders concerned. This document/publication is also available at www.raib.gov.uk.

Any enquiries about this publication should be sent to:

RAIB	Email: enquiries@raib.gov.uk
The Wharf	Telephone: 01332 253300
Stores Road	Fax: 01332 253301
Derby UK	Website: www.gov.uk/raib
DE21 4BA	

This report is published by the Rail Accident Investigation Branch, Department for Transport.

Preface

The purpose of a Rail Accident Investigation Branch (RAIB) investigation is to improve railway safety by preventing future railway accidents or by mitigating their consequences. It is not the purpose of such an investigation to establish blame or liability. Accordingly, it is inappropriate that RAIB reports should be used to assign fault or blame, or determine liability, since neither the investigation nor the reporting process has been undertaken for that purpose.

The RAIB's findings are based on its own evaluation of the evidence that was available at the time of the investigation and are intended to explain what happened, and why, in a fair and unbiased manner.

Where the RAIB has described a factor as being linked to cause and the term is unqualified, this means that the RAIB has satisfied itself that the evidence supports both the presence of the factor and its direct relevance to the causation of the accident. However, where the RAIB is less confident about the existence of a factor, or its role in the causation of the accident, the RAIB will qualify its findings by use of the words 'probable' or 'possible', as appropriate. Where there is more than one potential explanation the RAIB may describe one factor as being 'more' or 'less' likely than the other.

In some cases factors are described as 'underlying'. Such factors are also relevant to the causation of the accident but are associated with the underlying management arrangements or organisational issues (such as working culture). Where necessary, the words 'probable' or 'possible' can also be used to qualify 'underlying factor'.

Use of the word 'probable' means that, although it is considered highly likely that the factor applied, some small element of uncertainty remains. Use of the word 'possible' means that, although there is some evidence that supports this factor, there remains a more significant degree of uncertainty.

An 'observation' is a safety issue discovered as part of the investigation that is not considered to be causal or underlying to the event being investigated, but does deserve scrutiny because of a perceived potential for safety learning.

The above terms are intended to assist readers' interpretation of the report, and to provide suitable explanations where uncertainty remains. The report should therefore be interpreted as the view of the RAIB, expressed with the sole purpose of improving railway safety.

The RAIB's investigation (including its scope, methods, conclusions and recommendations) is independent of any inquest or fatal accident inquiry, and all other investigations, including those carried out by the safety authority, police or railway industry.

This page is intentionally left blank

Runaway of ‘ironmen’ trolleys and subsequent near miss at Raven level crossing, Garnant, Carmarthenshire, 1 November 2014

Contents

Summary	7
Introduction	8
Key definitions	8
The incident	9
Summary of the incident	9
Context	11
The sequence of events	15
Key facts and analysis	17
Background information	17
Identification of the immediate cause	19
Identification of causal factors	19
Identification of underlying factor	33
Factor affecting the severity of consequences	34
Observations	34
Previous occurrences of a similar character	35
Previous RAIB recommendation relevant to this investigation	36
Previous recommendation that had the potential to address a factor identified in this report	36
Summary of conclusions	37
Immediate cause	37
Causal factors	37
Underlying factor	37
Additional observations	38
Actions reported as already taken or in progress relevant to this report	39
Actions reported that address factors which otherwise would have resulted in a RAIB recommendation	39
Other reported actions	39
Recommendations	41

Appendices	43
Appendix A - Glossary of abbreviations and acronyms	43
Appendix B - Glossary of terms	44
Appendix C - Investigation details	46
Appendix D - Extract from User Guide – Ironman (Standard and LUL), Ref. MAN/M/O/105	47
Appendix E - Extract from Code of Practice for Rail mounted Manually Propelled Equipment, Ref. CoP0018 issue 5	48
Appendix F - Extracts from Torrent Trackside MS088-01 Lightweight Iron Man Maintenance Sheets, dated 5 September 2014	49
Appendix G - Description of ironman braking system	50

Summary

At about 21:45 hrs on Saturday 1 November 2014 a pair of rail carrying trolleys, known as ironmen, carrying a 16 metre length of rail, ran out of control for approximately 5.4 miles (8.7 km) along the Garnant Branch line in Carmarthenshire. Two track workers rode on the ironmen as far as Raven level crossing (a distance of about one mile) in order to shout a warning to colleagues who were working there; the warning provided just enough time for their colleagues to get clear of the line. The two track workers received minor injuries when they jumped off the ironmen just before the crossing.

The track workers were unable to control the speed of the ironmen on the descending gradient towards Raven level crossing. The incident occurred due to a combination of the planning of the work, the control of the work, the speed at which the ironmen were travelling and the performance of the ironmen's brakes.

The RAIB has made one recommendation to Network Rail, in conjunction with RSSB and the M&E Engineers Networking Group, to improve the design and testing of the brakes of manually propelled plant. It has made three recommendations to Network Rail relating to the planning of work using manually propelled plant, arrangements for compliance with the requirements of the Rule Book, and measures to mitigate the risk of runaway of manually propelled plant. It has made one recommendation to Permaquip, relating to the design and maintenance of the ironman braking system. It has also made one recommendation to Torrent Trackside relating to the maintenance of braking systems fitted to manually propelled plant.

Introduction

Key definitions

- 1 Metric units are used in this report, except when it is normal railway practice to give speeds and locations in imperial units. Where appropriate the equivalent metric value is also given.
- 2 The report contains abbreviations and technical terms (shown in *italics* the first time they appear in the report). These are explained in appendices A and B. Sources of evidence used in the investigation are listed in appendix C.

The incident

Summary of the incident

- 3 At about 21:45 hrs on Saturday 1 November 2014 a pair of rail carrying trolleys known as *ironmen*, carrying a 16 metre length of rail, ran out of control over Raven level crossing (figure 1). The ironmen were being used within an *engineering possession* to transport the rail from an *access point* at Gwaun-Cae-Gurwen (GCG) to Raven level crossing, where two lengths of rail were due to be replaced. The average gradient over this section is 1 in 40 falling.

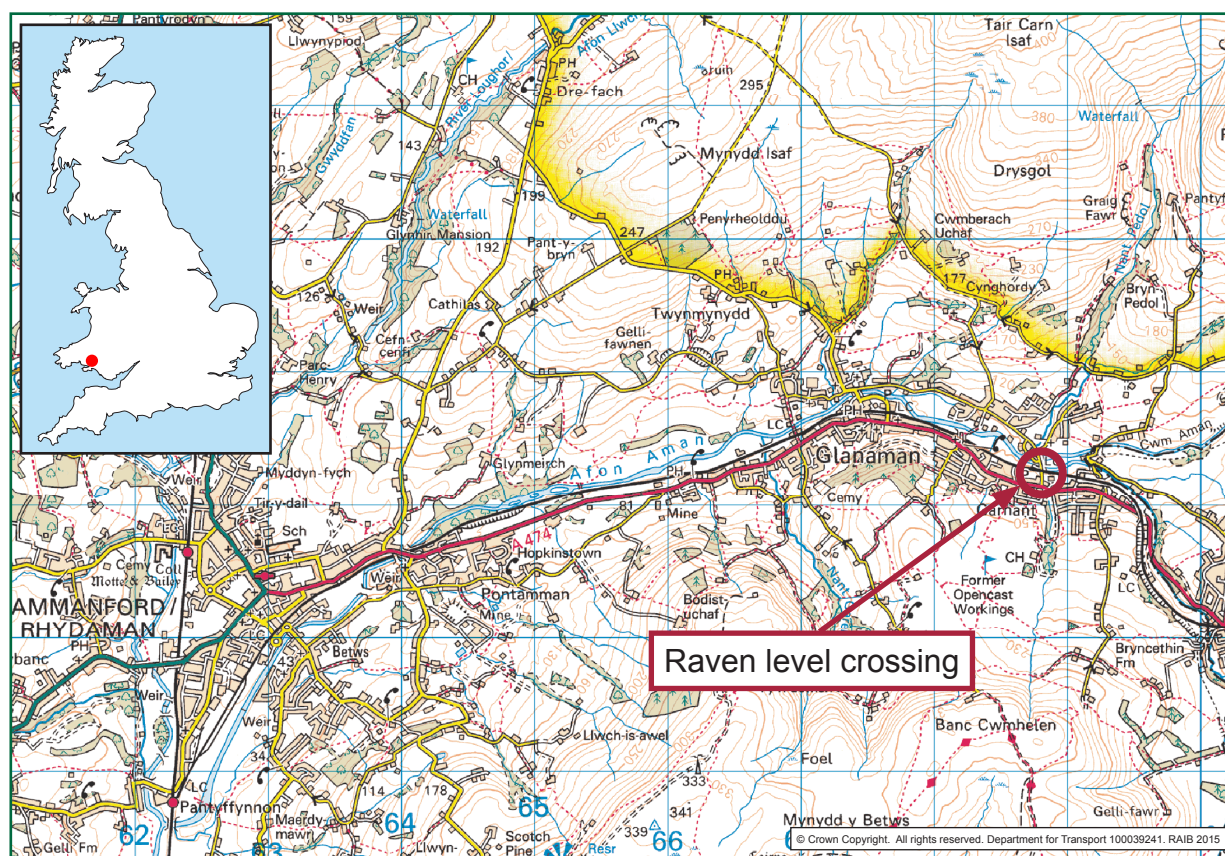

Figure 1: Extract from Ordnance Survey map showing location of the incident

- 4 There were two Network Rail track workers with the pair of ironmen and the length of rail (figure 2), subsequently referred to as the rig. The track workers lost control of the rig shortly after passing GCG level crossing; it then ran along the Garnant Branch line for approximately 5.4 miles (8.7 km) before it was stopped by a Network Rail manager near Garnant Branch level crossing. In addition to Raven level crossing, the rig ran over three road crossings, two of which were open to road traffic, three *user worked crossings* and four footpath crossings. The RAIB estimates that it reached a maximum speed of 19 mph (30 km/h) and that it ran over the four road crossings at speeds of between 15 and 17 mph (24 and 28 km/h)¹.

¹ The maximum permissible speed for rail traffic passing over these road crossings is 10 mph (16.1 km/h).

- 5 Following the loss of control of the rig, the two track workers rode on the ironmen in order to shout a warning to colleagues who were working in the *four foot* at Raven level crossing (figure 3). The warning provided just enough time for their colleagues to get clear of the line. The two track workers then jumped off the ironmen just before the crossing, receiving minor injuries; one was taken to hospital and was later discharged.



Figure 2: View of a pair of ironmen carrying two lengths of rail (courtesy Permaquip)

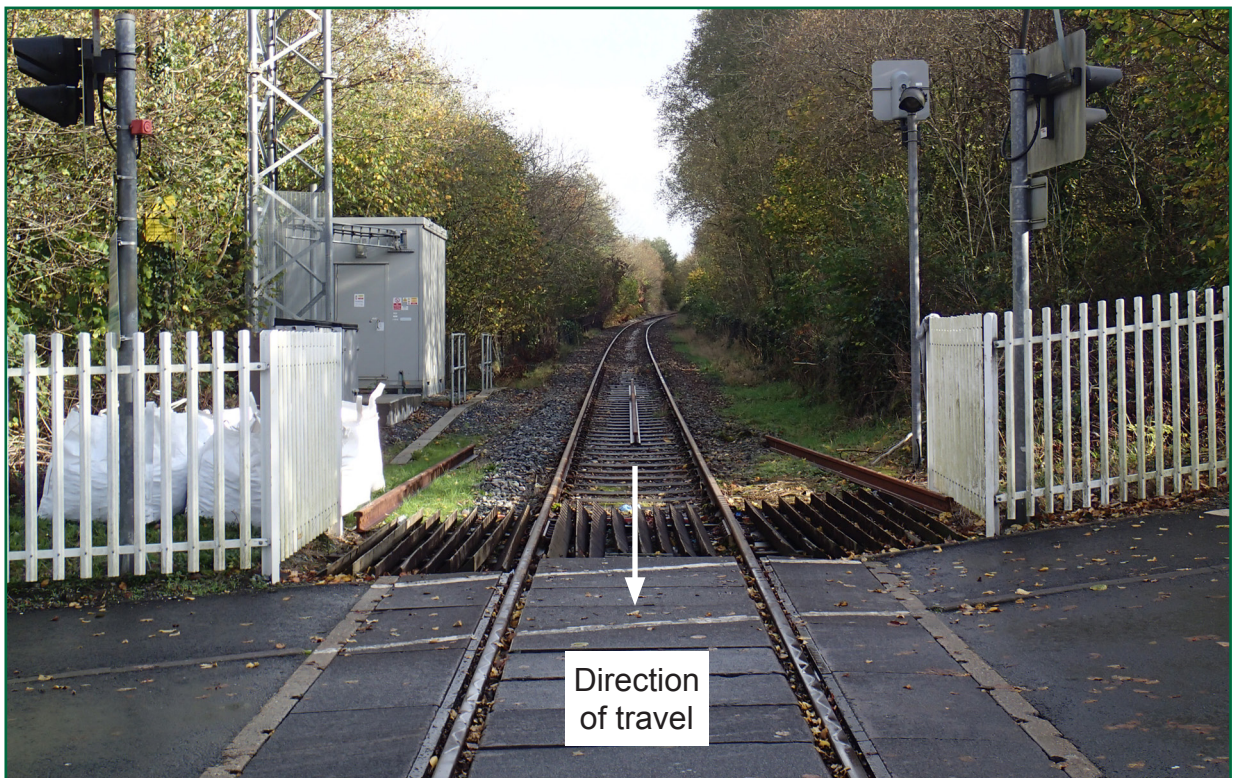

Figure 3: Raven level crossing looking towards GCG

Context

Location

- 6 The Garnant Branch line runs from Pantyffynnon Junction to Gwaun-Cae-Gurwen colliery (figure 4). It is a single line approximately 6.5 miles (10.4 km) long and is used by one freight train per day (although not on every day of the week), making a round trip to and from the colliery.

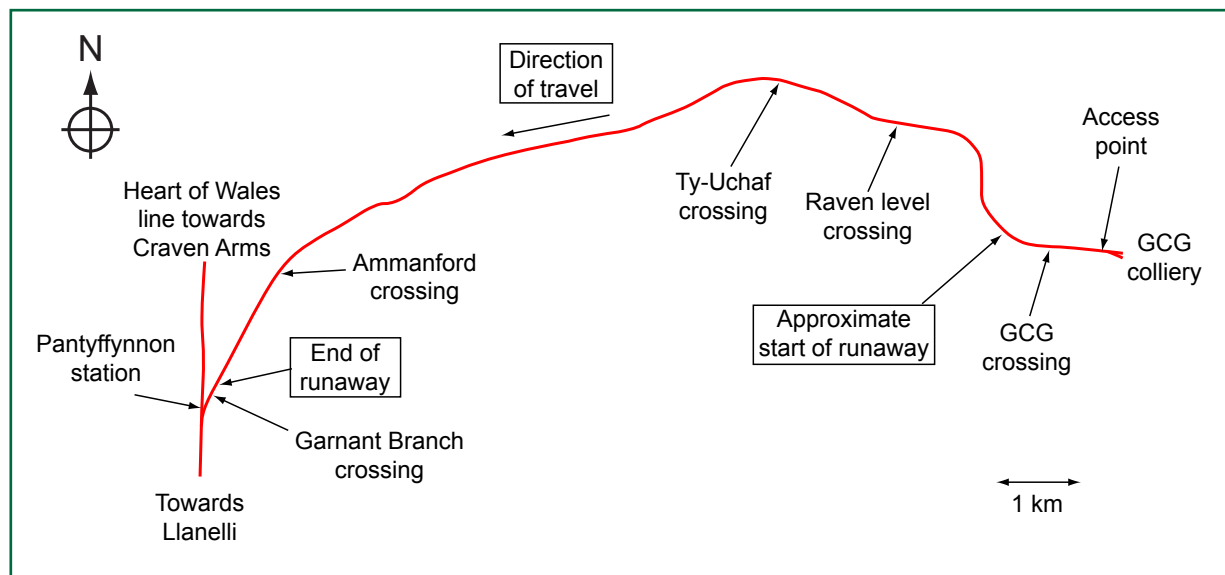

Figure 4: Garnant Branch, showing path of the runaway ironmen on 1 November 2014

- 7 The line descends through a height of 150 metres from GCG to Pantyffynnon, which is equivalent to an average gradient of 1 in 69. The gradient for the 1.3 miles (2.1 km) between GCG and Raven level crossings averages 1 in 40 (figure 5)²; this is the section on which the track workers lost control of the ironmen.

Organisations involved

- 8 Network Rail is the owner and maintainer of the railway infrastructure. It employs the staff who had planned and were carrying out the work at Raven level crossing on the night of 1 November 2014. It also owns the ironmen that were involved in the incident.
- 9 Torrent Trackside is part of Vp plc and maintains items of plant on behalf of Network Rail's maintenance function. It employs the mobile fitter who had serviced the ironmen involved.
- 10 Permaquip Ltd is the designer and manufacturer of the ironmen involved.
- 11 All of the organisations involved freely co-operated with the investigation.

² Note: the RAIB has measured the average gradient over 1.9 km of this section as 1 in 39, rather than the 1 in 40 shown in figure 5.

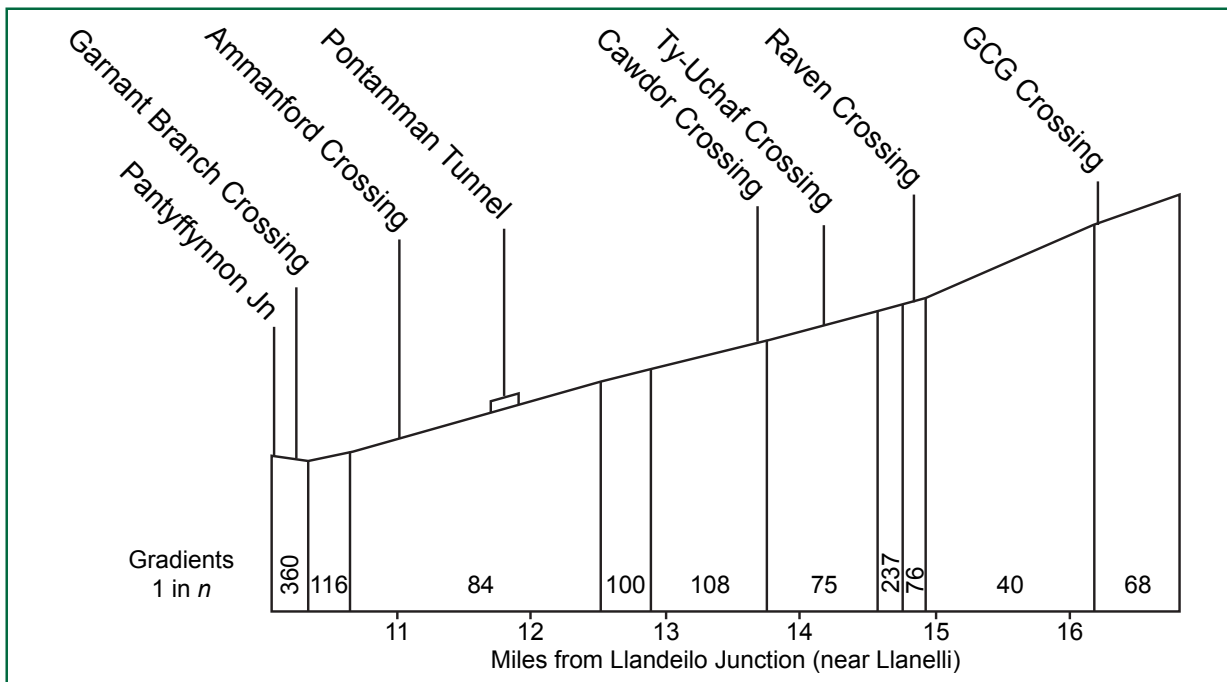

Figure 5: Gradient map of Garnant Branch line (source: Network Rail)

Rail equipment/systems involved

- 12 Ironmen are used for lifting and transporting rails and other track components; generally they are used in pairs, although greater numbers may be used to transport longer sections of rail. The type owned by Network Rail is manufactured by Permaquip and was first introduced in 1996; it was formally approved in 2006 (refer to paragraph 33). The brakes are automatically applied by springs and manually released by the operator by depressing a brake handle (figure 6). The ironman is intended to be pushed; it has no facilities such as a seat or step for operators to ride on.



Figure 6: Use of brake handle to release ironman brakes (courtesy Permaquip)

- 13 The two ironmen that ran away (figure 7 and table 1) were allocated to Network Rail's Haverfordwest track maintenance depot and had been loaned to the Llanelli depot for the work planned to be carried out on the night of 1 November 2014.



Figure 7: The runaway ironmen after the incident

Permaquip serial No.	Network Rail asset No.	Year of supply
000440/29	E0005087	2009
4415/22	202003429	2012

Table 1: Details of the runaway ironmen

- 14 In order to transport the length of rail to Raven level crossing, the two ironmen were positioned approximately 12 metres apart and the 16 metre length of rail was resting on the lower cross-members. The ironmen were oriented such that the brake handles were on the left-hand side in the direction of travel (Permaquip's 'User Guide – Ironman (Standard and LUL)', Ref. MAN/M/O/105 issue 17 states that the brake handles of a pair of ironmen should be on the same side).

Staff involved

- 15 All of the staff from Llanelli depot who were involved in the incident have many years' experience of track maintenance activities. This includes the acting team leader, who was the *controller of site safety* (COSS), the two track workers with the incident rig and the section supervisor, who was responsible for planning the work. The track workers and the COSS had all been assessed as competent to operate ironmen and carry out COSS duties. The section supervisor had been assessed as competent to plan *safe systems of work* and to plan work involving on-track plant; however he did not hold the ironman competence himself.

- 16 The mobile fitter who had maintained the ironmen had more than 10 years' experience of maintaining small items of plant. He had been transferred under TUPE (Transfer of Undertakings (Protection of Employment) Regulations 2006) from AMEC to Speedy Hire, and then to Torrent Trackside when Torrent took over the contract to maintain Network Rail's plant in 2010. He had been sent on a Permaquip ironman training course by AMEC, and had been assessed as competent to maintain ironmen by Torrent Trackside.

External circumstances

- 17 Witnesses reported that there were high winds and heavy rain when the incident occurred. The RAIB has reviewed contemporary records from weather stations located 11.1 km west and 10.7 km east-south-east of Raven level crossing. These show gust speeds of 5.8 – 9.2 m/s (corresponding to force 5 on the Beaufort scale, a 'fresh breeze') and precipitation rates of 1.5 – 3.5 mm/hr (corresponding to the Met Office definition of 'moderate' rain). The temperature was approximately 13°C and it was completely dark. It should be noted that local weather conditions may vary widely in a hilly region such as the Garnant area.
- 18 According to witness evidence, the track workers with the rig decided to hurry in order to get out of the wind and rain (refer to paragraph 23).

The sequence of events

Events preceding the incident

- 19 The work that had been planned by the section supervisor for the night of 1 November 2014 involved the replacement of two 16 metre lengths of rail at Raven level crossing.
- 20 Six track workers from Llanelli track maintenance depot travelled together to the access point at GCG, where the rails that were going to be taken to Raven level crossing had previously been delivered. A seventh member of staff, who was later to be the *engineering supervisor*, had driven separately via Neath to collect a van carrying the ironmen that were to be used.
- 21 The two lengths of rail were planned to be transported using two pairs of ironmen. Gang members worked together to offload the ironmen from the van. They assembled the first pair of ironmen, then picked up and secured the first length of rail. Two of them released the brakes and moved the rig forwards to allow the second pair of ironmen to be assembled and the second rail to be picked up. Witness evidence indicates that the men believed the brakes on the first pair of ironmen were operating correctly, as the rig had been left standing on the gradient without incident while the second rig was prepared.
- 22 One of the track workers did not have wet weather clothing with him and the engineering supervisor had already departed to GCG level crossing in order to operate the crossing (ie close it to road traffic) to allow the two rigs to pass over it. This left five men to bring the two rigs down from the access point to Raven level crossing (a distance of approximately 1.6 miles (2.6 km)).
- 23 Two track workers set off with the first rig; the remaining three followed on behind with the second. The men were walking fast because of the heavy rain and wind (paragraph 18). At some point after passing GCG level crossing, the track workers with the first rig realised they were no longer able to control its speed.
- 24 They were aware that another gang was removing the road panels at Raven level crossing in preparation for replacement of the rails. This meant that gang members would be working in the four foot and would be at risk of injury from the runaway rig. The track workers stated that they each decided to jump onto the rig at the point that they realised they had lost control of it, so that they could warn the gang ahead. They repeatedly tried 'pumping the brakes' and to slow the wheels using their boots, without noticeable effect.

Events during the incident

- 25 When Raven level crossing came into view, the two track workers shouted warnings to the gang working at the crossing and then jumped off the rig.
- 26 The men working in the four foot of the crossing were from Network Rail's Off-track maintenance section in Swansea. They were using temporary lighting powered by a generator, and a self-propelled machine was being used to lift the road panels out. One of the gang heard the track workers on the rig shouting, looked up and shouted at the other members of the gang to get clear. The gang moved clear with an estimated two seconds to spare before the rig passed over the crossing.

- 27 One of the track workers received cuts and bruising to his face when he jumped off the rig, and was taken to hospital.

Events following the incident

- 28 The section supervisor, who was acting as the *person in charge of the possession* (PICOP), was standing nearby, talking to the engineering supervisor, when he noticed the rig run over the crossing. The section supervisor immediately set off in his van to try and stop any road traffic at the other crossings along the branch line.
- 29 The next level crossing after Raven (Ty-Uchaf) is an automatic open crossing locally monitored (AOCL). When the section supervisor reached this crossing, he saw that the lights were still operating although the rig had passed.
- 30 He then drove straight to Ammanford, where the level crossing is on an 'A' road, close to a supermarket in the town centre. Ammanford crossing is a train man operated (TMO) crossing and the section supervisor was concerned about the rig running over the crossing while it was still open to road traffic. He observed the rig pass over the crossing but it was travelling too fast for him to attempt to stop it. There was no road traffic close to the crossing at the time.
- 31 The section supervisor was subsequently able to stop the rig just short of the Garnant Branch crossing, about 300 metres from the junction with the main line at Pantyffynnon. He then chained the rig to the track to prevent any further runaway.
- 32 Meanwhile, the three men with the second rig were unaware of what had happened. They also nearly lost control of their rig on the way down to Raven level crossing; it took them an estimated quarter of a mile to stop.

Key facts and analysis

Background information

Approval of the ironman for use on Network Rail infrastructure

- 33 Network Rail has a *product acceptance* process by which it approves equipment for use on its infrastructure. A product acceptance certificate for the Permaquip ironman was issued by the certification body, AEA Technology Rail, on 7 April 2006. At the time, product acceptance was carried out in accordance with Network Rail's company standard 'Product Acceptance', Ref. NR/CS/ACC/029 issue 5; this required Network Rail to define the acceptance criteria for a new or modified product. The ironman acceptance certificate stated that the engineering design of the equipment had been scrutinised in accordance with GM/RT1310 (issue 2) and that it conformed to the appropriate mandatory requirements.
- 34 The *Railway Group Standard* referred to by the product acceptance certificate, 'Design Requirements and Acceptance of Portable/Transportable Infrastructure Plant and Work Equipment', Ref. GM/RT1310 issue 2, December 1998, included the following requirements for braking systems: 'All Equipment fitted with rail wheels and which is capable of running away shall be fitted with a brake, which shall be capable of stopping and holding the item of Equipment, complete with any load it is designed to carry/use, on a gradient of 1 in 30.'
- 35 An additional document that is relevant to the acceptance of ironmen for use on Network Rail infrastructure is the 'Code of Practice for Rail Mounted Manually Propelled Equipment', published by the Rail Safety & Standards Board (now known as RSSB) on behalf of the M&E Engineers Networking Group, Ref. CoP0018. Issue 1[a] of CoP0018 was dated March 2006 and stated that it applied 'to all rail mounted manually propelled equipment used on Network Rail infrastructure'. It also stated that such equipment must meet the stopping distances given in 'Railway applications – Track – Safety requirements for portable machines and trolleys for construction and maintenance', Ref. BS EN 13977:2005; these were specified from 6 km/h³.
- 36 A description of the ironman braking system is given at appendix G. As discussed at paragraph G2, the stopping distance is dependent on the *brake torque*. This relationship is non-linear, such that a reduction in brake torque below the specified minimum will result in a disproportionate increase in the stopping distance. Consequently, for acceptance testing to be representative for equipment with the minimum brake torque, the brake torque should be adjusted to this minimum level prior to the testing – alternatively the results may be factored by an appropriate amount. This is discussed further at paragraph 76.

³ The current version of CoP0018, issue 5, now requires tests to be carried out from both 5 km/h and 10 km/h.

- 37 Neither Network Rail nor Permaquip has been able to provide the RAIB with a copy of the brake test results that supported the product acceptance certificate issued on 7 April 2006. However, records of testing carried out on 18 April 2006 do exist; these show that the ironman complied with the stopping distances mandated by BS EN 13977:2005 for wet and dry conditions, both 'walking' and 'running' (figure 8)⁴. The results also record that the average brake torque for the ironman being tested exceeded the minimum brake torque that was specified at the time (30 Nm, refer to paragraph 69) by 21%.

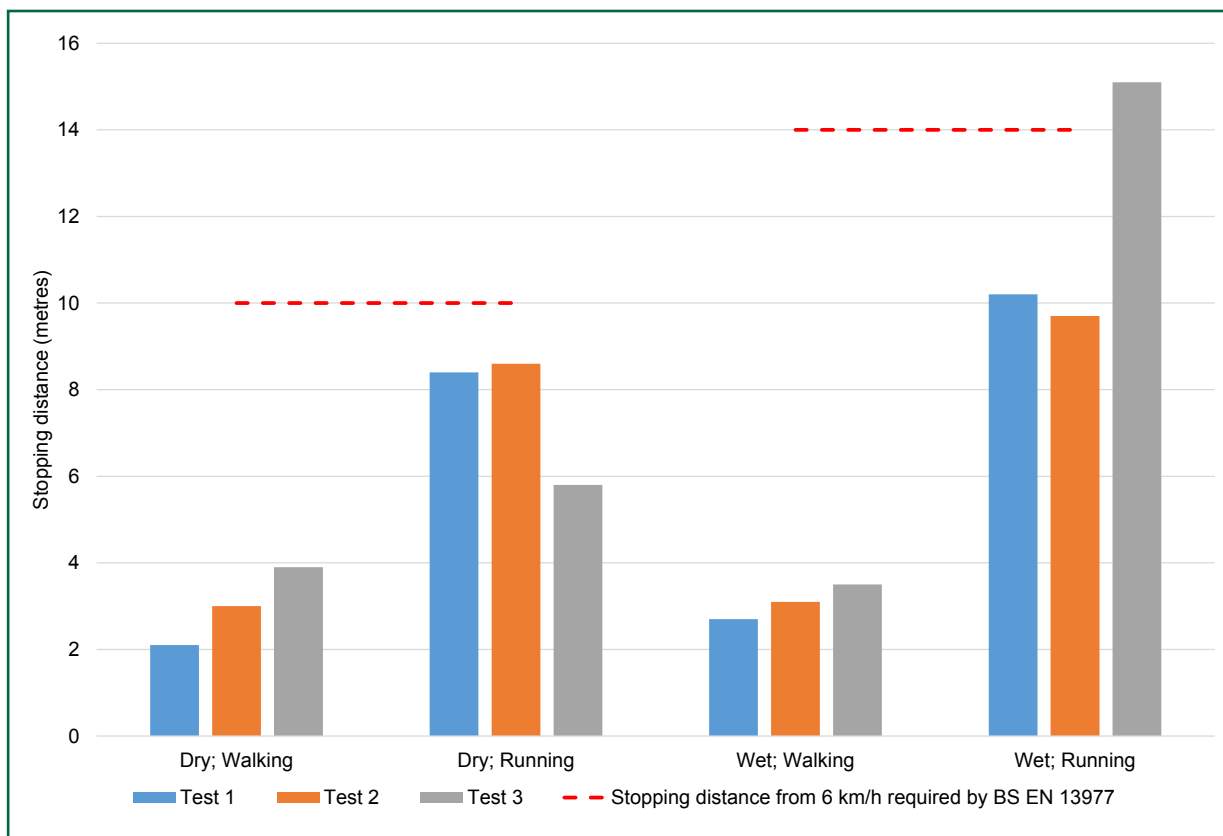

Figure 8: Ironmen stopping distance tests 18 April 2006

- 38 GM/RT1310 was superseded in June 2009 by 'Rail Industry Standard for Portable and Transportable Plant Used for Infrastructure Work', Ref. RIS-1701-PLT issue 1, October 2008. An associated product acceptance certificate for the Permaquip ironman was subsequently issued on 8 February 2010; this stated that the documentation that had been assessed as part of the application for product acceptance was Permaquip's user guide, Ref. MAN/M/O/105 issue 15 and Rail Industry Standards Refs. RIS-1700/1701-PLT issue 1⁵.
- 39 Neither Network Rail nor Permaquip has been able to provide the RAIB with a copy of the brake test results that supported the product acceptance certificate issued on 8 February 2010. It is reasonable to assume that the results complied with the requirements of RIS-1701-PLT issue 1. These included meeting the stopping distances shown in table 2 in maximum laden and unladen conditions.

⁴ The test results did not relate the terms 'walking' and 'running' to any specific speeds.

⁵ The versions of these two documents that were current when the certificate was issued were 'Rail Industry Standard for Safe Use of Plant for Infrastructure Work', Ref. RIS-1700-PLT issue 2, and RIS-1701-PLT issue 1.

Gradient	Dry rail stopping distance (m)	Wet rail stopping distance (m)
Level	6	10
1 in 27	10	14

Table 2: Stopping distances from 3 mph (5 km/h) as required by RIS-1701-PLT issue 1

- 40 RIS-1701-PLT issue 1 stated that the maximum speed of manually propelled plant was 3 mph (5 km/h), and that this should be controlled by staff discipline. This was reflected in RIS-1700-PLT, which included the general requirement that in no circumstances should such plant be allowed to travel faster than 3 mph.
- 41 There is no limitation on the intended use of the brake fitted to manually propelled plant in any of the relevant standards, codes of practice or manufacturer's instructions. In particular, there is no guidance on whether it should be used only as an emergency brake, in addition to its use as a parking brake, or whether it may also be suitable for use to control the speed of a trolley on a gradient.

Identification of the immediate cause

42 The track workers were unable to control the speed of the rig on the descent towards Raven level crossing.

- 43 Although the brake handles had been released, in order to apply the brakes, the track workers were unable to prevent the rig from accelerating.

Identification of causal factors

- 44 The incident occurred due to a combination of:
- the planning of the work (paragraphs 45 to 51);
 - the control of the work (paragraphs 52 to 58);
 - the speed of the rig (paragraphs 59 to 65); and
 - the performance of the ironmen's brakes (paragraphs 66 to 94).
- Each of these factors is now considered in turn.

The planning of the work

45 The task planning for the work at the level crossing had not adequately mitigated the risk from use of the ironmen on the gradient.

- 46 The arrangements for planning work on or near the line are set out in Network Rail's company standard 'Safety of people working on or near the line', Ref. NR/L2/OHS/019 issue 8, September 2010. A responsible manager decides how work is to be prioritised, planned and delivered, and a planner prepares a safe system of work (SSOW) pack; this is accepted or rejected by the responsible manager. The SSOW pack is then issued to the COSS, who retains ultimate responsibility for safety on site. Among the documents that are normally used in the preparation of the SSOW pack is the *hazard directory*.

- 47 The section supervisor had been the responsible manager for the planning of the work that was to be carried out at Raven level crossing on the night of 1 November 2014 (paragraph 19); he had also allocated the resources for the work. The plan provided for seven members of staff to bring the two pairs of ironmen carrying the two lengths of rail down from the access point at GCG to the site of work at Raven level crossing.
- 48 The rails could not be delivered directly to the crossing because there was no room to offload them from a road trailer and to turn them parallel to the railway. The section supervisor considered having the rails delivered beforehand either to Pantyffynnon or to GCG. It would have been necessary to have used two road rail vehicles and trailers to bring the rails up from Pantyffynnon. Llanelli track maintenance depot allocates such machines to a specified number of jobs at the beginning of each financial year, and the work at Raven level crossing had arisen subsequently. This meant machines would have to have been procured on a spot hire basis, which is reported to be significantly more expensive. The section supervisor therefore decided to have the rails delivered to GCG and then transported down the gradient to Raven level crossing using ironmen. The rail that was to be recovered during the work would be cut up so that it could be collected using the depot's road vehicles.
- 49 Witness evidence indicates that the section supervisor was aware of the gradient between GCG and Raven level crossings when he planned the work. Although he did not consider that the gradient presented a particular risk, he decided that the two lengths of rail should be transported separately using two pairs of ironmen (the load could theoretically have been carried on one pair of ironmen). The section supervisor had not been trained in the use of ironmen and did not hold the associated competence (PTMP 07.01). He was unaware that the *Rule Book*, Network Rail's Plant Manual and risk control sheet SP07 (paragraph 60) all required there to be at least four people with each rig (and thus eight were required for the two rigs). Requirements that are implicitly relevant to the use of ironmen are cross-referenced between at least four different modules of the Plant Manual (P501, P502, P503 and P514).
- 50 'Duties of the COSS and person in charge when using a hand trolley', Ref. GE/RT8000/HB10 issue 2, June 2014 (Handbook 10 of the Rule Book) states that a trolley should not be used on a gradient steeper than 1 in 50 unless this had been specially authorised in local instructions; no such instruction exists for the Garnant Branch⁶. The hazard directory for the section of line between GCG and Raven level crossings includes the following entry: 'The gradient at this location is greater than 1 in 50. This must be considered in the planning and use of on track plant and hand trolleys.' This information was not included in the SSOW pack; nor was the risk of a runaway identified. Witness evidence indicates that the software used to generate SSOW packs automatically includes some entries from the hazard directory, although this does not include gradient information.
- 51 The section supervisor was aware of the 1 in 50 limit, but he was also aware of previous work in which trolleys had been used without incident on this section of line. He did not consider specifically whether the 1 in 50 limit was relevant to the work to be carried out on 1 November 2014.

⁶ Network Rail has been unable to identify any such local instructions for any of its infrastructure.

The control of the work

52 The responsibilities of the ‘person in charge of the trolley’ were not carried out.

- 53 Handbook 10 of the Rule Book defines the responsibilities of the person in charge of the trolley; there should have been one such person for each of the four ironmen that had been assembled at GCG. These responsibilities were not clearly allocated to individuals on site and the need for this to be done is not included either in Network Rail’s training for the ‘ironman’ and ‘safe use of trolley’ competences (PTMP 07.01 and PTMP 16) or in its Plant Manual. The responsibilities of the person in charge of the trolley included making sure that:
- ‘the trolley’s braking system has been tested and is in good order’;
 - ‘the trolley is not placed on or used on a line which has a gradient greater than 1 in 50, unless specially authorised in local instructions’;
 - ‘the trolley has at least two people with it when moving and one of them must be in charge of the brake’; and
 - ‘a red flag or red light is displayed on the trolley – the flag or light must be visible in both directions’.

These responsibilities were not carried out for the ironmen at GCG.

- 54 Handbook 10 of the Rule Book does not detail how to test the brakes. The pre-use checks of a trolley’s braking system required by Network Rail include making an attempt to turn the braked wheels using one hand; the wheels should resist movement (refer to paragraph 102). Witness evidence indicates that this check was not carried out at GCG. Gang members believed that the brakes on the ironmen were functioning because the first pair of ironmen stood on the gradient without moving after they had been loaded with the length of rail.
- 55 Although Handbook 10 of the Rule Book includes a restriction on the use of a trolley on a gradient steeper than 1 in 50, this restriction is not explicit in Network Rail’s training material for the use of ironmen. Instead, Network Rail trainer’s plan ‘Ironman’, Ref. NR/C&TM/PTMP07.01 issue 1.2, refers to a maximum gradient of 1 in 27 (as stated in Permaquip’s user guide MAN/M/O/105); it is therefore possible that the track workers were unaware of the restriction. Witness evidence indicates that the gang members were aware that the section of line below GCG was the steepest gradient covered by Llanelli track maintenance depot, however the SSOW pack did not include the information that the gradient was steeper than 1 in 50 (paragraph 50) and the gradient restriction was not applied.

- 56 The track workers were aware of the requirement for there to be at least two people with each ironman, but they believed this related only to pushing equipment on rising gradients (paragraph 62). This perception was probably reinforced by the training they had received. As well as the statement in Module 514 of the Plant Manual (paragraph 60), trainer's plan NR/C&TM/PTMP07.01 includes the following (italics added by RAIB): 'Ironmen shall not be moved above a maximum speed of walking pace ie 3 mph or 5 km/h. Where the item of manually propelled equipment (including its intended load where applicable) is to be used on a gradient, adequate manpower shall be provided *to safely push the load uphill*'. A similar emphasis on rising gradients exists in trainer's plan 'Safe Use of Trolley Equipment Module', Ref. NR/L2/CTM/PTMP16 issue 2.1. The training material does not specifically mention the need for adequate manpower to control the speed of ironmen or trolleys on falling gradients.
- 57 Although seven members of staff had been allocated to the work, only five were available on the night as one person was sick and one did not have his wet weather clothing (paragraph 22). Witnesses report that the men thought that this was sufficient, and that none of them considered raising a concern. The COSS did not challenge the number of staff allocated to transporting the rails even though this was fewer than the rules required; this was probably because he shared the perception that the numbers of people specified were associated with pushing loaded trolleys and ironmen on rising gradients.
- 58 Ironmen are equipped with brackets to hold battery operated red lights; these are normally retained by allen bolts. Neither of the runaway ironmen was equipped with lights on the night of 1 November 2014 (refer to paragraph 104).

The speed of the rig

59 The speed of the rig was not sufficiently controlled to prevent a runaway.

- 60 RIS-1700-PLT notes that brakes are generally only designed to cope with walking speeds (ie 3 mph (5 km/h), paragraph 40), and that there is 'a very significant risk that the brakes of a manually propelled item of railborne plant could not prevent the plant running away if used at higher than walking speeds on gradients'. The pair of ironmen was almost certainly travelling faster than 3 mph (5 km/h) at the point that the track workers realised that they had lost control of them (paragraph 23).
- 61 A number of documents require that there should have been a minimum of four people with each pair of ironmen:
- a. Handbook 10 of the Rule Book requires at least two people to be with a trolley (the definition includes all manually propelled equipment mounted on rail wheels or runners) when it is moving (see paragraph 53). Consequently there should have been at least two people with each ironman (four with each of the two rigs).
 - b. 'Hand-controlled trolleys', Ref. NR/PLANT/0200/module P514 issue 1, March 2013: Module P514 of Network Rail's Infrastructure Plant Manual states that adequate manpower should be used when 'pushing' a trolley on a gradient⁷. Its guidance indicates that four people were required with the rig, which had an estimated gross weight of 1212 kg and was being used on a 1 in 40 gradient.

⁷ This document does not explicitly mention operation of trolleys on falling gradients.

- c. 'Use of Iron Men', Ref. NR/L3 /MTC/RCS0216/SP07 issue 2: Network Rail's risk control sheet SP07 states that a minimum of two operators should be allocated to each ironman whilst moving rails on track.
- 62 Witness evidence indicates that there was a general belief among the staff at Llanelli track maintenance depot that the reason for there being a minimum number of people specified was to enable loaded ironmen to be pushed, particularly on rising gradients (see paragraph 55). The perception was that the brakes were sufficient to control the speed of loaded ironmen on falling gradients, and that the role of the operators did not include providing any braking effort themselves. The RAIB considers that, without making use of the brakes, four people would have been better able to prevent the rig from reaching a speed at which it would have run away. The three men with the second rig were just able to control its speed, although they only managed to stop it when the gradient reduced approximately 280 metres before Raven level crossing.
- 63 The two track workers with the incident rig were walking fast as a result of the inclement weather (paragraph 23). The gradient increases after passing over GCG level crossing and they soon realised that the rig was accelerating and that they could not slow it down.
- 64 The RAIB is aware of a suggestion made by individuals within the industry that the two track workers were riding on the rig before they lost control of it. If this had been so, it is probable that they would have been less aware of the speed of the rig and less likely to realise that they were on the point of losing control until it was too late. Riding on the ironmen would have contravened Handbook 10 of the Rule Book. The track workers are adamant that they did not start to ride on the ironmen until the rig had started to run away and the RAIB has found no evidence that they did.
- 65 Conversely, there is evidence that the two track workers with the incident rig were not predisposed to riding on it. A recording from a closed circuit television (CCTV) camera outside a supermarket at GCG indicates that they did not ride on the rig even when they had an incentive to do so. The recording shows the two pairs of ironmen passing over GCG level crossing shortly before the runaway occurred. To avoid walking on the cattle-cum-trespass guards at the crossing, which are designed to be hard to walk on, it would have been necessary either to walk along the rails (which were slippery and difficult to balance on) or to ride on the rig over the crossing. The CCTV recording shows that both of the men with the incident rig opted to walk on the rails rather than climb onto it.

The performance of the ironmen's brakes

66 The brakes on the ironmen were unable to control the speed of the rig.

- 67 The pair of ironmen that ran away on 1 November 2014 had a payload of 0.9 tonnes (30% of the combined safe working load of two ironmen) and ran away on a gradient that averaged 1 in 39 (footnote to paragraph 7), which is well within the maximum design gradient of 1 in 27 declared by Permaquip. Witness evidence indicates that the track workers with the ironmen had not previously experienced any difficulties with the brakes on ironmen. It is therefore necessary to understand why the brakes did not prevent the rig from running away.

68 The performance of the brakes was probably inadequate at the start of the shift; this is considered at paragraphs 69 to 89. In addition, the performance of the brakes almost certainly deteriorated as they were continually used in an attempt to control the speed of the ironmen; this is considered at paragraphs 90 to 94.

The brake springs fitted to the leading ironman

69 In April 2009, Permaquip (then part of Harsco Track Technologies) issued a memo addressed to 'to whom it may concern' outlining some modifications to the design of ironmen that it stated had been mandated by Network Rail; these included an increase in the required brake torque to 40 Nm (this was an increase of 33% over the previous minimum of 30 Nm). The memo stated that any existing ironmen should be modified by 1st June 2009.

70 As noted at paragraph G2, appendix G, one of the factors affecting brake torque is the *spring rate* of the brake springs. In its memo, Permaquip advised that a higher force brake spring was available (this had a different part number to the existing spring and the spring rate was 79% higher). At around this time, Permaquip changed the standard spring without changing its part number; this delivered an increase in spring rate of 37%. The RAIB has seen no evidence that this change in spring rate was communicated to Permaquip's customers or their maintainers. Permaquip advises that the change was the result of changing supplier to improve quality, performance and value for money.

71 Permaquip's 2009 memo also suggested that it might be possible to increase the brake torque by inserting shims behind the existing brake spring as an alternative to changing the spring. The insertion of a shim pre-loads the spring by compressing it, thereby increasing the brake torque. Permaquip currently fits shims to approximately 10% of new ironmen when it encounters difficulties in achieving the required brake torque of 40 Nm. It has advised the RAIB that the use of shims to increase the brake force is its 'preferred and approved method to adjust the force, ensuring the minimum brake torque is achieved'.

72 Torrent Trackside has advised the RAIB that it has no record of having been notified about the use of shims to increase brake torque before the runaway occurred on 1 November 2014. It updated its maintenance schedule in October 2009 to reflect the increase in required brake torque to 40 Nm; this revised torque had been included in a reissue of Permaquip's user guide MAN/M/O/105 although the possible use of shims and the increased spring rate had not.

73 The RAIB tested the forces delivered by the brake springs fitted to the two runaway ironmen and compared them with the specification of the two types of standard spring as well as with four new springs supplied by Permaquip. The springs fitted to the leading ironman (No. E0005087) were to the pre-2009 specification, while those from the trailing ironman (No. 202003429) were to the post-2009 one. The springs fitted to the leading ironman delivered an average of 73% of the force of the springs fitted to the trailing one. All of the springs tested delivered higher forces than the applicable specification.

- 74 Ironman No. E0005087 was tested on behalf of the RAIB with slack brake cables (so that the cables did not reduce the brake force, see appendix G, paragraph G5), new brake pads and the original brake springs, without shims. This found that it was practically impossible to achieve the required minimum average torque of 40 Nm. An average torque of 39.6 Nm was achieved only after both wheels and pads had been roughened with emery paper (figure 9). Such roughening is not a normal maintenance practice and would probably not be effective in maintaining the brake torque once the aluminium wheels have rolled a short distance along rails and once the pads have been used to stop an ironman a few times.
- 75 At the time of Permaquip's memo of 15 April 2009 (paragraph 69), Speedy Hire was contracted to maintain Network Rail's items of small plant. Although Speedy Hire has no record of having received the memo, it issued a technical bulletin to its mobile fitters on 1 January 2010. This explained that the required brake torque had been increased to 40 Nm and that Permaquip was now supplying a 'heavier duty version' brake spring; new brake springs should be fitted if there were difficulties in achieving the specified torque. No record appears to exist as to why Network Rail did not instigate replacement of the brake springs on its ironman fleet, which included the leading ironman involved in the runaway on 1 November 2014.

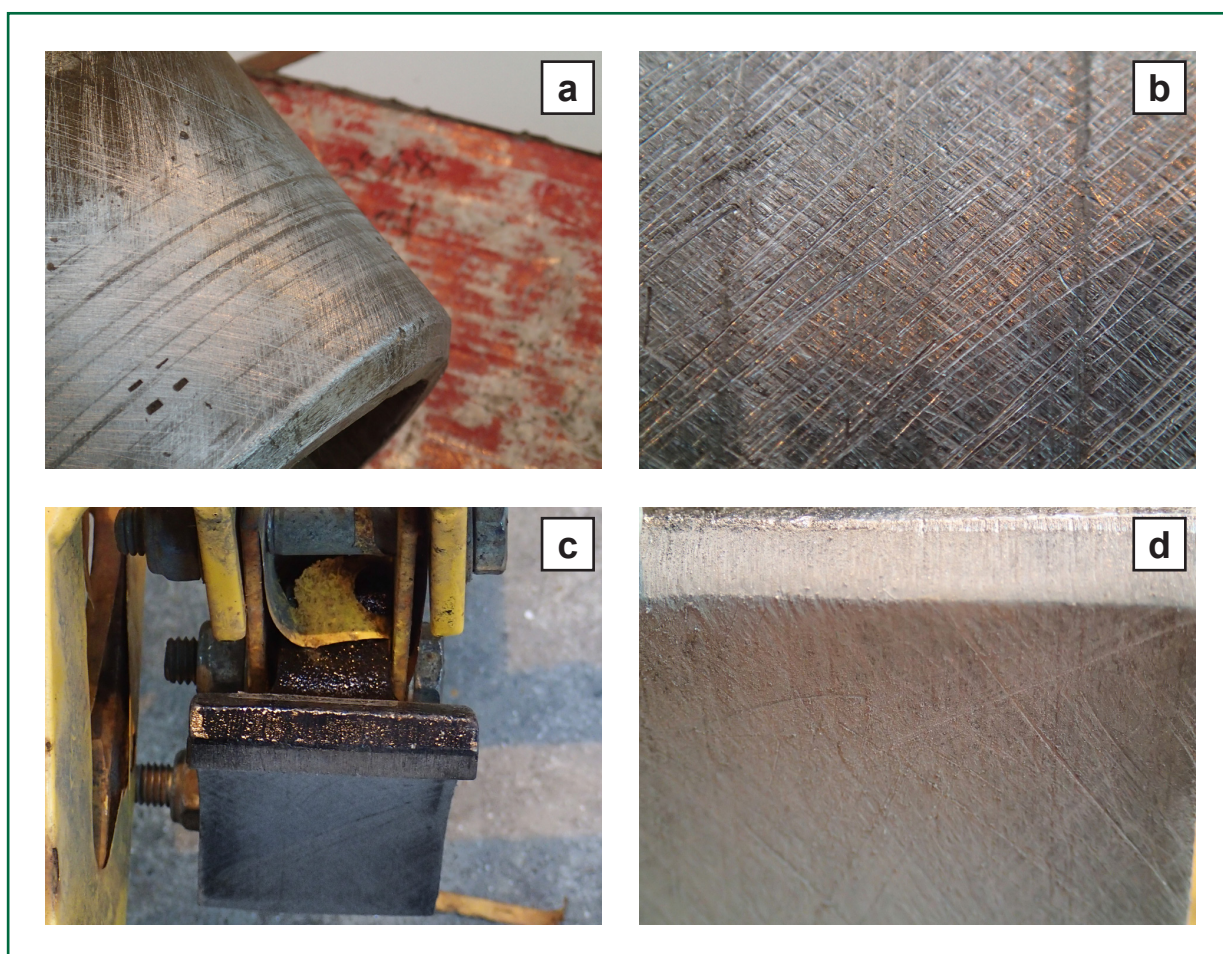

Figure 9: General view (a) and close-up (b) of wheel surface, and general view (c) and close-up (d) of brake pad surface, showing roughening with emery paper

76 The results of the brake testing carried out on 18 April 2006 were not representative of the performance of brakes which would have just met the minimum torque figure, as the static torque exceeded the minimum by 21% (paragraph 37). It is not known by how much the static torque exceeded the revised minimum when further brake tests were carried out to support the product acceptance certificate that was issued on 8 February 2010 (paragraph 39). The RAIB has seen no evidence that the relationship between stopping distance and brake torque was taken into account as part of the product acceptance process; this relationship is non-linear (paragraph G2, appendix G). This means that the brake testing that was carried out in support of product acceptance may not have been adequate to ensure compliance with the required stopping distances.

The adjustment of the brakes

- 77 Torrent Trackside's maintenance schedule 'Lightweight Iron Man', Ref. MS088 issue 10, March 2012, does not mention the requirement in Permaquip's user guide MAN/M/O/105 that the brake cables should be slack when the handle is released (see appendix G). It has advised the RAIB that this is because it could not be 'measurably defined'. Although Torrent Trackside's mobile fitters are issued with tablet computers enabling them to refer to MAN/M/O/105, MS088 (and the associated maintenance sheet 'Lightweight Iron Man', Ref. MS088-01 issue 1, March 2012) is the primary document used during maintenance activities.
- 78 The runaway ironmen were tested on behalf of the RAIB so as to replicate their condition when they had last been maintained before the runaway, on 5 September 2014; at this time they had been fitted with new brake pads. The testing involved taking a series of torque measurements for both of the braked wheels of each ironman for various lengths of the brake adjuster⁸. Each data point represents the average of 32 individual torque measurements; these were taken twice for each quadrant of each wheel in both directions.
- 79 The results for testing of the leading ironman (No. E0005087) are shown at figure 10. These show that there is a region of constant brake torque while there is still slack in the cables; this was 26 Nm without roughening of the wheels and pads (paragraph 74). This region is followed by a linear reduction in torque as the length of the adjuster is reduced further, culminating in an abrupt reduction when the pad is no longer held in contact with the wheel. The length of the adjuster, as found after the runaway, indicates that the brakes had previously been adjusted so that there was minimal slack present with new brake pads. This is consistent with witness evidence that Torrent Trackside's mobile fitter would normally turn the adjuster by hand to take the slack out of the brake cable before tightening the locknuts. A total loss of brake force occurred after a reduction in adjuster length that was equivalent to 0.5 mm of brake pad wear.

⁸ These measurements were made and recorded by two people working together, see paragraph 85. The adjuster length was measured between the insides of the turnbuckle pins (see appendix G for a description of the Ironman braking system).

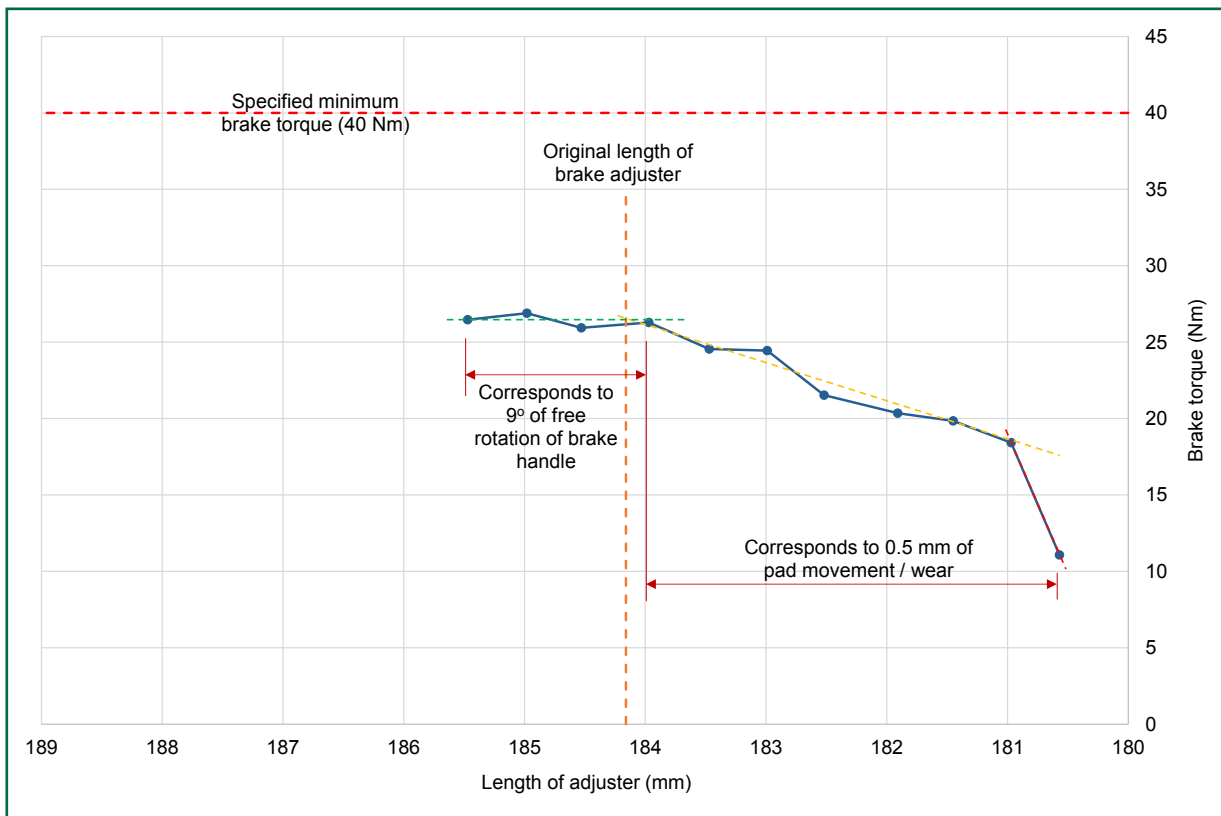

Figure 10: Brake torque measurements; ironman No. E0005087

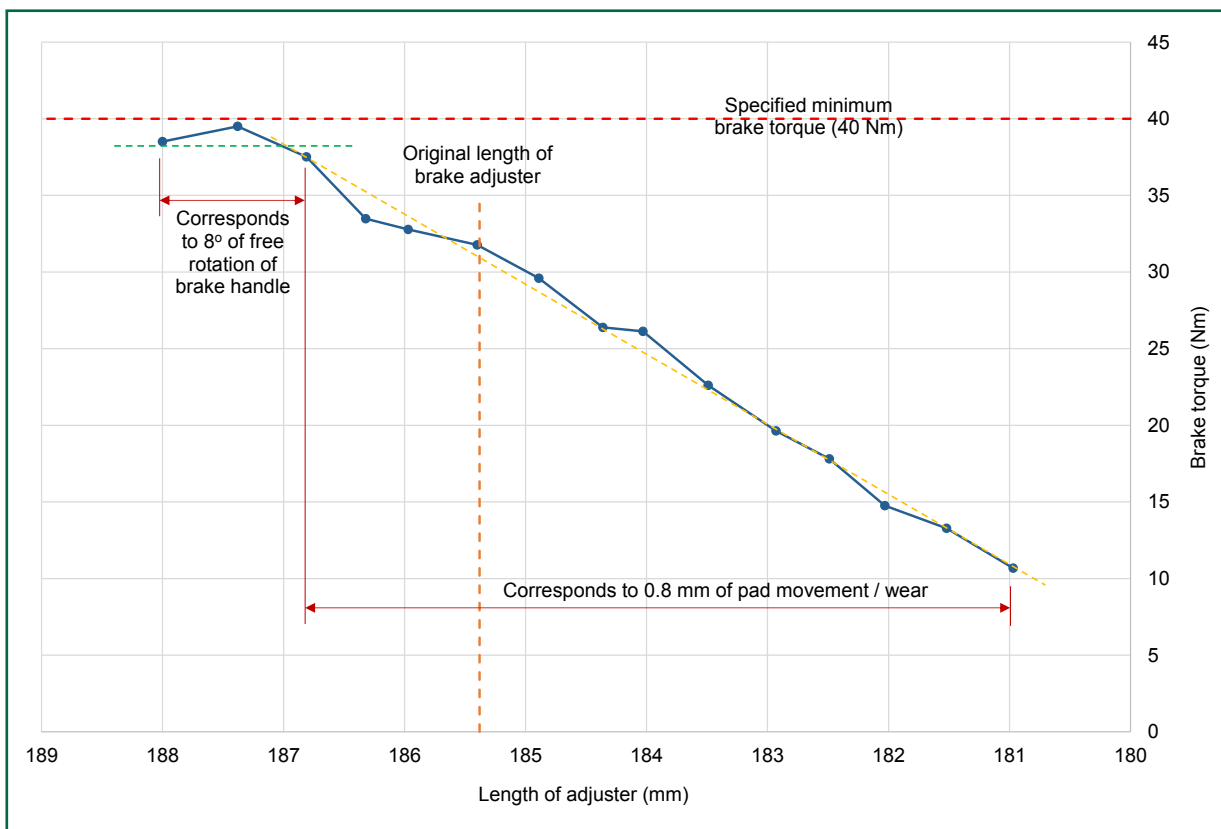

Figure 11: Brake torque measurements; ironman No. 202003429

80 The results for testing of the trailing ironman (No. 202003429) are shown at figure 11; this ironman was fitted with the later type of springs that had a spring rate 37% higher than those fitted to the leading ironman (paragraph 70). The results show a region of constant torque while the cables are slack; this is slightly lower than the specified minimum of 40 Nm. There is a linear reduction in torque as the adjuster is progressively tightened, up to the point that the measurements became unreliably small. No sudden loss of brake force was observed; this may have been because the bottom pulley of the vertical brake cable was progressively collapsing with increasing cable tension during the testing (figure 12). The average brake torque with new brake pads, and with the brake adjuster at the length at which it was found after the runaway, was approximately 32 Nm.

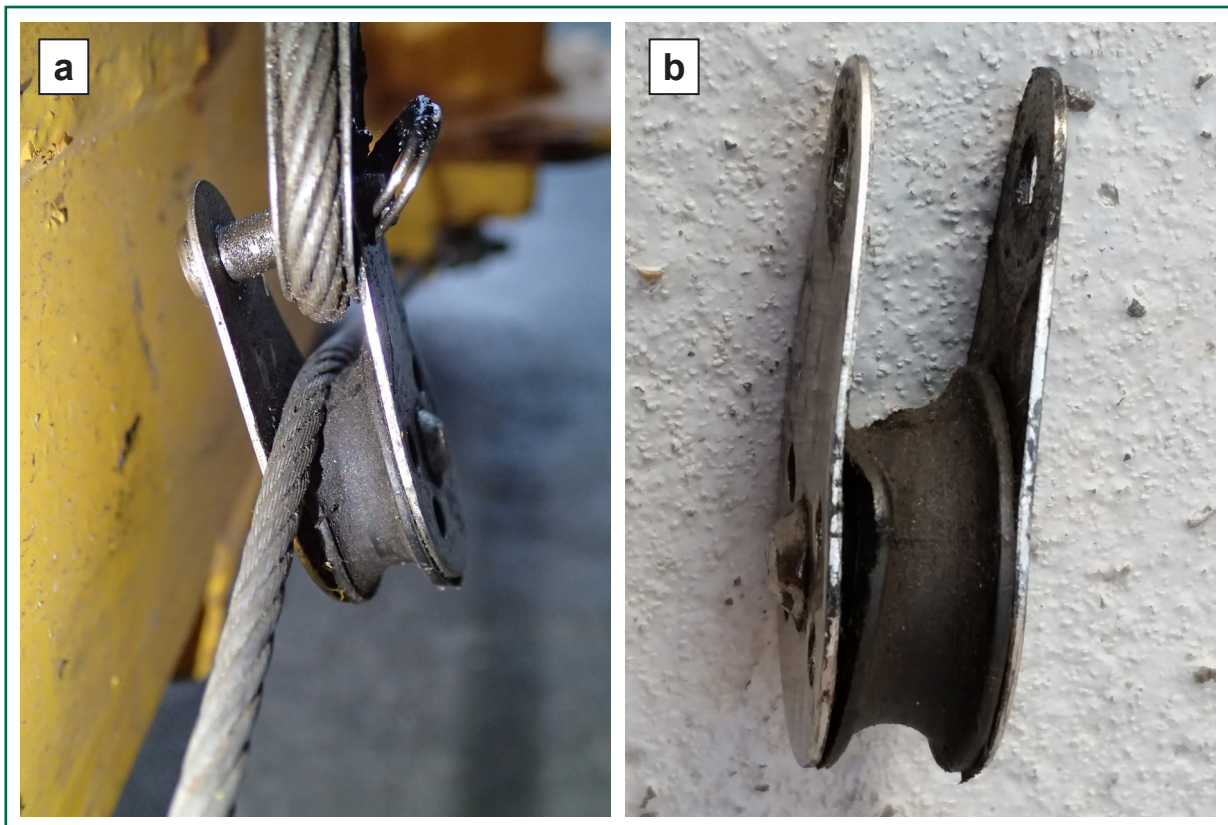

Figure 12: Bottom pulley from ironman 202003429 (a) after the runaway, (b) after testing

81 Assuming that the brakes on the ironmen had not been adjusted after servicing (refer to paragraph 95), and ignoring the effect of any cleaning of the wheels by Torrent Trackside's mobile fitter (refer to paragraph 87), the average brake torque for the two runaway ironmen was probably approximately 29 Nm after they had been serviced on 5 September 2014. It is not possible to estimate the amount of brake pad wear before the work on 1 November 2014, although Network Rail has advised that the ironmen had been used on two occasions between these dates:

- a. 18/19 October 2014: two trips of 400 metres on a gradient of 1 in 75, carrying a 60 foot and a 40 foot length of rail (approximate weights 1,030 and 690 kg) respectively.
- b. 25/26 October 2014: two trips of 800 metres on a gradient of 1 in 858, carrying a 60 foot length of rail (approximate weight 1,030 kg) on each trip.

The testing of the brakes during maintenance

- 82 Permaquip's user guide MAN/M/O/105 states that the maintenance and testing of the brakes are covered by CoP0018 (see appendix E). This describes how the brake torque should be measured at intervals of no greater than three months and refers back to the manufacturer's instructions, where the minimum average torque figure of 40 Nm is stated. These requirements are included in Torrent Trackside's maintenance sheet MS088-01.
- 83 Witness evidence indicates that the Torrent Trackside fitter tended to focus on achieving the minimum average torque figure, even if this involved using undocumented practices such as cleaning/roughening wheels and pads with wire wool or sandpaper (see paragraph 87). Such practices may be effective in initially increasing the brake torque, but this may mask an underlying deficiency in the braking system such as springs that deliver insufficient force. Although testing has not been carried out to confirm this, the RAIB considers that roughening of wheels and pads is unlikely to provide a sustained increase in brake torque (paragraph 74).
- 84 It is not possible to carry out the CoP0018 brake test as defined at appendix E, on an ironman. The definition states that the objective is to ascertain a 'dynamic' figure of the torque required to turn the wheel with the brake applied, and that this should be obtained by taking a torque reading while the wheel is turning. There are two difficulties with the test: (1) there is insufficient room to continue turning the wheel while taking a torque measurement as the test tool comes into contact with the frame, and (2) most torque wrenches operate on a 'peak hold' basis. This means that the reading obtained is actually the torque necessary to overcome the static friction; it is not possible to convert static torque to dynamic torque as there are too many unknowns.
- 85 A further practical difficulty with the CoP0018 brake test is the requirement to take eight torque measurements for each wheel. For an individual working alone, this either means interrupting the work flow to record the reading after each measurement or else making a mental note of the readings and recording them after completion. Statistical analysis reveals a significant difference between the variances of the measurements recorded by the individuals working alone and those who were being observed during the investigation. Forty-eight sets of measurements made during the investigation were compared with thirty-two sets of measurements made by Torrent Trackside mobile fitters (not including the fitter who had serviced the runaway ironmen on 5 September 2014). The narrow range of variation in the measurements recorded by the Torrent Trackside fitters is consistent with recollection after completing each set of measurements rather than contemporaneous recording.

- 86 The torque figures recorded when the ironmen were serviced at Haverfordwest track maintenance depot on 5 September 2014 (appendix F) were not credible. Witness evidence indicates that the mobile fitter who serviced the ironmen recorded the results in lbft. On this basis, the average torques recorded were 110 and 115 Nm for ironmen nos. E0005087 and 202003429 respectively. These figures compare with those of 26 and 32 Nm measured during the investigation (paragraphs 79 and 80) and, as noted at paragraph 74, the maximum brake torque that could be obtained for ironman No. E0005087, even with roughened wheels and pads, was just under 40 Nm. In addition, the results at appendix F show no variation between the eight individual readings for each set of measurements; when these ironmen were tested on behalf of the RAIB, the average standard deviation within each set of readings was 2.4 Nm. The mobile fitter stated that he had filled in the MS088-01 form after completing the measurements.
- 87 The mobile fitter also stated that he routinely roughened the surfaces of the wheels and brake pads as part of his servicing routine, if necessary using sandpaper or wire wool. MAN/M/O/105 states that any dirt or oil should be removed from the working surfaces before testing the brakes (appendix D), while MS088 requires brake pads to be checked for contamination and wear and cleaned or replaced as necessary. The RAIB did not observe any contamination of the wheels prior to its testing of the ironmen (paragraph 78), so it was not necessary to clean them. However, this is a possible difference between the condition of the ironmen in this series of tests and their condition when they were last maintained (paragraph 74).
- 88 Torrent Trackside requires its mobile fitters to submit completed maintenance sheets, such as MS088-01, by email to a central mailbox; this provided an opportunity to check the credibility of results obtained by its mobile fitters. Although Torrent Trackside checked that these maintenance sheets were being submitted, it had no process to examine or audit the results at the time of the runaway on 1 November 2014, so the opportunity was missed.
- 89 The brake testing carried out by Torrent Trackside therefore did not identify that the brake torque from each of the two runaway ironmen was probably less than the specified minimum average of 40 Nm when they were last serviced (paragraph 80).

Wear of the brake pads

- 90 Witness evidence indicates that the track workers were 'feathering' the brakes (ie varying the force they applied to the brake handles) to control the speed of the rig on the gradient below GCG. This meant that the brake pads were constantly being worn by contact with the wheel tread. Since the brake cables on the two ironmen were already in tension (paragraphs 79 and 80), the effectiveness of the brakes was continually being reduced to the point where a total loss of brake force occurred. The wear rate would also have been increased with the speed of the ironmen (paragraph 60). The four brake pads on the two ironmen were observed to have worn by between 0.8 and 2.4 mm after the incident.

- 91 The amount of energy dissipated by the brakes on the incident rig during the runaway can be estimated. However, the manufacturer of the friction material has been unable to advise on the amount of energy required to wear the brake pads by a known amount due to the number of variables involved, such as temperature, sliding velocity and contact pressure. The RAIB has therefore been unable to estimate the extent of the observed brake pad wear that occurred during the incident on 1 November 2014 in comparison with that which had taken place previously (paragraph 81).

Possible contamination of the brakes

- 92 As well as the reported heavy rain, the runaway occurred at a time of leaf fall (figure 13). Subsequent examination of the ironmen revealed the presence of leaf contamination on the brake pads (figure 14); it is possible that this may have reduced the friction between the pads and wheel treads. There was no evidence that leaf contamination had caused the wheels of the ironmen to lock up and slide along the rails, and witness evidence indicated this did not happen.



Figure 13: Garnant Branch line below GCG on 3 November 2014

- 93 The presence of water as the result of heavy rain is not an abnormal condition, and the specification and testing of the brakes included requirements for operation in wet conditions (paragraph 36).
- 94 Chemical analysis of the brake pads did not reveal any leaf contamination embedded in the pads. It is not possible to establish whether the presence of leaf contamination reduced the effectiveness of the brakes.

Possible interference with adjustment of the brakes

- 95 The RAIB has also considered the possibility that Network Rail staff might have interfered with the adjustment of the brakes before the runaway on 1 November 2014. Although it cannot be entirely discounted, the RAIB found no evidence to suggest that it was a factor in the incident.



Figure 14: Leaf contamination of brake pad (ironman No. E0005087) on 3 November 2014

- 96 Torrent Trakside has reported a number of instances in which the adjustment of the brakes of Network Rail's manually propelled plant has been interfered with. These include slackening ironmen brake cables, to make it easier to depress the handle and release the brake (figure 15), and tying off brake handles with rope or cable ties.
- 97 The RAIB has seen no evidence of track maintenance staff illicitly tightening (as opposed to slackening) the brake cables on ironmen, and considers that tying off the brake handles would be a quicker, easier and more effective means of releasing the brakes. The original lengths of the brake adjusters (figures 10 and 11) also indicate that they had not been tightened to reduce the brake force. The tension that was observed in the brake cables of the ironmen after the incident was probably the consequence of wear of the brake pads during the descent of the Garnant Branch line.



Figure 15: Evidence of interference with ironman brake adjustment (courtesy Torrent Trackside)

Identification of underlying factor

The lack of clarity about the intended function of the brake

- 98 **None of the relevant standards, codes of practice or manufacturer's instructions define whether the brake fitted to manually propelled plant may be used to control the speed of such plant on gradients.**
- 99 As noted at paragraph 41, none of the documents that define the required performance of the brake fitted to manually propelled plant clarify whether it is intended only for use as a parking brake, as well as occasional use as an emergency brake. In these circumstances, wear of the brake pads would be intermittent and minimal. However, use of the brake as a 'service brake', including controlling the speed of a loaded ironman on a gradient, would result in continual pad wear.
- 100 This lack of clarity in the standards and codes of practice may have allowed the manufacturers of manually propelled plant to design brakes that are unsuitable for use as service brakes, at the same time as allowing the end users of such plant to use the brakes in that way.

Factor affecting the severity of consequences

The warning provided by the track workers

- 101 The track workers' decision to remain with the ironmen and to provide a warning as the rig approached Raven level crossing (paragraph 25) probably prevented a serious accident to one or more of the individuals who were working there at the time.

Observations

The lack of the required pre-use check of the brakes

- 102 CoP0018 states that an operator should carry out a pre-use check of the brakes by gaining access to the wheels of the assembled item of equipment and turning the braked wheels using one hand; the wheels must resist movement. This check is included in Module P514 of Network Rail's Plant Manual and in its training for the ironman competence (PTMP07.01). Witnesses agree that this pre-use check was not carried out after assembling the ironmen at GCG (paragraph 54). Similarly, no such pre-use check was carried out of the trolleys involved in the runaways at Larkhall or Haslemere (paragraphs 108 and 110).
- 103 Although the pre-use brake check was not carried out, the RAIB considers that it would not have been capable of identifying a sub-standard brake torque. On this basis, its absence had no bearing on the occurrence of the incident.

The absence of red lights

- 104 The runaway ironmen were not equipped with the red flags or lights required by Handbook 10 of the Rule Book (paragraph 58).
- 105 Witness evidence indicates that members of the gang working at Raven level crossing would have been unlikely to take evasive action if they had observed one or more red lights approaching them from the direction of GCG. This was because they were expecting the ironmen to have been approaching from this direction and would have been unlikely to realise that the rig was out of control.

Torrent Trackside's competence management regime

- 106 Torrent Trackside has advised that it had combined the assessments of competence for all manually propelled trolleys covered by 'Code of Practice for Safety Critical Maintenance Elements of Small Plant and Equipment', published by RSSB on behalf of the M&E Engineers Networking Group, Ref. CoP0010, as it considered that the safety critical elements were the same.
- 107 Although the ways in which the braking systems of ironmen are adjusted, in particular with respect to the slack required in the brake cables (paragraph G6, appendix G), are different from other types of manually propelled plant such as trolleys, the RAIB accepts that the principles are transferable. The key issue is that the maintenance documentation (MS088 and MS088-01) did not state that slack was required in the cables (paragraph 77).

Previous occurrences of a similar character

- 108 A manually propelled trolley ran away within an engineering possession on the Larkhall branch in the Hamilton area of Scotland on 2 November 2005. The trolley travelled more than 3 miles (4.8 km), reaching speeds above 20 mph (32 km/h), eventually leaving the limits of the possession and running onto a railway line open to traffic ([RAIB report 20/2006](#)).
- 109 A manually propelled trolley being used in connection with engineering works on London Underground's Circle line ran away at Notting Hill Gate on 24 May 2006. The trolley ran down a gradient of 1 in 70 and collided with a stationary trolley of a similar type ([RAIB report 12/2007](#)).
- 110 A manually propelled trolley ran unattended for 2.9 miles (4.6 km) within an engineering possession on the Portsmouth main line near Haslemere on 10 September 2011. The incident occurred when the trolley operator let go of the trolley and the brakes on the trolley failed to apply automatically ([RAIB report 14/2012](#)). Refer to paragraphs 112 to 116.

Previous RAIB recommendation relevant to this investigation

111 The following recommendation, which was made by the RAIB as a result of a previous investigation, has relevance to this investigation.

Previous recommendation that had the potential to address a factor identified in this report

Incident involving a runaway track maintenance trolley near Haslemere, Surrey, 10 September 2011, RAIB report 14/2012, Recommendation 3

112 The RAIB considers that more effective implementation by Torrent Trackside of recommendation 3 in report 14/2012 could have addressed the absence of any reference to slack in ironman brake cables in its maintenance documentation (paragraph 77). This may have affected the adjustment of the brakes on the runaway ironmen.

113 This recommendation read as follows:

Recommendation 3

Torrent Trackside should improve its processes for providing suitable maintenance information, documents and training to its personnel for all of the plant which they may be required to service. The information provided to its staff should be sufficient to enable them to discharge their responsibilities competently and safely.

114 Torrent Trackside advised the ORR (see appendix A for definition) of the actions it had taken in response to this recommendation. These included changes to its processes covering:

- supervision;
- mentoring;
- sharing of best practice;
- the creation of 'champions' for key products;
- competence assessments; and
- fault finding assessments.

115 The ORR subsequently advised the RAIB that Torrent Trackside had taken the recommendation into consideration and taken action to implement it. It therefore concluded that the recommendation had been implemented.

116 The absence of a reference to the requirement for there to be slack in ironman brake cables in Torrent Trackside's maintenance schedule MS088 and maintenance sheet MS088-01 indicates that its processes for capturing manufacturers' requirements were not effective in this instance.

Summary of conclusions

Immediate cause

117 The track workers were unable to control the speed of the rig on the descent towards Raven level crossing (**paragraph 42**).

Causal factors

118 The causal factors were:

- a. The task planning for the work at the level crossing had not adequately mitigated the risk from use of the ironmen on the gradient (**paragraph 45, Recommendation 1**).
- b. The responsibilities of the 'person in charge of the trolley' were not carried out (**paragraph 52, Recommendation 2**).
- c. The speed of the rig was not sufficiently controlled to prevent a runaway (**paragraph 59, Recommendation 2**).
- d. The brakes on the ironmen were unable to control the speed of the rig (**paragraph 66, Recommendations 3, 4 and 5**). This causal factor arose due to a combination of the following:
 - i. The brake springs fitted to the leading ironman were incapable of delivering the specified torque (paragraph 69, **Recommendation 3**).
 - ii. There was insufficient slack in the brake cables of the runaway ironmen (paragraph 77, **Recommendations 3 and 6**).
 - iii. Application of the CoP0018 maintenance brake test by Torrent Trackside did not identify probable poor brake performance (paragraph 82, **Recommendations 3 and 6**).
 - iv. The effectiveness of the brakes was reduced by pad wear due to the long gradient and their continual use to control the speed of the loaded ironmen (paragraph 90, **Recommendation 3**).
 - v. The effectiveness of the brakes may have been reduced due to the presence of water and leaf contamination (paragraph 92, **Recommendation 3**).

Underlying factor

119 None of the relevant standards, codes of practice or manufacturer's instructions define whether the brake fitted to manually propelled plant may be used to control the speed of such plant on gradients (**paragraph 98, Recommendations 3 and 4**).

Additional observations

120 Although not considered to be causal factors, the RAIB observes that:

- a. the pre-use brake check detailed in Module P514 of Network Rail's Plant Manual was not carried out (paragraph 102, **Recommendation 2**);
- b. the runaway ironmen were not equipped with the red flags or lights required by Handbook 10 of the Rule Book (paragraph 104, **Recommendation 2**); and
- c. Torrent Trackside no longer assesses the competence of its mobile fitters separately for ironmen and other types of manually propelled trolleys (paragraph 106, **Recommendation 6**).

Actions reported as already taken or in progress relevant to this report

Actions reported that address factors which otherwise would have resulted in a RAIB recommendation

- 121 Network Rail issued a safety bulletin on 6 November 2014 reminding staff that information on the planning and use of ironmen, including the minimum numbers of people required, is included in specified modules of its Plant Manual.
- 122 Network Rail arranged an 'Ironmen Runaway Learning Event' on 28 May 2015⁹. This was to have been a national 'stand-down day', involving the whole of Network Rail and its contractors. However, the events for some Network Rail departments were deferred and are now due to take place in September 2015. The stated objectives of the learning events are:
- 'to reinforce personal understanding and ownership of the commitments in the safety vision';
 - 'to increase business wide awareness of the circumstances that led up this incident and to enable reflection and learning for all';
 - 'local teams taking ownership and action to help prevent a repeat incident'; and
 - 'to understand the systemic nature of safety risks in the business'.
- 123 Torrent Trackside has advised that it has put arrangements in place to check the validity of the CoP0018 brake test results submitted by its mobile fitters. These are intended to confirm that the results are complete and that the values recorded are credible.

Other reported actions

- 124 Network Rail's safety bulletin (paragraph 121) also prohibited the use of ironmen on gradients steeper than 1 in 150 until further notice.
- 125 Network Rail has commissioned the development of a warning system which is intended to notify track workers of an uncontrolled movement of on-track plant on a gradient above them. Network Rail advises that it has introduced a number of the devices and that further work is under way to learn from early deployment and rollout; it is also considering alternative products. It intends to mandate a process to mitigate the risk of uncontrolled movement of plant.
- 126 At Network Rail's request, Torrent Trackside arranged for additional checks to be made on other plant maintained by the mobile fitter who had serviced the runaway ironmen on 5 September 2014, and for one-to-one supervision to be carried out for one month. During this period, the fitter's supervisor did not identify any instances of poor maintenance or any issues with the fitter's competence.
- 127 Torrent Trackside has prioritised the post-maintenance asset checks that it carries out, based on an assessment of the numbers of defects found for each of its mobile fitters and the safety criticality of the type of equipment being maintained.

⁹ Details at <https://www.safety.networkrail.co.uk/Alerts-and-Campaign/Ironman-learning-event>.

- 128 Torrent Trackside is now routinely reporting evidence found by its fitters of tampering with the adjustment of braking systems on manually propelled plant to Network Rail.
- 129 Permaquip has modified the design of the ironman braking system and states that at the time of writing this report it is seeking the relevant product and engineering acceptance for the redesigned system.

Recommendations

130 The following recommendations are made¹⁰:

- 1 *The intent of this recommendation is for Network Rail to make sure that it takes relevant rules into account and includes appropriate risk mitigations when it plans maintenance work.*

Network Rail should review its arrangements for planning work using manually propelled plant. It should implement any changes necessary so that planners are provided with clear and concise information enabling them to assess the risks associated with the use of such plant on the intended gradients. Safe systems of work should include appropriate mitigation for these risks (paragraph 118a).

- 2 *The intent of this recommendation is for Network Rail to clarify the accountability for compliance with the requirements of the Rule Book.*

Network Rail should review its arrangements for compliance with the requirements of Handbook 10 of the Rule Book, GE/RT8000, specifically the responsibilities assigned to the person in charge of the trolley (paragraphs 118b, 120a and 120b). It should implement any changes necessary to its procedures and competence management processes so that staff on site are always clearly aware of who is accountable for such compliance.

continued

¹⁰ Those identified in the recommendations have a general and ongoing obligation to comply with health and safety legislation, and need to take these recommendations into account in ensuring the safety of their employees and others.

Additionally, for the purposes of regulation 12(1) of the Railways (Accident Investigation and Reporting) Regulations 2005, these recommendations are addressed to the Office of Rail Regulation (also known as Office of Rail and Road) to enable it to carry out its duties under regulation 12(2) to:

- (a) ensure that recommendations are duly considered and where appropriate acted upon; and
- (b) report back to RAIB details of any implementation measures, or the reasons why no implementation measures are being taken.

Copies of both the regulations and the accompanying guidance notes (paragraphs 200 to 203) can be found on RAIB's website www.gov.uk/raib.

- 3 *The intent of this recommendation is for Permaquip to improve the design and maintenance of the ironman braking system, taking account of how it is used.*

Permaquip should carry out a risk assessment of the braking system on the ironman. Starting with a definition of the function of the brake, this should take account of operational experience from end users, the suitability of the brake for use in controlling the speed of loaded ironmen on gradients and possible degradation of the braking performance through the life of the equipment (paragraphs 118d.i to 118d.iv and 119). Additional measures should be integrated into the design of future ironmen by Permaquip. Permaquip should also advise existing owners and operators of ironmen of any need for equipment modifications, changes in operational rules, changes in maintenance instructions and/or additional training.

- 4 *The intent of this recommendation is to ensure that the design and testing of the brakes of trolleys and ironmen is appropriate for their intended use.*

Network Rail, in conjunction with RSSB and the M&E Engineers Networking Group, should define the required functionality of the braking systems fitted to manually propelled plant used on its infrastructure. They should then carry out a generic risk assessment of such braking systems, taking account of all foreseeable failure modes and possible misuse. Based on the findings of this assessment, they should revise the requirements and guidance for design, testing and use of the braking systems, and determine what retrospective action is required with respect to existing equipment (paragraphs 118d and 119).

- 5 *The intent of this recommendation is for Network Rail to implement any measures required to mitigate the risk from runaway of items of manually propelled plant.*

Network Rail should develop a prioritised and time bound plan to implement any mitigation measures necessary to reduce the risk from runaway of existing manually propelled plant to be as low as reasonably practicable (paragraph 118d).

- 6 *The intent of this recommendation is for Torrent Trackside to ensure that its processes for maintaining the braking systems of manually propelled plant, including ironmen, adequately take account of manufacturers' requirements and the differences between types of equipment.*

Torrent Trackside should review its arrangements for ensuring that the braking systems of all types of manually propelled plant are correctly maintained (paragraphs 118d.ii, 118d.iii and 120c). This should include consideration of the required skills and knowledge of its mobile fitters, the maintenance documentation they use, its quality assurance processes and the extent of management oversight. Appropriate action should be taken to address any deficiencies that it identifies.

Appendices

Appendix A - Glossary of abbreviations and acronyms

GCG	Gwaun-Cae-Gurwen
CCTV	Closed circuit television
COSS	Controller of site safety
lbft	Unit of torque measurement (1 lbft = 1.36 Nm)
ORR	Until 1 April 2015 ORR was known as the 'Office of Rail Regulation'. It has used the name 'Office of Rail and Road' for operating purposes with effect from 1 April 2015. Legal force is expected to be given to this name from October 2015
RSSB	The not-for-profit company registered as 'Rail Safety and Standards Board'
SSOW	Safe system of work
STEL	Specialised Tools & Equipment Ltd
TUPE	Transfer of Undertakings (Protection of Employment) Regulations 2006

Appendix B - Glossary of terms

All definitions marked with an asterisk, thus (*), have been taken from Ellis's British Railway Engineering Encyclopaedia © Iain Ellis. www.iainellis.com.

Access point	A designated point along a railway at which entry to railway property may be made safely.*
Brake torque	A measure of the resistance to rotation resulting from a force that is applied at the circumference of a wheel; its units are Newton metres (Nm).
Controller of site safety	A person certified as competent and appointed to provide a safe system of work (SSOW) to enable activities to be carried out by a group of persons on Network Rail infrastructure in accordance with the requirements of the Rule Book (GE/RT8000).*
Engineering possession	The closure of a specific section of line to railway traffic to allow engineering work to take place on the infrastructure in accordance with module T3 of the Rule Book.*
Engineering supervisor	The person nominated to manage the safe execution of works within an engineering worksite.*
Four foot	The area between the two running rails of a standard gauge railway.*
Hazard directory	A database maintained by Network Rail (NR) which contains details of the health, safety and environmental hazards known to exist on Network Rail infrastructure.*
Ironman	A piece of manually propelled equipment used for transporting lengths of rail within an engineering possession.
Person in charge of a possession	The person who manages safe access to the track for work to take place during a possession.
Product acceptance	The process by which Network Rail assures itself that a product complies with relevant standards and is suitable for use on its infrastructure.
Railway Group Standard	A document that mandates technical and operational requirements to members of the railway group, eg Network Rail, train operating companies etc, to ensure that a system, process or procedure interfaces correctly with other systems, processes and procedures.*
Rule Book	Railway Group Standard GE/RT8000, which is the publication detailing the general responsibilities of all staff engaged on the railway system, and the specific duties of certain types of staff such as train drivers and signallers.*
Safe system of work	An arrangement of precautions which ensure that workers are exposed to least possible risk.*

Spring rate	The relationship between the force applied to a spring and its deflection; this is constant in the working range of a simple coil spring.
User worked crossing	A level crossing where the barriers or gates are operated by the user. There is generally no indication of the approach of trains, but a telephone will be provided for contacting the signaller.*

Appendix C - Investigation details

C1 The RAIB used the following sources of evidence in this investigation:

- information provided by witnesses;
- planning documents;
- ironmen maintenance records;
- examination of the runaway ironmen and measurements of brake torque;
- ironman test data;
- signalling data;
- ironmen acceptance records;
- CCTV recordings taken outside a supermarket at GCG;
- site photographs and measurements;
- weather reports and observations at the site;
- chemical analysis of brake pads; and
- a review of previous RAIB investigations that had relevance to this incident.

Appendix D - Extract from User Guide – Ironman (Standard and LUL), Ref. MAN/M/O/105

8 MAINTENANCE

8.2 Brakes

- Remove the brakes and check the brake linings. Remove any dirt or oil from the working surfaces. The recommended minimum thickness of the brake pad lining is 2.5mm.
- Check the operation of the brake to ensure that the brake cables, clevis and rigging screw adjuster are in good condition.
- Lubricate both of the brake pivot pins, clevis pins and the rigging screw adjuster.

The brakes shoes should be completely clear of contact with the wheels when the Brake Handle is held fully down, and in full contact with the wheels when the Brake Handle is released.

With the Brake Handle released and the brakes engaged, the brake cables should be slack.

- To adjust, slacken off the locknuts positioned at the top and bottom of the Rigging Screw Adjuster. Turning the Adjuster in one direction will introduce slack into the brake cable and turning in the opposite direction will reduce slack.
- Once the above set-up is obtained re-tighten the locknuts.
- Test the brake efficiency using the appropriate Brake Test Tool. Ensure that the wheels and brake pads are dry. The brakes should be tested at all four quadrants of each braked wheel and in both directions. The average torque at which the wheel resists movement should be equal or greater than 40 Nm for aluminium wheels and 25 Nm for nylon wheels.
- If the brake torque is not achieved, check and adjust the brakes as described previously and repeat the tests.
- Fix a 'Next Brake Test Due' label onto the Trolley. The date specified must be within 3 months. Complete the Maintenance Brake Test Record Sheet.

Appendix E - Extract from Code of Practice for Rail mounted Manually Propelled Equipment, Ref. CoP0018 issue 5

2.2 Maintenance

2.2.1 Except as shown in 2.2.2 a maintenance brake test should be completed that equates to the following:

- a) Remove the brake shoes and check for wear and contamination, change the brake shoe if the thickness is below the manufacturer's recommendation. If the brake shoes are contaminated, clean or replace as necessary.
- b) Turn the wheel using a suitable torque measuring device (that may be supplied by the manufacturer) to *ascertain a dynamic figure of the torque required to turn the wheel* with the brake applied. Testing should be done with dry wheels and shoes. These figures allow for wet running conditions to meet the braking distances stated in BS EN 13977:2011.
- c) The requirements of 2.2.1b) are best achieved by making each braked wheel turn and *taking the torque reading required to continue the movement*. Readings should be taken in both directions and in all 4 quadrants around the wheel (8 readings per wheel). The average figure should not be below the minimum figures stated in the manufacturer's instructions.
- d) After testing ensure that the brakes can be released.

2.2.2 A manufacturer should provide a maintenance brake test suitable for a particular trolley design at product acceptance which meets the requirements of 2.2.1.

2.2.3 The maintenance brake test should be completed at a periodicity of no greater than three months. The date of the next maintenance brake test should be marked in a suitable, easily seen position, on all trolleys. On rail mounted manually propelled equipment which is in sections, the date of the next maintenance brake test should be displayed on all braked portions only.

2.2.4 A record of the maintenance brake test should be kept. An example of a maintenance brake test record sheet is given in appendix A.

Note: italics added by the RAIB.

Appendix F - Extracts from Torrent Trackside MS088-01 Lightweight Iron Man Maintenance Sheets, dated 5 September 2014

Brake Test Reading (Readings must be taken in both directions and in all 4 quadrants around the wheel (8 readings per braked wheel) and recorded in the table below).				
	Braked Wheel No. 1		Braked Wheel No. 2	
Quadrant 1 Forward	85		77	
Quadrant 2 Forward	85		7	
Quadrant 3 Forward	85		7	
Quadrant 4 Forward	85		7	
Quadrant 1 Reverse	85		7	
Quadrant 2 Reverse	85		77	
Quadrant 3 Reverse	85		7	
Quadrant 4 Reverse	85		77	
Average Torque Reading	85	Lb / Nm	77	Lb / Nm
Comments:				
Fleet number of Torque Wrench used to carry out measurements: WS 01111				

Torque measurements for ironman No. E0005087 (lbft)¹¹

Brake Test Reading (Readings must be taken in both directions and in all 4 quadrants around the wheel (8 readings per braked wheel) and recorded in the table below).				
	Braked Wheel No. 1		Braked Wheel No. 2	
Quadrant 1 Forward	81		88	
Quadrant 2 Forward	81		88	
Quadrant 3 Forward	81		88	
Quadrant 4 Forward	81		88	
Quadrant 1 Reverse	81		88	
Quadrant 2 Reverse	81		88	
Quadrant 3 Reverse	81		88	
Quadrant 4 Reverse	81		88	
Average Torque Reading	81	Lb / Nm	88	Lb / Nm
Comments:				
Fleet number of Torque Wrench used to carry out measurements: WS 01111				

Torque measurements for ironman No. 202003429 (lbft)

¹¹ The table shown is an extract from the actual document provided by Torrent Trackside, and the formatting anomalies in the results for wheel No. 2 are present in the original document.

Appendix G - Description of ironman braking system

G1 Both wheels on one side of an ironman are braked. Permaquip's user guide MAN/M/O/105 describes the ironman brake as 'fail safe'. The brake force is provided by a spring that holds a brake pad against the tread of each braked wheel, resulting in a torque that resists rotation of the wheel. When the operator depresses the brake handle, it pulls a vertical cable upwards, increasing the tension in a horizontal cable (figure G1). In turn, this pulls the brake pads away from the wheel treads (figure G2). The effective length of the vertical cable can be altered by adjusting a turnbuckle, which has locknuts top and bottom.

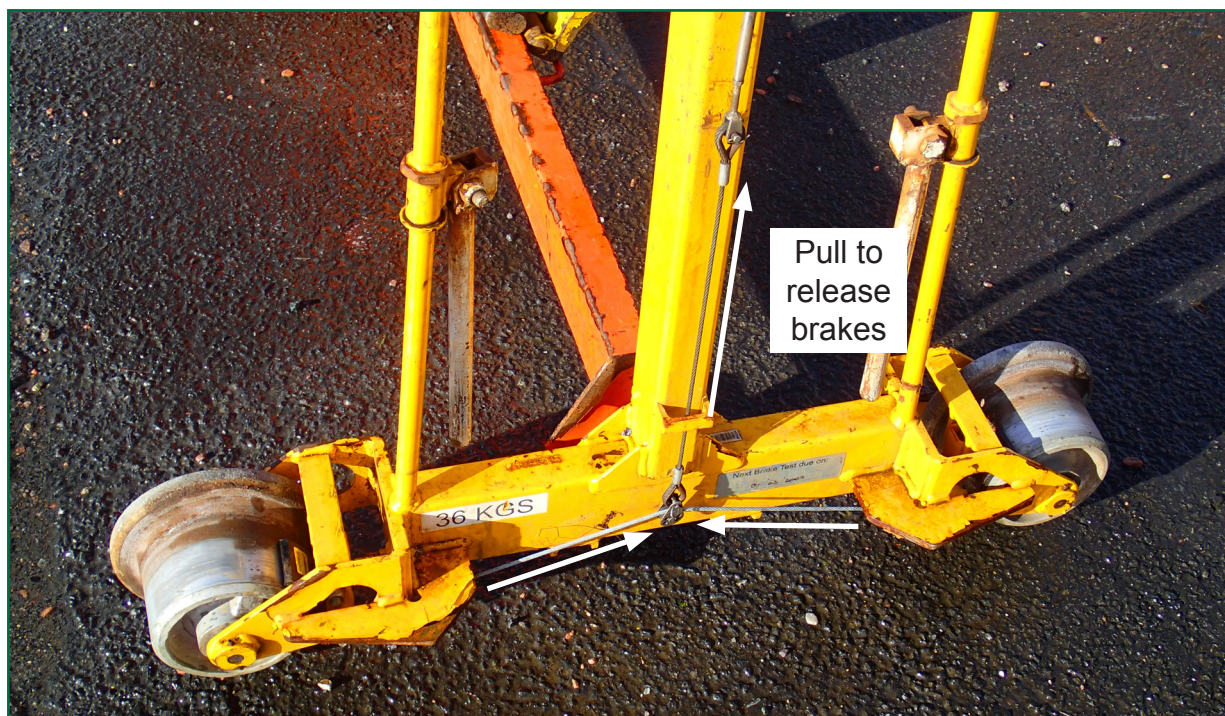

Figure G1: Braked wheels of ironman, showing vertical and horizontal cables; tension in these cables releases the brakes

G2 The required performance of the braking system is specified¹² as a maximum stopping distance for various values of the following parameters:

- Gradient
- Payload
- Speed

The stopping distance is dependent on the brake torque. This is affected by a number of factors, including the cable adjustment, the coefficient of friction between the brake pad and the wheel tread (which is a function of the roughness of both surfaces) and the spring rate. The RAIB has estimated the relationship between torque and stopping distance for the Permaquip ironman using the conditions defined in CoP0018 (figure G3). This demonstrates that reductions in brake torque result in disproportionate increases in the stopping distance. Network Rail observed this effect when it carried out testing of ironmen brake performance following the runaway on 1 November 2014.

¹² The required performance is specified in the following documents: RIS-1701-PLT, BS EN 13977 and CoP0018.

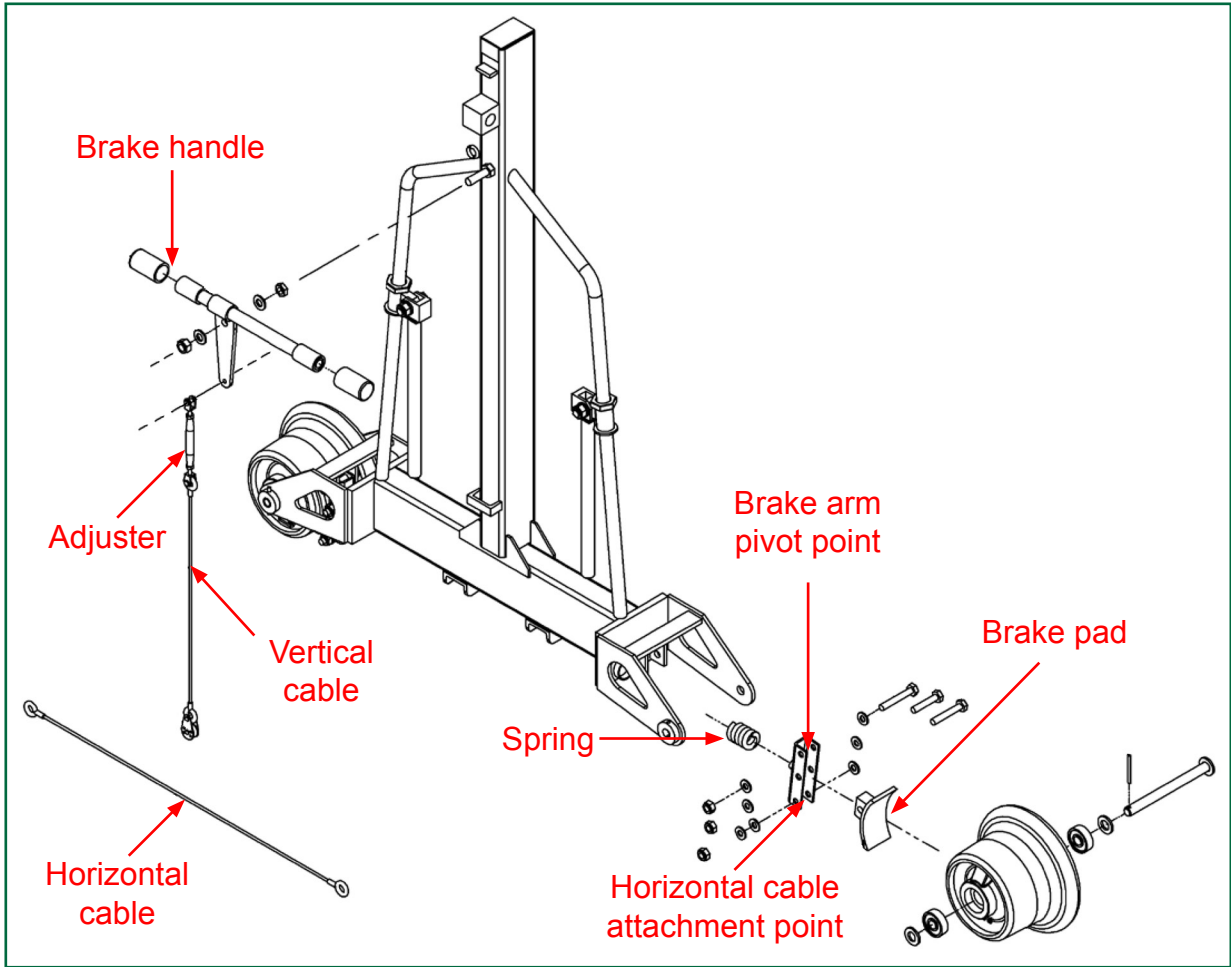

Figure G2: Exploded view of ironman braking system (courtesy Permaquip)

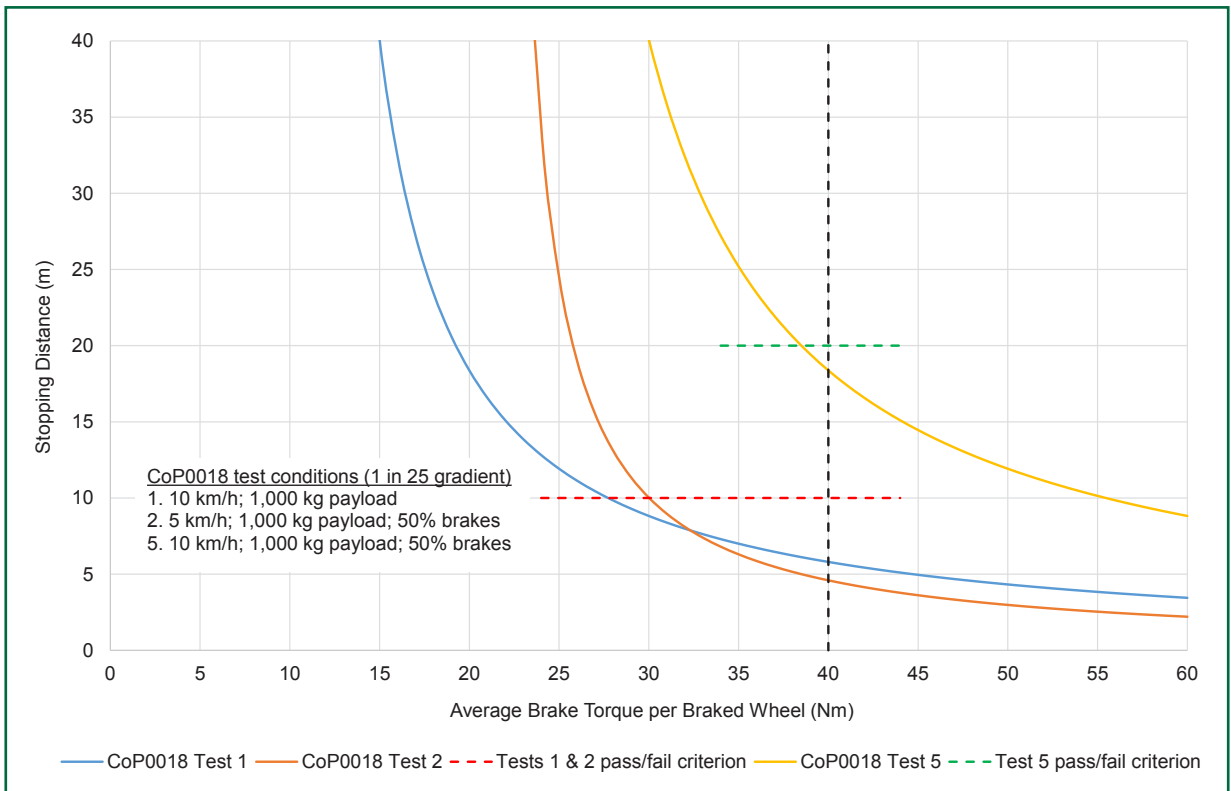

Figure G3: Relationship between torque and stopping distance

G3 Permaquip’s user guide MAN/M/O/105 sets out the requirements for maintenance of the braking system. These include a requirement that the brake pads should be completely clear of the wheels when the brake handle is held fully down, and in full contact with the wheels when the brake handle is released. However, with new brake pads fitted, there is a gap of typically 2 mm at the outside edge of the brake pad (figure G4) because the wheel is tapered and the brake pad is not. Permaquip has been unable to explain why the pad is not designed to sit flush against the wheel tread.

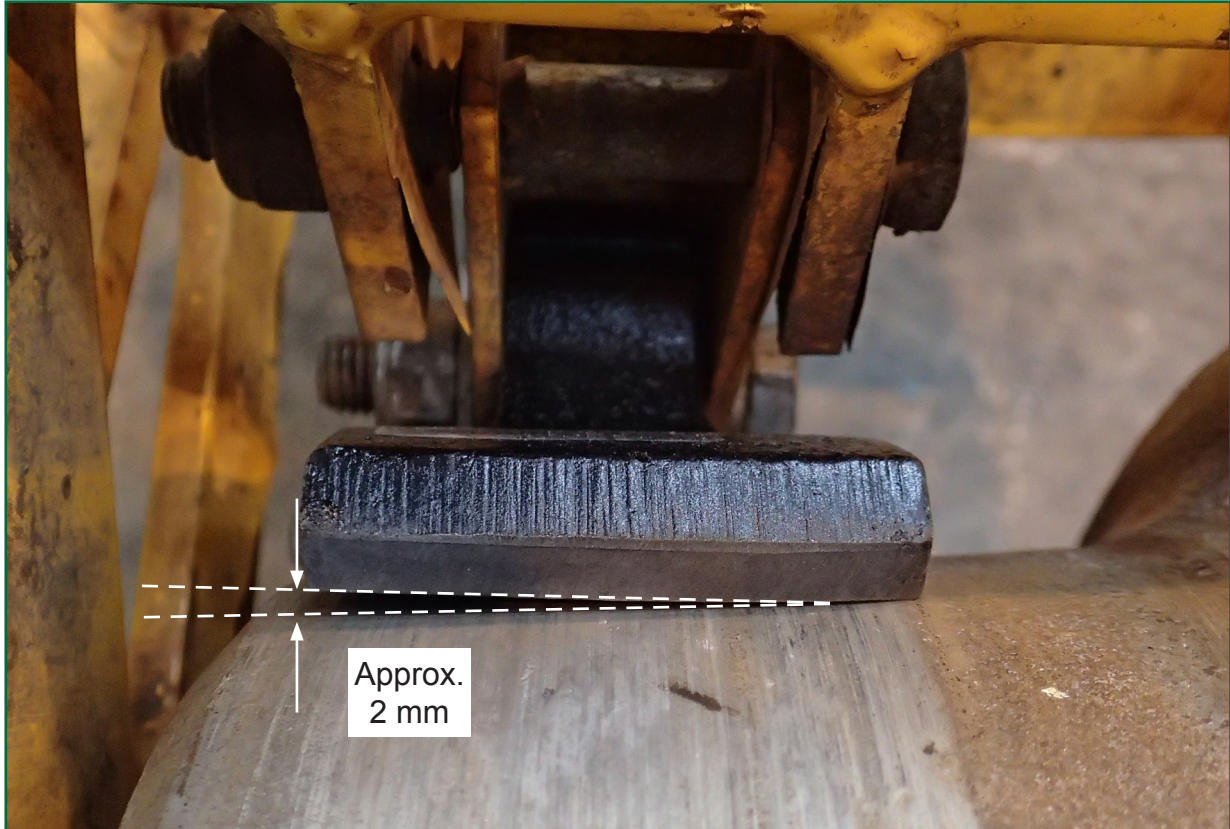

Figure G4: Alignment of new brake pad with wheel tread

- G4 Permaquip’s user guide MAN/M/O/105 also specifies testing of the brake’s effectiveness as part of the maintenance procedure, at a maximum interval of three months. The brake torque should be measured at all four quadrants of each braked wheel, in both directions; the average of the measured torques at which the wheel resists movement should be equal to or greater than 40 Nm.
- G5 The design of the ironman braking system is such that the brake cables tend to come under tension as the brake pad is worn down. Once pad wear exceeds the amount provided for by the slack in the brake cables, the pads are held away from the wheel tread and the brake torque is reduced; eventually this can result in a total loss of braking.

- G6 The maintenance section of Permaquip’s user guide MAN/M/O/105 (appendix D) states that the brake cables should be slack when the brake handle is released and the brakes are engaged, although the extent of slack that is required is not defined. Permaquip advised the RAIB that it typically adjusts the cable slack to make one end of the brake handle approximately 40 to 50 mm lower than the other end when the handle is released and the brakes are applied; this is equivalent to a rotation of approximately 7 to 9° (figure G5 shows a rotation of 14°).
- G7 Specialised Tools & Equipment Ltd (STEL) manufactures a ‘rail handler’ with a very similar design to the Permaquip ironman; this has been approved for use on Network Rail infrastructure and is used by some of Network Rail’s contractors. The User and Maintenance Guide for this device states that the brake cable tension should be adjusted to provide ± 25 mm of lateral movement in the vertical leg of cable when the brakes are applied; this is equivalent to a rotation of approximately $\pm 13^\circ$.

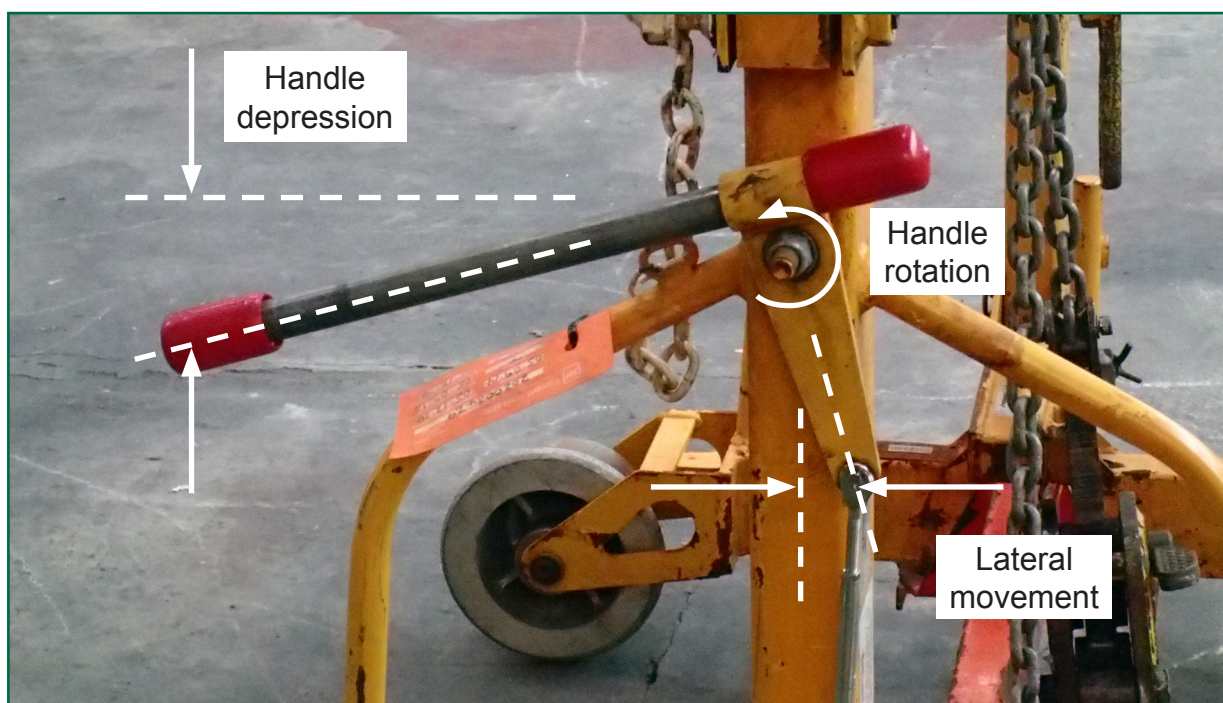

Figure G5: Measurement of slack in the brake cable

- G8 The relationship between the rotation of the handle and the position of the brake pads is shown at figure G6. The amount of free rotation of the handle when it is released corresponds to the slack in the vertical brake cable. As the brake pads wear, the amount of slack reduces; this is equivalent to moving the X axis downwards.

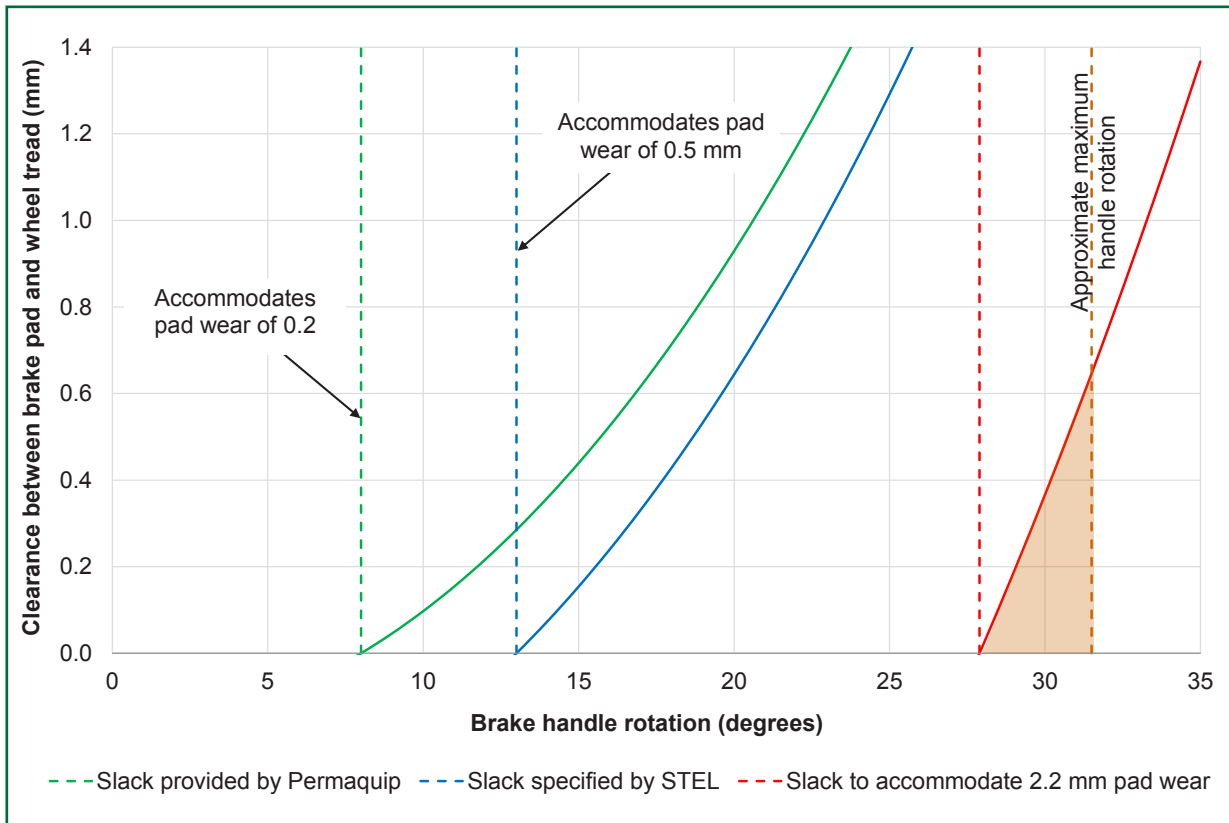

Figure G6: Relationship between brake handle rotation and pad position

G9 The slack normally provided by Permaquip on an ironman leaving the factory is sufficient to accommodate 0.2 mm of pad wear before the cable will remain in tension when the handle is released. The amount of slack specified in the STEL User and Maintenance Guide will accommodate approximately 0.5 mm of pad wear. However, the wear limit before brake pads should be changed during maintenance is 2.2 mm¹³ (in practice, the brakes could be adjusted to compensate for wear in service at successive maintenance intervals before reaching this limit). If sufficient slack was provided to compensate for 2.2 mm of pad wear with new pads fitted, it might not be possible to release the brakes when the handle is depressed fully due to the tolerances and play in the various linkages of the braking system. The limited operating range with this amount of slack is represented by the shaded area in figure G6.

G10 During testing of the runaway ironmen with new brake pads (paragraph 78), the brake pads exhibited noticeable signs of wear, even though they had been used only to resist the rotation of the wheels during the torque testing. The initial wear rate is increased by the angle between the brake pad and the taper of the wheel tread. As noted at paragraph G3, the inside of the pad would need to wear by 2 mm before it is fully bedded in, although this is close to the wear limit of 2.2 mm.

¹³ Brake pads should be changed when the thickness of the friction material is 2.5 mm or less; the RAIB has measured the thickness of the friction material on new pads as approximately 4.7 mm.

This report is published by the Rail Accident Investigation Branch,
Department for Transport.

© Crown copyright 2015

Any enquiries about this publication should be sent to:

RAIB	Telephone: 01332 253300
The Wharf	Fax: 01332 253301
Stores Road	Email: enquiries@raib.gov.uk
Derby UK	Website: www.gov.uk/raib
DE21 4BA	