



Ministry
of Defence



DESSEC-PolSecLE-JSC-WPNS@mod.uk

Defence Equipment & Support
Maple 0a # 2043
MOD Abbey Wood
Bristol BS34 8JH



28-Sep-16

Our Reference:FOI2016/08647



Thank you for your email of 14th September requesting the following information:

Please note the 9 parcels of information have arrived, it took a while to sort everything out, I would be grateful if my thanks can be recorded for all members of staff, 1 item missing is the maintenance manual for the trailer

I am treating your correspondence as a request for information under the Freedom of Information Act 2000 (FOIA). A search for the information has now been completed within the Ministry of Defence, and I can confirm that some information in scope of your request is held. The information you requested can be found attached.

If you are not satisfied with this response or you wish to complain about any aspect of the handling of your request, then you should contact me in the first instance. If informal resolution is not possible and you are still dissatisfied then you may apply for an independent internal review by contacting the Information Rights Compliance team, 2nd Floor, MOD Main Building, Whitehall, SW1A 2HB (e-mail CIO-FOI-IR@mod.uk). Please note that any request for an internal review must be made within 40 working days of the date on which the attempt to reach informal resolution has come to an end.

If you remain dissatisfied following an internal review, you may take your complaint to the Information Commissioner under the provisions of Section 50 of the Freedom of Information Act. Please note that the Information Commissioner will not investigate your case until the MOD internal review process has been completed. Further details of the role and powers of the Information Commissioner can be found on the Commissioner's website, <http://www.ico.org.uk>.

Yours sincerely,





~~FOR OFFICIAL USE ONLY~~
~~CROWN COPYRIGHT RESERVED~~

CONDITIONS OF RELEASE

- 1 ~~This information is released by the UK Government for Defence purposes only.~~
- 2 ~~This information must be afforded the same degree of protection as that afforded to information of an equivalent security marking originated by the recipient Government or as required by the recipient Government's security regulations.~~
- 3 ~~This information may be disclosed only within the Defence Department of the recipient Government, except as otherwise authorized by the Ministry of Defence (Army).~~
- 4 This information may be subject to privately owned rights.

TRAILER LIGHTWEIGHT GS CARGO

MAINTENANCE INSTRUCTIONS REPRINTED INCORPORATING AMDT 1-2

This publication contains information covering the requirements of levels 2 and 3.

BY COMMAND OF THE DEFENCE COUNCIL

Kevin Trew

Ministry of Defence
Issued by
DEFENCE LOGISTICS ORGANISATION

AMENDMENT RECORD

Amdt No.	Incorporated by (Signature)	Date
1	[REDACTED]	30/6/05
2	[REDACTED]	8/6/07
3		
4		
5		
6		
7		
8		
9		
10		
11		
12		
13		
14		
15		
16		
17		
18		
19		
20		
21		
22		
23		
24		
25		
26		
27		
28		
29		
30		
31		

Amdt No.	Incorporated by (Signature)	Date
32		
33		
34		
35		
36		
37		
38		
39		
40		
41		
42		
43		
44		
45		
46		
47		
48		
49		
50		
51		
52		
53		
54		
55		
56		
57		
58		
59		
60		
61		
62		

CONTENTS

PRELIMINARY MATERIAL

	Page
Front Cover	(i)/(ii)
AMENDMENT RECORD	(iii)/(iv)
CONTENTS (this list)	(v)
PREFACE	(vi)
Introduction	(vi)
Related and associated publications	(vi)
Related publications	(vi)
Associated publications	(viii)
List of abbreviations	(viii)
Warnings	(ix)/(x)
Cautions	(ix)/(x)
COMMENT(S) ON AESP*	Final leaf

MAINTENANCE INSTRUCTIONS

Chapter

- 1 General information
- 2 Chassis and body
- 3 Hub assembly
- 4 Suspension
- 5 Brakes
- 6 Jockey wheel and rear support
- 7 Electrics
- 8 Axle assembly

PREFACE**Sponsor: DEC ELS****INTRODUCTION**

1 Service users should forward any comments concerning this Publication through the channels prescribed in Army Equipment Support Publication (AESP) 0100-P-011-013. An AESP Form 10 is provided at the end of this publication; it should be photocopied and used for forwarding comments on this AESP.

2 AESPs are issued under Defence Council authority and, where AESPs specify action to be taken, the AESP will of itself be sufficient authority for such action and also for the demanding of the necessary stores, subject to the provisions of Para 3 below.

3 The subject matter of this publication may be affected by Defence Council Instructions (DCIs), Standard Operating Procedures (SOPs) or by local regulations. When any such Instruction, Order or Regulation contradicts any portion of this publication they are to be taken as the overriding authority.

4 For periods of servicing and lubricants to be used reference must be made to the Maintenance Schedule, Cat 601.

RELATED AND ASSOCIATED PUBLICATIONS**Related publications**

5 The Octad for the subject equipment consists of the categories as detailed overleaf. All references are prefixed with the first eight digits of this publication. The availability of the publications can be checked by reference to the relevant Group Index (refer to AESP 0100-A-001-013).

Category/Sub-category			Information Level			
			1 User/ Operator	2 Unit Maintenance	3 Field Maintenance	4 Base Maintenance
1	0	Purpose and Planning Information	101	101	101	*
	1	Equipment Support Policy Directive	111	111	111	*
	2	Equipment Support Policy Directive	*	*	*	*
2	0	Operating Information	201	*	*	*
	1	Aide Memoire	*	*	*	*
	2	Training Aids	*	*	*	*
3		Technical Description	201	302	302	*
4	1	Installation Instructions	411	411	411	*
	2	Preparation for Special Environments	421	421	421	*
5	1	Failure Diagnosis	201	512	512	*
	2	Maintenance Instructions	201	522	522	*
	3	Inspection Standards	*	532	532	*
	4	Calibration Procedures	*	*	*	*
6		Maintenance Schedules	601	601	*	*
7	1	Illustrated Parts Catalogues	711	711	711	*
	2	Commercial Parts Lists	*	*	*	*
	3	Complete Equipment Schedule, Production	*	*	*	*
	4	Complete Equipment Schedule, Service Edition (Simple Equipment)	741	741	741	*
	5	Complete Equipment Schedule, Service Edition (Complex Equipment)	*	*	*	*
8	1	Modification Instructions	*	*	*	*
	2	General Instructions, Special Technical Instructions and Servicing Instructions	*	821	821	*
	3	Service Engineered Modification Instructions (RAF only)	*	*	*	*

* Category/sub-category not published

Associated publications

6 A full list of associated publications is as follows:

<u>Reference</u>	<u>Title</u>
AESP 2330-E-202	Trailer Lightweight GS Cargo
AESP 2300-A-050-013	B Vehicle Test, Inspection and Certification
AESP 2300-A-110	Vehicle and Trailer Electrical Circuits Installation Checks
AESP 0200-A-221-013	Painting of Service Equipment
AESP 2320-A-300-532	B Vehicle Cab Corrosion Inspection Standards
AESP 2300-A-310-201	B Vehicle Corrosion Prevention
AESP 2300-A-500	Material Quality Assessment - Principles and Practices in REME
AESP 2300-A-600	Waterproofing Regulations-Vehicles and Equipment

LIST OF ABBREVIATIONS

7 The following abbreviations are used in this publication:

AESP	Army Equipment Support Publication
Ah	Ampere Hour
CES	Complete Equipment Schedule
dB	Decibel
dc	Direct Current
DCIs	Defence Council Instructions
EMER	Electrical Mechanical Engineering Regulation
GIE	Government Issued Equipment
LCT	Landing Craft Tank
LST	Landing Ship Tank
NATO	North Atlantic Treaty Organisation
NSN	Nato Stock Number
SOPs	Standard Operating Procedures
UK	United Kingdom

WARNINGS

8 The following WARNINGS are applicable to this equipment.

(1) PERSONAL INJURY. THE TRAILER BODY WEIGHS 120KG. CARE MUST BE TAKEN WHEN LIFTING OR REPLACING THE BODY.

(2) PERSONAL INJURY. ENSURE THE TRAILER IS CHOCKED WHILST WORK IS BEING CARRIED OUT ON THE HUB.

(3) HEALTH RISK. NEVER USE AN AIR LINE TO REMOVE BRAKE DUST, IF INHALED, BRAKE DUST CAN DAMAGE YOUR HEALTH

(4) PRESSURE INCREASE. ENSURE THAT THE LH CALIPER BLEED NIPPLE IS LEFT OPEN WHILST CHARGING THE ACCUMULATOR.

CAUTIONS

9 The following CAUTIONS are applicable to this equipment.

(1) EQUIPMENT DAMAGE. The caliper locating pin and locking R clip can be subject to damage during vehicle use. The caliper locating pin, R clip and spring clip are to be replaced whenever the brake pads are removed.

(2) EQUIPMENT DAMAGE. The space available when removing the master cylinder cover spring clip is limited. Apply caution when using hand tools to prevent damage to the master cylinder and fittings.

CHAPTER 1
GENERAL INFORMATION
CONTENTS

Para

- 1 Scope of repairs
- 2 Threaded fasteners
- 6 Repair kits

Table

Page

1	Torque values for fasteners - non specific	1
---	--	---

SCOPE OF REPAIRS

- 1 This publication covers repairs to be completed at Levels 2 and 3 as indicated below:
 - 1.1 Repairs to the trailer can be carried out at Level 2. Assemblies and components can be adjusted, repaired or replaced.
 - 1.2 Accumulator replacement is to be completed at Level 3 but is described in Chap 5 of this publication.
 - 1.3 Replacement of the axle assembly is to be completed at Level 3 but is described in Chap 8 of this publication.
 - 1.4 Major repairs to the chassis are to be undertaken at Level 3.

THREADED FASTENERS

- 2 Table 1 lists the torque value (Nm and lbf ft) for the range of non specific application fasteners used throughout the equipment.

TABLE 1 TORQUE VALUES FOR FASTENERS - NON SPECIFIC

Fastener Size	Torque Value Nm (lbf ft)			
	Grade A2-70		Grade A2-80	
M3	0.9	(0.7)	-	-
M4	2.0	(1.5)	-	-
M5	4.1	(3.0)	-	-
M6	7.0	(5.2)	9.3	(6.9)
M8	17.0	(12.5)	22.0	(16.2)
M10	33.0	(24.3)	44.0	(32.4)
M12	57.0	(42.0)	76.0	(56.0)
M14	91.0	(67.0)	121.0	(89.2)
M16	140.0	(103.3)	187.0	(138.0)

- 3 The torque value for all specific application fasteners is detailed within the relevant chapter.
- 4 Ensure that the correct fasteners, as indicated in Cat 711, are used when undertaking all repairs. Particular attention is to be given where stainless steel fasteners are in use.
- 5 To achieve the correct torque all stainless steel fasteners are to be lubricated during assembly with low temperature, extreme pressure, grease XG305 (NSN: 9510-99-814-8952).

REPAIR KITS

- 6 Whenever a designated repair kit, as indicated in Cat 711, is used to complete a repair, the full contents of the repair kit must be used.

CHAPTER 2
CHASSIS AND BODY
CONTENTS

Para

- 1 Introduction
- 3 Materials
- Body
- 4 Removal (WARNING)
- 5 Refitting
- Chassis
- 6 General
- Balata belting
- 7 Replacement

Table

		Page
1	Materials	1

Fig

1	Trailer body mountings	4
---	------------------------------	---

INTRODUCTION

- 1 This chapter deals with repairs/replacement of the body and chassis.
- 2 If the chassis is suspected of being damaged or twisted, then it should be backloaded through the normal channels.

MATERIALS

- 3 The materials required to carry out the repairs in this chapter are listed in Table 1.

TABLE 1 MATERIALS

Serial (1)	NSN/Part No. (2)	Designation (3)
1	19180	Double sided tape

BODY**Removal**

4 To remove the trailer body, proceed as follows:

- 4.1 Ensure the handbrake is applied and the jockey wheel is locked in the down position.
- 4.2 Lower and clamp the rear support stands.

NOTE

(1) When removing the mounting bolts note the orientation of the bolts, nuts and washers. Bolts are of different lengths.

(2) When removing the lashing down eyes note the orientation of the bolts, washers and support plates.

4.3 With the aid of an assistant remove:

- 4.3.1 Ten body mounting bolts (Fig 1 (1, 5 and 6)).
- 4.3.2 Six securing shackles (2 and 3).

4.4 Remove the upper mounting bolts (4), complete with washers, securing the number plate to the body (7).

WARNING

PERSONAL INJURY. THE TRAILER BODY WEIGHS 120KG. CARE MUST BE TAKEN WHEN LIFTING OR REPLACING THE BODY.

- 4.5 Raise the Right-Hand (RH) rear corner of the body and remove the number plate.
- 4.6 Disconnect the number plate light plug and stow the number plate clear of the body.
- 4.7 Using suitable slings place them under the body by raising the front and rear.
- 4.8 Using a suitable lifting device remove the body and support on skidding.

Refitting

5 To refit the trailer body, proceed as follows:

- 5.1 Ensure the handbrake is applied, front jockey wheel locked down and rear support stands are lowered and clamped.
- 5.2 Replace the body onto the chassis.
- 5.3 Remove the slings.
- 5.4 Reconnect the electrical plug to the number plate light.
- 5.5 Relocate the number plate between the chassis and body.
- 5.6 Refit the body mounting bolts (1, 5 and 6) in the positions noted in Para 4.
- 5.7 Refit the securing shackles (2 and 3) in the positions noted in Para 4.

- 5.8 Tighten all fasteners.

NOTE

Securing shackles must be free to rotate.

- 5.9 Refit the number plate upper mounting bolts (4).

CHASSIS

General

- 6 Repairs to the chassis is limited to replacement of the balata belting.

Balata belting

Replacement

- 7 To replace the balata belting, proceed as follows:
- 7.1 Remove the trailer body as detailed in Para 4.
 - 7.2 Remove the damaged balata belting.
 - 7.3 Clean the area to be repaired using a suitable cleaner.
 - 7.4 Apply the double sided tape (Table 1, Serial 1) to the area to be repaired.
 - 7.5 Use the existing belting as a template, cut the replacement balata belting to size and shape to fit into place.
 - 7.6 Refit the body as detailed in Para 5.

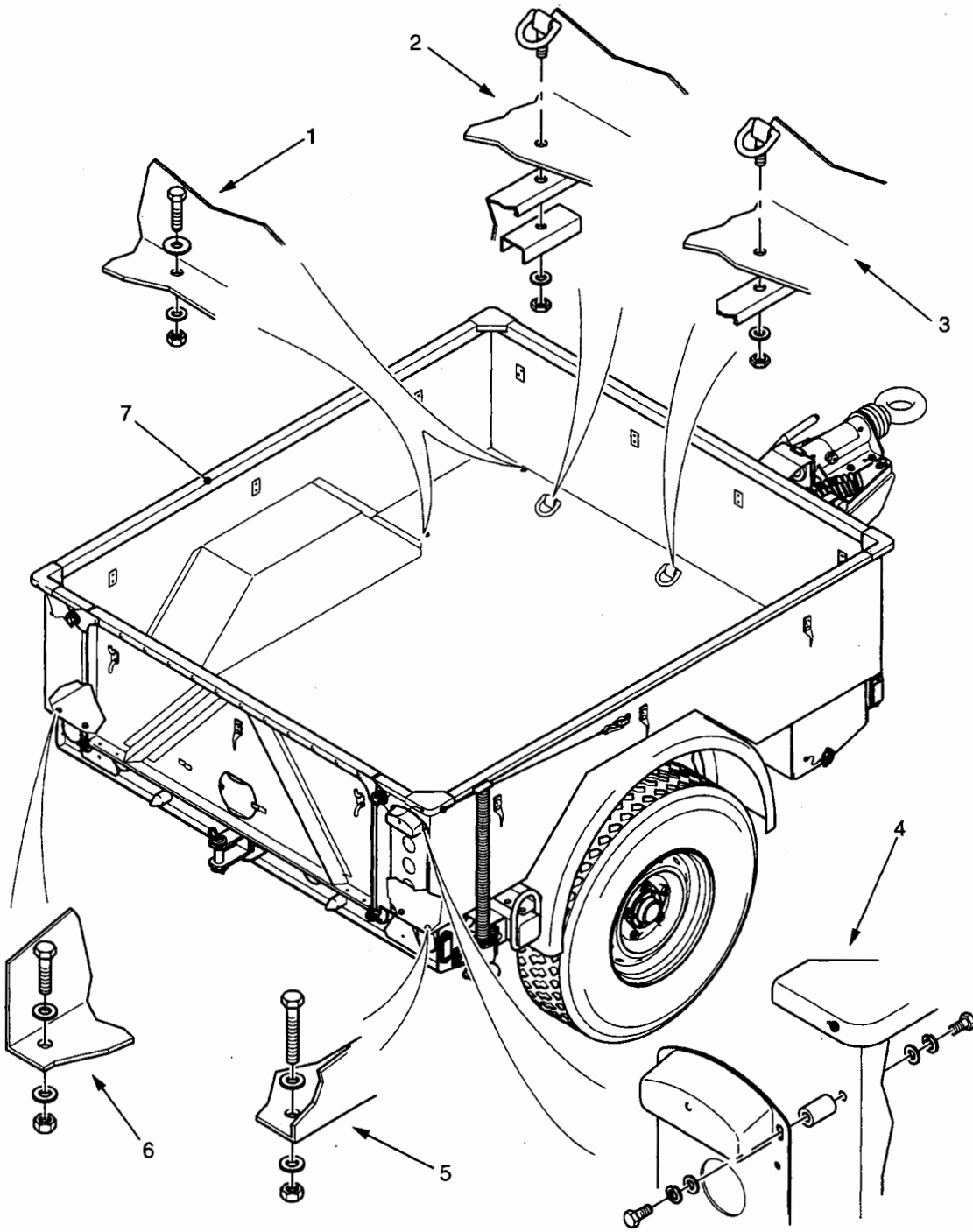

TRL/023

- | | |
|--|---|
| 1 Front mounting bolts | 5 RH rear and number plate mounting bolts |
| 2 LH and RH securing shackle mountings | 6 LH rear mounting bolts |
| 3 Centre securing shackle mountings | 7 Trailer body |
| 4 Number plate upper mounting bolts | |

Fig 1 Trailer body mountings

CHAPTER 3
HUB ASSEMBLY
CONTENTS

Para

- 1 Special tools
- 2 Materials
- Hub assembly
- 3 Checking the hub bearing (WARNING)
- 5 Adjusting the bearings
- 6 Replacing the bearings
- Brake disc
- 7 Replacement

Table

		Page
1	Special tools	1
2	Materials	1

Fig

1	Hub assembly.....	4
---	-------------------	---

SPECIAL TOOLS

- 1 The special tools used in this chapter are listed in Table 1.

TABLE 1 SPECIAL TOOLS

Serial (1)	NSN/Part No. (2)	Designation (3)
1	5120-99-810-8787	Wrench, spanner

MATERIALS

- 2 The materials used in this chapter are listed in Table 2.

TABLE 2 MATERIALS

Serial (1)	NSN/Part No. (2)	Designation (3)
1	9150-99-220-2418	Grease XG 279 (3 kg)

HUB ASSEMBLY

Checking the hub bearing

- 3 To check the hub bearing, proceed as follows:

WARNING

PERSONAL INJURY. ENSURE THE TRAILER IS CHOCKED WHILST WORK IS BEING CARRIED OUT ON THE HUB.

- 3.1 Position the trailer in a suitable work surface and chock the wheels.
 - 3.2 Raise the road wheel.
 - 3.3 Release the handbrake.
 - 3.4 Spin the road wheel and check for freedom of rotation.
 - 3.5 Check for bearing play by rocking the wheel at the top and bottom, in and out.
 - 3.6 The wheel must be free to rotate and have a slight detectable play in the bearings, if not proceed to Para 5.
- 4 If stiffness is felt when rotating the wheel refer to Chap 5 of this publication.

Adjusting the bearings

- 5 To adjust to bearings, proceed as follows:
- 5.1 Remove the six nylon caps and remove the six fixing bolts (Fig 1 (13)) and lock washers (12) from the hub cap (15), discard the lock washers.
 - 5.2 Remove the hub cap and hub gasket (16).
 - 5.3 Tap open the tab washer (18) clear of the outer hub nut (17).
 - 5.4 Remove the outer nut.
 - 5.5 Tap the tab washer clear of the inner hub nut (19), discard the tab washer.
 - 5.6 Using the wrench, spanner (Table 1, Serial 1), complete with a suitable torque wrench, tighten the inner hub nut to 270 Nm (199 lbf ft). Rotate the road wheel throughout to fully seat the bearings.
 - 5.7 Back off the inner hub nut one complete turn or until it becomes loose.
 - 5.8 Re-tighten the inner hub nut to 68 Nm (50 lbf ft), rotate the road wheel throughout.
 - 5.9 Back off the inner nut 1/8 to 1/4 of a turn, to engage with the replacement tab washer, lock the inner hub nut in position.

NOTE

The inner hub nut must be backed off to engage with the tab washer, if not, the bearings may run at higher than normal temperatures during operation.

- 5.10 Refit the outer nut (17) and tighten to 68 Nm (50 lbf ft).
- 5.11 Tap the tab washer to lock the outer nut. If required tighten the outer nut to allow the tab washer to engage in the next available slot.
- 5.12 Refit the hub cap (15) and a new gasket (16), secure using the six bolts (13) and new lock washers (12). Refit the 6 nylon caps.

- 5.13 Apply the handbrake.
- 5.14 Lower the wheel to the floor and remove the chocks.

Replacing the bearings

6 To replace the bearings, proceed as follows:

- 6.1 Position the trailer as a suitable work surface, ensure that the trailer is chocked (wheel not being worked on).
- 6.2 Jack up the wheel to be worked on and support the axle on a vehicle stand.
- 6.3 Release the handbrake and remove the handbrake cable from the caliper as detailed in Chap 5.
- 6.4 Remove the road wheel as detailed in Cat 201, Chap 3.
- 6.5 Remove the brake pads as detailed in Chap 5, Para 2.1 to 2.10.
- 6.6 Remove the two caliper mounting bolts (Fig 1 (4)) and lock washers (5), tie the brake caliper clear of the hub assembly, and discard the lock washers.

NOTE

Do not allow the flexible hose to support the weight of the brake caliper.

- 6.7 Remove the hub cap (15), gasket (16), outer hub nut (17) and tab washer (18) as detailed in Para 5.1 to 5.5.
- 6.8 Remove the inner hub nut (19) and bearing washer (20).
- 6.9 Remove the outer bearing (11) by pulling the hub forwards, then pushing it back.
- 6.10 Remove the hub assembly (10) from the stub axle (24).
- 6.11 Remove the oil seal (22) and inner bearing (21) from the hub. Remove the oil seal ring (23) from the stub axle.
- 6.12 Clean any remaining grease from the stub axle and hub.
- 6.13 Replace the bearing cones in the hub.
- 6.14 Refit the oil seal ring (23) to the stub axle (24).
- 6.15 Refit the inner bearing (21) first re-packing it with grease (Table 2, Serial 1).
- 6.16 Refit a replacement oil seal (22) into the hub.
- 6.17 Re-pack the hub assembly with grease (Table 2, Serial 1), and refit to the stub axle.
- 6.18 Refit the outer bearing (11), first re-packing it with grease (Table 2, Serial 1).
- 6.19 Refit the inner hub nut (19) and bearing washer (20), adjust the bearings as detailed in Para 5.6 to 5.12.
- 6.20 Refit the brake pads as detailed in Chap 5, Para 2.11 to 2.16.

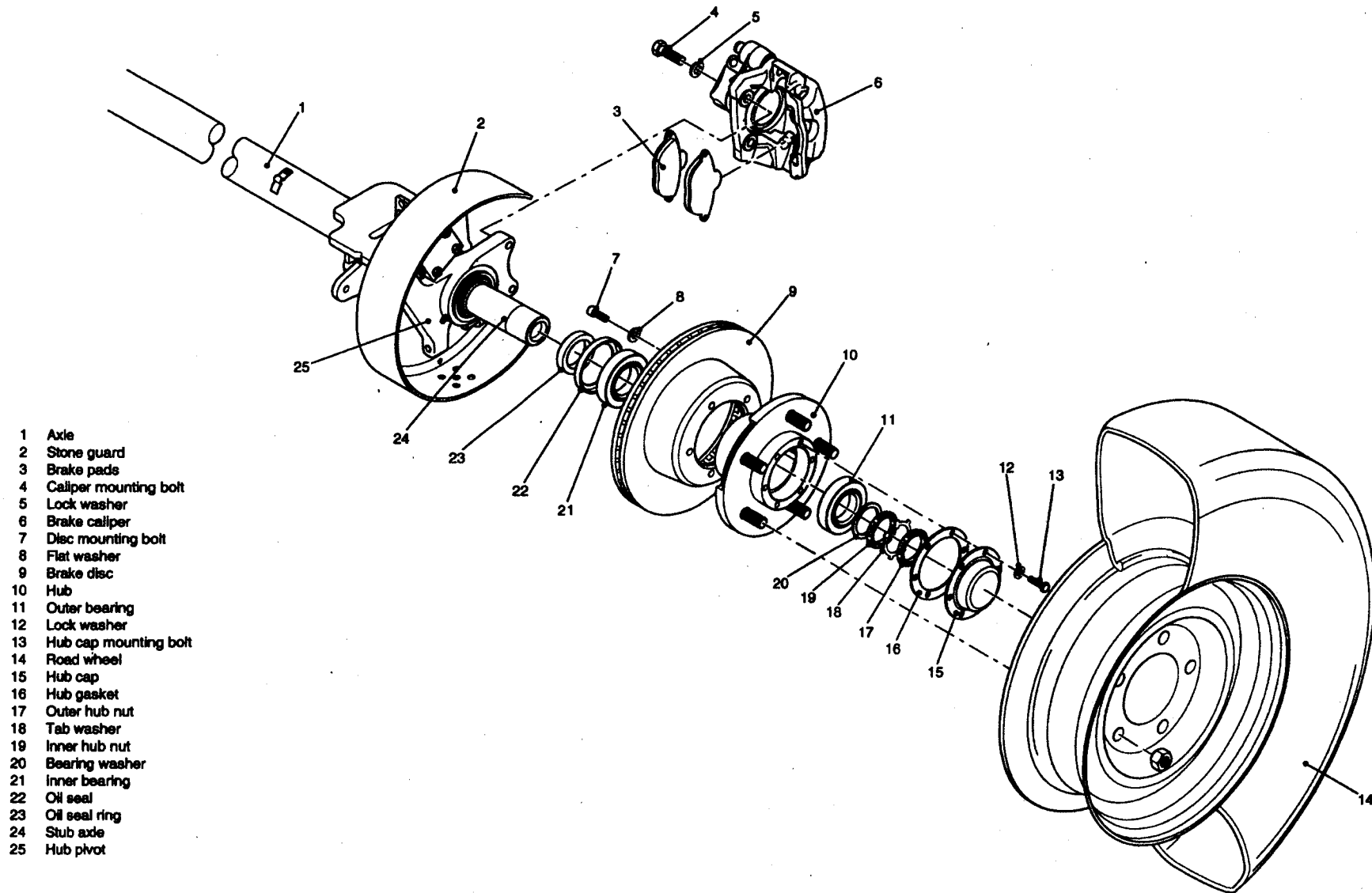

- 1 Axle
- 2 Stone guard
- 3 Brake pads
- 4 Caliper mounting bolt
- 5 Lock washer
- 6 Brake caliper
- 7 Disc mounting bolt
- 8 Flat washer
- 9 Brake disc
- 10 Hub
- 11 Outer bearing
- 12 Lock washer
- 13 Hub cap mounting bolt
- 14 Road wheel
- 15 Hub cap
- 16 Hub gasket
- 17 Outer hub nut
- 18 Tab washer
- 19 Inner hub nut
- 20 Bearing washer
- 21 Inner bearing
- 22 Oil seal
- 23 Oil seal ring
- 24 Stub axle
- 25 Hub pivot

- 6.21 Refit the handbrake cable and carry out handbrake cable adjustment as detailed in Chap 5.
- 6.22 Refit the road wheel as detailed in Cat 201, Chap 3.
- 6.23 Remove the vehicle stand and lower the wheel to the ground.
- 6.24 Test the operation of the handbrake.

BRAKE DISC

Replacement

- 7 To replace the brake disc, proceed as follows:
 - 7.1 Remove the bearings as detailed in Para 6.1 to 6.12.
 - 7.2 Remove the hub (Fig 1 (10)) to a workbench.
 - 7.3 Remove the five bolts (7) and flat washers (8).
 - 7.4 Remove the brake disc (9).
 - 7.5 Ensure the hub (10) is clean and refit a new disc (9) using bolts (7) and flat washers (8). Tighten the bolts to 39 Nm (29 lbf ft). Replace the brake pads (Chap 5) if required.
 - 7.6 Refit the hub as detailed in Para 6.13 to 6.24.

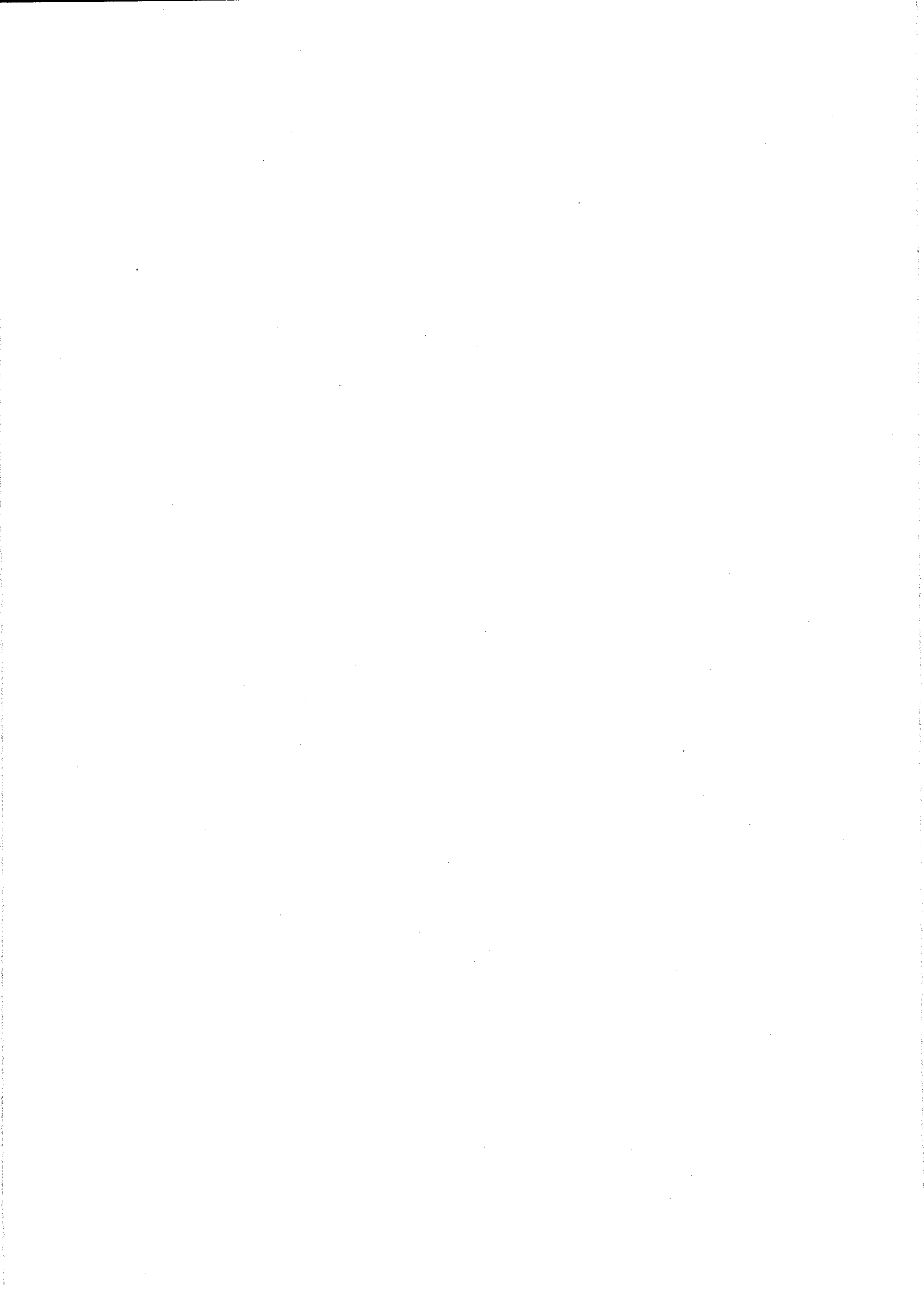

CHAPTER 4
SUSPENSION
CONTENTS

Para

- 1 General
- Road springs
- 2 Removal
- 3 Refitting
- Shock absorber
- 4 Replacement
- Aeon spring
- 5 Replacement
- Anti-roll bar
- 6 Removal
- 7 Refitting
- Check straps
- 8 Replacement

Fig

Page

- 1 Road spring assembly 4
- 2 Anti-roll bar 6

GENERAL

- 1 All self locking nuts, lock washers should be renewed if possible.

ROAD SPRINGS

Removal

- 2 To remove the road spring, proceed as follows:
 - 2.1 Remove the axle check strap as detailed in Para 8.
 - 2.2 Support the front and rear of the trailer on vehicle stands.
 - 2.3 Remove the road wheel as detailed in Cat 201, Chap 3.
 - 2.4 Place a jack under the axle, away from the road spring.
 - 2.5 Remove the shock absorber lower lock nut (Fig 1(9)), flat washer (10), bush (11) and stepped washer (12), and ease away from the clamping plate (6).
 - 2.6 Remove the 2 lowest bolts retaining the stone guard.
 - 2.7 Remove the 4 nuts (8) from the lower clamping plate (6) using a 19 mm extra deep socket, NSN F1 5120-01-046-7300. Remove the nuts nearest the backplate first. Remove the lock washers (7).
 - 2.8 Remove the clamping plate.
 - 2.9 Withdraw the U bolt (15) and both studs (5) (with flat washers uppermost).

- 2.10 Remove the nut and washer from the front mounting bolt (2).

NOTE

The bolt (2) may require tapping out using a brass drift.

- 2.11 With the spring fully supported remove the nuts and threaded plate from the rear shackle mounting bolts (13 and 14).
- 2.12 With assistance remove the 3 mounting bolts from the spring shackles and withdraw the spring from the trailer.
- 2.13 Remove the bush from the chassis shackle eye.

Refitting

- 3 To refit the road spring (Fig 1 (1)), proceed as follows:
 - 3.1 Refit the bush in the chassis shackle eye.
 - 3.2 Refit the thrust washers to the front spring bush (grease aids retention).
 - 3.3 Refit the spring into the front spring shackle, fit the bolt (12), nut and washers loosely.
 - 3.4 Raise the spring up to the axle and locate the centre bolt into the hole in the axle.
 - 3.5 Fit U bolt (15) or studs (5) (with flat washers uppermost) and locate clamping plate (6) nuts (8) and lock washers (7), tighten to 25 Nm (18 lbf ft).

NOTE

The near side is different in that it has two U bolts and no studs.

- 3.6 Jack up axle and locate rear swinging shackle bolts (13 and 14), washers and threaded plates.
- 3.7 Screw the bolts into the threaded plates, refit nuts.
- 3.8 Tighten the U bolts or studs to 40 Nm (29.5 lbf ft).
- 3.9 Tighten all three mounting bolts (2, 13 and 14) to 187 Nm (138 lbf ft).
- 3.10 Tighten the nuts on the rear mounting bolts to 187 Nm (138 lbf ft).
- 3.11 Tighten U bolts or studs to 99 Nm (73 lbf ft).
- 3.12 Refit the 2 lowest bolts retaining the stone guard.
- 3.13 Refit the shock absorber (16) lower mounting with its bushes (11) and stepped washers (12) into the clamping plate, secure with nut (9) and washer (10) and tighten to 33 Nm (24 lbf ft).
- 3.14 Refit the road wheel as detailed in Cat 201, Chap 3.
- 3.15 Remove the jack and vehicle stands from the trailer and lower to the ground.
- 3.16 Refit the axle check straps.
- 3.17 Test the trailer under load.

SHOCK ABSORBER

Replacement

- 4 To replace a shock absorber, proceed as follows:
 - 4.1 Ensure the handbrake is fully on.
 - 4.2 Support the front and rear of the trailer on vehicle stands.
 - 4.3 Remove the shock absorber (Fig 1(16)) lower mounting nut (9), washer (10), bush (11) and stepped washer (12). Note the orientation of the washers for replacement purposes.
 - 4.4 Ease the shock absorber from the clamping plate (6).
 - 4.5 Whilst supporting the shock absorber remove the top mounting bolt (17), nut and washers.
 - 4.6 Remove the shock absorber from the chassis cross-member complete with thrust washers, bushes and sleeve.
 - 4.7 Refit the top bushes, sleeve and thrust washers into the shock absorber eye and refit to the chassis cross-member.
 - 4.8 Refit the top mounting bolt (17) nut and washers and tighten to 76 Nm (56 lbf ft).
 - 4.9 Refit the washer (10), new bush (11) and stepped washer (12) onto the shock absorber and fit into the clamping plate (6).
 - 4.10 Refit the stepped washer, bush, washer and nut (9) and tighten to 33 Nm (24 lbf ft).
 - 4.11 Remove the vehicle stands.

AEON SPRING

Replacement

- 5 To replace the Aeon spring, proceed as follows:
 - 5.1 Ensure the handbrake is on fully and chock the wheels.
 - 5.2 Remove the axle check strap as detailed in Para 8.
 - 5.3 Jack up the chassis away from the axle and support to give clearance between the axle and Aeon spring.
 - 5.4 Remove the bolt (3), plain washer, washer, nut, washers (2 off) and lock washer, remove the Aeon spring (4) and spacer.
 - 5.5 Fit the 2 washers (35 x 3 mm) into the Aeon spring, lubricate the washers and push firmly inside the Aeon spring.
 - 5.6 Refit the Aeon spring and spacer. Refit the bolt (3) complete with plain washer and the nut complete with lock washer. Tighten the nut to 76 Nm (56 lbf ft).
 - 5.7 Jack up the chassis and remove the support.
 - 5.8 Refit the axle check strap.
 - 5.9 Remove chocks and release the handbrake.

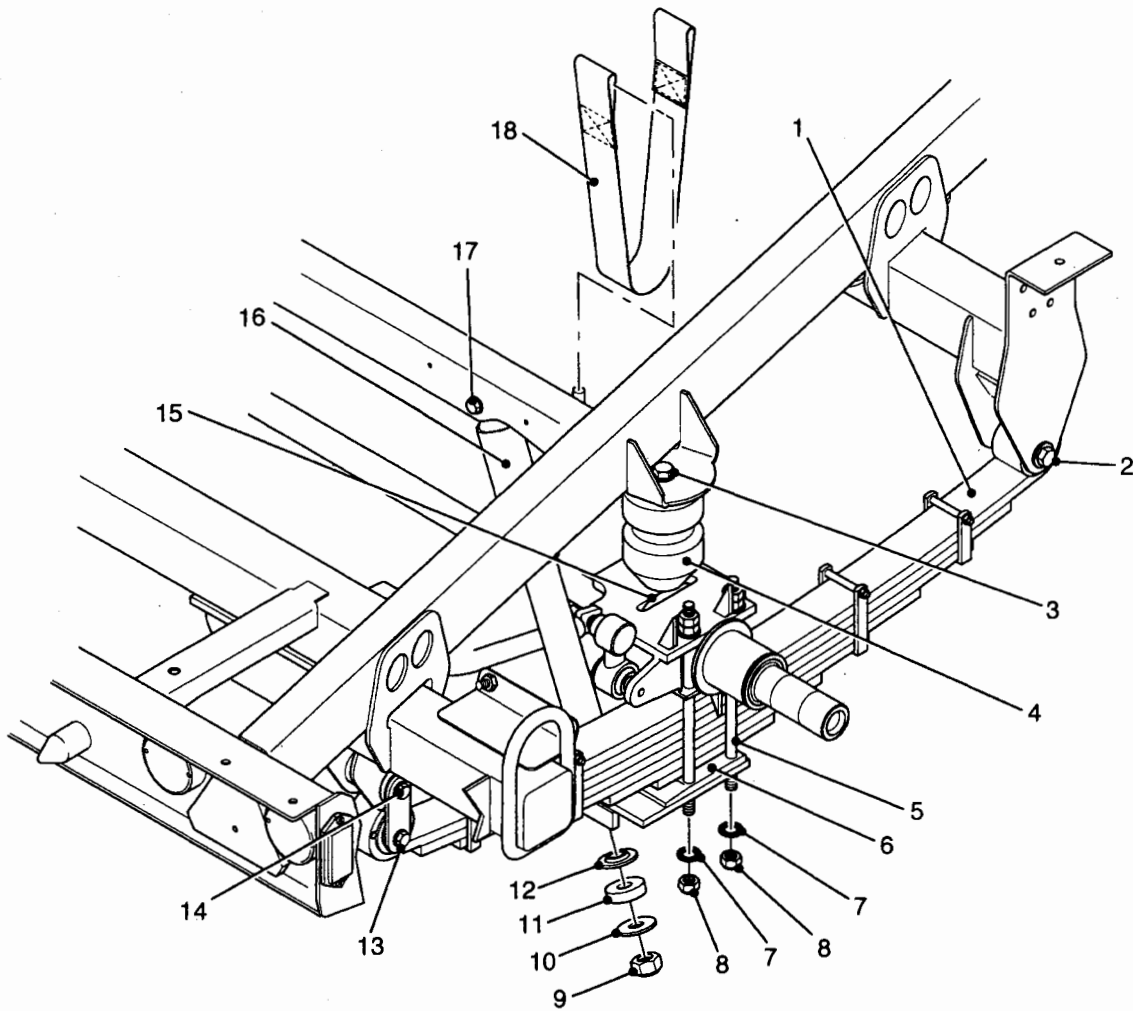

HUB REMOVED FOR CLARITY

TRL/034

- | | | | |
|---|---------------------------|----|---------------------|
| 1 | Road spring | 10 | Flat washer |
| 2 | Mounting bolt | 11 | Shock absorber bush |
| 3 | Aeon spring mounting bolt | 12 | Stepped washer |
| 4 | Aeon spring | 13 | Mounting bolt |
| 5 | Stud | 14 | Mounting bolt |
| 6 | Clamping plate | 15 | U bolt |
| 7 | Lock washer | 16 | Shock absorber |
| 8 | Lock nut | 17 | Mounting bolt |
| 9 | Lock nut | 18 | Axle check strap |

Fig 1 Road spring assembly

ANTI-ROLL BAR

Removal

- 6 To remove the anti-roll bar (Fig 2 (12)), proceed as follows:
 - 6.1 Apply the handbrake.
 - 6.2 Support the trailer at the front and rear on vehicle stands.
 - 6.3 Remove both road wheels as detailed in Cat 201, Chap 3.
 - 6.4 Remove the anti-roll bar top bush brackets (11) by removing bolts (13), washers (14 and 15) and nuts (16) from the trailer chassis.
 - 6.5 Remove the bushes (10) from the anti-roll bar.
 - 6.6 Remove the bolts (6) and lock washers (5) securing the anti-roll bar to the axle. Remove the anti-roll bar from the trailer complete with ball joints (3), bushes (2), flat washers (1) and sleeve (4).
 - 6.7 If required remove the anti-roll bar ball joint by, removing the split pin (7), castellated nut (8) and washer (9).
 - 6.8 Tap the top edge of the flat end section of the anti-roll bar to release the taper and withdraw the ball joint.
 - 6.9 Remove the washers (1), bushes (2) and bush sleeve (4) from the ball joint.

Refitting

- 7 To refit the anti-roll bar, proceed as follows:
 - 7.1 If required refit the ball joint (3) to the anti-roll bar (12) securing it with the nut (8) and washer (9). Tighten the nut to 40 Nm (29.5 lbf ft). If required tighten to align the split pin hole.
 - 7.2 Fit a replacement split pin.
 - 7.3 Refit the bushes (2), sleeve (4) and flat washers (1) to the ball joint.
 - 7.4 With the aid of an assistant, locate the anti-roll bar into the axle mountings. Secure using bolts (6) and lock washers (5). Tighten the bolts to 91 Nm (67 lbf ft).
 - 7.5 Fit the bushes (10) to the anti-roll bar (12).
 - 7.6 Locate the bush brackets (11) and secure to the chassis using bolts (13), washers (14 and 15) and nuts (16).
 - 7.7 Refit the road wheels as detailed in Cat 201, Chap 3.
 - 7.8 Remove the vehicle stands and lower the trailer to the ground.

CHECK STRAPS

Replacement

8 The replacement of the axle check straps (Fig 1(18)) is self-evident and requires no further explanation.

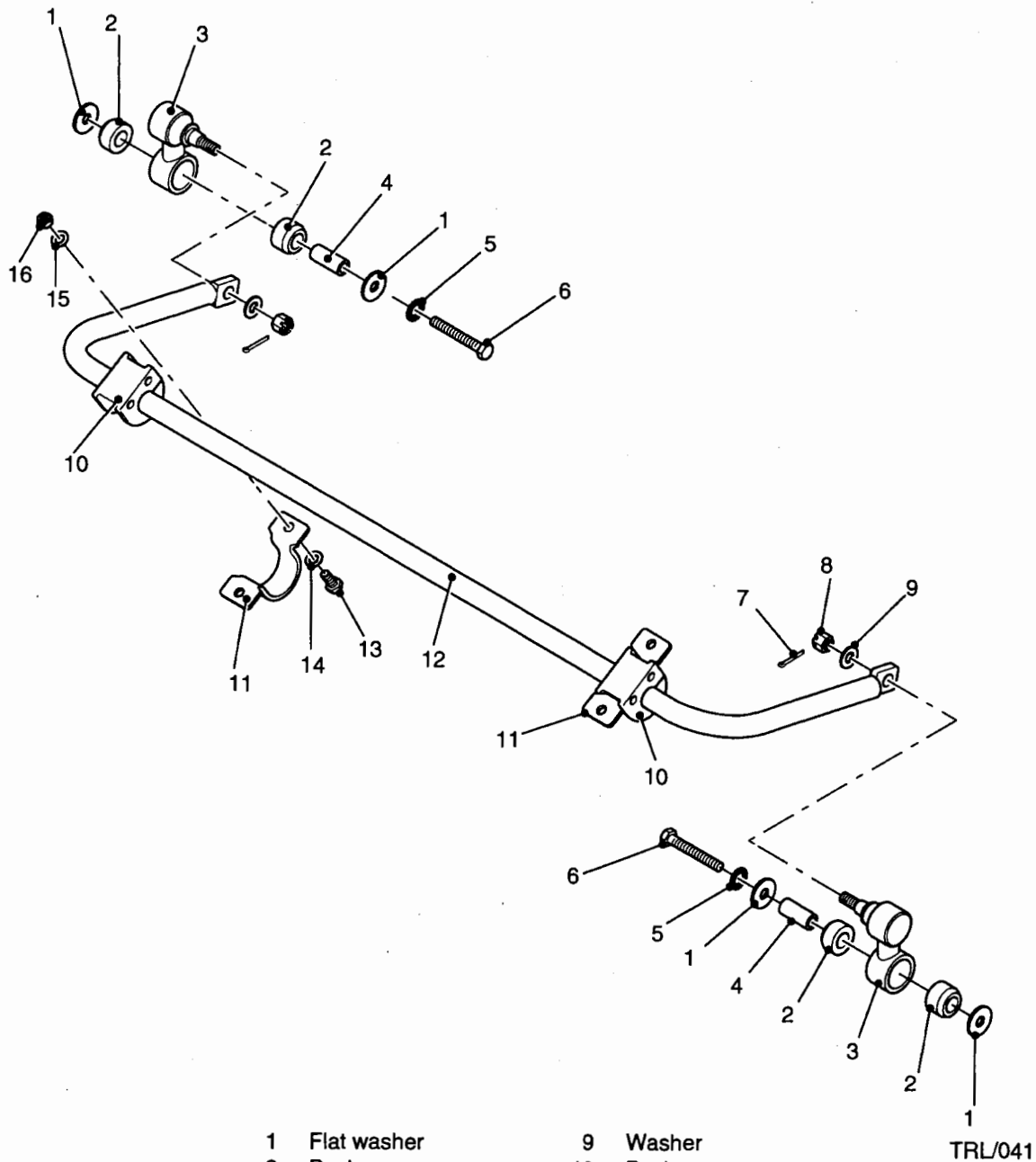

- | | |
|-----------------|------------------|
| 1 Flat washer | 9 Washer |
| 2 Bush | 10 Bush |
| 3 Ball joint | 11 Bush bracket |
| 4 Bush sleeve | 12 Anti-roll bar |
| 5 Lock washer | 13 Mounting bolt |
| 6 Mounting bolt | 14 Flat washer |
| 7 Split pin | 15 Lock washer |
| 8 Nut | 16 Nut |

Fig 2 Anti-roll bar

CHAPTER 5

BRAKES

CONTENTS

Para

1	Special tools
	Brake pads
2	Replacement (WARNING) (CAUTION)
	Brake calipers
3	Removal
4	Refitting
5	Bleeding the brakes (CAUTION)
	Master cylinder
6	Removal
7	Refitting
	Accumulator
8	Removal
9	Refitting (WARNING)
	Handbrake lever
10	Removal
11	Refitting
	Handbrake cable
12	Replacement/adjustment
	Overrun brake damper
13	Replacement (CAUTION)
	Auto-reverse valve
14	General
15	Removal
16	Refitting
17	Bellows replacement
	Pivot hub
18	Removal
19	Refitting
20	Lubrication
22	Master cylinder cover (CAUTION)

Table

	Page
1 Special tools	2

Fig

1 Brake caliper assembly	3
2 Brake components (draw bar)	10
3 Handbrake linkage.....	12
4 Auto-reverse valve removal.....	16
5 Pivot hub lubrication	18

SPECIAL TOOLS

- 1 The special tools used in this chapter are listed in Table 1.

TABLE 1 SPECIAL TOOLS

Serial (1)	NSN/Part No. (2)	Designation (3)
1	4820-99-684-4028	Charging kit

BRAKE PADS**Replacement**

- 2 To replace the brake pads (Fig 1 (7)), proceed as follows:

WARNING

HEALTH RISK. NEVER USE AN AIR LINE TO REMOVE BRAKE DUST, IF INHALED, BRAKE DUST CAN DAMAGE YOUR HEALTH

- 2.1 Position the trailer is suitable work surface. Ensure the trailer is chocked (wheel not being worked on).
- 2.2 Jack up the wheel to be worked on and support the axle on a vehicle stand.
- 2.3 Remove the road wheel as detailed in Cat 201, Chap 3.
- 2.4 Release the handbrake.
- 2.5 Release the handbrake rod locking nuts at the rear of the handbrake rod (Fig 3 (7)) to allow the cable (4 and 5) to be released from the caliper lever.
- 2.6 Remove the cable from the caliper lever.
- 2.7 Remove the R clip (Fig 1 (4)) and tap out the pin (5), also remove the spring clip seated in the caliper (not illustrated).
- 2.8 Swing the caliper (3) body upwards clear of the brake pads (7).
- 2.9 Remove the brake pads.

CAUTION

EQUIPMENT DAMAGE. The caliper locating pin and locking R clip can be subject to damage during vehicle use. The caliper locating pin, R clip and spring clip are to be replaced whenever the brake pads are removed.

- 2.10 Remove the anti rattle spring (6).
- 2.11 Clean the brake pad holders, of dirt and rust.
- 2.12 If the brake pad thickness or brake disc is below that stated in Cat 532 renew.
- 2.13 Refit the anti rattle spring (6).
- 2.14 Refit the pads (7) onto the carrier (8).

- 2.15 Lower the caliper body into position if new pads are to be fitted the caliper piston must be retracted to allow for the new pad thickness. Using a suitable square profile bar turn the piston clockwise to retract it into the caliper ensuring that the pin on the rear of the pad is aligned with the slot in the piston.
- 2.16 Secure using the new pin (5), R clip (4) and spring clips (not illustrated). The spring clip must be fitted with the tongue of the clip facing towards the brake disc. Ensure the R clip is correctly seated on the pin.
- 2.17 Refit the handbrake cable into the caliper and re-connect to the caliper lever.
- 2.18 Refit the road wheel as detailed in Cat 201, Chap 3.
- 2.19 Carry out the operation for the other side of the axle.
- 2.20 Adjust the handbrake as detailed in Para 12.

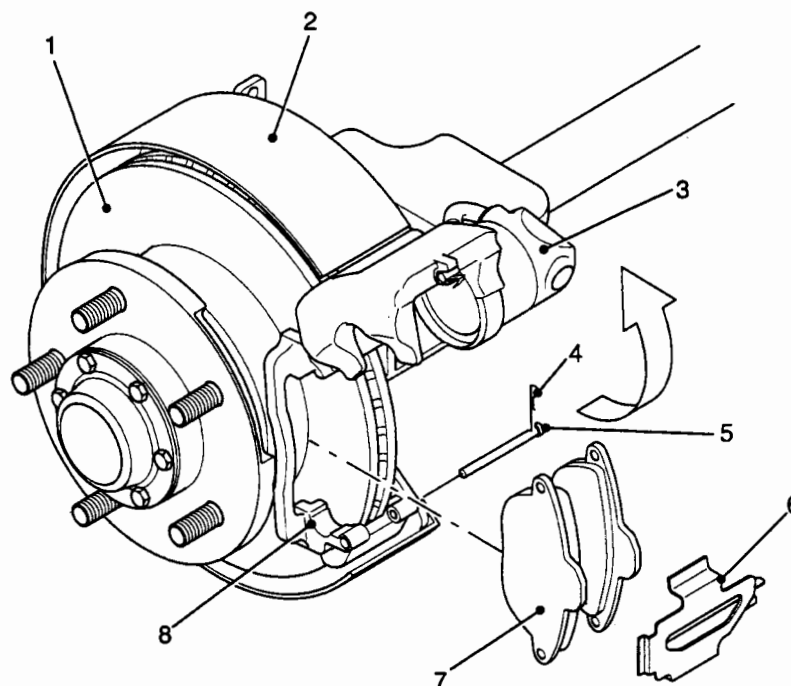

TRL/045

- | | | | |
|---|-------------|---|--------------------|
| 1 | Brake disc | 5 | Caliper pin |
| 2 | Stone guard | 6 | Anti rattle spring |
| 3 | Caliper | 7 | Brake pads |
| 4 | R clip | 8 | Brake pad carrier |

Fig 1 Brake caliper assembly

Brake calipers**Removal**

- 3 To remove the brake caliper, proceed as follows:
 - 3.1 Position the trailer on a suitable work surface. Ensure the trailer is chocked (wheel not being worked on).
 - 3.2 Jack up the wheel and place on a vehicle stand.
 - 3.3 Remove the wheel as detailed in Cat 201, Chap 3.
 - 3.4 Release the handbrake rod locking nuts at the rear of the handbrake rod (Fig 3 (7)) to allow the brake cable (4 and 5) to be released from the caliper and lever.
 - 3.5 Remove the cable from the caliper lever.
 - 3.6 Remove the brake pads (4) from the caliper, renew if required as detailed in Para 2.
 - 3.7 Slacken the 2 mounting bolts securing the caliper (Fig 1(3)) to the caliper mount.
 - 3.8 Using a suitable container for spillage, remove the caliper brake pipe and cap the end of the brake pipe.
 - 3.9 Remove the mounting bolts, complete with washers, and withdraw the caliper from the caliper mount.

Refitting

- 4 To refit the brake caliper, proceed as follows:
 - 4.1 Refit the caliper to the caliper mount and secure using bolts and washers. Tighten to 95 Nm (70 lbf ft).
 - 4.2 Refit the brake pads as detailed in Para 2.14 to 2.16.
 - 4.3 Uncap the brake pipe and refit to the caliper ensuring clearance between handbrake cable and brake pipe.
 - 4.4 Refit the handbrake cable into the caliper and re-connect to the caliper lever. Adjust the handbrake as detailed in Para 12. If both calipers are to be replaced, handbrake adjustment should only be carried out on completion.
 - 4.5 Refit the road wheel as detailed in Cat 201, Chap 3.
 - 4.6 Remove the vehicle stands.
 - 4.7 Bleed the brakes as detailed in Para 5.

BLEEDING THE BRAKES

5 The brakes may be bled using a manual or pressure bleed system where the brake fluid pressure should be within 1.0 to 1.5 bar. For manual bleeding, proceed as follows:

NOTE

On the valve block side of the trailer the stone guard should be removed. It is secured by eight set screws and washers.

5.1 Position the trailer on a suitable work surface and chock both wheels. Release the handbrake. Ensure the Right-Hand (RH) wheel brake caliper assembly is held forward holding the auto-reverse valve open.

5.2 Remove the top plate cover as detailed in Cat 201, Chap 3.

5.3 Remove the top of the reservoir.

CAUTION

EQUIPMENT DAMAGE. During the operations 5.3 - 5.24 take all actions necessary to prevent the ingress of foreign bodies into the brake fluid and reservoir.

5.4 Remove the moisture barrier.

NOTE

The adjustment nut protruding from the back of the coupling and the clevis attached to the brake operating lever is pre-set at the factory and should not require any further adjustment.

5.5 Top up the reservoir with brake fluid (refer to Cat 601).

5.6 Starting at the furthest bleed nipple from the master cylinder (Left-Hand (LH) side).

5.7 Remove the dust cap and attach a bleed pipe. The other end of the pipe should be immersed in a container with a quantity of brake fluid.

5.8 Open the bleed nipple.

5.9 Push the brake operating lever (Fig 2 (11)), with smooth even strokes.

5.10 Repeat this operation until the air has stopped bubbling from the pipe immersed in the container.

NOTES

(1) Observe the level in the reservoir and ensure this level does not drop below the danger level identified on the reservoir body at any time during the bleeding process.

(2) Ensure that the operator topping up the reservoir during the bleeding process does so slowly to minimise the risk of air bubbles entering the brake system.

5.11 Once this state is achieved, the brake operating lever should be held at the end of its stroke (pressure applied). Tighten the bleed nipple.

5.12 Release the brake operating lever smoothly.

- 5.13 Check the reservoir, top up if necessary.

NOTE

If no fluid can be passed through the bleed nipple when fully open, the rotating caliper carrier will require adjusting. This is located on the RH wheel assembly and as will be seen the mechanism is kept in a biased position by the employment of a compression spring. By screwing in the adjustment bolt this will increase the compression on the spring. It is recommended that a distance of 6 mm between the back face of the locking nut and the front face of the bolt be employed, which allows the valve within the valve block to be fully open. Care must however be taken to ensure that the spring is not compressed to its coil bound position and therefore it is recommended that a 5 mm allowance of further travel be left within the spring.

- 5.14 Carry out the bleed cycle on the RH wheel as detailed in Para 5.7 to 5.12.
- 5.15 Check the reservoir, top up if necessary.
- 5.16 With the stone guard removed the auto-reverse valve bleed nipple is on the upper face of the auto-reverse valve.
- 5.17 Repeat the bleed cycle on the auto-reverse valve as detailed in Para 5.7 to 5.12.
- 5.18 Check the reservoir, top up if necessary.

NOTE

To check that the brake system is operating correctly the brake operating lever must be pushed back firmly with the trailer wheels clear of the ground, they should be rotated in the forward direction and should be met with resistance retarding and stopping the wheels. To check the auto-reverse feature rotate the RH wheel backwards, some initial resistance should be felt at which stage the valve will shut off the pressure coming from the brake operating lever and allow the wheel to rotate freely. The LH wheel should also be checked by a second person (it is worthy of note that if the auto-reverse feature is not initiated by rotating the RH wheel and kept in the reverse position the LH wheel will be retarded and held in a locked position).

- 5.19 When the brake test is completed, purging the accumulator (the pressure overload device) should be carried out.
- 5.20 Force the brake operating lever first to its stopped position (brakes hard on), then over to the master cylinder fully stroked position.
- 5.21 A resistance caused by the internal air spring load will be felt against the effort applied, which should be held for 10 seconds.
- 5.22 If any air is seen rising from the bottom of the reservoir during and after Para 5.21 then repeat the bleed cycle as detailed in Para 5.6 to 5.21.
- 5.23 Refit the moisture barrier.
- 5.24 Refit the top of the reservoir.
- 5.25 Refit the top plate cover.
- 5.26 The trailer should now be left for at least 1 hour in an attempt to allow as much air as possible to naturally vent to atmosphere via the master cylinder.

MASTER CYLINDER

Removal

- 6 To remove the master cylinder, proceed as follows:
 - 6.1 Position the trailer on a suitable work surface and chock both wheels. Release the handbrake.
 - 6.2 Remove the top cover (Fig 2 (2)).
 - 6.3 Place a suitable container under the master cylinder to catch any spillage.
 - 6.4 Remove the split pin, washer and clevis pin from the brake operating lever (11).
 - 6.5 Remove the banjo union (3) from the master cylinder, cap the pipe if possible. Examine the copper washers, replace the pipe assembly if required.
 - 6.6 Remove the two mounting bolts (9), nuts and washers.
 - 6.7 Remove the master cylinder from its mounting being careful to avoid spillage.

Refitting

- 7 To refit the master cylinder, proceed as follows:
 - 7.1 Place the master cylinder into its mounting.
 - 7.2 Supporting the master cylinder in its mounting, secure it using the two bolts, nuts and washers. Tighten to 20 Nm (15 lbf ft).
 - 7.3 Refit the clevis pin, washer and new split pin, securing the push rod to the brake operating lever (11). The clevis pin must be replaced if the master cylinder is a replacement item.
 - 7.4 Refit the banjo union (3) to the master cylinder, using new copper washers.
 - 7.5 Bleed the brakes as detailed in Para 5.
 - 7.6 Refit the top cover (2).

ACCUMULATOR

Removal

- 8 To replace the accumulator, proceed as follows:
 - 8.1 Chock the trailer and remove the RH wheel as detailed in Cat 201, Chap 3, Para 3.1 to 3.8. Remove the stone guard.
 - 8.2 Remove the top cover (Fig 2 (2)).
 - 8.3 Remove the two nylon caps from the accumulator mounting plate.
 - 8.4 Loosen the grub screw at the base of the accumulator mounting bracket.
 - 8.5 Place a suitable container under the accumulator to catch any spillage and remove the brake hose from the master cylinder at the banjo union (3).

- 8.6 Remove the brake hose from the rear of the accumulator manifold block (4).
- 8.7 Loosen the two bolts securing the accumulator bracket to the trailer chassis and two bolts securing the accumulator manifold block.
- 8.8 Remove the accumulator assembly including bracket. Remove the bolts securing the manifold to the bracket, separate the manifold and accumulator from the bracket.
- 8.9 Separate the accumulator (7) from the manifold (4), discard the seal.

Refitting

- 9 To refit the accumulator, proceed as follows:
 - 9.1 Refit the accumulator (7) to the manifold using a new seal. Lubricate the seal prior to fitting.
 - 9.2 Refit brake pipes to manifold and master cylinder.
 - 9.3 Remove the master cylinder reservoir cap and moisture barrier.
 - 9.4 Top up the reservoir with brake fluid (refer to Cat 601).
 - 9.5 Open the auto-reverse valve bleed nipple for a period of 10 seconds, (ensuring fluid in the reservoir drops). This allows the fluid into the master cylinder and ensures the master cylinder is not operating dry.
 - 9.6 Close the auto-reverse valve bleed nipple.
 - 9.7 Pump the master cylinder pedal by hand. Maintain the fluid level in the reservoir until all air is expelled from the accumulator, ie no bubbles appear in the base of the reservoir.
 - 9.8 With no bubbles evident at the base of the reservoir, open the LH bleed nipple and attach bleed tube. Pump the master cylinder by hand until fluid runs into the bleed tube. Leave the nipple open.

WARNING

PRESSURE INCREASE. ENSURE THAT THE LH CALIPER BLEED NIPPLE IS LEFT OPEN WHILST CHARGING THE ACCUMULATOR.

- 9.9 Fit the gas charging kit (Table 1, Serial 1) to the base of the accumulator, slacken the grub screw at the base of the accumulator and charge to 91 bar minimum up to 101 bar maximum, lock off using the charging kit knob.
- 9.10 Bleed the LH caliper until no air bubbles are evident. Lock off the bleed nipple.
- 9.11 Bleed the RH caliper until no air bubbles are evident. Lock off the bleed nipple.
- 9.12 Wedge the RH caliper in the reverse mode allowing the auto-reverse valve to close.
- 9.13 Put and hold pressure on once for five seconds. Bleed the RH caliper once.
- 9.14 Wedge the RH caliper in the forward mode holding the auto-reverse valve open.
- 9.15 Bleed the auto-reverse valve as detailed in Para 5.7 to 5.12.
- 9.16 Remove the charging kit, locking off the grub screw at the base of the accumulator.
- 9.17 Refit the accumulator into its bottom bracket.

- 9.18 Refit the four mounting bolts, nuts and washers securing the accumulator manifold block to the mounting bracket and the bracket to the module. Tighten all fasteners to 20 Nm (15 lb ft).
- 9.19 Tighten the grub screw on the base of the bracket.
- 9.20 Ensure that the internal diaphragm in the master cylinder reservoir is replaced correctly as detailed in Cat 201, Chap 3, Para 6.5 NOTE.
- 9.21 Refit the two nylon caps to the accumulator mounting plate.
- 9.22 Through the aperture in the base of the accumulator bracket check the security of the filler grub screw.
- 9.23 Check for fluid leaks.
- 9.24 Refit the top cover.
- 9.25 Refit the stone guard and RH wheel as detailed in Cat 201, Chap 3, Para 4.1 to 4.8.
- 9.26 Test the brakes.

HANDBRAKE LEVER

Removal

- 10 To remove the handbrake, proceed as follows:
 - 10.1 Position the trailer on a suitable work surface and chock both wheels.
 - 10.2 Remove the 2 nylon caps and remove the bolt, nut and washer securing the handbrake rod (Fig 3 (7)) to the handbrake lever (1).
 - 10.3 Remove the nylon cap and remove the nut securing the handbrake lever to the pivot.
 - 10.4 Remove the handbrake lever from the pivot.
 - 10.5 Check the serviceability of the breakaway cable and replace if required.

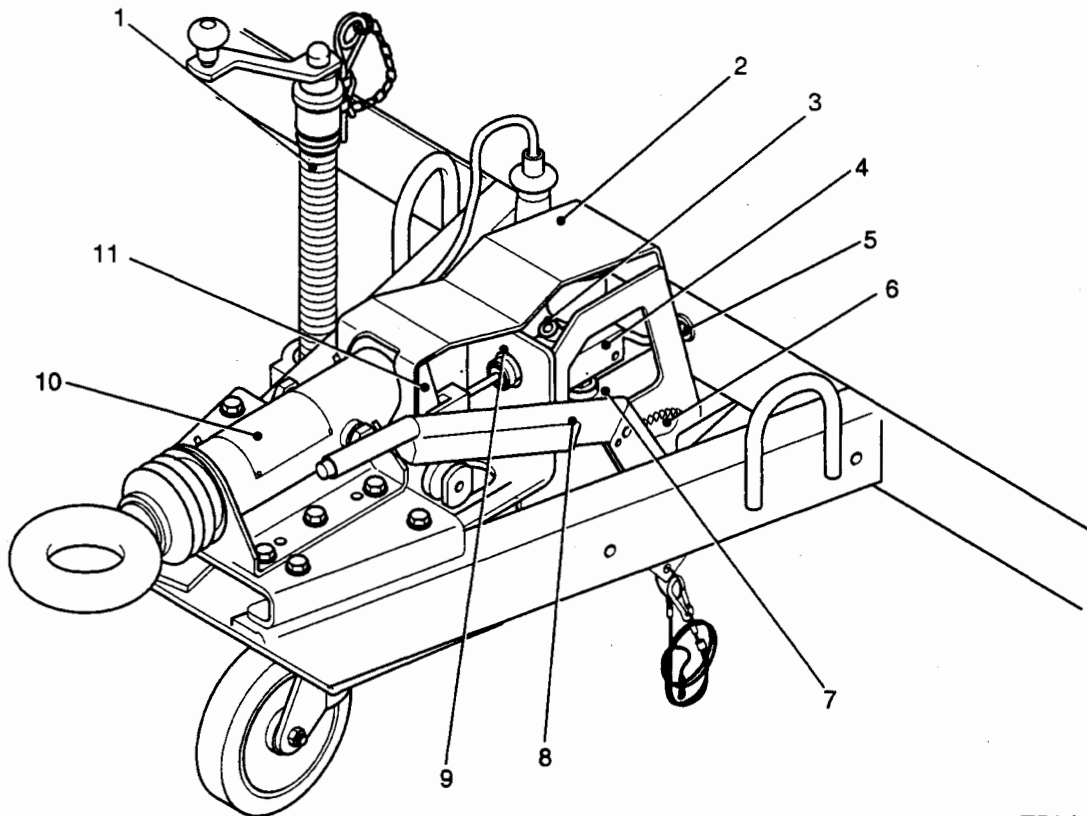

TRL/049

- | | | | |
|---|----------------------------|----|--------------------------------|
| 1 | Jockey wheel assembly | 7 | Accumulator |
| 2 | Cover | 8 | Handbrake lever |
| 3 | Banjo union | 9 | Master cylinder mounting bolts |
| 4 | Accumulator manifold block | 10 | Overrun assembly |
| 5 | Brake pipe | 11 | Brake operating lever |
| 6 | Handbrake quadrant | | |

Fig 2 Brake components (draw bar)

Refitting

- 11 To refit the handbrake, proceed as follows:
 - 11.1 Refit the handbrake lever onto its pivot ensuring the quadrant (8) locates onto the handbrake stop.
 - 11.2 Refit the nut and washer securing the handbrake lever to the pivot. Do not overtighten the nut to ensure handbrake free movement.
 - 11.3 Refit the bolt, nut and washer securing the handbrake rod to the handbrake.
 - 11.4 Check the operation of the handbrake lever.
 - 11.5 Refit the 3 nylon caps to their original positions.
 - 11.6 Remove the chocks.

HANDBRAKE CABLE

Replacement/adjustment

- 12 To replace the handbrake cables, proceed as follows:
 - 12.1 Position the trailer on a suitable work surface and chock both wheels. Ensure the handbrake is in the off position.
 - 12.2 Remove the 2 nuts and shaped washer from the cable at the balance bar (Fig 3 (2)).
 - 12.3 Remove the nut and washer securing the cable to the chassis cross-member.
 - 12.4 On the RH side remove the cable tie securing the cable to the brake hose and pull the cable free. Caution should be applied to prevent damage to the brake hose.
 - 12.5 Release the cable end from the caliper lever arm (6).
 - 12.6 Release the cable from the chassis 'P' clip. The RH cable lock nuts have to be removed to allow removal from the support bracket.
 - 12.7 Withdraw the cable (4 or 5).
 - 12.8 Fit the replacement cable through the cross-member aperture, fit the nut and washer and secure in position.

NOTES

- (1) The cables are to be replaced in pairs.
- (2) The longer of the two cables should be fitted to the auto-reversing valve side.
- 12.9 Loosely fit each cable end through the balance bar (2) with washer and 2 nuts.
- 12.10 Feed the cable through the chassis 'P' clip.
- 12.11 Remove the lock nuts on the RH cable and feed it through the support bracket. Refit the lock nuts.
- 12.12 Insert each new cable through the caliper hole mount and hook the bayonet end fitting to the lever arm (6).

- 12.13 Adjust the lock nuts until 3 or 4 threads show at the lever arm.
- 12.14 Adjust at the balance bar ensuring that the tension in each cable is sufficient to ensure that the cable nipple is restrained by the caliper lever. Tighten the lock nut on the cable.
- 12.15 Pull the handbrake on firmly, at least 2 teeth on the quadrant (8) should be overcome to apply the brakes.
- 12.16 If further adjustment is required it should be done on the brake rod, by shortening the distance between the handbrake lever and the balance bar.
- 12.17 Refit the cable tie to the cable and brake hose ensuring no foul between handbrake cable and brake pipe.
- 12.18 Refit the nut and washer on the chassis cross-member.
- 12.19 Remove the chocks and test the operation of the handbrake.

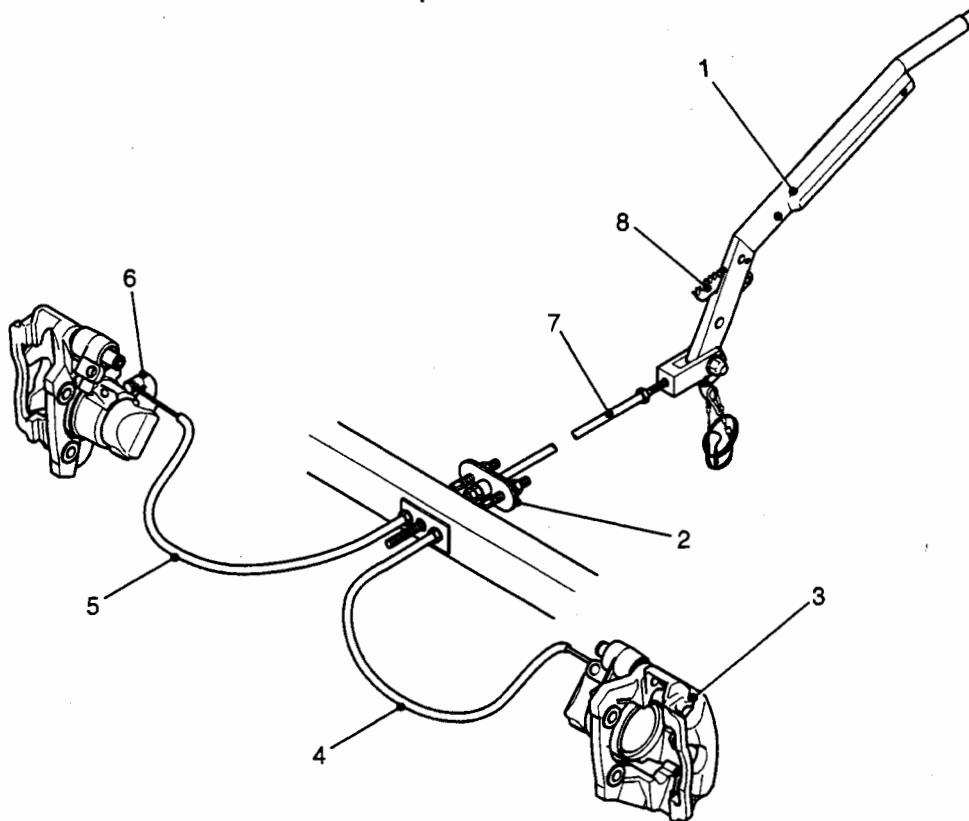

TRL/051

- | | | | |
|---|-----------------|---|-------------------------------|
| 1 | Handbrake lever | 5 | LH brake cable |
| 2 | Balance bar | 6 | Brake cable caliper lever arm |
| 3 | Caliper | 7 | Handbrake rod |
| 4 | RH brake cable | 8 | Handbrake quadrant |

Fig 3 Handbrake linkage

OVERRUN BRAKE DAMPER

Replacement

CAUTION

EQUIPMENT DAMAGE. The overrun damper complies with braking legislation and contains no serviceable parts. Under no circumstances should it be dismantled.

- 13 To replace the overrun brake damper, proceed as follows:
 - 13.1 Position the trailer on a suitable work surface and chock both wheels. Ensure the handbrake is applied.
 - 13.2 Remove the six nylon caps and remove the six bolts, nuts and washers securing the overrun damper assembly (Fig 2 (10)) to the module.
 - 13.3 Remove the overrun damper from the module.
 - 13.4 Refit the new overrun damper onto the module.
 - 13.5 Using the six bolts, nuts and washers secure the overrun damper assembly to the module. Tighten to 95 Nm (70 lbf ft). Refit the nylon caps.
 - 13.6 With the handbrake released screw the adjustment nut in or out until the spherical head is 0.5 mm from the brake operating lever (11). Tighten the locknut.
 - 13.7 Grease the overrun damper, refer to Cat 601.

NOTE

Do not over grease the overrun damper.

- 13.8 Remove the chocks.
- 13.9 Test the trailer.

AUTO-REVERSE VALVE

General

- 14 Repairs to the auto-reverse valve are limited to the removal and refitting of the auto-reverse valve as a complete assembly and repair by replacement of the rubber bellows.

Removal

- 15 To remove the auto-reverse valve, proceed as follows:
 - 15.1 Position the trailer on a suitable level work surface and ensure the trailer is chocked.
 - 15.2 Place an axle stand under the axle, clear of the working area.
 - 15.3 Remove the road wheel as detailed in Cat 201, Chap 3.
 - 15.4 Release the handbrake.
 - 15.5 Release the handbrake rod and remove the cable from the rear of the caliper as detailed in Para 12.

- 15.6 Remove the eight screws complete with washers securing the stone guard (Fig 4 (1)). Withdraw the stone guard clear.
- 15.7 Remove the brake pipes from the auto-reverse valve (6) and use a suitable container for spillage.
- 15.8 Remove the caliper (4) as detailed in Para 3.
- 15.9 Relieve the spring pressure at the bottom of the pivot hub (13) by slackening the lock nut (14) at the base of the pivot hub and wind out the adjustment bolt (15).
- 15.10 Remove the four socket head screws holding the auto-reverse valve (6) to the backplate (17).
- 15.11 Replace the lower caliper bolt in the pivot hub and with a suitable lever rotate the pivot hub counter-clockwise to ease removal of the auto-reverse valve.
- 15.12 Remove the spring bolt and bellows (part of the auto-reverse valve assembly) by holding spring bolt on flats and slacken lock nut (16).

Refitting

- 16 To refit the auto-reverse valve, proceed as follows:
 - 16.1 Refit spring bolt and bellows (part of auto-reverse valve assembly) by holding spring bolt on flats and tighten lock nut (16). Ensure spring bolt is clear of valve block side walls.
 - 16.2 Using a suitable lever rotate pivot hub counter-clockwise to ease replacement of the auto-reverse valve, ensuring that the rubber boot is correctly fitted.
 - 16.3 Tighten the four socket head screws holding the auto-reverse valve to the backplate.
 - 16.4 Adjust the pivot hub tension as follows:
 - 16.4.1 Screw in the adjustment bolt (15) to increase tension on the spring (9).
 - 16.4.2 Adjust the bolt until a distance of 6 mm between the back face of the lock nut (14) and the front face of the bolt is achieved.
 - 16.4.3 Ensure the spring is not coil bound, therefore a further 5 mm allowance of travel is left within the spring. Tighten the lock nut.
 - 16.5 Refit the caliper as detailed in Para 4.
 - 16.6 Refit the brake pipes to the auto-reverse valve.
 - 16.7 Refit and adjust the handbrake cable as detailed in Para 12.
 - 16.8 Bleed the brakes as detailed in Para 5.
 - 16.9 Refit the stone guard (1).
 - 16.10 Refit the road wheel as detailed in Cat 201, Chap 3.
 - 16.11 Remove the axle stand.
 - 16.12 Test the brakes.

Bellows replacement

- 17 To replace the auto-reverse valve bellows (Fig 4 (7)), proceed as follows:
 - 17.1 Proceed as detailed in Para 15.1 to 15.6.
 - 17.2 Remove the brake pads (5) as detailed in Para 2.
 - 17.3 Remove the two mounting bolts securing the caliper (4) to the caliper mount. Remove the caliper, taking care not to damage the flexible pipe, and support on the suspension leaf spring.
 - 17.4 Relieve the spring pressure at the bottom of the pivot hub (13) by slackening the lock nut (14) and winding out the adjustment bolt (15). Ensure that the end of the adjustment bolt is withdrawn into the threaded section of the pivot hub.
 - 17.5 Using a suitable lever force the non fixed end of the pivot hub in a downwards direction until the spring (9) passes the lever arm, the sealing cup (10) can now be removed. Place a suitable punch on the end of the spring at the fixed end and remove from the peg.
 - 17.6 Rotate the pivot hub in a counter-clockwise direction to gain access to the bellows. Replace the bellows ensuring that the plunger and spring remain in position and the bellows is correctly located on the valve block and the push rod.
 - 17.7 Rotate the pivot hub in a clockwise direction and position a suitable clamp between the back face of the valve block and the inner face of the pivot hub. Tighten the clamp sufficiently to retain the maximum gap when the spring is refitted.
 - 17.8 Position the spring onto the end of the peg and place a suitable lever inside the spring 20 mm from the end. With the end of the lever within a coil, push the spring upwards and towards the peg until it locates correctly onto the peg. Place the cup (10) onto the spring, and using the lever against the cup, push the cup and spring until they locate correctly within the pivot hub.
 - 17.9 Adjust the pivot hub tension as detailed in Para 16.4.
 - 17.10 Refit the caliper as detailed in Para 4.
 - 17.11 Refit the brake pads as detailed in Para 2.
 - 17.12 Refit and adjust the handbrake cable as detailed in Para 12.
 - 17.13 Proceed as detailed in Para 16.9 to 16.12.

PIVOT HUB

Removal

- 18 To remove the pivot hub (Fig 4 (13)), proceed as follows:
 - 18.1 Remove the wheel hub, complete with bearings, as detailed in Chap 3, Para 6.1 to 6.10.
 - 18.2 Remove the auto-reverse valve as detailed in Para 15.6 to 15.12.
 - 18.3 Using suitable circlip pliers, remove the circlip (11) retaining the pivot hub in position.

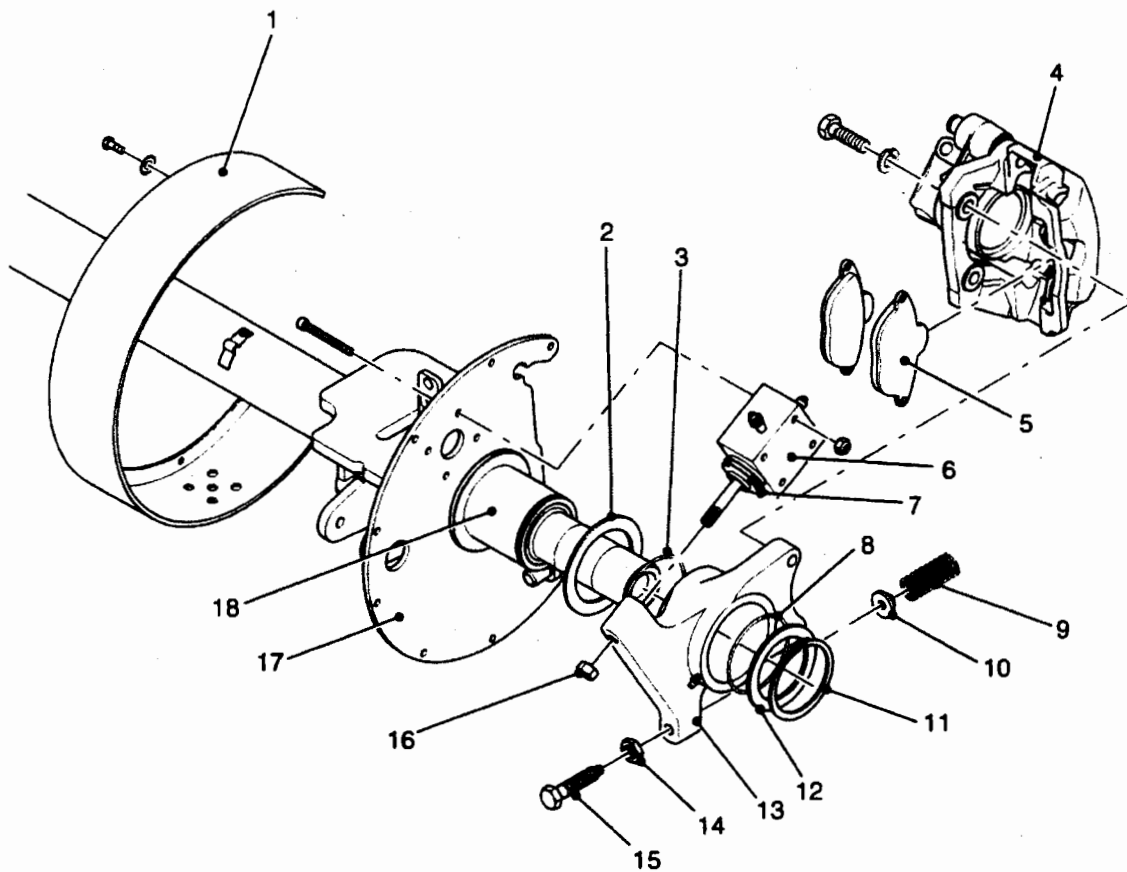

COMPONENTS REMOVED FOR CLARITY

TRL/050A

- | | | | |
|---|----------------------|----|----------------------|
| 1 | Stone guard | 10 | Cup |
| 2 | Inner sealing washer | 11 | Circlip |
| 3 | Inner sealing ring | 12 | Outer sealing washer |
| 4 | Caliper | 13 | Pivot hub |
| 5 | Brake pads | 14 | Lock nut |
| 6 | Auto-reverse valve | 15 | Adjustment bolt |
| 7 | Bellows | 16 | Lock nut |
| 8 | Outer sealing ring | 17 | Backplate |
| 9 | Spring | 18 | Stub axle |

Fig 4 Auto-reverse valve removal

18.4 Withdraw the outer sealing washer (12) (nylon and steel) from the stub axle (18). Note the orientation of the washer for refitting purposes.

18.5 Remove the pivot hub from the stub axle, remove and discard the inner (3) and outer (8) sealing rings. Note the orientation of the hub to the backplate (17).

18.6 Withdraw the inner sealing washer (2), note the orientation of the washer for refitting purposes.

18.7 If required remove the adjustment bolt (15) from the pivot arm.

Refitting

19 To refit the pivot hub (Fig 4(13)), proceed as follows:

19.1 Refit the inner sealing washer (2) to the stub axle (18). Note the orientation, sponge face to the backplate.

19.2 Refit a replacement inner sealing ring (3) to the internal recess in the pivot hub. Ensure the ring is sealed correctly.

19.3 Refit the pivot hub to the stub axle, noting the orientation during removal.

19.4 Refit a replacement outer sealing ring (8) to the internal recess in the pivot hub. Ensure the ring is seated correctly.

19.5 Refit the outer sealing washer (12) to the stub axle. Note the washer orientation, nylon face to the backplate

19.6 Refit the circlip (11) to retain the pivot hub in position.

19.7 Grease the pivot hub, refer to Cat 601.

19.8 Refit the auto-reverse valve as detailed in Para 16.1 to 16.9.

19.9 Refit the wheel hub as detailed in Chap 3, Para 6.1 to 6.19.

19.10 Test the brakes.

Lubrication

20 At intervals detailed in the Cat 601, grease the auto-reverse valve pivot hub grease nipple (Fig 5(2)).

21 To gain access to the auto-reverse valve pivot hub grease nipple proceed as follows:

21.1 Remove the eight screws complete with shakeproof washers securing the stone guard (1) to the brake backplate.

21.2 Withdraw the stone guard sufficient to gain full access to the pivot hub grease nipple. Apply grease as detailed in Cat 601.

21.3 Refit and secure the stone guard.

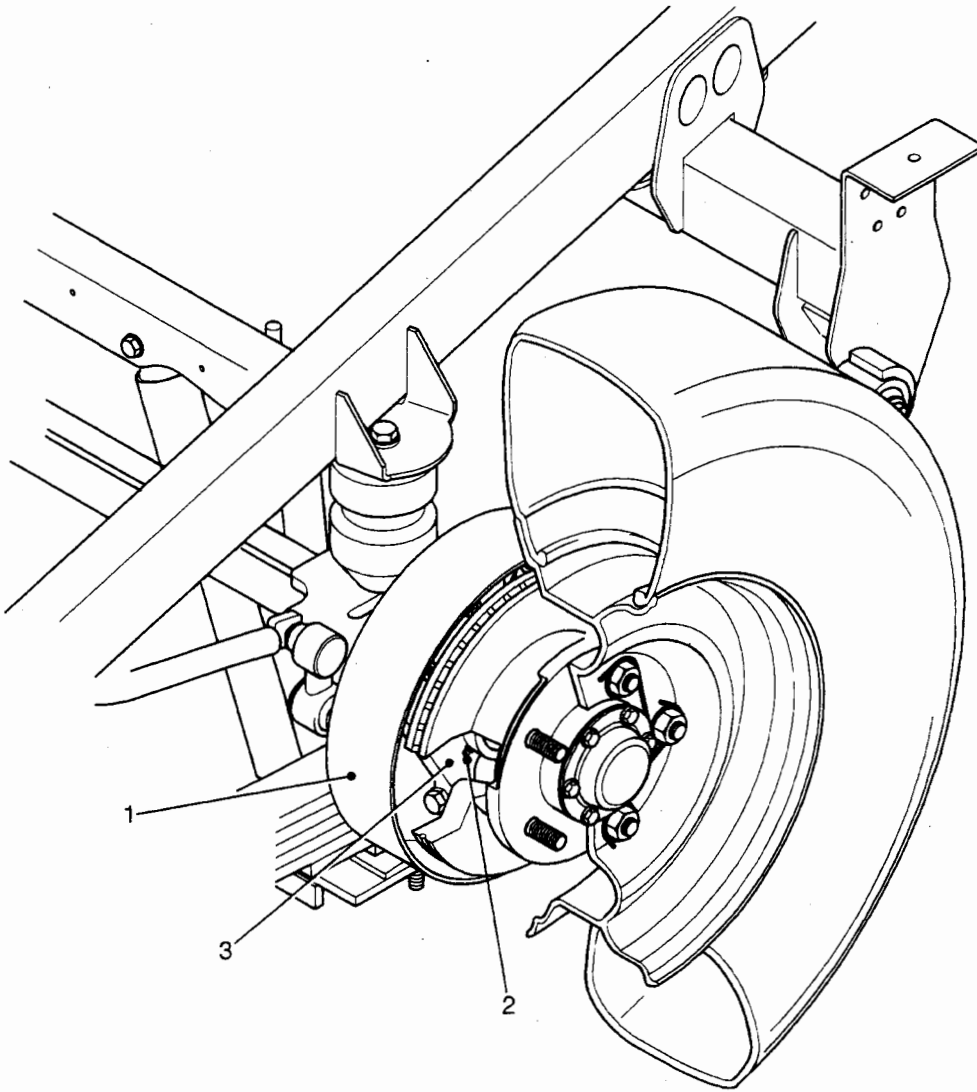

TRL/068

- | | | | |
|---|-------------------------|---|-----------|
| 1 | Stone guard | 3 | Pivot hub |
| 2 | Pivot hub grease nipple | | |

Fig 5 Pivot hub lubrication

MASTER CYLINDER COVER

CAUTION

EQUIPMENT DAMAGE. The space available when removing the master cylinder cover spring clip is limited. Apply caution when using hand tools to prevent damage to the master cylinder and fittings.

22 The master cylinder cover (Fig 2 (2)) is secured in position using a single restraining pin. When serviceable the pin engages with a spring clip welded to the overrun assembly bracket. If the spring clip fails and requires a replacement proceed as follows:

- 22.1 Remove the cover as detailed in Cat 201, Chap 3.
- 22.2 Using a suitable cold chisel remove the existing spring clip from the bracket.
- 22.3 Using a suitable hand file dress the area of the spring clip to remove any residual weld material. The area must be even and uniform in thickness.
- 22.4 Patch paint the area as required. Allow the paint to dry.
- 22.5 Position a replacement spring clip into the opening in the cover. The replacement spring clip will clip into position without the need for additional material to be removed.
- 22.6 Refit the cover.



CHAPTER 6
JOCKEY WHEEL AND REAR SUPPORTS
CONTENTS

Para

- Jockey wheel assembly
- 1 Removal
- 2 Refitting
- Jockey wheel pivot
- 3 Removal
- 4 Refitting
- Rear support stand
- 5 Removal
- 6 Refitting
- Rear tow hitch
- 7 Replacement

Fig

Page

1	Jockey wheel assembly	2
2	Rear support stand	4

JOCKEY WHEEL ASSEMBLY

Removal

- 1 To remove the jockey wheel assembly, proceed as follows:
 - 1.1 Ensure the towing frame is supported on a vehicle stand.
 - 1.2 Remove the two mounting bolts (Fig 1 (4)), nuts and washers and remove the jockey wheel assembly (2).

Refitting

- 2 To refit the jockey wheel assembly, proceed as follows:
 - 2.1 Supporting the jockey wheel, refit the two mounting bolts (4), nuts and washers.
 - 2.2 Tighten to 187 Nm (138 lbf ft).
 - 2.3 Remove the vehicle stand and lower the trailer onto the jockey wheel.

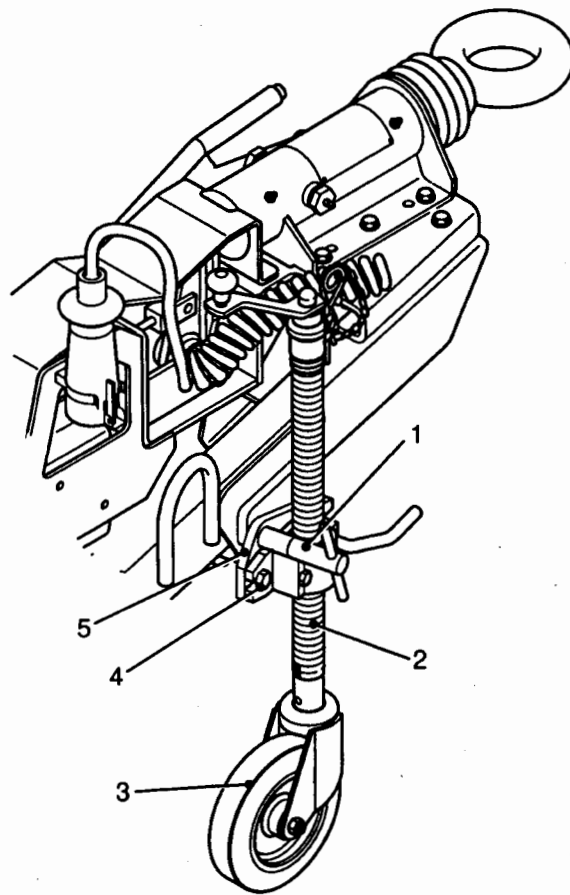

TRL/043

- | | | | |
|---|-----------------------|---|--------------------|
| 1 | Locking pin | 4 | Mounting bolt |
| 2 | Jockey wheel assembly | 5 | Jockey wheel pivot |
| 3 | Jockey wheel | | |

Fig 1 Jockey wheel assembly

JOCKEY WHEEL PIVOT

Removal

- 3 To remove the jockey wheel pivot (Fig 1 (5)), proceed as follows:
 - 3.1 Remove the jockey wheel as detailed in Para 1.
 - 3.2 Remove the single nyloc nut complete with plain washer and nylon washer securing the pivot in the welded swivel bracket. Discard the nyloc nut. Note the orientation of the washers for refitting purposes.
 - 3.3 With the pivot removed check for signs of excessive wear to the swivel bracket.

Refitting

- 4 To refit the jockey wheel pivot proceed as follows:
 - 4.1 Refit the pivot to the swivel bracket using the correct washer orientation.
 - 4.2 Fully tighten the replacement nyloc nut and then back off 1/4 of a complete turn. Ensure that the pivot rotates freely and the locking plunger engages fully with the two holes in the swivel bracket.
 - 4.3 Apply grease to the pivot as detailed in Cat 601.
 - 4.4 Refit the jockey wheel as detailed in Para 2.

REAR SUPPORT STAND

Removal

- 5 To remove a rear support stand, proceed as follows:
 - 5.1 Ensure the handbrake is applied.
 - 5.2 Lower and secure the support stand opposite to the one being removed as detailed in Cat 201, Chap 2.
 - 5.3 Remove the two mounting bolts (Fig 2 (3)), nuts and washers and remove the support stand (1).

Refitting

- 6 To refit a rear support stand, proceed as follows:
 - 6.1 Refit the support stand using the two bolts, nuts and washers. Tighten to 187 Nm (138 lbf ft).
 - 6.2 Raise the other support stand.

REAR TOW HITCH

Replacement

- 7 To replace the rear tow hitch, proceed as follows:
 - 7.1 Ensure the handbrake is applied.

- 7.2 Lower the rear support stands.
- 7.3 Supporting the rear tow hitch, remove the four mounting bolts, nuts and washers.
- 7.4 Remove the tow hitch.
- 7.5 Locate the tow hitch and hold in position using one bolt, nut and washer.
- 7.6 Refit the other three bolts, nuts and washers.
- 7.7 Tighten all bolts to 44 Nm (32 lbf ft).
- 7.8 Raise the two rear support stands.

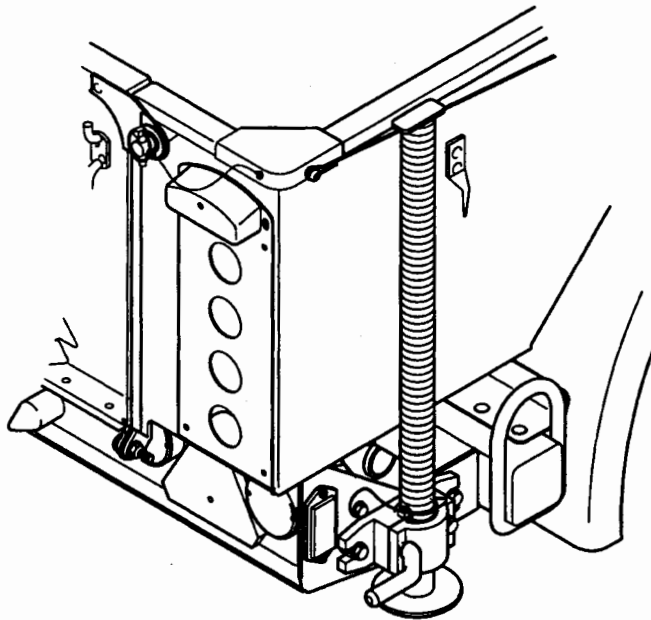

TRL/044

- 1 Rear support stand 2 Leg clamp 3 Mounting bolt

Fig 2 Rear support stand

CHAPTER 7
ELECTRICS
CONTENTS

Para

- Stop/tail, side, turn and fog light assemblies
- 1 Removal
- 2 Refitting
- Convoy light assembly
- 3 Removal
- 4 Refitting
- Number plate light assembly
- 5 Removal
- 6 Refitting
- Wiring harness
- 7 Replacement

Fig

Page

1	Light assembly.....	2
2	Convoy light assembly.....	4
3	Number plate light assembly	6

STOP/TAIL, SIDE, TURN AND FOG LIGHT ASSEMBLIES

Removal

- 1 To remove the light assemblies, (Fig 1 (8)), proceed as follows:
 - 1.1 Ensure the handbrake is applied, and the trailer electrics are disconnected from the prime mover.
 - 1.2 Disconnect the branch connector (2) from the rear of the lamp holder (1) to be removed.
 - 1.3 Remove the lens (6).
 - 1.4 Remove the two nuts (3) and washers (4) from the rear of the chassis, whilst supporting the plinth (7).
 - 1.5 Remove the plinth from the trailer.

Refitting

- 2 To refit the light assembly, proceed as follows:
 - 2.1 Supporting the plinth (7) in position refit the two nuts (3) and washers (4).
 - 2.2 Reconnect the branch connector (2) to the lamp holder (1).
 - 2.3 Refit the lens (6).
 - 2.4 Connect the trailer lighting cable to a suitable prime mover.
 - 2.5 Test the light assembly.

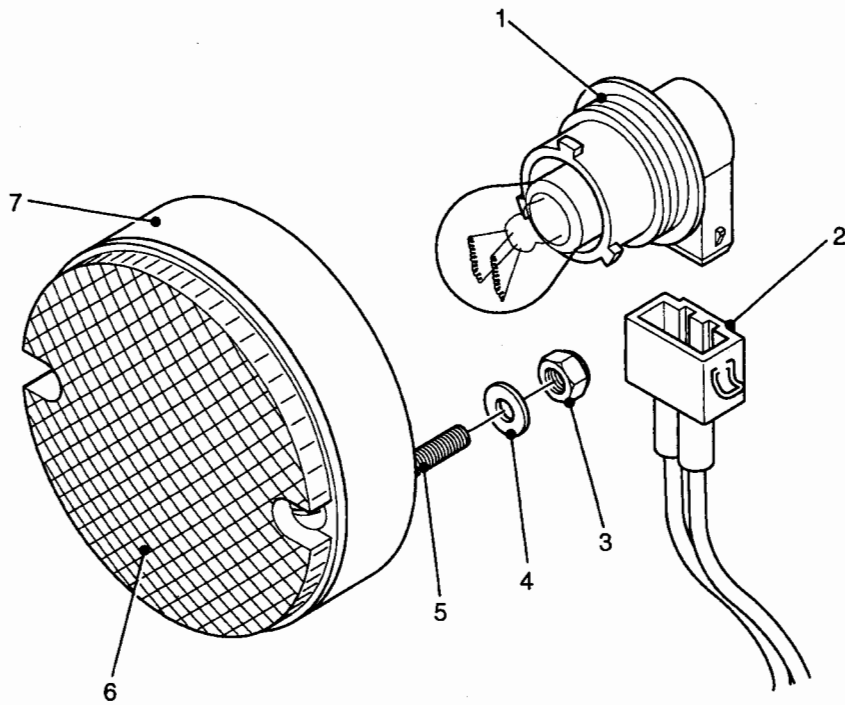

TRL/042

- | | | | |
|---|------------------|---|----------------|
| 1 | Lamp holder | 5 | Mounting screw |
| 2 | Branch connector | 6 | Lens |
| 3 | Nut | 7 | Plinth |
| 4 | Washer | | |

Fig 1 Light assembly

CONVOY LIGHT ASSEMBLY

Removal

- 3 To remove the convoy light assembly (Fig 2), proceed as follows:
 - 3.1 Ensure the handbrake is applied and the trailer electrics are disconnected from the prime mover.
 - 3.2 Disconnect the harness branch connector (8) from the lamp holder.
 - 3.3 Remove mounting plate (9).
 - 3.4 Remove the two nuts (7) and washers (6) being careful not to drop the lens plate (4).
 - 3.5 Collect the distance pieces (5).
 - 3.6 Remove the light body (2) from its mounting.

Refitting

- 4 To refit the convoy light assembly, proceed as follows:
 - 4.1 Locate the mounting screw (1).
 - 4.2 Refit the light body (2) onto the mounting screws and support in position.
 - 4.3 Refit distance pieces (5) onto the mounting screws and support in position.
 - 4.4 Refit the lens plate (4) and secure in position by two nuts (7) and washers (6).
 - 4.5 Refit the mounting plate (9) to the chassis.
 - 4.6 Refit the harness branch connector (8).
 - 4.7 Connect the trailer lighting cable to a suitable prime mover.
 - 4.8 Test the light assembly.

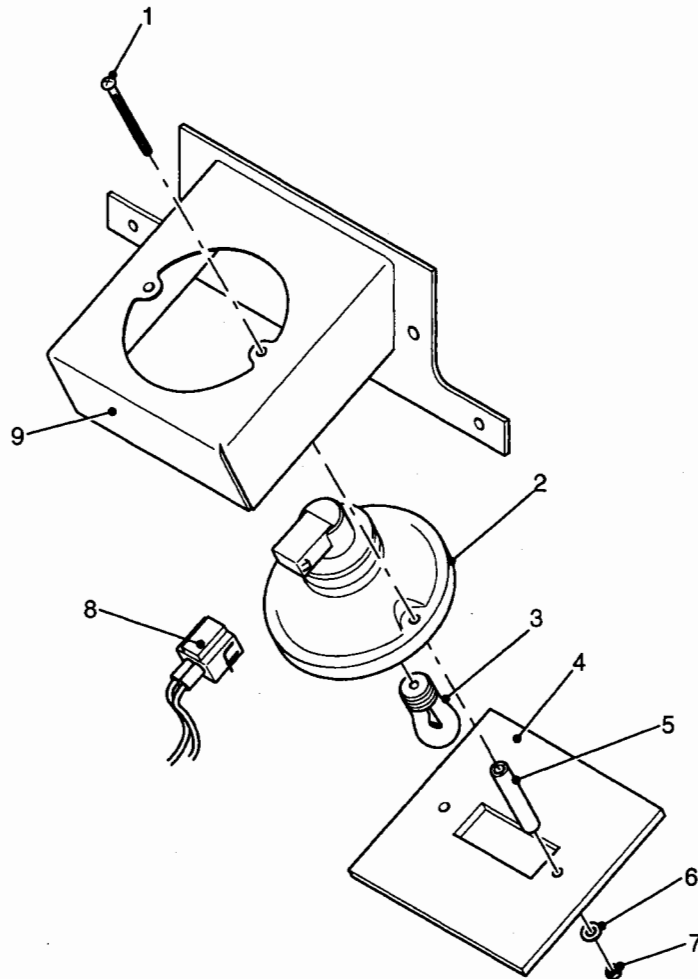

TRL/040

- | | | | |
|---|----------------|---|--------------------------|
| 1 | Mounting screw | 6 | Washer |
| 2 | Light body | 7 | Securing nut |
| 3 | Lamp | 8 | Harness branch connector |
| 4 | Lens plate | 9 | Mounting plate |
| 5 | Distance piece | | |

Fig 2 Convoy light assembly

NUMBER PLATE LIGHT ASSEMBLY

Removal

- 5 To remove the number plate light assembly, proceed as follows:
 - 5.1 Remove the bolt (Fig 3(5)), lock washer (6) and flat washer (7).
 - 5.2 Remove the plug from the lamp holder.
 - 5.3 Remove the two bolts, securing the number plate light, from the rear of the number plate (8).
 - 5.4 Remove the light assembly from the number plate.

Refitting

- 6 To refit the number plate light assembly, proceed as follows:
 - 6.1 Refit the light assembly into the recess in the number plate.
 - 6.2 Refit the two securing bolts.
 - 6.3 Refit the plug to the lamp holder.
 - 6.4 Refit the bolt (5), lock washer (6) and flat washer (7).
 - 6.5 Connect the trailer lighting cable to a suitable prime mover.
 - 6.6 Test the light assembly.

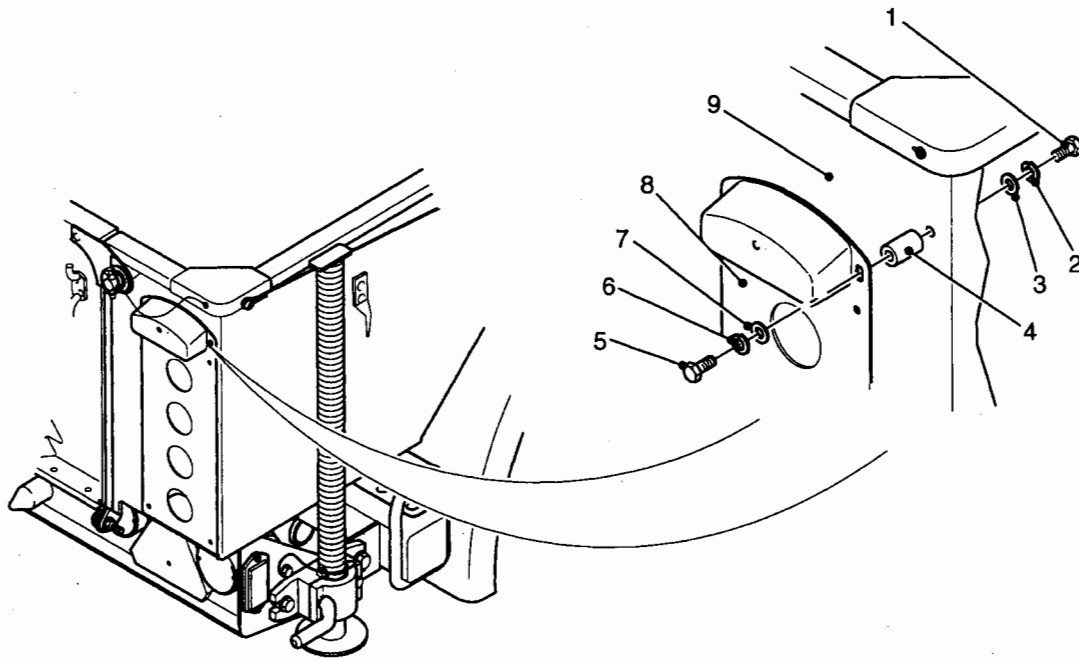

TRL/046

- | | | | |
|---|----------------------------|---|--------------|
| 1 | Body mounting bolt | 6 | Lock washer |
| 2 | Lock washer | 7 | Flat washer |
| 3 | Flat washer | 8 | Number plate |
| 4 | Anti-vibration bush | 9 | Trailer body |
| 5 | Number plate mounting bolt | | |

Fig 3 Number plate light assembly

WIRING HARNESS

Replacement

- 7 To replace the harness, proceed as follows:
 - 7.1 Ensure the handbrake is applied.
 - 7.2 Remove the cable P clips from the draw frame and chassis.
 - 7.3 Remove all harness branch connectors from the light assemblies.
 - 7.4 Remove the cable ties securing the harness to the chassis, noting the route.
 - 7.5 Feed the number plate section of the harness through the chassis.
 - 7.6 Remove the securing nuts and washers holding the junction box to the chassis.
 - 7.7 Remove the harness.
 - 7.8 Lay the new harness under the trailer.
 - 7.9 Refit the junction box to the chassis.
 - 7.10 Refit the harness to the chassis as noted in Para 7.4. Refit replacement cable ties in all locations.
 - 7.11 Pass the number plate harness through the chassis.
 - 7.12 Reconnect the harness branch connectors to the light assemblies.
 - 7.13 Refit the P clips to the draw frame and chassis.
 - 7.14 Connect the trailer lighting cable to a suitable prime mover.
 - 7.15 Test the lights.



CHAPTER 8
AXLE ASSEMBLY
CONTENTS

Para

- 1 Introduction
Axle assembly
- 2 Removal
- 3 Refitting

Fig

Page

1	Axle assembly	3
2	Flexible brake pipe	4

INTRODUCTION

- 1 The removal of the axle assembly is detailed in this Category, but it is to be undertaken at Level 3.

AXLE ASSEMBLY

Removal

- 2 To remove the axle assembly, proceed as follows:
 - 2.1 Raise the trailer onto suitable stands.
 - 2.2 Using suitable hydraulic jacks, just support the weight of the axle.
 - 2.3 Remove each road wheel as detailed in Cat 201, Chap 3.
 - 2.4 Remove the axle check straps (Fig 1 (1)).
 - 2.5 Remove the anti-roll bar (13) from the axle as detailed in Chap 4.
 - 2.6 Remove the lower shock absorber mounting, nuts (8), washers (9), stepped washers (11) and bush (10).
 - 2.7 Ease the shock absorber (14) out of the clamping plate (11).
 - 2.8 Remove the handbrake cables from the caliper as detailed in Chap 5.
 - 2.9 Using a suitable container for spillage, remove the hydraulic flexible brake pipe (Fig 2 (2)) at the hub back plate brake pipe connection (1).
 - 2.10 Remove the studs and U bolt nuts (Fig 1 (7)) and lock washers (6), and remove the clamping plate.
 - 2.11 Remove the studs (5) (with flat washers uppermost) and U bolts.
 - 2.12 Remove the front spring hanger bolts (2) complete with nuts and washers, and lower the springs to the floor.
 - 2.13 Remove the axle assembly.

Refitting

- 3 To refit the axle assembly, proceed as follows:
 - 3.1 Locate the axle under the trailer and place on hydraulic jacks.
 - 3.2 Jack the axle up clear of the springs.
 - 3.3 Refit each spring back onto its hanger using bolts (2), nuts and washers.
 - 3.4 Refit the U bolts and studs (5) (with flat washers uppermost).
 - 3.5 Lower the axle onto the springs.
 - 3.6 Refit the clamping plate (11) and secure using the nuts (7) and lock washers (6). Tighten to 99 Nm (73 lbf ft) in the three stages detailed in Chap 4.
 - 3.7 Refit the anti-roll bar (12) as detailed in Chap 4.
 - 3.8 Ease the shock absorber (14) into the hole in the clamping plate (12).
 - 3.9 Refit the stepped washer (11), bush (10), washer (9) and nut (8). Tighten to 33 Nm (24 lbf ft).
 - 3.10 Refit the hydraulic pipe.
 - 3.11 Refit the handbrake cables as detailed in Chap 5.
 - 3.12 Refit the axle check strap (1).
 - 3.13 Bleed the brakes as detailed in Chap 5.
 - 3.14 Refit the road wheels as detailed in Cat 201, Chap 3.
 - 3.15 Remove the stands and jacks from the trailer.
 - 3.16 Road test the vehicle as detailed in Cat 532.

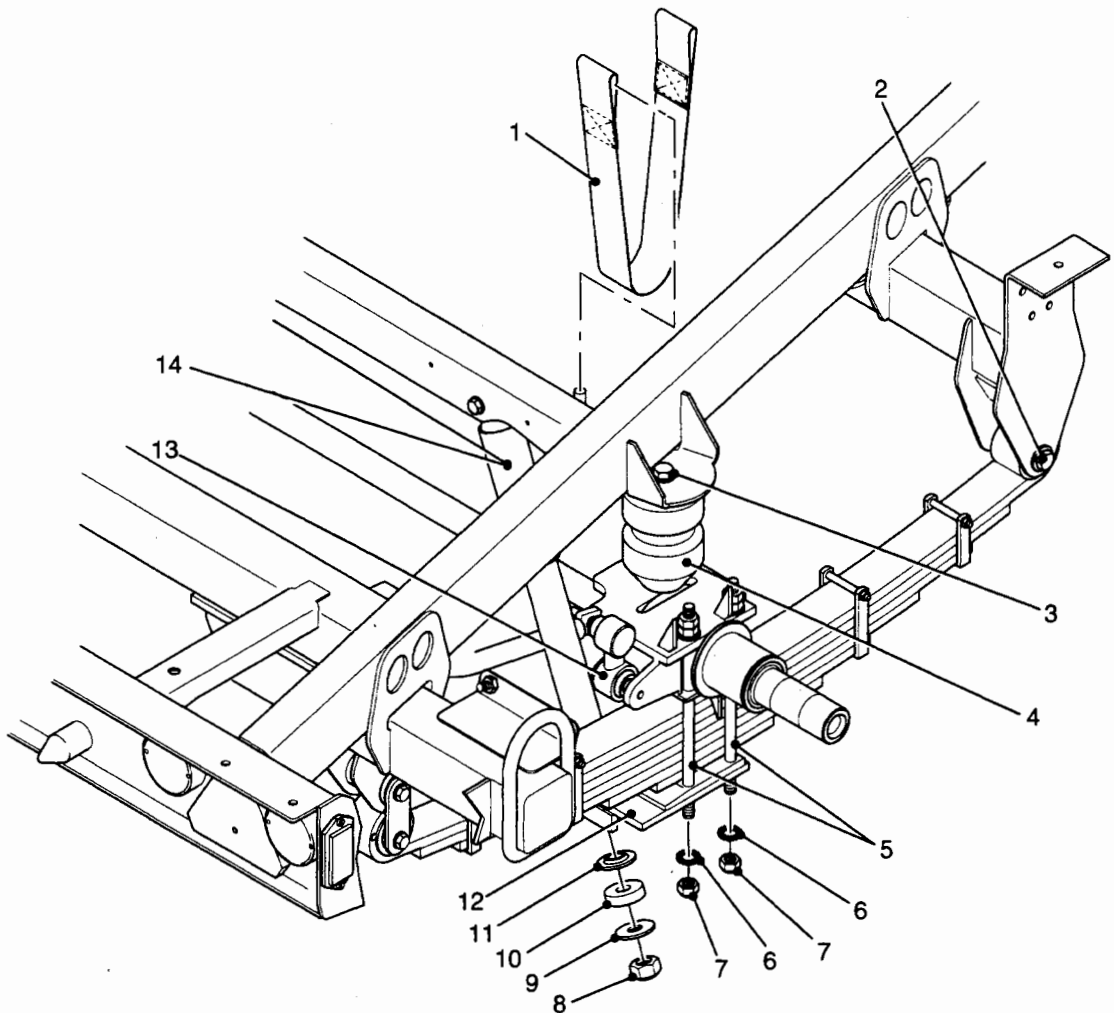

HUB REMOVED FOR CLARITY

TRL/047

- | | | | |
|---|--------------------|----|--------------------|
| 1 | Axle check strap | 8 | Shock absorber nut |
| 2 | Spring hanger bolt | 9 | Flat washer |
| 3 | Bolt | 10 | Bush |
| 4 | Aeon spring | 11 | Stepped washer |
| 5 | Axle studs | 12 | Clamping plate |
| 6 | Lock washer | 13 | Anti-roll bar |
| 7 | Axle stud nut | 14 | Shock absorber |

Fig 1 Axle assembly

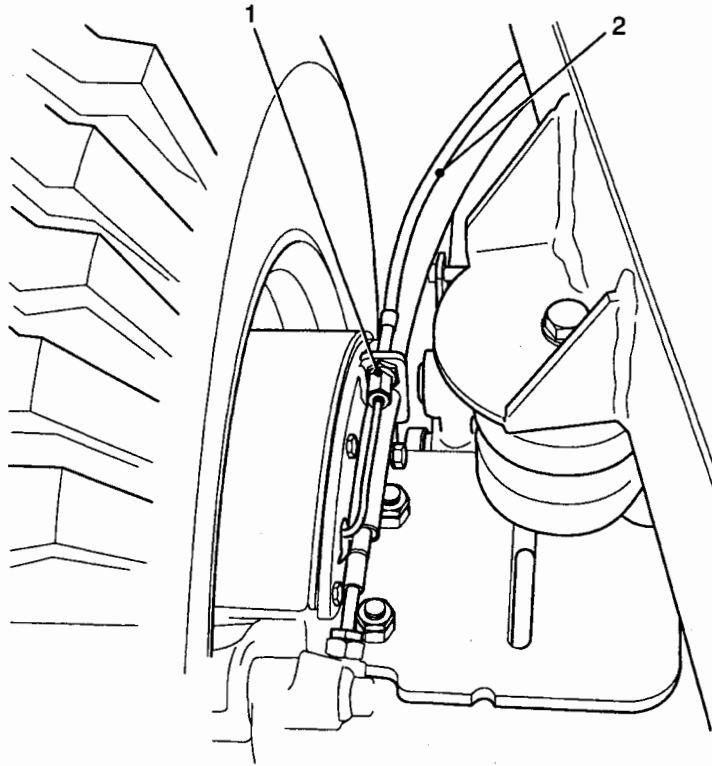

TRL/052

- 1 Brake pipe connection 2 Flexible brake pipe

Fig 2 Flexible brake pipe

COMMENT(S) ON AESP*

To: DCCS
BFPO 794

From:
.....
.....
.....

Sender's Reference	BIN Number	Date
AESP* Title:		
Chapter(s)/Instruction	Page(s)/Paragraph(s)	
If you require more space, please use the reverse of this form or a separate piece of paper. Comment(s):		

Signed: Telephone No.:
Name (Capitals): Rank/Grade: Date:
X.....

FOR AESP* SPONSOR USE ONLY

To: From:
.....
.....
.....

Thank you for commenting on AESP*:
Your reference: Dated:

Action is being taken to:	Tick	Tick
Issue a revised/amended AESP*		Under investigation
Incorporate comment(s) in future amendments		No action required
Remarks		

Signed: Telephone No.:
Name (Capitals): Rank/Grade: Date:

* AESP or EMER

