

**O-155-15**

**REGISTERED DESIGNS ACT 1949 (AS AMENDED)**

**IN THE MATTER OF REGISTERED DESIGN NO. 4033752  
IN THE NAME OF TRUSCOTT TERRACE HOLDINGS LLC  
IN RESPECT OF THE FOLLOWING DESIGN:**



**AND  
A REQUEST TO INVALIDATE (NO. 03/14)  
BY CATACLEAN GLOBAL LIMITED**

## THE BACKGROUND AND PLEADINGS

1. The registered design the subject of these proceedings was filed by Truscott Terrace Holdings LLC (the proprietor) on 9 January 2014 with its certificate of registration being granted on 17 January 2014. The design is described as a “bottle for general use” and is depicted below:



2. Further representations of the design were provided with the application for registration; these will be depicted later.

3. On 12 February 2014 Cataclean Global Limited (the applicant) requested the invalidation of the design under section 1B<sup>1</sup> of the Registered Designs Act 1949 (the Act), which relates to the requirement that designs must be novel in comparison to others that have been made available to the public. The design which, it is claimed, destroys the novelty of the registered design is “a bottle on general sale”. An example of which has been provided as follows:

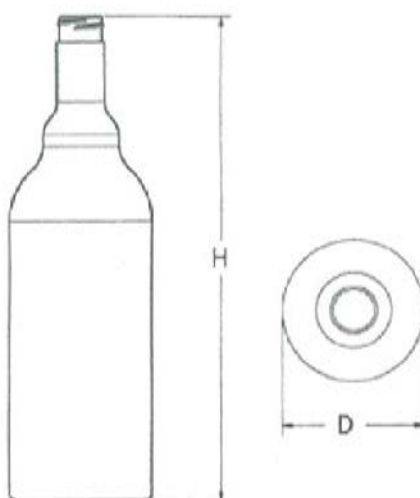

---

<sup>1</sup> This is relevant in invalidation proceedings due to the provisions of IZA which gives the grounds for invalidation of a registered design.

4. It is stated that the earlier design has been in the public domain since 2006 and has been used by the applicant since 2010.

5. The proprietor filed a counterstatement denying the claims. It maintains that the design referenced in the application for invalidation is an 'industry stock' bottle known as the 'Austin Round', whilst the bottle the subject of its design registration is the result of a new moulding process, proprietary design and unique characteristics not present in the stock bottle.

6. The applicant filed evidence with its statement of case<sup>2</sup> and subsequently filed written submissions; the proprietor filed evidence. A hearing took place before me on 12 March 2015 at which Mr Gordon Gannon of Truscott represented the proprietor and Mr Simon Pine of Cataclean's legal department represented the applicant.

### **The applicant's submissions and evidence**

7. The applicant filed submissions on 9 June 2014. The relevant points are as follows:

- The bottle design has been in existence since 2006.
- The proprietor has acknowledged that it was in existence in England in 2011.
- The registered bottle design is "actually nothing more than an insignificant, functional modification to an already pre-existing design".
- The applicant has used the bottle design continuously since it first imported the bottle to the United States in 2011.
- To date, the applicant has sold well over 100,000 units of CATACLEAN in the US in the bottle to which the registered proprietor claims rights.
- The proprietor has never used the bottle design in commerce to sell a real product to an actual customer.

### **The proprietor's evidence**

*Affidavit of Gregory P Gannon*

8. Mr Gannon states that he is the designer and developer of the bottle the subject of the design registration and is a member and shareholder of the proprietor.

9. The main points arising from his statement are as follows:

- On 1<sup>st</sup> July 2010 Mr Gannon contacted a manufacturer in China requesting information for the development and manufacture of a proprietary bottle.

---

<sup>2</sup> See rule 21(1)(a), *The Registered Designs Rules 2006*

- On 5<sup>th</sup> July 2010 the Chinese manufacturer provided an example of a stock bottle, the Austin Round (exhibit GPG002).
- On 5<sup>th</sup> July Mr Gannon declined the Austin Round stating, “The bottle is too small and does not meet the specification of the schematic that was attached to the original enquiry.” (exhibit GPG003).

10. In his affidavit Mr Gannon stated:

*“14. I state with first-hand knowledge that when I designed the new bottle, I specifically wanted the neck portion to have a subtle “bump out”, sharper lines and a sloped transition instead of modular curves and rounded transitions as depicted in a side by side comparison attached as Exhibit GPG004<sup>3</sup>.”*

11. At paragraph 15 of his affidavit, Mr Gannon refers to the response to this email which was dated 7 July 2010:

*“I was advised by the Asia manufacturer that they could in fact “open a mold” which means that they would custom make a mold to meet my design specifications. This was a response to the request for design and thread confirmation as well as a request to remove an additional “bump out”. Upon completion of the custom mold, I would be sent 5 (five) each samples for review and approval.”*

## **The legal background**

12. Section 1B of the Act reads:

“(1) A design shall be protected by a right in a registered design to the extent that the design is new and has individual character.

(2) For the purposes of subsection (1) above, a design is new if no identical design whose features differ only in immaterial details has been made available to the public before the relevant date.

(3) For the purposes of subsection (1) above, a design has individual character if the overall impression it produces on the informed user differs from the overall impression produced on such a user by any design which has been made available to the public before the relevant date.

(4) In determining the extent to which a design has individual character, the degree of freedom of the author in creating the design shall be taken into consideration.

(5) For the purposes of this section, a design has been made available to the public before the relevant date if-

---

<sup>3</sup> Attached as Annex I of this decision

(a) it has been published (whether following registration or otherwise), exhibited, used in trade or otherwise disclosed before that date; and

(b) the disclosure does not fall within subsection (6) below.

(6) A disclosure falls within this subsection if-

(a) it could not reasonably have become known before the relevant date in the normal course of business to persons carrying on business in the European Economic Area and specialising in the sector concerned;

(b) it was made to a person other than the designer, or any successor in title of his, under condition of confidentiality (whether express or implied);

(c) it was made by the designer, or any successor in title of his, during the period of 12 months immediately preceding the relevant date;

(d) it was made by a person other than the designer, or any successor in title of his, during the period of 12 months immediately preceding the relevant date in consequence of information provided or other action taken by the designer or any successor in title of his; or

(e) it was made during the 12 months immediately preceding the relevant date as a consequence of an abuse in relation to the designer or any successor in title of his.

(7) In subsections (2), (3), (5) and (6) above “the relevant date” means the date on which the application for the registration of the design was made or is treated by virtue of section 3B(2), (3) or (5) or 14(2) of this Act as having been made.

(8)...

13. The relevant case law was conveniently set out by Birss J. in paragraphs 31 to 59 of his judgment in *Samsung v Apple*<sup>4</sup>. The most relevant parts are as follows:

**“The informed user**

33. The designs are assessed from the perspective of the informed user. The identity and attributes of the informed user have been discussed by the *Court of Justice of the European Union in PepsiCo v Grupo Promer (C-281/10P) [2012] FSR 5* at paragraphs 53 to 59 and also in *Grupo Promer v OHIM [2010] ECDR 7*, (in the General Court from which

---

<sup>4</sup> [2012] EWHC 1882 (Pat)

PepsiCo was an appeal) and in *Shenzhen Taiden v OHIM*, case T-153/08, 22 June 2010.

34. Samsung submitted that the following summary characterises the informed user. I accept it and have added cross-references to the cases mentioned:

i) He (or she) is a user of the product in which the design is intended to be incorporated, not a designer, technical expert, manufacturer or seller (*PepsiCo* paragraph 54 referring to *Grupo Promer* paragraph 62; *Shenzen* paragraph 46).

ii) However, unlike the average consumer of trade mark law, he is particularly observant (*PepsiCo* paragraph 53);

iii) He has knowledge of the design corpus and of the design features normally included in the designs existing in the sector concerned (*PepsiCo* paragraph 59 and also paragraph 54 referring to *Grupo Promer* paragraph 62);

iv) He is interested in the products concerned and shows a relatively high degree of attention when he uses them (*PepsiCo* paragraph 59);

v) He conducts a direct comparison of the designs in issue unless there are specific circumstances or the devices have certain characteristics which make it impractical or uncommon to do so (*PepsiCo* paragraph 55).

35. I would add that the informed user neither (a) merely perceives the designs as a whole and does not analyse details, nor (b) observes in detail minimal differences which may exist (*PepsiCo* paragraph 59).

### **Design freedom**

40. In *Grupo Promer* the General Court addressed design freedom in paragraphs 67-70. In Dyson Arnold J. summarised that passage from *Grupo Promer* as follows:

“design freedom may be constrained by (i) the technical function of the product or an element thereof, (ii) the need to incorporate features common to such products and/or (iii) economic considerations (e. g. the need for the item to be inexpensive).”

### **Effect of differences between the registered design and the design corpus**

51. Apple drew my attention to paragraph 74 of the judgment of the General Court in *Grupo Promer* in which the Court agreed with the ruling of the Board of Appeal that:

“as regards the assessment of the overall impression produced by the designs at issue on the informed user, the latter will automatically disregard elements ‘that are totally banal and common to all examples of the type of product in issue’ and will concentrate on features ‘that are arbitrary or different from the norm’.”

52. Apple submitted that this showed that a design feature need not be unique to be relevant. It is only disregarded if it is totally banal. Thus, Apple submitted, for a feature to be relevant it merely needs to differ from the norm and by logical extension, the greater the difference from the norm, the more weight to be attached to it. The point of this submission is to challenge the manner in which Apple contended Samsung was advancing its case. I do not think Apple's characterisation of Samsung's case was entirely accurate but in any case I accept Apple's submission on the law at least as follows. The degree to which a feature is common in the design corpus is a relevant consideration. At one extreme will be a unique feature not in the prior art at all, at the other extreme will be a banal feature found in every example of the type. In between there will be features which are fairly common but not ubiquitous or quite rare but not unheard of. These considerations go to the weight to be attached to the feature, always bearing in mind that the issue is all about what the items look like and that the appearance of features falling within a given descriptive phrase may well vary.

### **The correct approach, overall**

57. The point of design protection must be to reward and encourage good product design by protecting the skill, creativity and labour of product designers. This effort is different from the work of artists. The difference between a work of art and a work of design is that design is concerned with both form and function. However design law is not seeking to reward advances in function. That is the sphere of patents. Function imposes constraints on a designer's freedom which do not apply to an artist. Things which look the same because they do the same thing are not examples of infringement of design right.

58. How similar does the alleged infringement have to be to infringe? Community design rights are not simply concerned with anti-counterfeiting. One could imagine a design registration system which was intended only to allow for protection against counterfeits. In that system only identical or nearly identical products would infringe. The test of “different overall impression” is clearly wider than that. The scope of protection of a Community registered design clearly can include products which can be distinguished to some degree from the registration. On the other hand the fact that the informed user is particularly observant and the fact that designs will often be considered side by side are both clearly intended to narrow the scope of design protection. Although no doubt minute scrutiny by the informed user is not the right approach, attention to detail matters.”

As can be seen from paragraph 58 above, the Act requires a design to be both new and to have individual character. A design is new if it differs in material details from previous designs. Thus a design may be new because it differs in material details compared to previous designs, but may still fail to create a different overall impression compared to previous designs and therefore to lack the necessary individual character.

### **The design corpus and prior art**

14. Throughout the proceedings the applicant has referred to the prior art as both the 'austin round' and the 'cataclean bottle'. At the hearing I asked Mr Pine to confirm whether there were any differences between these two bottles. He stated that they are one and the same. I will refer to the prior art as the 'Austin Round' as the applicant claims that this bottle is used by numerous undertakings in addition to its own use. No evidence was filed by either party that indicates there are any other designs which contribute to the overall design corpus.

15. According to section 1B(7) of the Act, prior art can only be relied upon to invalidate a registered design if it has been disclosed to the public prior to the application date of the registered design being attacked, unless the exceptions in subsection (6) apply. This means that the relevant date for my assessment is 9 January 2014. Any prior art must have been made available to the public prior to this date.

16. In its submissions dated 6 June 2014 the applicant states:

*"The CATACLEAN [Austin Round] bottle is a generic, functional design. The bottle design is comprised of a cylinder with an elongated neck used to pour the fuel additive into a gas tank. The bottle design has been used in the automotive industry since at least as early as 2006."*

17. This statement has not been challenged. At the hearing I asked Mr Gannon to provide me with a date at which he was aware that the 'Austin Round' was available. He declined to provide one. In evidence he has provided there is an email dated July 2010 in which the 'Austin Round' bottle was offered to him by an Asian manufacturer. This clearly shows that the prior art, the 'Austin Round', was available before the relevant date.

18. At the hearing, Mr Gannon stated that the registered proprietor has been using its own design, subject of the contested registered design, since 1 March 2011. This may have offered an alternative ground of invalidation (on the basis of self-disclosure), however, no such ground was included in the applicant's pleadings, nor was anything provided in evidence which would support the statement. In fact, in its submissions the applicant states:

*"The proprietor has never used the bottle design in commerce to sell a real product to an actual customer."*

19. Mr Pine maintained this view on behalf of the applicant throughout the hearing. Consequently, if the applicant does not even accept that the registered design was self-disclosed then I need give this matter no further consideration.



## The informed user

20. The informed user is not a casual user but must instead be deemed to be a knowledgeable/particularly observant user of bottles and will possess those characteristics (knowledge/experience) set out in the preceding case-law.

## Design freedom

21. At the hearing, the applicant stated that the 'Austin Round' neck is the shape necessary to enable a fuel additive to be added to a fuel tank. Whilst it is possible that the proprietor's bottle may have the same purpose, I note that in Gregory Gannon's witness statement he says:

*"11...I sent a request to a manufacturer in Asia to begin the process of developing a proprietary, non-stock, custom bottle with a 22/400 closure thread, I specifically requested this thread count as a means to capture the broadest potential market/applications possible due to neck size."*

22. Consequently, since the registered design is not limited to a specific purpose, I will compare the bottles without reference to a specific use. It is possible for bottles to come in many shapes and sizes, though they will share particular characteristics. There must be a hollow portion in which the contents are stored and a neck and opening to enable the contents to be poured. Commercially, it would be logical to assume that there are a number of standard shapes and sizes available in order to keep costs down but that there is still a degree of design freedom.

## Comparison of designs

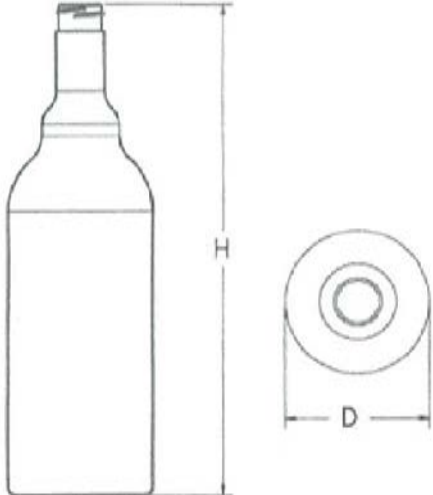
The registered design	The prior art
 A photograph showing a tall, slender, clear plastic bottle with a long neck. To the right of the bottle is a close-up photograph of the bottle's cap, which is circular and has some embossed text and a logo.	 A technical line drawing of a bottle. The drawing shows a side view of the bottle with a vertical dimension line labeled 'H' indicating the height. To the right of the side view is a top-down view of the bottle's neck, showing a circular shape with a smaller circle inside, and a horizontal dimension line labeled 'D' indicating the diameter.

23. These designs are not identical, however, designs can be considered identical where the differences between them are immaterial. Mr Pine submitted that the differences between the 'Austin Round' and the registered design were insignificant being nothing more than functional modifications to "an already pre-existing design". The 'Austin Round' has a proportionately shorter body in relation to the overall height of the bottle, has a shorter, wider neck and a different profile where the neck of the bottle joins the body. The applicant has not put forward any supporting information to indicate why any differences are purely functional and I am not persuaded that this is the case.

24. In terms of its overall impression, the prior art is a bottle with a fairly short neck, compared with its overall height and a convex collar where the neck joins the body of the bottle giving a slightly unusual profile with an additional 'bump'. The shoulders of the bottle are rounded, giving the bottle overall a rounded, curved shape.

25. The overall impression of the registered design is of a bottle with a long, slim neck in relation to its overall height. The straight sided body of the bottle makes up a significant proportion of the overall design. Where the neck joins the body of the bottle there is a double collar which creates a stepped effect. The shoulders of the bottle slope to the edge of the body in a straight line giving a sharp edge. Overall the bottle has a fairly angular profile.

26. The relative proportion of the bodies of both bottles varies greatly, as do the respective lengths of the neck portions and the profile of the shoulders where the necks join the bodies of the bottles. After considering the relevant factors, I am satisfied that the differences I have identified mean that the overall impressions of these designs differ from each other.

27. I hold that the registered design is valid and may remain on the register.

### **Costs**

28. Truscott Terrace Holdings LLC has been successful and is entitled to a contribution towards its costs. At the hearing I asked the parties to make submissions on costs. The applicant asks for actual costs amounting to £8342. The proprietor asks for costs totalling £5627.

29. Throughout these proceedings both parties have filed numerous documents relating to matters extraneous to this case<sup>5</sup>. The registrar's powers are set out in Rule 22 of the Registered Designs Rules 2006 as follows:

"The registrar may, in any proceedings before him under the Act, award to any party by order such costs as he considers reasonable and direct how and by what parties they are to be paid."

30. Therefore costs may be awarded only to cover the cost of bringing these proceedings and are normally awarded on a contribution (as opposed to compensatory) basis. Neither side has given any indication as to why an award of actual costs or costs above the normal scale would be appropriate. I see no reason

---

<sup>5</sup> For the most part these consist of documents referring to cases completed or still extant in the US which are not related to these proceedings.

to depart from the standard approach here. I award costs to Truscott Terrace Holdings LLC on the following basis, bearing in mind that the registered proprietor attended by telephone:

Preparing a statement and considering the other side's statement	£300
Filing evidence and considering the other sides' submissions	£600
Preparation for and attendance at a hearing	£300
<b>Total</b>	<b>£1200</b>

31. Subject to appeal, the above sum should be paid by Cataclean Global Limited within 14 days of the end of the period allowed for appeal or, if there is an unsuccessful appeal, within 14 days of the conclusion of those proceedings.

**Dated this 9th day of April 2015**

**Al Skilton  
For the Registrar,  
The Comptroller-General**

Annex 1

Austin Round VS Truscott Terrace Holdings LLC Bottle Design

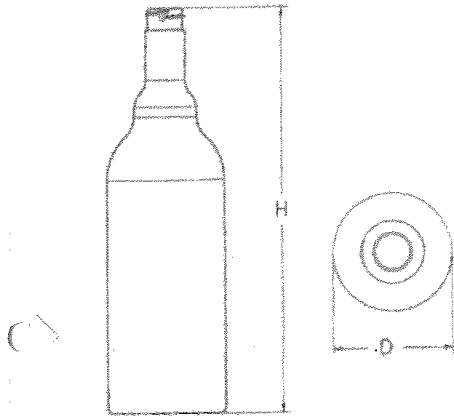

Illustration sheet

This is the first (for example, first) design out of a total of two designs



Exhibit # GPG004  
Page 1 of 1