

# Determination of an Application for an Environmental Permit under the Environmental Permitting (England & Wales) Regulations 2010

## What this document is about

It explains how we have considered the Applicant's Application, and why we have included the specific conditions in the permit we are issuing to the Applicant. It is our record of our decision-making process, to show how we have taken into account all relevant factors in reaching our position. Unless the document explains otherwise, we have accepted the Applicant's proposals.

We try to explain our decision as accurately, comprehensively and plainly as possible. Achieving all three objectives is not always easy, and we would welcome any feedback as to how we might improve our decision documents in future. A lot of technical terms and acronyms are inevitable in a document of this nature: we provide a glossary of acronyms near the front of the document, for ease of reference.

## Preliminary information and use of terms

We gave the application the reference number EPR/LP3239NX/A001. We refer to the application as "the **Application**" in this document in order to be consistent.

The number we have given to the permit is EPR/LP3239NX. We refer to the permit as "the **Permit**" in this document.

The Application was duly made on 14<sup>th</sup> October 2014.

The Applicant is Bulwell Energy Limited. We refer to Bulwell Energy Limited as "the **Applicant**" in this document. Where we are talking about what would happen after the Permit is granted (if that is our final decision), we call Bulwell Energy Limited "the **Operator**".

Bulwell Energy Limited's proposed facility is located at Former Allotments, Blenheim Lane, Bulwell, Nottingham. NG6 8UR. We refer to this as "the **Installation**" in this document.

## How this document is structured

- Glossary of acronyms
- Our proposed decision
- How we reached our decision
- The legal framework
- The Installation
  - Description of the Installation and general issues
  - The site and its protection
  - Operation of the Installation – general issues
- Minimising the installation's environmental impact
  - Assessment Methodology
  - Air Quality Assessment
  - Human health risk assessment
  - Impact on Habitats sites, SSSIs, non-statutory conservation sites etc.
  - Impact of abnormal operations
- Application of Best Available Techniques
  - Scope of Consideration
  - BAT and emissions control
  - BAT and global warming potential
  - BAT and POPs
  - Other Emissions to the Environment
  - Setting ELVs and other Permit conditions
  - Monitoring
  - Reporting
- Other legal requirements
  - The EPR 2010 (as amended) and related Directives
  - National primary legislation
  - National secondary legislation
  - Other relevant legal requirements
- Annexes
  - Application of the Waste Incineration Directive
  - Pre-Operational Conditions
  - Improvement Conditions
  - Consultation Responses

## Glossary of acronyms used in this document

(Please note that this glossary is standard for our decision documents and therefore not all these acronyms are necessarily used in this document.)

APC	Air Pollution Control
AQD	Directive 2008/50/EC of the European Parliament and of the Council of 21 May 2008 on ambient air quality and cleaner air for Europe
BAT	Best Available Technique(s)
BAT-AEL	BAT Associated Emission Level
BREF	BAT Reference Note
CEM	Continuous emissions monitor
CFD	Computerised fluid dynamics
CHP	Combined heat and power
COMEAP	Committee on the Medical Effects of Air Pollutants
CROW	Countryside and rights of way Act 2000
CV	Calorific value
DAA	Directly associated activity – Additional activities necessary to be carried out to allow the principal activity to be carried out
DD	Decision document
EAL	Environmental assessment level
EIAD	Environmental Impact Assessment Directive (85/337/EEC)
ELV	Emission limit value
EMAS	EU Eco Management and Audit Scheme
EMS	Environmental Management System
EPR	Environmental Permitting (England and Wales) Regulations 2010 (SI 2010 No. 675) as amended
EQS	Environmental quality standard
EU-EQS	European Union Environmental Quality Standard
EWC	European waste catalogue
FSA	Food Standards Agency
GWP	Global Warming Potential
HHRAP	Human Health Risk Assessment Protocol
HMIP	Her Majesty's Inspectorate of Pollution
HPA	Health Protection Agency (Public Health England)

HW	Hazardous waste
HWI	Hazardous waste incinerator
IBA	Incinerator Bottom Ash
IED	Industrial Emissions Directive (2010/75/EU)
IPPCD	Integrated Pollution Prevention and Control Directive (2008/1/EC) – now superseded by IED
I-TEF	Toxic Equivalent Factors set out in Annex VI Part 2 of IED
I-TEQ	Toxic Equivalent Quotient calculated using I-TEF
LCPD	Large Combustion Plant Directive (2001/80/EC) – now superseded by IED
LCV	Lower calorific value – also termed net calorific value
LfD	Landfill Directive (1999/31/EC)
LOI	Loss on Ignition
LTHW	Low Temperature Heating Water
MBT	Mechanical biological treatment
MSW	Municipal Solid Waste
MWI	Municipal waste incinerator
NOx	Oxides of nitrogen (NO plus NO <sub>2</sub> expressed as NO <sub>2</sub> )
Opra	Operator Performance Risk Appraisal
PAH	Polycyclic aromatic hydrocarbons
PC	Process Contribution
PCB	Polychlorinated biphenyls
PEC	Predicted Environmental Concentration
POP(s)	Persistent organic pollutant(s)
PPS	Public participation statement
PR	Public register
PXDD	Poly-halogenated di-benzo-p-dioxins
PXB	Poly-halogenated biphenyls
PXDF	Poly-halogenated di-benzo furans
RGS	Regulatory Guidance Series
SAC	Special Area of Conservation
SCR	Selective catalytic reduction
SGN	Sector guidance note

SNCR	Selective non-catalytic reduction
SPA(s)	Special Protection Area(s)
SS	Sewage sludge
SSSI(s)	Site(s) of Special Scientific Interest
SWMA	Specified waste management activity
TDI	Tolerable daily intake
TEF	Toxic Equivalent Factors
TGN	Technical guidance note
TOC	Total Organic Carbon
UHV	Upper heating value –also termed gross calorific value
UN_ECE	United Nations Environmental Commission for Europe
US EPA	United States Environmental Protection Agency
WFD	Waste Framework Directive (2008/98/EC)
WHO	World Health Organisation
WID	Waste Incineration Directive (2000/76/EC) – now superseded by IED

# 1 Our decision

We have decided to grant the Permit to the Applicant. This will allow it to operate the Installation, subject to the conditions in the Permit.

We consider that, in reaching that decision, we have taken into account all relevant considerations and legal requirements and that the permit will ensure that a high level of protection is provided for the environment and human health.

This Application is to operate an installation which is subject principally to the Industrial Emissions Directive (IED).

The Permit contains many conditions taken from our standard Environmental Permit template including the relevant Annexes. We developed these conditions in consultation with industry, having regard to the legal requirements of the Environmental Permitting Regulations and other relevant legislation. This document does not therefore include an explanation for these standard conditions. Where they are included in the permit, we have considered the Application and accepted the details are sufficient and satisfactory to make the standard condition appropriate. This document does, however, provide an explanation of our use of “tailor-made” or installation-specific conditions, or where our Permit template provides two or more options.

## 2 How we reached our decision

### 2.1 Receipt of Application

The Application was duly made on 14<sup>th</sup> October 2014. This means we considered it was in the correct form and contained sufficient information for us to begin our determination but not that it necessarily contained all the information we would need to complete that determination: see below.

The Applicant made no claim for commercial confidentiality. We have not received any information in relation to the Application that appears to be confidential in relation to any party.

## 2.2 Consultation on the Application

We carried out consultation on the Application in accordance with the EPR, our statutory PPS and our own RGS Note 6 for Determinations involving Sites of High Public Interest. We consider that this process satisfies, and frequently goes beyond the requirements of the Aarhus Convention on Access to Information, Public Participation in Decision-Making and Access to Justice in Environmental Matters, which are directly incorporated into the IED, which applies to the Installation and the Application. We have also taken into account our obligations under the Local Democracy, Economic Development and Construction Act 2009 (particularly Section 23). This requires us, where we consider it appropriate, to take such steps as we consider appropriate to secure the involvement of representatives of interested persons in the exercise of our functions, by providing them with information, consulting them or involving them in any other way. In this case, our consultation already satisfies the Act's requirements.

We advertised the Application by a notice placed on our website, which contained all the information required by the IED, including telling people where and when they could see a copy of the Application.

We placed a copy of the Application and all other documents relevant to our determination (see below) on our Public Register at the Environment Agency, Trentside Office, Scarrington Road, Nottingham. NG2. Anyone wishing to see these documents could do so and arrange for copies to be made.

We sent copies of the Application to the following bodies, which includes those with whom we have "Working Together Agreements":

- Local Authority Environmental Protection Department.
- Local Sewerage Undertaker
- Food Standards Agency
- Health and Safety Executive
- Public Health England
- National Grid

These are bodies whose expertise, democratic accountability and/or local knowledge make it appropriate for us to seek their views directly. Note under our Working Together Agreement with Natural England, we only inform Natural England of the results of our assessment of the impact of the installation on designated Habitats sites.

Further details along with a summary of consultation comments and our response to the representations we received can be found in Annex 4. We have taken all relevant representations into consideration in reaching our determination.

### 2.3 Requests for Further Information

Although we were able to consider the Application duly made, we did in fact need more information in order to determine it, and issued an information notice on 21<sup>st</sup> November 2014. A copy of the information notice was placed on our public register, as was the response when received.

## **3 The legal framework**

The Permit will be granted under Regulation 13 of the EPR. The Environmental Permitting regime is a legal vehicle which delivers most of the relevant legal requirements for activities falling within its scope. In particular, the regulated facility is:

- an *installation* and a *waste incineration plant* as described by the IED;
- an *operation* covered by the WFD, and
- subject to aspects of other relevant legislation which also have to be addressed.

We address some of the major legal requirements directly where relevant in the body of this document. Other requirements are covered in a section towards the end of this document.

We consider that, in granting the Permit, it will ensure that the operation of the Installation complies with all relevant legal requirements and that a high level of protection will be delivered for the environment and human health.

We explain how we have addressed specific statutory requirements more fully in the rest of this document.



## 4 The Installation

### 4.1 Description of the Installation and related issues

#### 4.1.1 The permitted activities

The Installation is subject to the EPR because it carries out an activity listed in Part 1 of Schedule 1 to the EPR:

- Section 5.1 Part A (1) (b) – incineration of non-hazardous waste in a waste incineration plant with a capacity exceeding 3 tonnes per hour.

The IED definition of “waste incineration plants” and “waste co-incineration plants” says that it includes:

*“all incineration lines or co-incineration lines, waste reception, storage, on site pre-treatment facilities, waste, fuel and air supply systems, boilers, facilities for the treatment of waste gases, on-site facilities for treatment or storage of residues and waste water, stacks, devices and systems for controlling incineration or co-incineration operations, recording and monitoring incineration or co-incineration conditions.”*

Many activities which would normally be categorised as “directly associated activities” for EPR purposes (see below), such as air pollution control plant and the ash storage bunker, are therefore included in the listed activity description.

The principal purpose of the activities is to dispose of residual Commercial and Industrial Wastes (C&I) and Municipal Solid Wastes (MSW) and to recover energy, which will be used to generate electricity, which will be exported to the National Grid and also to supply power to the site itself. The facility will use a gasification process to process the waste with a calorific value of around 11.75 MJ/kg. The waste will be sourced from a variety of waste operators. Approximately 160,000 tonnes / year of waste, which otherwise would be expected to go to landfill, will be processed, generating 30 MWe of electricity.

A further estimated 4,640 tonnes of ferrous and non-ferrous metals would also be recovered post processing each year; these materials are currently landfilled.

Un-processed material will be delivered to the location in trucks directly into the waste material storage area, and will be moved by front loaders around the storage area to mix and pile the waste. On entry to the site each vehicle will be weighed, the vehicles will then proceed to a truck unloading area. The vehicles will discharge their load via the back – end tipping facility

incorporated within each truck. Once emptied, the trucks will then exit the site via an out-feed weigh bridge.

The un-processed waste material will be stored in a reception hall with vertical push walls to allow the materials to be piled and mixed. This material will then be fed using front loaders and mobile crane grab into the gasifier charge bins via a loading conveyor.

The wastes are treated at controlled temperatures, under a low oxygen atmosphere which enables their organic content to be degraded and transformed into gaseous components known as synthetic gas or 'syngas'. A solid residue is also produced, which remains in the processing bin. The heat source required to initiate this gasification process is provided by an oxy-fuelled natural gas burner housed within the heating chamber.

The syngas will be used to fuel gas engines and to generate steam in a combined cycle waste heat recovery boiler to drive a steam turbine. The engines and turbine will be used to generate 30MW of electricity, of which 4.2MWe will be utilised to meet the site's electrical demand, with the remaining 25.8MWe being exported to the local electricity grid.

Emissions to air from the process will be via a 50m high exhaust stack. This exhaust stack will be fitted with continuous emission monitors (CEMs) to monitor emissions of particulates, nitrogen oxides, sulphur dioxide, volatile organic compounds, ammonia, carbon monoxide, hydrogen chloride, total organic carbon and oxygen. Water emissions are predominately intermittent boiler blowdown which will be discharged to foul sewer. Treated water from the waste water treatment plant will be either reused in the process or discharged to a trade effluent sewer.

Together, these listed and directly associated activities comprise the Installation.

#### 4.1.2 The Site

The application site is approximately 6.9 hectares and is located to the north of Nottingham in Bulwell Ward. It is situated on the edge of Blenheim Business Park, which contains a range of industrial, warehousing and distribution units.

The site is centred on Grid Ref SK 53055 46105. The southern boundary of the site is hedgerow beyond which is Blenheim Lane. The eastern boundary of the site is defined by Firth Way. To the west and north are allotments and Nottingham City Golf Course, which is itself, part of Bulwell Hall Park. Hucknall Airfield is to the northwest of the relocated allotments.

The nearest residential properties are located some 140m to the southeast of the site entrance on Bardney Drive, with Norwich Gardens 350m to the east and Sellers Wood Drive estate some 450m to the southwest beyond the

Blenheim Industrial Estate. Rufford Primary and Nursery School is located 450m to the southeast.

There are no internationally designated sites of nature conservation within 10km of the site, there are however two nationally designated sites of nature conservation importance within 2km, these being Sellers Wood, Site of Special Scientific Importance (SSSI) 500m to the southwest of the site and Bulwell Wood (SSSI) 1,100m to the west of the site. There are also four local nature reserves (LNR) within 2km, Moorbridge Pond and Springfield Corner, Hucknall Road linear walkway, Sellers Wood and Bulwell Hall Park Meadow.

The Applicant submitted a plan which we consider is satisfactory, showing the site of the Installation and its extent. A plan is included in Schedule 7 to the Permit, and the Operator is required to carry on the permitted activities within the site boundary.

Further information on the site is addressed below at 4.3.

#### 4.1.3 What the Installation does

The Applicant has described the facility as a 'Energy Recovery Installation'. Our view is that for the purposes of IED (in particular Chapter IV) and EPR, the installation is a waste incineration plant because notwithstanding the fact that waste will be thermally treated by the process; the process is never the less 'incineration' because it is considered that main purpose of this plant is the destruction of waste for generation of energy.

Each of the 2 Gasifiers is operated as a batch system with a set mass of material (21.33 tonnes) loaded into the processing bin and gasified over a set time period (two hours) i.e. a processing rate for each unit of 10.67 tonnes per hour. The process commences when the Gasifier itself starts to rotate; this rotation continues throughout the cycle. The process is initiated by an oxy-fuelled natural gas burner in the heating chamber; when the temperature in the heating chamber reaches 900<sup>o</sup>C and the temperature in the combined waste heat recovery boiler is >850<sup>o</sup>C, the Gasifier starts to rotate. The material does not leave the processing bin until the Gasifier starts to rotate. The rotation enables the material to pass into the incoming hot gas stream, where it is gasified and the syngas produced in each unit's processing chamber is passed to its dedicated thermal reactor for superheating the syngas to a temperature in excess of 1100<sup>o</sup>C in order to crack the tars and long chain hydrocarbons. A stable heat source in the thermal reactor is provided by an oxyfuelled natural gas burner to the thermal reactor. The superheated cracked syngas from each thermal reactor is passed through a dedicated syngas waste heat recovery boiler with the steam generated from this first stage heat recovery process being transferred to the combined cycle waste heat recovery boiler where it is combined with the rest of the steam inputs (generated in the combined cycle waste heat recovery boiler). This superheated steam is used in the high efficiency steam turbine generator set. The cooled syngas leaving the first stage heat recovery process is cleaned by passing through a ceramic filter with Lime dosing system.

The cleaned, filtered syngas is then diverted to three different locations depending on its calorific value quality and requirement. These are –

1. Direct syngas combustion within the boiler combustor section of the combined cycle waste heat recovery boiler.
2. Quench & further syngas (high CV syngas) cleaning through a wet scrubbing process, H<sub>2</sub>S stripping, tar scrubbing, syngas storage and then combustion in gas engines. The exhaust gases from the gas engines again passing to the boiler combustor section of the combined cycle waste heat recovery boiler.
3. Quench (low CV syngas), syngas storage and then direct syngas combustion within the boiler combustor section of the combined cycle waste heat recovery boiler.

As such, regardless of which of the three routes through which the syngas passes, all gases (either syngas or exhaust gases from the gas engines) pass through the combustor section of the combined cycle waste heat recovery boiler (the final stage of combustion and also where NO<sub>x</sub> control via Ammonium Hydroxide is undertaken) which is common to all three routes prior to heat recovery via the common combined cycle waste heat boiler, flue gas cleaning via the bag filter with Lime injection and discharge via the common exhaust stack. A stable heat source in the combustor section of the combined cycle waste heat recovery boiler is provided by a natural gas burner which maintains the temperature at 900°C. If the temperature recorded by any of the thermocouples located within the combustor section of the combined cycle waste heat recovery boiler falls below 850°C, then rotation of any rotating Gasifiers automatically ceases, thereby halting the gasification process and the gas engines cease to operate. Any residual syngas is sent for storage. As such, the combustor section of the combined cycle waste heat recovery boiler ceases to receive any gases (either exhaust gas from the gas engines or syngas) from any of the three inputs described above and thus combustion (other than that of natural gas in the natural gas burner located in the combustor section of combined cycle waste heat recovery boiler) ceases. Similarly, if the continuous emission monitors show that an emission limit value (ELV) has been exceeded due to disturbances or failures of the abatement equipment, then the above procedure is again put in to place to ensure that the combustor section of the combined cycle waste heat recovery boiler ceases to receive any gases from any of the three inputs and thus combustion of them ceases.

We consider, therefore, that the system meets the requirements of the IED Article 52(4).

Audible and visual alarms will be triggered when the temperatures fall below the minimum required for both the processing chamber and the combustor section of the combined cycle waste heat recovery boiler (minimum temperature of 850°C in accordance with the IED).

Gas temperatures are therefore continually monitored and recorded at the entry point, throughout the combustor section of the combined cycle waste heat recovery boiler and at the exit point.

Operational conditions will be optimised in order to minimise the quantity of residues (ash) produced. Oxygen levels in the processing chamber of each Gasifier are monitored and controlled throughout to enable efficient

gasification of the material prior to combustion of the resultant syngas. By increasing Oxygen levels at the end of each cycle in the processing chamber, any residual Carbon can be 'burnt out'.

As a gasification plant, the IED 3% TOC requirement applies to the ash produced. The residue remaining in the processing bin therefore will be tested to show compliance with this requirement.

The combustor section of the combined cycle waste heat recovery boiler itself and the entrance points to it have been designed in order to increase turbulence within the combustion chamber, thereby reducing NO<sub>x</sub> formation, secondary air requirements and overall flue gas volumes.

Combustion air is continually monitored and controlled in order to minimise NO<sub>x</sub> production and minimise velocities and the entrainment of particulates. The combustor section of the combined cycle waste heat recovery system has an auxiliary natural gas burner, which will be triggered should the temperature fall below 900°C.

The oxygen level will be monitored and controlled to ensure that there is sufficient for adequate combustion and will be reported on a wet basis. Oxygen levels will be controlled to between 3 – 5% during the process and then raised in the final phase to 8 – 10% to reduce carbon content. There are three oxygen probes in the flue gas exhaust duct, the readings from which are used as the process variable into the PID loop controlling the oxygen level.

Dump stacks and bypass systems will only be operated in accordance with the indicative BAT requirements in EPR 5.01.

Wash-water will be collected and recycled from bottom hoppers designed for water drainage enabling treatment prior to discharge to the foul drainage system.

Boiler blow-down volumes are a function of the impurities in the feedwater, which will be minimised through the selection of an appropriate demineralisation process for the water treatment plant. The main water treatment plant process will be based on reverse osmosis with both pre and post treatment stages.

Boiler blow down discharge to the foul drainage system will be cooled prior to discharge.

# Plant Layout

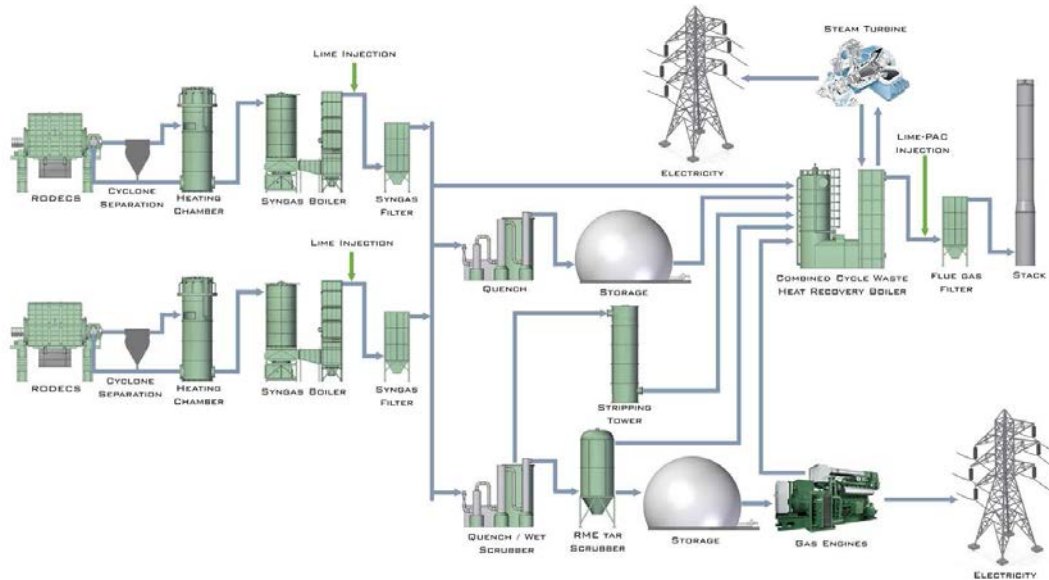

The key features of the Installation can be summarised in the table below.

Waste Throughput, Tonnes / Gasifier	160,000 tonnes per annum maximum	Nominal 10.67 tonnes per hour (2 lines)
Waste processed	Municipal Solid Waste (MSW) and Commercial and Industrial Waste(C&I)	
Number of Gasifiers	2	
Auxiliary Fuel	Natural Gas	
Acid gas abatement	Dry Lime Injection	
NOx abatement	SNCR	Ammonium Hydroxide
Reagent consumption	Ammonium Hydroxide: 341 te/annum Hydrated Lime: 3,427 te/annum Activated carbon: 77.0 te/annum	
Flue gas recirculation	Combustion section of the combined cycle waste heat recovery boiler will combust syngas along with the engine exhaust gases. i.e. indirect FGR.	
Dioxin abatement	Powdered Activated Carbon Injection	
Stack	Height, 50m	Diameter, 1.59m
Flue gas	Flow, 31.6Nm <sup>3</sup> /s	Velocity, 24.3m/s
Electricity generated	225,000MWh Annually	30MW (max output)
Electricity exported	193,500MWh Annually	31,500MWh Parasitic
Heat energy exported	None	CHP ready

#### 4.1.4 Key Issues in the Determination

The key issues arising during this determination were the potential for emissions to air and we therefore describe how we determined these issues in most detail in this document.

#### 4.2 The site and its protection

##### 4.2.1 Site setting, layout and history

A Site Condition Report detailing the environmental setting of the site (including geology, hydrogeology and hydrology), pollution history and historical land use of the proposed site has been compiled by the applicant.

The proposed installation is roughly square in shape, covers a total area of approximately 7 hectares and is located on the northern side of Blenheim Lane, Bulwell, Nottingham, UK; approximately 4.5 miles to the northwest of Nottingham city centre (grid reference 453050 346080).

In terms of the surrounding off-site land use includes: To the **northeast** lies Nottingham City Golf Course; To the **northwest** lie allotment gardens with several associated sheds, beyond which is Hucknall's Rolls-Royce Aerodrome (in use since 1916 to date); To the **southwest** lies Blenheim Road, beyond which are industrial/commercial properties; and to the **southeast** lies Firth Way and a tarmacadam lorry park, beyond which is a distribution warehouse and further commercial/industrial properties. The nearest residential properties are approximately 140m to the southeast.

With reference to the series of Ordnance Survey maps the site mainly has a history of previously being used as allotment gardens but is currently vacant open land. Walkovers at the site identified that the majority of the site is overgrown with vegetation including long grass, wildflowers and some established trees. Any former site buildings/allotment structures have been demolished with occasional areas of rubble from the demolished allotment buildings being present. Some fly tipping was present across the site.

Based on published maps, the nearest surface water feature to the site is a small unnamed watercourse, approximately 300m to the west of the site. The watercourse flows towards the north-northwest, and ceases after approximately 170m. The River Leen is located approximately 1.1km to the east of the site at its closest point, flowing towards the south. The Environment Agency classifies the water quality (biological and chemical) in the River Leen, as 'good' to 'very good'. No water quality data is available for the small unnamed watercourse to the west of the site. The site is not located in an area at risk of flooding from rivers and seas and does not benefit from flood defences. A flood risk assessment concluded that the flood risk to the site was low and in addition, potential flood risks to off-site facilities from the proposed development were also low.

There are no recorded surface water abstractions with a 2km radius of the site.

There are no Special Areas of Conservation (SAC), Special Protection Areas (SPA), RAMSAR sites, Areas of Outstanding Natural Beauty (AONB), national Nature Reserves or other ecologically designated sites identified within a 10km radius of the site. A historic hedgerow is present on the southern site boundary and is designated as a Biological Site of Importance to Nature Conservation (BSINC) (Reference 5/2115). Two further BSINCs are present within close proximity to the site, Bulwell Hall Park (approximately 800m to the north), and Hucknall Airfield (approximately 200m to the northwest). Two Sites of Special Scientific Interest (SSSI) were identified within a 2km radius of the site, namely Sellars Wood (approximately 400m southwest of the site) and Bulwell Wood (approximately 900m west of the site). There are two local Nature Reserves within 1km of the site – Sellars Wood (as above) and Bulwell Hall Park Meadows (approximately 600m north of the site). The site is located within an area identified as a nitrate vulnerable zone. The area immediately beyond the north-eastern boundary of the site, including the Nottingham City Golf Course, is identified as an area of adopted green belt.

#### 4.2.2 Proposed site design: potentially polluting substances and prevention measures

The waste acceptance procedures proposed comply with the indicative BAT guidance given in EPR 5.01 and the requirements of Article 52 of the IED. Waste will be sourced from dedicated waste suppliers thereby reducing variations in feed composition and removing materials that cannot be treated by the installation, thus minimising unnecessary waste production. Waste will be delivered by trucks direct to the waste storage area, which will be covered in hard-standing with appropriate drainage. Waste will be visually inspected when tipped in the unprocessed waste storage area and any contraries removed and placed in a quarantined area in the unprocessed waste storage area in a suitable container or pen prior to being taken offsite for disposal using appropriately licensed facilities. Records will be made of these items and the Environment Agency will be informed. However, as the material will be delivered from dedicated waste suppliers, the likelihood of such items being present in the incoming waste is expected to be extremely low.

As part of the process, three residue waste streams will be produced. Gasifier char (comprising metals, aggregates and glass) will be further processed and have material recovery, syngas and flue gas cleaning residues for disposal to landfill and solid residues from the waste water treatment plant for disposal to landfill off site.

There will be no discharges off site except emissions to air, be it point source or diffuse to any natural receptors, and therefore no impact on the surrounding hydrological and hydrogeological regime. This applies in both the construction and operational phases of the installation.



The proposed installation will use a number of materials/substances to augment the primary and secondary abatement operations. As part of standard operational procedures and in accordance with the Environmental Management System, a full inventory will be maintained at all times of all the materials stored on site, along with their quantity and condition.

There will be no discharges off site, be it point source or diffuse to any natural receptors, and therefore no impact on the surrounding hydrological and hydrogeological regime.

Article 22(2) of the IED states that the Applicant is required to provide a baseline report containing at least the information set out in paragraphs (a) and (b) of the Article before starting operation. Because the site has no historic industrial use the baseline report concludes that there is no historical pollution or contamination. The baseline report is an important reference document in the assessment of contamination that might arise during the operational lifetime of the installation and at cessation of activities at the installation.

#### 4.2.3 Closure and decommissioning

Pre-operational condition PO3 requires the Operator to have an Environmental Management System in place before the Installation is operational, and this will include a site closure plan.

At the definitive cessation of activities, the Operator has to satisfy us that the necessary measures have been taken so that the site ceases to pose a risk to soil or groundwaters, taking into account both the baseline conditions and the site's current or approved future use. To do this, the Operator has to apply to us for surrender, which we will not grant unless and until we are satisfied that these requirements have been met.

### 4.3 Operation of the Installation – general issues

#### 4.3.1 Administrative issues

The Applicant is the sole Operator of the Installation.

We are satisfied that the Applicant is the person who will have control over the operation of the Installation after the granting of the Permit; and that the Applicant will be able to operate the Installation so as to comply with the conditions included in the Permit.

The incineration of waste is not a specified waste management activity (SWMA). The Environment Agency has considered whether any of the other

activities taking place at the Installation are SWMAs and is satisfied that none are taking place.

We are satisfied that the Applicant's submitted Opra profile is accurate.

The Opra score will be used as the basis for subsistence and other charging, in accordance with our Charging Scheme. Opra is the Environment Agency's method of ensuring application and subsistence fees are appropriate and proportionate for the level of regulation required.

#### 4.3.2 Management

The Applicant has stated in the Application that they will implement an Environmental Management System (EMS) that will be certified under ISO14001. The Environment Agency recognises that certification of the EMS cannot take place until the Installation is operational. An improvement condition (IC1) is included requiring the Operator to report progress towards gaining accreditation of its EMS.

We are satisfied that appropriate management systems and management structures will be in place for this Installation, and that sufficient resources are available to the Operator to ensure compliance with all the Permit conditions.

#### 4.3.3 Site security

Having considered the information submitted in the Application, we are satisfied that appropriate infrastructure and procedures will be in place to ensure that the site remains secure.

#### 4.3.4 Accident management

The Applicant has submitted an Accident Management Plan. Having considered the Plan other information submitted in the Application, we are satisfied that appropriate measures will be in place to ensure that accidents that may cause pollution are prevented but that, if they should occur, their consequences are minimised. An Accident Management Plan will form part of the Environmental Management System and must be in place prior to commissioning as required by a pre-operational condition (PO1).

#### 4.3.5 Off-site conditions

We do not consider that any off-site conditions are necessary.

#### 4.3.6 Operating techniques

We have specified that the Applicant must operate the Installation in accordance with the following documents contained in the Application:

Description	Parts Included	Justification
Application	Section 2 None Technical Summary, Section 5.6 Detailed Process Description, Section 8 Monitoring and Section 9 Resource Efficiency.	Duly Made 14/10/2014
Response to Schedule 5 Notice dated 21/11/2014	Emissions and volumetric flow rates.	Clarification of emissions and base data upon impact modelling that was undertaken by the Applicant.

The details set out above describe the techniques that will be used for the operation of the Installation that have been assessed by the Environment Agency as BAT; they form part of the Permit through Permit condition 2.3.1 and Table S1.2 in the Permit Schedules.

Article 45(1) of the IED requires that the Permit must include a list of all types of waste which may be treated using at least the types of waste set out in the European Waste List established by Decision 2005/532/EC, EC, if possible, and containing information on the quantity of each type of waste, where appropriate. The Application contains a list of those wastes in Section 5.4 "Waste acceptance and handling", coded by the European Waste Catalogue (EWC) number, which the Applicant will accept in the waste streams entering the plant and which the plant is capable of processing in an environmentally acceptable way. We have specified the permitted waste types, descriptions and where appropriate quantities which can be accepted at the installation in Table S2.2 of the Permit.

We are satisfied that the Applicant can accept the wastes contained in Table S2.2 of the Permit because: -

- (i) the wastes are all categorised as non-hazardous in the European Waste Catalogue and are capable of being safely treated at the installation.
- (ii) these wastes are likely to be within the design calorific value (CV) range for the plant;
- (iii) these wastes are unlikely to contain harmful components that cannot be safely processed at the Installation.

We have limited the capacity of the Installation to 160,000 tonnes per annum. This is based on the installation operating 7,500 hours (subject to maintenance) per year at a nominal capacity of 21.33 tonnes per hour.

The Installation will be designed, constructed and operated using BAT for the incineration of the permitted wastes. We are satisfied that the operating and

abatement techniques are BAT for incinerating these types of waste. Our assessment of BAT is set out later in this document.

#### 4.3.7 Energy efficiency

##### (i) Consideration of energy efficiency

We have considered the issue of energy efficiency in the following ways:

1. The use of energy within, and generated by, the Installation which are normal aspects of all EPR permit determinations. This issue is dealt with in this section.
2. The extent to which the Installation meets the requirements of Article 50(5) of the IED, which requires *“the heat generated during the incineration and co-incineration process is recovered as far as practicable through the generation of heat, steam or power”*. This issue is covered in this section.
3. The combustion efficiency and energy utilisation of different design options for the Installation are relevant considerations in the determination of BAT for the Installation, including the Global Warming Potential of the different options. This aspect is covered in the BAT assessment in section 6 of this Decision Document.

(ii) Use of energy within the Installation

Having considered the information submitted in the Application, we are satisfied that appropriate measures will be in place to ensure that energy is used efficiently within the Installation.

The Application details a number of measures that will be implemented at the Installation in order to increase its energy efficiency including

- Plant design, specific choice of motors and/or drivers to minimise the energy requirements of conveyors, fans, pumps, etc.
- Heat energy will be recovered wherever possible in the system, the steam generated by the waste heat boilers will be utilised by the steam turbine in order to generate further electricity.
- The use of waste heat in the pre-heater and in secondary combustion (ie FGR) this is a key design element for thermal efficiency in the combustion process.
- The layout of the process has been optimised to safeguard direct flow lines and minimise the need for transfer points and liquid pumping distances.
- Effective furnace insulation and construction to retain heat using advanced refractory linings.
- Maintaining steady plant capacity to prevent downtime.
- A continued monitoring system will be in place, monitoring all elements of the installation such as effective maintenance of heat exchangers to maintain high rates of heat transfer, this ensures the best use of energy at all times.
- Use of ion exchange instead of high pressure membrane filtration for boiler (and other water) treatment.

The Application states that the specific energy consumption, a measure of total energy consumed per unit of waste processed, will be 200kWh/tonne. The installation capacity is 160,000 t/a. Data from the BREF for Municipal Waste Incinerators shows that the range of specific energy consumptions is as in the table below.

<b>MSWI plant size range (t/yr)</b>	<b>Process energy demand (kWh/t waste input)</b>
Up to 150,000	300 – 700
150,000 – 250,000	150 – 500
More than 250,000	60 – 200

The BREF says that it is BAT to reduce the average installation electrical demand to generally below 150 kWh/tonne of waste with an LCV of 10.4 MJ/kg. The LCV in this case is expected to be 11.75MJ/kg. Taking account of the difference in LCV, the specific energy consumption in the Application is in line with that set out above.

(iii) Generation of energy within the Installation - Compliance with Article 50(5) of the IED

Article 50(5) of the IED requires that *“the heat generated during the incineration and co-incineration process is recovered as far as practicable”*.

Our CHP Ready Guidance (February 2013) considers that BAT for energy efficiency for Energy from Waste (EfW) plant is the use of CHP in circumstances where there are technically and economically viable opportunities for the supply of heat from the outset.

The term CHP in this context represents a plant which also provides a supply of heat from the electrical power generation process to either a district heating network or to an industrial / commercial building or process. However, it is recognised that opportunities for the supply of heat do not always exist from the outset (i.e. when a plant is first consented, constructed and commissioned).

In cases where there are no immediate opportunities for the supply of heat from the outset, the Environment Agency considers that BAT is to build the plant to be CHP Ready (CHP-R) to a degree which is dictated by the likely future opportunities which are technically viable and which may, in time, also become economically viable.

The BREF says that where a plant generates electricity only, it is BAT to recover 0.4 – 0.65 MWh/ tonne of waste (based on LCV of 10.4 MJ/kg). Our technical guidance note, SGN EPR S5.01, states that where electricity only is generated, 5-9 MW of electricity should be recoverable per 100,000 tonnes/annum of waste (which equates to 0.4 – 0.72 MWh/tonne of waste).

The Installation will generate electricity only and has been specified to maximise electrical output with appropriate use of waste heat. The Sankey diagram and table of specific energy consumption in Section 9 of the Application shows 30MW of electricity produced for an annual treatment of 160,000 tonnes which represents 10.75MW per 100,000 tonnes/yr of waste burned. The Installation is therefore high up in the indicative BAT range.

The SGN and Chapter IV of the IED both require that, as well as maximising the primary use of heat to generate electricity; waste heat should be recovered as far as practicable. i.e. by identifying and utilising opportunities for Combined Heat and Power (CHP) and district heating. Where steam or hot water are raised for use in an industrial process or for district heating the

potential efficiency of electrical power generation is reduced but overall energy efficiency can be significantly improved depending upon finding a demand for heat produced by the facility.

The location of the Installation largely determines the extent to which waste heat can be utilised, and this is a matter for the planning authority. The proposed plant has been designed with the ability to export “low grade” heat to third parties, however no feasible receiver of this energy has been found at this time, the Operator intends to review this position on a regular basis.

We consider that, within the constraints of the location of the Installation explained above, the Installation will recover heat as far as practicable, and therefore that the requirements of Article 6(6) are met.

(vii) Permit conditions concerning energy efficiency

Pre-operational condition PO4 requires the Operator to carry out a comprehensive review of the available heat recovery options prior to commissioning, in order to ensure that waste heat from the plant is recovered as far as possible.

Conditions 1.2.2 and 1.2.3 have also been included in the Permit, which require the Operator to review the options available for heat recovery on an ongoing basis, and to provide and maintain the proposed steam/hot water pass-outs.

The Operator is required to report energy usage and energy generated under condition 4.2 and Schedule 5 of the Permit. The following parameters are required to be reported: total electrical energy generated; electrical energy exported; total energy usage and energy exported as heat (if any). Together with the total MSW and C&I burned per year, this will enable the Environment Agency to monitor energy recovery efficiency at the Installation and take action if at any stage the energy recovery efficiency is less than proposed.

There are no site-specific considerations that require the imposition of standards beyond indicative BAT, and so the Environment Agency accepts that the Applicant’s proposals represent BAT for this Installation.

4.3.8 Efficient use of raw materials

Having considered the information submitted in the Application, we are satisfied that the appropriate measures will be in place to ensure the efficient use of raw materials and water.

The Operator is required to report with respect to raw material usage under condition 4.2. and Schedule 5 of the Permit, including consumption of activated carbon and ammonium hydroxide used per tonne of waste burned. This will enable the Environment Agency to assess whether there have been any changes in the efficiency of the air pollution control plant, and the operation of the SNCR to abate NO<sub>x</sub>. These are the most significant raw

materials that will be used at the Installation, other than the waste feed itself (addressed elsewhere). The efficiency of the use of auxiliary fuel will be tracked separately as part of the energy reporting requirement under condition 4.2.1 of the Permit. Optimising reagent dosage for air abatement systems and minimising the use of auxiliary fuels is further considered in the section on BAT.

#### 4.3.9 Avoidance, recovery or disposal with minimal environmental impact of wastes produced by the activities

This requirement addresses wastes produced at the Installation and does not apply to the waste being treated there. The principal waste streams the Installation will produce are char from the gasification plant and air pollution control residues.

The first objective is to avoid producing waste at all. Waste production will be avoided by achieving a high degree of reduction of the material (MSW and C&I) processed. The char, which results, is a material that is both reduced in volume and in chemical reactivity. Condition 3.1.3 and associated Table S3.4 specify limits for Total Organic Carbon (TOC) remaining in the char of <3%. Compliance with this limit will demonstrate that good thermal control and waste feed destruction is being achieved in the furnaces and waste generation is being avoided where practicable.

Gasifier char will normally be classified as non-hazardous waste. However, char is classified on the European List of Wastes as a “mirror entry”, which means char is a hazardous waste if it possesses a hazardous property relating to the content of dangerous substances. Monitoring of the char will be carried out in accordance with the requirements of Article 53(3) of IED. Classification of char for its subsequent use or disposal is controlled by other legislation and so is not duplicated within the permit.

Air pollution control (APC) residues from flue gas treatment are hazardous waste and therefore must be sent for disposal to a landfill site permitted to accept hazardous waste, or to an appropriately permitted facility for hazardous waste treatment. The amount of APC residues is minimised through optimising the performance of the air emissions abatement plant.

In order to ensure that the char and APC residues are adequately characterised, pre-operational condition PO5 requires the Operator to provide a written plan for approval detailing the ash sampling protocols. Table S3.3 requires the Operator to carry out an ongoing programme of monitoring.

Having considered the information submitted in the Application, we are satisfied that the waste hierarchy referred to in Article 4 of the WFD will be applied to the generation of waste and that any waste generated will be treated in accordance with this Article.

We are satisfied that all metals will be recovered from the waste feedstock, any waste from the Installation that cannot be recovered will be disposed of



using a method that minimises any impact on the environment. Standard condition 1.4.1 will ensure that this position is maintained.

## **5. Minimising the Installation's environmental impact**

Regulated activities can present different types of risk to the environment, these include odour, noise and vibration; accidents, fugitive emissions to air and water; as well as point source releases to air, discharges to ground or groundwater, global warming potential and generation of waste. Consideration may also have to be given to the effect of emissions being subsequently deposited onto land (where there are ecological receptors). All these factors are discussed in this and other sections of this document.

For an installation of this kind, the principal emissions are those to air, although we also consider those to land and water.

The next sections of this document explain how we have approached the critical issue of assessing the likely impact of the emissions to air from the Installation on human health and the environment and what measures we are requiring to ensure a high level of protection.

### **5.1 Assessment Methodology**

#### **5.1.1 Application of Environment Agency H1 Guidance**

A methodology for risk assessment of point source emissions to air, which we use to assess the risk of applications we receive for permits, is set out in our Horizontal Guidance Note H1 and has the following steps:

- Describe emissions and receptors
- Calculate process contributions
- Screen out insignificant emissions that do not warrant further investigation
- Decide if detailed air modelling is needed
- Assess emissions against relevant standards
- Summarise the effects of your emissions

The H1 methodology uses a concept of “process contribution (PC)”, which is the estimated concentration of emitted substances after dispersion into the receiving environmental media at the point where the magnitude of the concentration is greatest. The guidance provides a simple method of calculating PC primarily for screening purposes and for estimating process contributions where environmental consequences are relatively low. It is based on using dispersion factors. These factors assume worst case dispersion conditions with no allowance made for thermal or momentum plume rise and so the process contributions calculated are likely to be an overestimate of the actual maximum concentrations. More accurate calculation of process contributions can be achieved by mathematical dispersion models, which take into account relevant parameters of the release

and surrounding conditions, including local meteorology – these techniques are expensive but normally lead to a lower prediction of PC.

### 5.1.2 Use of Air Dispersion Modelling

For incineration applications, we normally require the Applicant to submit a full air dispersion model as part of their application. Air dispersion modelling enables the process contribution to be predicted at any environmental receptor that might be impacted by the plant.

Once short-term and long-term PCs have been calculated in this way, they are compared with Environmental Quality Standards (EQS) referred to as “benchmarks” in the H1 Guidance.

Where an EU EQS exists, the relevant standard is the EU EQS. Where an EU EQS does not exist, our guidance sets out a National EQS (also referred to as Environmental Assessment Level - EAL) which has been derived to provide a similar level of protection to Human Health and the Environment as the EU EQS levels. In a very small number of cases, e.g. for emissions of Lead, the National EQS is more stringent than the EU EQS. In such cases, we use the National EQS standard for our assessment.

National EQSs do not have the same legal status as EU EQSs, and there is no explicit requirement to impose stricter conditions than BAT in order to comply with a national EQS. However, national EQSs are a standard for harm and any significant contribution to a breach is likely to be unacceptable.

PCs are considered **Insignificant** if:

- the **long-term** process contribution is less than **1%** of the relevant EQS; and
- the **short-term** process contribution is less than **10%** of the relevant EQS.

The **long term** 1% process contribution insignificance threshold is based on the judgements that:

- It is unlikely that an emission at this level will make a significant contribution to air quality;
- The threshold provides a substantial safety margin to protect health and the environment.

The **short term** 10% process contribution insignificance threshold is based on the judgements that:

- spatial and temporal conditions mean that short term process contributions are transient and limited in comparison with long term process contributions;
- the proposed threshold provides a substantial safety margin to protect health and the environment.

Where an emission is screened out in this way, we would normally consider that the Applicant’s proposals for the prevention and control of the emission to

be BAT. That is because if the impact of the emission is already insignificant, it follows that any further reduction in this emission will also be insignificant.

**However, where an emission cannot be screened out as insignificant, it does not mean it will necessarily be significant.**

For those pollutants which do not screen out as insignificant, we determine whether exceedences of the relevant EQS are likely. This is done through detailed audit and review of the Applicant's air dispersion modelling taking background concentrations and modelling uncertainties into account. Where an exceedence of an EU EQS is identified, we may require the Applicant to go beyond what would normally be considered BAT for the Installation or refuse the application. Whether or not exceedences are considered likely, the application is subject to the requirement to operate in accordance with BAT.

This is not the end of the risk assessment, because we also take into account local factors (for example, particularly sensitive receptors nearby such as a SSSIs, SACs or SPAs). These additional factors may also lead us to include more stringent conditions than BAT.

If, as a result of reviewing of the risk assessment and taking account of any additional techniques that could be applied to limit emissions, we consider that emissions **would cause significant pollution**, we would refuse the Application.

## **5.2 Assessment of Impact on Air Quality**

The Applicant's assessment of the impact of air quality is set out in Appendix "J" of the Application. A Human Health Impact assessment report and addendum report were submitted in response to a Schedule 5 request for specific information relating to assessments that were missing from the original Application. The assessment comprises:

- An H1 screening assessment of emissions to air from the operation of the incinerator.
- Dispersion modelling of emissions to air from the operation of the incinerator.
- A study of the impact of emissions on nearby sensitive habitat / conservation sites.

This section of the decision document deals primarily with the dispersion modelling of emissions to air from the incinerator exhaust stack and its impact on local air quality. The impact on conservation sites is considered in section 5.4

The Applicant has assessed the Installation's potential emissions to air against the relevant air quality standards, and the potential impact upon local conservation and habitat sites and human health. These assessments predict the potential effects on local air quality from the Installation's stack emissions using the ADMS 5 dispersion model, which is a commonly used computer model for regulatory dispersion modelling. The model used 5 years of

meteorological data collected from the weather station at Nottingham Watnall between 2008 and 2012. This site is only 3km from the proposed installation and is therefore considered representative. The impact of the terrain surrounding the site upon plume dispersion was considered in the dispersion modelling.

The air impact assessments, and the dispersion modelling upon which they were based, employed the following assumptions.

- First, they assumed that the emission rates derived from the maximum permitted by Chapter IV, Annex VI, Part 3 of the IED, with the exception of NO<sub>x</sub> (The Applicant proposes an ELV of 90mg/Nm<sup>3</sup>) and SO<sub>2</sub> (The Applicant proposes an ELV of 40mg/Nm<sup>3</sup>). These substances are:
  - Oxides of nitrogen (NO<sub>x</sub>), expressed as NO<sub>2</sub>
  - Total dust
  - Carbon monoxide (CO)
  - Sulphur dioxide (SO<sub>2</sub>)
  - Hydrogen chloride (HCl)
  - Hydrogen fluoride (HF)
  - Metals (Cadmium, Thallium, Mercury, Antimony, Arsenic, Lead, Chromium, Cobalt, Copper, Manganese, Nickel and Vanadium)
  - Polychlorinated dibenzo-para-dioxins and polychlorinated dibenzo furans (referred to as dioxins and furans)
  - Gaseous and vaporous organic substances, expressed as Total Organic Carbon (TOC)
- Second, they assumed that the Installation operates continuously at the relevant long-term or short-term emission limit values, i.e. the maximum permitted emission rates under IED
- We are in agreement with this approach. The assumptions underpinning the model have been checked.

The way in which the Applicant used dispersion models, its selection of input data, use of background data and the assumptions it made have been reviewed by the Environment Agency's modelling specialists to establish the robustness of the Applicant's air impact assessment. The output from the model has then been used to inform further assessment of health impacts and impact on habitats and conservation sites.

Whilst we have expressed a number of reservations with the way in which the modelling work was done and we issued a Schedule 5 Notice on 21<sup>st</sup> November 2014 requesting further information and clarification of the Applicant's dispersion modelling assessment, we agree with the Applicant's conclusions. We have also audited the air quality and human health impact assessment and similarly agree that the conclusions drawn in the reports were acceptable.

The Applicant's modelling predictions are summarised in the following sections.

## 5.2.1 Assessment of Air Dispersion Modelling Outputs

The Applicant's modelling predictions are summarised in the tables below. The figures shown indicate the predicted peak ground level exposure to pollutants in ambient air.

### (i) Long Term

Pollutant	Period	EQS	Back-ground Conc.	Process Contribution (PC)	PC as % of EQS	Predicted Environmental Concentration (PEC)	PEC as % EQS
PM10	Annual mean (1hr)	40	16.4	0.07	0.2	16.47	41.17
HF	Annual mean (1hr)	16	-	0.007	0.0	-	-
NO <sub>2</sub>	Annual mean (1hr)	40	22.29	0.44	1.1	22.73	56.8
Cd <sub>(ng/m3)</sub>	Annual mean (1hr)	5	0.19	0.00018	3.5	0.19	3.8
NH <sub>3</sub>	Annual mean (1hr)	180	-	0.81973	0.43	-	-
Hg <sub>(ng/m3)</sub>	Annual mean (1hr)	250	0.038	0.0004	0.1	0.038	0.02
As <sub>(ng/m3)</sub>	Annual mean (1hr)	3	0.69	0.0000	0.2	0.69	23.0
Cr <sub>(ng/m3)</sub>	Annual mean (1hr)	5,000	-	0.0004	0.0	-	-
V <sup>3</sup>	Annual mean (1hr)	5	-	0.0004	0.0	-	-
Pb <sup>3</sup>	Annual mean (1hr)	0.25	0.01074	0.0004	0.2	0.011	4.4
Ni <sup>3</sup> <sub>(ng/m3)</sub>	Annual mean (1hr)	20	2.53	0.0004	2.0	2.53	12.65
Benzene <sup>4</sup>	Annual mean (1hr)	5	0.73	0.81973	16.39	1.550	30.99

Note All the above concentration figures are in µg/m<sup>3</sup> unless otherwise stated.

(ii) Short Term

Pollutant		EQS	Back-ground Conc	Process Contribution (PC)	PC as % of EQS	Predicted Environmental Concentration (PEC)	PEC as % EQS
HCl	Hourly maximum	750	0.828	1.5	0.2	2.328	0.31
HF	Hourly maximum	160	2.46	0.15	0.1	2.61	1.63
SO <sub>2</sub>	15-mins (99.9th %ile)	266	8.2	4.5	1.7	12.7	4.77
SO <sub>2</sub>	1-hour (99.73th %ile)	350	8.2	3.6	1.0	11.8	3.37
NO <sub>2</sub> <sup>(1)</sup>	1-hour (99.79th %ile)	200	55.6	3.0	1.5	58.6	29.3
PM10	24-hour (99.18th %ile)	50	-	0.23	0.5	-	-
SO <sub>2</sub>	24-hour (99.4th %ile)	125	24	1.7	1.4	25.7	20.56
CO	8-hour (100th %ile)	10000	-	5.3	0.1	-	-
NH <sub>3</sub>	Hourly maximum	2500	-	11.095	0.44	-	-
Hg <sub>(ng/m3)</sub>	Hourly maximum	7500	-	7.5	0.1	-	-
V	Hourly maximum	1	-	0.008	0.8	-	-

Note 1 All the above concentration figures are in µg/m<sup>3</sup> unless otherwise stated.

(i) Screening out emissions which are insignificant

From the tables above the following emissions can be screened out as insignificant in that the process contribution is < 1% of the long term EQS/EAL and <10% of the short term EAQ/EAL. These are:

*Long Term*

- PM<sub>10</sub>, HF, NH<sub>3</sub>, As, Pb, Cr and V

*Short Term*

- PM<sub>10</sub>, SO<sub>2</sub>, NH<sub>3</sub>, HCL, HF, CO, Hg, As, Cr, Pb and V

Therefore, generally, we consider the Applicant's proposals for preventing and minimising the emissions of these substances to be BAT for the Installation subject to the detailed audit referred to below.

(ii) Emissions unlikely to give rise to significant pollution

Also from the tables above the following emissions (which were not screened out as insignificant) have been assessed as being unlikely to give rise to significant pollution in that the predicted environmental concentration is less

than 100% (taking expected modelling uncertainties into account) of both the long term and short term EQS/EAL.

Long Term

- NO<sub>2</sub>, Cd, VOC's and Ni.

*Short Term*

- None

For these emissions, we have carefully scrutinised the Applicant's proposals to ensure that they are applying the Best Available Techniques to prevent and minimise emissions of these substances. This is reported in section 6 of this document.

#### 5.2.2 Consideration of key pollutants

(i) Nitrogen dioxide (NO<sub>2</sub>)

The impact on air quality from NO<sub>2</sub> emissions has been assessed against the EU EQS of 40 µg/m<sup>3</sup> as a long term annual average and a short term hourly average of 200 µg/m<sup>3</sup>. The model assumes a 100% NO<sub>x</sub> to NO<sub>2</sub> conversion for the long term and 50% for the short term assessment this represents a more conservative approach than recommended in Environment Agency guidance on the use of air dispersion modelling where 70% and 35% conversion rates are specified.

The above tables show that the peak long term PC is greater than 1% of the EUEQS and therefore cannot be screened out as insignificant. Even so, from the table above, the emission is not expected to result in the EUEQS being exceeded. The peak short term PC is marginally above the level we would consider insignificant (>10% of the EUEQS). However it is not expected to result in the EUEQS being exceeded.

(ii) Particulate matter PM<sub>10</sub> and PM<sub>2.5</sub>

The impact on air quality from particulate emissions has been assessed against the EQS for PM<sub>10</sub> (particles of 10 microns and smaller) and PM<sub>2.5</sub> (particles of 2.5 microns and smaller). For PM<sub>10</sub>, the EUEQS are a long term annual average of 40 µg/m<sup>3</sup> and a short term daily average of 50 µg/m<sup>3</sup>. For PM<sub>2.5</sub> the EUEQS of 25 µg/m<sup>3</sup> as a long-term annual average to be achieved by 2010 as a Target Value and by 2015 as a Limit Value has been used.

Pollutant	EQS	Back-ground Conc.	Process Contribution (PC)	PC as % of EQS	Predicted Environmental Concentration (PEC)	PEC as % EQS
<i>Long Term</i>						
PM <sub>10</sub>	40	16.4	0.07	0.2	16.47	41.175
PM <sub>2.5</sub>	20	11.19	0.07	0.2	11.26	56.300
<i>Short term</i>						
PM10	50	-	2.3197	4.64	-	-

The Applicant's maximum predicted impact of the Installation against these EQSs is shown in the tables above. The assessment assumes that particulate emissions are present as PM<sub>10</sub> for the PM<sub>10</sub> assessment and that all particulate emissions are present as PM<sub>2.5</sub> for the PM<sub>2.5</sub> assessment.

The above assessment is considered to represent a worst case assessment in that: -

- It assumes that the plant emits particulates continuously at the IED Annex VI limit for total dust, whereas actual emissions from similar plant are normally in the range 1 to 5 mg/m<sup>3</sup>.
- It assumes all particulates emitted are below 10 microns (PM<sub>10</sub>), when some are expected to be larger.

We have reviewed the Applicant's particulate matter impact assessment and are satisfied in the robustness of the Applicant's conclusions.

The above assessment shows that the predicted process contribution for emissions of PM<sub>10</sub> is below 10% of the short term EQS and so can be considered insignificant. The assessment is based very much on a worst case scenario, and in reality the process contribution is expected to be <1% of the EQS. Therefore, from the table above, the emission is not expected to result in the EQS being exceeded.

There is currently no emission limit prescribed nor any continuous emissions monitor for particulate matter specifically in the PM<sub>10</sub> or PM<sub>2.5</sub> fraction. Whilst the Environment Agency is confident that current monitoring techniques will capture the fine particle fraction (PM<sub>2.5</sub>) for inclusion in the measurement of total particulate matter, an improvement condition has been included that will require a full analysis of particle size distribution in the flue gas, and hence determine the ratio of fine to coarse particles. In the light of current knowledge and available data however the Environment Agency is satisfied that the health of the public would not be put at risk by such emissions.



(iii) Acid gases, SO<sub>2</sub>, HCl and HF

From the tables above, emissions of HCl and HF can be screened out as insignificant in that the process contribution is <10% of the short term EQS/EAL. There is no long term EQS/EAL for HCl. HF has 2 assessment criteria – a 1-hr EAL and a monthly EAL – the process contribution is <1% of the monthly EAL and so the emission is insignificant if the monthly EAL is interpreted as representing a long term EAL.

There is no long term EAL for SO<sub>2</sub> for the protection of human health. Protection of ecological receptors from SO<sub>2</sub> for which there is a long term EAL is considered in section 5.4.

Emissions of SO<sub>2</sub> can also be screened out as insignificant in that the short term process contribution is also <10% of each of the three short term EUEQS values. Therefore, generally, we consider the Applicant's proposals for preventing and minimising the emissions of these substances to be BAT for the Installation.

(iv) Emissions to Air of CO, VOCs, PAHs, PCBs, Dioxins and NH<sub>3</sub>

The Applicant has used the EQS for 1,3 butadiene for their assessment of the impact of VOC. This is based on 1,3 butadiene having the lowest EQS of organic species likely to be present in VOC (other than PAH, PCBs, dioxins and furans). The Applicant has also used the EQS for benzo[a]pyrene (BaP) for their assessment of the impact of PAH. We agree that the use of the BaP EQS is sufficiently precautionary.

There is no EAL for dioxins and furans as the principal exposure route for these substances is by ingestion and the risk to human health is through the accumulation of these substances in the body over an extended period of time. This issue is considered in more detail in section 5.3

From the tables above all the other emissions can be screened out as insignificant in that the process contribution is < 1% of the long term EQS/EAL and <10% of the short term EAQ/EAL.

The ammonia emission is based on a release concentration of 10 mg/m<sup>3</sup>. We are satisfied that this level of emission is consistent with the operation of a well controlled SNCR NO<sub>x</sub> abatement system.

Whilst all emissions cannot be screened out as insignificant, the Applicant's modelling shows that the installation is unlikely to result in a breach of the EAL. The Applicant is required to prevent, minimise and control PAH and VOC emissions using the best available techniques, this is considered further

in Section 6. We are satisfied that PAH and VOC emissions will not result in significant pollution.

Emission limits for ammonia (NH<sub>3</sub>) are not listed within the IED, the applicant has assumed a WCS emission concentration of 10mg/m<sup>3</sup> for NH<sub>3</sub> due to their SNCR NO<sub>x</sub> abatement.

In summary for the above emissions to air, we have carefully scrutinised the Applicant's proposals to ensure that they are applying the Best Available Techniques to prevent and minimise emissions of these substances. This is reported in section 6 of this document. Therefore, generally, we consider the Applicant's proposals for preventing and minimising the emissions of CO, NH<sub>3</sub>, PAHs and PCBs to be BAT for the Installation. Dioxins and furans are considered further in section 5.3.2.

### 5.2.3 Assessment of Emission of Metals

The Applicant has assessed the impact of metal emissions to air, as previously described.

Annex VI of IED sets three limits for metal emissions:

- An emission limit value of 0.05 mg/m<sup>3</sup> for mercury and its compounds (formerly WID group 1 metal).
- An aggregate emission limit value of 0.05 mg/m<sup>3</sup> for cadmium and thallium and their compounds (formerly WID group 2 metals).
- An aggregate emission limit of 0.5 mg/m<sup>3</sup> for antimony, arsenic, lead, chromium, cobalt, copper, manganese, nickel and vanadium and their compounds (formerly WID group 3 metals).

In addition the UK is a Party to the Heavy Metals Protocol within the framework of the UN-ECE Convention on long-range trans-boundary air pollution. Compliance with the IED Annex VI emission limits for metals along with the Application of BAT also ensures that these requirements are met.

Where Annex VI of the IED sets an aggregate limit, the Applicant's assessment assumes that for cadmium and thallium each metal is emitted individually at the aggregate limit value and for the other metals that each metal is emitted as the proportion of metals in its group (i.e. one ninth of the limit for each of the group 3 metals). Historical data for Municipal Waste Incinerators indicates that 1/9<sup>th</sup> of the limit is an over estimate of actual emissions, in addition this is a non-hazardous waste incinerator only so we are satisfied that the Applicant's proposal is reasonable in this context.

In section 5.2.1 above, the following emissions of metals were screened out as insignificant:

#### Long Term

- Sb, As, Cr, Co, Cu, Pb, Mn, Hg and V.

#### Short Term

- Sb, Cr, Cu, Mn, Hg and V.

Also in section 5.2.1, the following emissions of metals whilst not screened out as insignificant were assessed as being unlikely to give rise to significant pollution:

#### Long Term

- Cd and Ni

There were no metal emissions requiring further assessment. From this assessment the Applicant has concluded that exceedences of the EAL for all metals are not likely to occur. The installation has been assessed as meeting BAT for control of metal emissions to air. See section 6 of this document. The Environment Agency's experience of regulating incineration plant is that emissions of metals are in any event below the Annex VI limits set in IED, and that the above assessment is an over prediction of the likely impact.

### **Chromium (VI)**

The Expert Panel on Air Quality Standards (EPAQS) – “Guidelines for Metal and Metalloids in Ambient Air for the Protection of Human Health”, proposes new ambient air quality guidelines for Arsenic, Nickel and Chromium (VI). These guidelines have been incorporated as EALs in the revised H1 Guidance issued by the Agency in 2010. Arsenic, Nickel and Chromium are three of the nine Group 3 metals whose emissions are subject to a mandatory maximum emission limit by the IED. IED sets an aggregate limit of 0.5 mg/m<sup>3</sup> for all nine Group 3 metals. The EPAQS guidelines refer only to that portion of the metal emissions contained within PM<sub>10</sub> in ambient air. The new guidelines are 3ng/m<sup>3</sup> for Arsenic, 20ng/m<sup>3</sup> for Nickel and 0.2ng/m<sup>3</sup> for Chromium (VI). These are significantly lower than previous EALs. The IED limit for Group 3 metals of 0.5 mg/m<sup>3</sup> covers gaseous and vapour forms of the metals and their compounds as well as that present in particulate matter. IED has separate emission limit values for emissions to air of total particulate material. The EPAQS guideline also refers to Chromium (VI) only, whereas the Group 3 IED limit includes all Chromium. Measurement of Chromium (VI) at the levels anticipated at the stack emission points is expected to be difficult, with the likely levels being below the level of detection by the most advanced methods. We have considered the concentration of total chromium and chromium (VI) in

the APC residues collected upstream of the emission point for existing Municipal Waste incinerators and have assumed these to be similar to the particulate matter released from the emission point. This data shows:

- The mean proportion of Cr(VI) to total Cr is less than 1%. There are two outliers at 2%.
- The mean total Cr emission from these plants is 0.007 mg/m<sup>3</sup> (max 0.03 mg/m<sup>3</sup>).
- The mean Cr(VI) emission concentration (based on the bag dust ratio) is  $2.1 \times 10^{-5}$  mg/m<sup>3</sup> (max  $1.0 \times 10^{-4}$ ).

This data is remarkably self-consistent. Based on these data, we consider it remains a conservative assumption to consider that if the the maximum Cr(VI) emission concentration will be 0.0001 ng/m<sup>3</sup> for a Municipal waste incinerator then a waste wood incinerator would not be any higher..

Although the assessment shows that an exceedence of the EAL for Chromium (VI), emissions are likely to be low risk based on feedstock. The installation has been assessed as meeting BAT for control of metal emissions to air. See section 6 of this document.

#### 5.2.4 Consideration of Local Factors

##### (i) Impact on Air Quality Management Areas (AQMA)

As a result of our audit checks, we can agree with the Applicant's conclusion that the plant is not likely to lead to a significant contribution to any exceedence of EQS including the NO<sub>2</sub> impacts at the Nottingham Air Quality Management Areas (AQMA).

The Applicant's modelling predictions for the pollutants in the AQMA are summarised in the tables below. The figures shown indicate the predicted maximum peak ground level impact on pollutant concentrations in ambient air within the AQMA.

Pollutant	EQS	Back-ground Conc.	Process Contribution (PC)	PC as % of EQS	Predicted Environmental Concentration (PEC)	PEC as % EQS
PM <sub>10</sub>	40	16.4	0.07	0.58	16.47	41.175
NO <sub>2</sub>	40	20.8	3.0	7.5	28.3	70.75

Overall, whilst emissions cannot be screened out as insignificant, the Applicant's modelling shows that the installation is unlikely to result in a breach of the EUEQS within the AQMA.

The Applicant is required to prevent, minimise and control emissions using the best available techniques; this is considered further in Section 6.

### **5.3 Human health risk assessment**

#### **5.3.1 Our role in preventing harm to human health**

The Environment Agency has a statutory role to protect the environment and human health from all processes and activities it regulates. We assessed the effects on human health for this application in the following ways:

##### **i) Applying Statutory Controls**

The plant will be regulated under EPR. These regulations include the requirements of relevant EU Directives, notably, the industrial emissions directive (IED), the waste framework directive (WFD), and air quality directive (AQD).

The main conditions in an EfW permit are based on the requirements of the IED. Specific conditions have been introduced to specifically ensure compliance with the requirements of Chapter IV. The aim of the IED is to prevent or, where that is not practicable, to reduce emissions to air, water and land and prevent the generation of waste, in order to achieve a high level of protection of the environment taken as a whole. IED achieves this aim by setting operational conditions, technical requirements and emission limit values to meet the requirements set out in Articles 11 and 18 of the IED. These requirements include the application of BAT, which may in some circumstances dictate tighter emission limits and controls than those set out in Chapter IV of IED on waste incineration and co-incineration plants. The assessment of BAT for this installation is detailed in section 6 of this document.

##### **ii) Environmental Impact Assessment**

Industrial activities can give rise to odour, noise and vibration, accidents, fugitive emissions to air and water, releases to air (including the impact on Photochemical Ozone Creation Potential (POCP)), discharges to ground or groundwater, global warming potential and generation of waste. For an installation of this kind, the principal environmental effects are through emissions to air, although we also consider all of the other impacts listed. Section 5.1 and 5.2 above explain how we have approached the critical issue of assessing the likely impact of the emissions to air from the Installation on human health and the environment and any measures we are requiring to ensure a high level of protection.

### iii) Expert Scientific Opinion

We take account of the views of national and international expert bodies. Following is a summary of some of the publications which we have considered (in no particular order).

**Defra Report** An independent review of evidence on the health effects of municipal waste incinerators was published by **DEFRA** in 2004. It concluded that there was no convincing link between the emissions from MSW incinerators and adverse effects on public health in terms of cancer, respiratory disease or birth defects. On air quality effects, the report concluded “Waste incinerators contribute to local air pollution. This contribution, however, is usually a small proportion of existing background levels which is not detectable through environmental monitoring (for example, by comparing upwind and downwind levels of airborne pollutants or substances deposited to land). In some cases, waste incinerator facilities may make a more detectable contribution to air pollution. Because current MSW incinerators are located predominantly in urban areas, effects on air quality are likely to be so small as to be undetectable in practice.”

**HPA** A Position Statement issued by the **HPA** in 2009 states that “The Health Protection Agency has reviewed research undertaken to examine the suggested links between emissions from municipal waste incinerators and effects on health concludes “Modern, well managed incinerators make only a small contribution to local concentrations of air pollutants. It is possible that such small additions could have an impact on health but such effects, if they exist, are likely to be very small and not detectable.”. While it is not possible to rule out adverse health effects from modern, well regulated municipal waste incinerators with complete certainty, any potential damage to the health of those living close-by is likely to be very small, if detectable”.

**Policy Advice from Government** also points out that the minimal risk from modern incinerators. Paragraph 22 (Chapter 5) of WS2007 says that “research carried out to date has revealed no credible evidence of adverse health outcomes for those living near incinerators.” It points out that “the relevant health effects, mainly cancers, have long incubation times. But the research that is available shows an absence of symptoms relating to exposures twenty or more years ago when emissions from incinerators were much greater than is now the case.” **Paragraph 30 of PPS10** explains that “modern, appropriately located, well run and well regulated waste management facilities should pose little risk to public health.”

The **Committee on Carcinogenicity of Chemicals in Food, Consumer Products and the Environment (CoC)** issued a statement in 2000 which said that “any potential risk of cancer due to residency (for periods in excess of 10 years) near to municipal solid waste incinerators was exceedingly low and probably not measurable by the most modern epidemiological techniques.” In 2009, CoC considered six further relevant epidemiological papers that had been published since the 2000 statement, and concluded that

“there is no need to change the advice given in the previous statement in 2000 but that the situation should be kept under review”.

**Republic of Ireland Health Research Board** report stated that “It is hard to separate the influences of other sources of pollutants, and other causes of cancer and, as a result, the evidence for a link between cancer and proximity to an incinerator is not conclusive”.

The **Food Safety Authority of Ireland (FSAI) (2003)** investigated possible implications on health associated with food contamination from waste incineration and concluded: “In relation to the possible impact of introduction of waste incineration in Ireland, as part of a national waste management strategy, on this currently largely satisfactory situation, the FSAI considers that such incineration facilities, if properly managed, will not contribute to dioxin levels in the food supply to any significant extent. The risks to health and sustainable development presented by the continued dependency on landfill as a method of waste disposal far outweigh any possible effects on food safety and quality.”

**Health Protection Scotland (2009)** considered scientific studies on health effects associated with the incineration of waste particularly those published after the Defra review discussed earlier. The main conclusions of this report were: “(a) For waste incineration as a whole topic, the body of evidence for an association with (non-occupational) adverse health effects is both inconsistent and inconclusive. However, more recent work suggests, more strongly, that there may have been an association between emissions (particularly dioxins) in the past from industrial, clinical and municipal waste incinerators and some forms of cancer, before more stringent regulatory requirements were implemented. (b) For individual waste streams, the evidence for an association with (non-occupational) adverse health effects is inconclusive. (c) The magnitude of any past health effects on residential populations living near incinerators that did occur is likely to have been small. (d) Levels of airborne emissions from individual incinerators should be lower now than in the past, due to stricter legislative controls and improved technology. Hence, any risk to the health of a local population living near an incinerator, associated with its emissions, should also now be lower.”

The **US National Research Council Committee on Health Effects of Waste Incineration (NRC) (NRC 2000)** reviewed evidence as part of a wide ranging report. The Committee view of the published evidence was summarised in a key conclusion: “Few epidemiological studies have attempted to assess whether adverse health effects have actually occurred near individual incinerators, and most of them have been unable to detect any effects. The studies of which the committee is aware that did report finding health effects had shortcomings and failed to provide convincing evidence. That result is not surprising given the small populations typically available for study and the fact that such effects, if any, might occur only infrequently or take many years to appear. Also, factors such as emissions from other pollution sources and variations in human activity patterns often decrease the likelihood of determining a relationship between small contributions of

pollutants from incinerators and observed health effects. Lack of evidence of such relationships might mean that adverse health effects did not occur, but it could mean that such relationships might not be detectable using available methods and sources.”

The **British Society for Ecological Medicine (BSEM)** published a report in **2005** on the health effects associated with incineration and concluded that “Large studies have shown higher rates of adult and childhood cancer and also birth defects around municipal waste incinerators: the results are consistent with the associations being causal. A number of smaller epidemiological studies support this interpretation and suggest that the range of illnesses produced by incinerators may be much wider. Incinerator emissions are a major source of fine particulates, of toxic metals and of more than 200 organic chemicals, including known carcinogens, mutagens, and hormone disrupters. Emissions also contain other unidentified compounds whose potential for harm is as yet unknown, as was once the case with dioxins. Abatement equipment in modern incinerators merely transfers the toxic load, notably that of dioxins and heavy metals, from airborne emissions to the fly ash. This fly ash is light, readily windborne and mostly of low particle size. It represents a considerable and poorly understood health hazard.”

The BSEM report was reviewed by the HPA and they concluded that “Having considered the BSEM report the HPA maintains its position that contemporary and effectively managed and regulated waste incineration processes contribute little to the concentrations of monitored pollutants in ambient air and that the emissions from such plants have little effect on health.” The BSEM report was also commented on by the consultants who produced the Defra 2004 report referred to above. They said that “It fails to consider the significance of incineration as a source of the substances of concern. It does not consider the possible significance of the dose of pollutants that could result from incinerators. It does not fairly consider the adverse effects that could be associated with alternatives to incineration. It relies on inaccurate and outdated material. In view of these shortcomings, the report’s conclusions with regard to the health effects of incineration are not reliable.”

A **Greenpeace** review on incineration and human health concluded that a broad range of health effects have been associated with living near to incinerators as well as with working at these installations. Such effects include cancer (among both children and adults), adverse impacts on the respiratory system, heart disease, immune system effects, increased allergies and congenital abnormalities. Some studies, particularly those on cancer, relate to old rather than modern incinerators. However, modern incinerators operating in the last few years have also been associated with adverse health effects.”

The Health Protection Scotland report referred to above says that “the authors of the Greenpeace review do not explain the basis for their conclusion that there is an association between incineration and adverse effects in terms of criteria used to assess the strength of evidence. The weighting factors used to derive the assessment are not detailed. The objectivity of the conclusion cannot therefore be easily tested.”



From this published body of scientific opinion, we take the view stated by the HPA that “While it is not possible to rule out adverse health effects from modern, well regulated municipal waste incinerators with complete certainty, any potential damage to the health of those living close-by is likely to be very small, if detectable”. We therefore ensure that permits contain conditions which require the installation to be well-run and regulate the installation to ensure compliance with such permit conditions.

#### iv) Health Risk Models

Comparing the results of air dispersion modelling as part of the H1 Environmental Impact assessment against European and national air quality standards effectively makes a health risk assessment for those pollutants for which a standard has been derived. These air quality standards have been developed primarily in order to protect human health via known intake mechanisms, such as inhalation and ingestion. Some pollutants, such as dioxins and furans, have human health impacts at lower ingestion levels than lend themselves to setting an air quality standard to control against. For these pollutants, a different human health risk model is required which better reflects the level of dioxin intake.

**Dioxin Intake Models:** Two models are available to predict the dioxin intake for comparison with the Tolerable Daily Intake (TDI) recommended by the Committee on Toxicity of Chemicals in Food, Consumer Products and the Environment, known as COT. These are HHRAP and the HMIP model.

HHRAP has been developed by the US EPA to calculate the human body intake of a range of carcinogenic pollutants and to determine the mathematic quantitative risk in probabilistic terms. In the UK, in common with other European Countries, we consider a threshold dose below which the likelihood of an adverse effect is regarded as being very low or effectively zero. The HMIP model uses a similar approach to the HHRAP model, but does not attempt to predict probabilistic risk. Either model can however be used to make comparisons with the TDI.

The TDI is the amount of a substance that can be ingested daily over a lifetime without appreciable health risk. It is expressed in relation to bodyweight in order to allow for different body size, such as for children of different ages. In the UK, the COT has set a TDI for dioxins and furans of 2 picograms I-TEQ/Kg-body weight/day (N.B. a picogram is a million millionths ( $10^{-12}$ ) of a gram).

In addition to an assessment of risk from dioxins and furans, the HHRAP model enables a risk assessment from human intake of a range of heavy metals. The HMIP report does not consider metals. In principle, the respective EQS for these metals are protective of human health. It is not therefore necessary to model the human body intake.

COMEAP developed a methodology based on the results of time series epidemiological studies which allows calculation of the public health impact of exposure to the classical air pollutants (NO<sub>2</sub>, SO<sub>2</sub> and particulates) in terms of the numbers of “deaths brought forward” and the “number of hospital admissions for respiratory disease brought forward or additional”. COMEAP has issued a statement expressing some reservations about the applicability of applying its methodology to small affected areas. Those concerns generally relate to the fact that the exposure-response coefficients used in the COMEAP report derive from studies of whole urban populations where the air pollution climate may differ from that around a new industrial installation. COMEAP identified a number of factors and assumptions that would contribute to the uncertainty of the estimates. These were summarised in the Defra review as below:

- Assumption that the spatial distribution of the air pollutants considered is the same in the area under study as in those areas, usually cities or large towns, in which the studies which generated the coefficients were undertaken.
- Assumption that the temporal pattern of pollutant concentrations in the area under study is similar to that in the areas in which the studies which generated the coefficients were undertaken (i.e. urban areas).
- It should be recognised that a difference in the pattern of socio-economic conditions between the areas to be studied and the reference areas could lead to inaccuracy in the predicted level of effects.
- In the same way, a difference in the pattern of personal exposures between the areas to be studied and the reference areas will affect the accuracy of the predictions of effects.

The use of the COMEAP methodology is not generally recommended for modelling the human health impacts of individual installations. However it may have limited applicability where emissions of NO<sub>x</sub>, SO<sub>2</sub> and particulates cannot be screened out as insignificant in an H1 Environmental Impact assessment, there are high ambient background levels of these pollutants and we are advised that its use was appropriate by our public health consultees.

Our recommended approach is therefore the use of the H1 assessment methodology comparison for most pollutants (including metals) and dioxin intake models using either the HHRA or HMIP models as described above for dioxins and furans. Where an alternative approach is adopted for dioxins, we check the predictions ourselves using the HMIP methodology.

## **v) Consultations**

As part of our normal procedures for the determination of a permit application, we would consult PCT (England), FSA and in some cases HPA. In this case the PCT also consulted with the HPA. All issues raised by these consultations are considered in determining the application as described in Annex 4 of this document.

### 5.3.2 Assessment of Intake of Dioxins and Furans

For dioxins and furans, the principal exposure route is through ingestion, usually through the food chain, and the main risk to health is through accumulation in the body over a period of time.

The human health risk assessment calculates the dose of dioxins and furans that would be received by local receptors if all their food and water were sourced from the locality where the deposition of dioxins and furans is predicted to be the highest. This is then assessed against the Tolerable Daily Intake (TDI) levels established by the COT of 2 picograms I-TEQ / Kg bodyweight/ day.

The results of the Applicant's assessment of dioxin intake are detailed in the table below. The results showed that the predicted daily intake of dioxins at all receptors, resulting from emissions from the proposed facility, were below the recommended TDI levels. Given the assumptions in the impact modelling and the application of BAT for minimising dioxin emissions, it is unlikely that the TDI would be exceeded due to the proposed plant's emissions.

<b>Receptor</b>	<b>adult</b>	<b>child</b>
Maximum Exposed individual	0.044 (2.2% of TDI)	0.077 (3.9% of TDI)

Calculated maximum daily intake of dioxins by local receptors resulting from the operation of the proposed facility (I-TEQ/ kg-BW/day)

The FSA has reported that dietary studies have shown that estimated total dietary intakes of dioxins and dioxin-like PCBs from all sources by all age groups fell by around 50% between 1997 and 2001, and are expected to continue to fall. In 2001, the average daily intake by adults in the UK from diet was 0.9 pg WHO-TEQ/kg bodyweight. The additional daily intake predicted by the modelling as shown in the table above is substantially below this figure.

In 2010, FSA studied the levels of chlorinated, brominated and mixed (chlorinated-brominated) dioxins and dioxin-like PCBs in fish, shellfish, meat and eggs consumed in UK. It asked COT to consider the results and to advise on whether the measured levels of these PXDDs, PXDFs and PXBs indicated a health concern ('X' means a halogen). COT issued a statement in December 2010 and concluded that "The major contribution to the total dioxin toxic activity in the foods measured came from chlorinated compounds. Brominated compounds made a much smaller contribution, and mixed halogenated compounds contributed even less (1% or less of TDI). Measured levels of PXDDs, PXDFs and dioxin-like PXBs do not indicate a health concern". COT recognised the lack of quantified TEFs for these compounds but said that "even if the TEFs for PXDDs, PXDFs and dioxin-like PXBs were up to four fold higher than assumed, their contribution to the total TEQ in the diet would still be small. Thus, further research on PXDDs, PXDFs and dioxin-like PXBs is not considered a priority."

In the light of this statement, we assess the impact of chlorinated compounds as representing the impact of all chlorinated, brominated and mixed dioxins / furans and dioxin like PCBs.

### 5.3.3 Particulates smaller than 2.5 microns

The Operator will be required to monitor particulate emissions using the method set out in Table S3.1 of Schedule 3 of the Permit. This method requires that the filter efficiency must be at least 99.5 % on a test aerosol with a mean particle diameter of 0.3  $\mu\text{m}$ , at the maximum flow rate anticipated. The filter efficiency for larger particles will be at least as high as this. This means that particulate monitoring data effectively captures everything above 0.3  $\mu\text{m}$  and much of what is smaller. It is not expected that particles smaller than 0.3  $\mu\text{m}$  will contribute significantly to the mass release rate / concentration of particulates because of their very small mass, even if present. This means that emissions monitoring data can be relied upon to measure the true mass emission rate of particulates.

Nano-particles are considered to refer to those particulates less than 0.1  $\mu\text{m}$  in diameter ( $\text{PM}_{0.1}$ ). Questions are often raised about the effect of nano-particles on human health, in particular on children's health, because of their high surface to volume ratio, making them more reactive, and their very small size, giving them the potential to penetrate cell walls of living organisms. The small size also means there will be a larger number of small particles for a given mass concentration. However the HPA statement (referenced below) says that due to the small effects of incinerators on local concentration of particles, it is highly unlikely that there will be detectable effects of any particular incinerator on local infant mortality.

The HPA addresses the issue of the health effects of particulates in their September 2009 statement 'The Impact on Health of Emissions to Air from Municipal Incinerators'. It refers to the coefficients linking  $\text{PM}_{10}$  and  $\text{PM}_{2.5}$  with effects on health derived by COMEAP and goes on to say that if these coefficients are applied to small increases in concentrations produced, locally, by incinerators; the estimated effects on health are likely to be small. The HPA notes that the coefficients that allow the use of number concentrations in impact calculations have not yet been defined because the national experts have not judged that the evidence is sufficient to do so. This is an area being kept under review by COMEAP.

In December 2010, COMEAP published a report on The Mortality Effects of Long-Term Exposure to Particulate Air Pollution in the United Kingdom. It says that "a policy which aims to reduce the annual average concentration of  $\text{PM}_{2.5}$  by 1  $\mu\text{g}/\text{m}^3$  would result in an increase in life expectancy of 20 days for people born in 2008." However, "The Committee stresses the need for careful interpretation of these metrics to avoid incorrect inferences being drawn – they are valid representations of population aggregate or average effects, but they can be misleading when interpreted as reflecting the experience of individuals."

The HPA also point out that in 2007 incinerators contributed 0.02% to ambient ground level PM<sub>10</sub> levels compared with 18% for road traffic and 22% for industry in general. The HPA note that in a sample collected in a day at a typical urban area the proportion of PM<sub>0.1</sub> is around 5-10% of PM<sub>10</sub>. It goes on to say that PM<sub>10</sub> includes and exceeds PM<sub>2.5</sub> which in turn includes and exceeds PM<sub>0.1</sub>.

We take the view, based on the foregoing evidence, that techniques which control the release of particulates to levels which will not cause harm to human health will also control the release of fine particulate matter to a level which will not cause harm to human health.

#### 5.3.4 Assessment of Health Effects from the Installation

We have assessed the health effects from the operation of this installation in relation to the above (sections 5.3.1 to 5.3.3). We have applied the relevant requirements of the national and European legislation in imposing the permit conditions. We are satisfied that compliance with these conditions will ensure protection of the environment and human health.

Taking into account all of the expert opinion available, we agree with the conclusion reached by the HPA that “While it is not possible to rule out adverse health effects from modern, well regulated municipal waste incinerators with complete certainty, any potential damage to the health of those living close-by is likely to be very small, if detectable.”

In carrying out air dispersion modelling as part of the H1 Environmental Impact assessment and comparing the predicted environmental concentrations with European and national air quality standards, the Applicant has effectively made a health risk assessment for many pollutants. These air quality standards have been developed primarily in order to protect human health.

The Environment Agency has reviewed the methodology employed by the Applicant to carry out the health impact assessment.

The applicant’s precise values for human intake of dioxins, furans and dioxin-like PCB’s can only be used for highly conservative screening.

Overall, taking into account the conservative nature of the impact assessment (i.e. that it is based upon an individual exposed for a life-time to the effects of the highest predicted airborne concentrations and consuming mostly locally grown food), it was concluded that the operation of the proposed facility will not pose a significant carcinogenic or non-carcinogenic risk to human health. Public Health England and Food Standards Agency were consulted on the Application and concluded that they had no significant concerns regarding the risk to the health of humans from the installation. The Food Standards Agency was also consulted during the permit determination process and it concluded that it is unlikely that there will be any unacceptable effects on the human food chain as a result of the operations at the Installation. Details of the responses

provided by the HSE, Public Health England, Planning Authority and National Grid to the consultation on this Application can be found in Annex 2.

The Environment Agency is therefore satisfied that the Applicant's conclusions presented above are soundly based and we conclude that the potential emissions of pollutants including dioxins, furans and metals from the proposed facility are unlikely to have an impact upon human health.

#### **5.4 Impact on Habitats sites, SSSIs, non-statutory conservation sites etc.**

##### 5.4.1 Sites Considered

There are no Habitats (i.e. Special Areas of Conservation, Special Protection Areas and Ramsar) sites within 10Km of the proposed Installation.

There are two Sites of Special Scientific Interest within 2Km of the proposed Installation.

- Sellers Wood SSSI
- Bulwell Wood SSSI

The following non-statutory local wildlife and conservation sites are located within 2Km of the Installation.

- Bulwell Hall Park Meadows LNR
- Bulwell Hall LNR
- Moorbridge Pond pLNR
- Hucknall Road pLNR
- Starth Wood SINC
- Hucknell Airfield SINC
- Bulwell Wood and Pond SINC
- New Farm Wood SINC
- Kimberley Cutting SINC
- Newlane Pastures SINC
- Nuthall Cutting SINC
- Blenheim Lane Ponds SINC
- Blenheim Lane Grasslands SINC
- Blenheim Lane Hedgerows SINC
- Farley Disused Railway Blenheim Lane Ponds SINC
- High Wood SINC
- Snape Wood SINC
- River Lean SINC
- Bulwell Forest Golf Course SINC

##### 5.4.2 Assessment of SSSIs and Non-Statutory Sites

The Applicant submitted collected data on the aerial emissions that would be generated by the proposed development and modelling was undertaken

which showed that for all pollutants (NO<sub>x</sub>, SO<sub>2</sub>, NH<sub>3</sub>, N deposition and acid deposition), compared to all critical levels at all statutory receptors and below the 1% significance criterion at the two SSSIs and the process contribution (PC) did not exceed 100% of any relevant Critical Level or Critical load.

#### Critical Levels

##### Maximum PC at any Receptor

Pollutant	EQS	PC	%EQS	BC	PEC
NO <sub>2</sub>	30	0.52	1.7	22.29	22.81
SO <sub>2</sub>	20	0.24	1.2	12	12.24
NH <sub>3</sub>	3	0.63	21.12	1.25	1.88

#### Critical Loads

##### Calculated total N deposition

For all modelled receptors the Process Contribution is <100% of the relevant Critical Load function and is therefore not significant.

##### Calculated total acid deposition

For all modelled receptors the Process Contribution is <100% of the relevant Critical Load function and is therefore not significant.

The Applicant has not specified whether the ammonia critical level at both Bulwell Wood and Sellers Wood should be 1µg/m<sup>3</sup> or 3µg/m<sup>3</sup>. Assuming the lower critical level, the Applicant's predictions indicate a PC of 1.6% with PEC of 89.6% at Sellers Wood and a PC of 1.1% and a PEC of 89.1% at Bulwell Wood. The Applicant has used a background value of 0.883µg/m<sup>3</sup>, which they have obtained from the annual average at Ladybower 2013. Apis however suggests background values which are higher and could lead to the PEC exceeding 100% of the critical level. Given the lower level, these predictions would be candidates for potential significant impacts that would require consultation. The Applicant predicts PCs that are below the 100% significance criterion for all other sites compared to the critical levels. At the two SSSIs they predict exceedences of the insignificance criteria compared to the nutrient nitrogen critical loads (i.e. >1%). The nutrient nitrogen deposition background from Apis shows the background has already exceeded the critical load of 15kgN/ha/yr. They present their acid depositions (including the contribution from NH<sub>3</sub> and hydrogen chloride HCl). For HCl, the Environment Agency's factor of 3 is used to convert from dry deposition to total (wet + dry).

For all sites with respect to nutrient nitrogen and acid critical loads, we have checked the critical load values from source data used and are satisfied that they are representative.

There are no point source emissions to water, land

A full assessment of the application and its potential to affect the site(s) habitat has been carried out as part of the permitting process. We consider that the application will not affect the features of the site/species/habitat

We have not formally consulted on the application. The decision was taken in accordance with our guidance.

## **5.5 Impact of abnormal operations**

Article 50(4)(c) of IED requires that waste incineration and co-incineration plants shall operate an automatic system to prevent waste feed whenever any of the continuous emission monitors show that an emission limit value (ELV) is exceeded due to disturbances or failures of the purification devices. Notwithstanding this, Article 46(6) allows for the continued incineration and co-incineration of waste under such conditions provided that this period does not (in any circumstances) exceed 4 hours uninterrupted continuous operation or the cumulative period of operation does not exceed 60 hours in a calendar year. This is a recognition that the emissions during transient states (e.g. start-up and shut-down) are higher than during steady-state operation, and the overall environmental impact of continued operation with a limited exceedance of an ELV may be less than that of a partial shut-down and re-start.

For incineration plant, IED sets backstop limits for particulates, CO and TOC which must continue to be met at all times, The CO and TOC limits are the same as for normal operation, and are intended to ensure that good combustion conditions are maintained. The backstop limit for particulates is  $150 \text{ mg/m}^3$  (as a half hourly average) which is five times the limit in normal operation. However, the Applicant considered that this allowance of five times the normal limit was not required or appropriate for their plant operation, and did not assess the potential environmental impacts at the higher short term level in their Application. Therefore, the abnormal ELV set in Table S3.1(a) has been set at the normal level of  $30 \text{ mg/m}^3$ .

Article 45(1)(f) requires that the permit shall specify the maximum permissible period of any technically unavoidable stoppages, disturbances, or failures of the purification devices or the measurement devices, during which the concentrations in the discharges into the air may exceed the prescribed emission limit values. In this case we have decided to set the time limit at 4 hours, which is the maximum period prescribed by Article 46(6).

Given that these abnormal operations are limited to no more than a period of 4 hours continuous operation and no more than 60 hour aggregated operation in any calendar year. This is less than 1% of total operating hours and so abnormal operating conditions are not expected to have any significant long term environmental impact unless the background conditions were already close to, or exceeding, an EQS. For the most part therefore consideration of



abnormal operations is limited to consideration of its impact on short term EQSs.

In making an assessment of abnormal operations the following worst case scenario has been assumed – It should be noted that modelling and assessment of this worst case scenario was only carried out by the Environment Agency and not by the Applicant:

- Particulate emissions of 150 mg/m<sup>3</sup> (15 x normal)
- TOC emissions of 20mg/m<sup>3</sup> (2x normal)
- CO emissions of 200mg/m<sup>3</sup> (4x normal)

This is a worst case scenario in that these abnormal conditions include a number of different equipment failures not all of which will necessarily result in an adverse impact on the environment (e.g. a failure of a monitoring instrument does not necessarily mean that the incinerator or abatement plant is malfunctioning). This analysis assumes that any failure of any equipment results in all the negative impacts set out above occurring simultaneously.

The result on the Applicant’s short-term environmental impact is summarised in the table below.

Pollutant	Averaging period	ES (µg/m <sup>3</sup> )	PC (µg/m <sup>3</sup> )	%ES
PM10	hourly mean	50 <sup>1</sup>	38.98	77.96
CO	8 hour mean	10,000	26.22	0.26

1: Is specified as a 24 hour mean not to be exceeded more than 35 times per year (90.41%ile)

From the table above the emissions of the following substances can still be considered insignificant, in that the PC is still <10% of the short-term EQS/EAL

- CO

Also from the table above emissions of the following emissions (which were not screened out as insignificant) have been assessed as being unlikely to give rise to significant pollution in that the predicted environmental concentration is less than 100% of short term EQS/EAL.

- PM10

The maximum predicted short-term ground level concentration of PM10, as an hourly mean, assuming continuous abnormal emissions is 39 µg/m<sup>3</sup>. This can not be directly compared to the EAL of 50µg/m<sup>3</sup> as this is specified as a 24 hour mean which is not to be exceeded more than 35 times per year.

We are therefore satisfied that it is not necessary to further constrain the conditions and duration of the periods of abnormal operation beyond those permitted under Chapter IV of the IED.

We have not assessed the impact of abnormal operations against long term EQSs for the reasons set out above. Except that if dioxin emissions were at 10 ng/m<sup>3</sup> for the maximum period of abnormal operation, this would result in an increase of approximately 70% in the TDI reported in section 5.3.2. In these circumstances the TDI would be still be below 2 pg(I-TEQ/ kg-BW/day), of the COT TD and will still not pose a risk to human health.

## 6. Application of Best Available Techniques

### 6.1 Scope of Consideration

In this section, we explain how we have determined whether the Applicant's proposals are the Best Available Techniques for this Installation.

- The first issue we address is the fundamental choice of incineration technology. There are a number of alternatives, and the Applicant has explained why it has chosen one particular kind for this Installation.

We then consider in particular control measures for the emissions which were not screened out as insignificant in the previous section on minimising the installation's environmental impact. They are: NO<sub>2</sub>, Cd, Ni (Long Term).

- We also have to consider the combustion efficiency and energy utilisation of different design options for the Installation, which are relevant considerations in the determination of BAT for the Installation, including the Global Warming Potential of the different options.
- Finally, the prevention and minimisation of Persistent Organic Pollutants (POPs) must be considered, as we explain below.

Chapter IV of the IED specifies a set of maximum emission limit values. Although these limits are designed to be stringent, and to provide a high level of environmental protection, they do not necessarily reflect what can be achieved by new plant. Article 14(3) of the IED says that BAT conclusions shall be the reference for setting the permit conditions, so it may be possible and desirable to achieve emissions below the limits referenced in Chapter IV.

Even if the Chapter IV limits are appropriate, operational controls complement the emission limits and should generally result in emissions below the maximum allowed; whilst the limits themselves provide headroom to allow for unavoidable process fluctuations. Actual emissions are therefore almost certain to be below emission limits in practice, because any Operator who sought to operate its installation continually at the maximum permitted level would almost inevitably breach those limits regularly, simply by virtue of normal fluctuations in plant performance, resulting in enforcement action

(including potentially prosecution) being taken. Assessments based on, say, Chapter IV limits are therefore “worst-case” scenarios.

Should the Installation, once in operation, emit at rates significantly below the limits included in the Permit, we will consider tightening ELVs appropriately. We are, however, satisfied that emissions at the permitted limits would ensure a high level of protection for human health and the environment in any event.

#### 6.1.1 Consideration of Furnace Type

The prime function of the furnace is to achieve maximum combustion of the waste. Chapter IV of the IED requires that the plant (furnace in this context) should be designed to deliver its requirements. The main requirements of Chapter IV in relation to the choice of a furnace are compliance with air emission limits for CO and TOC and achieving a low TOC/LOI level in the bottom ash.

The Waste Incineration BREF elaborates the furnace selection criteria as:

- the use of a furnace (including secondary combustion chamber) dimensions that are large enough to provide for an effective combination of gas residence time and temperature such that combustion reactions may approach completion and result in low and stable CO and TOC emissions to air and low TOC in residues.
- use of a combination of furnace design, operation and waste throughput rate that provides sufficient agitation and residence time of the waste in the furnace at sufficiently high temperatures.
- The use of furnace design that, as far as possible, physically retain the waste within the combustion chamber (e.g. grate bar spacing) to allow its complete combustion.

The BREF also provides a comparison of combustion and thermal treatment technologies and factors affecting their applicability and operational suitability used in EU and for all types of wastes. There is also some information on the comparative costs. The table below has been extracted from the BREF tables. This table is also in line with the Guidance Note “The Incineration of Waste (EPR 5.01)). However, it should not be taken as an exhaustive list nor that all technologies listed have found equal application across Europe.

Overall, any of the furnace technologies listed below would be considered as BAT provided the Applicant has justified it in terms of:

- nature/physical state of the waste and its variability
- proposed plant throughput which may affect the number of incineration lines
- preference and experience of chosen technology including plant availability
- nature and quantity/quality of residues produced.
- emissions to air – usually NO<sub>x</sub> as the furnace choice could have an effect on the amount of unabated NO<sub>x</sub> produced

- energy consumption – whole plant, waste preparation, effect on GWP
- Need, if any, for further processing of residues to comply with TOC
- Costs

**Summary comparison of thermal treatment technologies (reproduced from the Waste Incineration BREF)**

Technique	Key waste characteristics and suitability	Throughput per line	Advantages	Disadvantages / Limitations of use	Bottom Ash Quality	Cost
Moving grate (air-cooled)	<p>Low to medium heat values (LCV 5 – 16.5 GJ/t)</p> <p>Municipal and other heterogeneous solid wastes</p> <p>Can accept a proportion of sewage sludge and/or medical waste with municipal waste</p> <p>Applied at most modern MSW installations</p>	<p>1 to 50 t/h with most projects 5 to 30 t/h.</p> <p>Most industrial applications not below 2.5 or 3 t/h.</p>	<p>Widely proven at large scales.</p> <p>Robust</p> <p>Low maintenance cost</p> <p>Long operational history</p> <p>Can take heterogeneous wastes without special preparation</p>	<p>generally not suited to powders, liquids or materials that melt through the grate</p>	<p>TOC 0.5 % to 3 %</p>	<p>High capacity reduces specific cost per tonne of waste</p>
Moving grate (liquid Cooled)	<p>Same as air-cooled grates except:</p> <p>LCV 10 – 20 GJ/t</p>	<p>Same as air-cooled grates</p>	<p>As air-cooled grates but: waste treatable better</p> <p>Combustion control possible.</p>	<p>As air-cooled grates but: risk of grate damaging leaks and <input type="checkbox"/> higher complexity</p>	<p>TOC 0.5 % to 3 %</p>	<p>Slightly higher capital cost than air-cooled</p>

Technique	Key waste characteristics and suitability	Throughput per line	Advantages	Disadvantages / Limitations of use	Bottom Ash Quality	Cost
Rotary Kiln	Can accept liquids and pastes <input type="checkbox"/> more limited than grate (owing to refractory damage) <input type="checkbox"/> <input type="checkbox"/> <input type="checkbox"/> applied to hazardous Wastes	<10 t/h	Very well proven with <input type="checkbox"/> <input type="checkbox"/> broad range of wastes and <input type="checkbox"/> out even of HW	Throughputs lower than grates	TOC <3 %	Higher specific cost due to reduced capacity
Fluid bed - bubbling	Only finely divided consistent wastes.  Limited use for raw MSW <input type="checkbox"/> often applied to sludges	1 to 10 t/h	Good mixing  Fly ashes of good leaching quality	Careful operation required to avoid clogging bed.  Higher fly ash quantities.	TOC <3 %	FGT cost may be lower.  Costs of waste preparation
Fluid bed - circulating	Only finely divided consistent wastes.  Limited use for raw MSW, often applied to sludges / RDF.	1 to 20 t/h most used above 10 t/h	Greater fuel flexibility than BFB  Fly ashes of good leaching quality	Cyclone required to conserve bed material  Higher fly ash quantities	TOC <3 %	FGT cost may be lower.  Costs of preparation.
Oscillating furnace	MSW / wastes <input type="checkbox"/>	1 – 10 t/h	Robust Low maintenance Long history <input type="checkbox"/> <input type="checkbox"/> Low NOX level Low LOI of bottom ash	-higher thermal loss than with grate furnace - LCV under 15 GJ/t	TOC 0.5 – 3 %	Similar to other technologies

Technique	Key waste characteristics and suitability	Throughput per line	Advantages	Disadvantages / Limitations of use	Bottom Ash Quality	Cost
Pulsed hearth	Only higher CV waste (LCV >20 GJ/t) <input type="checkbox"/> used for clinical wastes	<7 t/h	can deal with liquids and powders	bed agitation may be lower	Dependent on waste type	Higher specific cost due to reduced capacity
Stepped and static hearths	Only higher CV waste (LCV >20 GJ/t)  Mainly used for clinical wastes	No information	Can deal with liquids and powders	Bed agitation may be lower	Dependent on waste type	Higher specific cost due to reduced capacity
Spreader - stoker combustor	- RDF and other particle feeds <input type="checkbox"/> <input type="checkbox"/> poultry manure <input type="checkbox"/> <input type="checkbox"/> wood wastes	No information	- simple grate construction <input type="checkbox"/> <input type="checkbox"/> less sensitive to particle size than FB	only for well defined mono-streams	No information	No information
Gasification - fixed bed	- mixed plastic wastes <input type="checkbox"/> <input type="checkbox"/> other similar consistent streams <input type="checkbox"/> <input type="checkbox"/> gasification less widely used/proven than incineration	1 to 20 t/h	-low leaching residue <input type="checkbox"/> <input type="checkbox"/> <input type="checkbox"/> good burnout if oxygen blown <input type="checkbox"/> <input type="checkbox"/> syngas available -Reduced oxidation of recyclable metals	- limited waste feed - not full combustion - high skill level <input type="checkbox"/> <input type="checkbox"/> tar in raw gas - less widely proven	-Low leaching bottom ash <input type="checkbox"/> <input type="checkbox"/> good burnout with oxygen	High operation/maintenance costs

Technique	Key waste characteristics and suitability	Throughput per line	Advantages	Disadvantages / Limitations of use	Bottom Ash Quality	Cost
Gasification - entrained flow	- mixed plastic wastes - other similar consistent streams <input type="checkbox"/> <input type="checkbox"/> <input type="checkbox"/> not suited to untreated MSW <input type="checkbox"/> <input type="checkbox"/> <input type="checkbox"/> gasification less widely used/proven than incineration	To 10 t/h	- low leaching slag <input type="checkbox"/> <input type="checkbox"/> reduced oxidation of recyclable metals	- limited waste feed <input type="checkbox"/> <input type="checkbox"/> not full combustion <input type="checkbox"/> <input type="checkbox"/> high skill level <input type="checkbox"/> <input type="checkbox"/> less widely proven	low leaching slag	High operation/maintenance costs pre-treatment costs high
Gasification - fluid bed	- mixed plastic wastes <input type="checkbox"/> <input type="checkbox"/> shredded MSW <input type="checkbox"/> <input type="checkbox"/> shredder residues <input type="checkbox"/> <input type="checkbox"/> <input type="checkbox"/> sludges <input type="checkbox"/> <input type="checkbox"/> metal rich wastes <input type="checkbox"/> <input type="checkbox"/> other similar consistent streams <input type="checkbox"/> less widely used/proven than incineration	5 – 20 t/h	-temperatures e.g. for Al recovery <input type="checkbox"/> <input type="checkbox"/> separation of non combustibles -can be combined with ash melting - reduced oxidation of recyclable metals	-limited waste size (<30cm) - tar in raw gas - higher UHV raw gas - less widely proven	If Combined with ash melting chamber ash is vitrified	Lower than other gasifiers
Pyrolysis	<input type="checkbox"/> <input type="checkbox"/> pre-treated MSW <input type="checkbox"/> <input type="checkbox"/> high metal inert streams <input type="checkbox"/> <input type="checkbox"/> shredder residues/plastics <input type="checkbox"/> <input type="checkbox"/> pyrolysis is less widely used/proven than incineration	~ 5 t/h (short drum) 5 – 10 t/h (medium drum)	<input type="checkbox"/> no oxidation of metals <input type="checkbox"/> <input type="checkbox"/> no combustion energy for metals/inert <input type="checkbox"/> <input type="checkbox"/> in reactor acid neutralisation possible <input type="checkbox"/> <input type="checkbox"/> syngas available	- limited wastes <input type="checkbox"/> <input type="checkbox"/> process control and engineering critical <input type="checkbox"/> <input type="checkbox"/> high skill req. <input type="checkbox"/> <input type="checkbox"/> not widely proven <input type="checkbox"/> <input type="checkbox"/> need market for syngas	- dependent on process temperature <input type="checkbox"/> residue produced requires further processing e.g. combustion	High pre-treatment, operation and capital costs



Applicant's Justification.  
Boiler Design

In accordance with our Technical Guidance Note, S5.01, the Applicant has confirmed that the boiler design will include the following features to minimise the potential for reformation of dioxins within the de-novo synthesis range:

- ensuring that the steam/metal heat transfer surface temperature is a minimum where the exhaust gases are within the de-novo synthesis range;
- design of the boilers using CFD to ensure no pockets of stagnant or low velocity gas;
- boiler passes are progressively decreased in volume so that the gas velocity increases through the boiler; and
- Design of boiler surfaces to prevent boundary layers of slow moving gas.

We have considered the assessments made by the Applicant and agree that the furnace technology chosen represents BAT. Any of the options listed in the BREF and summarised in the table above can be BAT. The Applicant has chosen a furnace technique that is listed in the BREF and we are satisfied that the Applicant has provided sufficient justification to show that their technique is BAT. This is not to say that the other techniques could not also be BAT, but that the Applicant has shown that their chosen technique is at least comparable with the other BAT options. We believe that, based on the information gathered by the BREF process, the chosen technology will achieve the requirements of Chapter IV of the IED for the air emission of TOC/CO and the TOC on bottom ash.

## 6.2 BAT and emissions control

The prime function of flue gas treatment is to reduce the concentration of pollutants in the exhaust gas as far as practicable. The techniques which are described as BAT individually are targeted to remove specific pollutants, but the BREF notes that there is benefit from considering the FGT system as a whole unit. Individual units often interact, providing a primary abatement for some pollutants and an additional effect on others.

The BREF lists the general factors requiring consideration when selecting flue-gas treatment (FGT) systems as:

- type of waste, its composition and variation
- type of combustion process, and its size
- flue-gas flow and temperature
- flue-gas content, size and rate of fluctuations in composition
- target emission limit values
- restrictions on discharge of aqueous effluents
- plume visibility requirements
- land and space availability
- availability and cost of outlets for residues accumulated/recovered
- compatibility with any existing process components (existing plants)
- availability and cost of water and other reagents

- energy supply possibilities (e.g. supply of heat from condensing scrubbers)
- reduction of emissions by primary methods
- release of noise.

Taking these factors into account the Technical Guidance Note points to a range of technologies being BAT subject to circumstances of the Installation.

### 6.2.1 Particulate Matter

<b>Particulate matter</b>				
<b>Technique</b>	<b>Advantages</b>	<b>Disadvantages</b>	<b>Optimisation</b>	<b>Defined as BAT in BREF or TGN for:</b>
<b>Bag / Fabric filters (BF)</b>	Reliable abatement of particulate matter to below 5mg/m <sup>3</sup>	Max temp 250°C	Multiple compartments  Bag burst detectors	Most plants
<b>Wet scrubbing</b>	May reduce acid gases simultaneously.	Not normally BAT.  Liquid effluent produced	Require reheat to prevent visible plume and dew point problems.	Where scrubbing required for other pollutants
<b>Ceramic filters</b>	High temperature applications  Smaller plant.	May “blind” more than fabric filters		Small plant.  High temperature gas cleaning required.
<b>Electrostatic precipitators</b>	Low pressure gradient. Use with BF may reduce the energy consumption of the induced draft fan.	Not normally BAT.		When used with other particulate abatement plant

The Applicant proposes to use ceramic filters for the abatement of particulate matter from the Boiler. Ceramic filters provide reliable abatement of particulate matter to below 5 mg/m<sup>3</sup> and are BAT for high temperature installations. The Applicant proposes to use multiple compartment filters with pressure drop detection to minimise the risk of increased particulate emissions in the event of ceramic candle blinding or rupture.

Maximum emissions of particulate matter have been assessed as insignificant at relevant receptors, and so the Environment Agency agrees that the Applicant’s proposed technique is BAT for the installation.

## 6.2.2 Oxides of Nitrogen

<b>Oxides of Nitrogen : Primary Measures</b>				
<b>Technique</b>	<b>Advantages</b>	<b>Disadvantages</b>	<b>Optimisation</b>	<b>Defined as BAT in BREF or TGN for:</b>
<b>Low NOx burners</b>	Reduces NOx at source		Start-up, supplementary firing.	Where auxiliary burners required.
<b>Starved air systems</b>	Reduce CO simultaneously.			Pyrolysis, Gasification systems.
<b>Optimise primary and secondary air injection</b>				All plant.
<b>Flue Gas Recirculation (FGR)</b>	Reduces the consumption of reagents used for secondary NOx control.  May increase overall energy recovery	Some applications experience corrosion problems.		All plant unless impractical in design (needs to be demonstrated)

<b>Oxides of Nitrogen : Secondary Measures (BAT is to apply Primary Measures first)</b>				
<b>Technique</b>	<b>Advantages</b>	<b>Disadvantages</b>	<b>Optimisation</b>	<b>Defined as BAT in BREF or TGN for:</b>
<b>Selective catalytic reduction (SCR)</b>	NOx emissions < 70mg/ m <sup>3</sup>  Reduces CO, VOC, dioxins	Expensive.  Re-heat required – reduces plant efficiency		All plant
<b>Selective non-catalytic reduction (SNCR)</b>	NOx emissions typically 150 - 180mg/m <sup>3</sup>	Relies on an optimum temperature around 900 °C, and sufficient retention time for reduction  May lead to Ammonia slip	Port injection location	All plant unless lower NOx release required for local environmental protection.
<b>Reagent Type: Ammonia</b>	Likely to be BAT  Lower nitrous oxide formation	More difficult to handle  Narrower temperature window		All plant

Reagent Type: Urea	Likely to be BAT			All plant
--------------------	------------------	--	--	-----------

The Applicant proposes to implement the following primary measures:

- Low NO<sub>x</sub> burners – this technique reduces NO<sub>x</sub> at source and is defined as BAT where auxiliary burners are required.
- Optimise primary and secondary air injection – this technique is BAT for all plant.
- Flue gas recirculation – this technique reduces the consumption of reagents for secondary NO<sub>x</sub> control and can increase overall energy recovery, although in some applications there can be corrosion problems – the technique is considered BAT for all plant.

There are two recognised techniques for secondary measures to reduce NO<sub>x</sub>. These are Selective Catalytic Reduction (SCR) and Selective Non-Catalytic Reduction (SNCR). For each technique, there is a choice of urea or ammonia reagent.

SCR can reduce NO<sub>x</sub> levels to below 70 mg/m<sup>3</sup> and can be applied to all plant, it is generally more expensive than SNCR and requires reheating of the waste gas stream which reduces energy efficiency, periodic replacement of the catalysts also produces a hazardous waste. SNCR can typically reduce NO<sub>x</sub> levels to between 150 and 180 mg/m<sup>3</sup>, it relies on an optimum temperature of around 900 deg C and sufficient retention time for reduction. SNCR is more likely to have higher levels of ammonia slip. The technique can be applied to all plant unless lower NO<sub>x</sub> releases are required for local environmental protection. Urea or ammonia can be used as the reagent with either technique, urea is somewhat easier to handle than ammonia and has a wider operating temperature window, but tends to result in higher emissions of N<sub>2</sub>O. Either reagent is BAT, and the use of one over the other is not normally significant in environmental terms.

The Applicant proposes to use SNCR with urea as the reagent.

Emissions of NO<sub>x</sub> have been assessed as not insignificant but not significant, the maximum PC at modelled human receptors is <70% PEC, and so the Environment Agency agrees that the Applicant's proposed technique is BAT for the installation.

The amount of urea used for NO<sub>x</sub> abatement will need to be optimised to maximise NO<sub>x</sub> reduction and minimise NH<sub>3</sub> slip. Improvement condition IC5 requires the Operator to report to the Environment Agency on optimising the performance of the NO<sub>x</sub> abatement system. The Operator is also required to monitor and report on NH<sub>3</sub> and N<sub>2</sub>O emissions every 6 months.

### 6.2.3 Acid Gases, SO<sub>x</sub>, HCl and HF

<b>Acid gases and halogens : Primary Measures</b>				
<b>Technique</b>	<b>Advantages</b>	<b>Disadvantages</b>	<b>Optimisation</b>	<b>Defined as BAT in BREF or TGN for:</b>
<b>Low sulphur fuel, (&lt; 0.1%S gasoil or natural gas)</b>	Reduces SO <sub>x</sub> at source		Start-up, supplementary firing.	Where auxiliary fuel required.
<b>Management of waste streams</b>	Disperses sources of acid gases (e.g. PVC) through feed.	Requires closer control of waste management		All plant with heterogeneous waste feed

<b>Acid gases and halogens : Secondary Measures (BAT is to apply Primary Measures first)</b>				
<b>Technique</b>	<b>Advantages</b>	<b>Disadvantages</b>	<b>Optimisation</b>	<b>Defined as BAT in BREF or TGN for:</b>
<b>Wet</b>	High reaction rates  Low solid residues production  Reagent delivery may be optimised by concentration and flow rate	Large effluent disposal and water consumption if not fully treated for re-cycle  Effluent treatment plant required  May result in wet plume  Energy required for effluent treatment and plume reheat		Plants with high acid gas and metal components in exhaust gas – HWIs
<b>Dry</b>	Low water use  Reagent consumption may be reduced by recycling in	Higher solid residue production  Reagent consumption controlled only by input rate		All plant

	<p>plant</p> <p>Lower energy use</p> <p>Higher reliability</p>			
<b>Semi-dry</b>	<p>Medium reaction rates</p> <p>Reagent delivery may be varied by concentration and input rate</p>	<p>Higher solid waste residues</p>		All plant
<b>Reagent Type: Sodium Hydroxide</b>	<p>Highest removal rates</p> <p>Low solid waste production</p>	<p>Corrosive material</p> <p>ETP sludge for disposal</p>		HWIs
<b>Reagent Type: Lime</b>	<p>Very good removal rates</p> <p>Low leaching solid residue</p> <p>Temperature of reaction well suited to use with bag filters</p>	<p>Corrosive material</p> <p>May give greater residue volume if no in-plant recycle</p>	Wide range of uses	MWIs, CWIs
<b>Reagent Type: Sodium Bicarbonate</b>	<p>Good removal rates</p> <p>Easiest to handle</p> <p>Dry recycle systems proven</p>	<p>Efficient temperature range may be at upper end for use with bag filters</p> <p>– Leachable solid residues</p> <p>Bicarbonate more expensive</p>	Not proven at large plant	CWIs

The Applicant proposes to implement the following primary measures:

- Use of low sulphur fuels for start up and auxiliary burners – gas should be used if available, where fuel oil is used, this will be low sulphur (i.e. <0.1%), this will reduce SO<sub>x</sub> at source. The Applicant has justified its choice of natural gas as the support fuel on the basis that this ensures compliancy with EU Directive 75/716/EEC (as emended) and IED and we agree with that assessment.
- Management of heterogeneous wastes – this will disperse problem wastes such as PVC by ensuring a homogeneous waste feed.

There are three recognised techniques for secondary measures to reduce acid gases. These are wet, dry and semi-dry. Wet scrubbing produces an effluent for treatment and disposal in compliance with Article 46(3) of IED. It will also require reheat of the exhaust to avoid a visible plume. Wet scrubbing is unlikely to be BAT except where there are high acid gas and metal components in the exhaust gas as may be the case for some hazardous waste incinerators. In this case, the Applicant does not propose using wet scrubbing, and the Environment Agency agrees that wet scrubbing is not appropriate in this case.

The Applicant has therefore considered dry methods as secondary measures for acid gas abatement

Both dry and semi-dry methods rely on the dosing of powdered materials into the exhaust gas stream. Semi-dry systems (i.e. hydrated reagent) offer reduced material consumption through faster reaction rates, but reagent recycling in dry systems can offset this.

In both dry and semi-dry systems, the injected powdered reagent reacts with the acid gases and is removed from the gas stream by the ceramic filter system. The powdered materials are either lime or sodium bicarbonate. Both are effective at reducing acid gases, and dosing rates can be controlled from continuously monitoring acid gas emissions. The decision on which reagent to use is normally economic. Lime produces a lower leaching solid residue in the APC residues than sodium bicarbonate and the reaction temperature is well suited to bag filters, it tends to be lower cost, but it is a corrosive material and can generate a greater volume of solid waste residues than sodium bicarbonate. Either reagent is BAT, or the use of one over the other is not significant in environmental terms in this case.

In this case, the Applicant proposes that acid gases (HCl and HF produced from the gasification of the waste) will be removed from the syngas at the syngas ceramic filter. SO<sub>2</sub> produced from the gasification of the waste will be removed from the flue gas at the flue gas bag filter located prior to the exhaust stack. For both systems (flue gas and syngas filters), Lime will be injected using a dry system which will form a fully reactive coating on the ceramic filter candles / filter bags in order to neutralise the particular acid gases as described above. The reagent powders are discharged from both filters as

residue for removal and disposal off site. The Environment Agency is satisfied that this is BAT

#### 6.2.4 Carbon monoxide and volatile organic compounds (VOCs)

The prevention and minimisation of emissions of carbon monoxide and volatile organic compounds is through the optimisation of combustion controls, where all measures will increase the oxidation of these species.

<b>Carbon monoxide and volatile organic compounds (VOCs)</b>				
<b>Technique</b>	<b>Advantages</b>	<b>Disadvantages</b>	<b>Optimisation</b>	<b>Defined as BAT in BREF or TGN for:</b>
<b>Optimise combustion control</b>	All measures will increase oxidation of these species.		Covered in section on furnace selection	All plants

Syngas contains high concentrations of carbon monoxide and VOCs as a consequence of partial combustion in the gasifier. Effective combustion conditions exist within the boiler combustor section of the combined cycle waste heat recovery boiler (the final combustion stage) ensure that CO and VOC emissions are minimised and comply with the requirements of IED.

#### 6.2.5 Dioxins and furans (and Other POPs)

<b>Dioxins and furans</b>				
<b>Technique</b>	<b>Advantages</b>	<b>Disadvantages</b>	<b>Optimisation</b>	<b>Defined as BAT in BREF or TGN for:</b>
<b>Optimise combustion control</b>	All measures will increase oxidation of these species.		Covered in section on furnace selection	All plants
<b>Avoid <i>de novo</i> synthesis</b>			Covered in boiler design	All plant
<b>Effective Particulate matter removal</b>			Covered in section on particulate matter	All plant
<b>Activated Carbon injection</b>	Can be combined with acid gas absorber or fed separately.	Combined feed rate usually controlled by acid gas content.		All plant.  Separate feed normally BAT unless feed is constant and acid gas control also controls dioxin release.



The prevention and minimisation of emissions of dioxins and furans is achieved through:

- optimisation of combustion control including the maintenance of permit conditions on combustion temperature and residence time (.850°C for 2 sec), which has been considered in 6.1.1 above;
- avoidance of de novo synthesis, which has been covered in the consideration of boiler design;
- the effective removal of particulate matter, which has been considered in 6.2.1 above;
- injection of activated carbon. This can be combined with the acid gas reagent or dosed separately. Where the feed is combined, the combined feed rate will be controlled by the acid gas concentration in the exhaust. Therefore, separate feed of activated carbon would normally be considered BAT unless the feed was relatively constant. Effective control of acid gas emissions also assists in the control of dioxin releases.

In this case the Applicant proposes all of the above techniques and we are satisfied their proposals are BAT.

#### 6.2.6 Metals

<b>Metals</b>				
<b>Technique</b>	<b>Advantages</b>	<b>Disadvantages</b>	<b>Optimisation</b>	<b>Defined as BAT in BREF or TGN for:</b>
<b>Effective Particulate matter removal</b>			Covered in section on particulate matter	All plant
<b>Activated Carbon injection for mercury recovery</b>	Can be combined with acid gas absorber or fed separately.	Combined feed rate usually controlled by acid gas content.		All plant.  Separate feed normally BAT unless feed is constant and acid gas control also controls dioxin release.

The prevention and minimisation of metal emissions is achieved through the effective removal of particulate matter, and this has been considered in 6.2.1 above.

Unlike other metals however, mercury if present will be in the vapour phase. BAT for mercury removal is also dosing of activated carbon into the exhaust gas stream. This can be combined with the acid gas reagent or dosed separately. Where the feed is combined, the combined feed rate will be controlled by the acid gas concentration in the exhaust. Therefore, separate

feed of activated carbon would normally be considered BAT unless the feed was relatively constant.

In this case the Applicant proposes activated carbon feed and we are satisfied their proposals are BAT.

### 6.3 BAT and global warming potential

This section summarises the assessment of greenhouse gas impacts which has been made in the determination of this Permit. Emissions of carbon dioxide (CO<sub>2</sub>) and other greenhouse gases differ from those of other pollutants in that, except at gross levels, they have no localised environmental impact. Their impact is at a global level and in terms of climate change. Nonetheless, CO<sub>2</sub> is clearly a pollutant for IED purposes.

The principal greenhouse gas emitted is CO<sub>2</sub>, but the plant also emits small amounts of N<sub>2</sub>O arising from the operation of secondary NO<sub>x</sub> abatement. N<sub>2</sub>O has a global warming potential 310 times that of CO<sub>2</sub>. The Applicant will therefore be required to optimise the performance of the secondary NO<sub>x</sub> abatement system to ensure its GWP impact is minimised.

The major source of greenhouse gas emissions from the installation is however CO<sub>2</sub> from the combustion of the syngas arising from the gasification of waste. There will also be CO<sub>2</sub> emissions from the burning of support fuels at start up, shut down and should it be necessary to maintain combustion temperatures. BAT for greenhouse gas emissions is to maximise energy recovery and efficiency.

The electricity that is generated by the Installation will displace emissions of CO<sub>2</sub> elsewhere in the UK, as virgin fossil fuels will not be burnt to create the same electricity. The Applicant has therefore included within its GWP calculations a CO<sub>2</sub> offset for the net amount of electricity exported from the Installation. The Applicant used the Environment Agency's H1 methodology to assess the plants global warming potential using a specific calculation, which resulted in a GWP of 42,393.75.

The Installation is not subject to the Greenhouse Gas Emissions Trading Scheme Regulations 2003; therefore it is a requirement of IED to investigate how emissions of greenhouse gases emitted from the installation might be prevented or minimised.

The Applicant has considered GWP as part of its BAT options appraisal. There are a number of areas in which a difference can be made to the GWP of the Installation in summary: the following factors influence the GWP of the facility:-

On the debit side

- CO<sub>2</sub> emissions from the burning of syngas arising from the gasification of waste;

- CO<sub>2</sub> emissions from burning auxiliary or supplementary fuels;
- CO<sub>2</sub> emissions associated with electrical energy used;
- N<sub>2</sub>O from the de-NO<sub>x</sub> process.
- The assessment of options for the control of acid gases and halogens.

On the credit side

- CO<sub>2</sub> saved from the export of electricity to the public supply by displacement of burning of virgin fuels;
- CO<sub>2</sub> saved from the use of waste heat by displacement of burning of virgin fuels
- Avoidance of methane which would be formed if the waste was landfilled

The Applicant's assessment shows that the GWP of the plant is dominated by the emissions of carbon dioxide that are released as a result of waste combustion. This is constant for all options considered in the BAT assessment.

The differences in the GWP of the options in the BAT appraisal arise from small differences in energy recovery and in the amount of N<sub>2</sub>O emitted.

Taking all these factors into account, the Operator's assessment shows their preferred option is best in terms of GWP.

The Environment Agency agrees with this assessment and that the chosen option is BAT for the installation.

#### 6.4 BAT and POPs

International action on Persistent Organic pollutants (POPs) is required under the UN's Stockholm Convention, which entered into force in 2004. The EU implemented the Convention through the POPs Regulation (850/2004), which is directly applicable in UK law. The Environment Agency is required by national POPs Regulations (SI 2007 No 3106) to give effect to Article 6(3) of the EC POPs Regulation when determining applications for environmental Permits.

However, it needs to be borne in mind that this application is for a particular type of installation, namely a waste incinerator. The Stockholm Convention distinguishes between intentionally-produced and unintentionally-produced POPs. Intentionally-produced POPs are those used deliberately (mainly in the past) in agriculture (primarily as pesticides) and industry. Those intentionally-produced POPs are not relevant where waste incineration is concerned, as in fact high-temperature incineration is one of the prescribed methods for destroying POPs.

The unintentionally-produced POPs addressed by the Convention are:

- dioxins and furans;

- HCB (hexachlorobenzene)
- PCBs (polychlorobiphenyls) and
- PeCB (pentachlorobenzene)

The UK's national implementation plan for the Stockholm Convention, published in 2007, makes explicit that the relevant controls for unintentionally-produced POPs, such as might be produced by waste incineration, are delivered through the requirements of IED. That would include an examination of BAT, including potential alternative techniques, with a view to preventing or minimising harmful emissions. These have been applied as explained in this document, which explicitly addresses alternative techniques and BAT for the minimisation of emissions of dioxins.

Our legal obligation, under regulation 4(b) of the POPs Regulations, is, when considering an application for an environmental permit, to comply with article 6(3) of the POPs Regulation:

“Member States shall, when considering proposals to construct new facilities or significantly to modify existing facilities using processes that release chemicals listed in Annex III, without prejudice to Council Directive 1996/61/EC, give priority consideration to alternative processes, techniques or practices that have similar usefulness but which avoid the formation and release of substances listed in Annex III.”

The 1998 Protocol to the Convention recommended that unintentionally produced should be controlled by imposing emission limits (e.g 0.1 ng/m<sup>3</sup> for MWIs) and using BAT for incineration. UN Economic Commission for Europe (Executive Body for the Convention) (ECE-EB) produced BAT guidance for the parties to the Convention in 2009. This document considers various control techniques and concludes that primary measures involving management of feed material by reducing halogenated substances are not technically effective. This is not surprising because halogenated wastes still need to be disposed of and because POPs can be generated from relatively low concentrations of halogens. In summary, the successful control techniques for waste incinerators listed in the ECE-EB BAT are:

- maintaining furnace temperature of 850°C and a combustion gas residence time of at least 2 seconds
- rapid cooling of flue gases to avoid the *de novo* reformation temperature range of 250-450°C
- use of bag filters and the injection of activated carbon or coke to adsorb residual POPs components.

Using the methods listed above, the UN-ECE BAT document concludes that incinerators can achieve an emission concentration of 0.1 ng TEQ/m<sup>3</sup>.

We believe that the Permit ensures that the formation and release of POPs will be prevented or minimised. As we explain above, high-temperature incineration is one of the prescribed methods for destroying POPs. Permit conditions are based on the use of BAT and Chapter IV of IED and

incorporate all the above requirements of the UN-ECE BAT guidance and deliver the requirements of the Stockholm Convention in relation to unintentionally produced POPs.

The release of **dioxins and furans** to air is required by the IED to be assessed against the I-TEQ (International Toxic Equivalen) limit of 0.1 ng/m<sup>3</sup>. Further development of the understanding of the harm caused by dioxins has resulted in the World Health Organisation (WHO) producing updated factors to calculate the WHO-TEQ value. Certain **PCBs** have structures which make them behave like dioxins (dioxin-like PCBs), and these also have toxic equivalence factors defined by WHO to make them capable of being considered together with dioxins. The UK's independent health advisory committee, the Committee on Toxicity of Chemicals in Food, Consumer Products and the Environment (COT) has adopted WHO-TEQ values for both dioxins and dioxin-like PCBs in their review of Tolerable Daily Intake (TDI) criteria. EPR requires that, in addition to the requirements of the IED, the WHO-TEQ values for both dioxins and dioxin-like PCBs should be specified for monitoring and reporting purposes, to enable evaluation of exposure to dioxins and dioxin-like PCBs to be made using the revised TDI recommended by COT. The release of dioxin-like PCBs and PAHs is expected to be low where measures have been taken to control dioxin releases. EPR requires monitoring of a range of PAHs and dioxin-like PCBs in waste incineration Permits at the same frequency as dioxins are monitored. We have included a requirement to monitor and report against these WHO-TEQ values for dioxins and dioxin-like PCBs and the range of PAHs identified by Defra in the Environmental Permitting Guidance on the IED. We are confident that the measures taken to control the release of dioxins will also control the releases of dioxin-like PCBs and PAHs. Section 5.2.1 and Section 5.5 of this document details the assessment of emissions to air, which includes dioxins and concludes that there will be no adverse effect on human health from either normal or abnormal operation.

**Hexachlorobenzene (HCB)** is released into the atmosphere as an accidental product from the combustion of coal, waste incineration and certain metal processes. It has also been used as a fungicide, especially for seed treatment although this use has been banned in the UK since 1975. Natural fires and volcanoes may serve as natural sources. Releases of (HCB) are addressed by the European Environment Agency (EEA), which advises that:

*"due to comparatively low levels in emissions from most (combustion) processes special measures for HCB control are usually not proposed. HCB emissions can be controlled generally like other chlorinated organic compounds in emissions, for instance dioxins/furans and PCBs: regulation of time of combustion, combustion temperature, temperature in cleaning devices, sorbents application for waste gases cleaning etc."* [reference [http://www.eea.europa.eu/publications/EMEPCORINAIR4/sources\\_of\\_HCB.pdf](http://www.eea.europa.eu/publications/EMEPCORINAIR4/sources_of_HCB.pdf)]

Pentachlorobenzene (PeCB) is another of the POPs list to be considered under incineration. PeCB has been used as a fungicide or flame retardant, there is no data available however on production, recent or past, outside the UN-ECE region. PeCBs can be emitted from the same sources as for PCDD/F: waste incineration, thermal metallurgic processes and combustion plants providing energy. As discussed above, the control techniques described in the UN-ECE BAT guidance and included in the permit, are effective in controlling the emissions of all relevant POPs including PeCB.

We have assessed the control techniques proposed for dioxins by the Applicant and have concluded that they are appropriate for dioxin control. We are confident that these controls are in line with the UN-ECE BAT guidance and will minimise the release of HCB, PCB and PeCB.

We are therefore satisfied that the substantive requirements of the Convention and the POPs Regulation have been addressed and complied with.

## 6.5 Other Emissions to the Environment

### 6.5.1 Emissions to water

The site will be fully sealed/bunded and will only have a single discharge point to sewer.

Based upon the information in the application we are satisfied that appropriate measures will be in place to prevent and /or minimise emissions to water.

### 6.5.2 Emissions to sewer

The site will be fully sealed/bunded and will only have a single discharge point to sewer, appropriate silt traps and interceptors will be fitted where required. Only clean surface waters will be discharged in accordance with the appropriate discharge consent.

Only boiler blowdown and power module condensate will be discharged to foul drain. In accordance with the flowchart given H1 Annex D, as there are no dangerous substances discharged to sewer.

Based upon the information in the application we are satisfied that appropriate measures will be in place to prevent and /or minimise emissions to sewer.

### 6.5.3 Fugitive emissions

The IED specifies that plants must be able to demonstrate that the plant is designed in such a way as to prevent the unauthorised and accidental release of polluting substances into soil, surface water and groundwater. In addition storage requirements for waste and for contaminated water of Article 46(5) must be arranged.

Fugitive releases have been identified by the Applicant and assessed as part of the Environmental Risk Assessment. Following processing, waste from the gasifier is emptied into a hopper. This hopper has an extraction hood, which is ducted to a bag filter prior to an exhaust stack. This system provides constant extraction to prevent the escape of fugitive dust emissions. The hopper has a vibratory feeder at the base. This links to a vibratory feeder which then passes through a cooling drum. Air is pulled through the outlet of the cooling drum and through the post-processed material, which cools the material; again this cooling air is extracted through the bag filter. The assessment indicates that the proposed measures for control of fugitive releases will ensure that no significant risks from fugitive releases are expected from the proposed EfW facility.

Good housekeeping practices will be in operation to ensure that any spillages or potentially dusty emissions are prevented or cleared up at the earliest opportunity. Spill kits will be available for clean up of all chemicals and oils stored and used within the EfW facility and will be located in proximity to the relevant storage areas and delivery points. Site procedures will detail those actions that should be followed in the event of a spillage.

In relation to water emissions to surface, groundwater and/or sewers, the site will be fully sealed and will only have a single discharge point to public sewer with no diffused discharges to any receptor. Whilst there is a risk of emission, the pathway to sensitive receptors is non-existent and there is negligible risk to any receptor. Potential fugitive releases to sewer are likely to occur only as a result of an incident or accident.

Based upon the information in the application we are satisfied that appropriate measures will be in place to prevent and /or minimise fugitive emissions.

#### 6.5.4 Odour

Based upon the information in the application we are satisfied that the appropriate measures will be in place to prevent or where that is not practicable to minimise odour and to prevent pollution from odour.

Waste accepted at the installation will be delivered in covered vehicles or within containers and bulk storage of waste will only occur in the installation's waste bunker. A roller shutter door will be used to close the entrance to the tipping hall outside of the waste delivery periods. All spillages will be cleared up as soon as practicable in line with good housekeeping practice; potentially odorous wastes will be cleaned up immediately. Waste will be stored for a maximum of three days.

Odorous emissions from the main stack will be prevented by efficient combustion in the secondary combustion chambers to minimise the potential for the creation of odorous substances.

The EMS required by condition 1.1.1 of the Permit and the pre-operational condition P03 shall provide details for the management of odours from on-site activities, wastes, process residues and water storage facilities. However, were an odour issue to arise, condition 3.3.2 could require a separate odour management plan to be agreed and implemented in addition to those measures.

#### 6.5.5 Noise and vibration

Based upon the information in the application we are satisfied that the appropriate measures will be in place to prevent or where that is not practicable to minimise noise and vibration and to prevent pollution from noise and vibration outside the site.

The Applicant has used the older version BS4142:1997 for their noise impact assessment. At the time their report was written, this version of the standard was appropriate. There is now an updated version of BS4142 (2014) which we have used to consider the Applicant's consultant's predictions.

The consultant predicts noise impacts at residential receptors to be below background level and will have less than marginal significance in accordance with BS4142:1997.

We have audited the consultant's model and have identified several aspects that may underestimate the noise impacts at receptors:

- Unsubstantiated reverberant sound levels
- Discrepancies between number of HGV movements modelled and in the report
- Height of the stack emission point modelled at 0.5m instead of 50m
- No background noise survey at weekend when background may be lower

Our sensitivity checks to the above factors indicate impacts at receptors could be higher than modelled by the consultant. As such we do not agree with the consultant's numerical predictions but we do agree with their conclusions that BS4142 rating levels are likely to be less than marginal significance (or less than likelihood of adverse impact in 2014 version terminology) dependent on no tonal, impulse or intermittent penalty being applicable.

A BS4142 assessment was considered not relevant for a Traveller's Park located 100m away from the facility due to infrequent occupancy. However check modelling indicates it is subject to the highest noise impact due to its proximity. Depending on the background levels and occupancy status of the receptor, this location could be subject to adverse impacts from the facility.

The consultant used modelling software Soundplan v7.3 to predict the noise impact from the proposed facility. Soundplan implements the attenuation calculation scheme detailed in ISO 96136. The consultant modelled 2 scenarios:

- Plan 1 – Daytime noise with all sources which includes HGVs, Cars, RODECs, manufacture and R&D



Plan 2 – Evening and night time noise which includes RODECs sources only.

The consultant modelled several noise sources as a combination of point source, line source and sound emitting buildings.

Twenty six outdoor point sources were included within the consultant’s model, which included a stack with a sound power level of 90dB(A). Note that this sound power level already assumes a sound reduction of -25dB(A) which the consultant states is achieved by a use of a silencer. Additionally, the consultant modelled the stack point source at a height of 0.5m instead of 50m as stated in the report. We have carried out sensitivity to this.

The consultant states that vehicle movements (HGVs) will be limited to between 08:00-18:00 and have been considered within the model as a series of line sources for the daytime scenario. The consultant states they derived a sound pressure level (SPL) of 80dB(A) at 7.5m for HGVs and 74dB(A) at 7.5m for cars using the BS5228 Haul Road Calculation. Although they have not provided the average speed of the moving vehicles, the values inputted to Soundplan are appropriate based on the number of vehicles stated within the model. However the number of vehicle movement per hour is higher in the report than modelled; we have carried out sensitivity to this.

The consultant did not provide any calculations or justification for the exterior facade emission values ( $L_w$ ) used in Soundplan for the industrial buildings. We were able to calculate the reverberant sound pressures ( $L_{prev}$ ) based on these  $L_w$  values and the building material sound reduction indices values provided in the report. Note that all sources were modelled at 500Hz only. However noise emissions from sources may be dominated by sound emitted at frequencies different to 500Hz. Noise attenuation reacts differently at different frequencies, particularly for sources that are dominated by a lower frequency. We would therefore have expected sound spectra information to be presented for each source to account for this.

Within their report the consultant considered impacts at 3 residential receptor locations: Norwich Gardens, Langdown Close and the MUSE development. However, in the Soundplan model an additional 12 receptors were identified. We would have expected all relevant receptors in close proximity of the site to have been included within the BS4142 assessment in the report. In particular, a traveller’s park, identified as a receptor in the model file, is located 100m from the nearest noise source on site. Modelling predictions show that this site is subject to the highest impact of all the receptors. However, this site was not included within the consultant’s BS4142 assessment. However, the consultant does state in their report that the travellers park (also known as the showman’s wintering ground) is used “primarily for the storage and maintenance of equipment/trailer mounted fairground equipment and mobile homes... people seem to rarely reside at the location only seemingly staying on site when maintenance tasks over-run/require or prior to early starts for haulage” as such they have not considered this location a true noise sensitive receptor.

The consultant did not use their own background monitoring data within the assessment. They considered data taken by Sharps Redmore (SR) in September 2012 appropriate for the purpose of the application at the time their report was written in 2013. Similarly baseline monitoring undertaken by URS for the MUSE development carried out in June 2012 was also considered appropriate.

Background monitoring undertaken by SR was carried out on Tuesday 4th and Wednesday 5th September 2012 at Norwich Gardens and Langdown Close. As the site will operate for 7 days a week, we would have also expected weekend monitoring to have been undertaken at these two locations. Weekend noise levels could potentially be lower than during the weekdays due to different local activity levels.

The consultant has assessed the noise impact at residential locations using the old BS4142:1997 methodology. An updated version BS4142:2014 released in October 2014 assesses the excess of the rating levels over the measured background sound levels where:

- A difference of around +10dB or more is likely to be an indication of significant adverse impact, depending on the context.
- A difference of +10dB or more indicates complaints are likely.
- A difference of +5dB is of marginal significance.
- If the rating level is more than 10dB below the measured background level then this is a positive indication complaints are unlikely.
- A difference of around +5dB is likely to be an indication of an adverse impact, depending on the context.
- Where the rating level does not exceed the background sound level, this is an indication of the specific sound source having a low impact, depending on the context.

BS:4142:1997 states a 5dB correction factor should be added to the predicted noise level, where certain noise features (i.e. bangs, clatters, thumps etc ) are present. The consultant did not apply this correction factor as they considered the noise associated with the proposed Chinook facility would not be distinct / "out of character" of its location within the industrial estate. Note that BS4142:2014 applies different penalties against tonality, impulsivity and intermittent sounds.

The consultant predicts for weekday daytime and evening impacts will be "less than marginal significance". Weekday overnight impacts are also less than marginal significance with a rating level of +3dB(A) at Norwich Gardens. A weekend assessment was not included. In terms of the new BS4142:2014, the consultant's predicted specific sound sources will be less than likelihood of adverse impact at receptors.

We carried out check calculations and modelling using Soundplan v7.3 based on the consultant's sound power levels, sound reduction values, other parameters contained in the assessment and the consultant's modelling files.

Our sensitivity analysis and check modelling tested sensitivity of model output and results to the following parameters:

- Stack heightpoint source at 50m
- Height of HGVs at 1.5m
- Sound power of line source at 72dB to represent 8 HGV movements per hour
- Ground absorption of 0 i.e as totally reflecting
- 2m resolution terrain data obtained from Environment Agency's Geomatics Group.

We carried out check calculations for the external facade levels from the industrial buildings based on the SRI values provided by the consultant, sound power of internal sources provided in the additional information and a worst case assumed absorption co-efficient of 0.15 (Kingspan KS1000 + no lining). We were not able to replicate the values the consultant used within their Soundplan model.

We back calculated reverberant sound pressures ( $L_{prev}$ ) based on the consultant's model values for facade emissions ( $L''_w$ ) and the sound reduction values provided in the consultant's report. Note that a Ctr correction was not applied. Our calculations showed the following reverberant levels:

Name of building	$L_{prev}$ (dB(A)) = $L''_w$ +SRI +6
Manufacture Building	91
RD Building	86
RODECs Waste reception	84
RODECs Hall	87
RODECs building	91
RODECs Engine Hall	91

There are many uncertainties present within the consultant's modelling files and assessment. Although we do not agree with the consultant's absolute numerical predictions, we agree with their conclusion that specific sound levels generated from the facility are less than likely to have an adverse impact at receptors. Note, this is dependent on a maximum  $L_{prev}$  as presented in the table above for the industrial buildings (impacts at receptors will be higher if these are exceeded) and mitigation measures being applied as stated in the report.

Although the consultant states that the facility would not be distinct or "out of character" of its location within the industrial estate, this applies to the receptors of Norwich Gardens and Langdown Close. Due to the proximity of the Traveller's Park to the site, it may be subject to tonal, impulsive or intermittent noise features from the site, in particular tonal features from the cooling fans. This has not been considered by the consultant and may be required in further assessment depending on the status of the Traveller's site as mentioned above.

Condition 1.1 of the Permit and pre-operational condition PO3 require that the EMS is in place prior to operation of the proposed plant, and we would normally expect the EMS to cover noise management. Condition 3.4 requires noise to be managed in such a way as to not cause pollution outside the site and, where this has not been achieved, the implementation of a separate noise management plan. We believe that the controls proposed are BAT and, along with the conditions in place in the permit, that the proposed activity is unlikely to give rise to noise complaints.

## 6.6 Setting ELVs and other Permit conditions

### 6.6.1 Translating BAT into Permit conditions

Article 14(3) of IED states that BAT conclusions shall be the reference for permit conditions. Article 15(3) further requires that under normal operating conditions; emissions do not exceed the emission levels associated with the best available techniques as laid down in the decisions on BAT conclusions.

The use of IED Chapter IV emission limits for air dispersion modelling sets the worst case scenario. If this shows emissions are insignificant then we have accepted that the Applicant's proposals are BAT, and that there is no justification to reduce ELVs below the Chapter IV limits in these circumstances. For their emission impact assessments the Applicant used emission rates derived from the IED Chapter IV, Annex VI, Part 3 with the exception on NO<sub>x</sub> and SO<sub>2</sub>, where the Applicant used lower maximum emission levels of 90mg/Nm<sup>3</sup> and 40mg/Nm<sup>3</sup> respectively. These lower ELVs for NO<sub>x</sub> and SO<sub>2</sub> will be set in the Permit as the permitted ELVs.

Below we consider whether, for those emission not screened out as insignificant, different conditions are required as a result of consideration of local or other factors, so that no significant pollution is caused (Article 11(c)) or to comply with environmental quality standards (Article 18).

#### (i) Local factors

We have considered the following information:- location and proximity to nearby residents and wildlife habitats, the air quality and habitats assessments, human health risk assessment, proposed design and air pollution control systems and we are satisfied that for the incineration plant there is no justification to reduce ELVs below those established by IED.

#### (ii) National and European EQSs

We are satisfied that the limits imposed under the Industrial Emissions Directive are appropriate for the installation with no further changes.

#### (iii) Global Warming

CO<sub>2</sub> is an inevitable product of the combustion of waste. The amount of CO<sub>2</sub> emitted will be essentially determined by the quantity and characteristics of waste being incinerated, which are already subject to conditions in the Permit. It is therefore inappropriate to set an emission limit value for CO<sub>2</sub>, which could do no more than recognise what is going to be emitted. The gas is not therefore targeted as a key pollutant under Annex II of IED, which lists the main polluting substances that are to be considered when setting emission limit values (ELVs) in Permits.

We have therefore considered setting equivalent parameters or technical measures for CO<sub>2</sub>. However, provided energy is recovered efficiently (see section 4.3.7 above), there are no additional equivalent technical measures (beyond those relating to the quantity and characteristics of the waste) that can be imposed that do not run counter to the primary purpose of the plant, which is the recovery of energy from waste. Controls in the form of restrictions on the volume and type of waste that can be accepted at the Installation and permit conditions relating to energy efficiency effectively apply equivalent technical measures to limit CO<sub>2</sub> emissions.

#### (iv) Commissioning

We have included a pre-operational condition (PO6) which requires the Applicant to submit a written commissioning plan, including timescales for completion. This condition also requires the Applicant to summarise the expected emissions to the environment during the different phases of commissioning and the actions to be taken to protect the environment.

### 6.7 Monitoring

#### 6.7.1 Monitoring during normal operations

We have decided that monitoring should be carried out for the parameters listed in Schedule 3 of the Permit using the methods and to the frequencies specified in those tables. These monitoring requirements have been imposed in order to demonstrate compliance with emission limit values and to enable correction of measured concentration of substances to the appropriate reference conditions; to gather information about the performance of the SNCR system; to deliver the EPR requirement that dioxin-like PCBs and PAHs should be monitored and to deliver the requirements of Chapter IV of IED for monitoring of residues and temperature in the combustion chamber.

For emissions to air, the methods for continuous and periodic monitoring are in accordance with the Environment Agency's Guidance M2 for monitoring of stack emissions to air.

Based on the information in the Application and the requirements set in the conditions of the permit we are satisfied that the Operator's techniques, personnel and equipment will have either MCERTS certification or MCERTS accreditation as appropriate.

### 6.7.2 Monitoring under abnormal operations arising from the failure of the installed CEMs

Article 50(4)(c) of IED requires that waste incineration and co-incineration plants shall operate an automatic system to prevent waste feed whenever any of the continuous emission monitors show that an emission limit value (ELV) is exceeded due to disturbances or failures of the purification devices. Notwithstanding this, Article 46(6) allows for the continued incineration and co-incineration of waste under such conditions provided that this period does not (in any circumstances) exceed 4 hours uninterrupted continuous operation or the cumulative period of operation does not exceed 60 hours in a calendar year. This is a recognition that the emissions during transient states (e.g. start-up and shut-down) are higher than during steady-state operation, and the overall environmental impact of continued operation with a limited exceedance of an ELV may be less than that of a partial shut-down and re-start.

Back up CEMS are not being used, if the period of abnormal operation cannot be resolved within the allocated 4hrs as per Article 46(6) the plant will go into full automatised shutdown.

### 6.7.3 Continuous emissions monitoring for dioxins and heavy metals

Chapter IV of IED specifies manual extractive sampling for heavy metals and dioxin monitoring. However, Article 48(5) of the IED enables The Commission to act through delegated, authority to set the date from which continuous measurements of the air emission limit values for heavy metals, dioxins and furans shall be carried out, as soon as appropriate measurement techniques are available within the Community. No such decision has yet been made by the Commission.

The Environment Agency has reviewed the applicability of continuous sampling and monitoring techniques to the installation.

Recent advances in mercury monitoring techniques have allowed standards to be developed for continuous mercury monitoring, including both vapour-phase and particulate mercury. There is a standard which can apply to CEMs which measure mercury (EN 15267-3) and standards to certify CEMs for mercury, which are EN 15267-1 and EN 15267-3. Furthermore, there is an MCERTS-certified CEM which has been used in trials in the UK and which has been verified on-site using many parallel reference tests as specified using the steps outlined in EN 14181.

In the case of dioxins, equipment is available for taking a sample for an extended period (several weeks), but the sample must then be analysed in the conventional way. However, the continuous sampling systems do not meet the requirements of BS EN 1948 which is the standard for dioxin analysis. BS

EN 1948 requires traversing the sampler across the duct and collecting parts of the sample at various points across the duct to ensure that all of the gas phase is sampled proportionately, in case there are variations in gas flow rate or composition resulting in a non-homogeneous gas flow. This requirement is particularly important where suspended solids are present in the gas, and dioxins are often associated with suspended solid particles. Continuous samplers are currently designed for operation at one or two fixed sampling points within the duct, and traverses are not carried out automatically. Using such samplers, more information could be obtained about the variation with time of the dioxin measurement, but the measured results could be systematically higher or lower than those obtained by the approved standard method which is the reference technique required to demonstrate compliance with the limit specified in the IED. The lack of a primary reference method (e.g. involving a reference gas of known concentration of dioxin) prohibits any one approach being considered more accurate than another. Because compliance with the IED's requirements is an essential element of EPR regulation, we have set emission limits for dioxins in the permit based on the use of BS EN 1948 and the manual sampling method remains the only acceptable way to monitor dioxins for the purpose of regulation.

For either continuous monitoring of mercury or continuous sampling of dioxins to be used for regulatory purposes, an emission limit value would need to be devised which is applicable to continuous monitoring. Such limits for mercury and dioxins have not been set by the European Commission. Use of a manual sample train is the only technique which fulfils the requirements of the IED. At the present time, it is considered that in view of the predicted low levels of mercury and dioxin emission it is not justifiable to require the Operator to install additionally continuous monitoring or sampling devices for these substances.

In accordance with its legal requirement to do so, the Environment Agency reviews the development of new methods and standards and their performance in industrial applications. In particular the Environment Agency considers continuous sampling systems for dioxins to have promise as a potential means of improving process control and obtaining more accurate mass emission estimates.

## 6.8 Reporting

We have specified the reporting requirements in Schedule 5 of the Permit either to meet the reporting requirements set out in the IED, or to ensure data is reported to enable timely review by the Environment Agency to ensure compliance with permit conditions and to monitor the efficiency of material use and energy recovery at the installation.

## 7 Other legal requirements

In this section we explain how we have addressed other relevant legal requirements, to the extent that we have not addressed them elsewhere in this document.

### 7.1 The EPR 2010 and related Directives

The EPR delivers the requirements of a number of European and national laws.

#### 7.1.1 Schedules 1 and 7 to the EPR 2010 – IED Directive

We address the requirements of the IED in the body of this document above and the specific requirements of Chapter IV in Annex 1 of this document.

There is one requirement not addressed above, which is that contained in Article 5(3) IED. Article 5(3) requires that “In the case of a new installation or a substantial change where Article 4 of Directive 85/337/EC (the EIA Directive) applies, any relevant information obtained or conclusion arrived at pursuant to articles 5, 6 and 7 of that Directive shall be examined and used for the purposes of granting the permit.”

- Article 5 of EIA Directive relates to the obligation on developers to supply the information set out in Annex IV of the Directive when making an application for development consent.
- Article 6(1) requires Member States to ensure that the authorities likely to be concerned by a development by reason of their specific environmental responsibilities are consulted on the Environmental Statement and the request for development consent.
- Article 6(2)-6(6) makes provision for public consultation on applications for development consent.
- Article 7 relates to projects with transboundary effects and consequential obligations to consult with affected Member States.

The grant or refusal of development consent is a matter for the relevant local planning authority. The Environment Agency’s obligation is therefore to examine and use any relevant information obtained or conclusion arrived at by the local planning authorities pursuant to those EIA Directive articles.

In determining the Application we have considered the following documents: -

- The Environmental Statement submitted with the planning application (which also formed part of the Environmental Permit Application).
- The decision of the Sheffield City Council to grant planning permission on 04<sup>th</sup> march 2013.
- The report and decision notice of the local planning authority accompanying the grant of planning permission.
- The response of the Environment Agency to the local planning authority in its role as consultee to the planning process.



From consideration of all the documents above, the Environment Agency considers that no additional or different conditions are necessary.

The Environment Agency has also carried out its own consultation on the Environmental Permitting Application which includes the Environmental Statement submitted to the local planning authority. The results of our consultation are described elsewhere in this decision document.

#### 7.1.2 Schedule 9 to the EPR 2010 – Waste Framework Directive

As the Installation involves the treatment of waste, it is carrying out a *waste operation* for the purposes of the EPR 2010, and the requirements of Schedule 9 therefore apply. This means that we must exercise our functions so as to ensure implementation of certain articles of the WFD.

We must exercise our relevant functions for the purposes of ensuring that the waste hierarchy referred to in Article 4 of the Waste Framework Directive is applied to the generation of waste and that any waste generated is treated in accordance with Article 4 of the Waste Framework Directive. (See also section 4.3.9)

The conditions of the permit ensure that waste generation from the facility is minimised. Where the production of waste cannot be prevented it will be recovered wherever possible or otherwise disposed of in a manner that minimises its impact on the environment. This is in accordance with Article 4.

We must also exercise our relevant functions for the purposes of implementing Article 13 of the Waste Framework Directive; ensuring that the requirements in the second paragraph of Article 23(1) of the Waste Framework Directive are met; and ensuring compliance with Articles 18(2)(b), 18(2)(c), 23(3), 23(4) and 35(1) of the Waste Framework Directive.

Article 13 relates to the protection of human health and the environment. These objectives are addressed elsewhere in this document.

Article 23(1) requires the permit to specify:

- (a) the types and quantities of waste that may be treated;
- (b) for each type of operation permitted, the technical and any other requirements relevant to the site concerned;
- (c) the safety and precautionary measures to be taken;
- (d) the method to be used for each type of operation;
- (e) such monitoring and control operations as may be necessary;
- (f) such closure and after-care provisions as may be necessary.

These are all covered by permit conditions.

The permit does not allow the mixing of hazardous waste so Article 18(2) is not relevant.

We consider that the intended method of waste treatment is acceptable from the point of view of environmental protection so Article 23(3) does not apply. Energy efficiency is dealt with elsewhere in this document but we consider the conditions of the permit ensure that the recovery of energy take place with a high level of energy efficiency in accordance with Article 23(4).

Article 35(1) relates to record keeping and its requirements are delivered through permit conditions.

### 7.1.3 Schedule 22 to the EPR 2010 – Groundwater, Water Framework and Groundwater Daughter Directives

To the extent that it might lead to a discharge of pollutants to groundwater (a “groundwater activity” under the EPR 2010), the Permit is subject to the requirements of Schedule 22, which delivers the requirements of EU Directives relating to pollution of groundwater. The Permit will require the taking of all necessary measures to prevent the input of any hazardous substances to groundwater, and to limit the input of non-hazardous pollutants into groundwater so as to ensure such pollutants do not cause pollution, and satisfies the requirements of Schedule 22.

No releases to groundwater from the Installation are permitted. The Permit also requires material storage areas to be designed and maintained to a high standard to prevent accidental releases.

### 7.1.4 Directive 2003/35/EC – The Public Participation Directive

Regulation 59 of the EPR 2010 requires the Environment Agency to prepare and publish a statement of its policies for complying with its public participation duties. We have published our public participation statement.

This Application has been consulted upon in line with this statement, as well as with our guidance RGS6 on Sites of High Public Interest, which addresses specifically extended consultation arrangements for determinations where public interest is particularly high. This satisfies the requirements of the Public Participation Directive.

## 7.2 National primary legislation

### 7.2.1 **Environment Act 1995**

#### (i) Section 4 (Pursuit of Sustainable Development)

We are required to contribute towards achieving sustainable development, as considered appropriate by Ministers and set out in guidance issued to us. The Secretary of State for Environment, Food and Rural Affairs has issued *The Environment Agency’s Objectives and Contribution to Sustainable Development: Statutory Guidance (December 2002)*. This document:

*“provides guidance to the Agency on such matters as the formulation of approaches that the Agency should take to its work, decisions about priorities for the Agency and the allocation of resources. It is not directly applicable to individual regulatory decisions of the Agency”.*

In respect of regulation of industrial pollution through the EPR, the Guidance refers in particular to the objective of setting permit conditions *“in a consistent and proportionate fashion based on Best Available Techniques and taking into account all relevant matters...”*. The Environment Agency considers that it has pursued the objectives set out in the Government’s guidance, where relevant, and that there are no additional conditions that should be included in this Permit to take account of the Section 4 duty.

(ii) Section 7 (Pursuit of Conservation Objectives)

We considered whether we should impose any additional or different requirements in terms of our duty to have regard to the various conservation objectives set out in Section 7, but concluded that we should not.

We have considered the impact of the installation on local wildlife sites within 2Km which are not designated as either European Sites or SSSIs. We are satisfied that no additional conditions are required.

(iii) Section 81 (National Air Quality Strategy)

We have had regard to the National Air Quality Strategy and consider that our decision complies with the Strategy, and that no additional or different conditions are appropriate for this Permit.

### 7.2.2 Human Rights Act 1998

We have considered potential interference with rights addressed by the European Convention on Human Rights in reaching our decision and consider that our decision is compatible with our duties under the Human Rights Act 1998. In particular, we have considered the right to life (Article 2), the right to a fair trial (Article 6), the right to respect for private and family life (Article 8) and the right to protection of property (Article 1, First Protocol). We do not believe that Convention rights are engaged in relation to this determination.

### 7.2.3 Countryside and Rights of Way Act 2000 (CROW 2000)

Section 85 of this Act imposes a duty on Environment Agency to have regard to the purpose of conserving and enhancing the natural beauty of the area of outstanding natural beauty (AONB).

### 7.2.4 Wildlife and Countryside Act 1981

Under section 28G of the Wildlife and Countryside Act 1981 the Environment Agency has a duty to take reasonable steps to further the conservation and enhancement of the flora, fauna or geological or physiographical features by reason of which a site is of special scientific interest. Under section 28I the

Environment Agency has a duty to consult Natural England in relation to any permit that is likely to damage SSSIs.

There are no designated SSSI's within the relevant screening distances.

#### **7.2.5 Natural Environment and Rural Communities Act 2006**

Section 40 of this Act requires us to have regard, so far as is consistent with the proper exercise of our functions, to the purpose of conserving biodiversity. We have done so and consider that no different or additional conditions in the Permit are required.

### **7.3 National secondary legislation**

#### **7.3.1 The Conservation of Natural Habitats and Species Regulations 2010**

We have assessed the Application in accordance with guidance agreed jointly with Natural England / CCW and concluded that there will be no likely significant effect on any European Site.

#### **7.3.2 Water Framework Directive Regulations 2003**

Consideration has been given to whether any additional requirements should be imposed in terms of the Environment Agency's duty under regulation 3 to secure the requirements of the Water Framework Directive through (inter alia) EP permits, but it is felt that existing conditions are sufficient in this regard and no other appropriate requirements have been identified.

#### **7.3.3 The Persistent Organic Pollutants Regulations 2007**

We have explained our approach to these Regulations, which give effect to the Stockholm Convention on POPs and the EU's POPs Regulation, above.

### **7.5 Other relevant legal requirements**

#### **7.5.1 Duty to Involve**

S23 of the Local Democracy, Economic Development and Construction Act 2009 require us where we consider it appropriate to take such steps as we consider appropriate to secure the involvement of interested persons in the exercise of our functions by providing them with information, consulting them or involving them in any other way. S24 requires us to have regard to any Secretary of State guidance as to how we should do that.

The way in which the Environment Agency has consulted with the public and other interested parties is set out in section 2 of this document. The way in which we have taken account of the representations we have received is set out in Annex 4. Our public consultation duties are also set out in the EP

Regulations, and our statutory Public Participation Statement, which implement the requirements of the Public Participation Directive. In addition to meeting our consultation responsibilities, we have also taken account of our guidance in Environment Agency Guidance Note RGS6 and the Environment Agency's Building Trust with Communities toolkit.

**ANNEX 1: APPLICATION OF CHAPTER IV OF THE INDUSTRIAL EMISSIONS DIRECTIVE**

<b>IED Article</b>	<b>Requirement</b>	<b>Delivered by</b>
45(1)(a)	The permit shall include a list of all types of waste which may be treated using at least the types of waste set out in the European Waste List established by Decision 2000/532/EC, if possible, and containing information on the quantity of each type of waste, where appropriate.	Condition 2.3.3 and Table S2.2 in Schedule 2 of the Permit
45(1)(b)	The permit shall include the total waste incinerating or co-incinerating capacity of the plant.	Condition 2.3.3 and Table S2.2 in Schedule 2 of the Permit
45(1)(c)	The permit shall include the limit values for emissions into air and water.	Condition 2.3.3 and Table S2.2 in Schedule 2 of the Permit
45(1)(d)	The permit shall include the requirements for pH, temperature and flow of waste water discharges.	There are no such discharges
45(1)(e)	The permit shall include the sampling and measurement procedures and frequencies to be used to comply with the conditions set for emissions monitoring.	Conditions 3.5.1 and Tables S3.1, S3.1(a), S3.2, S3.3 also compliance with Articles 10 and 11
45(1)(f)	The permit shall include the maximum permissible period of unavoidable stoppages, disturbances or failures of the purification devices or the measurement devices, during which the emissions into the air and the discharges of waste water may exceed the prescribed emission limit values.	Conditions 2.3.6 to 2.3.12
46(1)	Waste gases shall be discharged in a controlled way by means of a stack the height of which is calculated in such a way as to safeguard human health and the environment.	Emissions and their ground-level impacts are discussed in the body of this document,
46(2)	Emission into air shall not exceed the emission limit values set out in parts 4 or determined in accordance with part 4 of Annex VI.	Conditions 3.1.1 and 3.1.2 and Tables S3.1 and S3.1a

IED Article	Requirement	Delivered by
46(3)	Relates to conditions for water discharges from the cleaning of exhaust gases.	There are no such discharges as condition 3.1.1 prohibits this.
46(4)	Relates to conditions for water discharges from the cleaning of exhaust gases.	There are no such discharges as condition 3.1.1 prohibits this.
46(5)	Prevention of unauthorised and accidental release of any polluting substances into soil, surface water or groundwater. Adequate storage capacity for contaminated rainwater run-off from the site or for contaminated water from spillage or fire-fighting.	The application explains the measures to be in place for achieving the directive requirements
46(6)	Limits the maximum period of operation when an ELV is exceeded to 4 hours uninterrupted duration in any one instance, and with a maximum cumulative limit of 60 hours per year. Limits on dust (150 mg/m <sup>3</sup> ), CO and TOC not to be exceeded during this period.	Condition 2.3.11. and Table S3.1(a)
47	In the event of breakdown, reduce or close down operations as soon as practicable. Limits on dust (150 mg/m <sup>3</sup> ), CO and TOC not to be exceeded during this period.	condition 2.3.10
48(1)	Monitoring of emissions is carried out in accordance with Parts 6 and 7 of Annex VI.	Condition 3.5 and Schedule 7 details this standardisation requirement
48(2)	Installation and functioning of the automated measurement systems shall be subject to control and to annual surveillance tests as set out in point 1 of Part 6 of Annex VI.	condition 3.5.3, and tables S3.1, S3.1(a),
48(3)	The competent authority shall determine the location of sampling or measurement points to be used for monitoring of emissions.	tables s4.1
48(4)	All monitoring results shall be	

IED Article	Requirement	Delivered by
	recorded, processed and presented in such a way as to enable the competent authority to verify compliance with the operating conditions and emission limit values which are included in the permit.	
49	The emission limit values for air and water shall be regarded as being complied with if the conditions described in Part 8 of Annex VI are fulfilled.	
50(1)	Slag and bottom ash to have Total Organic Carbon (TOC) < 3% or loss on ignition (LOI) < 5%.	(a) Conditions 3.5.1 and Table S3.4
50(2)	Flue gas to be raised to a temperature of 850°C for two seconds, as measured at representative point of the combustion chamber.	(b) - Pre-operational condition PO5 and IC4. The application specifies measurement point
50(3)	At least one auxiliary burner which must not be fed with fuels which can cause higher emissions than those resulting from the burning of gas oil liquefied gas or natural gas.	(c) Condition 2.3.8
50(4)(a)	Automatic shut to prevent waste feed if at start up until the specified temperature has been reached.	Condition 2.3.7
50(4)(b)	Automatic shut to prevent waste feed if the combustion temperature is not maintained.	Condition 2.3.7
50(4)(c)	Automatic shut to prevent waste feed if the CEMs show that ELVs are exceeded due to disturbances or failure of waste cleaning devices.	Condition 2.3.7
50(5)	Any heat generated from the process shall be recovered as far as practicable.	(a) The plant will generate electricity (b) Operator to review the available heat recovery options prior to commissioning (Condition PO4) and then every 2 years
50(7)	Management of the Installation to be in the hands of a natural person who is competent to manage it.	Conditions 1.1.1 to 1.1.3 and 2.3.1 of the Permit fulfil this requirement
51(1)	Different conditions than those laid down in Article 50(1), (2) and (3)	No such conditions Have been allowed



IED Article	Requirement	Delivered by
	and, as regards the temperature Article 50(4) may be authorised, provided the other requirements of this chapter are met.	
52(1)	Take all necessary precautions concerning delivery and reception of Wastes, to prevent or minimise pollution.	<ul style="list-style-type: none"> <li>- EPR require prevent or minimise pollution.</li> <li>-Volume 3 of the Application defines how this will be carried out.</li> <li>- conditions 2.3.1, 2.3.3, 2.3.2, 2.3.3 and 2.3.4</li> </ul>
52(2)	Determine the mass of each category of wastes, if possible according to the EWC, prior to accepting the waste.	Volume 2 of the application describes procedures for the reception and monitoring of incoming waste
53(1)	Residues to be minimised in their amount and harmfulness, and recycled where appropriate.	condition 3.5.1
53(2)	Prevent dispersal of dry residues and dust during transport and storage.	conditions 2.3.1, 2.3.2 and 3.2.1
53(3)	Test residues for their physical and chemical characteristics and polluting potential including heavy metal content (soluble fraction).	Condition 3.5.1
55(1)	Application, decision and permit to be publicly available.	Documents will be available on our public register
55(2)	An annual report on plant operation and monitoring for all plants burning more than 2 tonne/hour waste.	Condition 4.2.2

## ANNEX 2: Pre-Operational Conditions

Based on the information on the Application, we consider that we do need to impose pre-operational conditions. These conditions are set out below and referred to, where applicable, in the text of the decision document. We are using these conditions to require the Operator to confirm that the details and measures proposed in the Application have been adopted or implemented prior to the operation of the Installation.

Reference	Pre-operational measures
PO1	Prior to the commencement of commissioning, the Operator shall send a summary of the site Accident Management Plan to the Environment Agency and make available for inspection all documents and procedures which form part of the plan.
PO2	Prior to the commencement of commissioning, the Operator shall submit a written report to the Agency detailing the waste acceptance procedure to be used at the site. The waste acceptance procedure shall include the process and systems by which wastes unsuitable for incineration at the site will be controlled. The procedure shall be implemented in accordance with the written approval from the Agency.
PO3	Prior to the commencement of commissioning, the Operator shall send a summary of the site Environment Management System (EMS) to the Environment Agency and make available for inspection all documents and procedures which form part of the EMS. The EMS shall be developed in line with the requirements set out in Section 1 of How to comply with your environmental permit – Getting the basics right. The documents and procedures set out in the EMS shall form the written management system referenced in condition 1.1.1 (a) of the permit.
PO4	Prior to the commencement of commissioning, the Operator shall send a report to the Environment Agency which will contain a comprehensive review of the options available for utilising the heat generated by the waste incineration process in order to ensure that it is recovered as far as practicable. The review shall detail any identified proposals for improving the recovery and utilisation of waste heat and shall provide a timetable for their implementation.
PO5	After completion of furnace design and at least three calendar months before any furnace operation; the operator shall submit a written report to the Agency of the details of the computational fluid dynamic (CFD) modelling. The report shall demonstrate whether the design combustion conditions comply with the residence time and temperature requirements as defined by the Waste Incineration Directive.
PO6	Prior to the commencement of commissioning; the Operator shall provide a written commissioning plan, including timelines for completion, for approval by the Environment Agency. The commissioning plan shall include the expected emissions to the environment during the different stages of commissioning, the expected durations of commissioning activities and the actions to be taken to protect the environment and report to the Environment Agency in the event that actual emissions exceed expected emissions. Commissioning shall be carried out in accordance with the commissioning plan as approved.

### ANNEX 3: Improvement Conditions

Based in the information in the Application we consider that we need to set improvement conditions. These conditions are set out below - a justification for these is provided at the relevant section of this decision document. We are using these conditions to require the Operator to provide the Environment Agency with details that need to be established or confirmed during and/or after commissioning.

Reference	Improvement measure	Completion date
IC1	The Operator shall submit a written report to the Environment Agency on the implementation of its Environmental Management System and the progress made in the certification of the system by an external body or if appropriate submit a schedule by which the EMS will be certified.	Within 12 months of the date on which waste is first processed.
IC2	The Operator shall submit a written proposal to the Environment Agency to carry out tests to determine the size distribution of the particulate matter in the exhaust gas emissions to air from the exhaust stack, identifying the fractions within the PM <sub>10</sub> , and PM <sub>2.5</sub> ranges. The proposal shall include a timetable for approval by the Environment Agency to carry out such tests and produce a report on the results. On receipt of written agreement by the Environment Agency to the proposal and the timetable, the Operator shall carry out the tests and submit to the Environment Agency a report on the results.	Within 6 months of the completion of commissioning.
IC3	The Operator shall submit a written report to the Environment Agency on the commissioning of the installation. The report shall summarise the environmental performance of the plant as installed against the design parameters set out in the Application. The report shall also include a review of the performance of the facility against the conditions of this permit and details of procedures developed during commissioning for achieving and demonstrating compliance with permit conditions.	Within 4 months of the completion of commissioning.
IC4	The Operator shall carry out checks to verify the residence time, minimum temperature and oxygen content of the exhaust gases in the furnace whilst operating under the anticipated most unfavourable operating conditions. The results shall be submitted in writing to the Environment Agency.	Within 4 months of the completion of commissioning.

Reference	Improvement measure	Completion date
IC5	<p>The Operator shall submit a written report to the Environment Agency describing the performance and optimisation of the Selective Non Catalytic Reduction (SNCR) system and combustion settings to minimise oxides of nitrogen (NO<sub>x</sub>) emissions within the emission limit values described in this permit with the minimisation of nitrous oxide emissions. The report shall include an assessment of the level of NO<sub>x</sub> and N<sub>2</sub>O emissions that can be achieved under optimum operating conditions.</p> <p>The report shall also provide details of the optimisation (including dosing rates) for the control of acid gases and dioxins</p>	Within 4 months of the completion of commissioning.
IC6	<p>The Operator shall carry out an assessment of the impact of emissions to air of [all] the [following] component metals subject to emission limit values, i.e. Cd, Tl, Hg, Sb, As, Pb, Cr, Co, Cu, Mn, Ni and V (<i>only include those metals which do not screen out in section 5.2.3</i>). A report on the assessment shall be made to the Environment Agency.</p> <p>Emissions monitoring data obtained during the first year of operation shall be used to compare the actual emissions with those assumed in the impact assessment submitted with the Application. An assessment shall be made of the impact of each metal against the relevant EQS/EAL. In the event that the assessment shows that an EQS/EAL can be exceeded, the report shall include proposals for further investigative work.</p>	15 months from commencement of operations
IC7	The Operator shall submit a written summary report to the Agency to confirm by the results of calibration and verification testing that the performance of Continuous Emission Monitors for parameters as specified in Table S3.1 and Table S3.1(a) complies with the requirements of BS EN 14181, specifically the requirements of QAL1, QAL2 and QAL3.	<p>Initial calibration report to be submitted to the Agency within 3 months of completion of commissioning.</p> <p>Full summary evidence compliance report to be submitted within 18 months of commissioning.</p>

## ANNEX 4: Consultation Responses

### A) Advertising and Consultation on the Application

The Application has been advertised and consulted upon in accordance with the Environment Agency's Public Participation Statement. The way in which this has been carried out along with the results of our consultation and how we have taken consultation responses into account in reaching our draft decision is summarised in this Annex. Copies of all consultation responses have been placed on the Environment Agency and Local Authority public registers.

The Application was advertised on the Environment Agency website from 14<sup>th</sup> November to 19<sup>th</sup> December 2014. Copies of the Application were placed on the Environment Agency Public Register at, Environment Agency, Trentside Office, Nottingham.

The following statutory and non-statutory bodies were consulted: -

- Public Health England.
- Local Authority – Environmental Health Protection Department.
- Local Authority – Planning Department
- Food standards Agency.
- Health and Safety Executive.
- National Grid.
- Sewage Undertaker

### 1) Consultation Responses from Statutory and Non-Statutory Bodies

Response Received from - Public Health England	
Brief summary of issues raised:	Summary of action taken / how this has been covered
Public Health England – No significant concerns regarding the risk to the health of the local population from the installation based on the information contained within the application.  This assumption is based that the permit holder shall take all reasonable appropriate measures to prevent or cause pollution, in accordance with the relevant sector guidance and industry best practice.	No action Needed  The data supplied in the Application regarding potential emissions from the installation have been verified by the Agency.

Response Received from Nottingham City Council – Environmental Health & Local planning

Brief summary of issues raised:	Summary of action taken / how this has been covered
<p>Nottingham City Council advised that during their consideration of the Application for Planning Permission, objection were raised by Friends of the Earth and Nottinghamshire Wildlife Trust (NWT). As a consequence of the NWT objection a condition was included in the granted permission (dated 02/07/14) to ensure the protection of local nature reserves.</p> <p>Planning permission was granted with on-going regulatory conditions to minimise the noise / disturbance that the development has the potential to cause.</p> <p>Nottingham City Council points out their consideration and observations of the Initial Site Condition Survey submitted as part of the Planning Application. In their opinion the report and proposals meet the general requirements to prevent pollution contamination of the site.</p> <p>NCC expressed concerns about odour nuisance potential from the installation once operational, from waste storage and the processing of that waste.</p>	<p>No response was received by the Environment Agency from either organisation in respect to the Environmental Permit Application. Section 5.4 of this document explains how we have assessed the potential impact of emissions from the installation on site of conservation and following our full assessment of the application and its potential to affect the site(s) habitat has been carried out as part of the permitting process. We consider that the application will not affect the features of the site/species/habitat.</p> <p>The Environment Agency carried out its own assessment and check modelling of the potential for noise pollution from the installation. Section 6.5.5 of this document explains how, Based upon the information in the application we are satisfied that the appropriate measures will be in place to prevent or where that is not practicable to minimise noise and vibration and to prevent pollution from noise and vibration outside the site.</p> <p>The Applicant also submitted a Site Condition Report as part of their Environmental Permit Application. The Environment Agency also agrees that the land and groundwater will be adequately protected.</p> <p>The Application states the physical and technical design measures that will be taken by the Operator to eliminate or minimise the potential of the facility to cause an odour nuisance. The Applicant submitted an Odour Management Plan which we consider will achieve this. The Permit</p>

<p>NCC stated that they are satisfied that the development will not have an impact upon air quality as defined under the provisions of the Environment Act 1995. They had noted that the Applicant was proposing emissions limit values for both NO<sub>2</sub> and SO<sub>2</sub> below the maximum permitted by the Industrial Emissions Directive.</p>	<p>also contains specific conditions which allow the Environment Agency to regulate the site to prevent Odour issues and complaint.</p> <p>As explained in sections 5.2, Air Quality Assessment and 6.6 Setting of ELVs we agree with the observations of NCC and have set maximum emission limits in the permit for both NO<sub>x</sub> and SO<sub>2</sub> in line with the maximum expected emission values proposed and assessed by the Applicant.</p>
---	---

Response Received from – Health and Safety Executive	
Brief summary of issues raised:	Summary of action taken / how this has been covered
No comments to make on this Application.	No action needed

Response Received from – Sewage Undertaker – Severn Trent Water Ltd.	
Brief summary of issues raised:	Summary of action taken / how this has been covered
<p>The Applicant does not currently hold a Trade Effluent Consent, or Agreement with Severn Trent Water Ltd. Therefore the Operator will need to submit a Trade Effluent Notice to the Sewage Undertaker to pursue the appropriate authorisation.</p>	<p>Applicant notified, but was aware of the need to make such a submission prior to operation of the facility.</p>
<p>Severn Trent Water Ltd. Confirmed that the proposed site is located outside known groundwater Source Protection Zones, and therefore has no comment regarding risk to their groundwater sources.</p>	<p>No action needed.</p>