



Tunnel Presentation

Tim Smart
27th June 2016

Tunnel Briefing Agenda

1. Operational aspects of tunnels

- (1) Safety arrangements
- (2) Noise and vibration
- (3) Vent shafts and smoke control
- (4) Energy use in tunnels

2. Construction

- (1) Tunnelling techniques
- (2) Shaft construction
- (3) Settlement
- (4) Construction aspects

3. Costs implications

- (1) Costs of tunnelling



Tunnel Locations



Tunnels Phase One

Twin Bored Tunnel

Euston	<ul style="list-style-type: none">• 7.4km• London Clay
Northholt	<ul style="list-style-type: none">• 14km• London Clay/Lambeth/Chalk
Chilterns	<ul style="list-style-type: none">• 15.8km• Chalk
Long Itchington Wood	<ul style="list-style-type: none">• 1.5km• Penarth Group/Mercia Mudstone
Bromford	<ul style="list-style-type: none">• 2.8km• Penarth Group/Mercia Mudstone

Cut & Cover

Wendover	<ul style="list-style-type: none">• 1.4km• Chalk
Greatworth	<ul style="list-style-type: none">• 2.1km• Glacial Till/Oolite/Whitby Mudstone
Chipping Warden	<ul style="list-style-type: none">• 2.5km• Low Jurassic Marlstone/Mudstone
Long Itchington Wood	<ul style="list-style-type: none">• 0.4km• Penarth Group/Mercia Mudstone
Burton Green	<ul style="list-style-type: none">• 0.5km• Lower Carboniferous Mudstone

1. Operational Aspects of Tunnelling

(1) Safety Arrangements

(2) Noise and Vibration

(3) Vent Shafts and Smoke Control

(4) Energy use in Tunnels

1.(1) Minimum Safety Requirements (TSI)

Place of relative safety

- If to the surface every 1 km
- To adjacent independent tunnel tube every 500m

Fire Fighting Points - *Applies to all tunnels over 1 km and rolling stock dependent*

- Tunnel Length 1 to 5 km at portals with minimum standing area 550 sq m
- Tunnels over 5km at every 5km depending on rolling stock characteristics

Fire Fighting Point *defined as*

- Location inside or outside tunnel where fire fighting equipment can be used and passengers can evacuate
- Water Supply capacity is a minimum of 800 l/min for 2 hrs.

1.(1) Tunnel Cross Passage

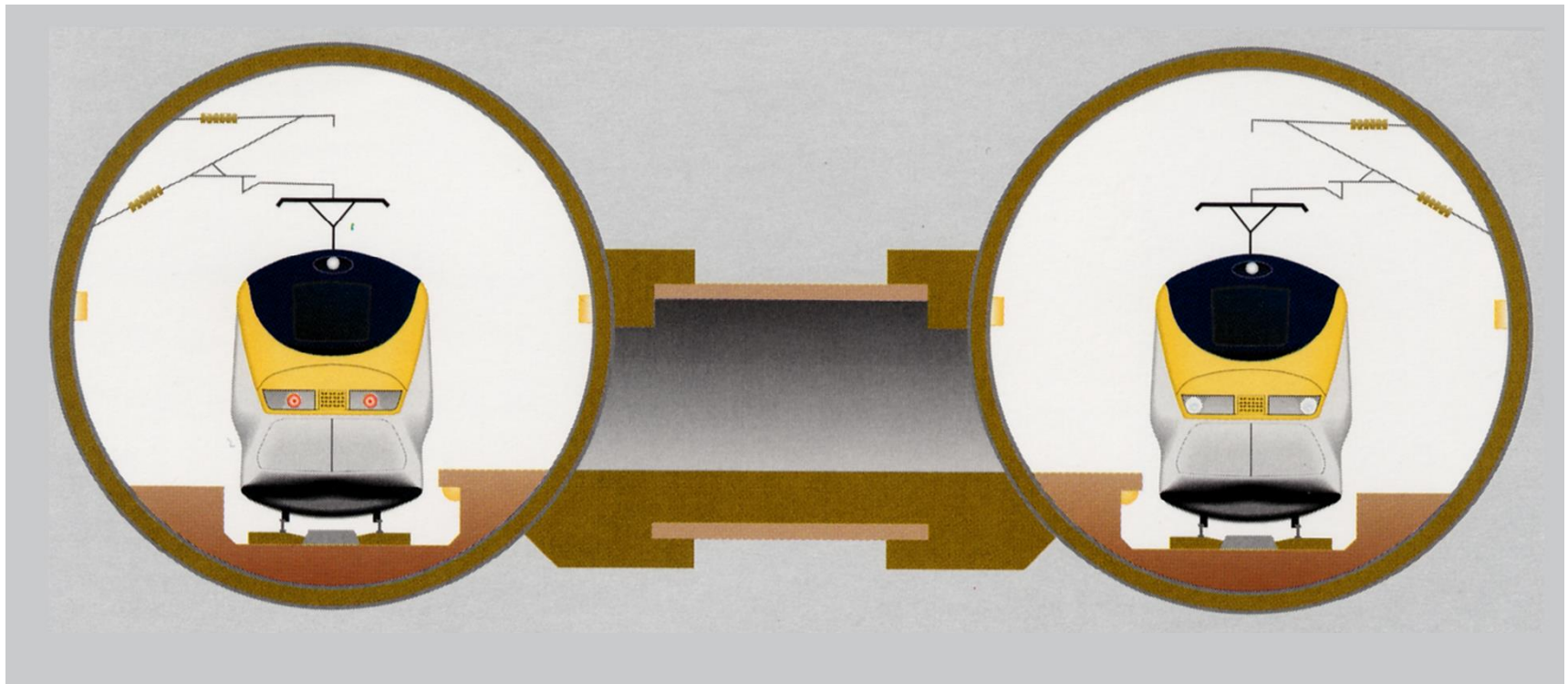

1.(1) Emergency Train Evacuation

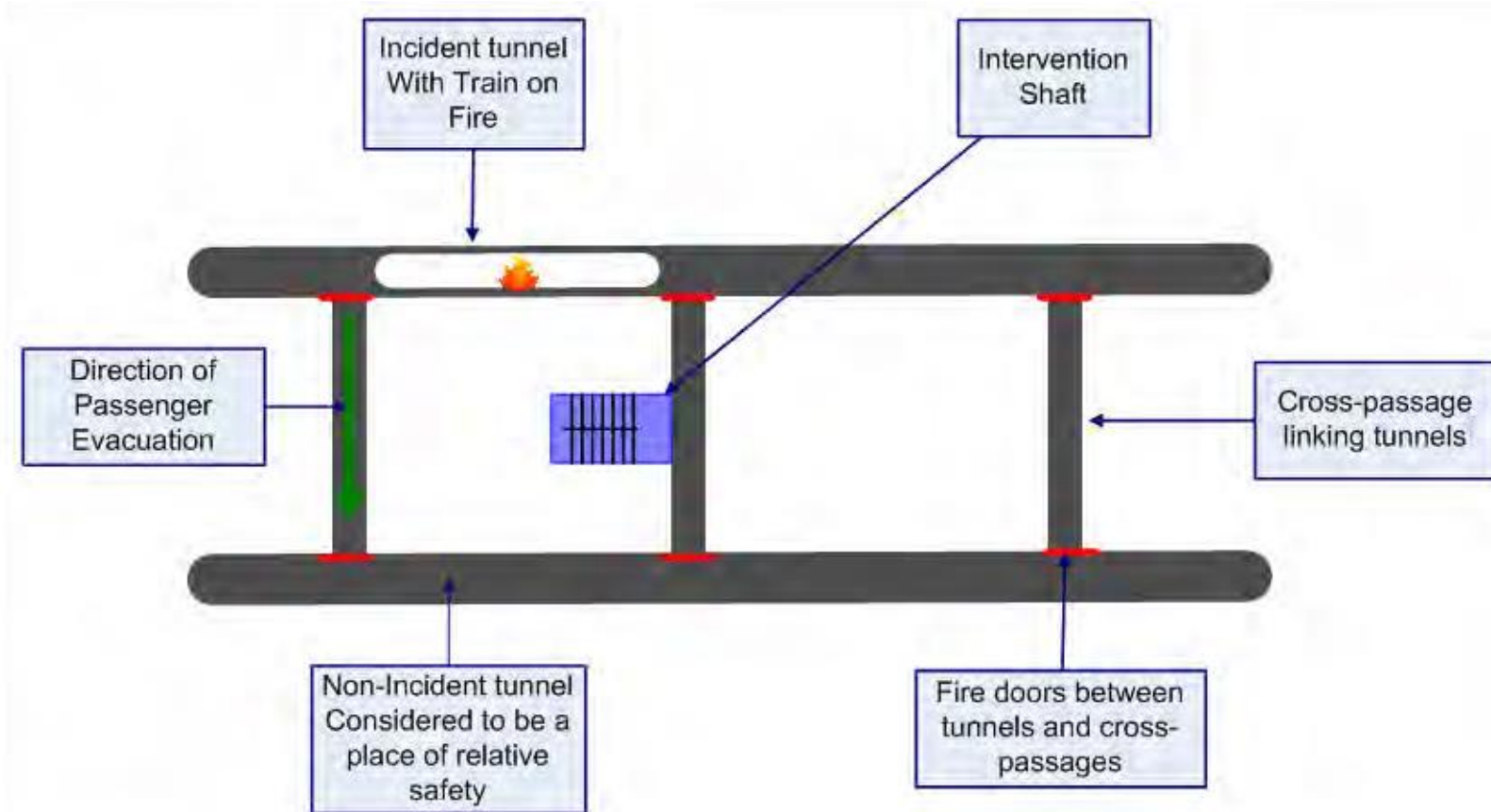

1.(1) Evacuation Walkway & Tunnel Cross Passage Opening HS1



1.(1) Intervention Gap

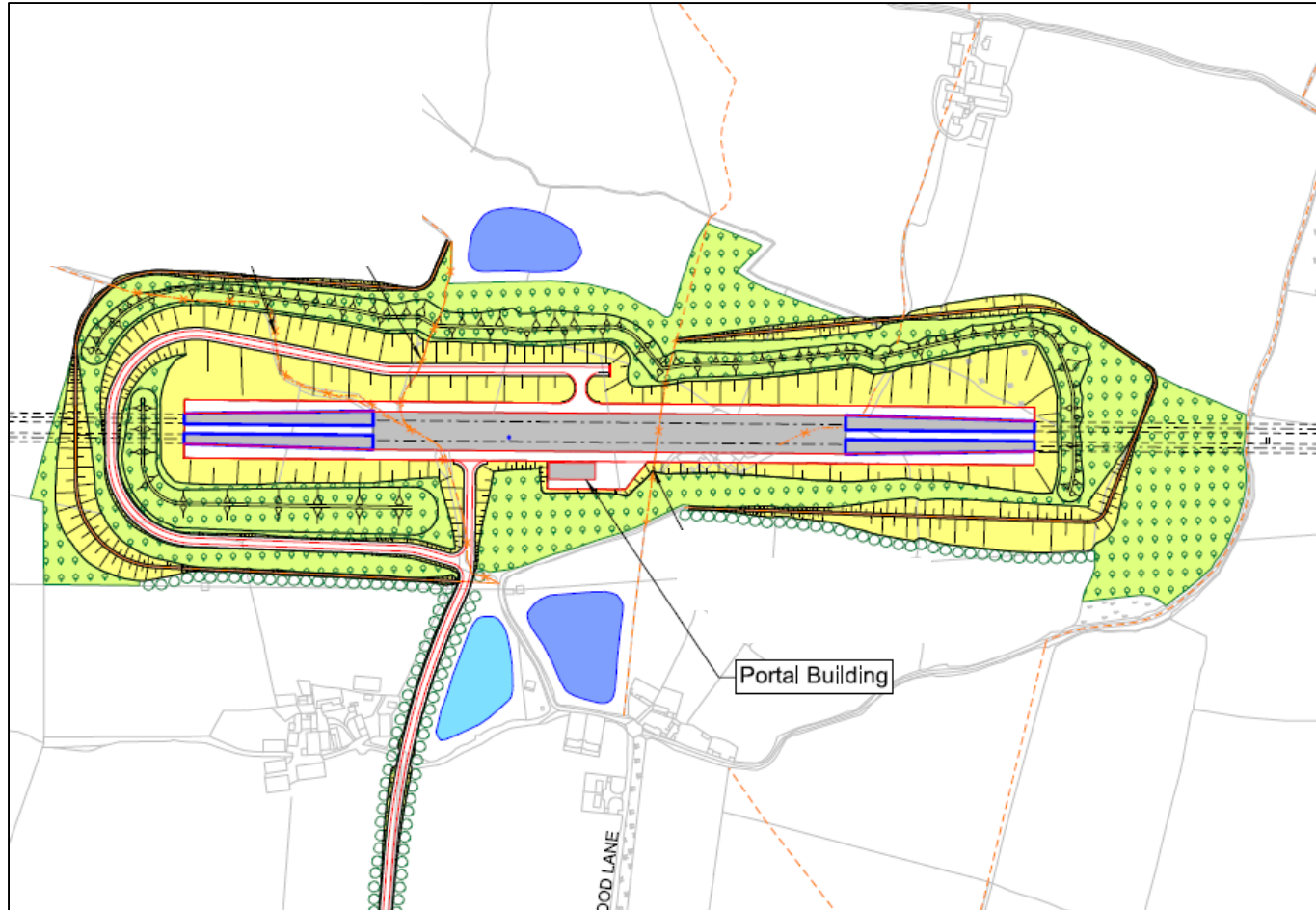

1. (2) Noise and Vibration

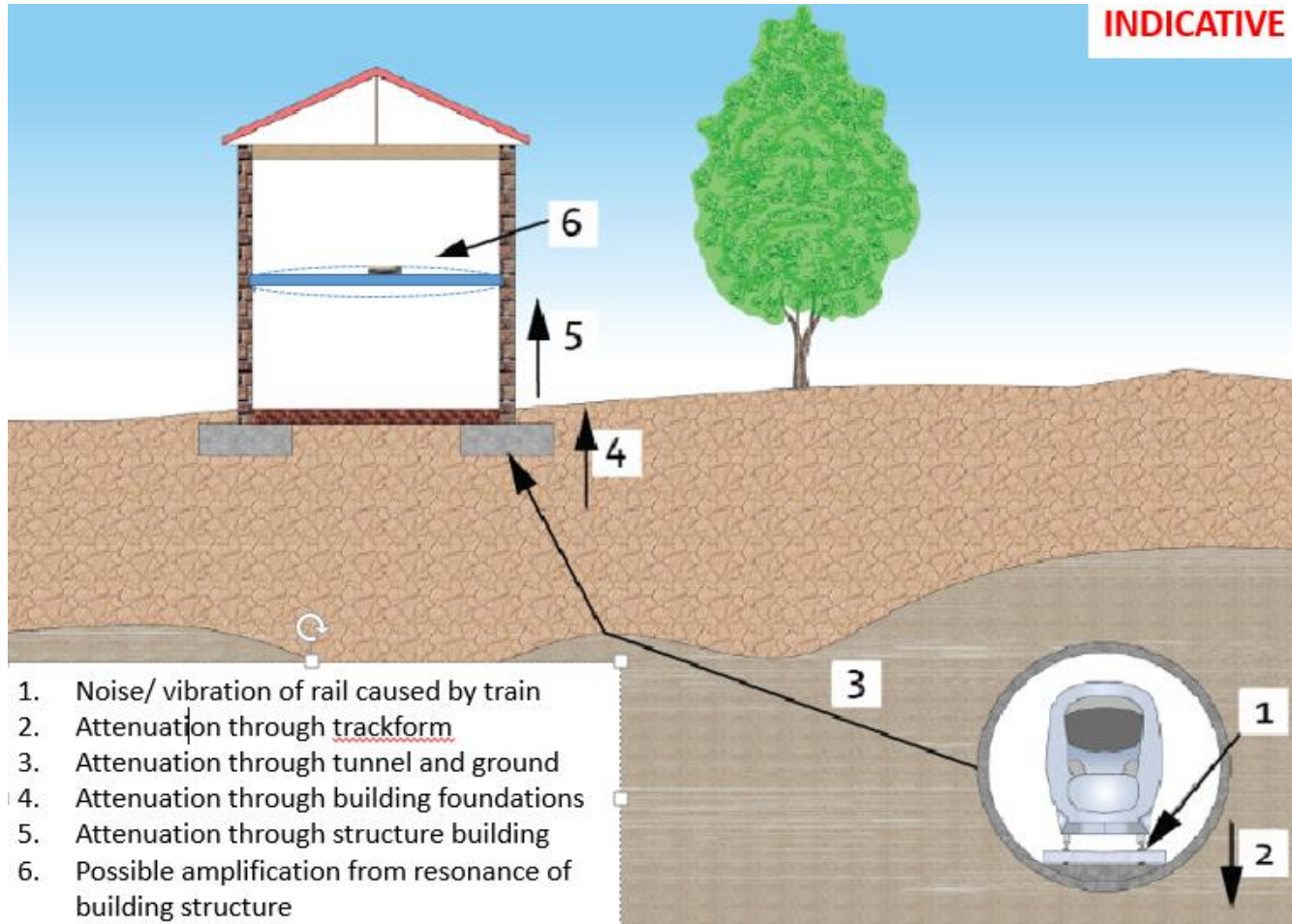

1. (2) Vibration mitigation via "booted sleeper" track



1. (2) Vent Shafts and Operational Noise

HS2 vent shafts are designed, constructed operated and maintained along with their associated stationary equipment so that noise in the worst affected residential receptors conforms to British Standard guidance and achieves the aims of the Noise Policy Statement for England.

Mechanical equipment within the vent shaft is only operated under the following circumstances;

- During and emergency
- During maintenance when required to maintain an acceptable air quality environment.
- During tunnel congestion when required to maintain an acceptable air quality environment.

1.(3) Vent Shafts and Smoke Control

Primary Purpose

- Smoke extract and control.
- Pressure relief
- Access for emergency services.
- Passenger comfort to keep air quality and temperature within acceptable limits.

Secondary Uses

- Tunnel boring machine maintenance intervention.
- Access for railway maintenance.

1.(3) Vent Shafts along Bored Tunnels

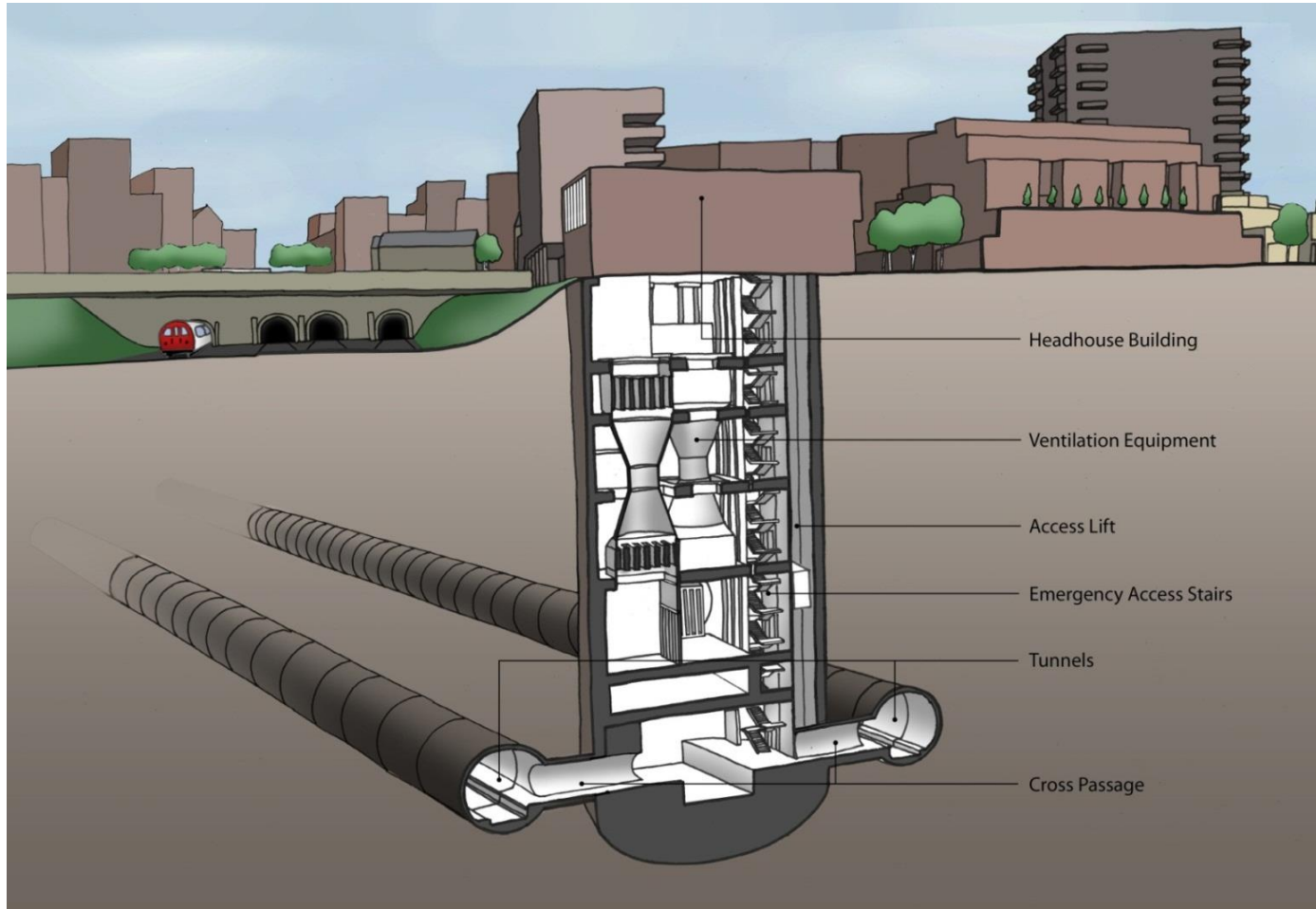

1. (4) Energy use in Tunnels

Traction power

- Energy required for the traction power of the trains increases in tunnels.
- In the open air 80% of the energy used by the train goes into overcoming air resistance. This increases to 90% in a tunnel.

Increased power for Mechanical and Electrical plant and equipment

- Increase in energy costs for the railway due to the plant necessary for safety arrangements (e.g fans, lifts, fire mains, emergency lighting plus tunnel integrity plant (e.g pumps, cooling arrangements)

2. Construction

- (1) Tunnelling techniques
- (2) Shaft construction
- (3) Settlement
- (4) Construction aspects

2.(1) Construction

Types of Tunnelling Techniques Applicable to HS2

- **Bored Tunnels**
 - Shield type machines with precast segmental tunnel lining.
 - Used when surface access is very limited at depths typically below one tunnel diameter.
 - Longer tunnel lengths where economical to use machine.
- **Cut & Cover Tunnels (“Green Tunnels”)**
 - Typically concrete box structures constructed in excavated ground.
 - Used at shallower depths where there is good surface access.
- **Mined/Sprayed Concrete Lining Tunnels**
 - Mechanically excavated by with sprayed concrete lining.
 - Used in shorter drives or more complicated shapes. Also in soft rock ground conditions.

2.(1) Bored Tunnels

Earth Pressure Balance Tunnel Boring Machine (EPBM)

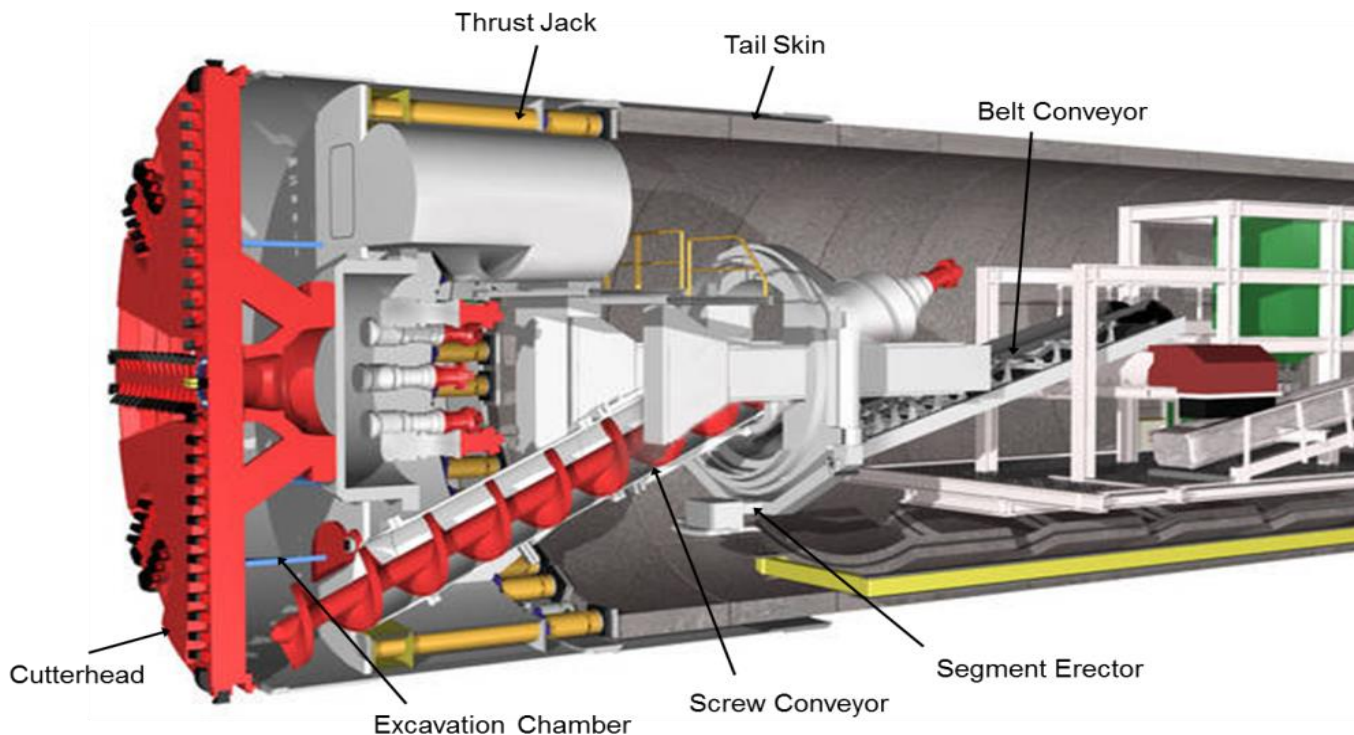

2.(1) Bored Tunnels

HS1 EPBM in factory showing back up arrangements



2.(1) Bored Tunnels

Slurry or “Hydroshield” Tunnel Boring Machine

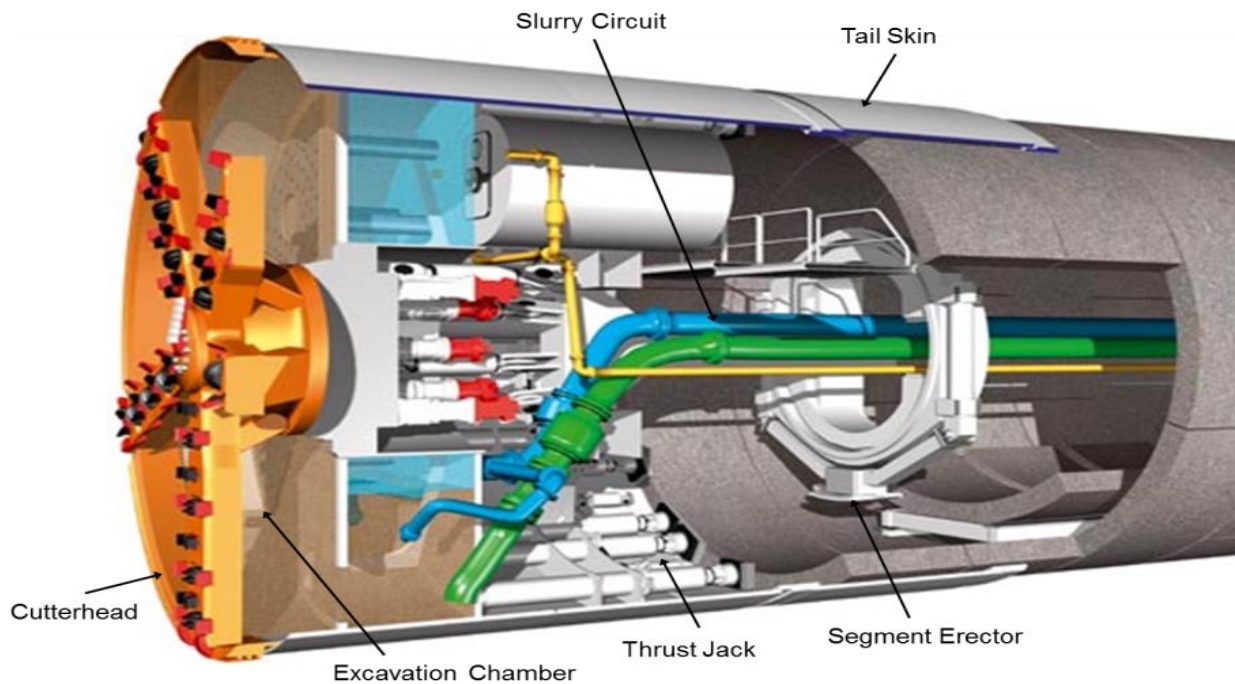

2.(1) Segment Yard & Drive Site Locations

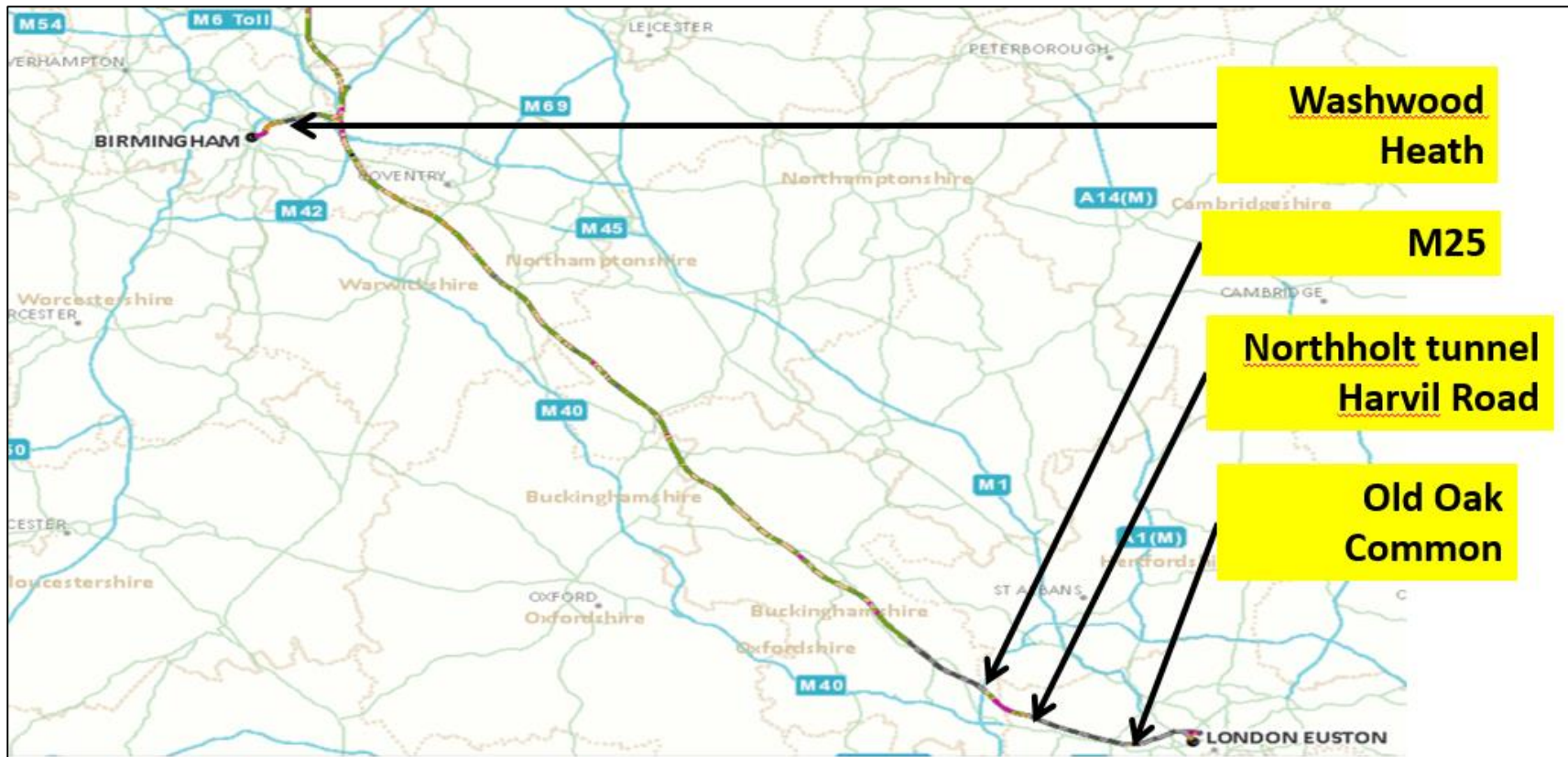

2.(1) Precast Tunnel Lining Manufacture



2.(1) Construction Plan - West Hyde

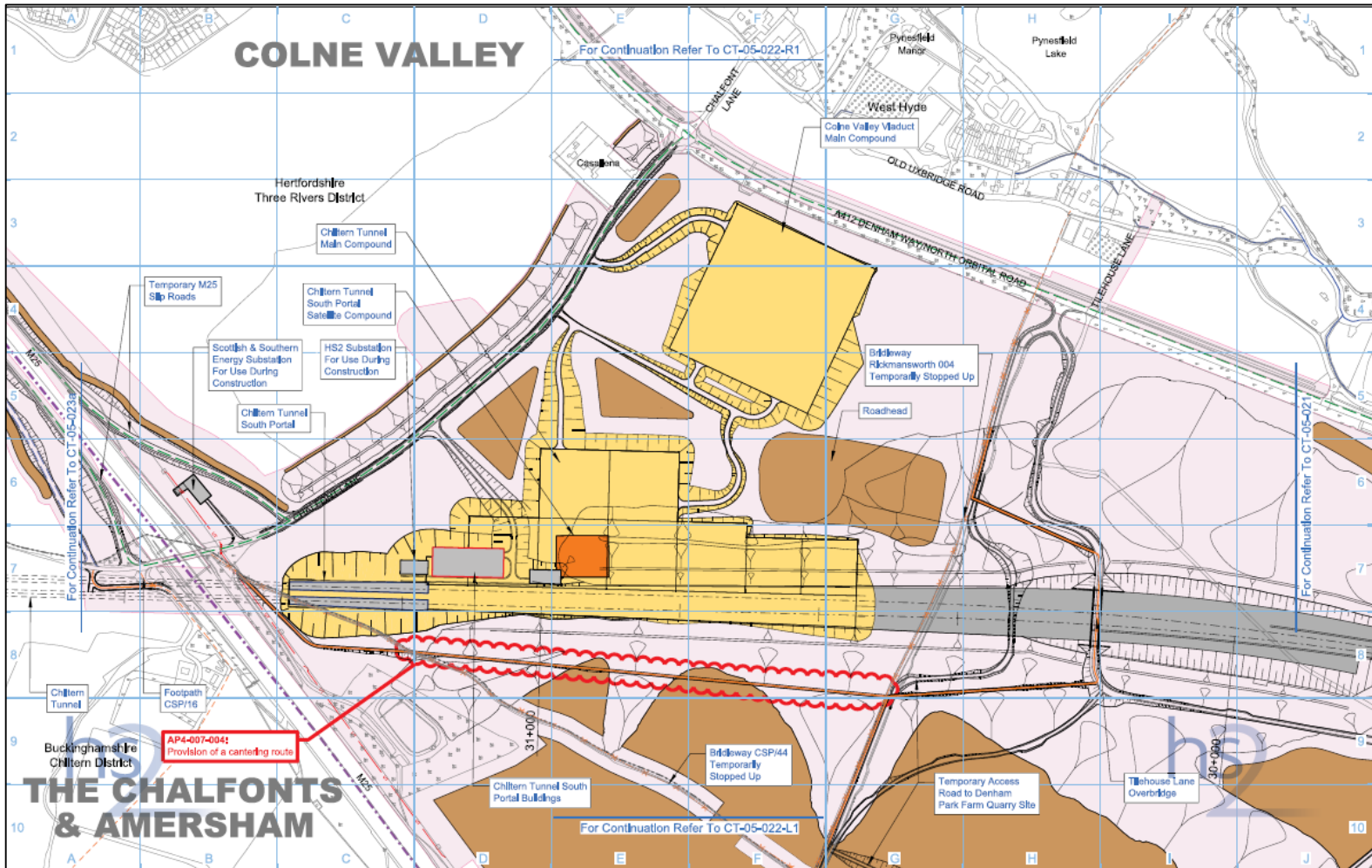

2.(1) Construction Plan – South Heath

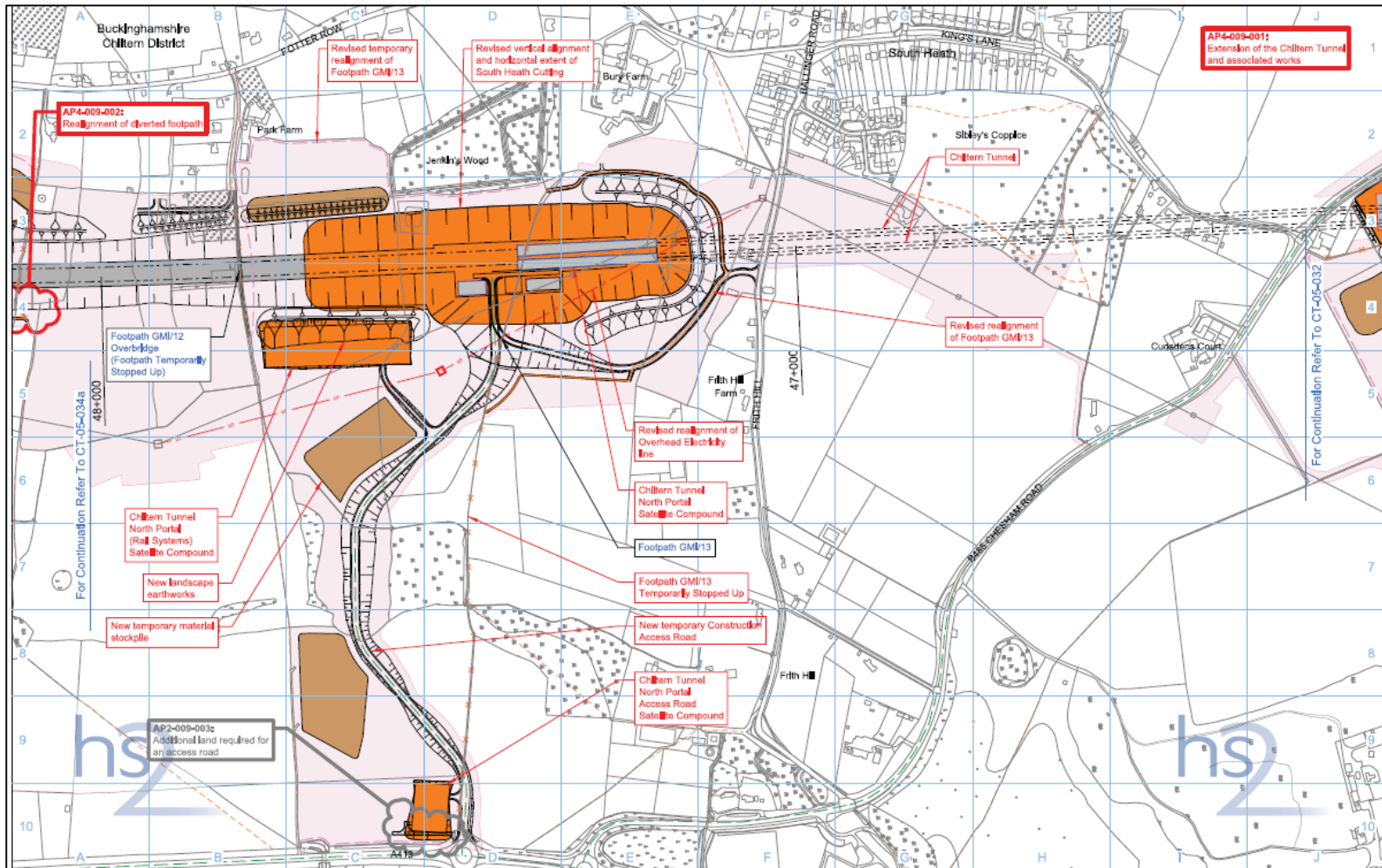

2.(1) Types of Tunnel: Mined tunnel

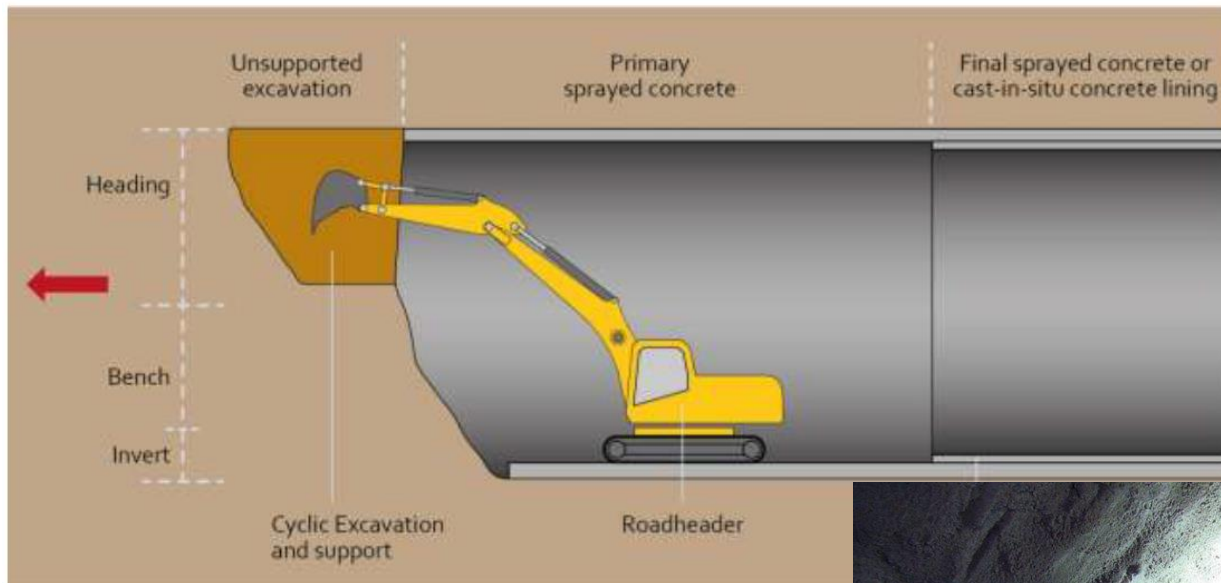

2.(1) Cut and Cover Construction Methodology 1

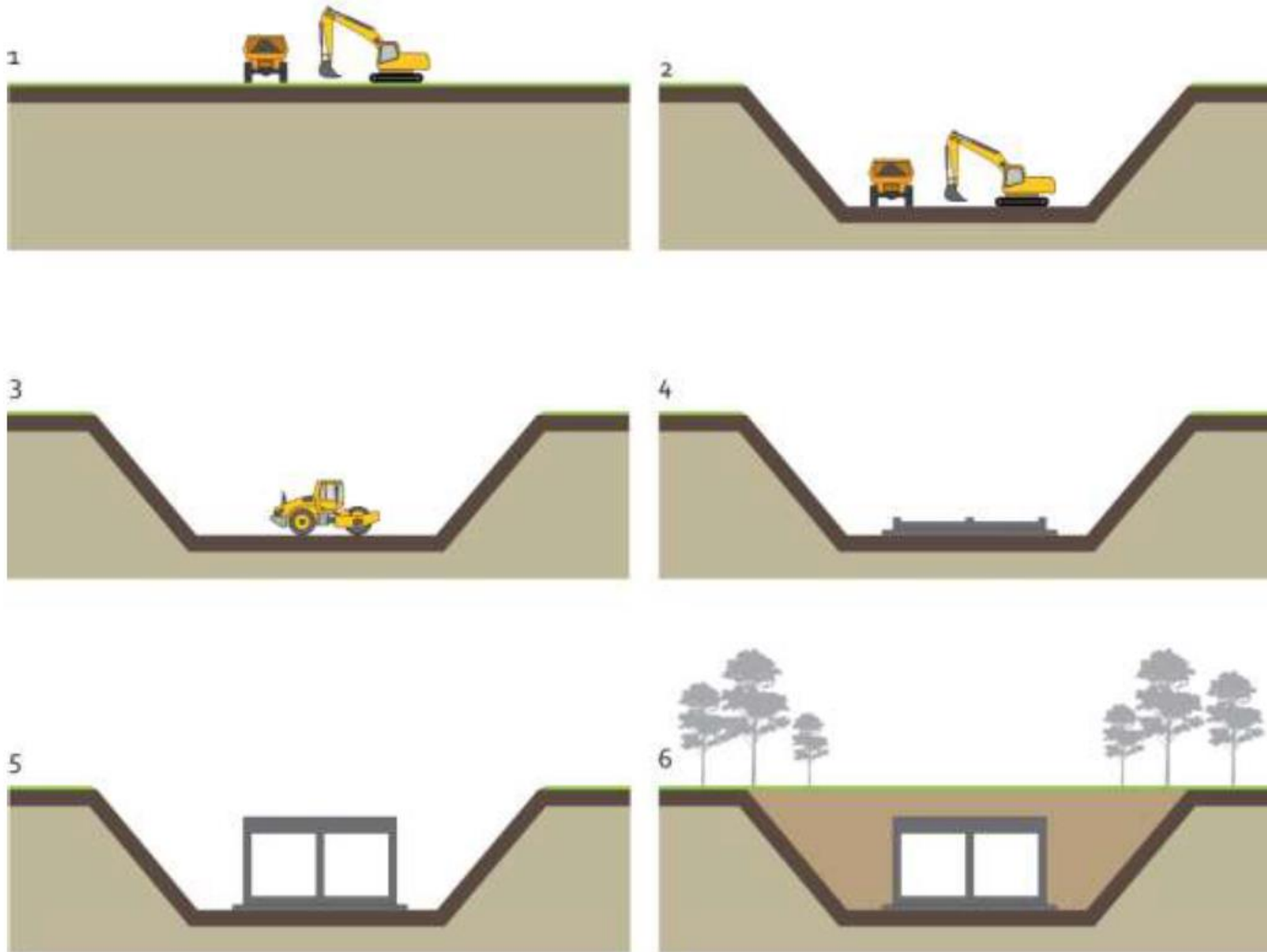

2. (1) HS1 Cut and Cover Tunnel



2. (1) Cut and Cover Construction Methodology 2

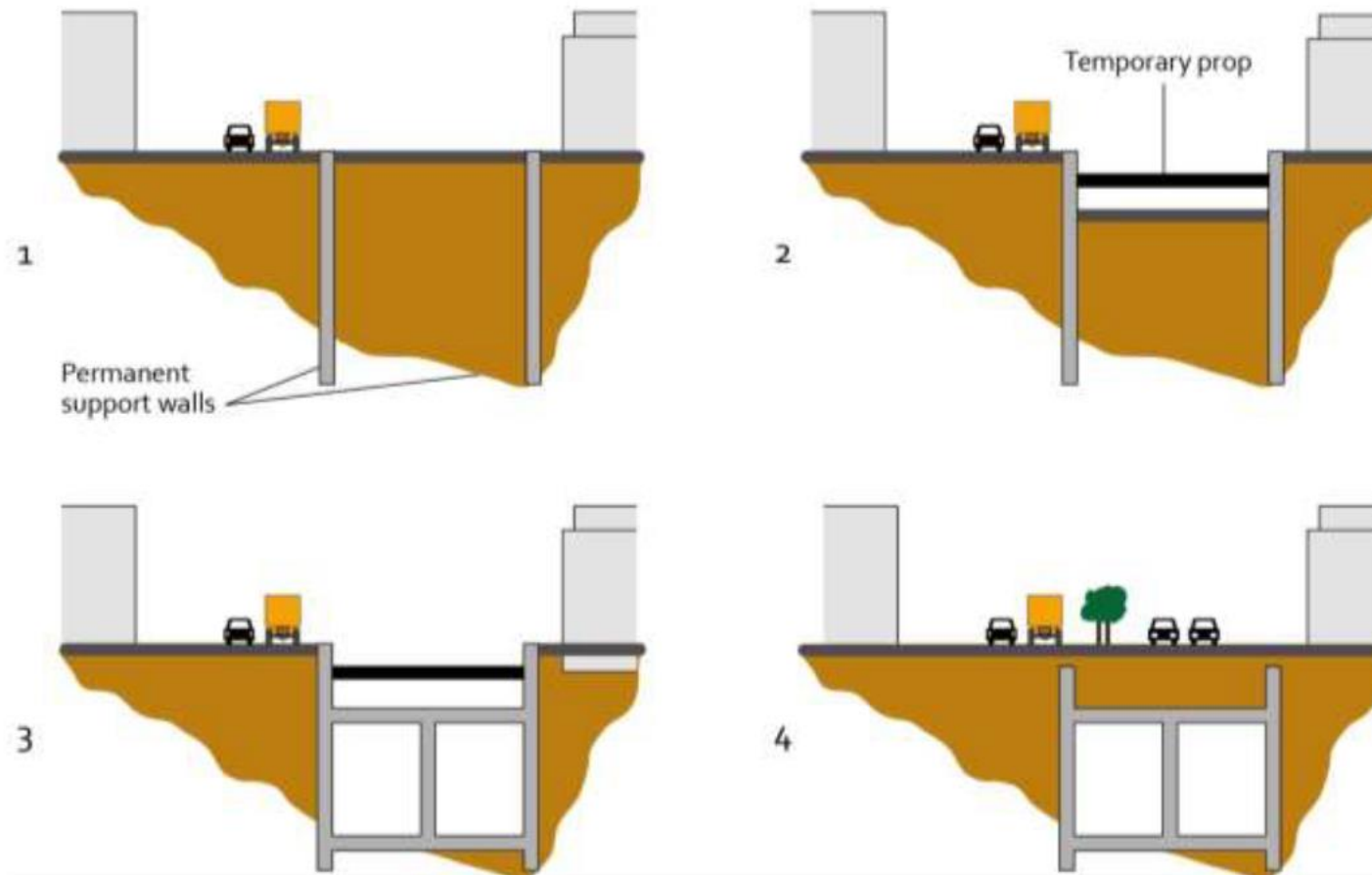

2. (1) D-wall Construction



2.(2) Shaft Construction



2.(3) Settlement

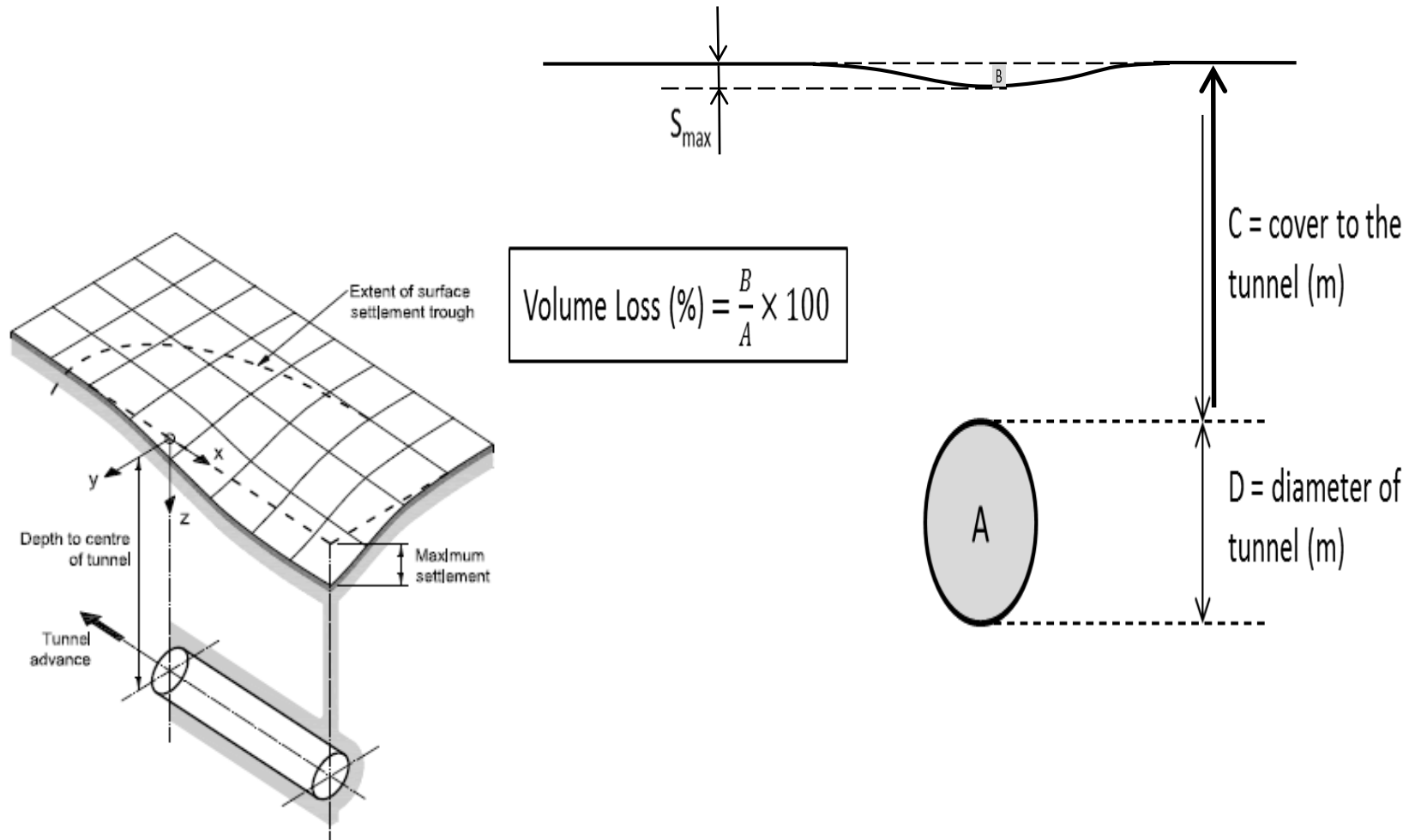

INDICATIVE

P1509 (32)

2.(3) Settlement & Rate of Tunnelling

The rate of tunnelling will be important in minimising settlement. This is achieved by operating tunnel boring machines appropriately such as using Earth Pressure Balance machines in “closed” mode.

In order to keep settlement to acceptable limits HS2 has specified maximum of 1% volume loss for bored tunnels.

Continuous 24 hour tunnelling also minimises settlement as it doesn't allow time for the for the ground to fully relax.

Other methods of controlling settlement include grouting techniques, particularly compensation grouting.

2.(3) Settlement and Protective Measures

The primary form of settlement mitigation will be by good tunnelling practice, including continuous working. Where required additional measures (e.g. grouting and structural solutions) will be carried out based on a three stage assessment as set out in Information Paper C3 Ground Settlement.

Phase 1 Assessment: A preliminary assessment based on “green field” conditions will be undertaken. Where the predicted settlement is less than 10 mm or less than 1/500 slope, no further assessment required.

Phase 2 Assessment: In the case of predicted settlement of more than 10mm or 1/500 slope an individual building assessment will be carried out. If the potential damage classification is category 2 (slight) or below no further assessment is required.

Phase 3 Assessment: Where predicted settlement indicates potential damage classification of 3 (moderate) or higher a detailed evaluation will be carried out with the aim to reduce the effects to acceptable levels. Where this is not possible further protective measures will be implemented.

Settlement Deed. Properties within 30 metres of tunnels may apply for a Deed as set out in information paper C3 to ensure that protective measures are implemented in accordance with the assessment criteria.

2.(4) Construction Aspects – Noise Tunnel Drive Sites

Tunnel drive sites generate similar noise levels to other large construction sites.

Tunnelling activities and the associated local site material handling will be operated 24 hours a day.

Noise mitigation is provided by the standard means such as hoarding, muffling, baffles and noise suppression on plant and equipment .

Tunnel sites will be subject to the same HS2 procedures set out under the Code of Construction practice and will be subject to Local Authority Approval under Section 61 of CoPA.

2.(4) Construction Aspects – Noise Tunnel Boring

Sound and vibration from the tunnel boring machine will be perceptible inside properties for a few days either side of the TBM as it passes beneath them.

The effects of ground-borne sound and vibration from the TBM on building occupants will be short-term and hence they are not considered to be significant.

3. Costs of Tunnelling

Fixed Costs

- TBM typically £15 to £25m
- Back up material handling similar costs order
- Power supply

Linear Costs

- Labour
- Lining materials
- Excavated material disposal
- Ground monitoring
- Ground treatment
- Tunnel logistics

Incremental Cost increases

- Surface arrangements for drive sites, reception sites, portal arrangements
- Increase in number of shafts
- Increase in number of cross passages;
- Shaft and tunnel M&E systems.

Cost vs. Length

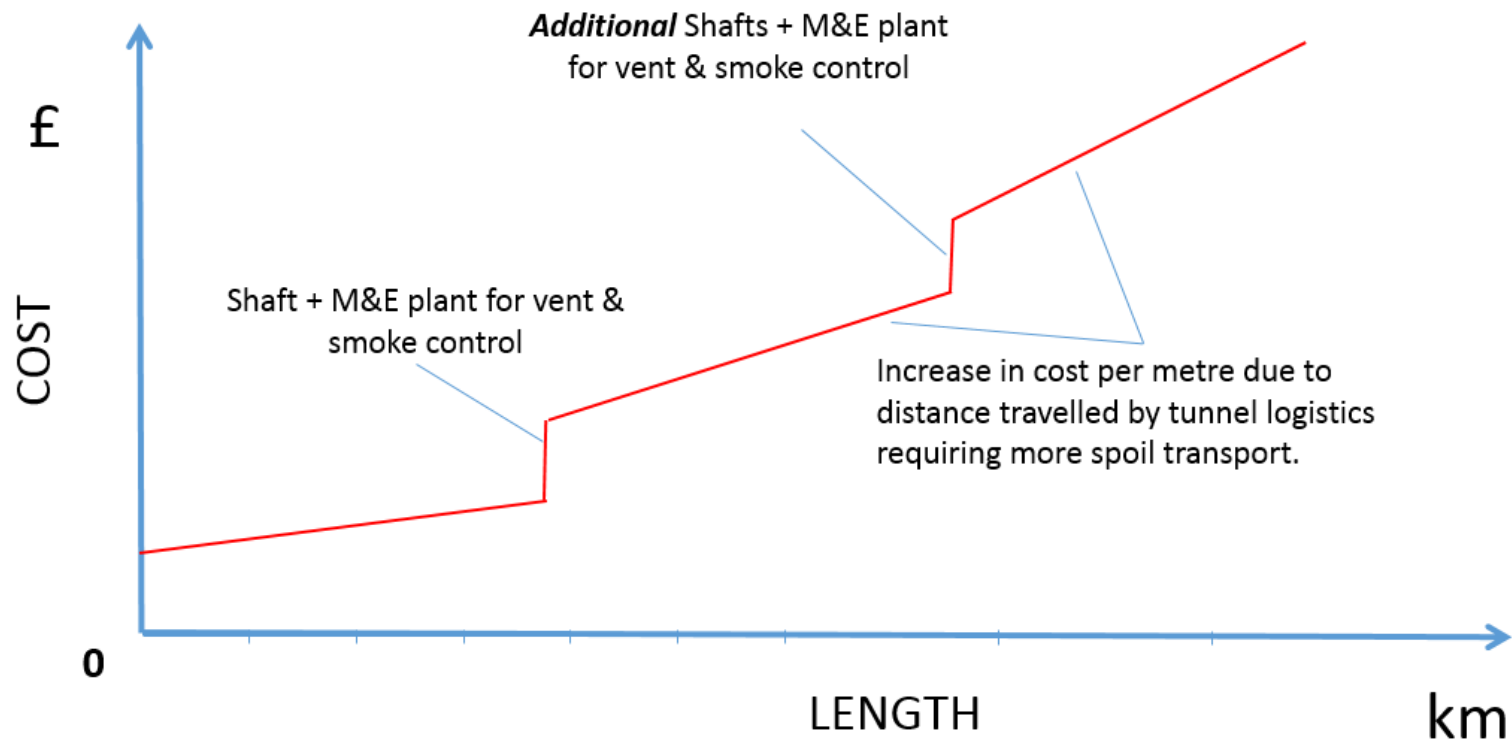

INDICATIVE



Thank you
