



Rail Accident Investigation Branch

Rail Accident Report



Parting of the live overhead wire at Walkergate station, Tyne and Wear Metro 11 August 2014

Report 09/2015
July 2015

This investigation was carried out in accordance with:

- the Railway Safety Directive 2004/49/EC;
- the Railways and Transport Safety Act 2003; and
- the Railways (Accident Investigation and Reporting) Regulations 2005.

© Crown copyright 2015

You may re-use this document/publication (not including departmental or agency logos) free of charge in any format or medium. You must re-use it accurately and not in a misleading context. The material must be acknowledged as Crown copyright and you must give the title of the source publication. Where we have identified any third party copyright material you will need to obtain permission from the copyright holders concerned. This document/publication is also available at www.raib.gov.uk.

Any enquiries about this publication should be sent to:

RAIB	Email: enquiries@raib.gov.uk
The Wharf	Telephone: 01332 253300
Stores Road	Fax: 01332 253301
Derby UK	Website: www.gov.uk/raib
DE21 4BA	

This report is published by the Rail Accident Investigation Branch, Department for Transport.

Preface

The purpose of a Rail Accident Investigation Branch (RAIB) investigation is to improve railway safety by preventing future railway accidents or by mitigating their consequences. It is not the purpose of such an investigation to establish blame or liability. Accordingly, it is inappropriate that RAIB reports should be used to assign fault or blame, or determine liability, since neither the investigation nor the reporting process has been undertaken for that purpose.

The RAIB's findings are based on its own evaluation of the evidence that was available at the time of the investigation and are intended to explain what happened, and why, in a fair and unbiased manner.

Where the RAIB has described a factor as being linked to cause and the term is unqualified, this means that the RAIB has satisfied itself that the evidence supports both the presence of the factor and its direct relevance to the causation of the accident. However, where the RAIB is less confident about the existence of a factor, or its role in the causation of the accident, the RAIB will qualify its findings by use of the words 'probable' or 'possible', as appropriate. Where there is more than one potential explanation the RAIB may describe one factor as being 'more' or 'less' likely than the other.

In some cases factors are described as 'underlying'. Such factors are also relevant to the causation of the accident but are associated with the underlying management arrangements or organisational issues (such as working culture). Where necessary, the words 'probable' or 'possible' can also be used to qualify 'underlying factor'.

Use of the word 'probable' means that, although it is considered highly likely that the factor applied, some small element of uncertainty remains. Use of the word 'possible' means that, although there is some evidence that supports this factor, there remains a more significant degree of uncertainty.

An 'observation' is a safety issue discovered as part of the investigation that is not considered to be causal or underlying to the event being investigated, but does deserve scrutiny because of a perceived potential for safety learning.

The above terms are intended to assist readers' interpretation of the report, and to provide suitable explanations where uncertainty remains. The report should therefore be interpreted as the view of the RAIB, expressed with the sole purpose of improving railway safety.

The RAIB's investigation (including its scope, methods, conclusions and recommendations) is independent of any inquest or fatal accident inquiry, and all other investigations, including those carried out by the safety authority, police or railway industry.

Parting of the live overhead wire at Walkergate station, Tyne and Wear Metro, 11 August 2014

Contents

Preface	3
Summary	7
Introduction	8
Key definitions	8
The accident	9
Summary of the accident	9
Context	10
The investigation	17
Sources of evidence	17
Scope of the investigation	17
Key facts and analysis	18
Sequence of events	18
Identification of the immediate cause	21
Identification of causal factors	22
Identification of underlying factors	25
Factors affecting the severity of consequences	28
Observations	28
Summary of conclusions	31
Immediate cause	31
Causal factors	31
Underlying factors	31
Observations	31
Previous occurrences of a similar character and RAIB recommendations relevant to this investigation	32
Actions reported as already taken or in progress relevant to this report	34
Actions reported that address factors which otherwise would have resulted in a RAIB recommendation	34
Other reported actions	34
Recommendations	35

Appendices	36
Appendix A - Glossary of abbreviations and acronyms	36
Appendix B - Glossary of terms	37
Appendix C - Effect of increasing resistance on the size of current	39

Summary

At around 18:56 hrs on Monday 11 August 2014, a Tyne and Wear Metro train at Walkergate station, developed an electrical fault in equipment under the rear car, which tripped the power supply to the overhead wire. About a minute later, the power was remotely restored by a power controller and a fire started in the faulty equipment. The fault drew a high current from the overhead wire through the car's pantograph, causing localised overheating and, after about 18 seconds, the wire parted. The loose ends of the live wire flailed around the train roof, showering sparks, and one end fell on the platform. A second power controller happened to observe events on station CCTV and power to the overhead line was disconnected. The parted overhead wire had remained live for approximately 14 seconds.

At the time of the accident, the train doors were closed for departure and there were no passengers on the platform. About 30 passengers got out of the train after the power was turned off. There were no reported injuries, although passengers were evidently distressed.

A sustained high current was drawn because the electrical fault occurred in a part of the train's power circuit which was not protected by on-train equipment and which could only be detected by the overhead power supply protection equipment. However, because of the way that the power was switched back on, the level of current drawn by the fault was not sufficient to immediately activate that protection.

The underlying cause of the accident was the ineffective management of risks created at the interface between system components, comprising the power supply, power control and the train.

The RAIB observed that the arrangements between the infrastructure operator, Nexus, and the train operator, DB Regio Tyne and Wear, did not effectively facilitate the sharing of relevant health and safety information on risks created within the system. It also observed deficiencies in the competence management of the power control function and in the regime for assuring the continued integrity of some electrical protection equipment.

The RAIB has made three recommendations. The first, addressed to Nexus, seeks improvements in its safety management system to provide a more effective framework for the management of its shared risks. The second, addressed to both Nexus and DB Regio Tyne and Wear, relates to the identification and evaluation of risks created at the interfaces between their organisations. The third recommendation, addressed to both organisations, seeks to achieve more comprehensive power control procedures to facilitate safe decision-making.

Introduction

Key definitions

- 1 The report contains abbreviations and technical terms (shown in *italics* the first time they appear in the report). These are explained in appendices A and B.

The accident

Summary of the accident

- 2 At around 18:56 hrs on Monday 11 August 2014, an electrical fault on a Tyne and Wear Metro train at Walkergate station (figure 1) was detected by equipment protecting the overhead line power supply. This tripped (opened) the substation *circuit breakers* to disconnect the power to the fault. About a minute later, the *power controller* restored power to the overhead line and the electrical fault was re-established, causing *arcing* and a fire under the rear car (paragraph 14). The current drawn by the fault also caused localised heating and weakening of the overhead wire where it was in contact with the train's rear *pantograph*, and the wire parted.
- 3 The loose ends of the parted live wire flailed on the roof of the train, showering sparks, and one end fell on to the platform. A second power controller in the South Gosforth control room saw what was happening on station Closed circuit television (CCTV) and the power was manually disconnected. The parted overhead wire had remained live for approximately 14 seconds.
- 4 The accident occurred when the train doors were closed for departure and there were no passengers on the platform. About 30 passengers evacuated the train after the current was disconnected. No-one was reported as injured.
- 5 Staff in the control centre called the fire service who attended at around 19:04 hrs, by which time the fire was no longer burning. It was subsequently found that a train *line breaker* on the underside of the rear car had suffered burn damage and the parted contact wire had burned a hole in the roof of the leading car.
- 6 The Metro service was partially suspended until 05:47 hrs on 12 August for repairs to the overhead line and for the train to be recovered.

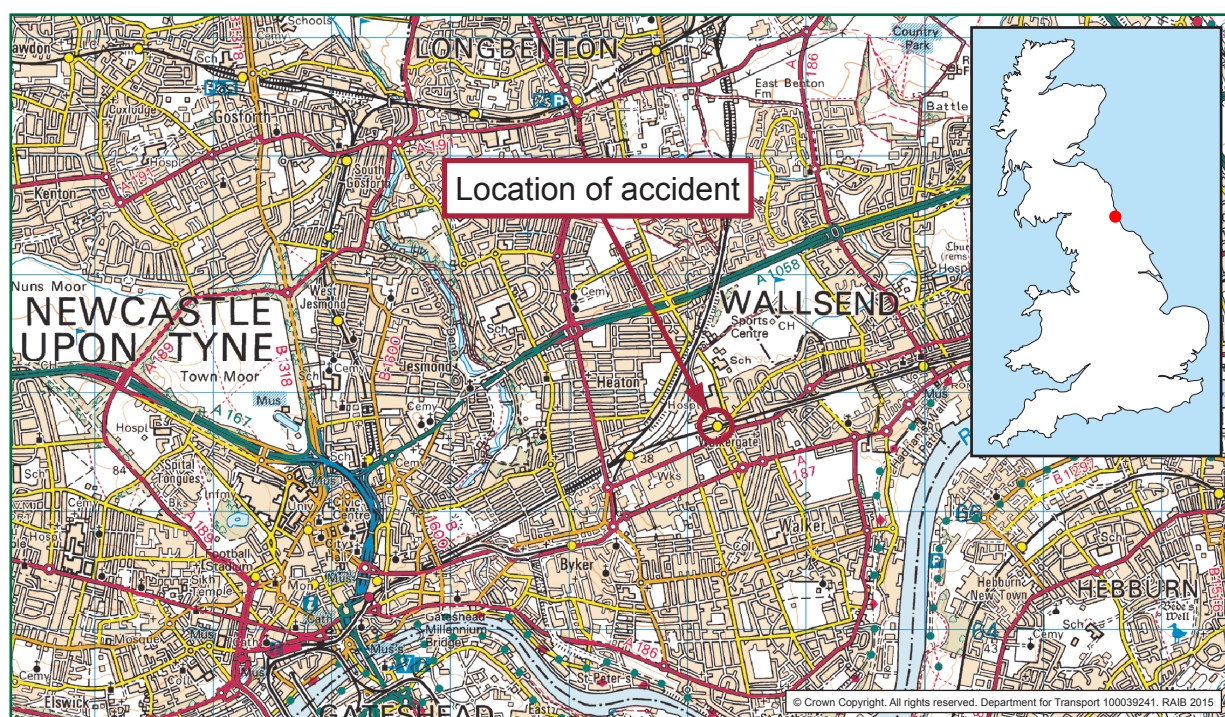

Figure 1: Extract from Ordnance Survey map showing location of accident

Context

Location

- 7 The accident occurred at Walkergate station on the outbound¹ Yellow Line of the Tyne and Wear Metro (figure 2). There are two tracks at this location. The station is unstaffed but can be observed in the control room at South Gosforth on CCTV.

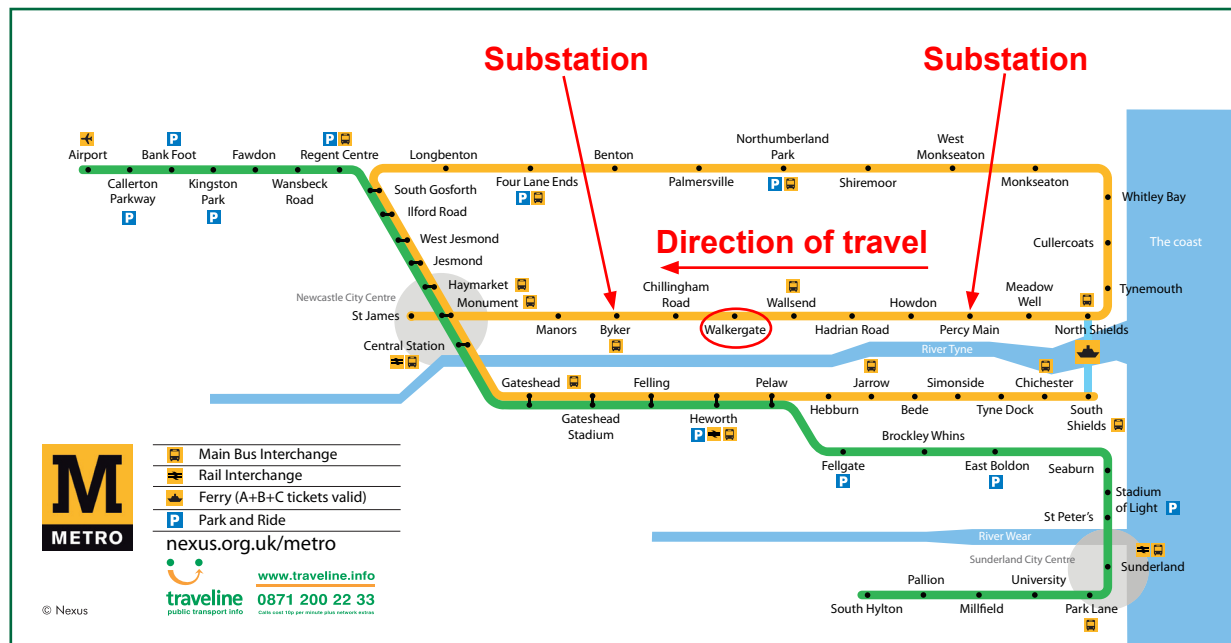

Figure 2: The Tyne and Wear Metro network (courtesy of Nexus)

Organisations involved

- 8 The Tyne and Wear Metro system is owned by the Tyne and Wear Passenger Transport Executive, which trades as Nexus.
- 9 Nexus is responsible for the provision and maintenance of the infrastructure, including the power supply system, on the Metro system (excluding the section from Pelaw to South Hylton which is owned and maintained by Network Rail) (figure 2).
- 10 DB Regio Tyne & Wear Ltd (DBTW) operates the Metro service under a seven-year concession from Nexus which commenced in 2010. The terms of this concession are recorded in a formal concession agreement.
- 11 DBTW is responsible for the operation and maintenance of the trains and the control of the overhead power supply. DBTW controls the power supply from the control centre at South Gosforth and maintains the trains at the Gosforth depot.
- 12 DBTW employs the driver and the power controllers.
- 13 Both Nexus and DBTW freely co-operated with the investigation.

¹ The clockwise direction of the Yellow Line from South Shields around the loop is St James, is known as the 'outbound' line.

Train involved

- 14 The train, reporting number 130, consisted of two cars, each made up of a two-section articulated unit (figure 3). The leading car was number 4010 and the trailing car, on which the electrical fire occurred, was 4090. These cars were built between 1978 and 1981 by Metro-Cammell, in Birmingham.

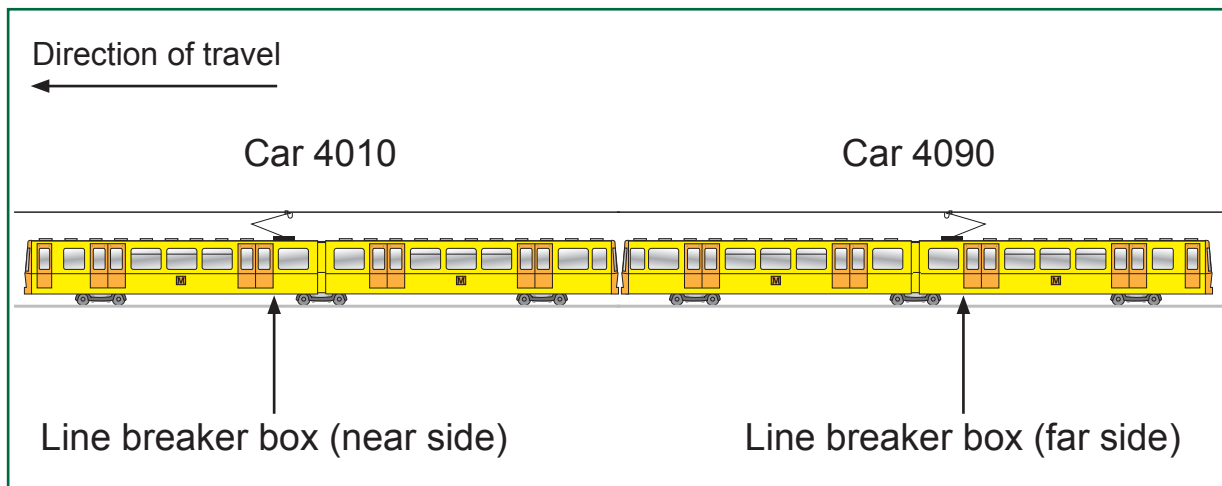

Figure 3: Arrangement of the train looking from the platform side

- 15 Metro trains are driver-only operated and have no other operations staff on board. On arrival at a station, the driver releases the doors on the platform side, which allows them to be opened from either inside or outside the train by pressing a button on the doors. When ready to depart, the driver closes the doors and carries out a final check to ensure that it is safe to depart. At most stations, including Walkergate, this is done with the aid of mirrors mounted on the platform adjacent to the stopping position of the driver's cab. The driver then drives the train out of the platform.

Rail equipment/systems involved

Electrical protection of the traction power supply system

- 16 Trains operating on the Metro system are supplied with 1500 Volt direct current (DC) traction power through overhead contact wires. There is a separate contact wire for each track, suspended at intervals by *droppers* from a catenary wire (figure 4). Trains draw traction current from the contact wire through pantographs mounted on the roof of each car and current is returned to the substations via the train's wheels and the running rails.
- 17 The section of overhead line which includes Walkergate station is supplied with traction power at each end of the electrical section from substations at Percy Main and Byker (figure 2). This is known as being 'double-end fed'. There is a separate feed for each of the two tracks. The Byker to Percy Main electrical section is 6,955 metres long; Walkergate station is 1,364 metres from Byker and 5,591 metres from Percy Main (figure 5).

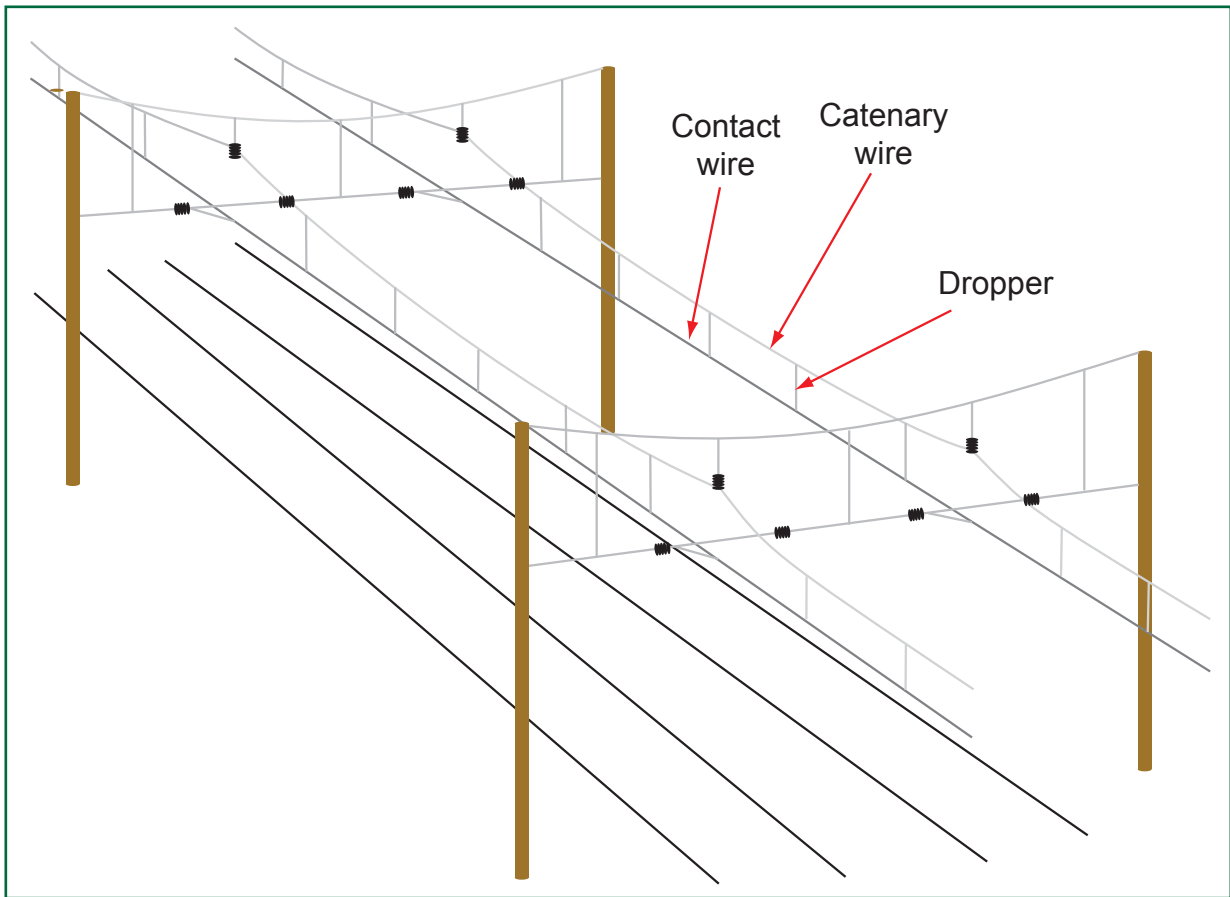

Figure 4: Generalised arrangement of overhead line equipment

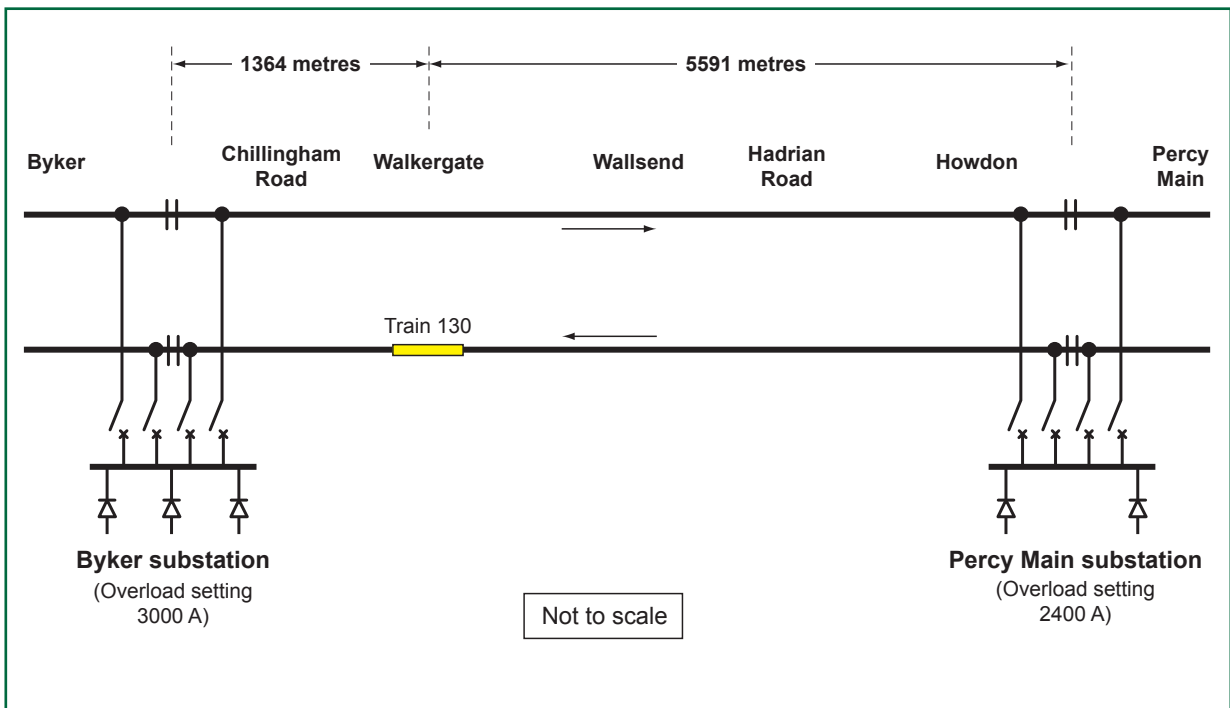

Figure 5: Percy Main to Byker electrical section

- 18 At the substations, traction power is fed to the overhead wires via circuit breakers which open automatically when an *overload* unit detects current being drawn in excess of designated overload settings. The circuit breakers can also be opened and closed manually by power controllers in the control room at South Gosforth. The circuit breakers at Percy Main and Byker were set to open at 2400 amperes (A) and 3000 A respectively².
- 19 On some long electrical sections, including the Byker to Percy Main section, line current *relays* were fitted around the mid-point of the section to assist the detection of electrical faults distant from the supply end. This is because the electrical resistance of the overhead line equipment reduces the size of a possible fault current as the distance from the supplying substation increases (see Appendix C for an explanatory diagram). The current drawn by faults a long way from the supplying substation may not, therefore, be sufficient to operate the substation overload protection. The mid-point line current relay detects the current flowing through it (in either direction) and is set to a value calculated to be less than the lowest *short circuit* fault level (typically 1500 A including a 10% safety margin). The line current relay operates if the current rises above 1500 A and causes the substation circuit breakers at both ends to open.
- 20 Some electrical faults, such as arcing faults, draw restricted short circuit currents which may be lower than both the overload settings of the substations' circuit breakers and of the mid-point line current relay. For this reason, a device known as a 'timed *overcurrent* trip' is provided as an additional safeguard. This will open the circuit breakers at each end of the electrical section if a current of more than 800 A is drawn continuously for a defined time, which in the Percy Main to Byker section, is 70 seconds. The settings of the timed overcurrent trip were established to distinguish sustained, restricted short circuits from the peak currents drawn by accelerating trains³. The timer starts as soon as it detects a current of more than 800 A, but stops as soon as the current drops below 800 A. A sustained current of more than 800 A can indicate that an electrical fault is occurring and, at the end of the defined time, the circuit breakers are opened.
- 21 The DC traction power supply protection arrangements were modified in about 1990 following two fires at Whitley Bay substation which were caused by an electrical fault in substation equipment. The electrical consultants involved in the original design of the system, recommended the fitting of *inter-tripping* equipment to protect substations from such faults. When a circuit breaker at one end of a double-end fed electrical section is tripped, inter-tripping equipment causes the circuit breaker at the opposite end to also open.

² The overload settings of the circuit breakers at Byker and Percy Main are different because Byker is a higher capacity substation.

³ A train accelerating from a stand usually draws a current of around 500 A for about 20 seconds but, as there may be more than one train in a section, a setting of 800 A has been selected to allow for this. The time of 70 seconds takes account of the length of the section and the normal frequency of trains. Other sections have shorter times. It is not uncommon for substation circuit breakers to be opened by the timed overcurrent trip as a result of an unintended 'bunching' of trains in an electrical section.

- 22 Although not its primary function, inter-tripping can also provide protection from faults in an electrical section when the section is fed from both ends. Such faults may be detected by the overload protection of the nearest supplying substation but, because of the distance involved (paragraph 19), not by the substation at the other end. In these circumstances, the inter-tripping equipment opens the circuit breaker at the remote end. A programme to upgrade the inter-tripping equipment, which proved to be unreliable in a previous accident at South Gosforth in 2013 ([RAIB report 18/2013](#)), was already underway at the time of that accident and had been completed prior to the accident at Walkergate.

Electrical protection of the train

- 23 Traction power is fed from the pantographs via a cable to a line breaker box (one on each car) containing three line breakers identified as LB1 to LB3⁴ (figure 6). The line breaker box is mounted below the floor of the car, directly under the pantograph (figure 3).
- 24 The function of line breakers is to control the power supply to the traction circuit of the car. The electrical contacts of the line breakers are only closed when the train is drawing traction power (figures 6 and 7). When the train is standing in a station, for example, the line breakers' contacts are open. However, LB1 remains live on the pantograph side of its open contacts.

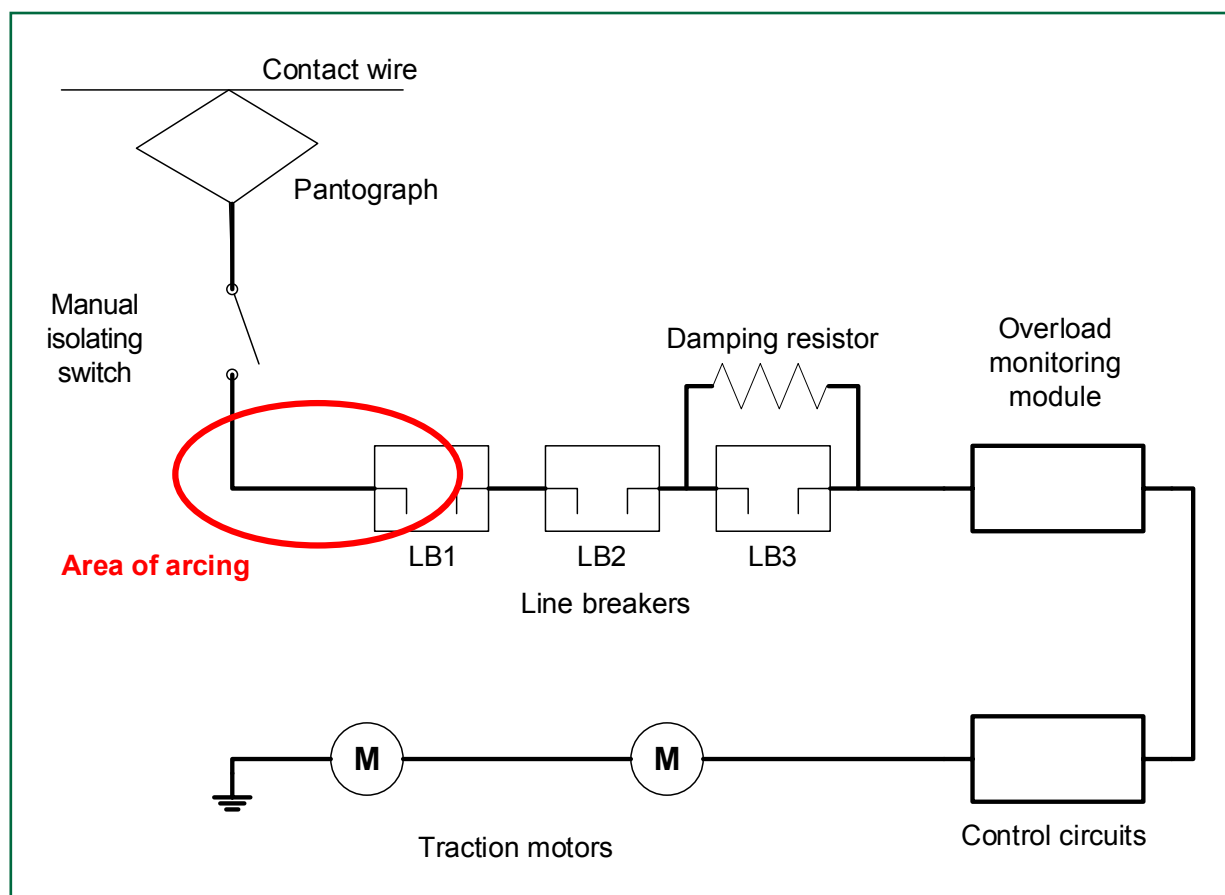

Figure 6: Metro car traction power circuit

⁴ There are three line breakers arranged in series. When commanded to open, LB3 opens first and puts a damping resistance into the circuit. LB1 and LB2 then open, disconnecting power to the downstream equipment. This arrangement is designed to limit and share the voltages that are developed across the line breakers when the contacts open.

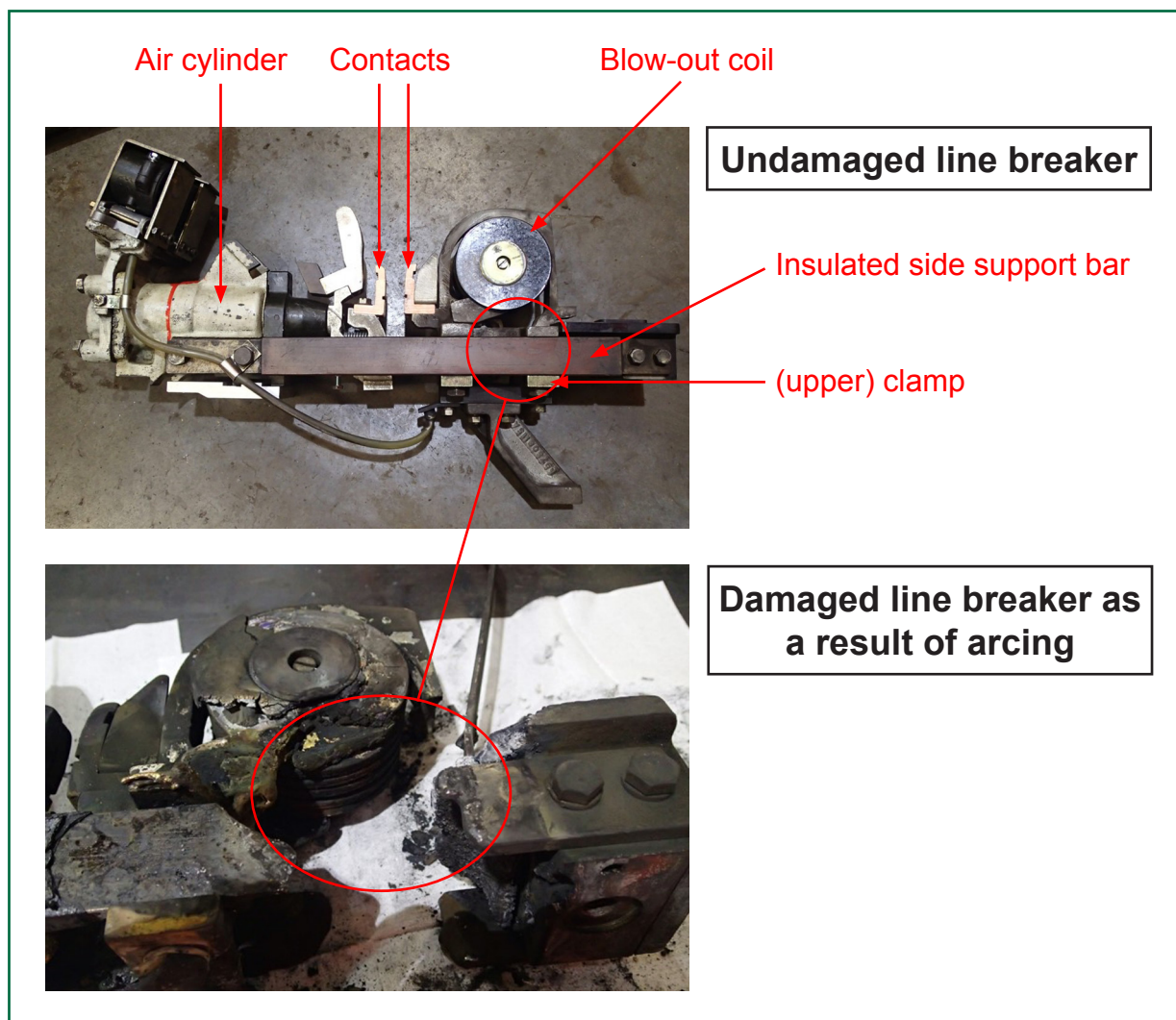

Figure 7: Undamaged and damaged line breakers

- 25 When the contacts of a line breaker are opened, an arc is created between its contacts. This is normal. The arc sustains the flow of current between the open contacts and so, to fully interrupt the current, it is necessary to extinguish the arc. To do this, the arc is deflected along a controlled and lengthening path by means of a magnetic 'blow-out' coil and is dissipated by a blast of compressed air from the exhaust of the cylinder that holds the contacts together (figure 7).
- 26 On-train equipment 'downstream' of the line breakers is protected by an overload monitoring module which automatically opens the contacts of the line breakers if the module detects a fault in traction equipment (figure 6). However, the line breakers themselves are not electrically protected by equipment on the train and rely on protection systems on the DC traction power supply.

Staff involved

- 27 The driver of train 130 had four years' experience since qualifying as a Metro driver. The driver was subject to routine assessments of his route knowledge and driving ability and received regular refresher training from DBTW. He was assessed by DBTW as fully competent.

- 28 The driver estimated that he experienced a loss of traction power about three or four times a year and was familiar with the procedures to be followed in these events.
- 29 The power controller on duty at the time of the accident had over 20 years' experience as a controller. He was subject to a programme of continuous assessment by DBTW, however, his competence to carry out the switching duties of a power controller was assessed by Nexus, on DBTW's behalf, every three years. The power controller was very experienced in using the computerised power control equipment, known as the 'supervisory control and data acquisition (SCADA) system', and in resetting circuit breakers after they had tripped the traction power supply to the overhead line.
- 30 The power controller was located in the DBTW control room at South Gosforth with other Metro staff including *system controllers* and *customer service controllers*.
- 31 The power controller was completing the third of a run of day shifts when the accident occurred. He had been on shift since 07:00 hrs and was due to be relieved, very shortly after the accident, at 19:00 hrs. His actions were consistent with normal control room practice and there was no indication that he was affected by fatigue.
- 32 A second power controller, who was due to relieve his colleague, was in the control room ready to carry out a shift handover.

External circumstances

- 33 The weather on the day of the accident was fine but windy. The accident occurred in daylight and there was good visibility.

The investigation

Sources of evidence

34 The following sources of evidence were used:

- witness statements;
- staff training records;
- CCTV recordings;
- recordings of voice communications;
- SCADA records;
- train maintenance records;
- electrical infrastructure drawings, schematics and records;
- Nexus High and Low Voltage rules and operating procedures;
- Nexus and DBTW risk assessment documentation;
- reports of previous accidents involving line breakers;
- Office of Rail and Road (ORR) records, including Nexus and DBTW applications to the ORR for authorisation/certification under the Railways and other Guided Transport systems (Safety) Regulations 2006; and
- a review of previous RAIB investigations that had relevance to this accident.

Scope of the investigation

35 The scope of the investigation did not include the cause of the initiating electrical fault affecting the train line breaker because:

- the RAIB has already made a recommendation to Nexus and DBTW (paragraph 116) regarding the identification of line breaker failure mechanisms and work to identify and manage possible failure mechanisms was on-going; and
- following the accident on 11 August 2014, the ORR commissioned an analysis of the line breaker involved to try to ascertain the cause of the fault (paragraph 63).

Key facts and analysis

Sequence of events

Events preceding the accident

- 36 The driver booked on duty at about 16:30 hrs and took over the driving of train 130 from South Gosforth. He drove the train to South Shields and was on the return journey to St James. He was not aware of any faults on the train and the journey was uneventful.
- 37 The train arrived at Walkergate station at around 18:56 hrs. The driver released the doors and two passengers got out of the leading car and left the station. The driver then closed the doors for departure. Meanwhile a train arrived in the opposite platform at the station.
- 38 Seconds later, a CCTV recording shows a momentary flash from the non-platform side of car 4090 (right-hand side in the direction of travel) followed by puffs of smoke rising from the area of the line breaker box. The internal lights on the train went out almost immediately after the flash. Passengers in both cars were alerted, probably by a noise, and some in car 4090 saw the smoke. They did not appear to be unduly alarmed and generally remained in their seats.
- 39 At the same time, SCADA records indicate that the circuit breaker at Byker substation tripped the power supply to the outbound line as a result of detecting an overload and sent an inter-trip signal which opened the circuit breaker at Percy Main. The driver reported that a display on his desk changed state, indicating that there was no power supply to the train from the overhead line (ie the circuit breakers at Byker and Percy Main were open). No other faults were displayed. He stepped out of his cab onto the platform to observe the overhead line and the train's pantographs which appeared to him to be in good order. He stated that he did not see or smell smoke at this stage, probably because it was approximately 40 metres from the cab on the other side of the train, and CCTV shows that it was dissipated by the train departing the opposite platform (paragraph 37).
- 40 When the circuit breakers at Byker and Percy Main substations tripped, alarms were sent to the power control desk in South Gosforth control centre. The power controller called over to the system controller (who controls the train service) in the same room to advise that the electrical power to the outbound overhead line had been lost in the Percy Main to Byker electrical section. The system controller ascertained from information displayed by the signalling system that train 130 was the only train in that electrical section and, in discussion with the power controller, a decision was made to contact the driver for a report.

- 41 The driver received a call on the radio from the system controller while he was on the platform close to the cab observing the overhead line. The call was recorded. The system controller informed the driver that the overhead line had tripped and asked the driver if there were any faults to report. The driver responded that he was looking at the pantographs and overhead wire, that he could not find any faults and that he would walk back along the train to check. The system controller asked the driver to report back when he had completed his check and, in compliance with procedures, the driver confirmed that he had understood the instruction. The driver reported that he was under the impression that power would not be restored until he had reported back on his inspection.
- 42 According to witness evidence the system controller relayed the driver's initial report of no faults to the power controller. The power controller then closed the circuit breaker at Percy Main substation which restored power at the end of the section furthest from the train (paragraph 66).

Events during the accident

- 43 Almost immediately, CCTV images show a large volume of smoke being given off around the line breaker box on car 4090, followed by flames (figure 8a).
- 44 The driver, who was recorded on CCTV walking back along the platform carrying out his check, had got about halfway along the leading car when he reported that he saw smoke, which he believed to be coming from the rear cab. He turned and hurried back towards the leading cab with the intention of releasing the doors so that passengers could escape from the train.
- 45 Before he got to the cab a large flash occurred on the contact wire in the area of the trailing pantograph and the contact wire parted. CCTV footage shows the loose ends of the contact wire whipping around the roofs of both cars, causing arcing and cascading sparks (figure 8b). (The contact wire also parted in two other places; around both pantographs and at a mid-point between them.) After about seven seconds one end of the live contact wire fell on to the platform (figure 8c). The electrical protection did not disconnect the power supply and the wire on the platform remained live.
- 46 Passengers in both cars, but particularly in car 4090, were observed on CCTV to become alarmed. They quickly started moving towards the doors and began pressing door buttons to leave the train. The doors, however, remained closed.
- 47 Meanwhile, the relief power controller, who was in the control room for a shift handover, selected CCTV images from Walkergate station to observe train 130. He saw the smoke and arcing from the flailing contact wire and called to the power controller to turn off the power.
- 48 The power controller immediately opened Percy Main substation circuit breaker to disconnect the traction power supply to the train. Once the power was removed, the smoke from the line breaker box quickly subsided and the de-energised contact wire came to rest on the platform adjacent to the rear-most set of doors, shown in figure 8c.



Figure 8: Sequence of events during accident (images courtesy of DB Regio Tyne & Wear Ltd)

Events following the accident

- 49 Passengers in car 4090 operated the door emergency release levers at two sets of doors, which allowed single door leaves to be opened, and began leaving the car about 18 seconds after traction power was switched off. Two passengers leaving through the rear-most doors were seen on CCTV to step on or near the de-energised contact wire.
- 50 Passengers in car 4010 appeared unable to open the doors using the emergency door release levers and the driver reported that some were banging on the windows. Passengers left the car when a set of doors was opened normally (ie both door leaves opened), about 30 seconds after power was disconnected, when the driver apparently released the doors⁵. Passengers then quickly cleared the platform and assembled outside the station.
- 51 The fire brigade was logged as being called by the Metro control room at 18:58 hrs and attended at 19:04 hrs, by which time the fire was no longer burning.
- 52 The contact wire was repaired overnight and the train was fit to be driven to the depot at South Gosforth, using car 4010 to haul car 4090.

Identification of the immediate cause

53 A sustained fault current drawn through the pantograph caused localised overheating and weakening of the contact wire, which then parted under tension.

- 54 When power was restored after being tripped by the initial fault (paragraphs 38 to 39), a fault in the line breaker box of car 4090 was re-established and severe arcing developed. The resultant fault current would have been passing through a relatively small area of contact between the overhead wire and the stationary pantograph causing localised heating.
- 55 When examined, there were globules of copper on the parted sections of the contact wire, indicating that it had melted. The contact wire is maintained at a uniform tension of 11 kN to prevent it sagging or over-tightening in extremes of weather. Extreme localised heating of the contact wire would cause a loss of mechanical strength in that area and the tension would tend to draw it apart. The parted faces of the wire had a characteristic 'necking', consistent with a failure under tension.
- 56 The contact wire parted about 18 seconds after the circuit breaker was reset which, from experience of the similar event at South Gosforth, is sufficient time to melt the contact wire. (The contact wire at South Gosforth parted about 12 seconds after a train with an electrical fault came to a stand.)

⁵ The doors are designed to be opened and closed when there is no power supply to the train from the overhead line.

57 Images from the station CCTV recordings and SCADA records indicate that both ends of the contact wire then remained live for a further 14 seconds until the power controller opened the circuit breaker at Percy Main substation. For the last seven seconds of this time the rear-most broken end was trailing on the platform (figure 8c). Although the current was only being fed from one end, the supporting catenary wire conducted current around the break in the parted contact wire so that both ends were live.

Identification of causal factors

58 A sustained overcurrent was drawn for the following reasons:

- electrical arcing occurred as a result of a fault in a part of the train's traction power circuit which is not protected by on-train equipment (paragraph 59); and
- the fault current drawn by the arcing fault did not exceed the overload settings of the circuit breaker at Percy Main substation or the mid-point line current relay (paragraph 64).

59 **Electrical arcing occurred as a result of a fault in a part of the train's traction power circuit which is not protected by on-train equipment.**

60 Line breakers are in a part of the power circuit of the train between the pantograph and the overload monitoring module which is unprotected by equipment on the train (paragraphs 23 to 26). For this reason sustained electrical faults in the line breaker box can only be interrupted by equipment in the external DC traction power supply.

61 The arcing which affected LB1 appeared to have occurred in the vicinity of the blow-out coil and the insulated side supports (figure 7). The damage was similar to, but not as extensive, as occurred in the previous accident at South Gosforth.

62 The accident at Walkergate was the eighth involving faults on LB1s since 1994, six of which have occurred since 2008. Five of the eight events have occurred in the Byker to Percy Main electrical section. In two previous events, (Monkseaton 2010 and South Gosforth 2013) the sustained fault current drawn was also sufficient to part the contact wire.

63 The damage to LB1 has, in all cases, destroyed evidence of the initiating event. After the accident at Walkergate the ORR took possession of the failed LB1 and another similar line breaker and arranged for an examination and report from the Health and Safety Laboratory (HSL). HSL was unable to reach a firm conclusion on the root cause of line breaker failures but considered that an insulation failure on a line breaker side support (figure 7) would be consistent with the evidence. However, because five of the eight line breaker events have occurred in the Percy Main to Byker electrical section, the report draws a link to the possibility of an unknown external factor.

64 The current drawn by the arcing fault did not exceed the overload settings of the circuit breaker at Percy Main substation or the mid-point line current relay.

65 When power to the overhead line was restored arcing from a fault on LB1 was re-established but the fault current drawn did not trip the circuit breaker. This was because:

- the power controller closed the circuit breaker at Percy Main supplying power to the electrical section from a single end, 5,591 metres away from the train;
- the electrical resistance over this long distance limited the fault current to less than 2400 A (ie the overload setting of the Percy Main circuit breaker) and to less than 1500 A, (ie the overload setting of the line current relay); and
- in these circumstances, the only DC traction power supply protection equipment which could have detected the likely level of fault current being drawn was set to operate on a timer after the fault had been present for 70 seconds.

These factors are now considered in turn.

Re-closure of circuit breaker at Percy Main

66 The Nexus procedure used by DBTW power controllers for resetting circuit breakers after a DC traction power supply trip on overload, did not specify or provide guidance on which end of an electrical section to re-energise first. Witness evidence is that power controllers were not trained or instructed on which end to close first and that the decision was left to their discretion. The procedure did not require contact to be made with drivers before attempting to reclose the circuit breakers a first time. This procedure was reinforced in an email from Nexus sent to DBTW's power controllers after the accident at South Gosforth reminding power controllers that, unless advised of a problem, they may close a circuit breaker after an overhead line trip. When the power supply tripped at Walkergate there was only one train in the electrical section and, in these circumstances, it was a practice in the control room to contact the driver as it would save a further trip if the driver was able to identify a fault on the train.

67 The power controller's stated rationale for resetting the circuit breaker at Percy Main substation was that it had a lower overload setting than the circuit breaker at Byker substation (2400 A as opposed to 3000 A) and, if the fault remained, the circuit breaker would trip at a lower level of fault current. However, the overload protection at Percy Main had not detected the initial fault; it was only detected at Byker which inter-tripped the Percy Main circuit breaker. The Percy Main circuit breaker was therefore less likely to detect the renewed fault current once it was reset (paragraph 70). Had the circuit breaker at Byker been closed the fault would almost certainly have been detected once again.

- 68 After closing the Percy Main circuit breaker the power controller did not then immediately reset the circuit breaker at Byker. This was because he had developed the practice of re-closing one circuit breaker and waiting to see if it tripped before re-closing the other end. He reported that, in his experience, regardless of which end of the electrical section was reclosed, a circuit breaker had always tripped again if the fault remained. Other power controllers reportedly reset the circuit breaker at one end and waited for the timed overcurrent trip to time out before resetting the circuit breaker at the other end. This was to ensure that if a fault drawing a low level of current persisted, it would be detected by the timed overload protection (paragraph 20) before double-end feeding was re-established.
- 69 A further consequence of not closing the circuit breaker at Byker was that the inter-tripping protection it provided to Percy Main substation was rendered inoperable.

Distance between Walkergate and Percy Main substation

- 70 The current supplied by Percy Main substation to the electrical arcing fault did not exceed the overload setting of its circuit breaker because it was limited by electrical resistance over the distance between Percy Main and the train (paragraph 19).
- 71 The value of the fault current was not recorded by the Nexus SCADA system but calculations by Nexus indicate that the maximum fault current supplied from Percy Main (assuming the fault was making a zero resistance short circuit) would have been 1725 A and not enough to immediately trip the circuit breaker. However, the maximum value of a fault current if supplied from Byker substation was calculated to be 6429 A, which would exceed its overload setting.
- 72 In this accident, the fault current supplied from Percy Main substation would have been considerably less than 1725 A. This is because it was feeding an arcing fault which does not act as a zero resistance short circuit (ie it behaves as a restricted short circuit (paragraph 20)). The RAIB estimates that the level of fault current was probably in the order of 1000 A, which would have been undetectable by the 1500 A line current relay.

Timed overcurrent protection

- 73 The timed overcurrent trip is set to open the circuit breakers at both Byker and Percy Main if a current of more than 800 A is drawn continuously for 70 seconds (paragraph 20). The operation of the timer is not recorded but if working correctly, the timer should have started for the estimated level of fault current (paragraph 72). However, the timed overcurrent protection would only operate if a fault current of at least 800 A was maintained for 70 seconds. It is likely that, once the contact wire parted, the fault current would have fluctuated as the loose contact wire made and lost contact with the train roof. If the fault current fell below 800 A at any time, the timer would reset to zero. The timed overcurrent trip may not, therefore, have disconnected the power after 70 seconds and the event could have continued until, for example, the driver made an emergency call to report what was happening.
- 74 In this case, the timed overcurrent trip did not operate because the power controller opened the circuit breaker at Percy Main substation to switch off the current after 28 seconds.

Identification of underlying factors

Risk management

75 Nexus, working with DBTW, did not effectively manage the system interface risk between the DC traction power supply, power control and the train.

76 The accident occurred at the interface between three system components: the DC traction power supply (Nexus), power control (DBTW and Nexus) and the train (DBTW and Nexus), with each contributing to the outcome. The investigation found that risks from each element within the system had been assessed. However, there was little evidence that the risks created at the interfaces between them had been identified, assessed and managed in a co-ordinated way.

Identification and assessment of interface risks

77 In its report into the South Gosforth accident, the RAIB concluded that Nexus and DBTW did not fully understand the risks associated with train line breaker failures. The RAIB recommended that Nexus, with support from DBTW, should lead a detailed assessment of the risks associated with the line breaker unit, taking account of the configuration and reliability of the electrical protection systems currently provided on the Metro system.

78 The investigation found that, although Nexus and DBTW had worked together in undertaking a series of assessments, the risks concerning both Nexus and DBTW associated with line breaker failures were not fully identified. Three separate risk assessments were completed:

- overhead line reset procedure (DBTW with Nexus support) dated September 2013;
- line breaker failure modes (Nexus with DBTW support) dated February 2014; and
- evaluation of the DC traction (power supply) protection (Nexus) dated June 2014.

79 The assessments collectively identified the factors that contributed to the accident at Walkergate, ie they recognised that, as a result of a recurrent problem on train line breakers:

- a sustained fault current could be drawn;
- the DC traction power supply protection may not operate quickly; and
- the contact wire could part and, in some circumstances, remain live.

However, the combination of circumstances which could give rise to this situation and the consequences were not analysed in a systematic way.

- 80 The Nexus-led risk assessments of line breaker failure modes and the DC traction power supply protection system were conducted using a simple 5 x 5 risk ranking matrix. The DBTW-led risk assessment of the overhead line reset procedure used a similar risk ranking method. These assessment techniques are generally more suited to workplace hazards than complex electrical systems. Such systems require a more analytical approach, such as fault tree analysis⁶, failure mode and effects analysis⁷, or a hazard and operability study⁸ for the identification and evaluation of interface risks.
- 81 A systematic analysis of the interfaces between the DC traction power supply protection system, power control and train line breakers could have identified the potential failure mechanisms that led to the accident at Walkergate. For example, the upgraded inter-tripping system (paragraph 22) was cited as a mitigation to protect trains against line breaker faults and for protecting the DC traction power supply against restricted short circuits (paragraph 20). A thorough analysis of the possible failure modes of the inter-tripping system might have found that the protection it provided could be negated by the actions of a power controller and led to technical control measures to prevent this from happening. In the short term, additional mitigation could have been implemented at minimal cost (such as the enhancement of control room procedures and training).
- 82 The risk assessment technique used by Nexus for assessing the DC traction power supply protection and by Nexus and DBTW for assessing the line breaker failure modes did not include the use of cost benefit analysis for determining whether the risk had been reduced as low as reasonably practicable. Cost benefit analysis gives monetary values to costs and benefits, enabling a comparison of like quantities. A safety measure is regarded as reasonably practicable unless there is a gross disproportion in the ratio of costs to benefits.
- 83 The DC traction power supply protection risk assessment identified the possibility of installing a type of protective relay (known as a 'multi-function' relay) in the DC traction power supply which better discriminates between fault currents and normal start-up currents drawn by trains, and which operates quickly to protect against faults. Nexus concluded, however, that it was not reasonably practicable to fit multi-function relays to the existing system but these would be included in the planned upgrades to the DC traction power supply system from 2021. This conclusion was reached on the basis of qualitative, rather than a quantitative, evaluation of the cost and safety benefits.
- 84 The risk assessment process used by Nexus' engineers to assess the DC traction power supply protection and to evaluate whether the risks identified had been reduced as low as reasonably practicable, was not challenged by Nexus safety department.

⁶ Fault tree analysis is a logical representation of a sequence of events leading to a single undesired event. It is used to understand how systems can fail and to calculate the probability or frequency of the event occurring.

⁷ Failure mode and effects analysis (FMEA) is a technique for analysing and evaluating a system or part of a system, to identify how and where it might fail. It can be extended to include a criticality analysis (FMECA) to chart the probability of failure modes against the severity of consequences.

⁸ A hazard and operability study (HAZOP) is a structured examination of a process or operation using guide words to prompt participants to identify safety and operational issues associated with design, operation and maintenance.

- 85 The RAIB notes that in its application to the ORR for a safety certificate and safety authorisation⁹ in 2011, Nexus stated a commitment to the use of structured risk assessment techniques incorporating quantified risk assessment methodology for ensuring that its risks were as low as reasonably practicable¹⁰. The RAIB also notes that while Nexus had the competence within its safety department to carry out complex risk assessments (which it used, for example, to assess level crossing risks), it did not always draw on it. Similarly, DBTW had a process incorporating quantified risk assessment which it used for assessing risks at the train/platform interface, but did not always apply this technique where appropriate.

Management of interface risks

- 86 Prior to the accident at South Gosforth, Nexus had not risk assessed the DC traction power supply protection system since it was commissioned in 1980. The RAIB was told that this was because the system had remained largely unchanged. However, the limitations of the DC traction power supply protection system to mitigate the effects of faults in the train power supply circuit between the pantograph and the overload monitoring module (paragraphs 23 to 26) became increasingly apparent when faults causing severe arcing and fires on line breaker boxes started around 1994. Internal investigation reports into the early line breaker accidents (Walkergate 1994 and Chillingham Road 1999) commented on the delay in the operation of the DC protection system, which allowed a sustained fault current to be drawn. The investigation report into the 1999 accident recommended a review of the DC traction power supply protection system. According to witness evidence, the review was carried out and concluded that the DC traction power supply protection had operated as designed, which was without consideration for the protection of trains, and no further action was taken.
- 87 At Monkseaton in 2010 a fault in a train line breaker box led to the parting of the contact wire. It seems that the DC traction power supply tripped around the time that the contact wire parted and there was no further damage. The investigation into the failed contact wire carried out by Nexus identified that the level of current drawn by the line breaker fault on the train caused localised heating leading to a loss of tensile strength and failure of the contact wire under tension. The report concluded that the underlying cause was a train equipment fault, which should be investigated by DBTW. This event, a precursor to the accidents at South Gosforth (2013) and Walkergate (2014), did not prompt a review by Nexus of the inability of the DC traction power supply protection to prevent a sustained fault current from melting the contact wire.
- 88 Witnesses reported a perception that the recurring incidents with line breakers were regarded by Nexus as a 'train problem' which the 'train people', initially at Nexus and later at DBTW, should fix. The investigation of previous line breaker incidents was conducted by train fleet personnel without the involvement of power supplies expertise and may have led to this perception.

⁹ Nexus is required by the Railway and Other Guided Transport Systems (Safety) Regulations 2006 to apply to the Office of Rail Regulation (now the Office of Rail and Road) for a safety certificate and authorisation every five years. The application must describe its safety management system and how it ensures that it runs its transport system safely.

¹⁰ Nexus stated that it used 'Guidance on the preparation and use of company risk assessment profiles for transport operators' published by RSSB (<http://www.rssb.co.uk/Library/risk-analysis-and-safety-reporting/2009-guidance-guidance-on-preparation-and-use-of-company-rsk-assessment-profiles-for-transport-operators.pdf>).

- 89 It is probable that, had Nexus (and from 2010, Nexus working together with DBTW), ensured that the investigation of past train line breaker incidents included a thorough analysis of the response of the DC power protection system, the system-wide implications of the recurring problem associated with line breakers would have been recognised and the initiative taken for putting suitable mitigations in place earlier to control the consequences.

Factors affecting the severity of consequences

- 90 The event could have had more serious consequences if there had been passengers on the platform when the contact wire parted or if the driver had been in the path of the flailing live contact wire when he was returning to the cab.
- 91 It was fortunate that the driver had closed the doors for departure, which delayed the self-evacuation of passengers until after the contact wire had been de-energised.
- 92 The event could have lasted longer if the second power controller had not happened to be present and switched on CCTV images from Walkergate station.

Observations

Co-operation between Nexus and DBTW

93 The formal arrangements in place between Nexus and DBTW did not effectively facilitate the sharing of relevant safety information on matters relating to both organisations.

- 94 Witnesses told the RAIB that the 'Concession Office', which was established at Nexus to manage contractual communications between DBTW and Nexus, was quickly found to be a block to the timely exchange of health and safety information and effective decision-making. Informal communication channels emerged as a work-around for Nexus and DBTW staff which worked well because the relevant staff were former colleagues. However, on a formal level, relations were stated to be highly contractual and challenging at times. Senior managers at Nexus and DBTW told the RAIB that this could be explained, in part, by the parties' lack of experience of working under a contractual agreement and the need to resolve a number of commercial issues.
- 95 However, senior managers at Nexus and DBTW do not accept that there has been any problem with the free flow of health and safety advice or information. They have pointed to an extensive structure of meetings between the two organisations at which joint health and safety matters were resolved including, where necessary, some involving sizeable funding without reference to the commercial framework. They also consider that formal relations between the two organisations had matured and improved with time.

- 96 In contrast, there was some evidence that staff at DBTW perceived Nexus to be reluctant to share information openly. Witnesses from DBTW told the RAIB, for example, that it was difficult to obtain information from Nexus for accident investigations, that DBTW was not always told about relevant changes made by Nexus to the infrastructure and that Nexus could be slow to provide answers to queries on matters affecting health and safety. Furthermore, the ORR has provided evidence to the RAIB that they had concerns about the level of co-operation between Nexus and DBTW during the investigation of an accident in 2012 and that these concerns were discussed with both parties.

Power Control

97 The competence management of the power control function was split between DBTW and Nexus, and lacked formal structure.

- 98 The management of the power control function had remained largely unchanged since the start of the Tyne and Wear Metro system. The operating procedures (which remained under Nexus control) were written by consultants in 1980 and witness evidence is that they had not been formally reviewed since. Over time, power controllers had developed informal ways of working for tasks not covered by procedures, without these being risk assessed by Nexus to understand the potential safety implications. There had been no new power controllers recruited since the start of Metro operations and Nexus had not developed or maintained a comprehensive training manual.
- 99 The transfer of the power control function from Nexus to DBTW in 2010 was reported to have caused divided loyalties among power controllers. At the time of the accident in 2014, DBTW was the employer of the power controllers and was responsible for their competence management. However, the assessment of their competence and authorisation to carry out power control switching duties remained with Nexus (under a non-contractual agreement) because it was considered that DBTW did not have the expertise to provide it. Power controllers therefore looked to Nexus for professional leadership.
- 100 Although DBTW had no concerns about the competence of power controllers, a DBTW manager stated that the way that power controllers' competence was assessed by Nexus was not to the standard DBTW applied to other front-line staff.

DC traction power supply protection system

101 The regime for the assurance of DC traction power supply protection settings was incomplete.

- 102 An inspection and testing regime to validate the overload settings of substation circuit breakers was established after the accident at South Gosforth. This provided assurance that the circuit breakers were, in the main, operating at their designated settings. It is planned that they will in future be tested every five years. Periodic testing has also been introduced for the timed overcurrent trip and inter-tripping equipment.
- 103 However, a similar regime is not in place for line current relays to test that they operate at their set current. These cannot be tested in situ because of the unavailability of local power supplies. Line current relays are exposed to the weather and, having moving parts, were identified in the DC traction power supply protection risk assessment as vulnerable to failure.

104 Although there is no evidence that the line current relay in the Percy Main to Byker section was not working at the time of the accident, or that the level of fault current should have been detected by the line current relay, Nexus was unable to confirm it was fully functional and fault-free at the time of the accident.

The role of the Office of Rail and Road (ORR)

- 105 In 2010 the ORR issued DBTW (as a train operator) with a safety certificate and in 2011 issued Nexus (as an infrastructure owner) with a safety authorisation, confirming the ORR's acceptance of their respective safety management systems (and in compliance with the Railways and Other Guided Transport Systems (Safety) Regulations 2006). Each organisation was then subject to a five-year inspection plan over the periodicity of the certificate/authorisation to confirm that their safety management systems were delivering appropriate levels of safety for workers and passengers. The responsibility for regulating Nexus and DBTW was, at that time, allocated to different ORR teams.
- 106 The ORR reported that it had adopted a 'light touch' approach to regulation of Nexus and DBTW. This was largely because, for many years, Nexus, and later, Nexus and DBTW, had given few causes for intervention, such as reportable accidents or serious complaints. The ORR had no records of any interventions relating to the DC traction power supply protection system.
- 107 The ORR told the RAIB that it only became aware of the history of arcing events on line breakers after the accident at South Gosforth in 2013.
- 108 In 2012, through its dealings with DBTW, the ORR became aware of problems related to co-operation between DBTW and Nexus. Its concern specifically related to the exchange of information for the investigation of an accident involving a train and the signalling system. Around this time the ORR took the decision to combine responsibility for both Nexus and DBTW in one ORR team so that it could address these interface issues more effectively. A combined five year inspection plan was prepared but this did not proceed as intended because resources were redirected to the ORR's investigation of the accident at South Gosforth in early 2013, and in July 2014, by the investigation of a fatal accident to a member of Nexus staff (this accident was outside the scope of the RAIB).
- 109 Since the accident at Walkergate in August 2014, the ORR has reported that it has engaged at senior levels with Nexus and DBTW to seek to improve co-operation on safety matters and to obtain assurances regarding early improvements to the DC traction power supply protection systems (paragraphs 125 and 126) and/or the fitting of fuse protection to trains (paragraph 129).

Summary of conclusions

Immediate cause

110 A sustained fault current drawn through the pantograph caused localised overheating and weakening of the contact wire, which then parted under tension (**paragraph 53**).

Causal factors

- 111 A sustained overcurrent was drawn because:
- a. electrical arcing occurred as a result of a fault in a part of the train's traction power circuit which is not protected by on-train equipment and which relies on the DC traction power system to detect it and to disconnect the current (**paragraph 59**, no recommendation); and
 - b. the current drawn by the arcing fault did not exceed the overload settings of the circuit breaker at Percy Main substation or the mid-point line current relay (**paragraph 64**, no recommendation).

Underlying factors

112 Nexus, working with DBTW, did not effectively manage the system interface risk between the DC traction power supply, power control and the train (**paragraph 75, Recommendation 2**).

Observations

- 113 Although not linked to the accident on 11 August 2014, the RAIB observes that:
- a. The formal arrangements in place between Nexus and DBTW did not effectively facilitate the sharing of relevant safety information on matters relating to both organisations (**paragraph 93, Recommendation 1**).
 - b. The competence management of the power control function was split between DBTW and Nexus, and lacked formal structure (**paragraph 97, Recommendation 3**).
 - c. The regime for the assurance of DC traction power supply protection settings was incomplete (**paragraph 101**, no recommendation).

Previous occurrences of a similar character and RAIB recommendations relevant to this investigation

Accident at South Gosforth on 8 January 2013, RAIB report 18/2013

- 114 A Metro train developed an electrical fault on a line breaker after departing South Gosforth station which tripped the circuit breakers on the traction power supply. While the train was coasting to a stop, it passed into the next electrical section and traction power was restored to the fault. A fire developed in the line breaker box and the overhead line parted ([RAIB report 18/2013](#)).
- 115 The RAIB's investigation of the accident at South Gosforth found the following similarities with the accident at Walkergate:
- power to the fault on the train was restored from the remote end of the electrical section;
 - the fault current was not detected from the remote end of the section; and
 - some passengers found it difficult to open the doors to evacuate the train.
- 116 RAIB report 18/2013 made two recommendations of relevance to the accident at Walkergate:

Recommendation 1

'Nexus, supported by DBTW, should carry out a detailed risk assessment of the risk associated with faults in the line breaker unit, which should include ... consideration of the possible effects of line breaker faults, taking account of the configuration and reliability of the electrical protection systems currently provided on the Metro system (and take) appropriate action to reduce the risk and potential consequences of failures ...'

Recommendation 2

'DBTW, supported by Nexus, should establish the maximum level of force required to enable a diverse range ... of passengers to easily operate the emergency door release handles on the Metro car fleet, and implement the necessary inspection and maintenance processes to achieve it in practice, taking account of the need to balance the ease of operation in emergency with the risk of undesired door releases.'

Status of actions taken to implement recommendation 1

- 117 In June 2014 the ORR advised the RAIB that Nexus and DBTW had prepared joint risk assessments and had drawn up a joint action plan to reduce the risks associated with line breaker fires and to enhance the DC traction power protection systems (paragraphs 77 to 84). The ORR had accepted the risk assessments as suitable and sufficient and advised that it would continue to engage with Nexus and DBTW to assure the planned actions were completed. These included a feasibility study on extending the installation of multi-function relays¹¹ (paragraph 83). The ORR indicated that a further update would be provided to the RAIB in December 2014. However, no update was provided. The RAIB understands that the ORR has deferred its further response to the RAIB on the implementation of recommendation 1 of the South Gosforth report, pending further actions taken by Nexus and DBTW in the light of the Walkergate accident.
- 118 At the time of the accident at Walkergate in August 2014, the feasibility study on the fitting of multi-function relays throughout the system (paragraph 117) had been completed and Nexus had decided that it was not reasonably practicable to fit them before the planned upgrades to the overhead power supply system due to commence in 2021.

Status of actions taken to implement Recommendation 2

- 119 In June 2014 the ORR advised the RAIB that, following a report by DBTW into the appropriate level of force needed to enable a range of passengers to easily operate the emergency door handles on Metro trains, a commitment had been made by DBTW to make reasonable adjustments to ease the operation of the doors in an emergency. The ORR expected the recommendation to be implemented by December 2014 but would update the RAIB on progress at that time.
- 120 At the time of the accident at Walkergate in August 2014, none of the doors on the train had undergone the planned adjustments although the signage for passengers on the operation of the emergency door release handles had been improved. An overhaul of the emergency door release mechanism on Metro trains is being carried out as part of an on-going upgrade to extend the life of the Metro fleet. In this instance, the apparent difficulty experienced by passengers in car 4010 in opening the doors did not compromise their safety (paragraphs 49 and 50).

Overhead line failure at St Pancras International on 23 September 2009, RAIB report 12/2010

- 121 An excessive current drawn between the overhead wire and a stationary train's pantograph caused the overhead wire to part and fall on the platform. The circuit breaker on the power supply tripped to de-energise the wire. Over the next two and a half minutes, there were three automatic attempts to close the circuit breaker and two manual attempts by the electrical (power) controller, with the loose overhead wire being briefly energised each time (RAIB report 12/2010).
- 122 While this occurrence has some similarities with the accident at Walkergate station in August 2014, the safety lessons are different.

¹¹ Nexus already has multi-function relays on part of its network. They were installed on the Bank Foot to Airport extension in 1991, on the extension to Sunderland in 2002, and at Gosforth depot in 2014 as part of an upgrade to the depot traction power supply. The feasibility study concerned the installation of multi-function relays on the rest of the Nexus network.

Actions reported as already taken or in progress relevant to this report

Actions reported that address factors which otherwise would have resulted in a RAIB recommendation

- 123 A review of the risk assessments, which were completed to implement recommendation 1 of the South Gosforth report (paragraph 116), is currently underway by Nexus and DBTW.
- 124 At the time of the accident, DBTW had already begun a process to bring the assessment of power controllers' competence in-house and to align the power controllers' assessment process with its existing competence management system. DBTW has reported that this process is now complete (paragraphs 97 to 100).
- 125 Nexus is reportedly in the process of replacing its mid-point line current relays with a modern digital type relay which is easier to maintain and test (paragraphs 101 to 104).

Other reported actions

- 126 Nexus reconsidered its decision to defer until 2021 the fitting of multi-function relays throughout their DC traction power supply system (paragraph 83). A feasibility study concluded that multi-function relays could be successfully incorporated with existing equipment and funding approval was given in June 2015 for their earlier installation across the Nexus network.
- 127 DBTW has introduced a requirement as part of the circuit breaker reset procedure for power controllers to look at CCTV images to observe any trains in stations.
- 128 DBTW has implemented a new operating procedure for drivers in situations where the train loses its DC traction power supply but the train's overload monitoring modules have not operated (paragraph 26). Before the controller resets the power supply, the driver is to inspect the train for evidence of smoke or smell from the line breaker boxes. If nothing is found, a report is to be made to the system controller and the power controllers can then reset the circuit breakers.
- 129 Nexus has taken advice on the fitting of fuses to trains on the supply (pantograph) side of the line breakers and preparatory work was on-going on procuring suitably rated fuses. However, Nexus has indicated that, though both the options of fitting fuses to trains and multi-function relays to the DC traction power supply protection system were being pursued in parallel, its preferred option was to fit multi-function relays and as this is now going ahead (paragraph 126), fuses may not ultimately be fitted.
- 130 Nexus has reported that discussions are underway to return the power control function from DBTW to Nexus. This follows a commitment by DBTW and Nexus in 2013 to a review of the reporting arrangements for power controllers and the transfer to Nexus is likely to take place in 2015.
- 131 DBTW has reported that it has recognised the need for more comprehensive risk assessment methodologies within its 2015 safety plan.

Recommendations

132 The following recommendations are made¹²:

- 1 *The intent of this recommendation is to achieve an improved safety management system at Nexus better capable of managing its shared risks.*

Nexus should review its safety management system to ensure that it provides an adequate framework for the management of its shared risks. Nexus should also review the effectiveness of current arrangements with DBTW with a view to reaching a more effective arrangement on the exchange of relevant safety information to facilitate the management of shared risks (paragraph 113a).

- 2 *The intent of this recommendation is for Nexus and DBTW to better understand the risks that are created at the interface between their respective operations.*

Nexus together with DBTW should identify (or review) and assess jointly created risks that occur at all interfaces between the infrastructure, power operations and trains. This should include the use of suitable risk assessment methodologies appropriate for identifying potential failure modes and their consequences, and a recognised technique for assessing the extent to which additional mitigations are required to reduce the risk as low as reasonably practicable. To this end, Nexus and DBTW should ensure that they have access to, and utilise, competent advice on conducting assessments of system-wide risks (paragraph 112).

- 3 *The intent of this recommendation is to achieve a comprehensive set of power control procedures to aid power controllers to make safe decisions.*

Nexus and DBTW should together complete the on-going review of procedures and practices followed by power controllers, with a view to providing a codified set of procedures, that have been appropriately risk assessed. Such procedures should be briefed out to power controllers and linked to the power controllers' training and competence management systems (paragraph 113b).

¹² Those identified in the recommendations, have a general and ongoing obligation to comply with health and safety legislation and need to take these recommendations into account in ensuring the safety of their employees and others.

Additionally, for the purposes of regulation 12(1) of the Railways (Accident Investigation and Reporting) Regulations 2005, these recommendations are addressed to the Office of Rail and Road to enable it to carry out its duties under regulation 12(2) to:

- (a) ensure that recommendations are duly considered and where appropriate acted upon; and
- (b) report back to RAIB details of any implementation measures, or the reasons why no implementation measures are being taken.

Copies of both the regulations and the accompanying guidance notes (paragraphs 200 to 203) can be found on RAIB's website www.gov.uk/raib.

Appendices

Appendix A - Glossary of abbreviations and acronyms

A	Amperes
CCTV	Closed circuit television
DBTW	DB Regio Tyne & Wear Ltd
DC	Direct current
HSL	Health and Safety Laboratory
ORR	Office of Rail and Road, (formerly the Office of Rail Regulation)
SCADA	Supervisory control and data acquisition

Appendix B - Glossary of terms

All definitions marked with an asterisk, thus (*), have been taken from Ellis's British Railway Engineering Encyclopaedia © Iain Ellis. www.iainellis.com.

Arcing	The flow of electricity through the air from one conductor to another. Arcing can produce visible flashes and flames.
Circuit breaker	An automatically operated switch designed to protect an electrical circuit from damage caused by overload or short circuit.
Customer service controllers	Staff based in the control room at South Gosforth, who respond to communications from station help points, and deal with matters such as fire alarms and station security.
Dropper	The vertical wire link between contact wire and catenary wires in an overhead line electrification system which maintains the contact wire at the correct height.*
Inter-tripping	A system designed to open the circuit breakers at a substation feeding a double-end fed section, immediately the circuit breakers at the substation at the far end of the section are tripped by a fault condition, by sending a signal automatically between the two substations.
Line breaker	The circuit breakers which protect the traction equipment of a Metro car. They can be operated automatically or by the train driver.
Overcurrent	A current which is higher than the continuous rating of an electrical circuit.
Overload	A current which is so high as to be potentially or actually damaging to an electrical circuit.
Pantograph	A device fitted to the roof of an electric train that contacts the overhead contact wire, allowing power to be supplied to the train.
Power controller	A person who controls the electric power supply to the trains and who is responsible for the switching and isolation of associated electrical equipment.
Relay	An electromechanical device that utilises an electromagnet to make and break related sets of electrical contacts. Therefore, one electrical signal can be used to determine the connection or disconnection of many other circuits.*
SCADA	A computer programme for gathering and monitoring data from remote locations to provide control of equipment.
Short circuit	A circuit of lower resistance than the planned circuit through which current tends to divert, and can result in excessive current flow and damage.

System controller

Based in the control centre at South Gosforth, the system controller regulates and monitors the service to maintain its smooth running or minimise the impact of any incidents or delays. The system controller has two-way radio contact with trains.

Appendix C - Effect of increasing resistance on the size of current

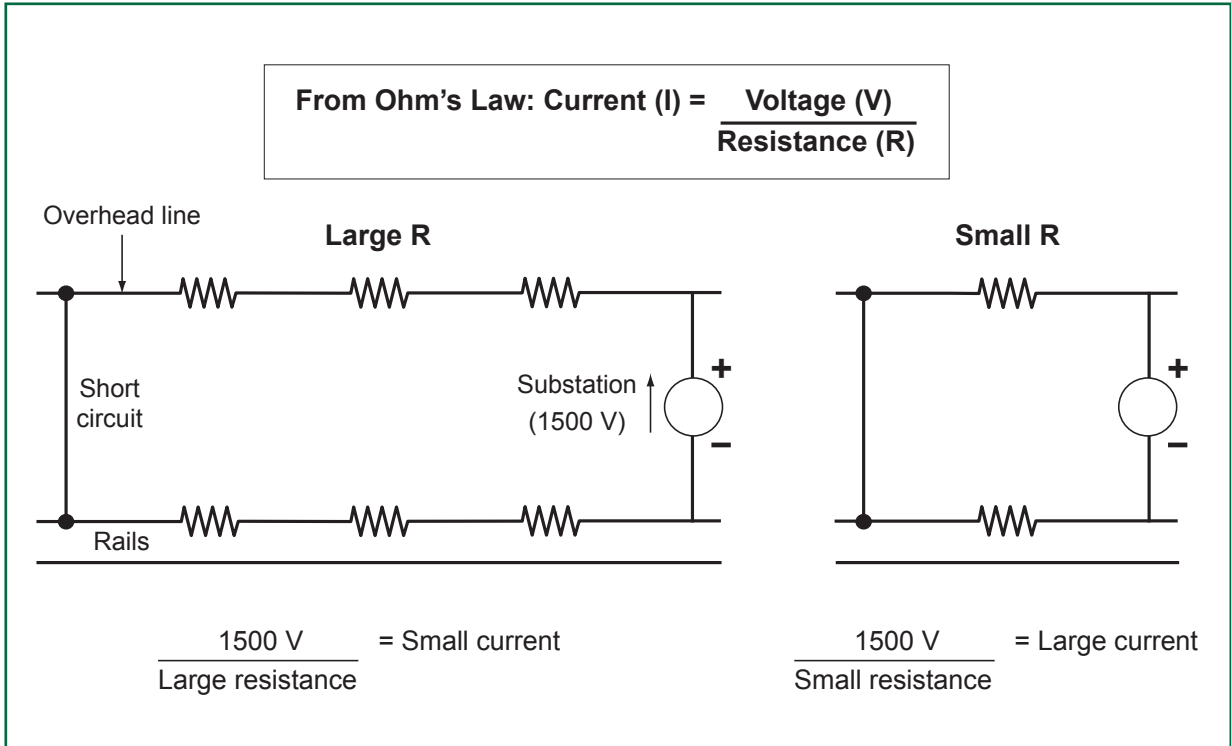

Figure C1: Simple illustration of the effect of increasing resistance on the size of current

This page is intentionally left blank

This report is published by the Rail Accident Investigation Branch,
Department for Transport.

© Crown copyright 2015

Any enquiries about this publication should be sent to:

RAIB	Telephone: 01332 253300
The Wharf	Fax: 01332 253301
Stores Road	Email: enquiries@raib.gov.uk
Derby UK	Website: www.gov.uk/raib
DE21 4BA	