

ARMY EQUIPMENT
SUPPORT PUBLICATION

2320-H-100-421
2nd Edition March 1990
(Superseding 1st edition
dated November 1986)

~~FOR OFFICIAL USE ONLY~~
~~CROWN COPYRIGHT RESERVED~~



TRUCK 4T, 4 x 4 BEDFORD MJP

CODE VB 2025 3100

SPECIAL ENVIRONMENT INSTRUCTIONS
WATERPROOFING INSTRUCTION NO.1

BY COMMAND OF THE DEFENCE COUNCIL

Sponsor: ATTURM
File ref:21/9/11

W. J. G. J. J.

Ministry of Defence

Publications
authority:ATTURM

Service users should send their comments through the appropriate channel as specified in AESP 0100-P-011-013.

CONDITIONS OF RELEASE

1. ~~This information is released by the UK Government for defence purposes only.~~
2. ~~This information must be accorded the same degree of security protection as that accorded thereto by the UK Government.~~
3. ~~This information may be disclosed only within the Defence Departments of the recipient government, except as otherwise authorised by Ministry of Defence (Army).~~
4. This information may be subject to privately owned rights.

AMENDMENT RECORD

Amdt	Incorporated by	Date
1		
2		
3		
4		
5		
6		
7		
8		
9		
10		
11		
12		
13		
14		
15		
16		
17		
18		
19		
20		
21		
22		
23		
24		
25		
26		
27		
28		
29		
30		
31		

Amdt	Incorporated by	Date
32		
33		
34		
35		
36		
37		
38		
39		
40		
41		
42		
43		
44		
45		
46		
47		
48		
49		
50		
51		
52		
53		
54		
55		
56		
57		
58		
59		
60		
61		
62		

CONTENTS

<u>Preliminary material</u>	<u>Page No</u>
Title page	(i)
Conditions of release	(ii)
Amendment record	(iii)/(iv)
Contents (this list)	(v)
Preface	(v)
Associated publications	(v)
MAN HOUR CONTENT	1
Introduction	1
Stores required	2
Stores to be demanded	2
General instructions	6
Materials, uses and application	6
Waterproofing arrangements	9
Checking the waterproofing kit	9
Waterproofing of cargo	9
Preparatory servicing	10
Fitting bung to bung clamp	11
Waterproofed equipment markings	12
Securing cable ties	13
WATERPROOFING STAGE A	14
WATERPROOFING STAGE B	103
DE-WATERPROOFING STAGE C	117
WET-SHOD RE-EMBARKATION	118
DE WATERPROOFING STAGE D	119
SUPERVISOR'S CHECK LIST	121
Table	
1 MAN HOUR CONTENT	1
2 COSA KIT CONTENT	2
3 SUPERVISOR'S CHECK LIST	121
Fig	
1 Prestikon application	7
2 Fitting bung to bung clamp	11
3 Waterproofed equipment markings	12
4 Securing cable ties	13

PREFACE

This publication and its associated instructions have been prepared in accordance with AESP 0100-P-005-010 and Joint Service Publications 181 to 188.

The Publication Authority for this series of Instructions is:

Amphibious Trials and Training Unit Royal Marines
Instow, Bideford
Devon EX39 4JH

Associated Publications
refer to AESP 2320-H-100-201 Operating Instructions
2320-H-100-522 Repair Instructions
2320-H-100-601 Maintenance Schedule

TABLE 1 - MAN HOUR CONTENT

Serial No	Detail	Approximate time in man-hours		Maximum No of men who can be usefully employed	Minimum time required hours
		Crew	Veh Mech		
1	Perusal of Introduction to the AESP and checking of Wpf Kit against Kit list.	2		2	1
2	Servicing of the equipment	5		2	3
3	Waterproofing Stage A	10.5	13	2	18
4	Waterproofing Stage B	3		2	2
5	De-waterproofing Stage C	0.25		1	0.25
6	Re-embarkation	0.75		1	0.75
7	De-waterproofing Stage D	8	2	2	6

INTRODUCTION

1. This instruction details the method of waterproofing to enable the vehicle to ford through an effective depth of 5 feet including ramp angle, wheel sinkage and wave height. The waterproofing when applied will enable the vehicle to ford with the minimum of preparation over a period of twelve months. To enable the vehicle to function either in its normal role or ford in water, the waterproofing kit is fitted in various stages.

STAGE A

The majority of the kit is fitted at this stage after which there are no limitations on vehicle usage. The date of fitting is to be recorded in the vehicle record book section 4.

STAGE B

The time taken to complete this stage is given in Table 1 Man Hour Content. This will permit the vehicle to disembark or embark wet-shod dependent upon operational requirements. On completion of this stage vehicle pre-ford mileage is restricted. Post ford mileage must conform to Stages C and D.

STAGE C

The tasks in this stage can be completed in a few minutes and must be carried out within 15 minutes after fording.

STAGE D

Tasks in this stage are dependent on operational conditions but vehicle servicing must be carried out with the minimum of delay.

Note ...

The kit has a twelve-month life after which it must be carefully examined by the Unit Waterproofing Adviser. Any suspect waterproofing aids will be replaced or in extreme cases, a complete new kit fitted.

2. Where variations from standard occur on the vehicle or equipment due to modifications or contract changes, advice and direction of a Waterproofing Adviser should be sought regarding additional or amended tasks.

Note ...

VEHICLE MECHANIC ASSISTANCE WILL BE REQUIRED FOR TASKS:

2, 3, 4, 5, 6, 11, 16, 18, 19, 20, 21, 22, 27, 28, 29, 30, 31, 32, 33, 34, 37, 38, 46, 49, 57, 84 and 85.

3. STORES REQUIRED

3.1 Waterproofing kits are M.O.D. controlled stores. Operationally they are issued without demand. Should issue be authorized for training purposes:-

3.1.1 In the U.K. they are to be demanded from the Ministry of Defence, DSM(A) Control Division, Bicester, through district headquarters.

3.1.2 Overseas, they are to be demanded through formation or district headquarters.

3.2 When a complete kit is required, the full Army designation of the vehicle or equipment, including code number and contract number is to be stated on the demand. Authority for issue must be quoted.

3.3 Normally, individual items and sub kits are not issued separately but may be demanded to make good kit deficiencies. Such demands are to quote full part numbers and designations as shown in this waterproofing instruction pages 3 to 5. A brief explanation of circumstances necessitating the demand is to be attached.

4. Stores to be Demanded

TABLE 2 - COSA KIT CONTENT

CAT No	Designation	Qty per veh
6WPG 2590 99 731 0612	Kit, waterproofing, truck 4 tonne MJP (WPG 9369) comprising:-	1
AESP 2320-H-100-421		
Wpf Instr No 1	2nd edition Mar 1990 Waterproofing instruction	1
6WPG 2540 99 815 9680	Container polythene (WPG 9085)	1 0
6WPG 2540 99 816 1916	Cover general purpose No 5 (WPG 7857)	4 *
6WPG 2540 99 816 2428	Band rubber (WPG 7779)	4 *
6WPG 2540 99 822 3031	Cover hydraulic fluid reservoir (WPG 9184)	4 *
6WPG 2540 99 822 7640	Cover hydraulic fluid reservoir No 2 (WPG 9239)	2 *
6WPG 2910 99 823 9601	Cover fuel tank filler (WPG 9185)	2 *
6WPG 2540 99 816 1896	Lead, extension (WPG 7788)	1
6WPG 2540 99 819 3427	Lead, extension (WPG 9178)	1
6WPG 2540 99 822 3033	Lead, extension (WPG 9191)	1
6WPG 2990 99 730 9549	Lead, extension (WPG 9372)	1 0
6WPG 2920 99 731 5176	Lead, extension (WPG 9376)	1
6WPG 2920 99 730 9550	Lead, extension ignition switch (WPG 9374)	1 0
6WPG 2540 99 819 1611	Adaptor slip ring housing (WPG 9176)	1
6WPG 2990 99 730 0610	Adaptor engine crankcase breather (WPG 9373)	1 0
6WPG 2540 99 838 9990	Adaptor brake relay valve (WPG 9358)	1 0
6WPG 2590 99 602 0950	Adaptor air cleaner (WPG 9403)	1 0
6WPG 4730 99 526 0422	Adaptor breather actuator No 4 (WPG 9395)	1 0
6WPG 4730 99 419 9080	Adaptor breather actuator No 5 (WPG 9396)	1 0
6WPG 4710 99 087 0514	Extension air pipe (WPG 9383)	1 0
6WPG 4710 99 852 8280	Extension pipe (WPG 9482)	1 0
6WPG 2540 99 819 3426	Bracket horn mounting (WPG 9177)	1 0
6WPG 2540 99 823 9608	Bracket tachometer (WPG 9226)	1 0
6WPG 2990 99 730 0609	Bracket trailer brake (WPG 9375)	1 0
6WPG 2540 99 817 9523	Valve non-return ¼ in. dia. (WPG 9138)	8 *
6WPG 2540 99 816 2506	Valve non-return ⅜ in. dia. (WPG 9123)	2 *
6WPG 2540 99 817 6915	Valve non-return ½ in. dia. (WPG 9137)	2 *
6WPG 2540 99 817 9527	Valve non-return 1 in. dia. (WPG 9157)	4 *
6WPG 2540 99 818 8177	Valve non-return 1¼ in. dia. (WPG 9173)	6 *
6WPG 2990 99 730 9552	Extension, air intake (WPG 9371)	1 0
6WPG 4720 99 731 0611	Hose non-metallic (WPG 9380)	1 0
6WPG 2990 99 730 9551	Box (cold start) (WPG 9370)	1 0
6WPG 5330 99 823 9609	Washer, oil filler cap (WPG 9227)	2 *
6WPG 2540 99 816 2664	Sealing compound prestikon (WPG 8120)	48 ft.
6WPG 2540 99 822 2576	Bung rubber (WPG 9179)	1
6WPG 2540 99 816 2670	Bag envelope P.V.C. (WPG 8220)	6 *
6WPG 2540 99 823 9603	Gaiter clutch lever (WPG 9221)	2 *
6MT1 4730 99 533 2961	Clamp hose 22 mm - 30 mm i.d.	3
6MT1 4730 99 533 2963	Clamp hose 27 mm - 40 mm i.d.	2
6MT1 4730 99 533 2972	Clamp hose 90 mm - 120 mm i.d.	4

TABLE 2 - COSA KIT CONTENT (continued)

CAT No	Designation	Qty per veh.
6MT1	5310 99 801 4802 Washer flat fibre 7/16 in. i.d.	4
H9	5310 99 943 4400 Washer flat fibre 5/8 in. i.d.	2 *
6MT1	5325 99 829 7075 Grommet blank rubber 3/8 in. groove dia.	2
6MT1	5325 99 818 7636 Grommet blank rubber 3/4 in. groove dia.	2 *
6MT1	5325 99 621 2514 Grommet blank rubber 1 in. groove dia.	2 *
H9	5325 99 942 6842 Grommet rubber 7/16 in. dia. hole	4 *
H9	5325 99 942 3430 Grommet rubber 1/2 in. dia. hole	8 *
H9	5325 99 942 6849 Grommet rubber 9/16 in. dia. hole	2 *
6MT4	5340 99 820 5371 Cable tie	30*
Z4	5340 99 634 3493 Cable tie	4 *
6MT4	5340 99 742 6346 Cable strap	10 *
G2	4710 99 964 9973 Tubing copper 5 mm o.d.	150 mm
G2	4710 99 964 9979 Tubing copper 8 mm o.d.	50 mm
G2	4710 99 964 9986 Tubing copper 16 mm o.d.	50 mm
6MT6	4720 99 805 7764 Tubing rubber 5/32 in. i.d.	4 metres
6MT6	4720 99 805 7839 Hose rubber 7/32 in. i.d.	6 metres
6MT6	4720 99 805 7774 Hose rubber 3/4 in. i.d.	40 mm.
6MT6	4720 99 805 7729 Hose rubber 1 in. i.d.	1 metre
6MT6	4720 99 805 7805 Hose rubber 4 in. i.d.	75 mm
G1	5305 99 135 8978 M6 screw x 16 mm long	6
G1	5305 99 941 0725 7/16 in. UNC screw x 3/4 in. long	4
G1	5310 99 122 8065 Washer flat steel 6 mm i.d.	16
G1	5310 99 122 5295 Nut plain M6	6
G1	5320 99 433 2289 Rivet aluminium 3/16 in. o.d.	2*
F1	8020 99 943 0418 Brush artists flat No 6	2
H1	5970 99 224 4975 Silicone grease 12 oz aerosol can	1 can
H1	6810 99 220 3331 Trichloroethane 1.1.1 (cleaning purposes)	1 quart
H1	8030 99 224 5433 Sealant industrial EC-750-C 150 ML tube	2 tubes
H1	8040 99 224 7306 Adhesive Bostik 1GA 186	1 tube
H2	4020 99 138 4829 Line polypropylene 1.2 mm dia.	10 metres
H4	4020 99 942 5038 Rope sisal 5/8 in. dia.	6 metres
H4	8105 99 135 6188 Bag plastic PVC 203 mm x 254 mm	6*
H4	8105 99 135 6190 Bag plastic PVC 255 mm x 457.2 mm	2*
W17	5340 99 201 9092 Clamp loop	1
Z42	5970 99 774 9196 Insulation tape 19 mm wide	2 rolls
9ASC	4730 99 815 6652 Plug screwed	1
POL	5970 99 942 4829 Compound Silicone XG 250 225g tube	2 tubes
POL	6850 99 224 5311 PX24 Corrosion preventative compound	1 litre
	N.I.V. Stage A waterproofed equipment marker	2*
	N.I.V. Stage B waterproofed equipment marker	2*

*A spare is provided to cater for defective or damaged goods.

TABLE 2 - COSA KIT CONTENT (continued)

CAT No	Designation	Qty per veh.
Ø	Items of the waterproofing kit marked thus Ø on the kit list are reclaimable items and must be returned irrespective of condition to RSSD COD Donnington when final deproofing has been completed. Any unused cover elastic and PVC bags which were included as spares should also be included in the returned stores.	

Stores to be obtained locally:-

-	Grease XG-279 or approved equivalent (according to theatre)	1.5 kg
-	Grease PX7	500 g

5. GENERAL INSTRUCTIONS

- 5.1 The instructions in this publication describe the action to be taken before and after fording, to protect the equipment against damage resulting from immersion in sea water.
- 5.2 Waterproofing is carried out in stages and each stage is to be completed in the sequence given in this instruction. The tasks within each stage are shown in the most suitable sequence, but this may be varied according to circumstances. Where a complete task coverage requires more than one page, the task should be read in its entirety before commencing a page by page progression.
- 5.3 CLEANLINESS IS THE FIRST ESSENTIAL OF SUCCESSFUL SEALING. When applying compounds, ensure that the hands are clean and free from grease and that all surfaces to which sealing compounds are to be applied are scrupulously clean. Mud, oil, grease or water will spoil adhesion.
- 5.4 REMEMBER THAT ALL WATERPROOFING MUST BE 100 PER CENT SUCCESSFUL. One carelessly treated component may cause failure at a critical moment, so take great care with every detail. Whenever waterproofing is being carried out during wet weather, suitable shelter should be arranged over the vehicle.
- 5.5 The vehicle load must be made secure to prevent any movement whilst the vehicle is ascending or descending the ramp on the ship.
- 5.6 If difficulties are encountered, the Unit Waterproofing Adviser should be consulted.

6. MATERIALS, USES AND APPLICATION

6.1 Trichloroethane 1.1.1 is used for the final cleaning of surfaces before applying any of the various waterproofing materials.

6.2 Prestikon

6.2.1 Is a plastic sealing compound which, when moulded to joints and apertures prevents water entry. It is also used in some cases to cover electrical components and connections to prevent failure of the electrical system.

6.2.2 It is supplied in a box (minor pack) containing six double strips 24 in. x 1.1/2 in. wide, in protective wrapping. Four boxes packed in a larger container are known as a major pack.

6.2.3 The application of Prestikon is shown in Fig 1(B) and (C). It must not be removed from its wrapping until actually required for application. When handling, the hands must be clean and free from grease. Remove the backing strip as shown in Fig 1(A). Where a considerable length is called for in a particular task, it is better to apply a series of short lengths, overlapping the strips as shown

Fig 1 (A) APPLICATION OF PRESTIKON

1. Lay the strip on a clean surface, tear open the outer polythene envelope wrapping at one end, and slide out the Prestikon strip.
2. Remove the unperforated back paper. INSPECT PRESTIKON Sections showing signs of dryness or cracks must be removed by cutting out suspected section of the strip.

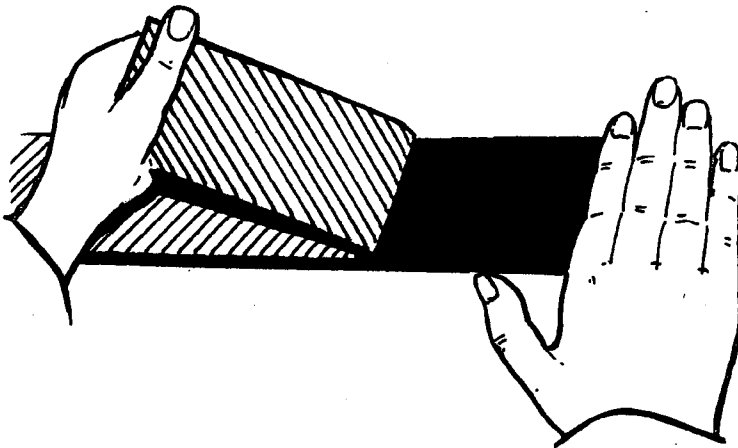

3. Strip the Prestikon down the middle along the perforated paper wrapper.

4. Cut off the required length.

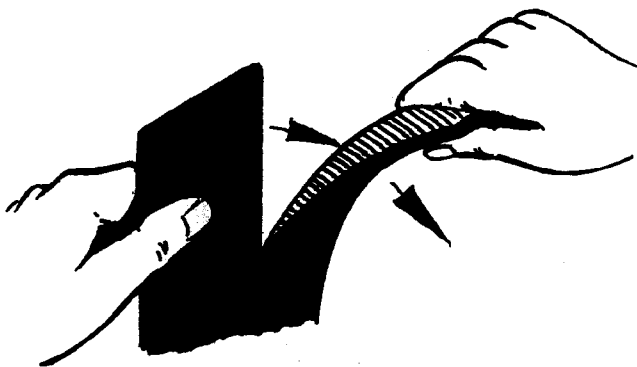

Note ...

Remove backing paper on the job.

Fig 1 (B) APPLYING PRESTIKON TO AN UNEVEN SURFACE

Using fingers, mould well down around uneven surface making sure no air pockets remain beneath the Prestikon.



Fig 1 (C) JOINING STRIPS OF PRESTIKON

Always overlap like this and, using fingers, lightly mould together.

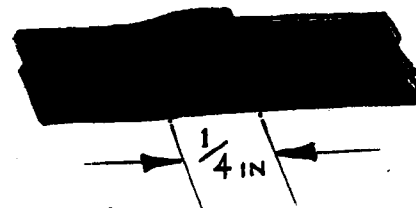

Fig 1 Application of Prestikon

in Fig 1(C), and moulding the top layer to the under layer. This allows ease of handling and avoids excessive stretch. It is important that strips of the correct length are used for each task as detailed in this instruction.

Note ...

Always keep Prestikon clean and dry. The biggest hindrances to successful waterproofing are oil, dirt, and water, therefore, all surfaces to be waterproofed must be perfectly clean and dry. The fingers may, however, be slightly moistened to prevent the Prestikon sticking to them.

6.3 Adhesive, Bostik 1GA 186: Obtainable in quart and half pint tins, this is a medium viscosity, buff coloured adhesive. It is easily applied by brush and adheres well to mild steel, painted steel, PVC, natural and neoprene rubbers, canvas and other surfaces.

6.4 Wading Fabric No 2: A two-ply waterproof fabric cemented with a rubber based adhesive. It is supplied in rolls 40 inches wide, the unit of issue being 1 yard. It is used for the manufacture of waterproof covers and bags for use in waterproofing kits. On occasions it is issued in small pieces in kits for covering holes too large for adhesive tape or Prestikon, or for repairing waterproof bags which have become damaged.

6.5 Covers, Elastic, Waterproofing: Manufactured from rubber and used to enclose various components. Before use, examine carefully and repair tears, splits or pin holes with adhesive tape. A spare cover of each type required to waterproof the equipment is provided in the kit.

6.6 Rubber Non-Return Valves: Are simple pressure activated valves made from thin rubber tube - they can be made from cycle or motor cycle inner tubes in an emergency. Their main use is to close up engine breathers when immersed, and to avoid excessive build up of crankcase pressure.

6.7 Grease: Is used for the protection against salt water corrosion on certain parts. The surface should be thoroughly covered with an even, unbroken film of grease. A lumpy coating is wasteful and provides no better protection.

6.8 Compound Silicone: Supplied in 250 g tubes and 12 oz aerosol containers for junction boxes, fuse holders and other electrical components which must remain operative at all times. The components should be covered with a generous, unbroken, even film of silicone compound.

6.9 Sealant, Industrial, 3M EC-750-C: Supplied in tubes or litre tins, industrial sealant EC-750-C is a joint sealant which dries to form a tough flexible seal, designed primarily to accommodate movement in ducting, other sheet metal fabrication and electrical cladding.

6.10 Fluid, Water Displacing, PX-24: Supplied in 1 litre containers in kits. It is used as an inhibitor for generators, starter motors and other electrical components during fording operations.

6.11 Solution, temporary protective, PX-10: Obtainable in 25 litre drums through RAOC channels. It is used as a flushing oil to decontaminate any assemblies which have been flooded by sea or fresh water.

6.12 Insulation tape: A waterproof adhesive tape, suitable for repairing and sealing PVC Bags, breathers, apertures, joints and components. The width of the tape can be increased by overlapping to the required width.

6.13 Bag, envelope PVC:

6.13.1 These bags are manufactured in varying sizes from a waterproof material, which are used to enclose parts of the vehicle as detailed in this instruction and other items as may be desired.

6.13.2 BEFORE USE, THE BAG MUST BE INSPECTED FOR PIN HOLES, TEARS OR SPLIT SEAMS, WHICH CAN BE REPAIRED WITH SUITABLE LENGTHS OF ADHESIVE TAPE, BOSTIK OR PRESTIKON.

WATERPROOFING ARRANGEMENTS

7. The operations are to be carried out by Unit personnel unless otherwise stated. THE WORK IS TO BE PLANNED AND CONTROLLED BY AN OFFICER WHO MUST ARRANGE FOR SUPERVISORS, TRAINED IN WATERPROOFING, TO INSPECT ALL TASKS PROGRESSIVELY TO ENSURE THAT THEY ARE COMPLETED SUCCESSFULLY. A check list to assist supervisors will be found at the end of this instruction. This list must be initialled by the supervisor as each task is passed as satisfactory.

CHECKING THE WATERPROOFING KIT

8. Before commencing waterproofing the equipment, the waterproofing kit must be checked against the kit list provided.

WATERPROOFING OF CARGO

9. Should it be desired to waterproof items of stores and equipment carried as cargo for which a waterproofing kit or specified suitable container is not available, use may be made of the range of BAGS, WATERPROOFING detailed below and available from RAOC Sources :

The following two PVC Bags are re-usable types fitted with zip closures, and primarily for use in 1/2 ton, 3/4 ton and 1 ton cargo trailers. The smaller one can also be used for waterproofing cargo in Land Rover cargo vehicles.

6WPG 2540 99 815 9470	72 in. x 36 in. x 18 in.
6WPG 2540 99 815 9471	36 in. x 36 in. x 18 in.

PREPARATORY SERVICING

10. Preparatory Servicing

10.1 Carry out 10000 Km (6000 mile) servicing (excluding oil changes) unless due within the next 1666 Km (1000 mile) as detailed in the servicing schedule to ensure full serviceability for fording.

10.2 Waterproofing demands maximum efficiency of vehicle performance. Ensure that your vehicle is 100 per cent fit for the task.

10.3 Headlamps, side and tail lamps, rear flasher lamps, rear fog guard lamps, trailer socket, convoy lamps are waterproofed in manufacture. Ensure that rubber seals are in place and undamaged. Where seals are suspect and spares are not available, seal as advised by the waterproofing Adviser/Supervisor, using the material provided. Before replacing the screwed lenses of side and tail, rear flasher, rear fog guard lamps when removed for the inspection of seal, smear threads with grease.

11. FITTING BUNG TO BUNG CLAMP

11.1 Cut rubber bungs: Ease leads individually into cuts in bung. Press leads down until they seat in holes in bung.

11.2 Uncut rubber bungs: Support bung in vice. Using a sharp knife, cut slots from outside circumference of bung into each hole required for use. Do not use a hacksaw blade to cut slots.

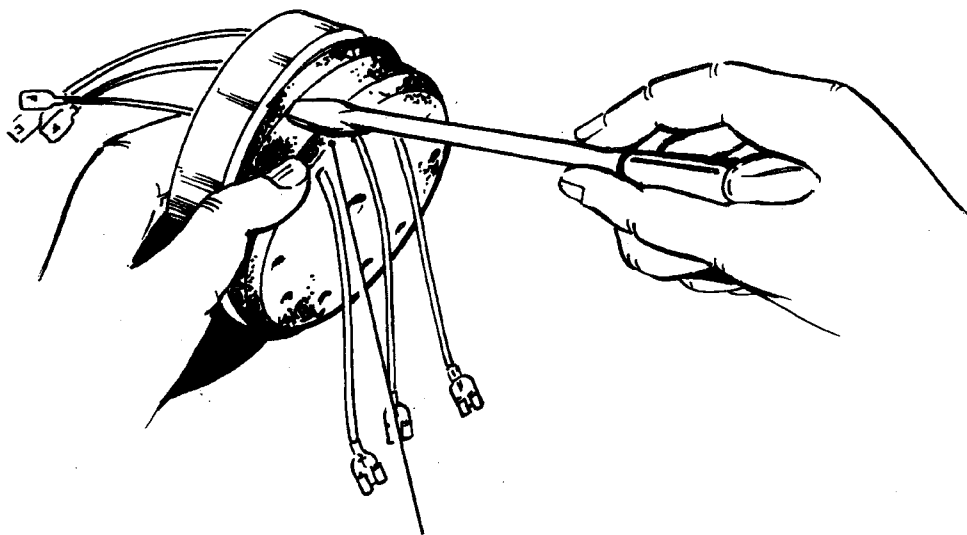

11.3 Press bottom of bung into bottom of clamp. Holding bung and clamp in one hand, ease bung into clamp with an electrician's screwdriver until circumferential lips of bung lie evenly on either side of clamp. Use the same method when fitting bung into a waterproofing box ring.

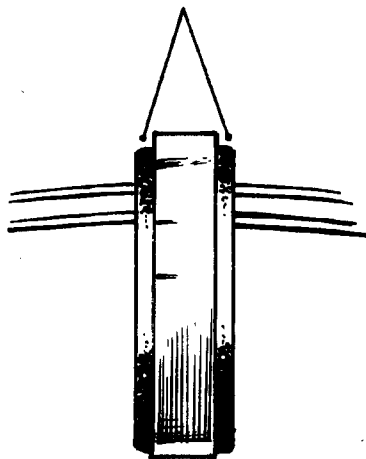
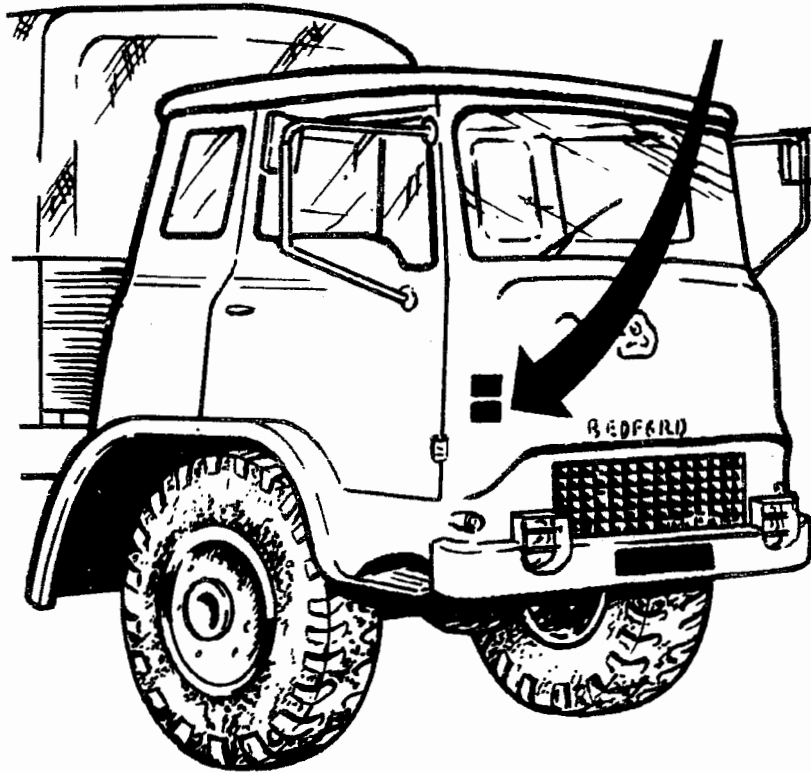

Fig 2. Fitting bung to bung clamp

12. WATERPROOFED EQUIPMENT MARKINGS

'B' Vehicles, Trailers and
RE Equipments
Top of offside (R.H.) front
wing.



Colour meaning	Where affixed	By whom
A		
Blue with white 'A' in centre	<u>SEMI-PERMANENT</u> Stage A completed	Unit lines Waterproofing Supervisor
B		
Red with white 'B' in centre	<u>SEMI-PERMANENT</u> Stage A checked Stage B completed Equipment passed for disembarkation	Embarkation Area or on Landing Craft Waterproofing Supervisor
<p>Note:</p> <p>The Stage B marking must be covered with 1 in. black adhesive tape when Stages C or D have been completed. The marking must be uncovered when Stage B is completed for further fording operations.</p>		

Fig 3 Waterproofed equipment markings

13. SECURING CABLE TIES

13.1 Position rubber cover over bung clamp, encircle bung clamp with cable tie and pull tightly ensuring that cable tie is located centrally over bung clamp.

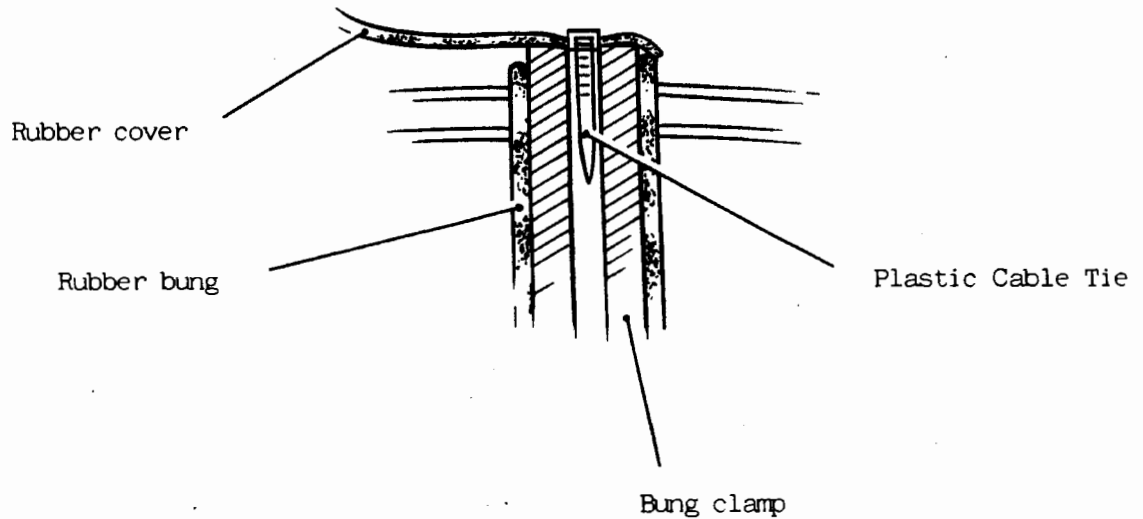

Fig 4 Securing cable ties

WATERPROOFING STAGE ATASK 1. BATTERIES (2)

Remove battery cover and disconnect batteries. Remove batteries. This is done to prevent accidental short circuiting during waterproofing of vehicle. Batteries will be refitted and connected in a later task.

TASK 2. REMOVAL OF ITEMS OF EQUIPMENT

THIS TASK TO BE CARRIED OUT WITH THE ASSISTANCE OF A VEHICLE, MECHANIC

Remove the following items:-

1. Engine radiator grill.
2. Engine top cover and seats.
3. Engine air filter.
4. Clutch underpan.
5. Spare wheel.
6. Expel all air from braking system.

TASK 3. GENERATOR

THIS TASK TO BE CARRIED OUT WITH THE ASSISTANCE OF A VEHICLE MECHANIC.

1. Disconnect plug and remove end cover; release regulator from generator to allow easier access to slipring housing.

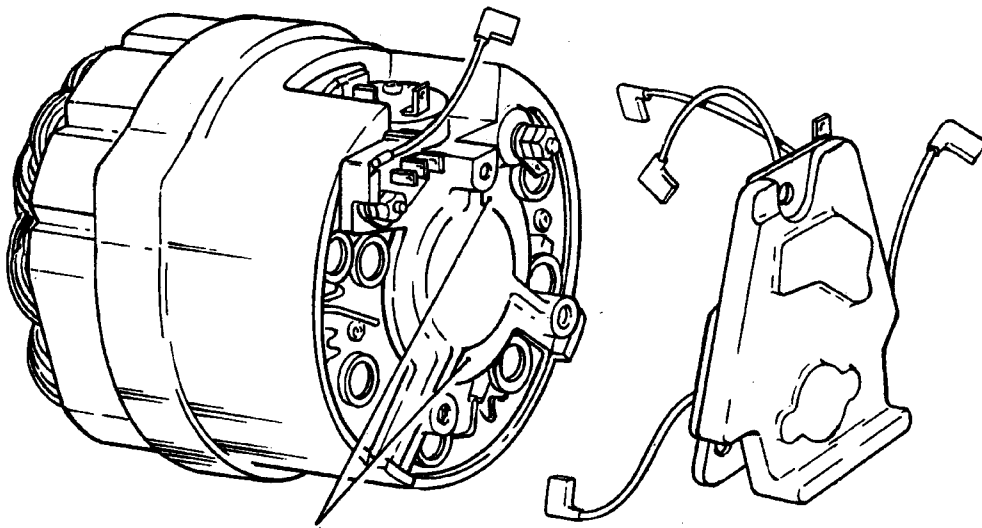

2. Mark the slipring housing at the highest and lowest points relative to the position of generator as fitted on the vehicle.

3. Remove generator from the vehicle. Remove brush gear; remove rotor complete with pulley and end plate from stator housing.

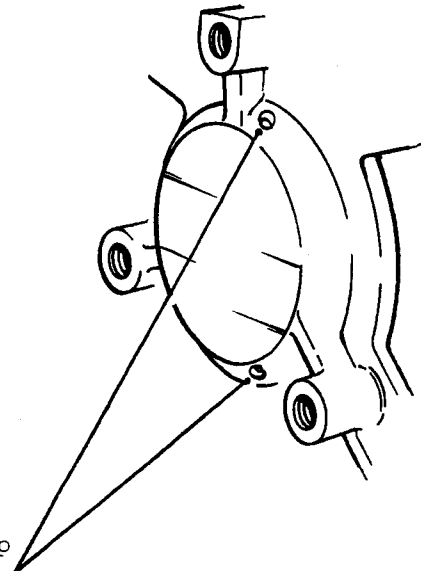

4. Carefully drill two 4.8 mm dia. holes in slip marked.

TASK 3. GENERATOR (continued)

5. Immerse stator assembly, open end first, in PX-24. DO NOT allow diodes and connections in end plate to contact PX-24. Remove stator and allow surplus PX-24 to drain.

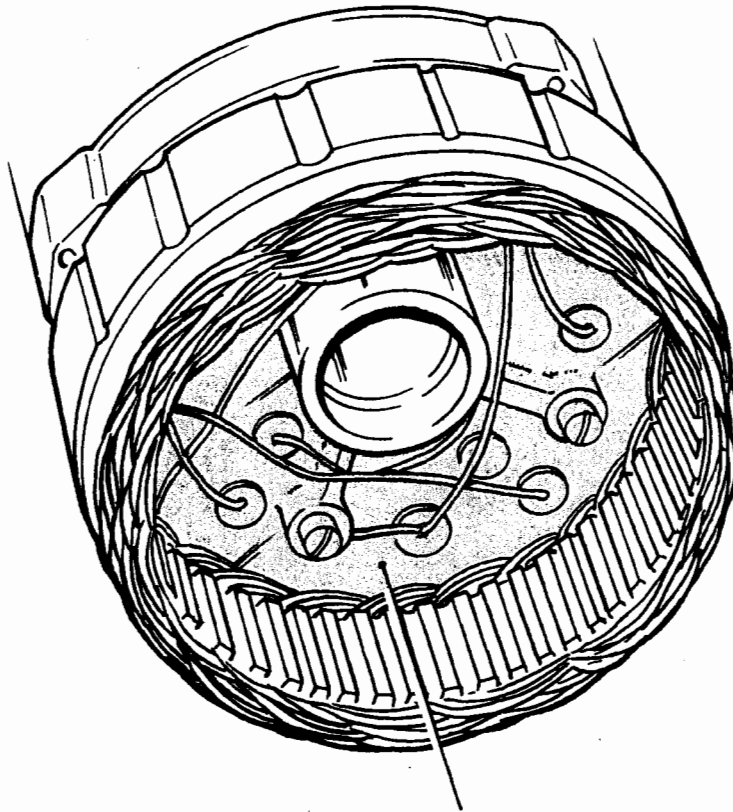

6. Apply a coat of silicone compound over rectifying diodes, wiring and connections on inside of stator housing.

Note ...

The application of this protective covering of silicone compound is IMPORTANT and care must be taken to ensure that an unbroken film is applied over terminal ends of diodes.



Compound Silicone

TASK 3. GENERATOR (continued)

7. Bind adhesive tape over end of shaft, over slip rings, over bearing and onto rotor. This is to prevent PX-24 contaminating bearing lubricant

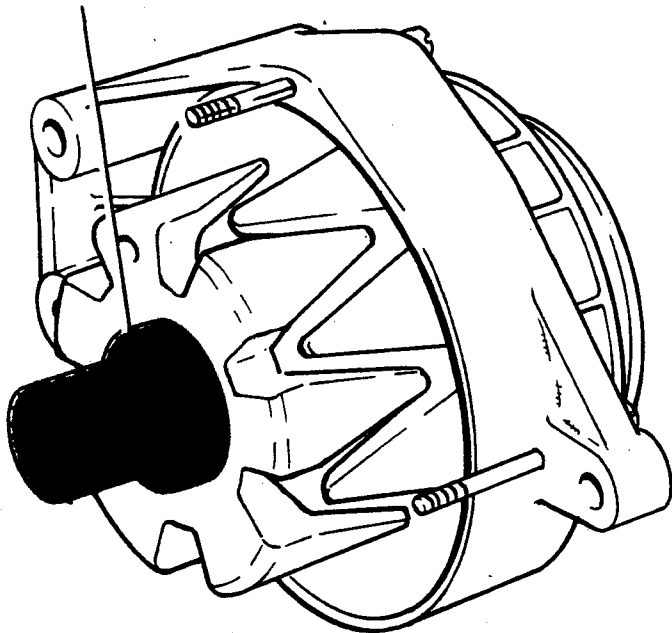

8. Immerse rotor assembly in PX-24 ensuring that drive end bearing does not contact fluid. Remove rotor and allow surplus PX-24 to drain.

9. apply a FILM of Silicone Compound to as much of the sides of the brushes (2) as possible.

Note ...

Do not allow the contact surfaces of the brushes or sliprings to become covered with Silicone Compound.

10. Remove adhesive tape from sliprings and bearing. Re-assemble stator and rotor. Refit brush gear.

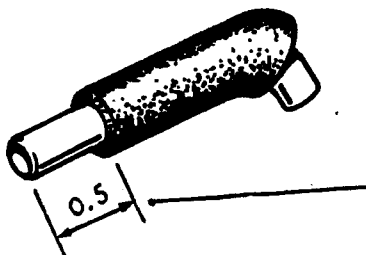

11. Examine adaptor, slipring housing, 6WPG 2920 99 819 1611 (WPG 9176) and ensure that rubber tubing is positioned 0.5 in. from end of piping as shown.



Tape, adhesive



Compound Silicone

TASK 3. GENERATOR (continued)

12. Cut a 610 mm length of 5/32 in. i.d. rubber tubing 6MT6 4720 99 805 7764. Fit one end of tubing over long end of slipping housing adaptor.

13. Push short end of slipping housing adaptor into top hole previously drilled in housing, as shown. Ensure that adaptor is a firm fit in hole.

14. Apply an even coat of silicone compound over diodes and capacitor connections.

Note ...

Do not apply silicone to earth lead connections.

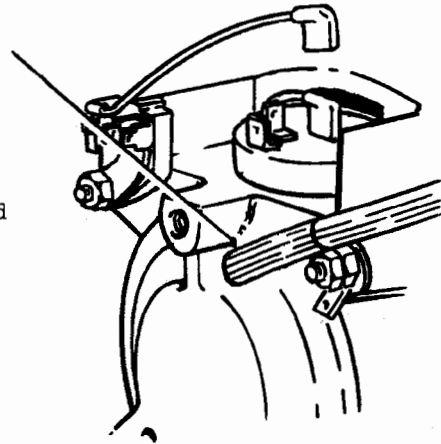
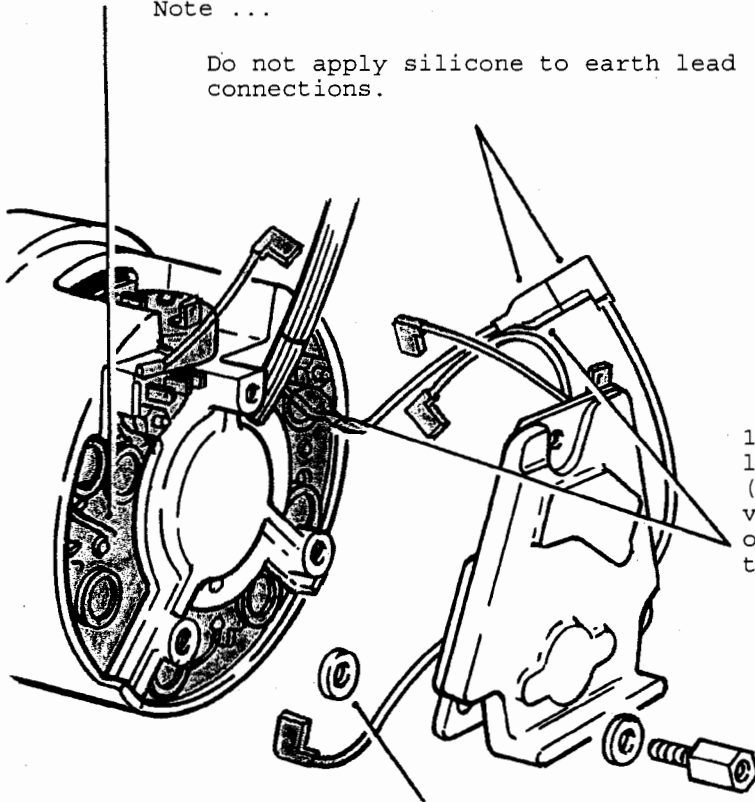

15. Fit male end of extension lead 6WPG 2920 99 731 5176 (WPG 9376) to black wire on voltage regulator. Fit the other end of lead to earth terminal on generator.

16. Refit regulator using flat washer G1 5310 99 122 8065 supplied as a distance piece between stator body and regulator on each screw. Reconnect leads to brush gear, apply a coat of silicone compound over brush gear terminals.

17. Pass free end of 5/32 in. i.d. rubber tubing through earth terminal aperture of end cover. Refit end cover ensuring that extension lead to voltage regulator connection is outside cover. Refit generator, reconnect plug and adjust fan belts.

18. Pass 5/32 in. i.d. rubber tubing between handbrake cable and cab body. Secure tubing to battery leads with adhesive tape.



Compound silicone

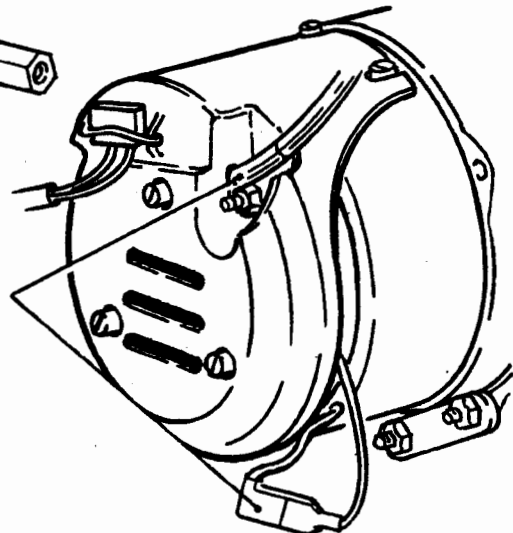

TASK 4. CLUTCH HOUSING

THIS TASK TO BE CARRIED OUT WITH THE ASSISTANCE OF A VEHICLE MECHANIC.

1. In this task, two coats of EC-750-C are required to be applied. Allow first coat to dry before applying the second coat.
2. Remove clutch rod and return spring.
3. Remove starter motor; it will be refitted in a later task.

4. Cover hole in flywheel housing with a 25 mm length of adhesive tape. Mould 40 mm of Prestikon over taped hole.

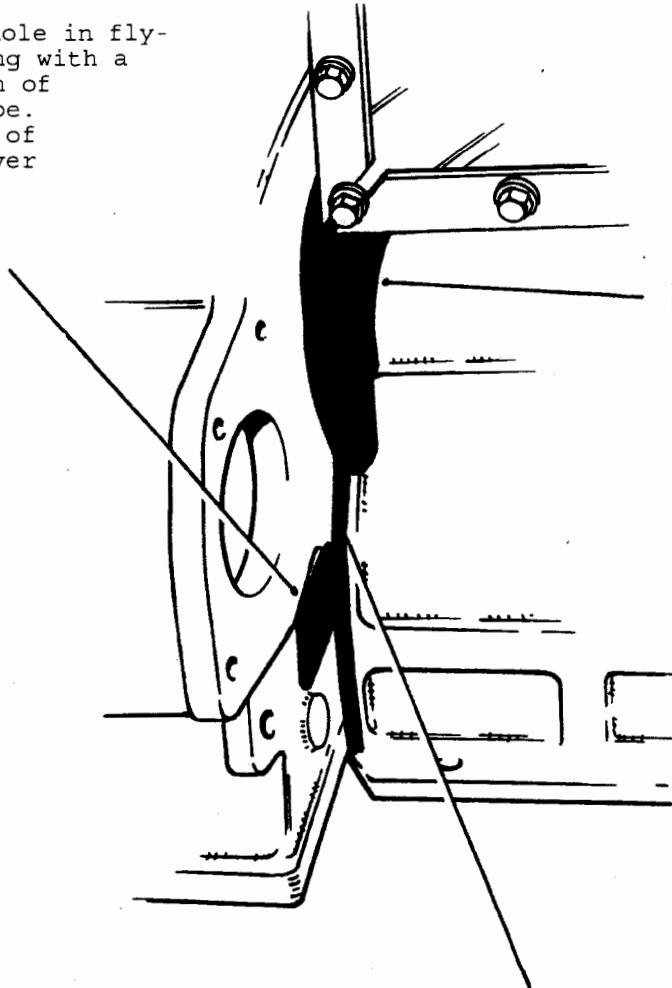

5. Mould 400 mm of Prestikon into recess between top of flywheel housing and crankcase and over joint of housing to crankcase as shown. Ensure that recess between flywheel housing and crankcase is completely filled with Prestikon.

6. Using brush, flat, fitch No. 6, apply EC-750-C sealant over flywheel housing to crankcase joint.

Note ...

Where difficulty is experienced in the adherence of Prestikon, apply a coat of Bostik 1GA 186 to the area where Prestikon is to be moulded. Allow Bostik to dry thoroughly before applying Prestikon.

■ Prestikon

■ EC-750-C

TASK 4. CLUTCH HOUSING (continued)

7. Mould 200 mm of Prestikon into remaining recess between flywheel housing and crankcase ensuring that recess is completely filled.

8. Mould 150 mm of Prestikon over grommet onto flywheel housing.

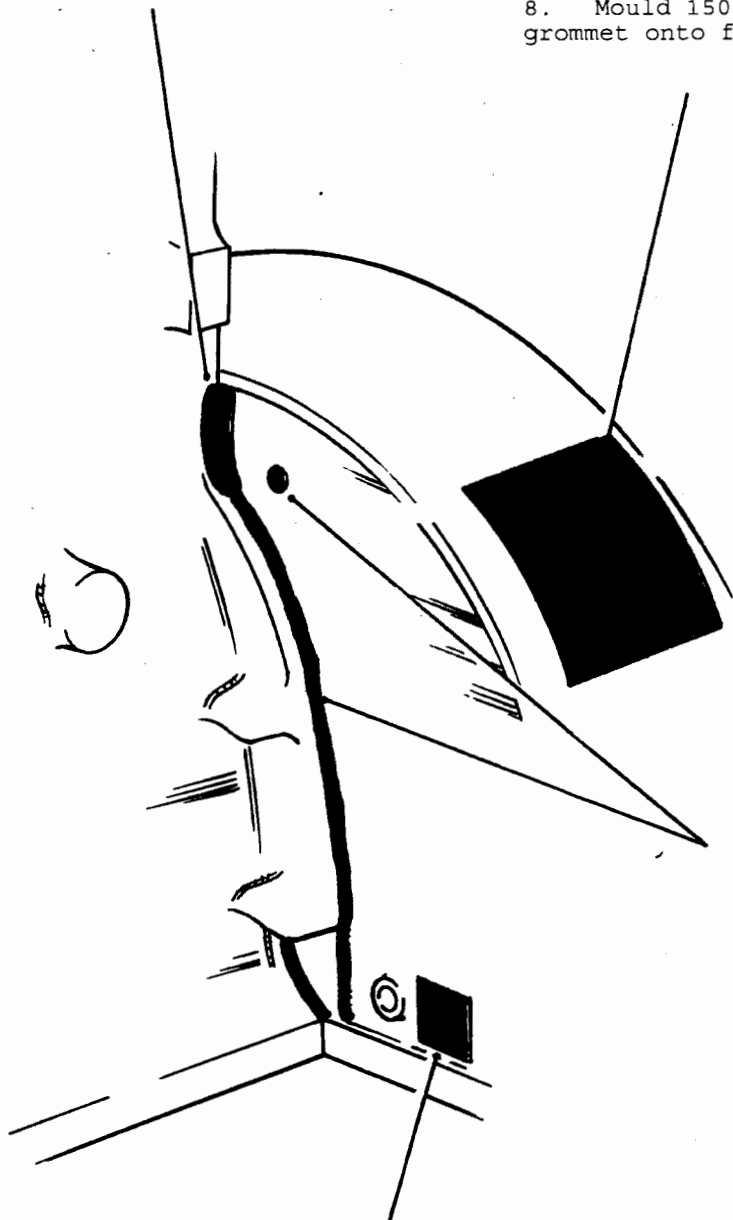

9. Apply a coat of EC-750-C sealant over remaining joint of flywheel housing to crankcase housing and to rivet head as shown.

10. Cover hole with 25 mm length of adhesive tape. Mould 40 mm of Prestikon over taped hole.

 Prestikon

 EC-750-C

TASK 4. CLUTCH HOUSING (continued)

11. Fit plug 9ASC 4730 99 815 6652 and fibre washer H9 5330 99 943 4400 to L.H. clutch lever pivot hole. Enter plug from inside clutch housing and ensure it is tight.

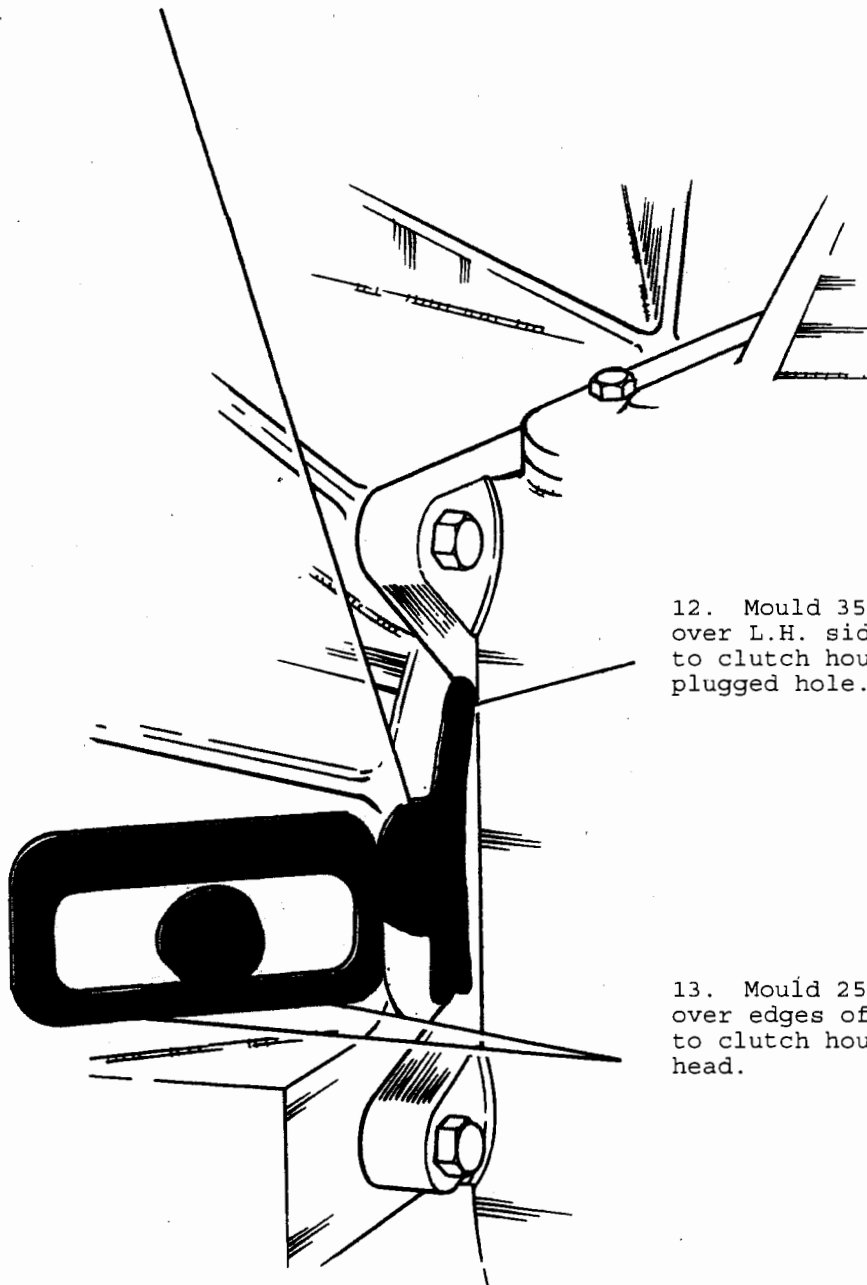

12. Mould 350 mm of Prestikon over L.H. side recess of gearbox to clutch housing joint and plugged hole.

13. Mould 250 mm of Prestikon over edges of cover plate and on to clutch housing and over screw-head.

Note ...

Ensure that gasket between clutch housing and gearbox is fitted and that it is in good condition.

 Prestikon

TASK 4. CLUTCH HOUSING (continued)

14. Mould 350 mm of Prestikon over R.H. side recess of gearbox to clutch housing joint and over clutch lever pivot hole.

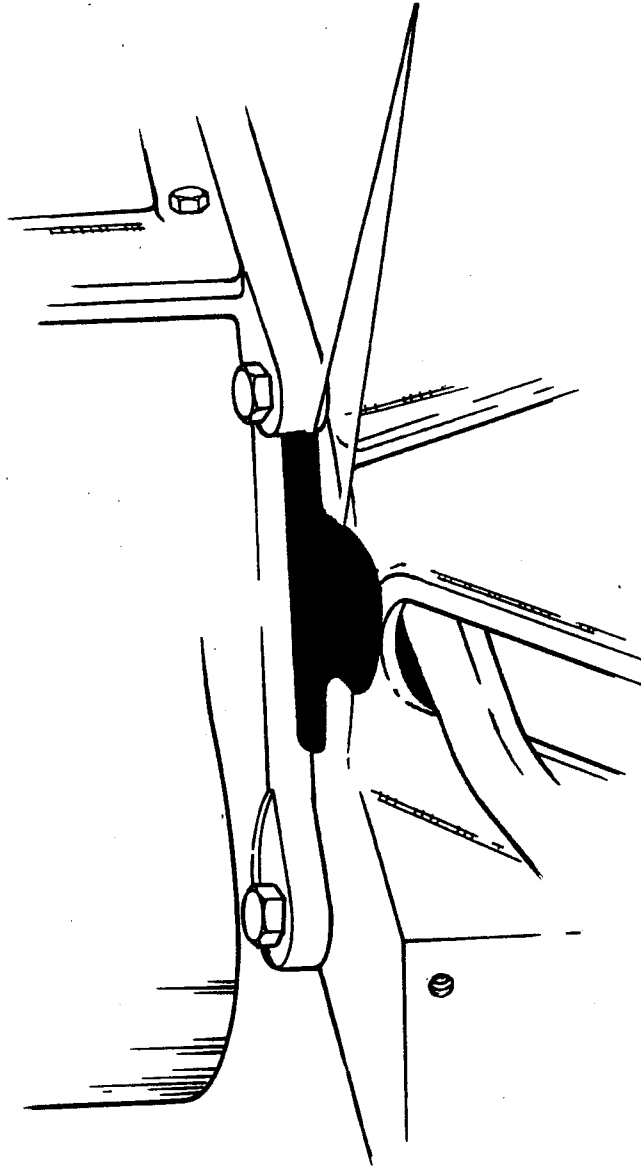

 Prestikon

TASK 4. CLUTCH HOUSING (continued)

15. Mould sufficient Prestikon into drilled holes in flywheel housing to fill holes, (one each side of flywheel housing) and form watertight seal.

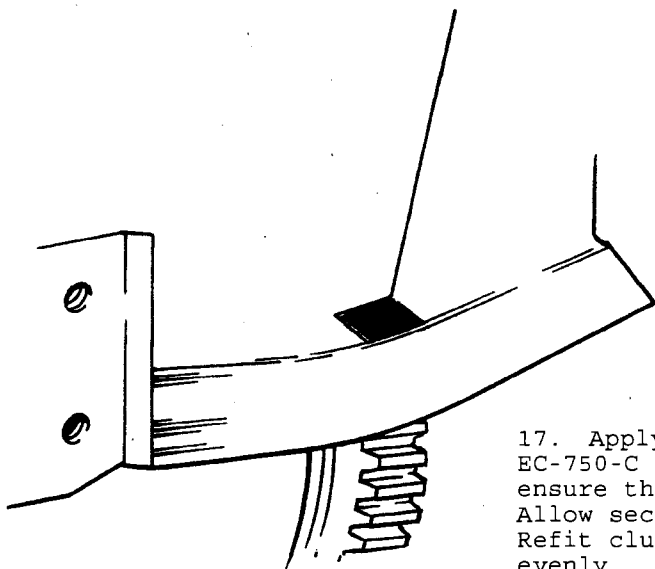

16. Remove split pin from drain hole of clutch underpan and stow in a safe place on vehicle.

17. Apply a liberal even coat of EC-750-C over flange of underpan; ensure that bolt holes are kept clear. Allow second coat to become almost dry. Refit clutch underpan; tighten bolts evenly.

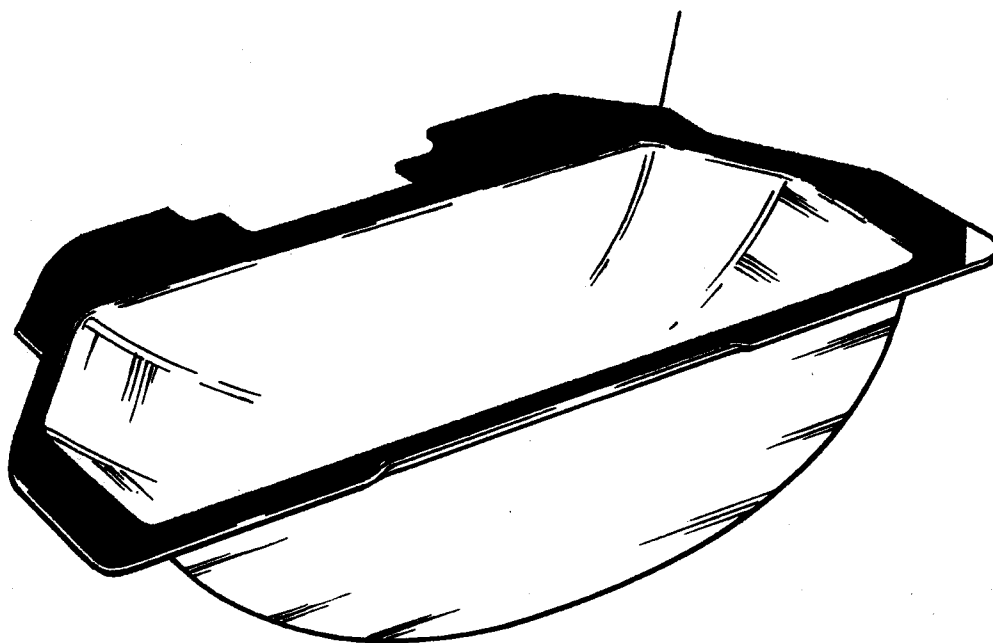

 Prestikon

 EC-750-C

TASK 4. CLUTCH HOUSING (continued)

18. Mould 400 mm of Prestikon into and over joint of clutch pan to gearbox end cap as shown.

19. Mould 300 mm of Prestikon into and over joint of clutch pan to engine crankcase as shown.

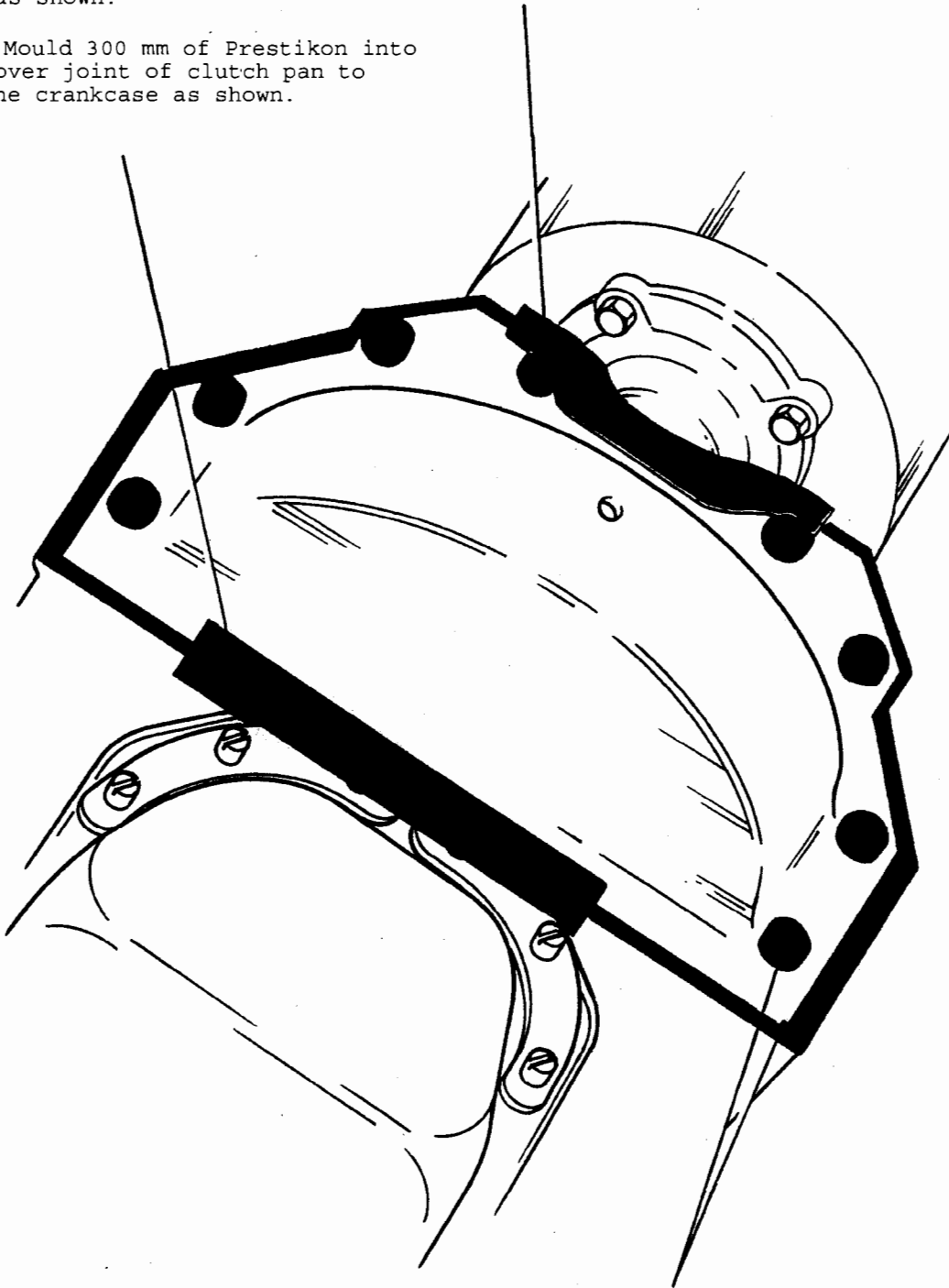

20. Apply a liberal, even coat of EC-750-C over each bolt head and edge of pan on to flywheel housing.

Note ...

The clutch pan drain hole will be sealed at a later stage. (Task 62).

 Prestikon

 EC-750-C

TASK 5. CLUTCH OPERATOR LEVER

THIS TASK TO BE CARRIED OUT WITH ASSISTANCE OF A VEHICLE MECHANIC.

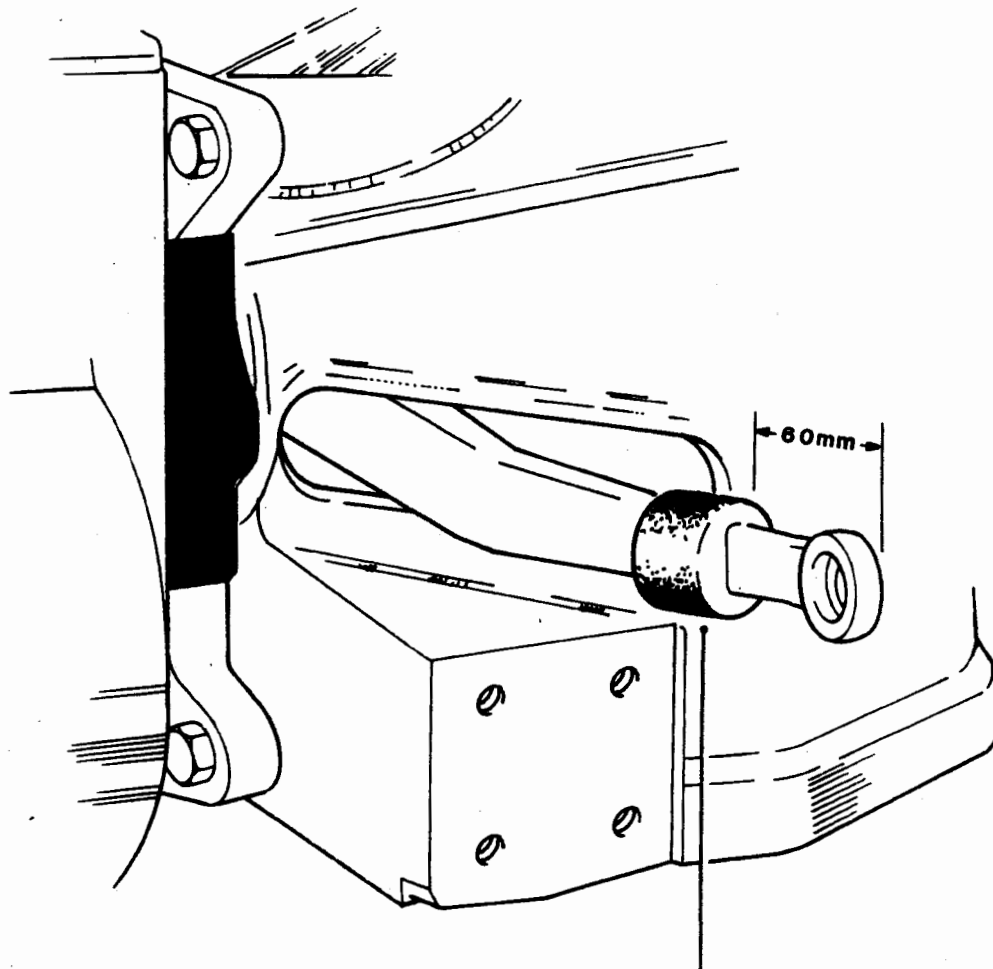

1. Fit hose, rubber, $\frac{3}{4}$ in. i.d. x 1.1/8 in. o.d. x 40 mm long over end of lever in position shown. Silicone compound, water or similar lubricant will assist in fitting rubber hose on lever.

 Prestikon

TASK 5. CLUTCH OPERATING LEVER (continued)

2. Apply an even coat of EC-750-C over the outside surface of gaiter, clutch lever (WPG 9221). Allow to dry.

3. Apply a coat of Bostik 1GA 186 over both sides of gaiter flange and around clutch lever aperture for a width of 40 mm.

4. Mould 250 mm of Prestikon over Bostik already applied around aperture, to form a base for gaiter flange.

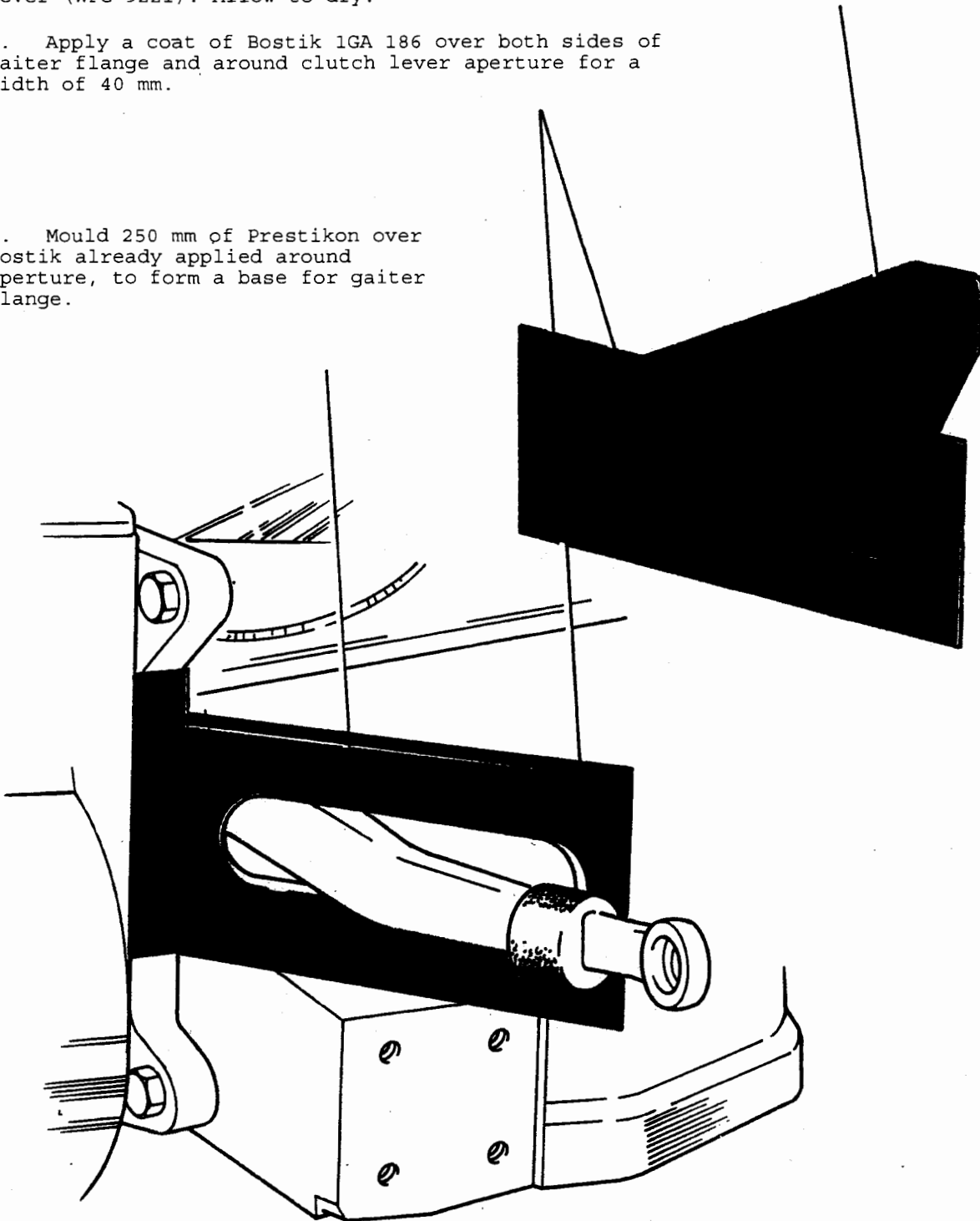

5. Fit gaiter over lever with wide edges of flange to the top and front. Press gaiter flange firmly on to Prestikon base.

Prestikon
 Bostik 1GA 186
 EC-750-C
 Wading Fabric

TASK 5. CLUTCH OPERATING LEVER (continued)

6. Position small end of gaiter flush with end of rubber hose and secure with a hose clamp 22 mm - 30mm i.d.

7. Mould 25 mm of Prestikon over gaiter flange and onto clutch housing.

8. Apply an even coat of EC-750-C around end of rubber tubing on to lever.

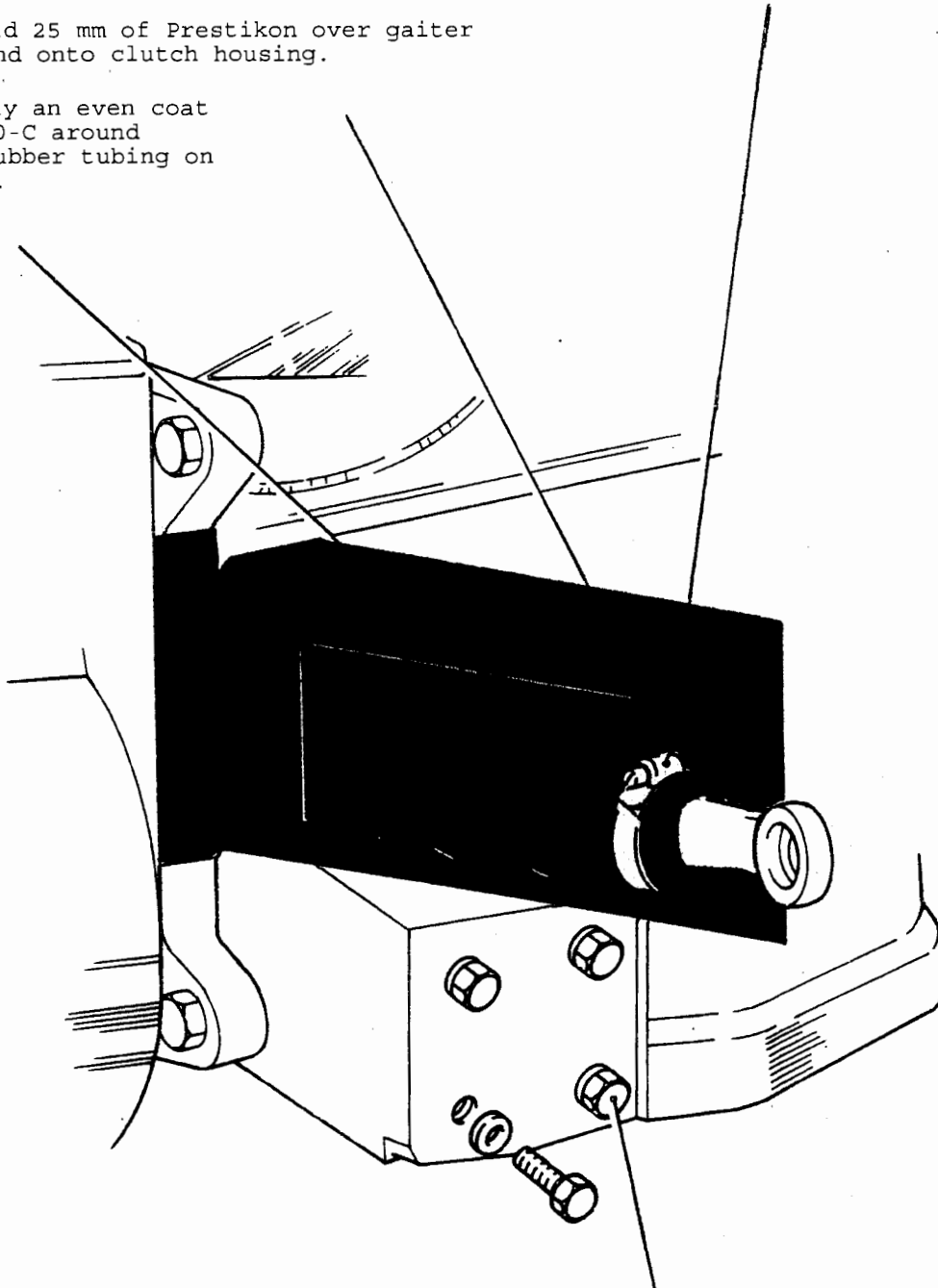

9. Fit four 7/16 UNC screws G1 5305 99 941 0725 and four fibre washers 6MT1 5310 99 801 4802 into the four tapped holes in R.H. torque reaction rod bracket mounting.

■ Prestikon

■ EC-750-C

TASK 6. STARTER MOTOR

THIS TASK TO BE CARRIED OUT WITH THE ASSISTANCE OF A VEHICLE MECHANIC

1. All seals that are suspect must be renewed.
2. Ensure that sealing rings, washers and gaskets are correctly fitted.

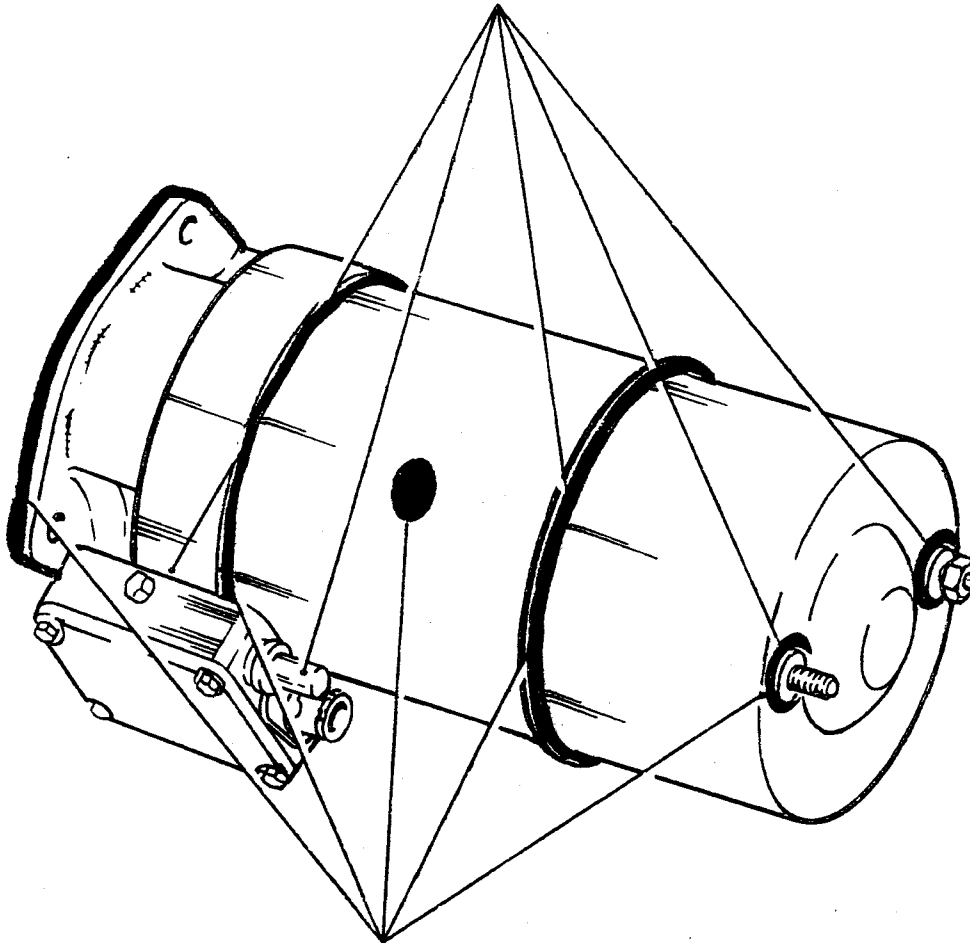

3. Apply an even coat of EC-750-C over starter motor mounting flange face, over yoke to drive end shield joint, over each pole screw head onto yoke, over commutator end cap joint to yoke and around terminal basis onto commutator end cap. Allow to dry.

 EC-750-C

TASK 6. STARTER MOTOR (continued)

4. Apply an even coat of EC-750-C around starter motor mounting hole. Refit starter motor, tighten bolts evenly, reconnect leads.

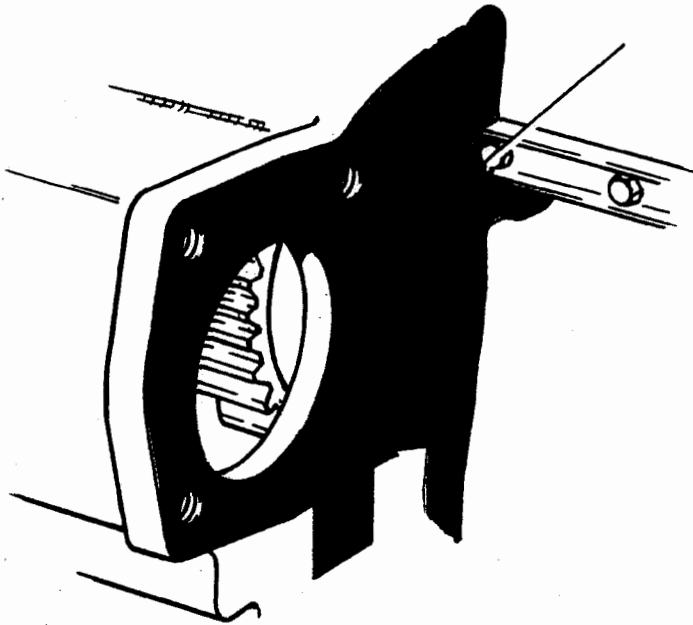

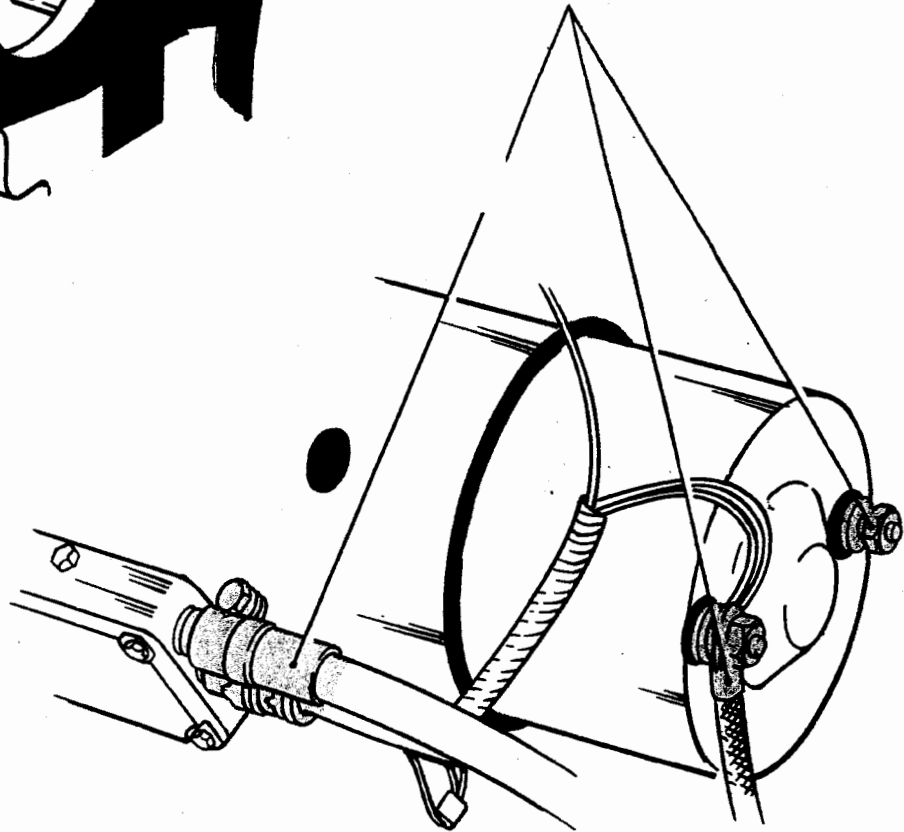

5. Apply an even coat of silicone compound over lead connections and terminals.



6. Refit clutch operating rod and spring. Re-adjust clutch pedal free play 1.0 in. (25 mm).

 Prestikon

 EC-750-C

 Compound, silicone

TASK 7. GEAR LEVER

1. Release spring clip from top of rubber gaiter.
2. Secure top of rubber gaiter with a plastic cable tie 6MT4 5340 99 820 5371.

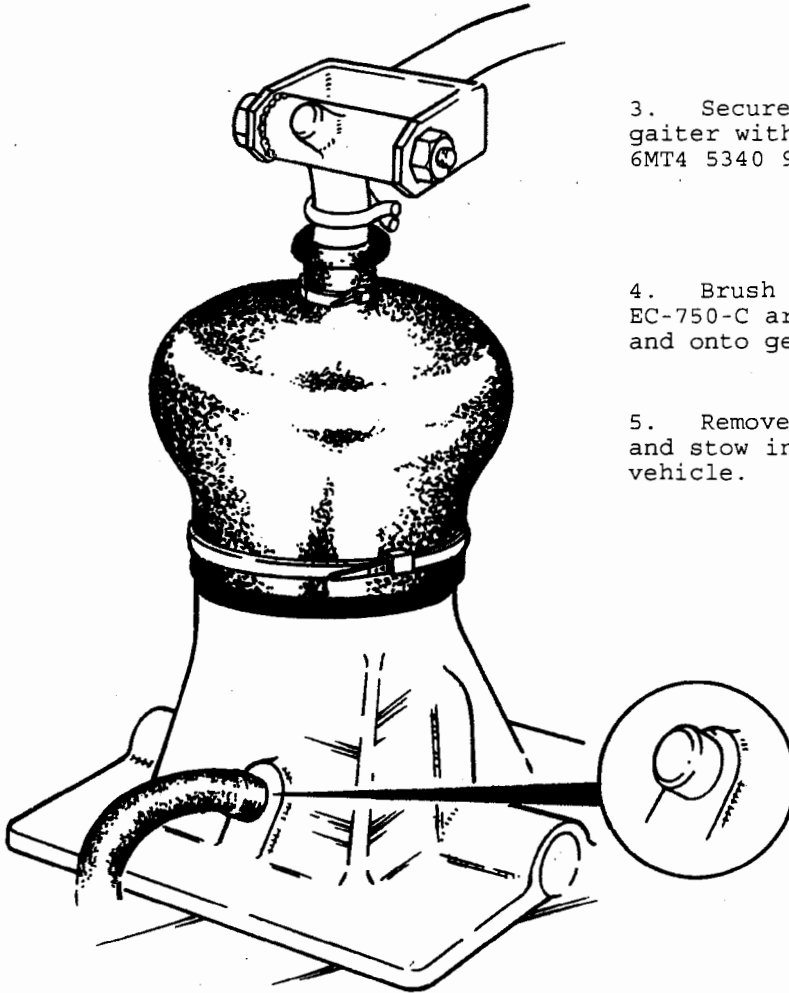

3. Secure bottom of rubber gaiter with plastic cable strap 6MT4 5340 99 742 6346.

4. Brush an even coat of EC-750-C around base of gaiter and onto gearbox casing.

5. Remove gearbox breather cap and stow in a safe place in the vehicle.

6. Push one end of a 2 metre length of 7/32 in. i.d. rubber tubing 6MT6 4720 99 805 7839 over gearbox breather as far as it will go. Coil remaining length and stow on top of gearbox or any suitable position. The breather hose will be secured in its final position at a later stage (Task 35).

 EC-750-C

TASK 8. SPEEDOMETER CABLE

1. Brush a liberal, even coat of EC-750-C over speedometer cable, over drive flange and onto transfer box casing.

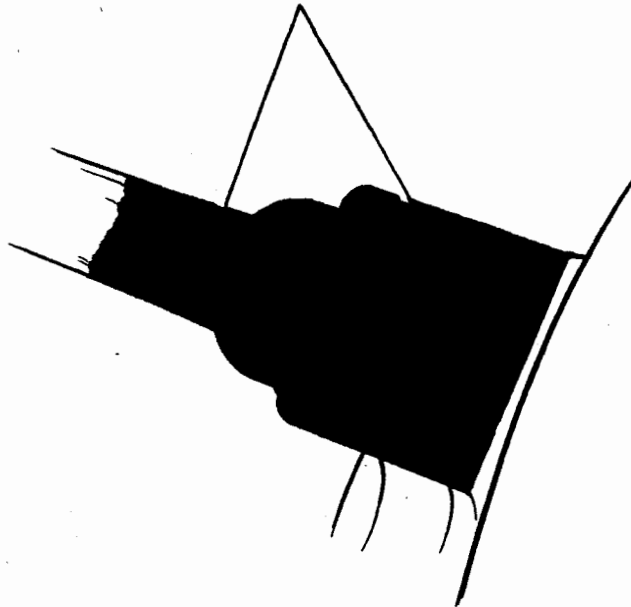

2. Brush a liberal, even coat of EC-750-C over speedometer drive blanking plate onto casing on R.H. side of gearbox.

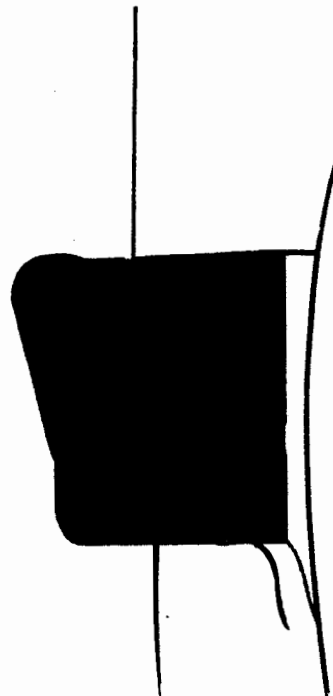

 EC-750-C

TASK 9. BRAKE CONDENSING RESERVOIR

1. Remove rubber dust cover from safety valve and stow in a safe place in the vehicle.

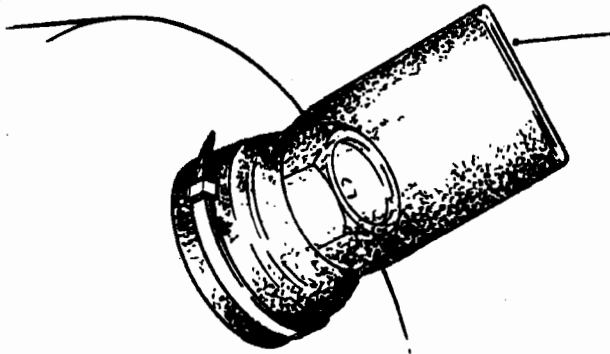

2. Fit a 1.1/4 in. dia. non-return valve 6WPG 2540 99 818 8177 (WPG 9173) over safety valve boss and secure with a plastic cable tie 6MT4 5340 99 820 5371.

3. Fit a 1/2 in. dia. non-return valve 6WPG 2540 99 817 6915 (WPG 9137) over automatic drain valve outlet and secure with a plastic cable tie 6MT4 5340 99 820 5371.

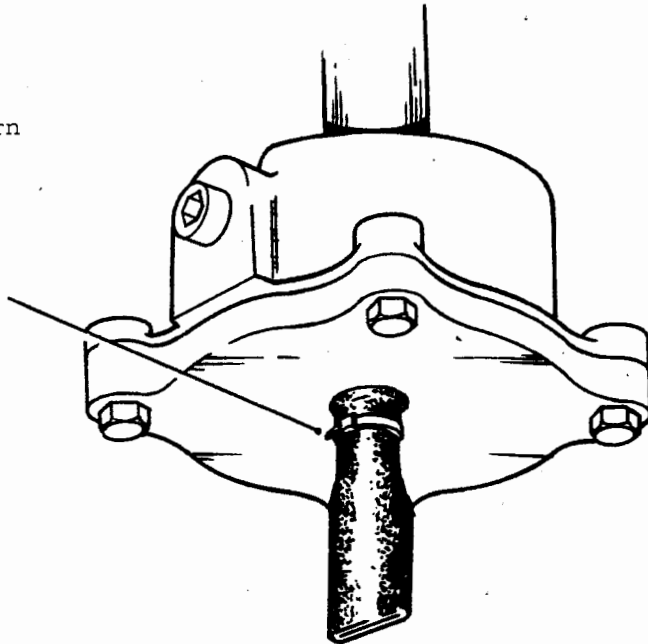



TASK 10. TRIPLE SYSTEM PROTECTION VALVE

Note ...

Triple system protection valve is located on L.H. side of cross member immediately behind gearbox.

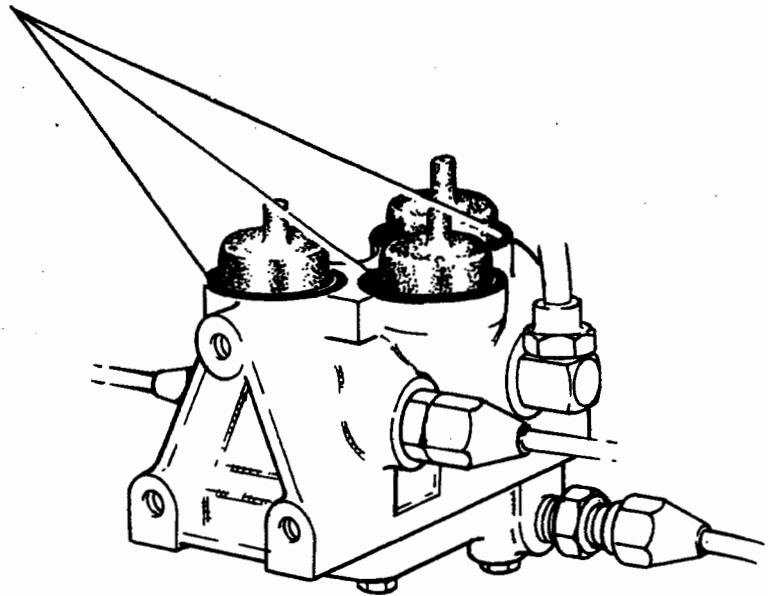
1. Apply a liberal, even coat of EC-750-C around edges of gaiters and onto valve body.



 EC-750-C

TASK 11. BRAKE RELAY VALVE

THIS TASK TO BE CARRIED OUT WITH THE ASSISTANCE OF A VEHICLE MECHANIC

Note ...

Brake relay valve is located on R.H. side of cross member immediately behind gearbox.

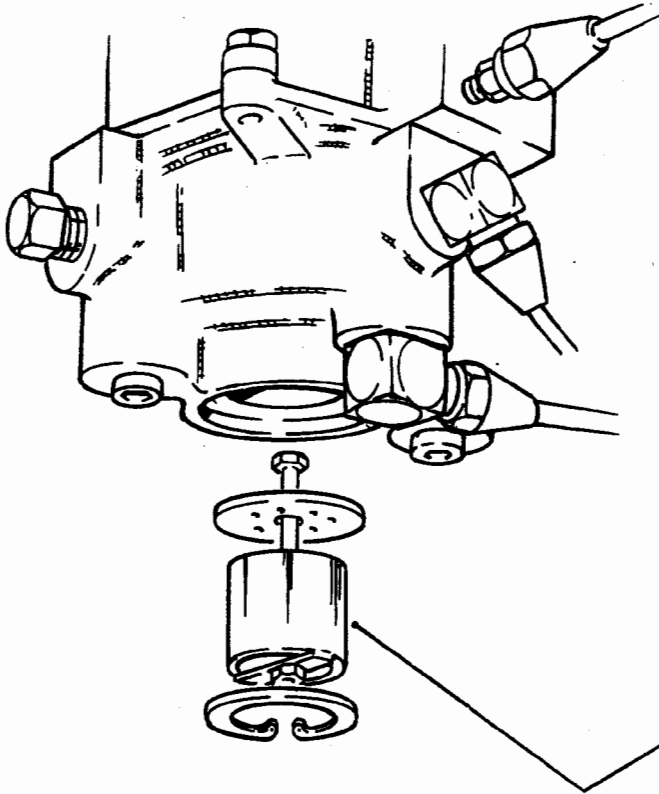

1. Remove relay unit from vehicle.

2. Remove circlip and withdraw exhaust diaphragm plate. Remove diaphragm from diaphragm plate and stow in a safe place in vehicle.

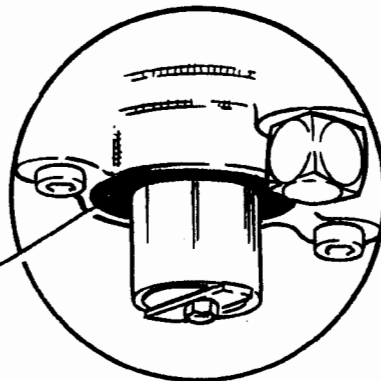

3. Using adaptor 6WPG 2540 99 838 9990 (WPG 9358) assemble adaptor as shown passing adaptor fixing bolt through centre hole of diaphragm plate and adaptor. Refit diaphragm plate and adaptor to relay valve. Refit circlip. Brush an even coat of EC-750-C around circlip onto relay valve body and diaphragm plate and around join of adaptor to diaphragm plate.

4. Fit a 1 1/4 in. dia. non-return valve 6WPG 2540 99 818 8177 (WPG 9173) and secure with plastic cable tie 6MT4 5340 99 820 5371.

5. Refit brake relay valve onto vehicle.

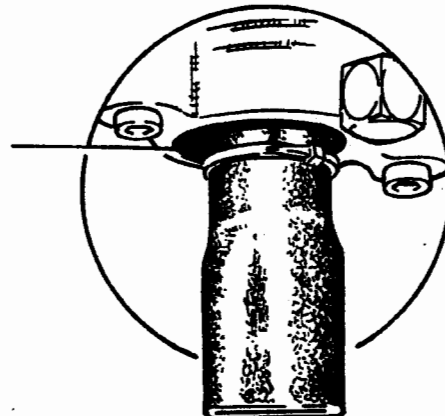

■ EC-750-C

TASK 12. AIR PRESSURE LOSS LIMITING VALVE

Note ...

Air pressure loss limiting valve is located on inside of chassis behind transfer box on the L.H. side of vehicle.

1. Apply an even coat of GREASE over top of valve. Ensure that vent hole is covered.

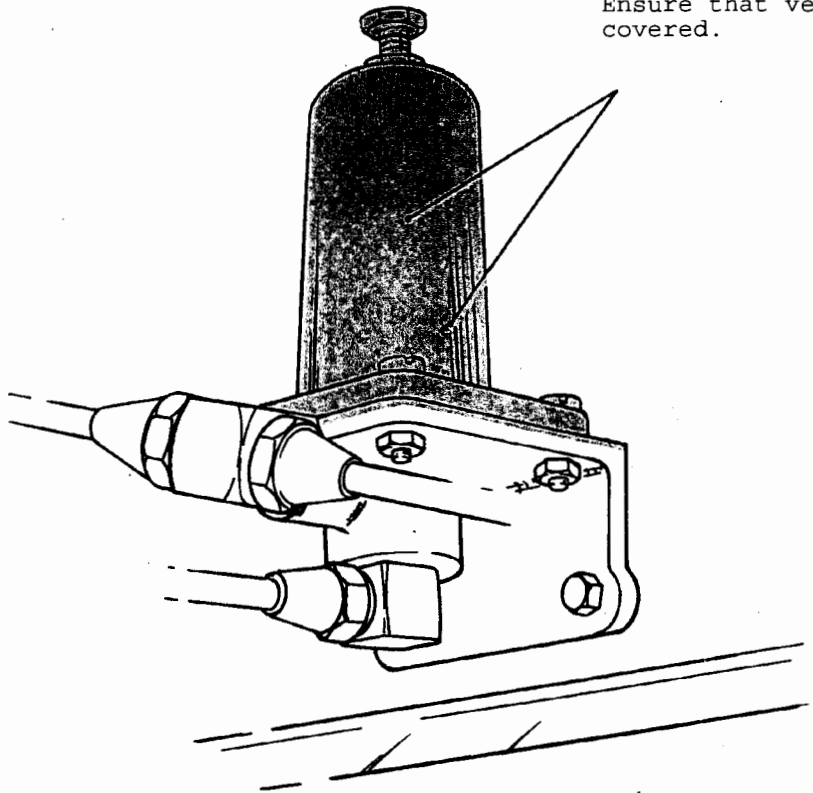

 Grease

TASK 13. COMPRESSOR GOVERNOR VALVE

Note ...

Compressor governor valve is located on inside of chassis on L.H. side of vehicle adjacent to the fuel injection pump.

1. Release governor valve from its position on chassis; there is no need to disconnect any pipes.

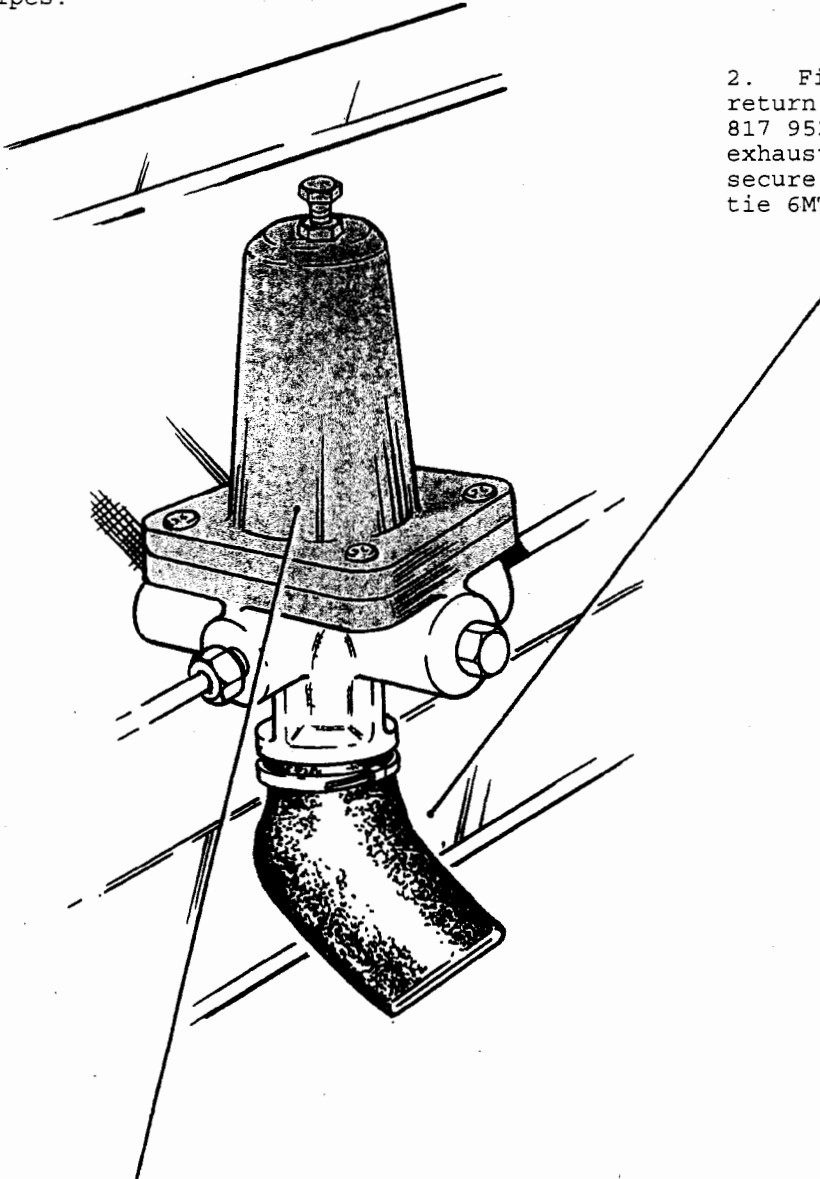

2. Fit a 1 in. dia. non-return valve 6WPG 2540 99 817 9527 (WPG 9157) over exhauster valve nut and secure with a plastic cable tie 6MT4 5340 99 820 5371.

3. Apply an even coat of GREASE over top of valve.

 Grease

TASK 14. LOAD SENSING VALVE

Note ...

Load sensing valve is located on inside of rear chassis cross member behind rear axle.

1. Apply a liberal, even coating of GREASE around valve push rod, over rubber boot and onto valve casing.

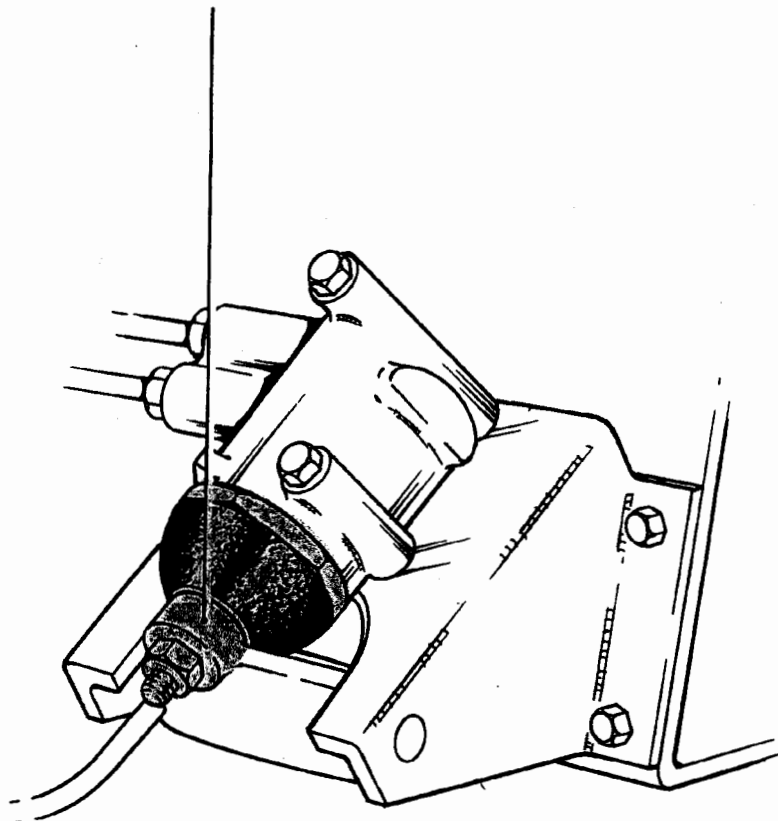

 Grease

TASK 14. LOAD SENSING VALVE (continued)

2. Apply a liberal, even coating of GREASE on adjusting threads and locknuts.

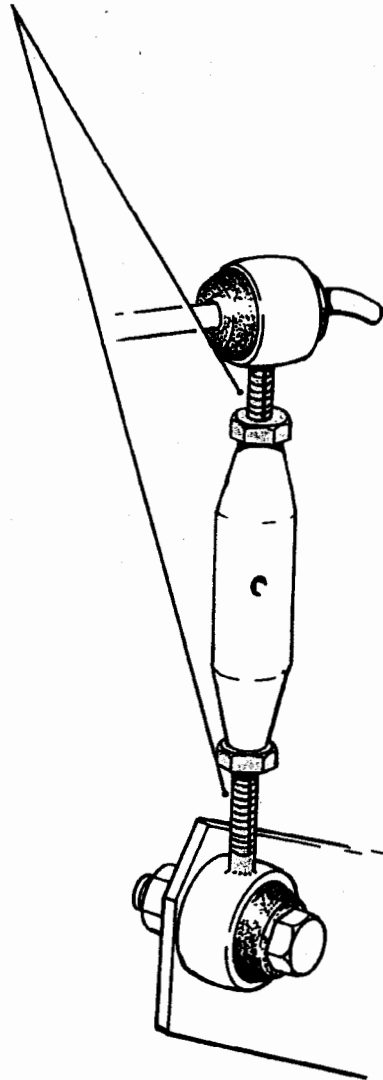

Grease

TASK 15. FOOTBRAKE VALVE

Note ...

Footbrake valve is located on outside of chassis adjacent to R.H. front wheel.

3. Fit a 1 in. dia. non-return valve 6WPG 2540 99 817 9527 (WPG 9157) over exhaust diaphragm boss and secure with plastic cable tie 6MT4 5340 99 820 5371.

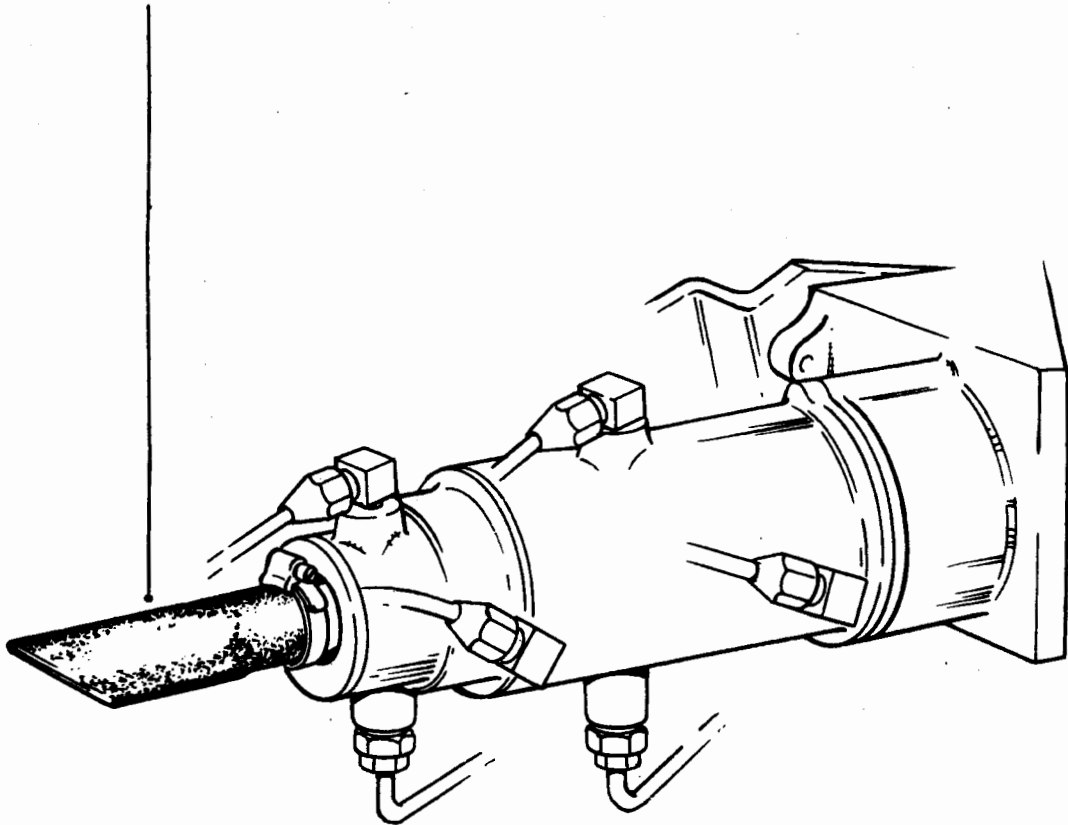

TASK 16. BRAKE MASTER CYLINDER ACTUATOR

THIS TASK TO BE CARRIED OUT WITH THE ASSISTANCE OF A VEHICLE MECHANIC.

Note ...

Actuator is located on the outside of chassis on R.H. side of vehicle.

1. Mark cylinders and body to ensure correct alignment on re-assembly.
2. Disconnect air lines from actuator. Remove actuator securing nuts, and withdraw from bracket. DO NOT REMOVE BRAKE MASTER CYLINDER.
3. Remove bolts and separate both front and rear actuator cylinders from body. Remove filter mesh from breather hole in centre body.

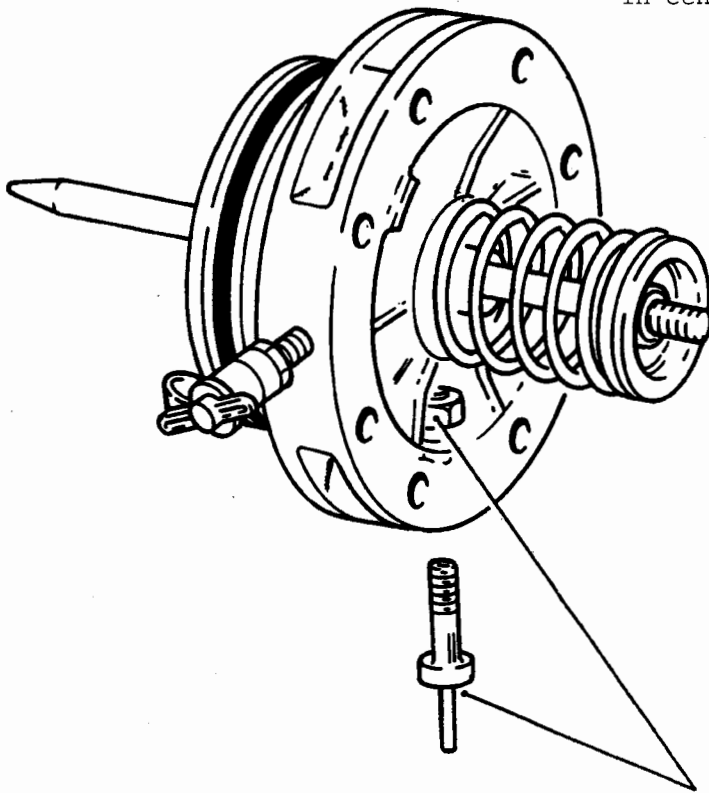

4. Fit adaptor breather actuator No 5 6WPG 4730 99 419 9080 (WPG 9396) into breather hole and secure with nut.

TASK 16. BRAKE MASTER CYLINDER ACTUATOR (continued)

5. Remove filter mesh from breather hole in front cylinder and stow in a safe place in the vehicle.

6. Fit adaptor breather actuator No. 4 6WPG 4730 99 526 0422 (WPG 9395) and secure with nut. Ensure that adaptor is parallel to studs.

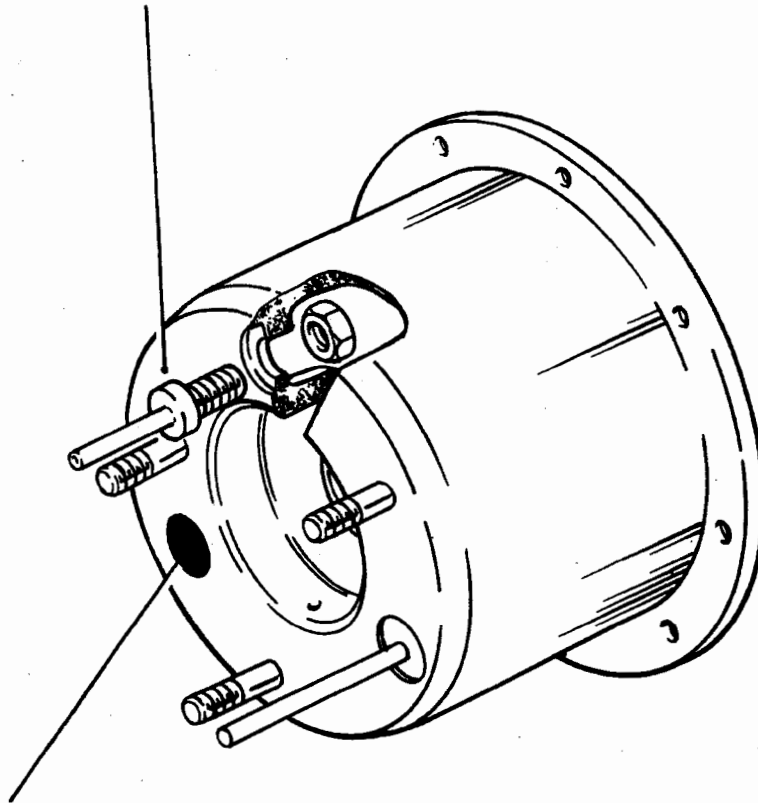

7. Fill hole in cylinder, with EC-750-C. DO NOT REMOVE PLASTIC BLANKING PLUG.

 EC-750-C

TASK 16. BRAKE MASTER CYLINDER ACTUATOR (continued)

8. Remove split pin from drain hole. Cover drain hole with a 25 mm length of adhesive tape. Brush a coat of EC-750-C over taped hole.

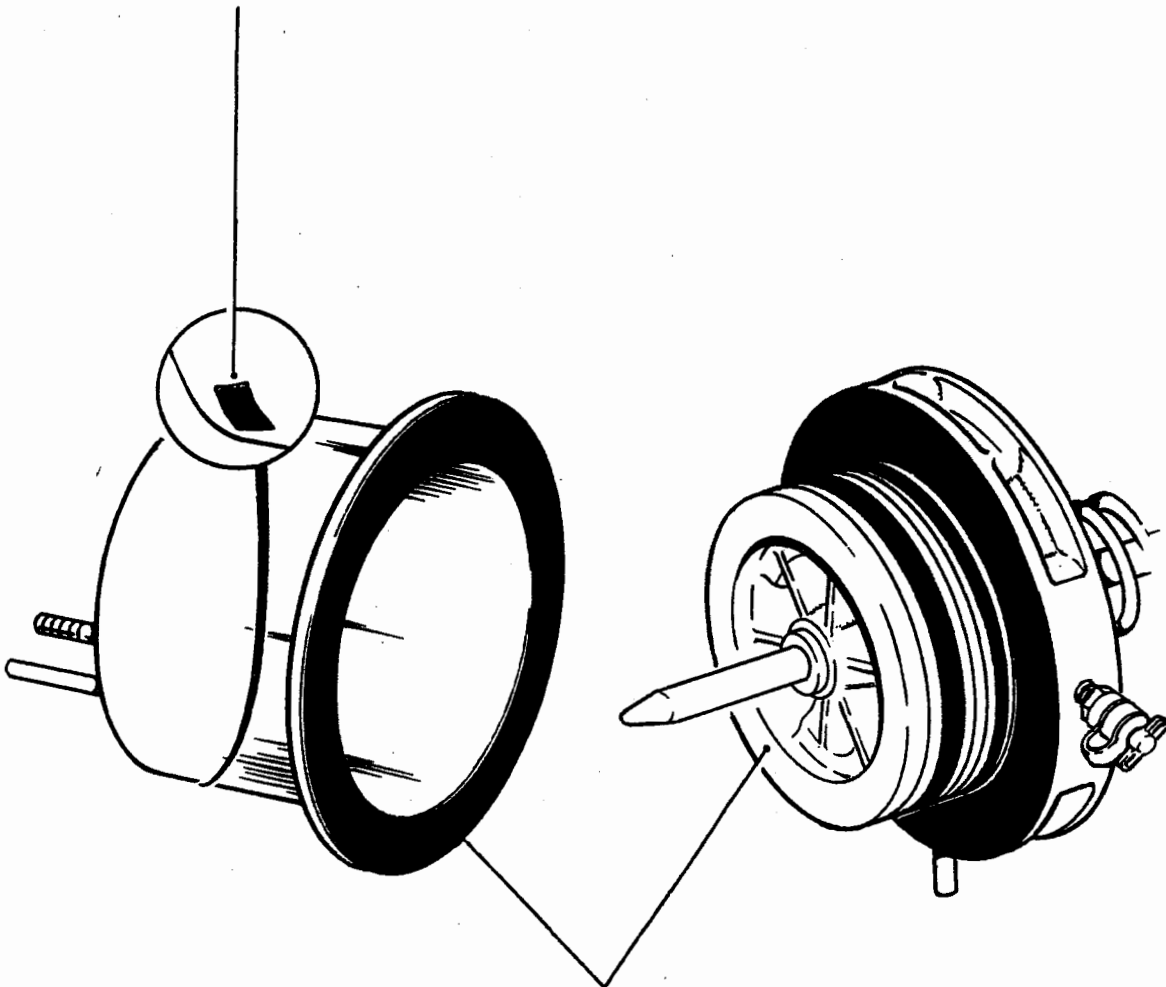

9. Brush an even coat of EC-750-C over mating surfaces of front cylinder and actuator body.

10. Ensure that gasket for rear cylinder is in position and while EC-750-C is still tacky on front cylinder, re-assemble actuator.

Note ...

On some actuators para 9 does not apply if gasket has been fitted by the manufacturers.

 EC-750-C

TASK 16. BRAKE MASTER CYLINDER ACTUATOR (continued)

11. Pull out indicator rod to its fullest extent.
12. Brush a coat of EC-750-C around base of breather adaptor, over face of cylinder and over inner mating face of support bracket.

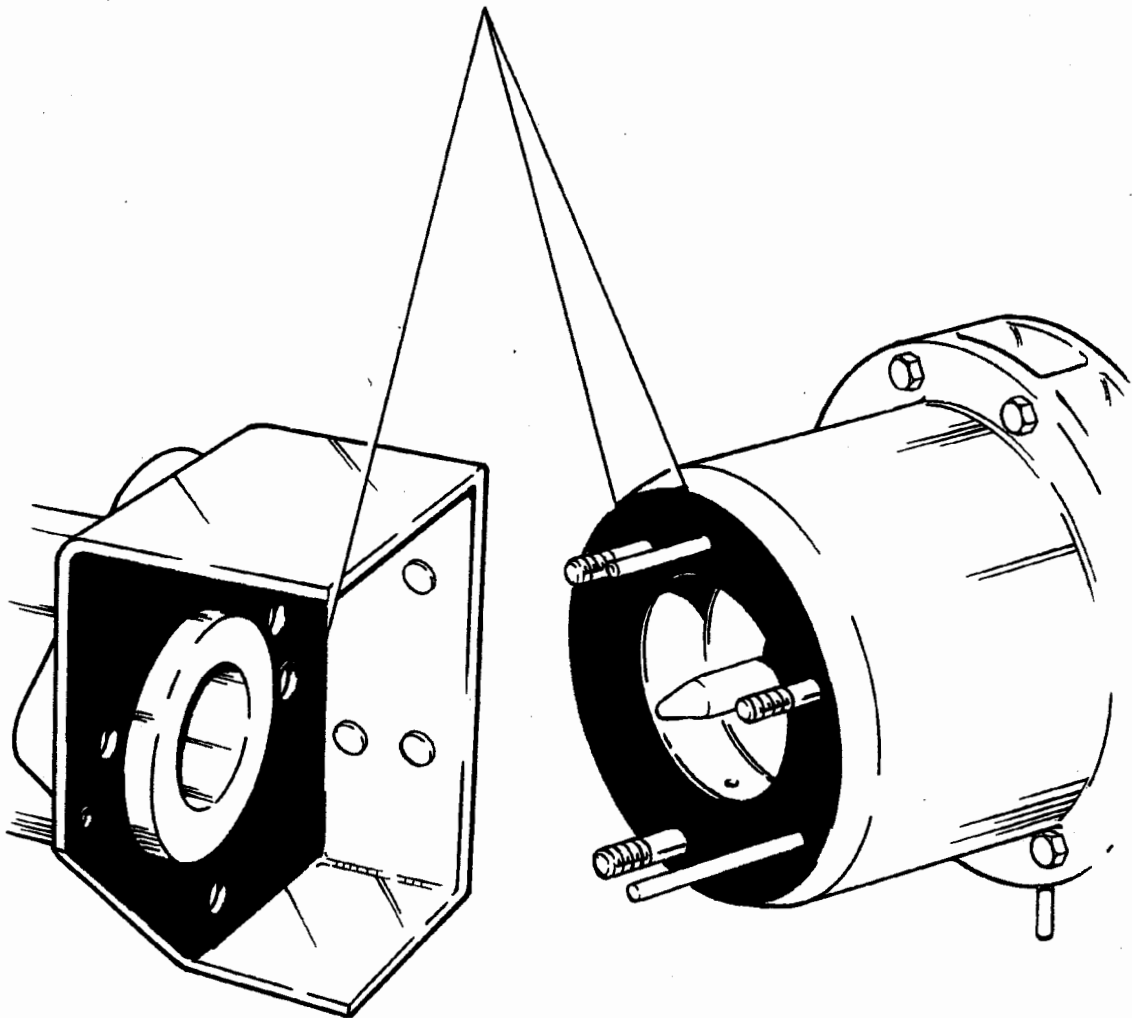

13. While EC-750-C is still tacky, refit actuator assembly to bracket and master cylinder. Refit air lines.

 EC-750-C

TASK 16. BRAKE MASTER CYLINDER ACTUATOR (continued)

14. Fit a 2 metre length of 7/32 in. i.d. rubber tubing 6MT6 4720 99 805 7839 to breather adaptor and secure tightly with plastic cable tie 6MT4 5340 99 820 5376.

15. Brush an even coat of EC-750-C around indicator rod and onto bracket; around breather adaptor actuator and onto actuator body.

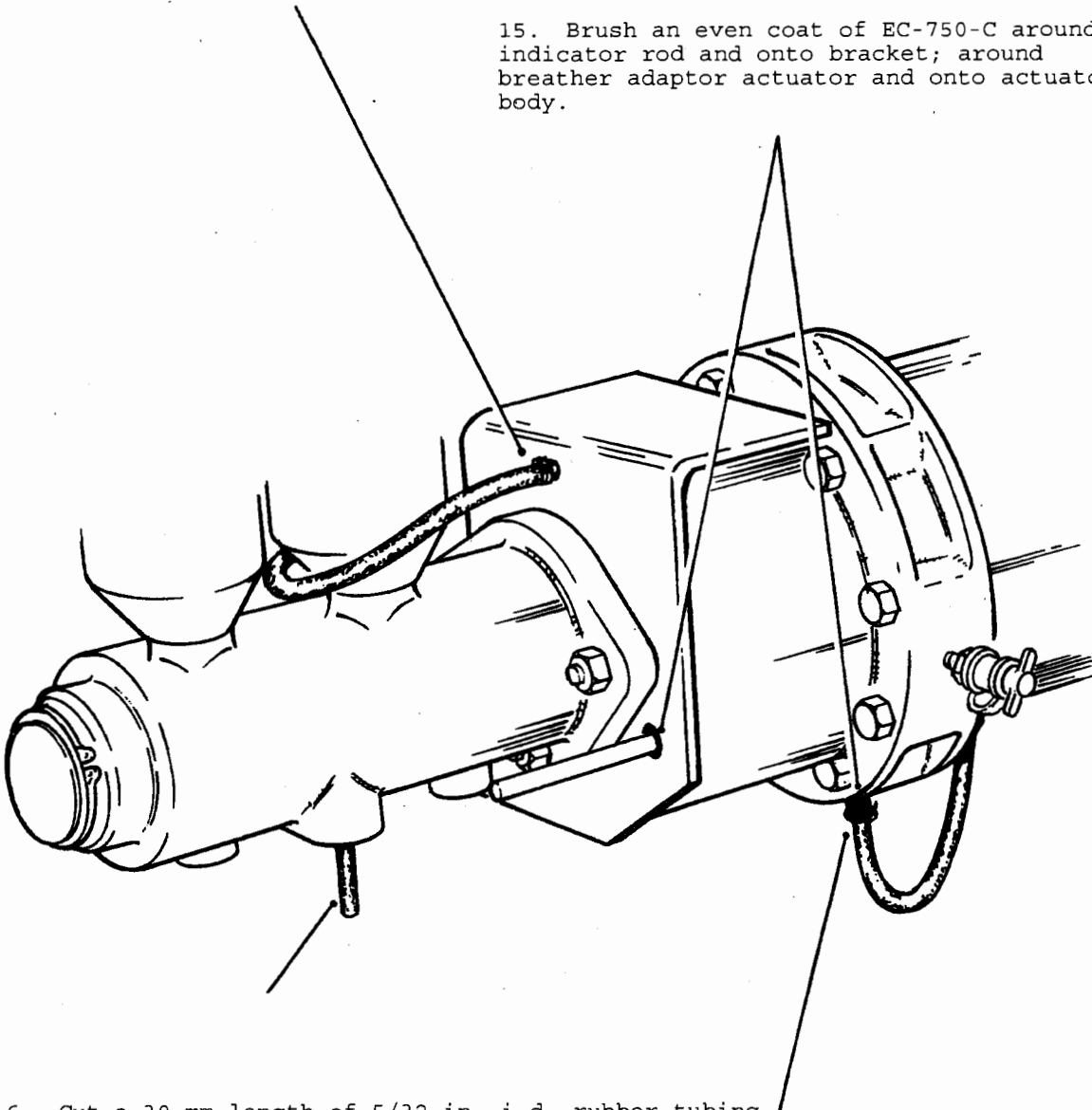

16. Cut a 30 mm length of 5/32 in. i.d. rubber tubing 6MT6 4720 99 805 7764 and fit to brake master cylinder vent leakage pipe.

17. Fit a 2 metre length of 7/32 in. i.d. rubber tubing 6MT6 4720 99 805 7839 to breather adaptor and secure tightly with a plastic cable tie 6MT4 5340 99 820 5371.

18. Pass breather hoses through two holes in chassis above rear spring hanger bracket of front R.H. spring. Coil remaining lengths and stow in a convenient position. Breather hoses will be secured in their final position at a later stage. (Task 35).

EC-750-C

TASK 17. STOP LAMP SWITCHES (2)

Note ...

Both switches are located on outside of chassis, behind R.H. front wing.

1. Remove metal protective cover. Remove rubber covers from stop lamp switches.
2. Brush an even coat of EC-750-C over top of switches, terminal covers, lead entry to terminal covers and for 12 mm along each lead.

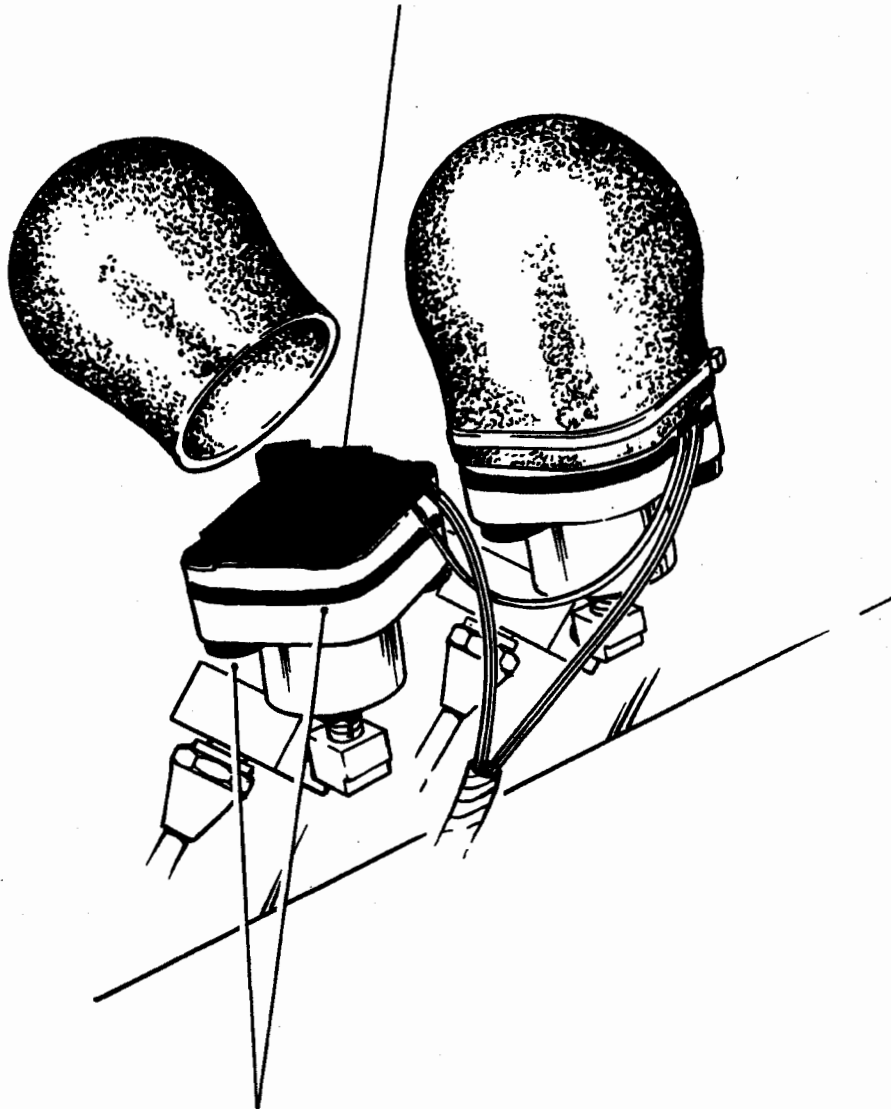

3. Brush an even coat of EC-750-C around switch joints and the base of screws.
4. Refit rubber covers and metal protective cover.

 EC-750-C

TASK 18. RUBBER ELBOW CONNECTIONS

THIS TASK TO BE CARRIED OUT WITH THE ASSISTANCE OF A VEHICLE MECHANIC

1. Check serviceability of rubber elbow and that hose clamps are secure on compressor inlet.

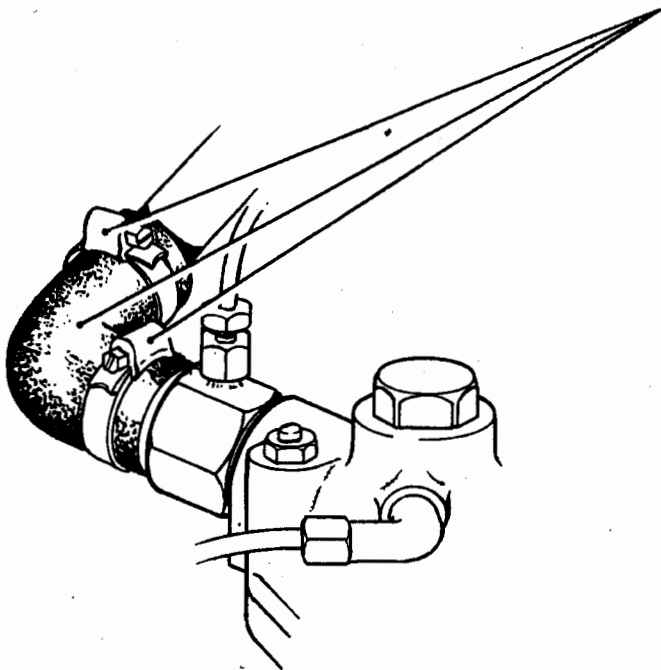

2. Check serviceability of rubber elbow on inlet manifold to compressor inlet and that hose clamps are secure.

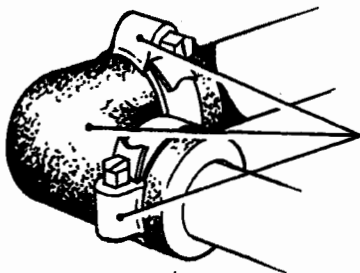
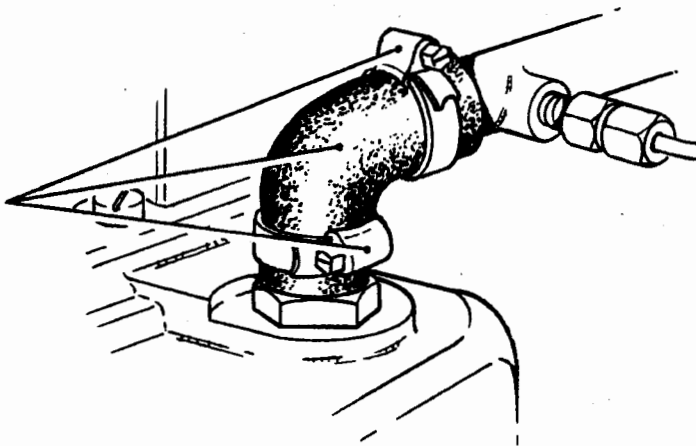

3. If fitted, check serviceability of rubber elbow on crankcase breather pipe located to rear R.H. of rocker box, and that hose clamps are secure.

Note ...

If rubber elbows in paras 1, 2 and 3 are in any way suspect or damaged, they must be replaced with new ones.

TASK 19. ENGINE CRANKCASE BREATHER (EARLIER TYPE VEHICLE)

THIS TASK TO BE CARRIED OUT WITH THE ASSISTANCE OF A VEHICLE MECHANIC.

Note ...

On later type vehicles, the engine crankcase breather is blanked off. Select Task 19 or 20 according to type.

1. Remove engine crankcase breather pipe. Stow in a safe place in the vehicle. Refit bolt removed from crankcase breather pipe bracket.

2. Check serviceability of rubber elbow and that hose clamps are secure.

3. Remove bottom bolt on bracket.

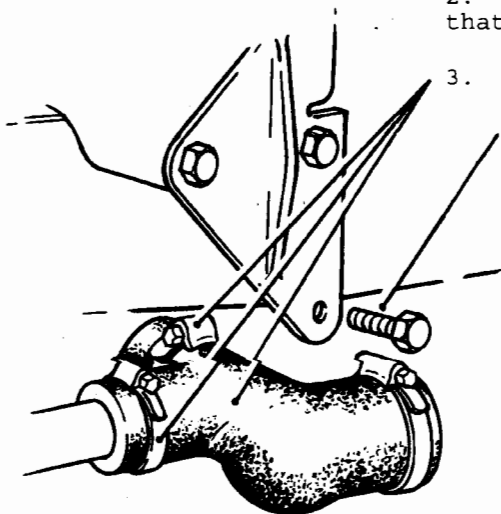

4. Fit crankcase breather adaptor 6WPG 2990 99 730 0610 (WPG 9373). Refit bolt previously removed, tighten hose clamp.

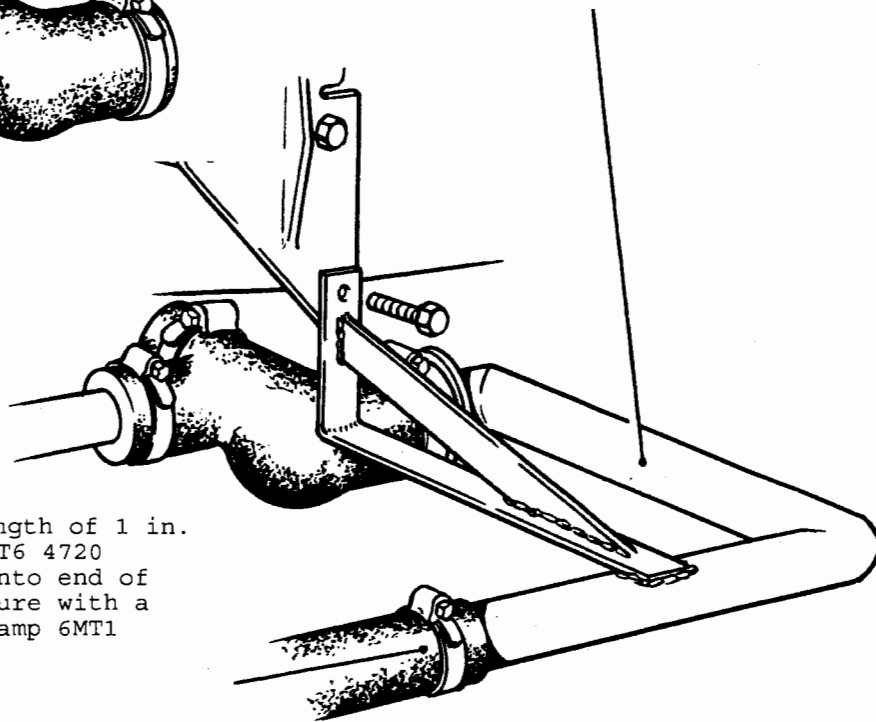

5. Fit an 800 mm length of 1 in. i.d. rubber tubing 6MT6 4720 99 805 7729 and fit onto end of breather adaptor. Secure with a 27 mm - 40 mm hose clamp 6MT1 4730 99 533 2963.

Note ...

- (1) Rubber tubing will be secured in its final position at a later stage (Task 35).
- (2) If crankcase breather elbow is in any way damaged, a new one must be fitted.

TASK 20. ENGINE CRANKCASE BREATHER (LATER TYPE VEHICLE)

THIS TASK TO BE CARRIED OUT WITH THE ASSISTANCE OF A VEHICLE MECHANIC.

1. Check serviceability of crankcase breather blanking cap and that hose clamp is secure.

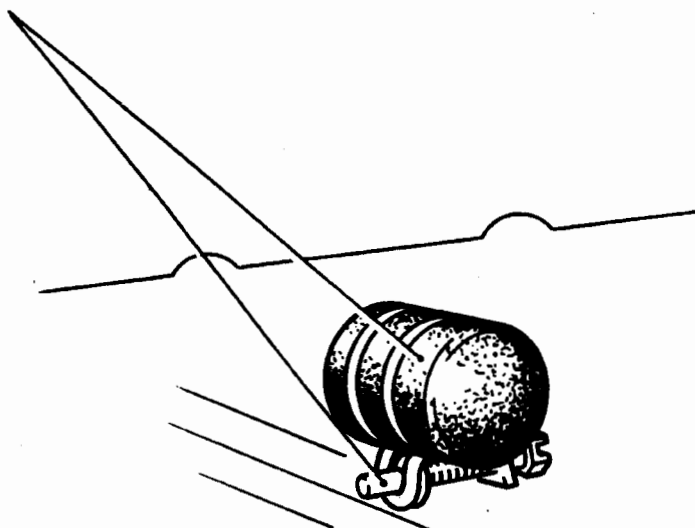

Note ...

If crankcase breather blanking cap is in any way suspect or damaged, a new one must be fitted.

TASK 21. ENGINE OIL FILLER CAP AND BREATHER (EARLIER TYPE VEHICLE)

THIS TASK TO BE CARRIED OUT WITH THE ASSISTANCE OF A VEHICLE MECHANIC.

Note ...

One of two alternative types of engine filler cap breather are fitted. Select Task 21 or 22 according to type.

1. Remove oil filler cap. Thoroughly clean and degrease cap.
2. Apply an even coat of Bostik 1GA 186 to cap washer and over one face of rubber washer 6WPG 5330 99 823 9609 (WPG 9227). When adhesive is tacky to the touch, insert rubber washer into cap pressing adhesive faces together.

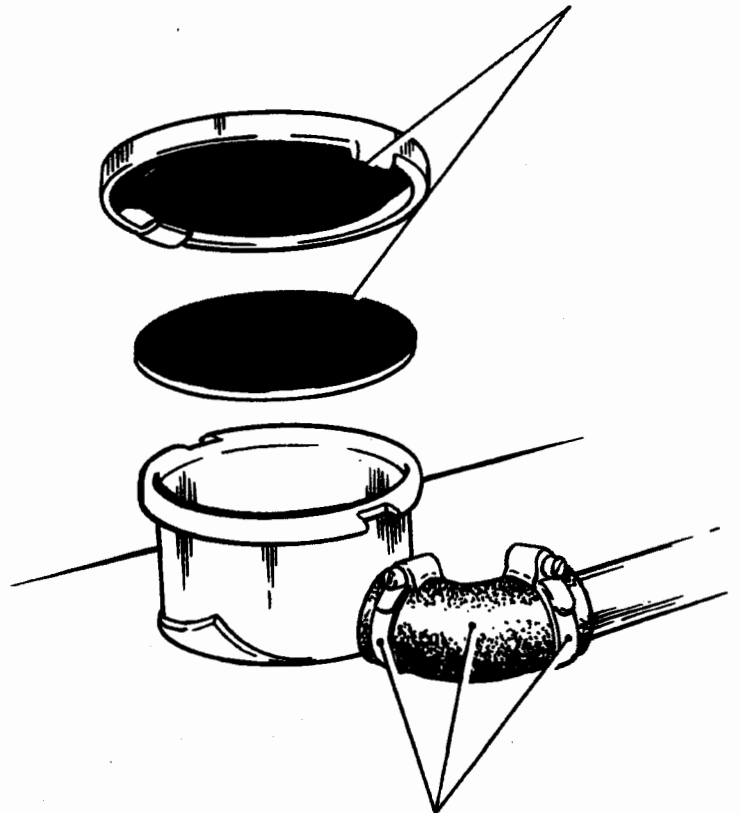

3. Refit and tighten cap.
4. check serviceability of rubber elbow and that hose clamps are secure.

Note ...

If rubber elbow is in any way suspect or damaged, a new one MUST be fitted.

 Bostik 1GA 186

TASK 22. ENGINE OIL FILLER CAP AND BREATHER (LATER TYPE VEHICLE)

THIS TASK TO BE CARRIED OUT WITH THE ASSISTANCE OF A VEHICLE MECHANIC.

1. Remove oil filler cap. Thoroughly clean and degrease cap.
2. Apply an even coat of Bostik 1GA 186 to cap washer and over face of rubber washer 6WPG 5330 99 823 9609 (WPG 9227). When adhesive is tacky to the touch insert rubber washer into cap pressing adhesive faces together.

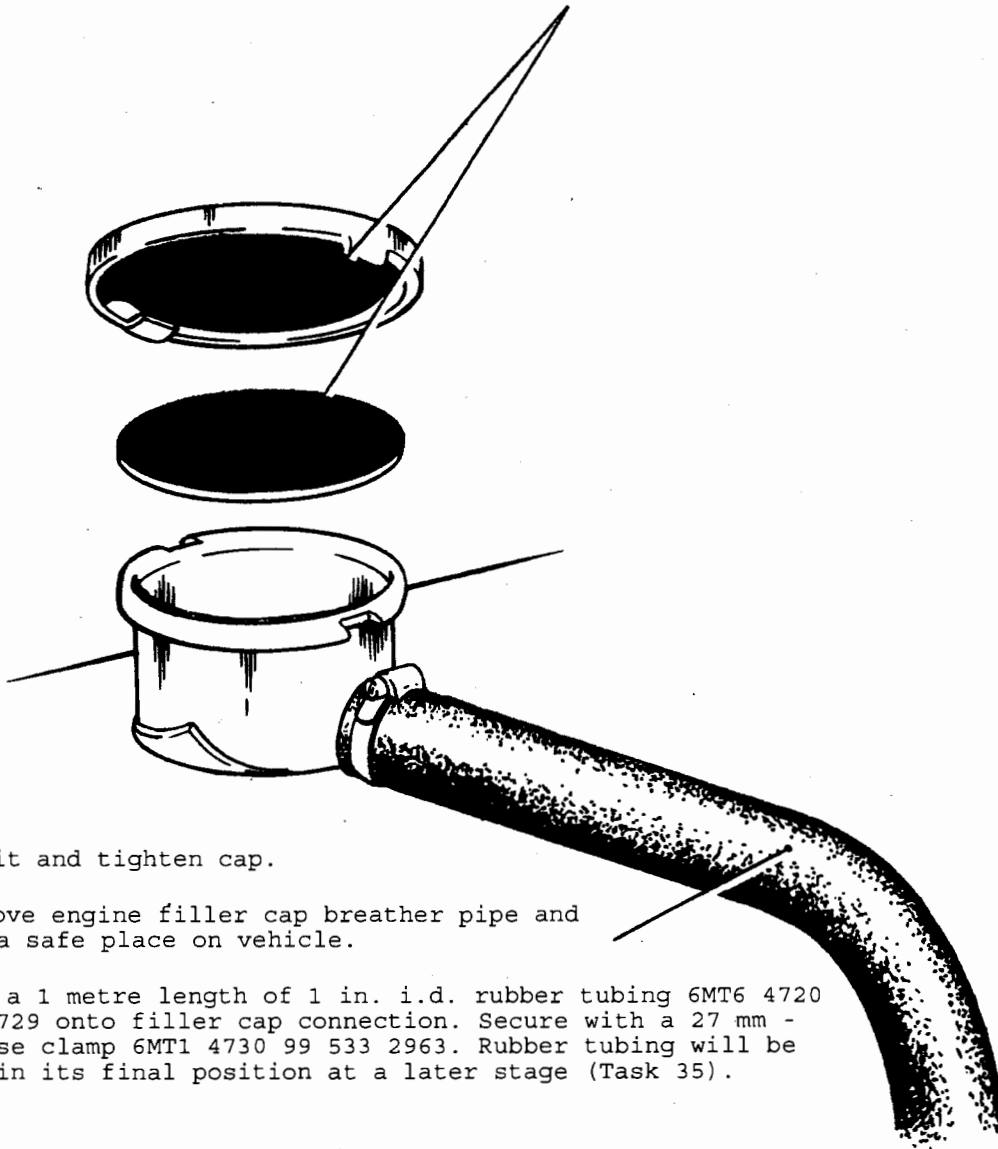

3. Refit and tighten cap.
4. Remove engine filler cap breather pipe and stow in a safe place on vehicle.
5. Fit a 1 metre length of 1 in. i.d. rubber tubing 6MT6 4720 99 805 7729 onto filler cap connection. Secure with a 27 mm - 40 mm hose clamp 6MT1 4730 99 533 2963. Rubber tubing will be secured in its final position at a later stage (Task 35).

 Bostik 1GA 186

TASK 23. ENGINE OIL DIPSTICK (EARLY TYPE VEHICLES)

Note ...

One of two alternative types of dipstick are fitted. Select Task 23 or 24 according to type.

1. Remove dipstick.
2. Cut a 25 mm length of a 1/4 in. dia. non-return valve 6WPG 2540 99 817 9523, (WPG 9138).

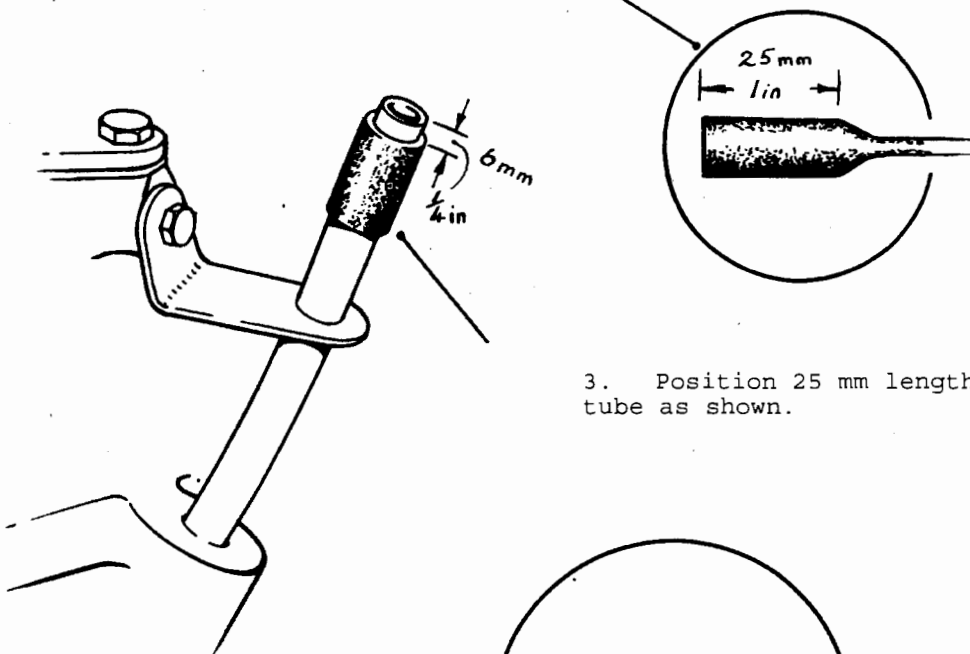

3. Position 25 mm length over dipstick tube as shown.

4. Cut a 32 mm length off a 3/8 in. dia. non-return valve 6WPG 2540 99 816 2506 (WPG 9123).

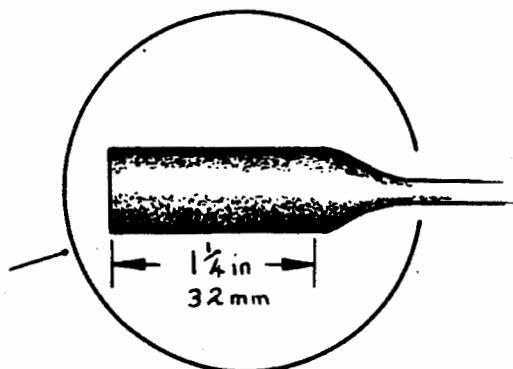

5. Position 32 mm length on dipstick as shown.
6. Refit dipstick into dipstick tube so that rubber tubes overlap.

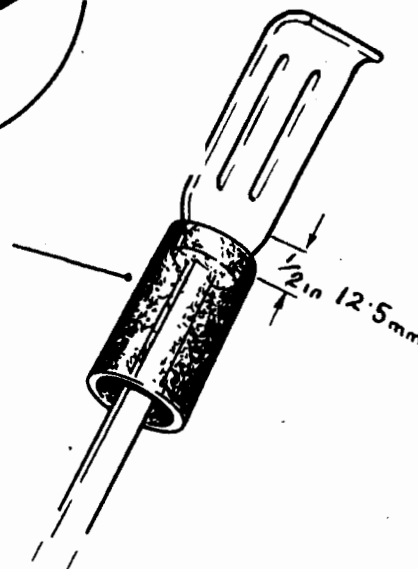

TASK 24. ENGINE OIL DIPSTICK (LATER TYPE VEHICLE)

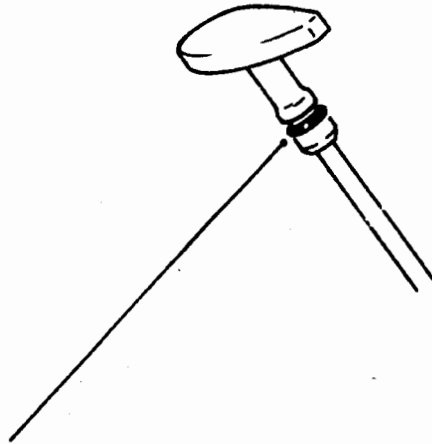

1. Check condition of 'O' ring on engine dipstick.

Note ...

If dipstick 'O' ring is in any way damaged, a new one must be fitted.

TASK 25. COLD START SOLENOID AND HEATER PLUGS (2)

Note ...

The cold start solenoid is mounted on a bracket bolted to the engine inlet manifold. The heater plugs (2) are fitted fore and aft in the turbocharger to inlet manifold induction pipe.

2. Brush an even coat of EC-750-C over heater plug hexagon, ring nut and screw-thread, over connectors and for 12 mm along cable length. Apply a second coat after first coat has dried.

3. Repeat para 1 for the second heater plug.

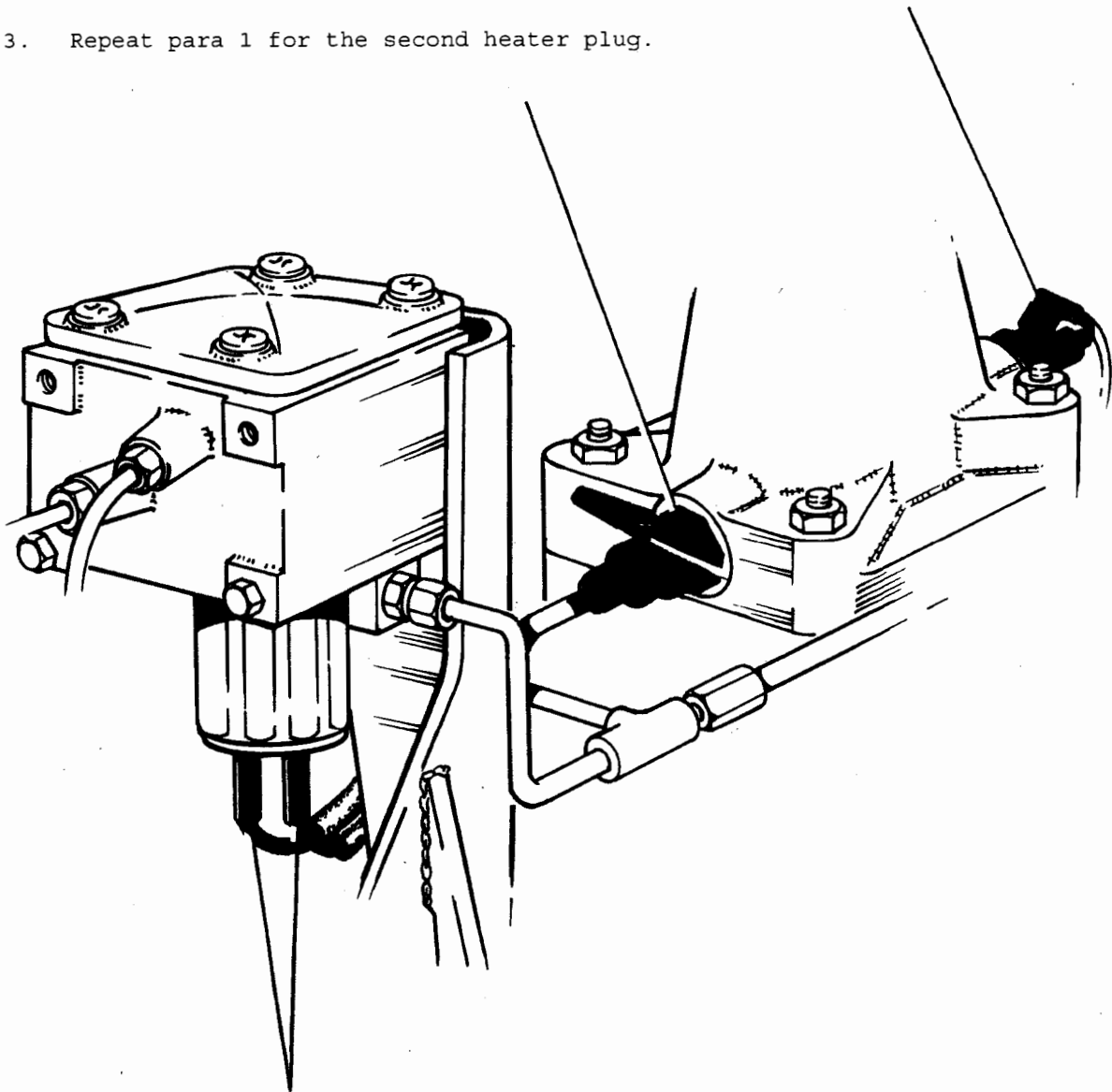

4. Brush an even coat of EC-750-C over end of the cold start solenoid, over cable entry and for 25 mm along cable length. Apply a second coat after first has dried.

 EC-750-C

TASK 26. FUEL LIFT PUMP

1. Apply an even coat of GREASE over each end of priming lever spindle.

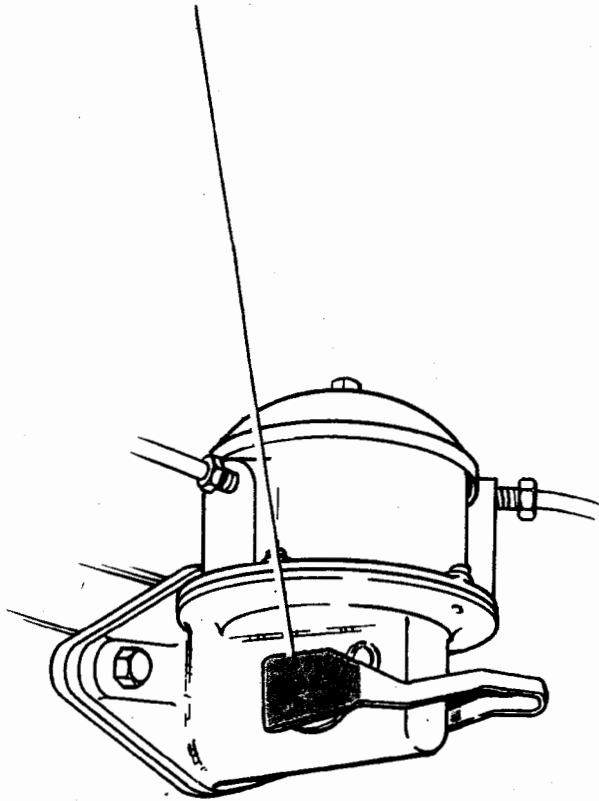

 Grease

TASK 27. TACHOMETER

THIS TASK TO BE CARRIED OUT WITH THE ASSISTANCE OF A VEHICLE MECHANIC.

1. Disconnect tachometer cable and light holder from tachometer head. Remove tachometer bracket with tachometer from dash; refit bracket bolts in dash.
2. Drill one 24 mm dia. hole and two 6.5 mm dia. holes to dimensions shown. Dimensions are taken from edges of indentations in dash and are in mm.

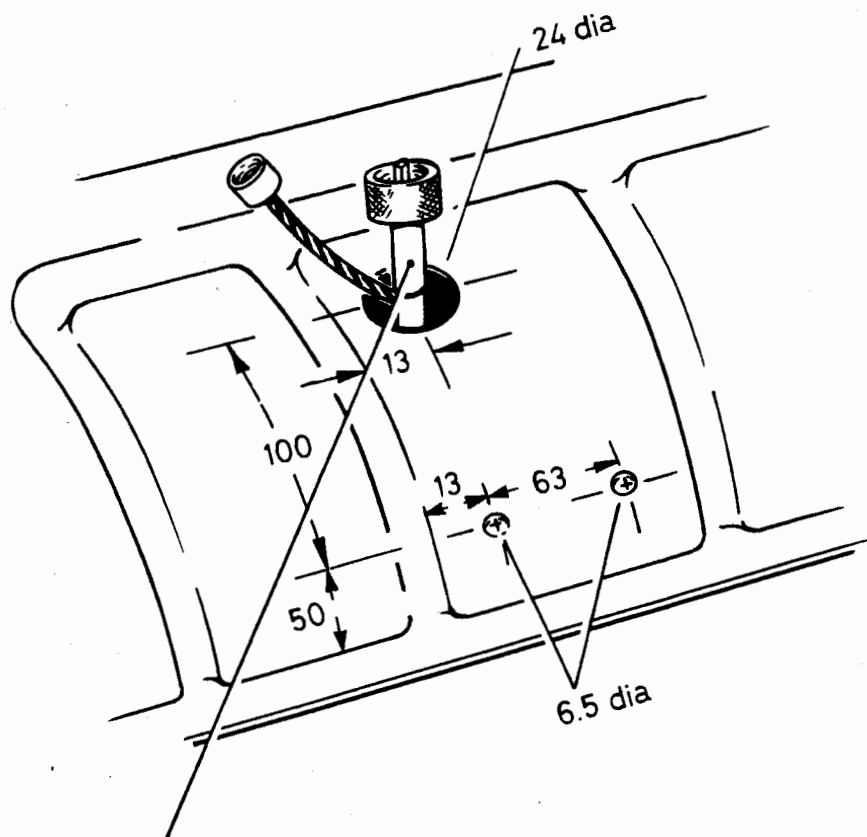

3. Pass tachometer cable and light holder lead through large hole.

TASK 27. TACHOMETER (continued)

4. Fit bracket 6WPG 2540 99 823 9608 (WPG 9226) to dash panel using two 6 mm dia. screws, washers and nuts provided in kit.

5. Reconnect tacho cable and lighting holder/lead.

6. Cut rubber grommet H9 5325 99 942 6849 and fit over tachometer cable and light holder lead; fit grommet into drilled hole.

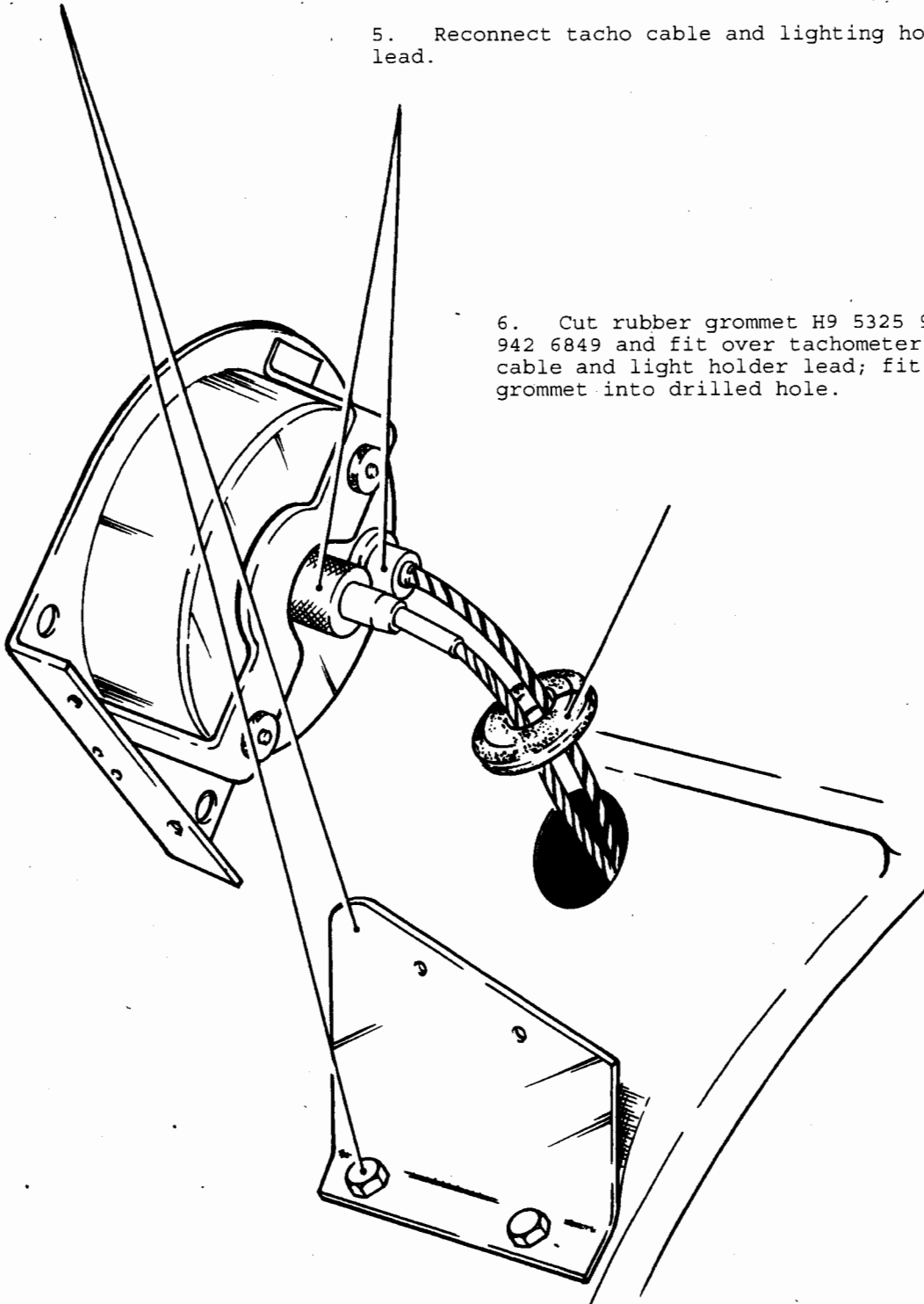

TASK 27. TACHOMETER (continued)

7. Fit tacho bracket with head to bracket previously fitted to dash (para 4) using 6 mm dia. screws, washers and nuts provided in kit.

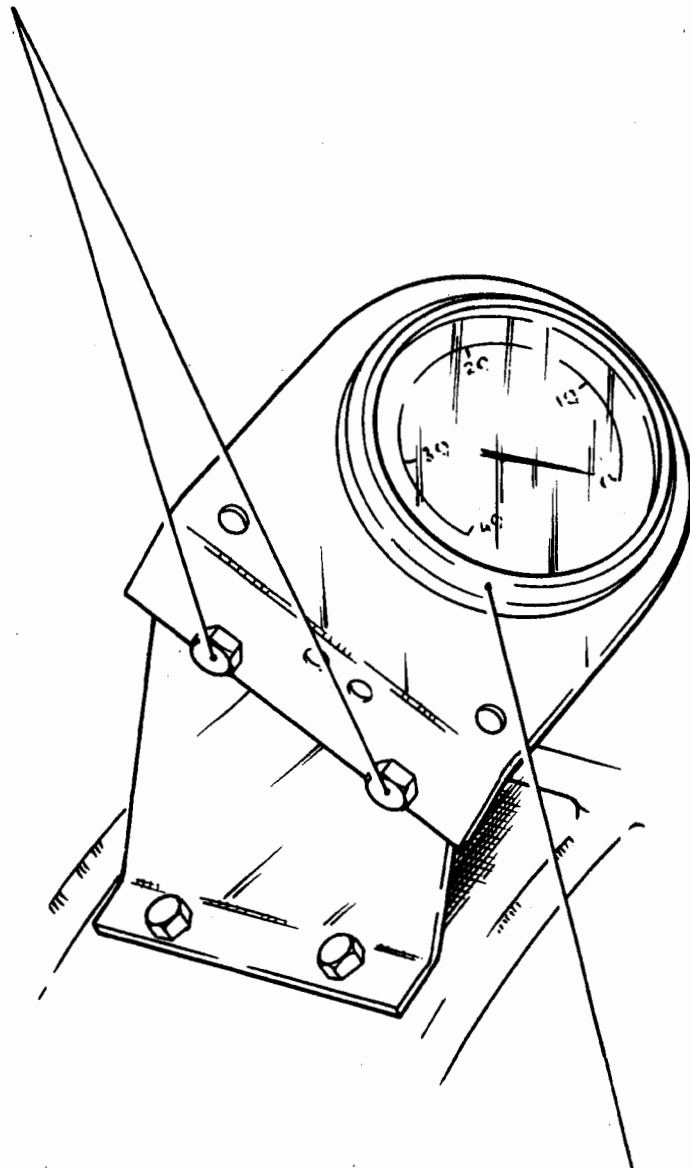

8. Slacken tacho head clamp and adjust head so that figures on tacho dial are readable from the driver's seat. Tighten clamp screws.

TASK 28. TRAILER BRAKE EMERGENCY SWITCH, (EARLY TYPE VEHICLE)

THIS TASK TO BE CARRIED OUT WITH THE ASSISTANCE OF A VEHICLE MECHANIC.

Note ...

One of two alternative types of trailer brake switch are fitted. Select Task 28 or 29 according to type.

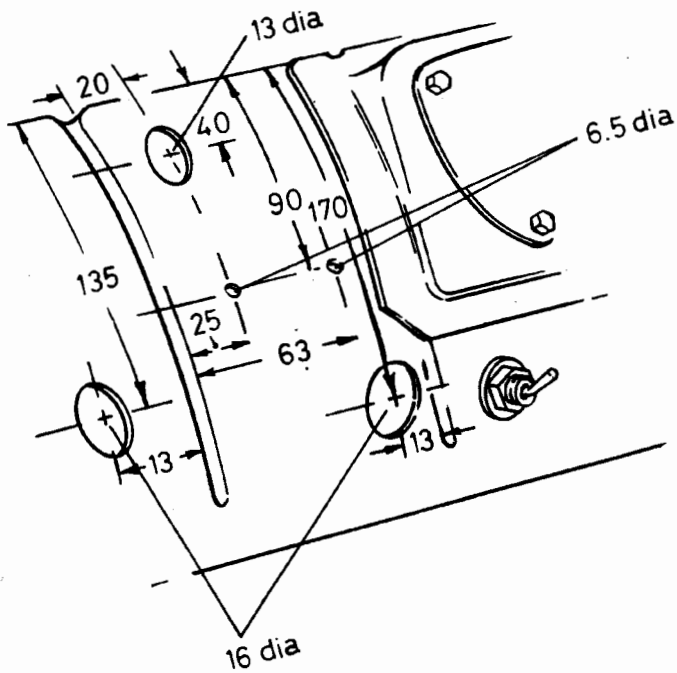

1. Drill dash panel to the dimensions and hole sizes shown. Dimensions are taken from edges of indentations in dash and are in mm.

2. Fit bracket 6WPG 2990 99 730 0609 (WPG 9375) to dash panel using nuts and washers provided with bracket.

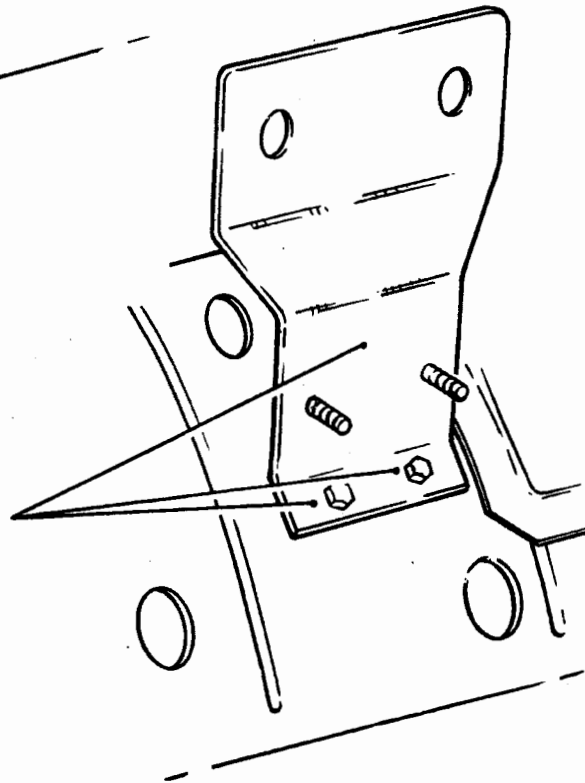

TASK 28. TRAILER BRAKE EMERGENCY SWITCH, (EARLY TYPE VEHICLE continued)

3. Disconnect air pipes and electrical leads from switch.

Note ...

Before disconnection identify positions for correct refitting.

4. Remove bracket complete with switch from dash. Refit existing bolts back into dash.

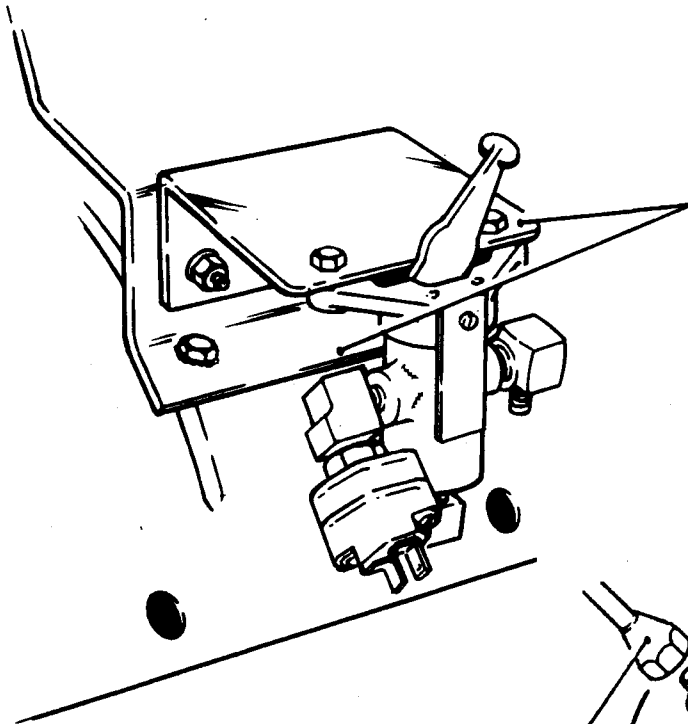

5. Fit the switch and bracket to the bracket mounted on the dash in para 2.

6. Connect extension air pipe 6WPG 4710 99 087 0514 (WPG 9383) to the orange air pipe that passes through the cab floor.

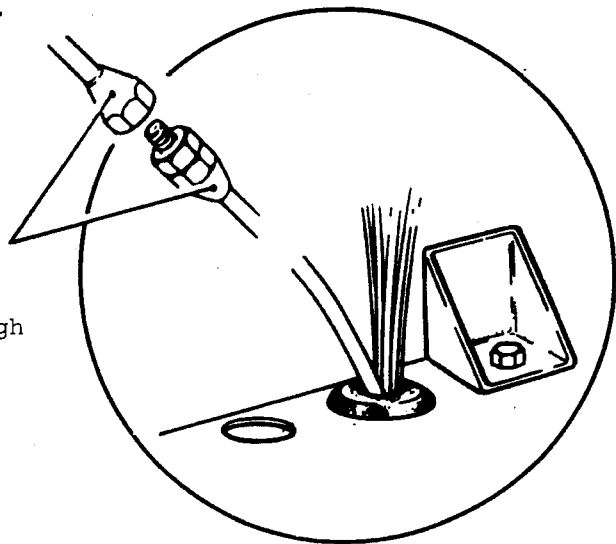

TASK 28. TRAILER BRAKE EMERGENCY SWITCH, (EARLY TYPE VEHICLE continued)

7. Pass extension pipe through R.H. lower hole in dash and fit rubber grommet H9 5325 99 942 6842 over pipe. Fit grommet into hole in dash and connect extension pipe to switch.

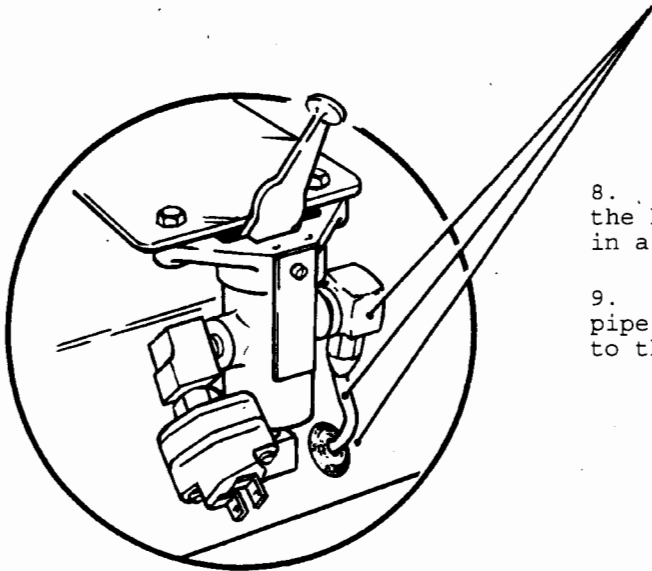

8. Remove remaining air pipe from the hill holder control valve. Stow in a safe place in the vehicle.

9. Connect replacement extension pipe 6WPG 4710 99 852 8280 (WPG 9482) to the hill holder control valve.

10. Pass extension pipe together with electrical extension lead 6WPG 2990 99 730 9549 (WPG 9372), through L.H. lower hole in dash. Fit a rubber grommet H9 5325 99 942 6842 over pipe and lead. Fit grommet into hole in dash. Connect extension lead and extension pipe to switch.

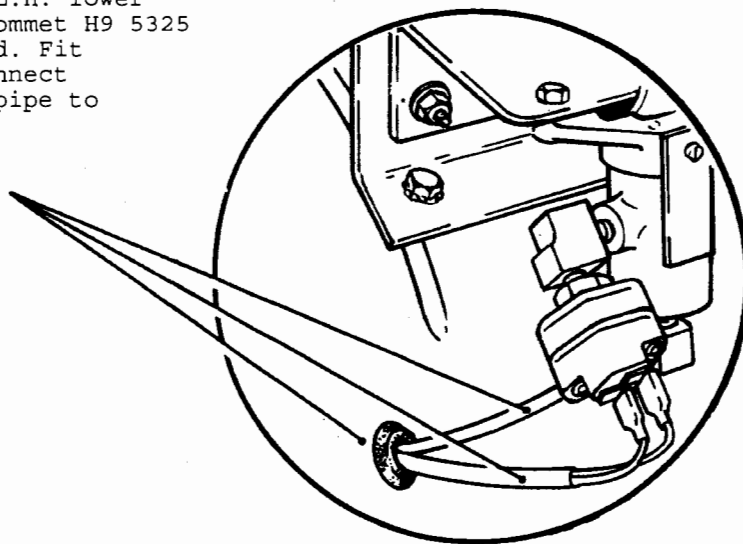

11. Connect remaining free ends of electrical extension lead to original switch wiring.

TASK 29. TRAILER BRAKE EMERGENCY SWITCH, (LATER TYPE VEHICLE)

THIS TASK TO BE CARRIED OUT WITH THE ASSISTANCE OF A VEHICLE MECHANIC.

1. Drill dash panel to the dimensions and hole sizes shown. Dimensions are taken from edges of indentations in dash and are in mm.

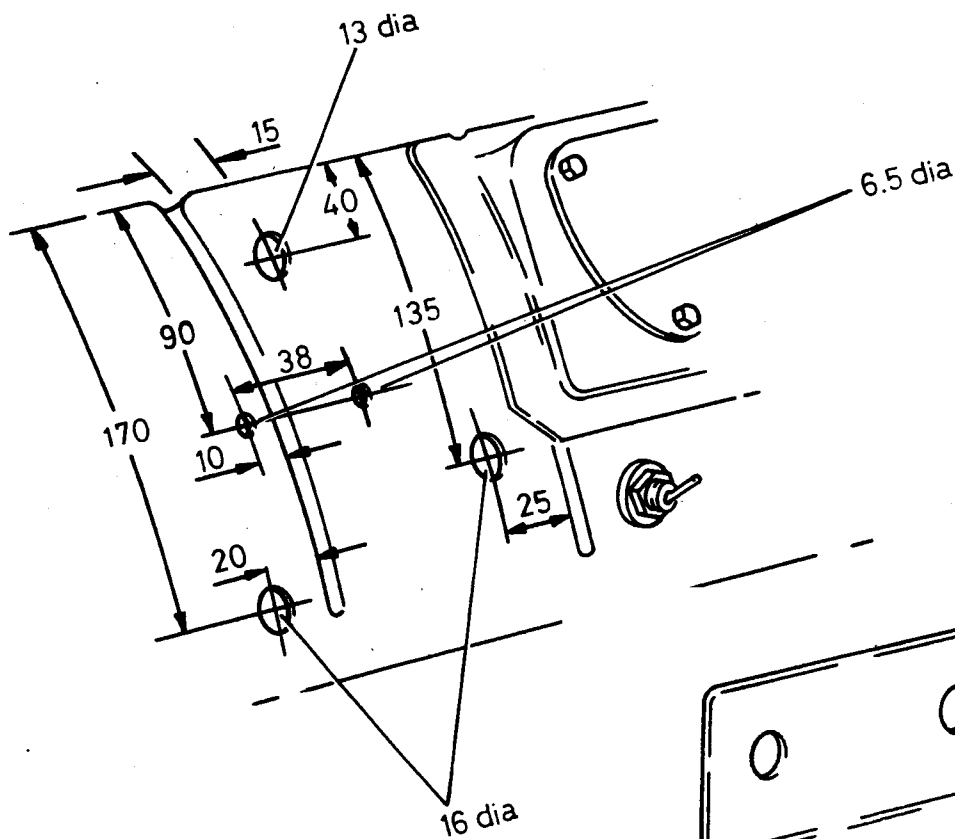

2. Fit bracket 6WPG 2990 99 730 0609 (WPG 9375) to dash panel using nuts and washers provided with bracket.

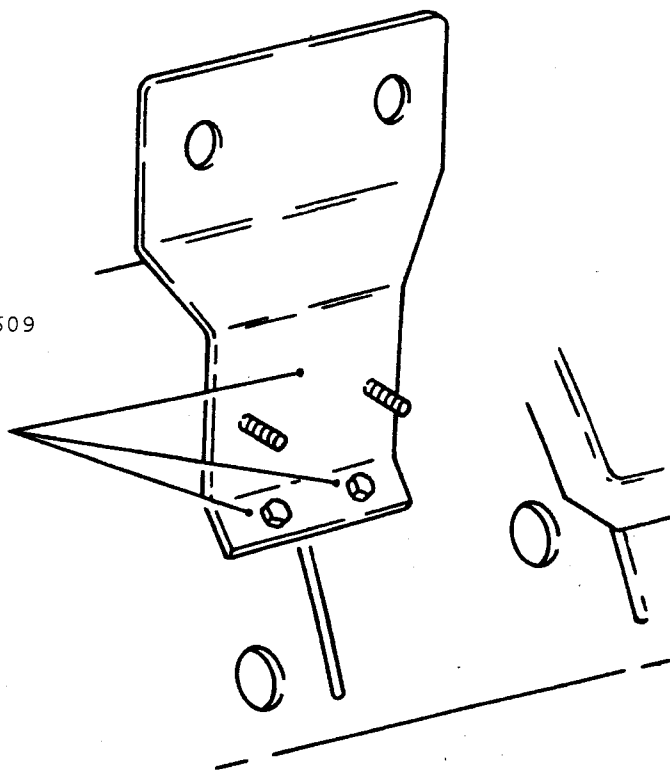

TASK 29. TRAILER BRAKE EMERGENCY SWITCH, (LATER TYPE VEHICLE continued)

3. Disconnect air pipes and electrical leads from switch.

Note ...

Before disconnection, identify positions for correct refitting.

4. Remove bracket complete with switch from dash. Refit existing bolts back into dash.

5. Fit the switch and bracket to the bracket mounted on the dash in para 2.

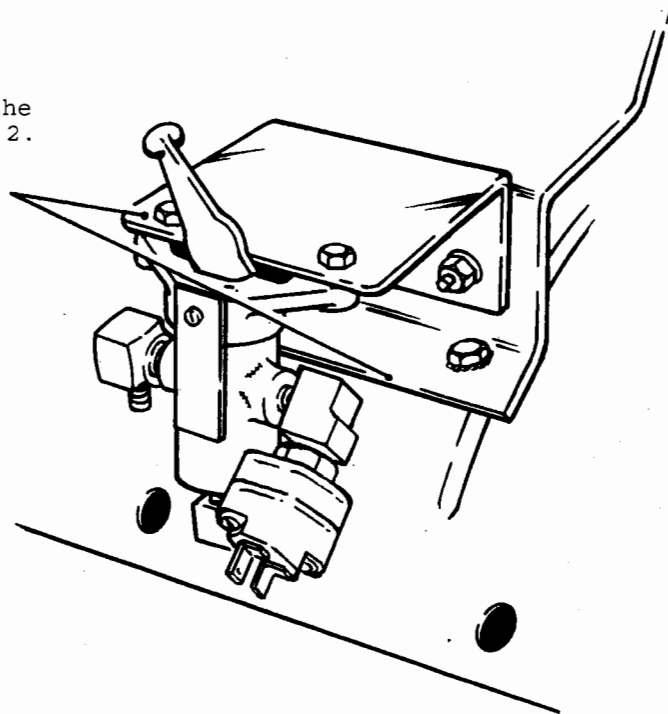
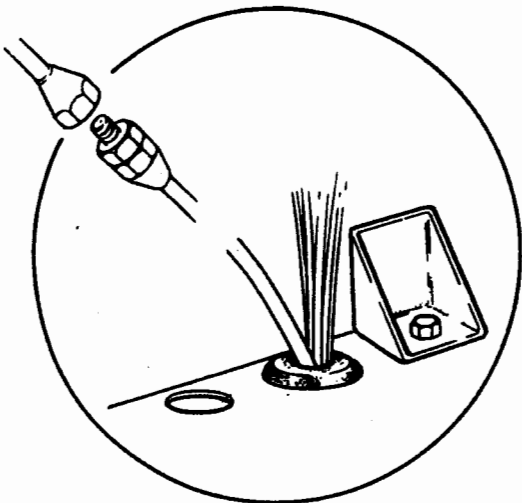

6. Connect extension air pipe 6WPG 4710 99 087 0514 (WPG 9383) to the orange air pipe that passes through the cab floor.

TASK 29. TRAILER BRAKE EMERGENCY SWITCH, (LATER TYPE VEHICLE continued)

7. Pass extension pipe through L.H. lower hole in dash and fit rubber grommet H9 5325 99 942 6842 over pipe. Fit grommet into hole in dash and connect extension pipe to switch.

8. Remove the remaining air pipe from the hill holder control valve. Stow in a safe place in the vehicle.

9. Connect replacement extension pipe 6WPG 4710 99 852 8280 (WPG 9482) to the hill holder control valve.

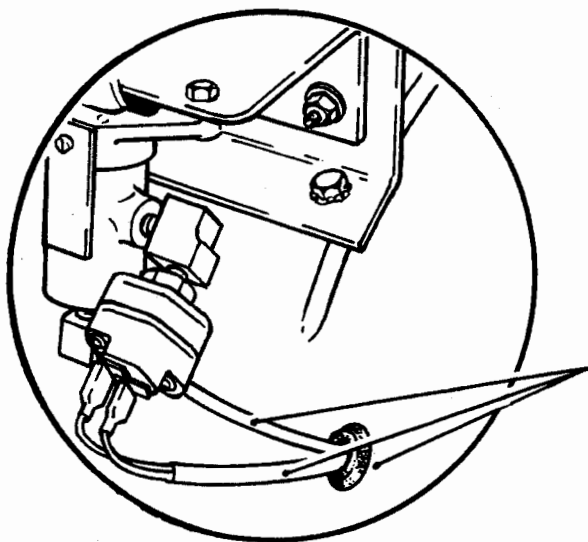
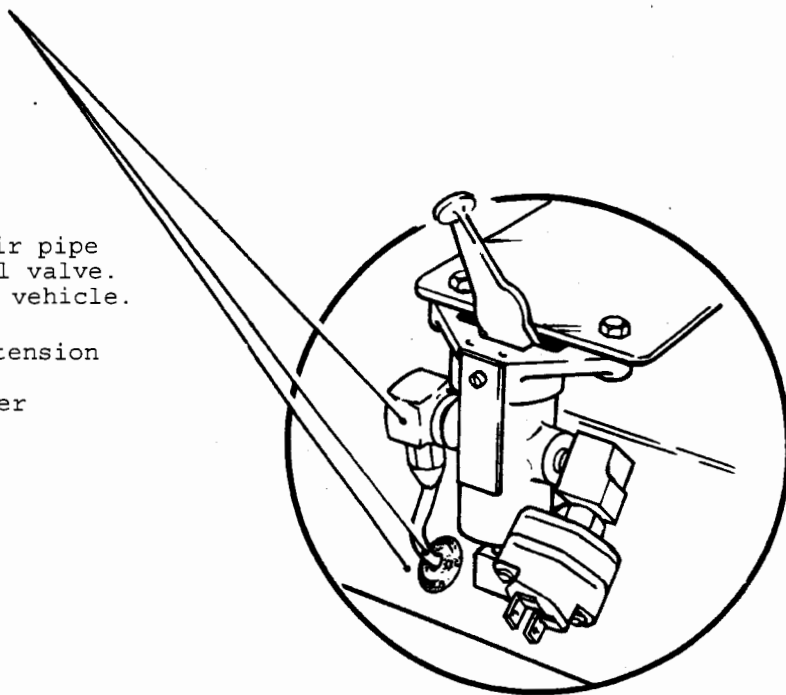

10. Pass extension pipe together with electrical extension lead 6WPG 2990 99 730 9549 (WPG 9372) through R.H. lower hole in dash. Fit a rubber grommet H9 5325 99 942 6842 over pipe and lead. Fit grommet into hole in dash. Connect extension lead and extension pipe to switch.

11. Connect remaining free ends of electrical extension lead to original switch wiring.

TASK 30. AND BRAKE LEVER INDENTATION

THIS TASK TO BE CARRIED OUT WITH THE ASSISTANCE OF A VEHICLE MECHANIC.

1. Illustration shows indentation on underside of wing and drilling is to allow for draining of water.

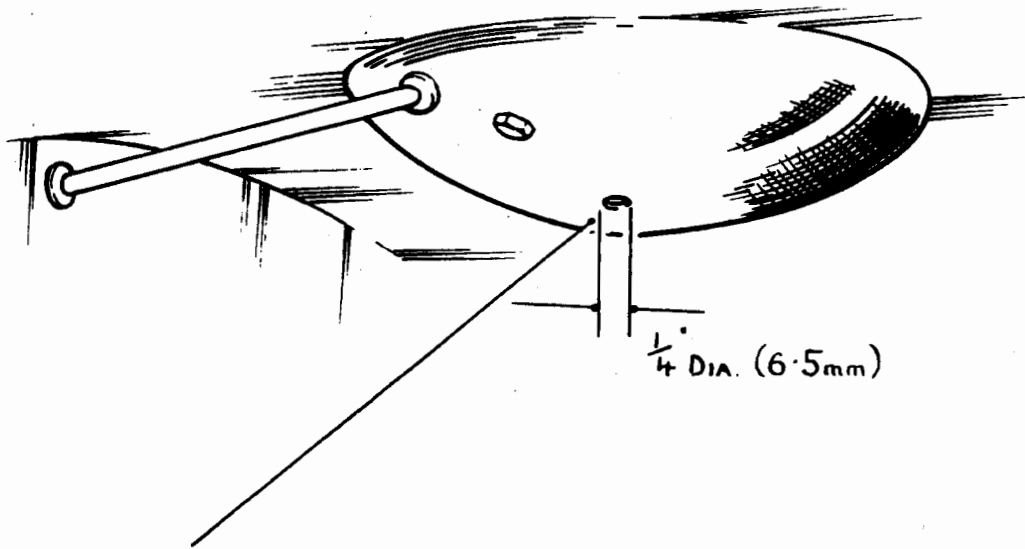

2. Drill a 6.5 mm dia. hole from underside of wing at lowest point of indentation.

TASK 31. THERMOSTART RELAY, CIRCUIT BREAKER, BALLAST RESISTOR

THIS TASK TO BE CARRIED OUT WITH THE ASSISTANCE OF A VEHICLE MECHANIC.

Notes...

- (1) Thermostart relay, circuit breaker and ballast resistor are located beneath the cab, mounted on the cab back panel.
- (2) Before removal or disconnection, identify the positions of leads for correct refitting.

1. Disconnect both wires on circuit breaker, Brown, Brown/Red. Disconnect both/wires on ballast resistor, Brown/Red.

2. Remove circuit breaker and ballast resistor from bulkhead.

3. Disconnect feed wire on cold start relay (small Brown/Red). Remove relay from bulkhead complete with wiring. Replace fixing screws in bulkhead.

Note ...

Do not disconnect any other leads.

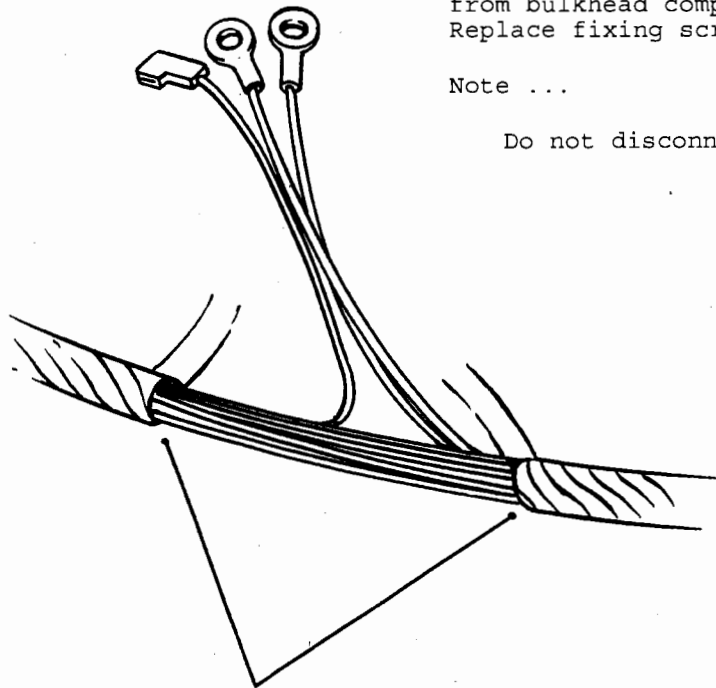

4. Cut insulation/binding back on vehicle loom approximately 125 - 150 mm.

TASK 31. THERMOSTART RELAY, CIRCUIT BREAKER, BALLAST RESISTOR (continued)

5. Fit circuit breaker, ballast resistor and relay into box Cold Start 6WPG 2990 99 730 9551 (WPG 9370) as shown. Reconnect all internal wires. Make sure that earth lead has a good clean contact to box and box to vehicle bulkhead.

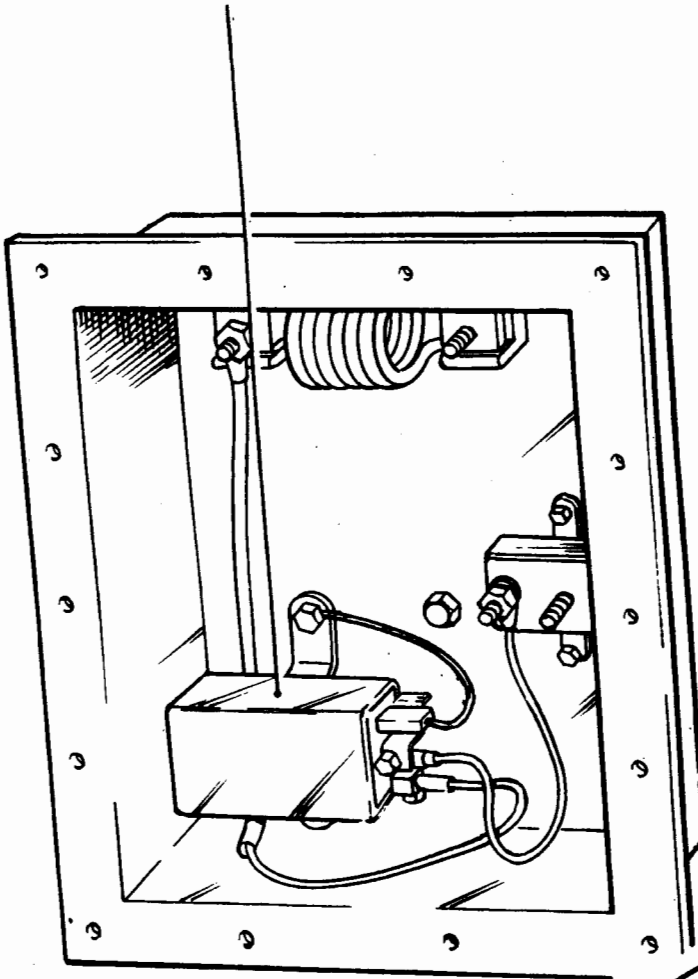

6. Fix box to bulkhead using square holes already in bulkhead.

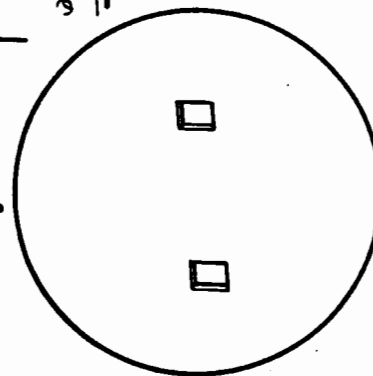

Note...

A nut followed by a washer is fitted on box mounting bolts to act as a spacer. It is advisable to stick gasket lightly to box with Bostik 1GA 186.

TASK 31. THERMOSTART RELAY, CIRCUIT BREAKER, BALLAST RESISTOR (continued)

7. Remove heat resistant fabric covering from ballast resistor leads at the section where they pass through rubber bung. Take care not to damage the insulating cover. Allow a minimum of 110 mm of free lead from bung to terminal ends for reconnection inside box.

8. Cut three slots in rubber bung 6WPG 5325 99 822 2576 (WPG 9179) using a sharp knife. DO NOT USE A HACKSAW. Ease leads individually into slots in bung. Press down leads until they seat in holes of bung.

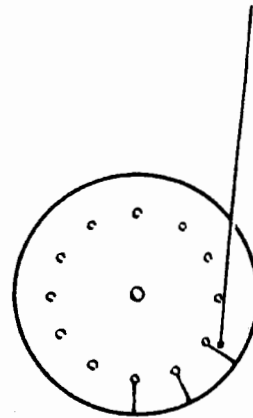
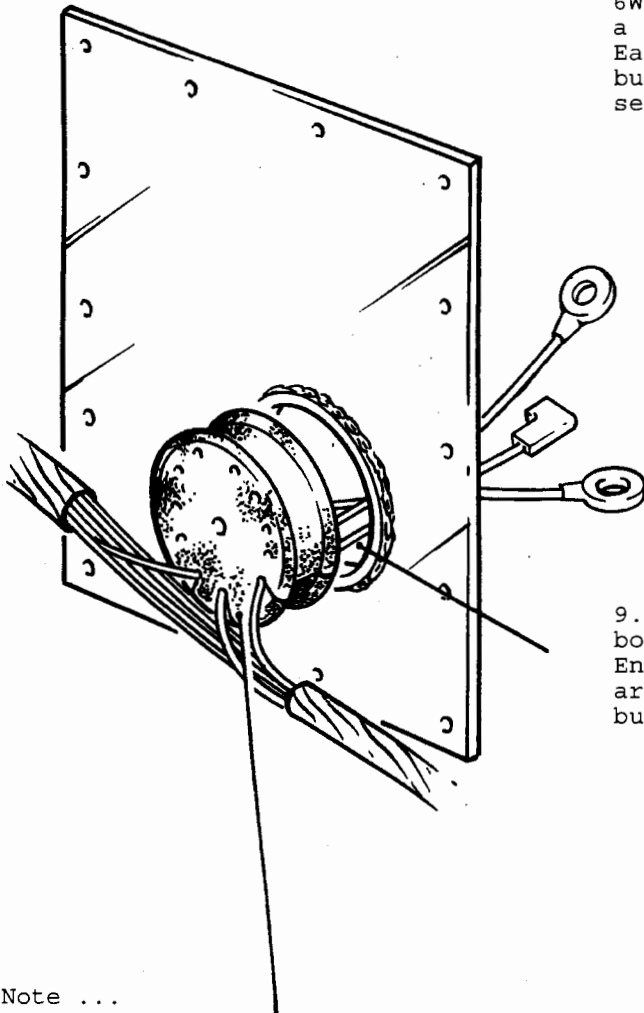

9. Pass the three leads through hole in box cover and ease bung into box lid. Ensure that circumferential lips of bung are seated flat on inside and outside of bung clamp on box lid.

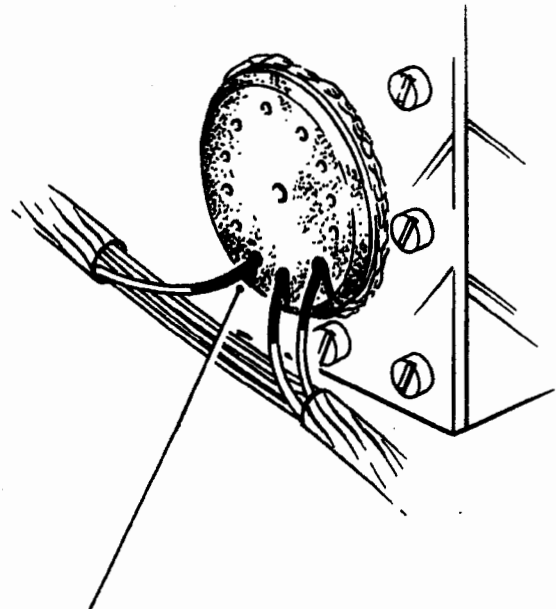

Note ...

When fitting rubber bung into box lid, ensure that lead entries are in the position shown.

10. Reconnect wiring inside box, fit box cover.

11. Brush an even coat of EC-750-C around each lead entry slot and for 25 mm along each lead length.

 EC-750-C

TASK 32. IGNITION AND THERMOSTART SWITCHES

THIS TASK TO BE CARRIED OUT WITH THE ASSISTANCE OF A VEHICLE MECHANIC.

1. Disconnect wiring plug from back of ignition switch and leads from thermostart switch (located alongside ignition switch).
2. Remove ignition and thermostart switches. Fit rubber grommets 6MT1 5325 99 818 7636 and 6MT1 5325 99 621 2514 into holes vacated by ignition and thermostart switches.
3. Refit ignition and thermostart switches into bracket (WPG 9378) previously mounted in Task 28 or 29.

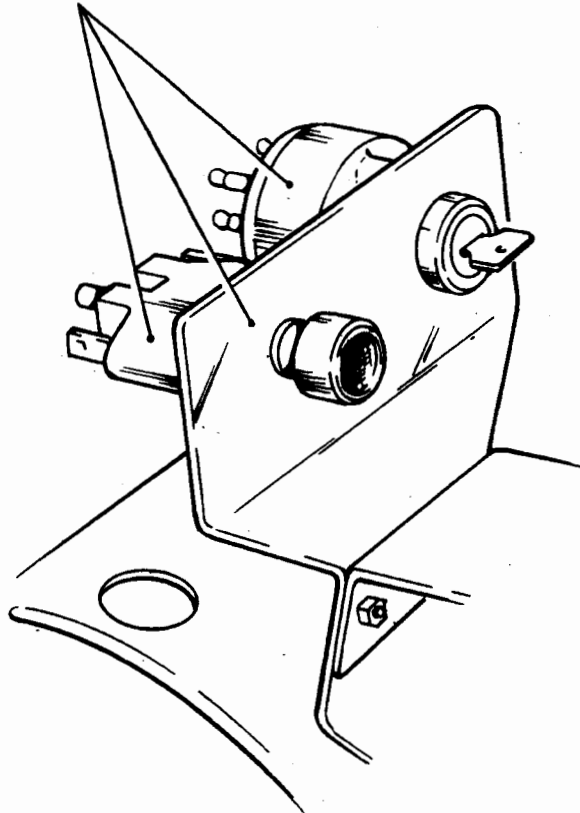

4. Remove female plug from ignition switch lead. Care must be taken when removing leads from female plug that wires are not pulled out of their terminals.
5. Remove ignition switch rubberboot from vehicle loom (lay safely to one side) and replace female plug.

TASK 32. IGNITION AND THERMOSTART SWITCHES (continued)

6. Fit rubber grommets H9 5325 99 942 3430 (2) into front cross member.

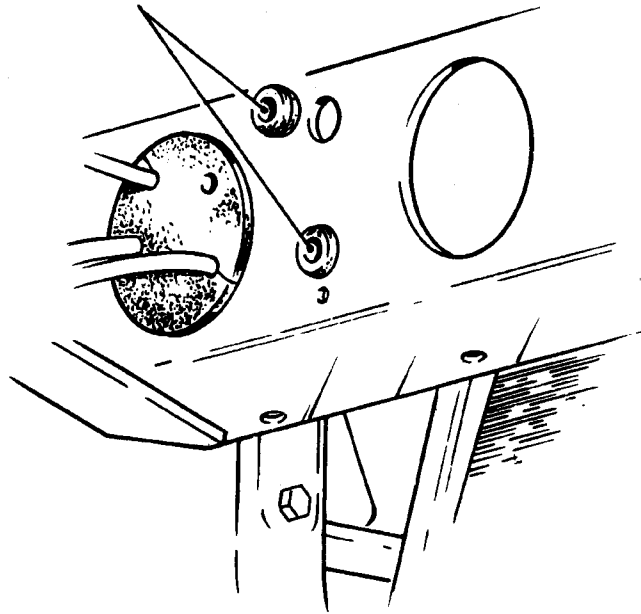

7. Pass female connector end of the thermostart switch extension lead 6WPG 2540 99 822 3033 (WPG 9191) from behind right hand radiator support bracket and through upper grommet.

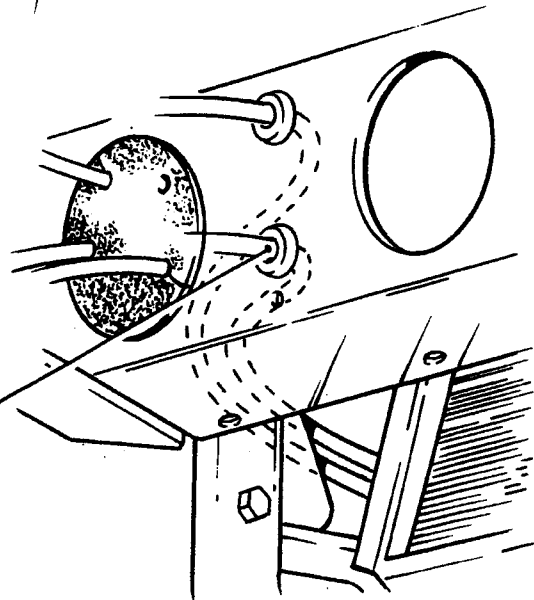

8. Remove female plug from ignition switch extension lead 6WPG 2920 99 730 9550 (WPG 9374) and pass cable ends from behind right hand radiator support bracket and through lower grommet.

TASK 32. IGNITION AND THERMOSTART SWITCHES (continued)

9. Drill one 13 mm. dia hole in position illustrated in cab floor adjacent to tachometer cable. Remove sharp edges and burrs from hole on completion of drilling.

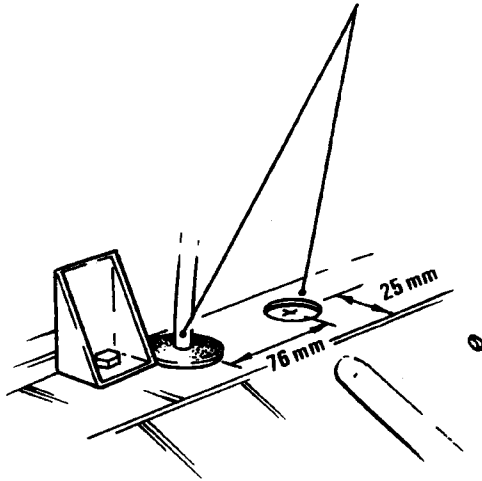

10. Fit rubber grommet H9 5325 99 942 3430 into drilled hole. Pass both extension leads up through centre of grommet.

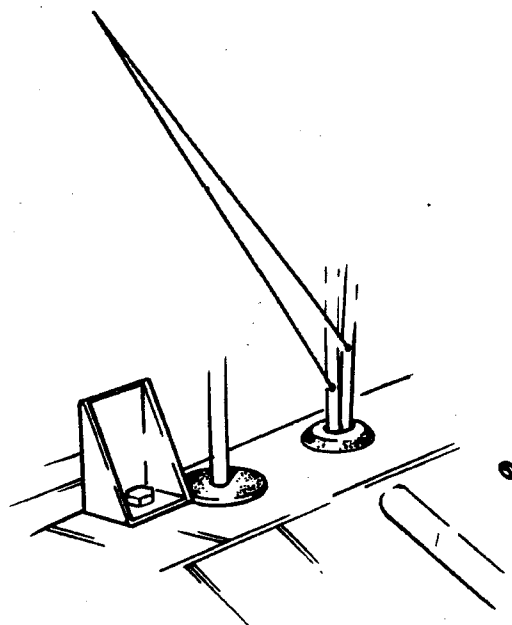

TASK 32. IGNITION AND THERMOSTART SWITCHES (continued)

11. Pass extension leads up under dash and through pre-drilled hole in dash. Fit rubber grommet H9 5325 99 942 3430 over both extension leads.

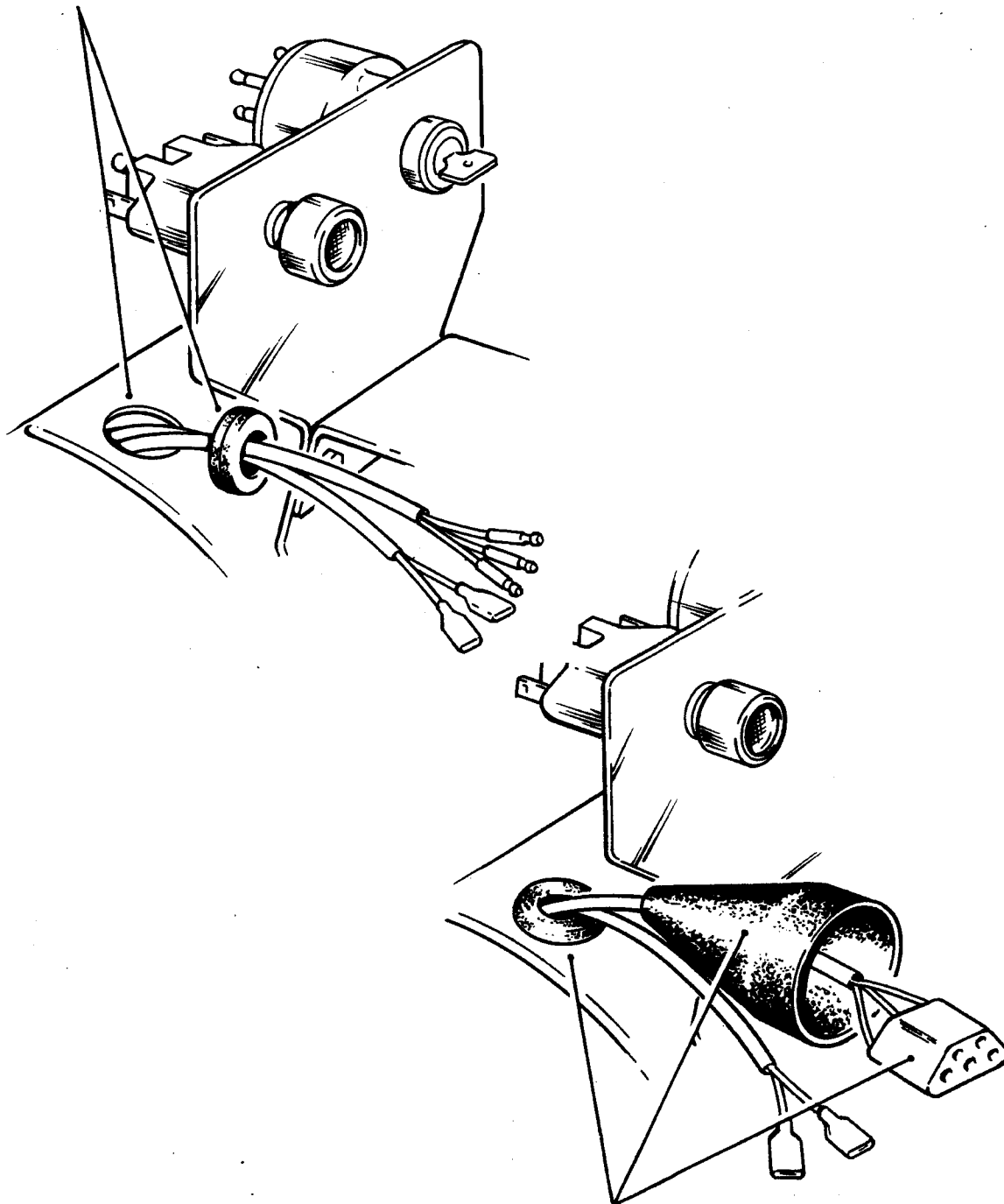

12. Fit ignition switch rubber boot onto ignition switch extension lead. Refit female plug. Fit rubber grommet into hole in dash.

TASK 32. IGNITION AND THERMOSTART SWITCHES (continued)

13. Connect ignition switch extension lead to ignition switch, and fit rubber boot.

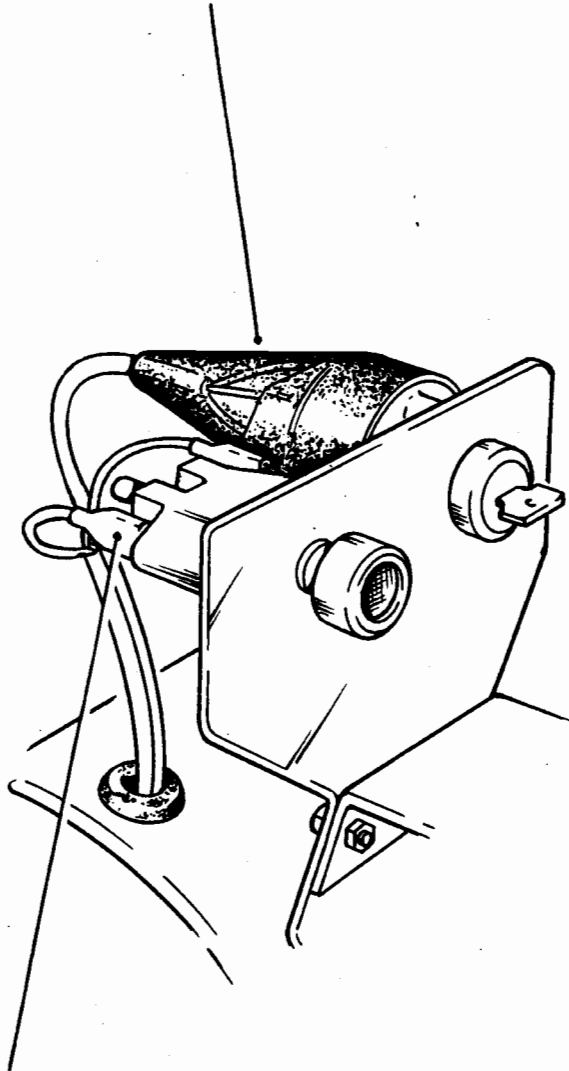

14. Connect thermostart extension lead to thermostart switch.

TASK 32. IGNITION AND THERMOSTART SWITCHES (continued)

15. Pass ignition and thermostart extension leads back along inside of chassis. Pass leads up from chassis alongside vehicle loom. Connect extension leads to their respective wiring connections on vehicle loom inside engine compartment.

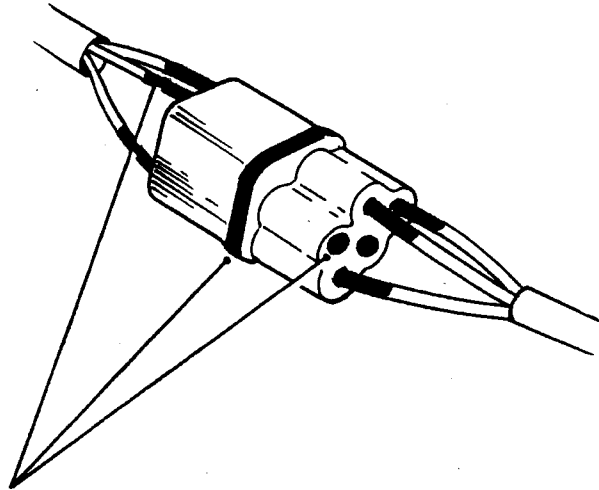

16. Brush an even coat of EC-750-C to male/female plug lead entry, around join of male/female plugs and fill blank cable entry holes.

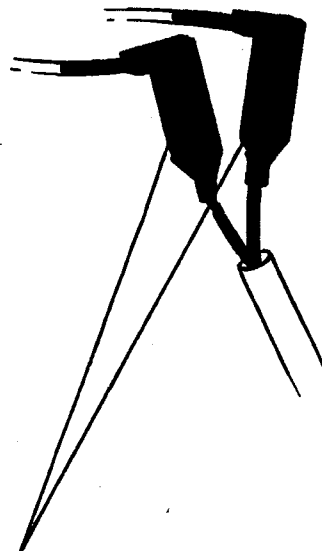

17. Brush an even coat of EC-750-C around cable entry on male/female terminal covers and joints of terminal covers.

 EC-750-C

TASK 32. IGNITION AND THERMOSTART SWITCHES (continued)

18. Remove screw as shown. Using clamp loop W17 5340 99 201 9092 secure extension leads and vehicle loom within clamp and secure clamp to box.

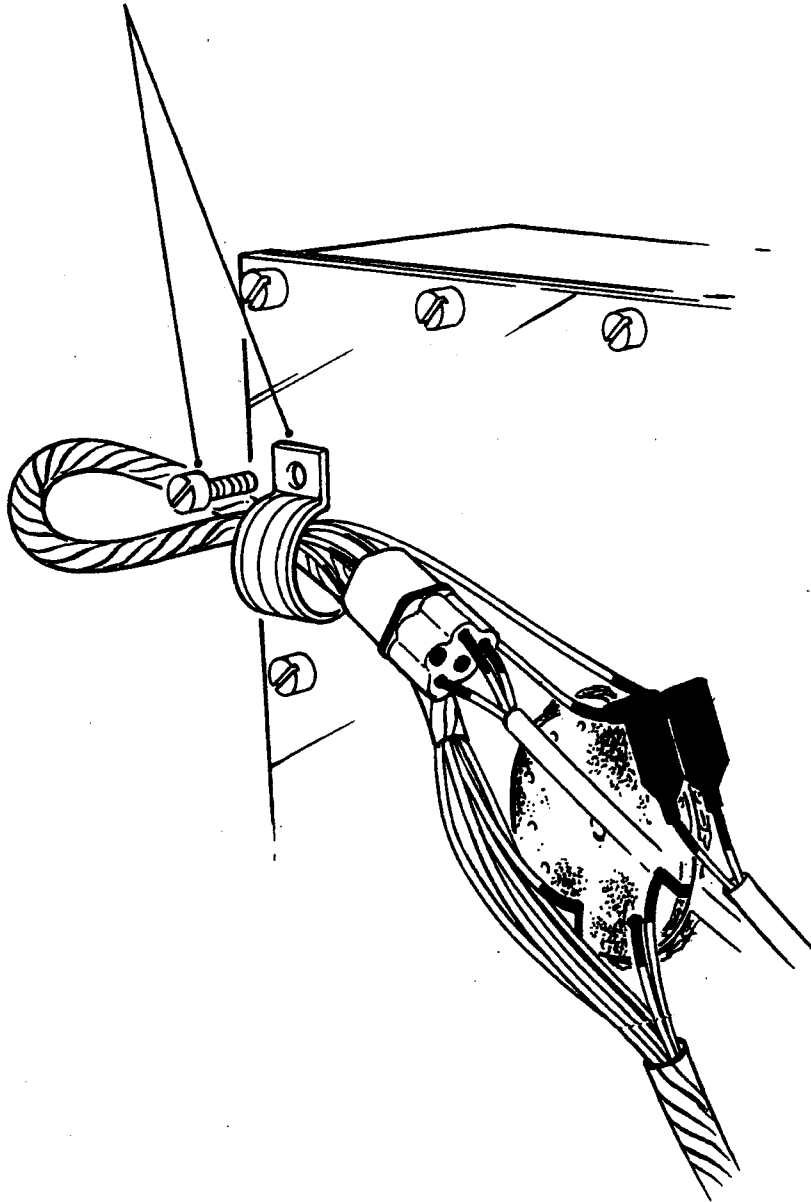

19. Secure extension leads along their length to vehicle loom using plastic cable ties 6MT4 5340 99 820 5371.

EC-750-C

TASK 33. AIR FILTER, COOPER TYPE

THIS TASK TO BE CARRIED OUT WITH THE ASSISTANCE OF A VEHICLE MECHANIC

Note ...

One of two alternative types of air cleaner are fitted. Select Task 33 or 34 according to type.

1. Remove air filter element from casing. Remove rubber valve. Stow rubber valve in a safe place on vehicle.
2. Brush an even coat of EC-750-C around the inside circumference and joint seam as shown.

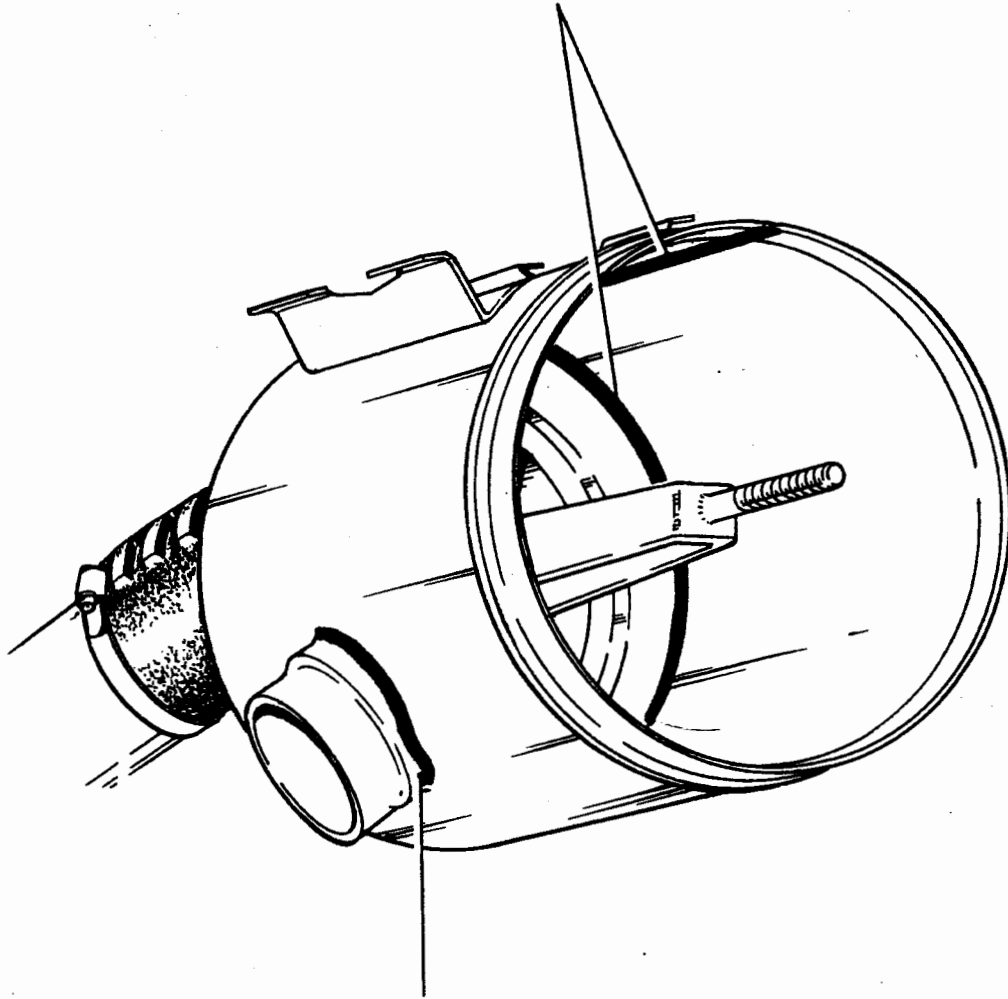



3. Brush an even coat of EC-750-C around joint of filter intake to casing.

 EC-750-C

TASK 33. AIR FILTER, COOPER TYPE (continued)

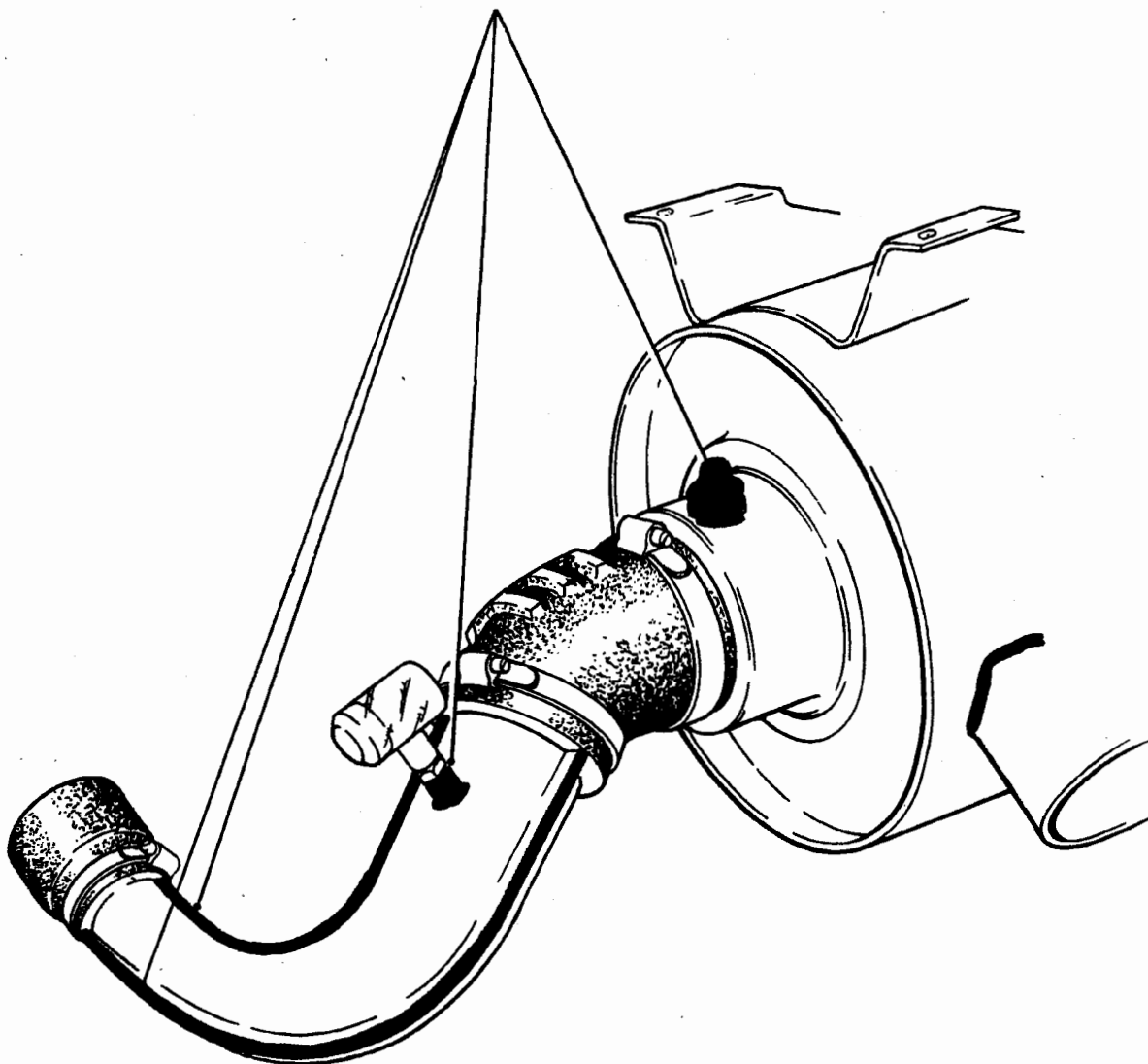
4. Brush an even coat of EC-750-C along both edges of turbo charger inlet, around base of indicator and union and over and around blanking cap.



 EC-750-C

TASK 33. AIR FILTER, COOPER TYPE (continued)

5. Brush an even coat of EC-750-C around base of particle discharger.

6. Repeat paras 2, 3, 4 and 5 after the first coat of EC-750-C has dried.

7. Refit air filter element and end cover.

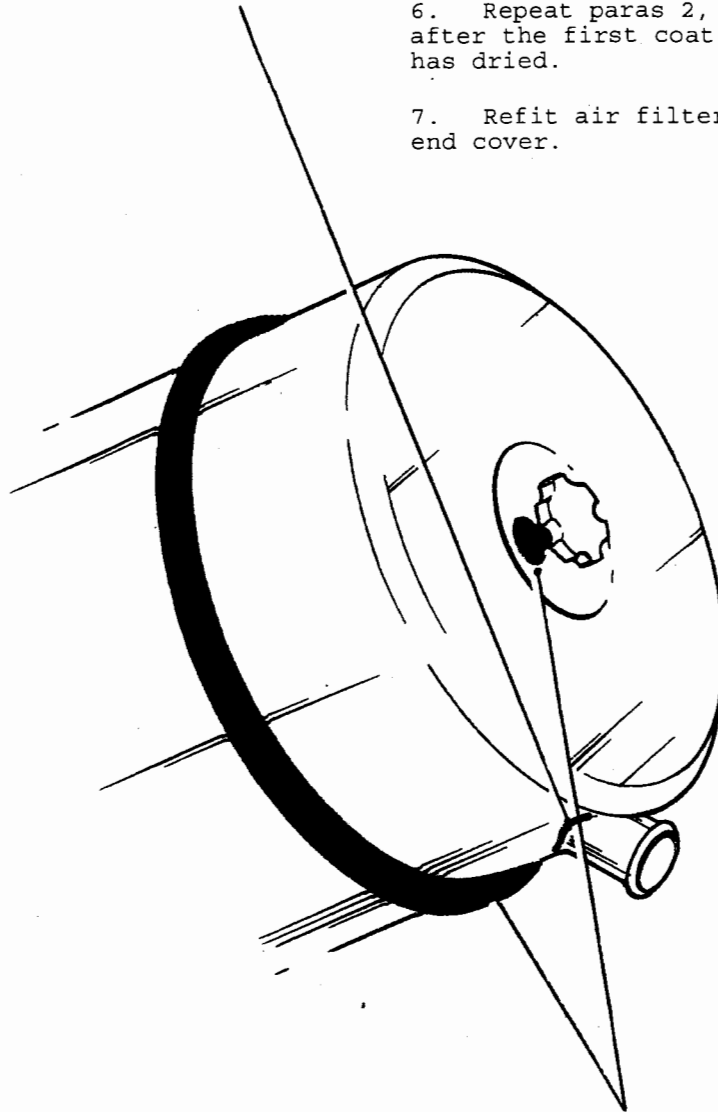

8. Brush an even coat of EC-750-C around end cover joint ensuring the gap is completely filled, around end cover screw and onto end cover. Allow first coat to dry before applying a second coat.

 EC-750-C

TASK 33. AIR FILTER, COOPER TYPE (continued)

9. Stretch a rubber cover 6WPG 2540 99 816 1916 (WPG 7857) over indicator. Brush an even coat of EC-750-C around circumference of rubber grommet base.

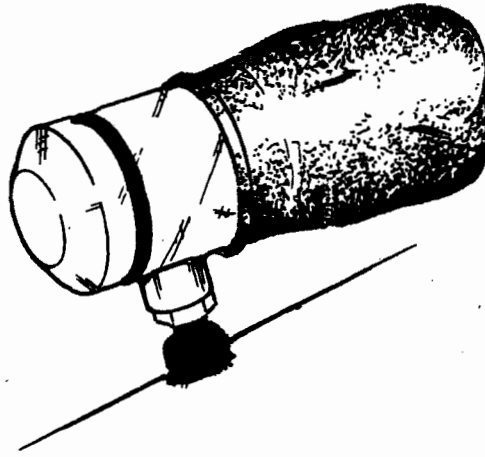

10. Fit a 1.1/4 in. dia. non-return valve 6WPG 2540 99 818 8177 (WPG 9173) over mouth of particle discharger and secure with a plastic cable tie 6MT4 5340 99 820 5371.

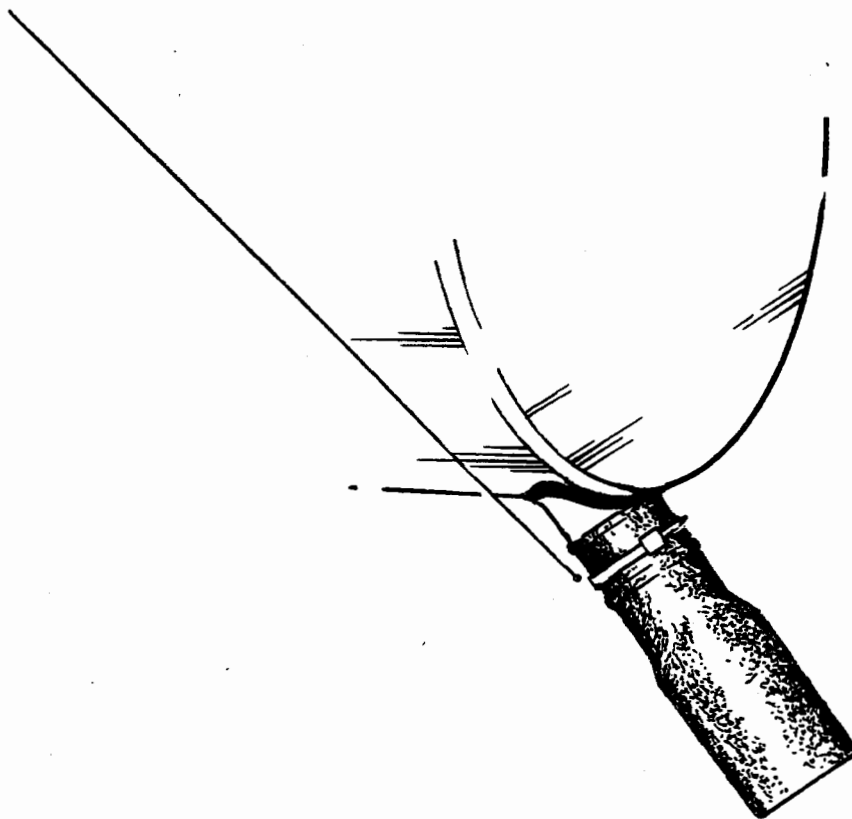

 EC-750-C

TASK 33. AIR FILTER, COOPER TYPE (continued)

11. Drill two 8.5 mm. dia. holes to dimensions shown, taking care not to damage insulating material in cab when drill breaks through.

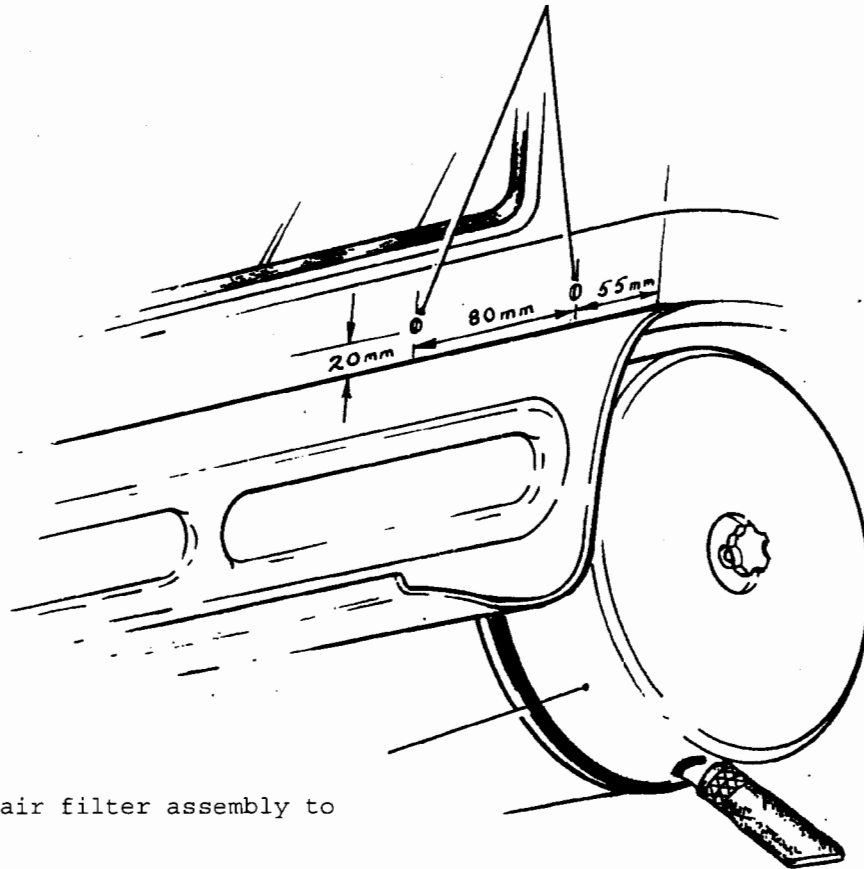

12. Refit air filter assembly to vehicle.

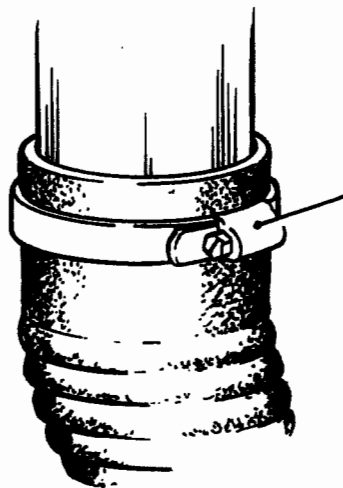

13. Secure hose non-metallic
6WPG 4720 99 731 0611 (WPG 9380)
to base of air intake extension
6WPG 2990 99 730 9552 (WPG 9371)
with a 90 mm - 120 mm hose clamp
6MT1 4730 99 533 2972.

EC-750-C

TASK 33. AIR FILTER, COOPER TYPE (continued)

14. Fit air intake extension to rear of cab, ensuring to fit backing washer/strip on the inside of the vehicle cab.

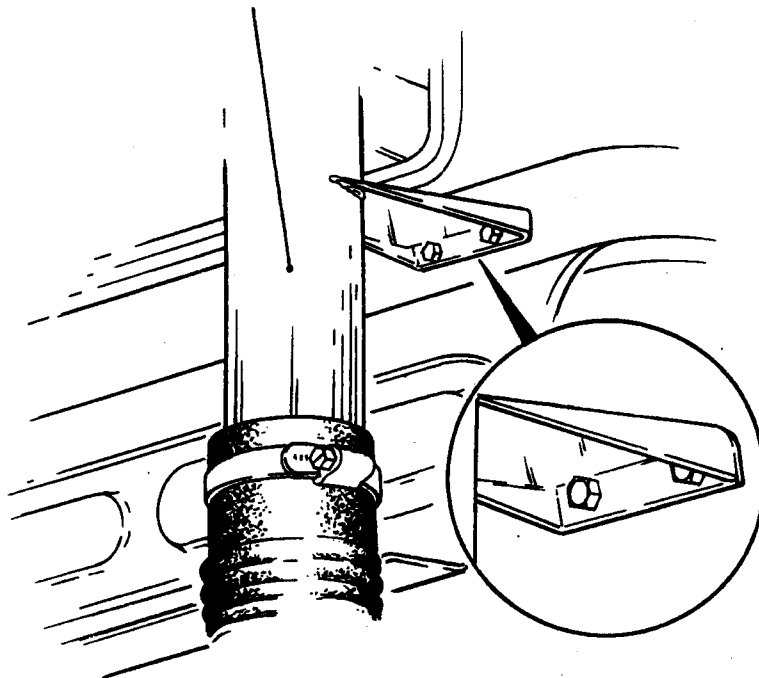

15. Position air intake extension top bracket so that edge of bracket is square with back of cab underneath rain water channel. Ensure that air intake extension is in a vertical position. Mark position where holes of bracket fall and drill two 6.5 mm dia holes and secure bracket to rain water channel.

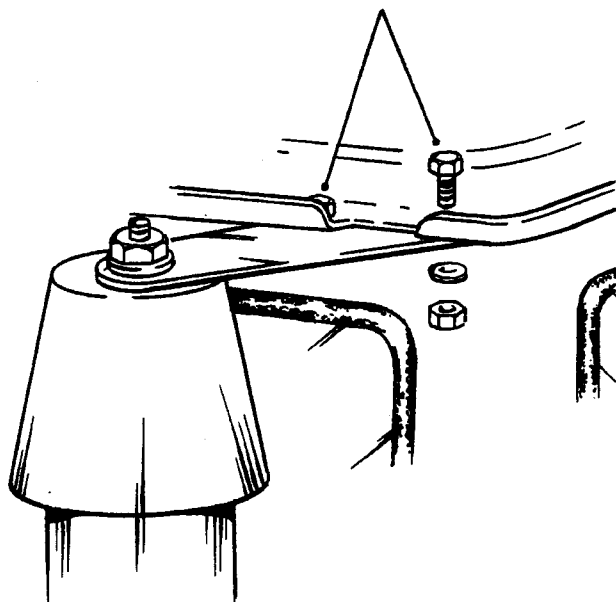

16. Fit free end of hose non-metallic to vehicle air filter intake and secure with a 90 - 120 mm hose clamp, 6MT1 4730 99 533 2972.

TASK 34. AIR FILTER, AC TYPE

THIS TASK TO BE CARRIED OUT WITH THE ASSISTANCE OF A VEHICLE MECHANIC.

1. Remove air filter element from casing. Remove turbocharger inlet from filter body and rubber valve from particle discharger. Stow rubber valve in a safe place on vehicle.

2. Brush an even coat of EC-750-C over external joint seams of casing.

3. Brush an even coat of EC-750-C over internal joint seams of casing.

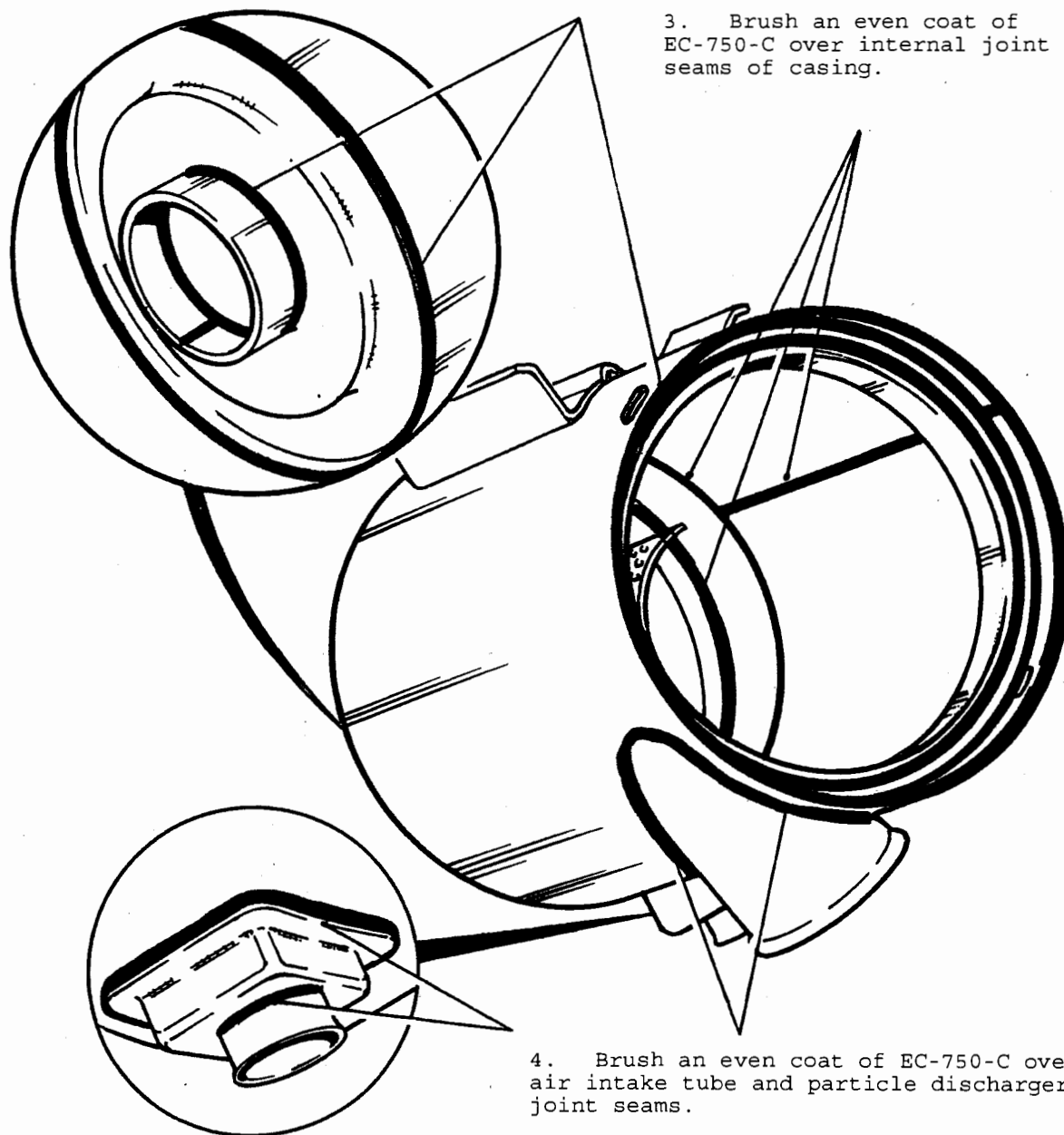

4. Brush an even coat of EC-750-C over air intake tube and particle discharger joint seams.

5. Repeat paras 2, 3 and 4 when first coat of EC-750-C has dried.

■ EC-750-C

TASK 34. AIR FILTER, AC TYPE (continued)

6. Check condition of rubber seal on end cover of air filter casing. Renew if damaged. Carefully brush an even coat of EC-750-C over the mating face for the rubber seal on the air filter body ensuring that the metal overlap joint is covered.

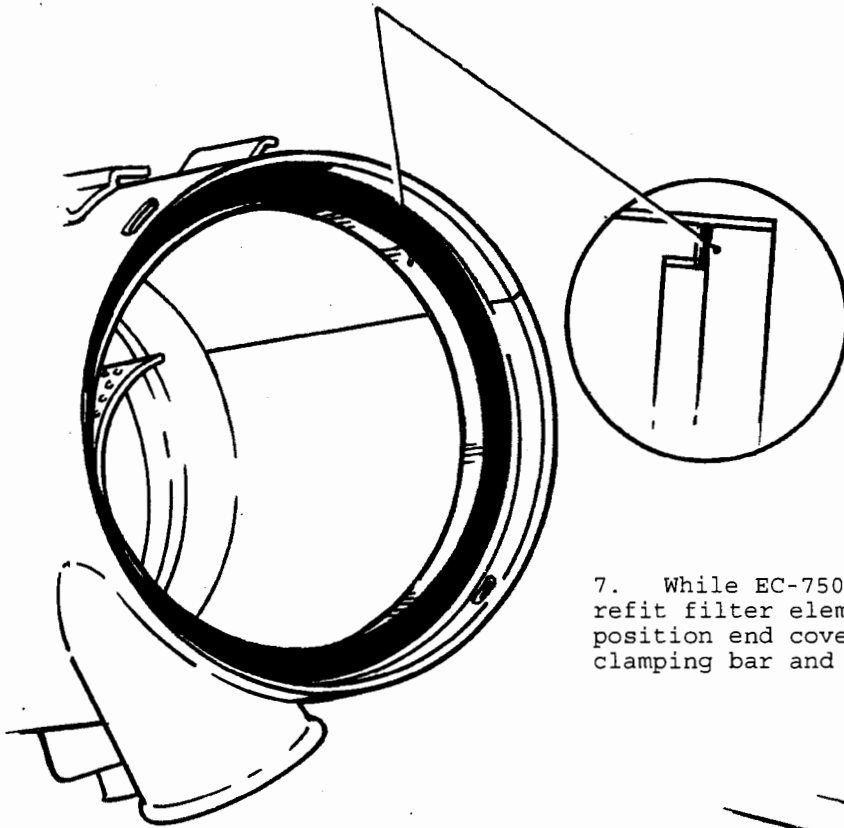

7. While EC-750-C is still tacky, refit filter element into casing, position end cover centrally, fit clamping bar and tighten clamp.

8. Brush an even coat of EC-750-C around edges of rubber seal to filter casing and filter end cover.

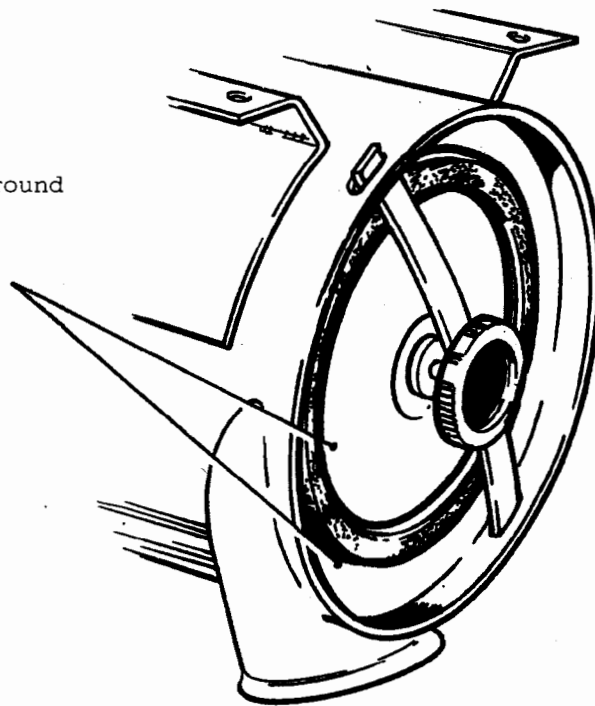

 EC-750-C

TASK 34. AIR FILTER, AC TYPE (continued)

9. Carefully check condition of both rubber sleeves on turbocharger inlet swan neck. Renew sleeves if damaged.

10. Brush an even coat of EC-750-C over external joint seams of turbocharger inlet and around base of indicator. Repeat with second coat of EC-750-C when first coat is dry.

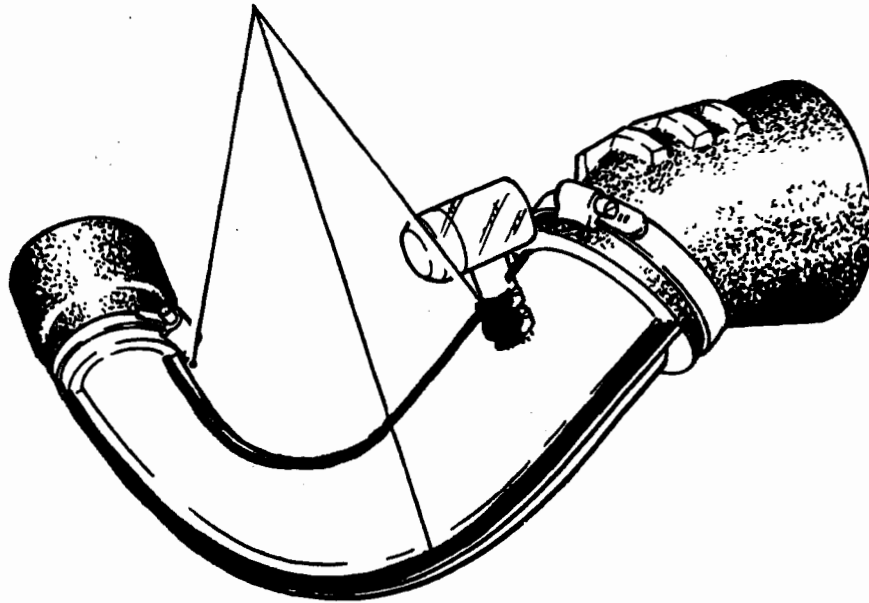

11. Fit cover elastic No 5 6WPG 2540 99 816 1916 (WPG 7857) over end of indicator. Brush an even coat of EC-750-C around circumference of rubber grommet base.

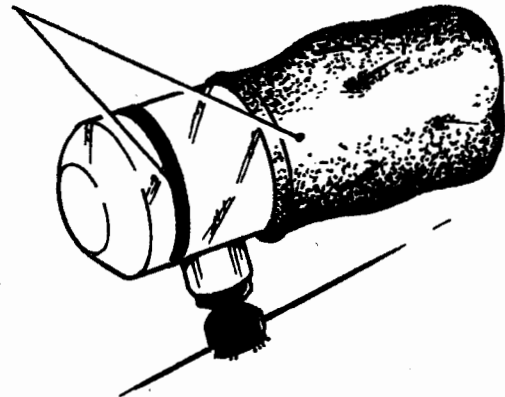
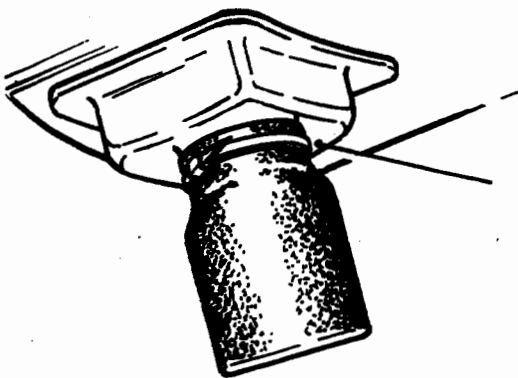

12. Fit valve non-return 1¼ in. dia. 6WPG 2540 99 818 8177 (WPG 9173) over particle discharger on air filter casing and secure with a plastic cable tie 6MT4 5340 99 742 6346.

■ EC-750-C

TASK 34. AIR FILTER, AC TYPE (continued)

13. Drill two 8.5 mm dia. holes to dimensions shown taking care not to damage insulating material in cab when drill breaks through.

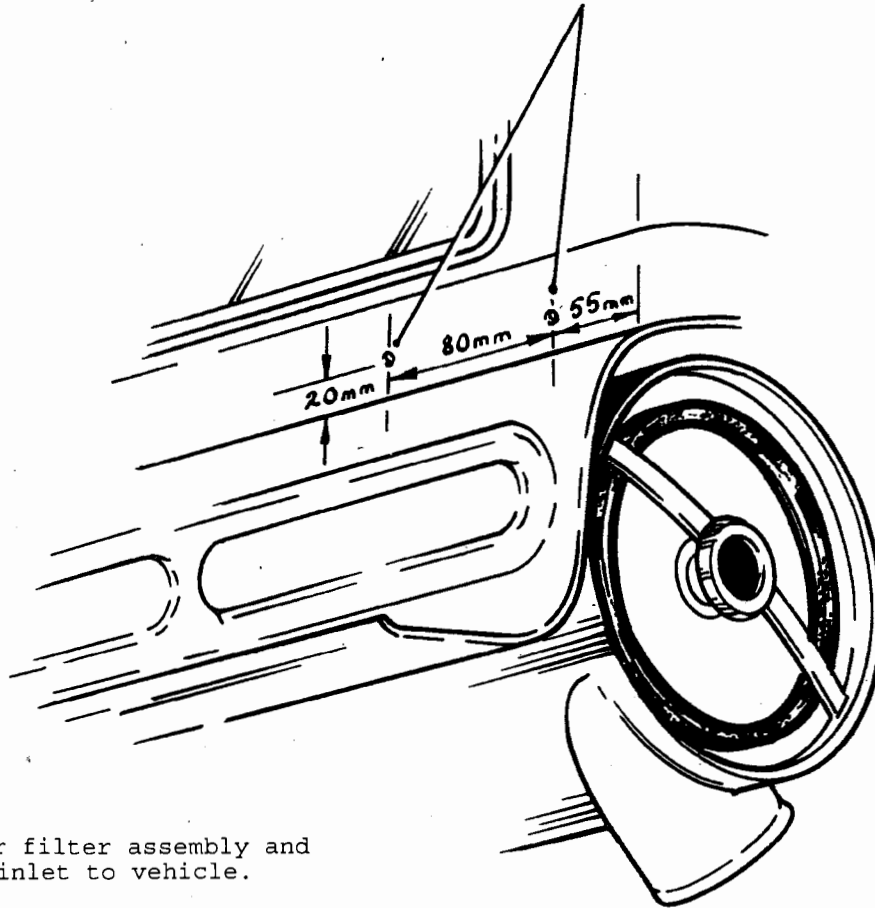

14. Refit air filter assembly and turbocharger inlet to vehicle.



15. Secure hose non-metallic 6WPG 4720 99 731 0611 (WPG 9380) to base of air intake extension 6WPG 2990 99 730 9552 (WPG 9371) with 90 mm - 120 mm hose clamp 6MT1 4730 99 533 2972.

EC-750-C

TASK 34. AIR FILTER, AC TYPE (continued)

16. Fit air intake extension to rear of cab ensuring to fit backing strip on the inside of the vehicle cab.

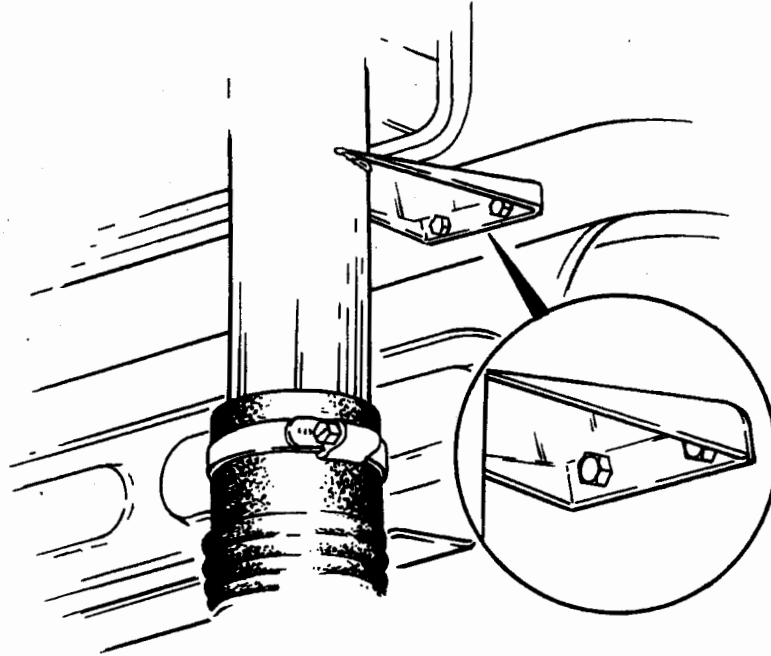

17. Position air intake extension top bracket so that edge of bracket is square with back of cab underneath rain water channel. Ensure that air intake extension is in a vertical position.

18. Mark position where holes of bracket fall and drill two 6.5 mm dia. holes.

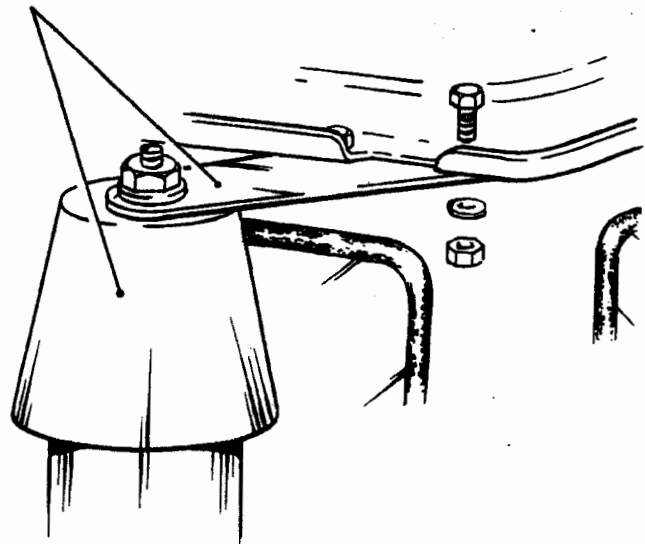

19. Secure top bracket of air intake extension to rain water channel with bolts provided.

TASK 34. AIR FILTER, AC TYPE (continued)

20. Fit a 75 mm length of rubber hose 6MT6 4720 99 805 7805 to air filter intake and secure with a 90 mm - 120 mm hose clamp 6MT1 4730 99 533 2972.

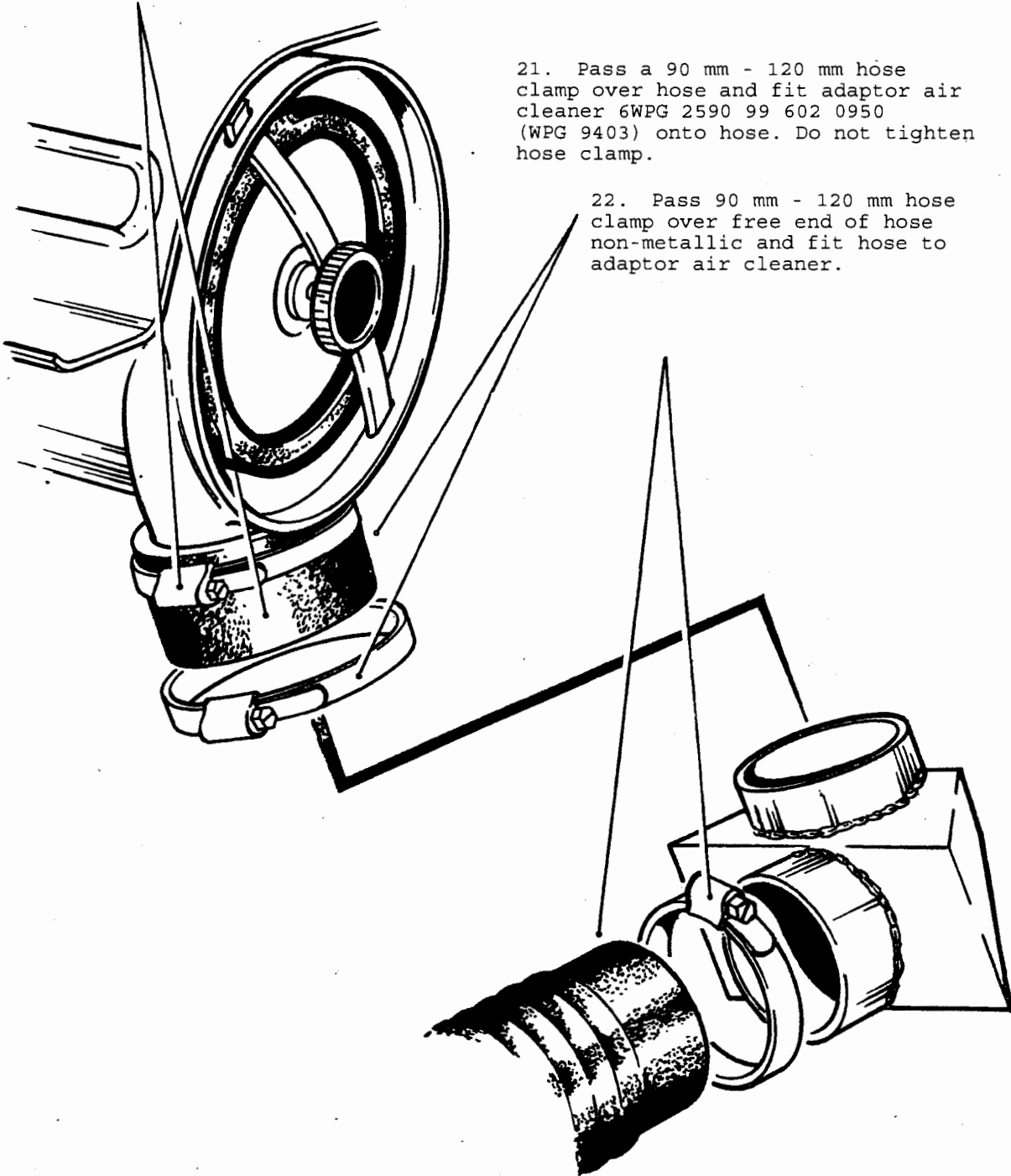

23. Check alignment of adaptor air cleaner and hose non-metallic ensuring that hose is clear of vehicle jack leg runner. Tighten all hose clamps.

EC-750-C

TASK 35. SECURING OF BREATHER HOSES (4)

1. Pass brake master cylinder actuator breather hoses (2) and gearbox breather hose through the plastic straps as shown. Pass breather hoses beneath cowling and remove any excess length. Tighten securing nuts on straps.

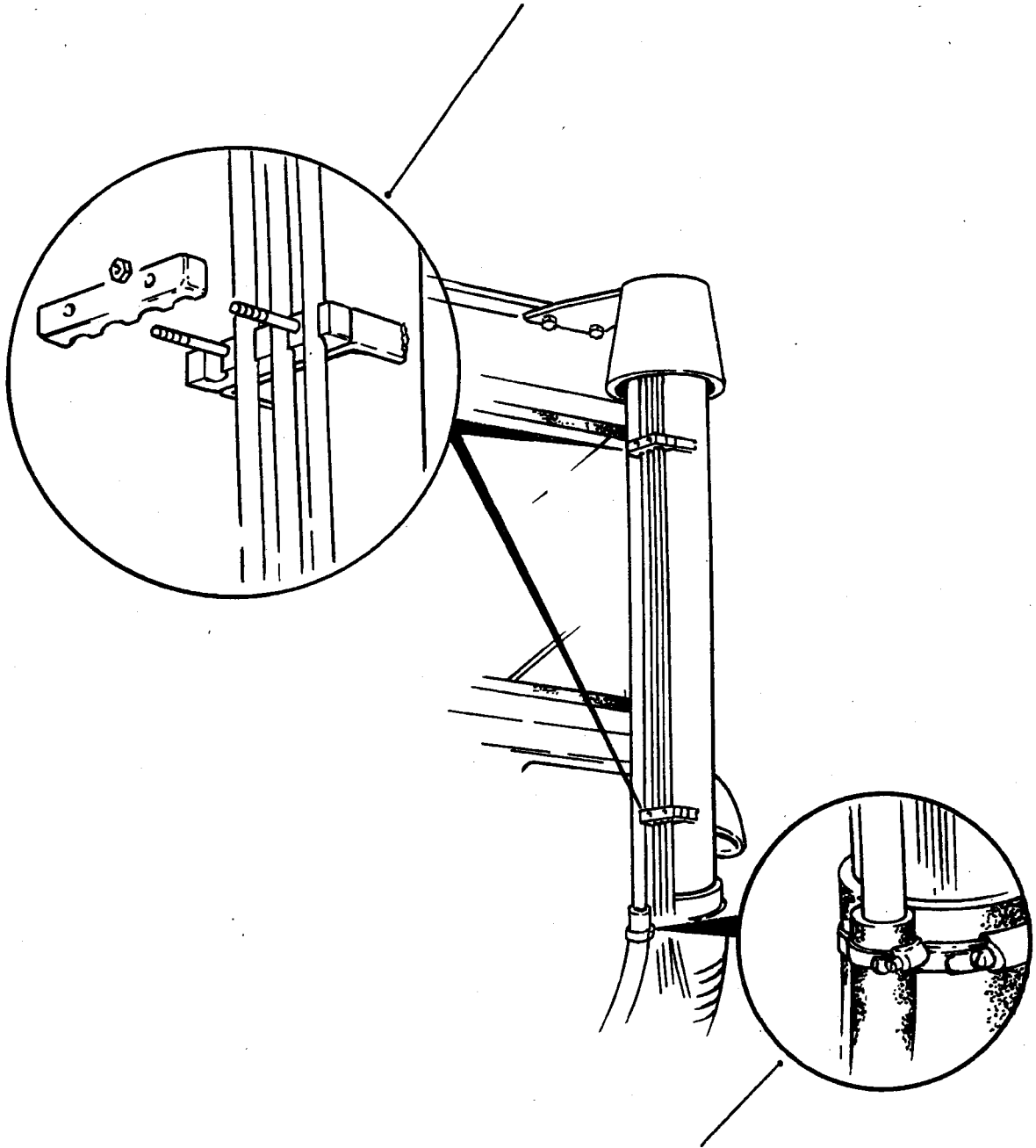

2. Fit free end of crankcase breather hose (early type vehicles) or oil filler cap breather hose (later type vehicles) onto air filter intake extension. Secure with a 27 mm - 40 mm hose clamp 6MT1 4730 99 533 2963.

TASK 36. WINDSCREEN WASHER MOTOR AND WINDSCREEN WIPER MOTOR SUPPRESSOR

1. Release pump from bulkhead; do not disconnect electrical terminals or windscreen washer pipes.
2. Brush an even coat of EC-750-C over and around terminal cover base, terminal covers and for 12mm along the length of each lead.

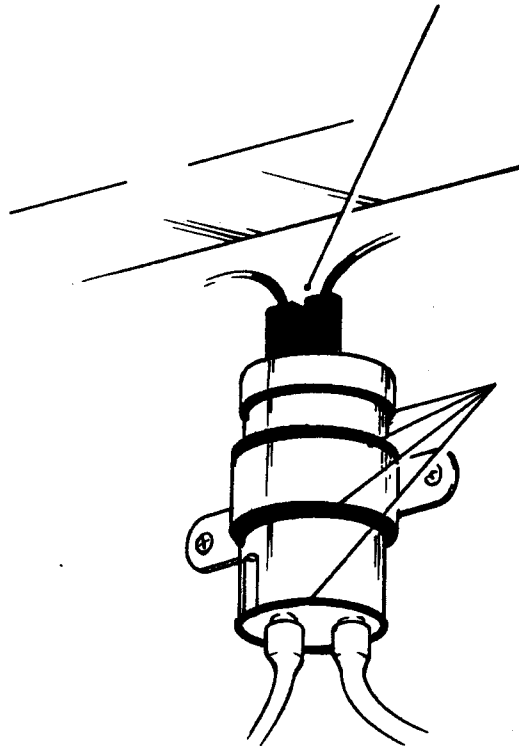

3. Brush an even coat of EC-750-C in positions indicated. Ensure that the small square holes are covered.

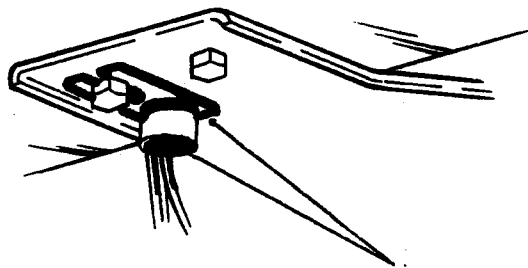

4. Remove suppressor from bracket beneath dash and brush an even coat of EC-750-C on base and around lead entry to suppressor, around circumference of suppressor where it joins mounting plate and on the reverse side of mounting plate. Allow EC-750-C to dry; refit suppressor to bracket.

 EC-750-C

TASK 37. BATTERY MASTER SWITCH

THIS TASK TO BE CARRIED OUT WITH THE ASSISTANCE OF A VEHICLE MECHANIC.

1. Remove cap from master switch and remove base of switch from cab floor. File a 6.5 mm dia. half round drain hole in lower side of base.

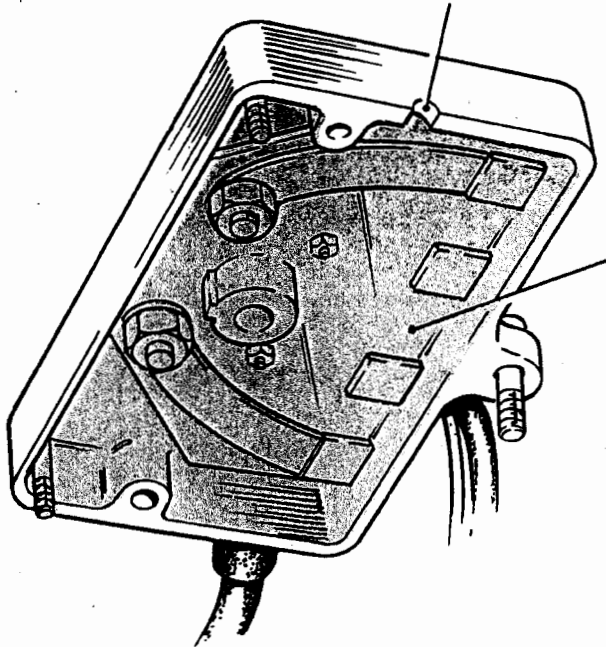

2. Apply an even coat of silicone compound over whole of underside of base.

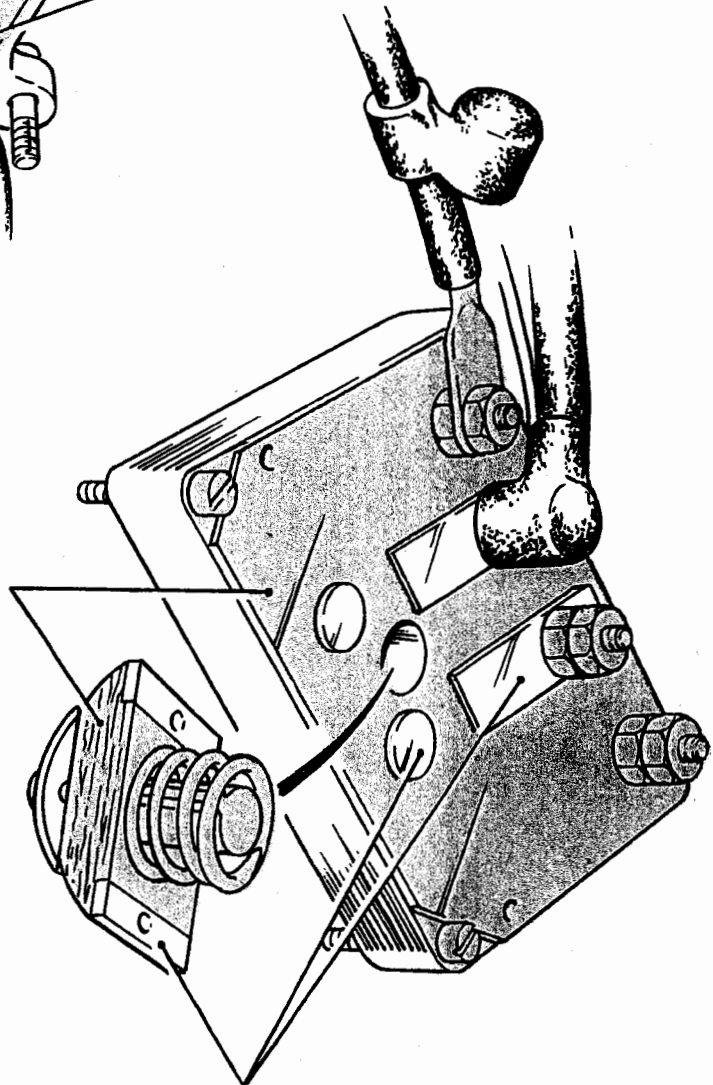

3. Slide rubber terminal covers back along leads. Apply an even coat of silicone compound over terminal connections, top face of base and switch assembly. Refit terminal covers.

4. Do not in any circumstances apply silicone compound to switch contact surfaces.

 Compound, silicone

TASK 37. BATTERY MASTER SWITCH (continued)

5. File a 6.5 mm dia. half round drain hole in lower side of switch cap.

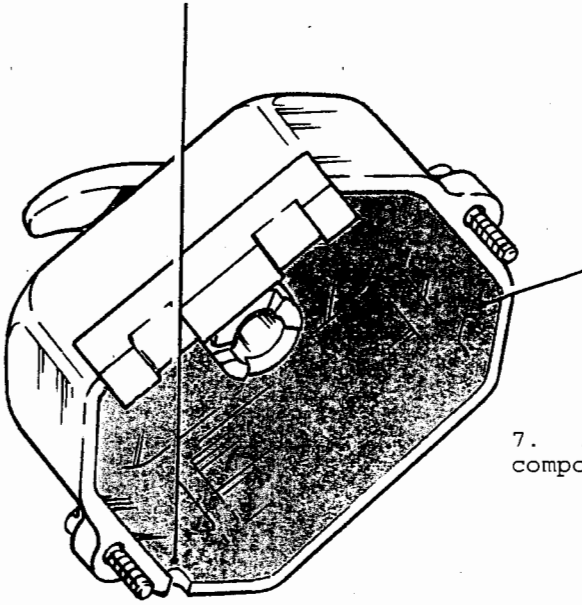

6. Apply an even coat of silicone compound over inside of cap. Refit cap.

7. Apply an even coat of silicone compound over outer spindle and nut.

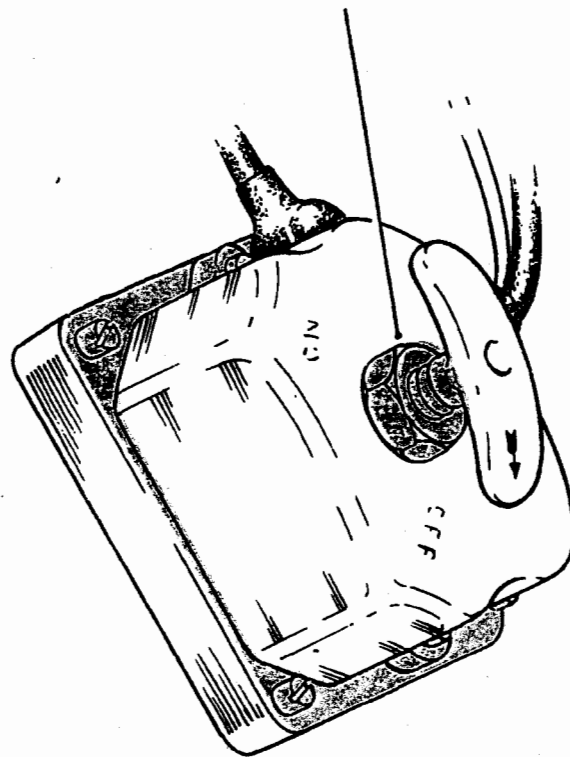

8. Refit switch assembly to cab floor.

 Compound, silicone

TASK 38. TYRE INFLATOR UNIT

THIS TASK TO BE CARRIED OUT WITH THE ASSISTANCE OF A VEHICLE MECHANIC.

1. Remove tyre inflator unit from the vehicle.
2. Remove plastic pipe from back of tyre inflator gauge and inflator unit. Remove gauge.
3. Remove gauge mounting bezel.

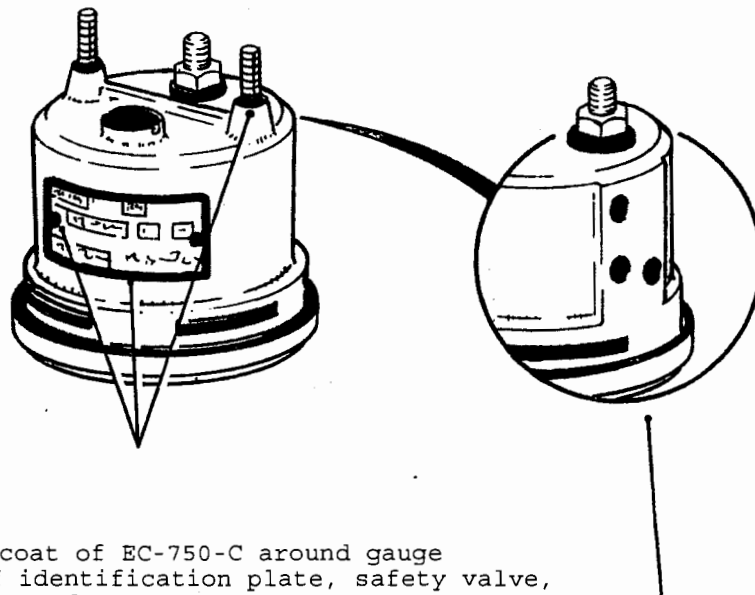

4. Brush an even coat of EC-750-C around gauge union, perimeter of identification plate, safety valve, screws and mounting studs.

5. Brush an even coat of EC-750-C around circumference of gauge as indicated and also to positions shown.

6. Repeat paras 4 and 5 when EC-750-C is dry.

7. Refit gauge mounting bezel to gauge, gauge into inflator unit. Refit pipe from gauge to inflator unit.

 EC-750-C

TASK 38. TYRE INFLATOR UNIT (continued)

8. Brush an even coat of EC-750-C around circumference of gauge and onto gauge glass. Allow first coat to dry before applying a second coat.

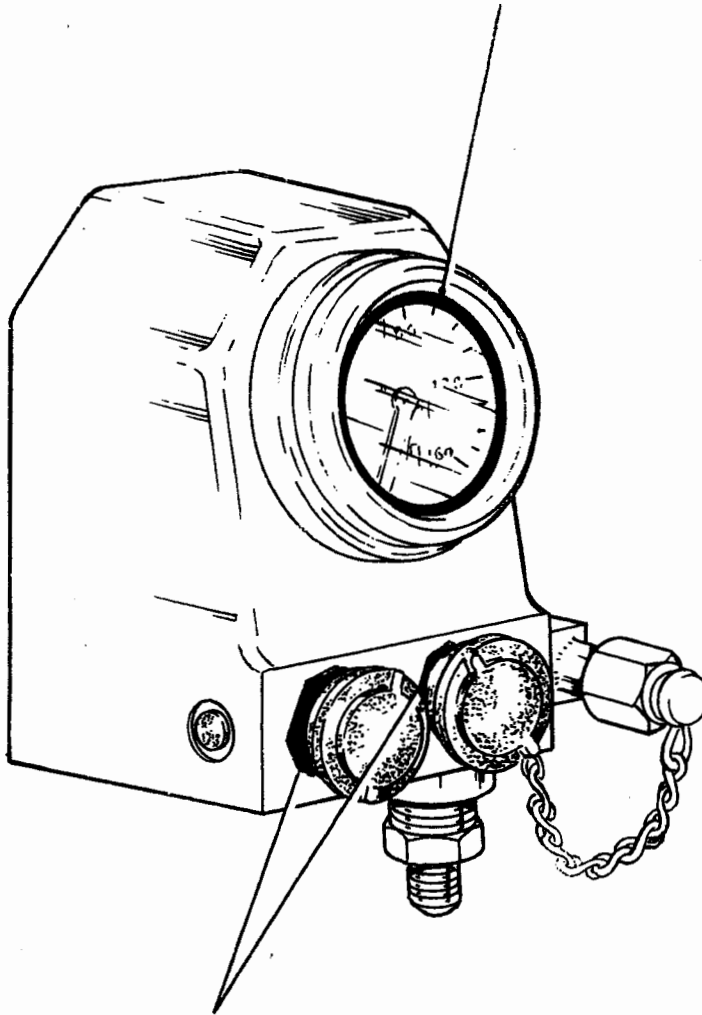

9. Brush an even coat of EC-750-C around unions of inflate-deflate buttons and onto rubber covers. Allow first coat to dry before applying a second coat.

10. Refit tyre inflator unit to vehicle.

11. Check that tyre inflator unit outlet cover is screwed on tight.

 EC-750-C

TASK 39. FUEL TANK SENDER UNIT

1. Apply an even coat of grease over fuel tank sender unit.

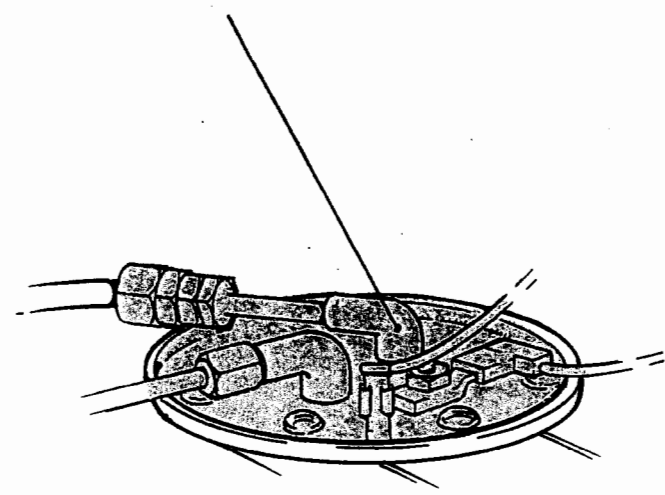

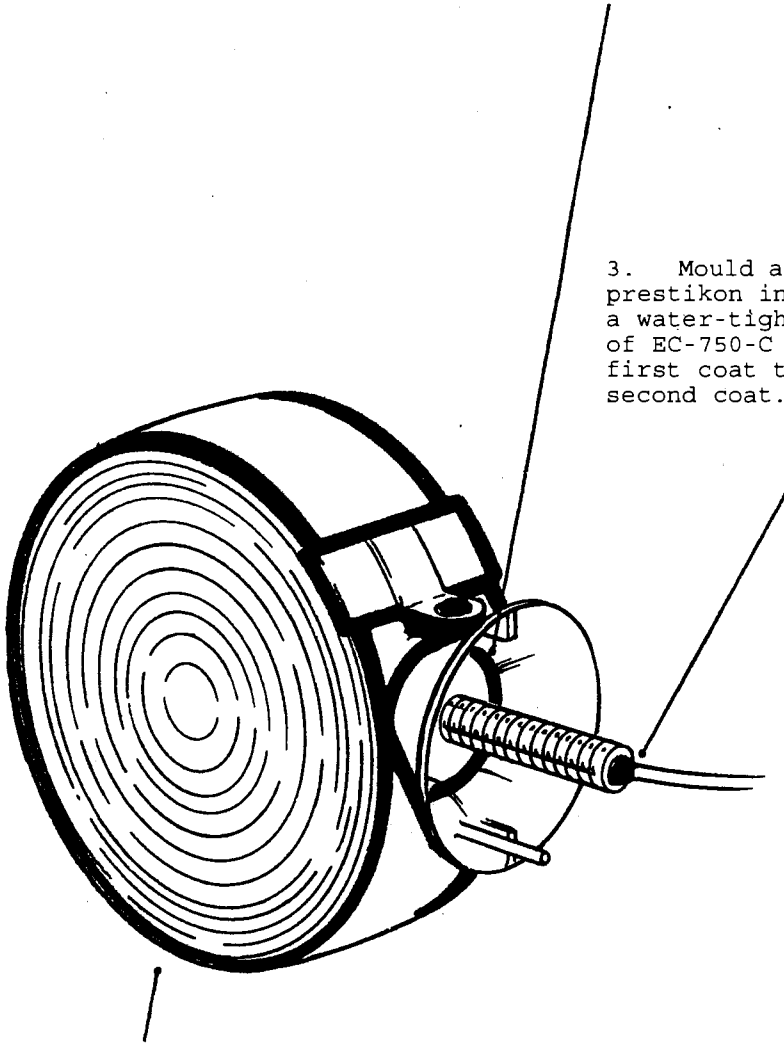

TASK 40. TURNLIGHTS FRONT (2)

1. Ease away inside panelling covering turnlight securing nut, remove turnlight securing nut. Disconnect electrical lead and remove turnlight.
2. Brush an even coat of EC-750-C around inner circumference of mounting bracket.



3. Mould a small quantity of prestikon into lead entry to form a water-tight seal. Brush a coat of EC-750-C over prestikon. Allow first coat to dry before applying second coat.

4. Brush an even coat of EC-750-C over rim of turnlight onto glass, over seams and over screwhead of clamp. Allow first coat to dry before applying a second coat.
5. Refit turnlight; reconnect electrical lead; refit panelling.
6. Repeat para 1 - 6 for remaining turnlight.

 Prestikon EC-750-C

TASK 41. TRAILER SOCKETS - 2 AND 12 PIN

12 PIN SOCKET

1. This task only applies when trailer sockets will not be in use.
2. Remove cap. Stretch a cover, hydraulic fluid reservoir No 2 6WPG 2540 99 822 7640 (WPG 9239) over 12 pin socket boss. Ensure that drainhole at bottom of boss is covered by the rubber cover.

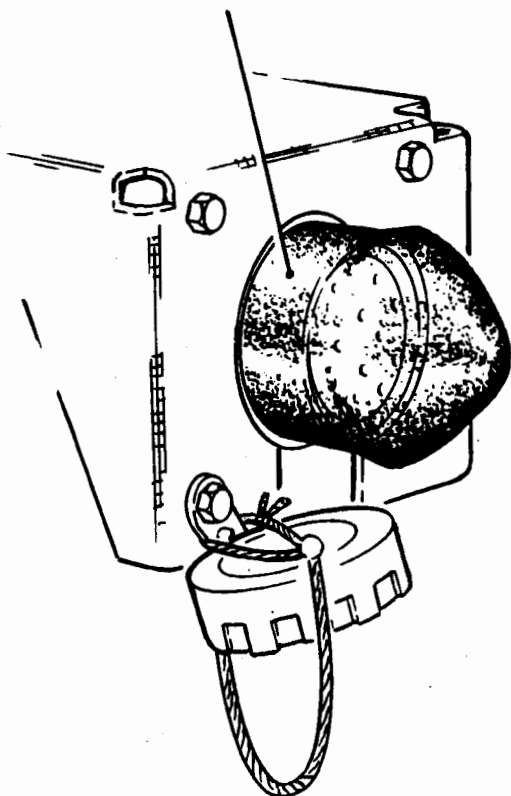

3. Secure cap to cap lead fixing as shown using line, polypropylene.

2 PIN SOCKET (2)

4. Ensure that sealing washer inside cap is serviceable; tighten cap onto pin socket.

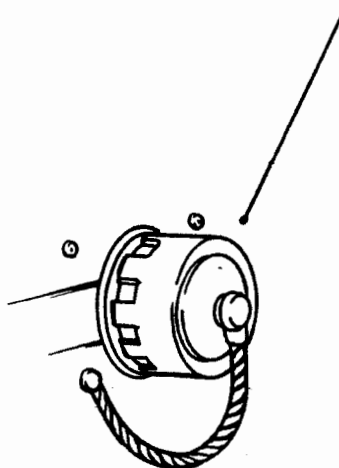

TASK 42. REAR AIR PALM COUPLINGS (2)

1. This task only applies when the couplings will not be in use.
2. If dummy coupling has hole through centre, seal with prestikon.
3. Loop a rubber band 6WPG 2540 99 816 2428 (WPG 7779) over inner section of dummy coupling.

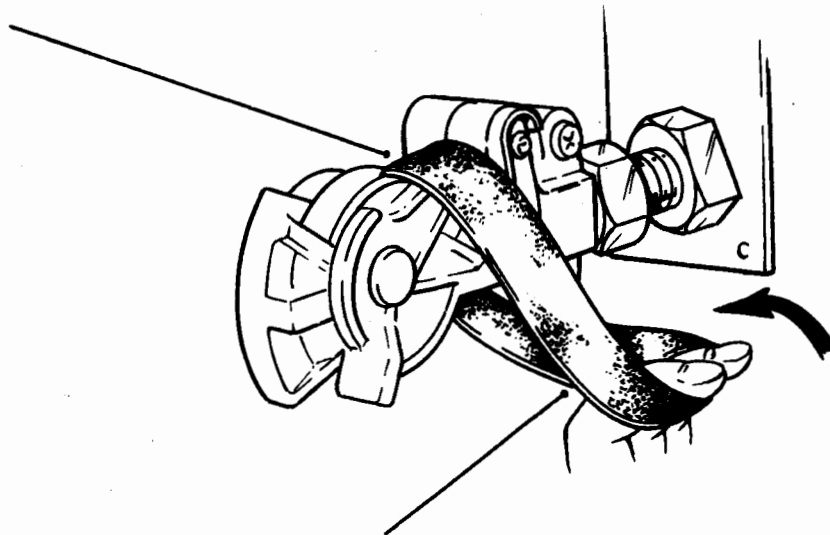

4. Twist rubber band to form second loop.
5. Pass second loop of rubber band over outer section of dummy coupling to ensure that dummy coupling is a tight fit in palm coupling.

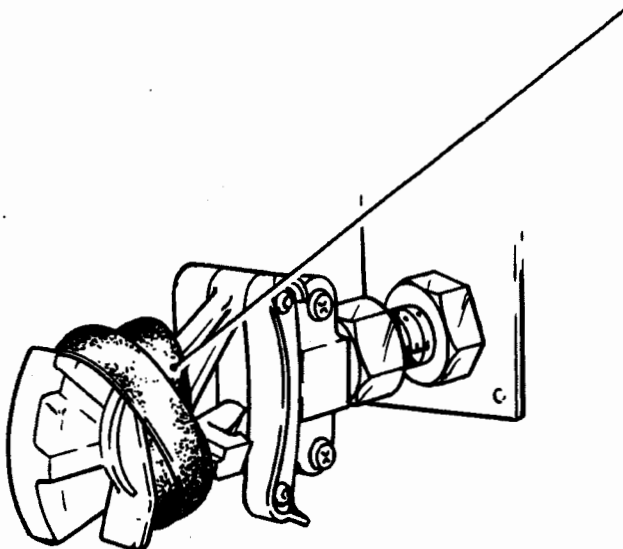

6. Carry out the same procedure on other coupling.

TASK 43. ENGINE OIL PRESSURE WARNING SWITCH

Note ...

Engine oil pressure switch is located on the nearside of engine behind the fuel injector pump.

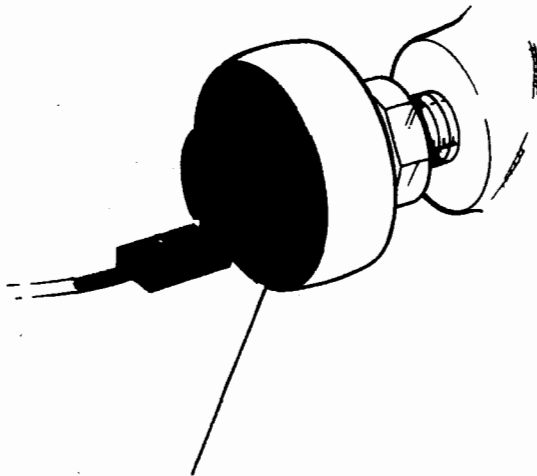

1. Brush an even coat of EC-750-C over face and connection of oil pressure switch and for 25 mm along the switch lead.



EC-750-C

TASK 44. LOW AIR PRESSURE WARNING SWITCHES (2)

Note ...

Air pressure warning switches are located on rear of air reservoir tanks.

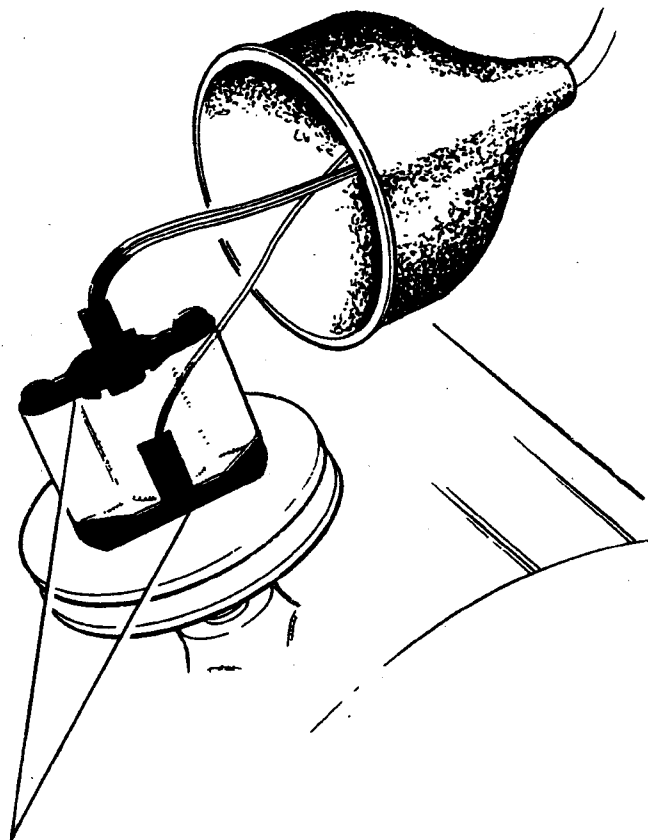

1. Remove dust cover from top of low air pressure warning switch. Brush an even coat of EC-750-C over top of switch, screw heads, terminals, around switch base and for 25 mm along each lead. Refit rubber dust cover.
2. Repeat the procedure in para 1 for the remaining switch.

 EC-750-C

TASK 45. TEMPERATURE GAUGE SWITCH

Note ...

Temperature gauge switch is located on the top front of the engine.

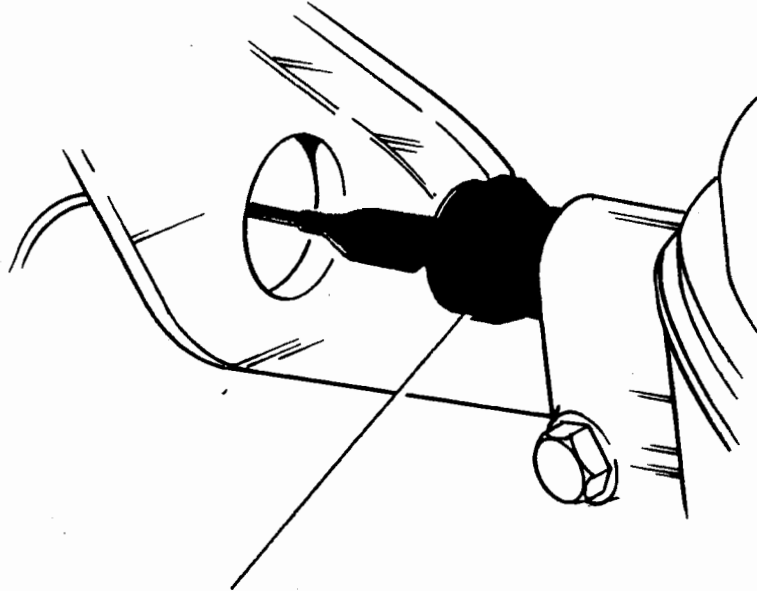

1. Brush an even coat of EC-750-C over face and connection of temperature gauge switch and for 25 mm along the switch lead.

 EC-750-C

TASK 46. FUEL INJECTION PUMP

THIS TASK TO BE CARRIED OUT WITH THE ASSISTANCE OF A VEHICLE MECHANIC.

1. Remove damper from back of fuel injection pump.
2. Stretch a rubber cover 6WPG 2540 99 816 1916 (WPG 7857) over damper. Refit damper.

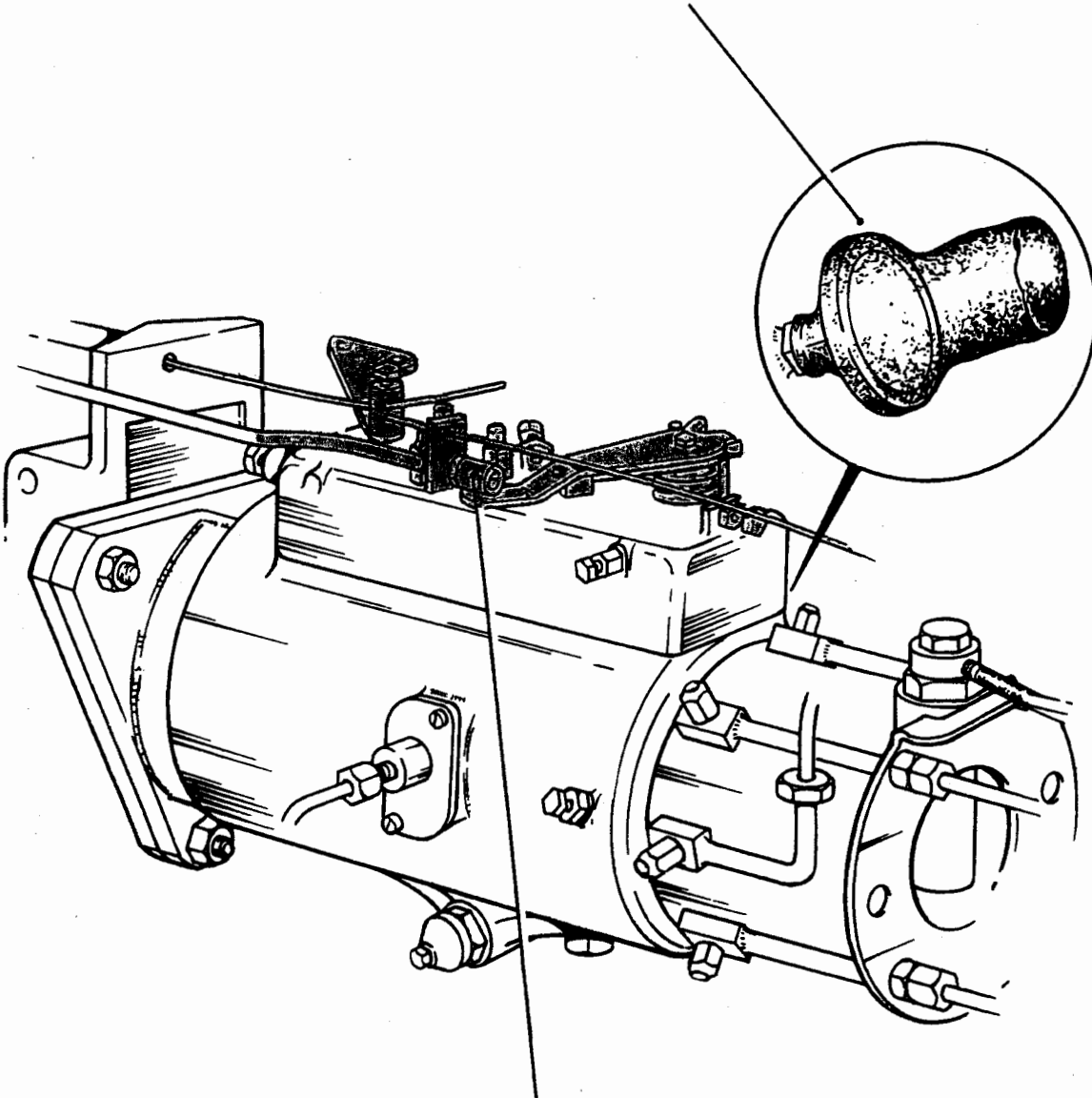

3. Apply an even coat of grease over all operating linkages and springs.

 Grease

TASK 47. INSTRUMENT PANEL AND WIPER MOTOR ETC.

1. Remove securing screws and withdraw instrument panel from dash panel.
2. Using silicone compound aerosol (WPG 8198) give the following items two coats of silicone compound allowing first coat to dry before applying a second.
 - 2.1 Back of instrument panel and leads.
 - 2.2 Back of Voltmeter.
 - 2.3 Flasher Unit.
 - 2.4 Air pressure gauge.
 - 2.5 Wiper motor.
 - 2.6 Air pressure buzzer.
 - 2.7 Fuses in fuse box.

TASK 48. PRESERVATION

1. For preservation against salt water corrosion, apply a coat of grease to the following:-
 - 1.1 Spare wheel lifting gear including cable.
 - 1.2 Clutch pedal bearing and linkage.
 - 1.3 Transfer box selector linkages.
 - 1.4 Main gearbox operating linkage.
 - 1.5 Steering linkage.
 - 1.6 Handbrake pivot and linkage.
 - 1.7 Tow hook pivot.
 - 1.8 Wheel nuts.
 - 1.9 Cab door hinges.
 - 1.10 Loose items of tools and equipment.

TASK 49. REFITTING ITEMS OF EQUIPMENT

THIS TASK TO BE CARRIED OUT WITH THE ASSISTANCE OF A VEHICLE MECHANIC

1. Refit the following items to the vehicle.
 - 1.1 Spare wheel.
 - 1.2 Engine radiator grill.
 - 1.3 Engine top cover and seats.
 - 1.4 Refit batteries to vehicle; reconnect and replace top cover.

TASK 50. FUNCTIONAL CHECK OF EQUIPMENT

1. Check the following items of equipment fitted to the vehicle are functioning correctly after waterproofing to Stage A:-

- 1.1 Lights main beam and dipped.
- 1.2 Side lights front and rear.
- 1.3 Direction indicators front and rear.
- 1.4 Rear fog lamps.
- 1.5 Number plate lamp.
- 1.6 Convoy lamp.
- 1.7 Stop lamps.
- 1.8 Horn.

2. Run engine to build up air pressure and check that there are no leaks on air braking system, cooling system, fuel system and that all items previously removed or fitted in Stage A are secure in their respective positions and are functioning normally.

3. If any of the above items in paras 1 and 2 are not functioning correctly, investigate the fault immediately and rectify.

TASK 51. WATERPROOFED EQUIPMENT MARKINGS STAGE A

Apply waterproofing equipment markings to vehicle as instructed on page 12 of this A.E.S.P. Ensure that the RED Stage B marker is covered with black adhesive tape.

TASK 52. WATERPROOFING MATERIALS FOR STAGE B

Collect the remaining waterproofing materials and this A.E.S.P. and stow in a safe place. These materials will be required for tasks in Stage B. Ensure a tow rope is available. Items removed for stowage are to be located in a safe place.

WATERPROOFING STAGE B

Note ...

The tasks listed in Stage B will normally be carried out in the final staging area where fuel and lubricants are available prior to embarking.

TASK 53. CHECK OF WATERPROOFING COMPLETED IN STAGE A

1. Carry out a check of all waterproofing tasks completed in Stage A to ensure that nothing has been damaged or displaced. Particular attention must be paid to the following:-

- 1.1 Sealing around clutch housing and clutch lever gaiter.
- 1.2 Air filter and air filter extension.
- 1.3 All waterproofing non-return valves.
- 1.4 All waterproofing breather tubing/hosing and connections.
- 1.5 Fuel injection pump.

TASK 54

1. Deflate tyres to cross country pressures. Front 41 P.S.I., Rear 80 P.S.I.

TASK 55. BRAKE MASTER CYLINDER LEAKAGE VENT

1. Fit aluminium rivet G1 5320 99 433 2289 into end of rubber tubing.

TASK 56. COMMERCIAL TYPE BATTERIES

Note ...

Because of the variation in design of commercial batteries, it may be necessary to consult the Unit Waterproofing Adviser.

1. Remove battery main cover.
2. Mould Prestikon around each filler cover on top of battery.
3. Apply a coat of preservative grease (PX7) over terminals. Refit terminal covers.
4. Refit battery main cover.

TASK 57. HEATER ASSEMBLY

THIS TASK TO BE CARRIED OUT WITH THE ASSISTANCE OF A VEHICLE MECHANIC.

1. Remove front radiator grill. Set the heater control lever to the Hot position. Remove radiator filler cap and half drain the cooling system. Disconnect white feed wire from heater switch. Detach the demist and water hoses from heater. Remove screws from the base of heater and remove heater assembly.

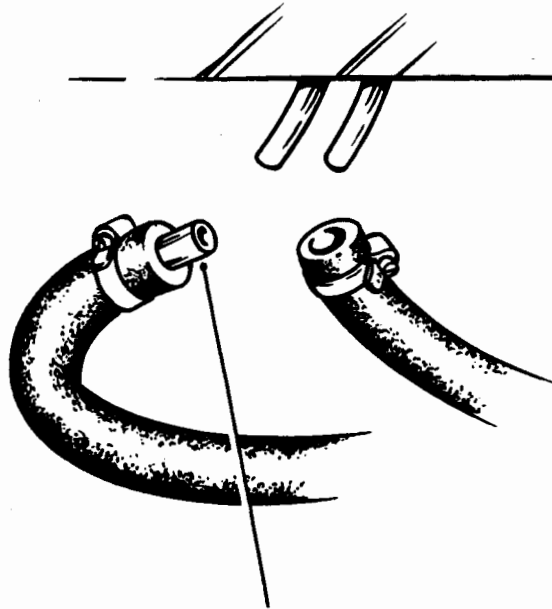

2. Connect water hoses with copper tubing 16 mm o.d. x 50 mm lg. G2 4710 99 964 9986 and secure with two hose clamps 22 mm - 30 mm, 6MT1 4730 99 533 2961. Secure hoses to an adjacent conduit using plastic cable ties 6MT4 5340 99 820 5371.
3. Cover end of disconnected motor feed lead with adhesive tape.
4. Refit cooling system to correct level. Refit front radiator grill.
5. Place heater assembly in a PVC bag 36 in. x 24 in. 6WPG 2540 99 816 2670 (WPG 8220) and stow in a safe place in the vehicle. Take precautions against damage occurring to the heater.

TASK 58. FRONT AND REAR AXLE BREATHERS (2)

Note ...

Check condition of rubber breather tubes, renew if necessary.

1. Fit a 1/4 in. dia. non-return valve 6WPG 2540 99 817 9523 (WPG 9138) to end of breather pipe on front axle.

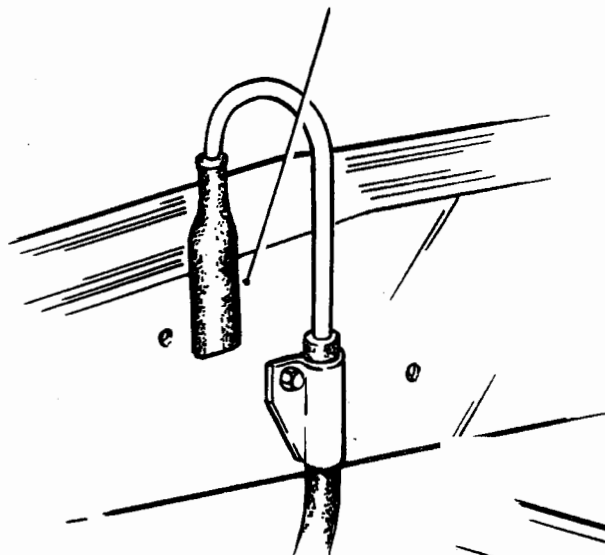

2. Fit a 1/4 in. dia. non-return valve 6WPG 2540 99 817 9523 (WPG 9138) to end of breather pipe on rear axle.

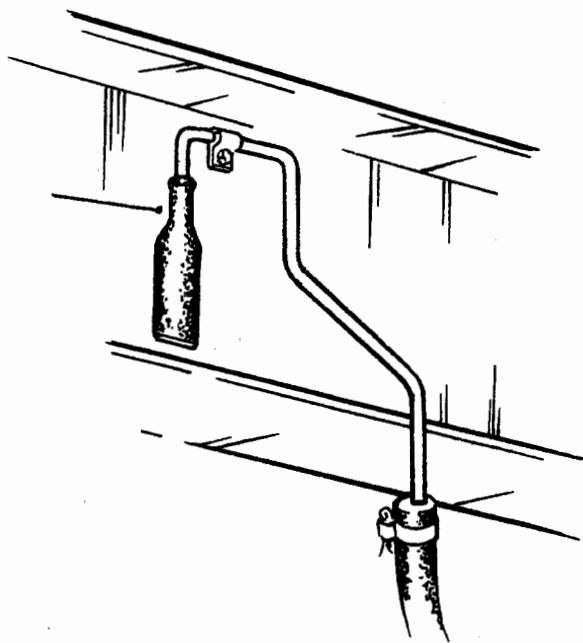

TASK 59. TRANSFER BOX BREATHER

1. Brush an even coat of EC-750-C around base of breather hose and onto transfer box casing.

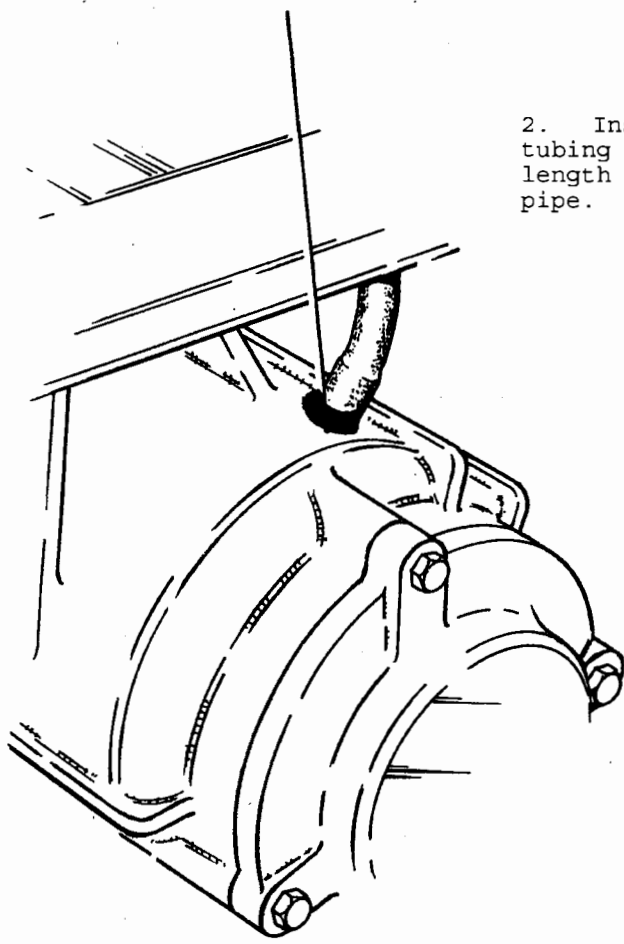

2. Insert a 50 mm length of 8 mm OD copper tubing G2 4710 99 964 9979 for half its length into end of transfer box breather pipe.

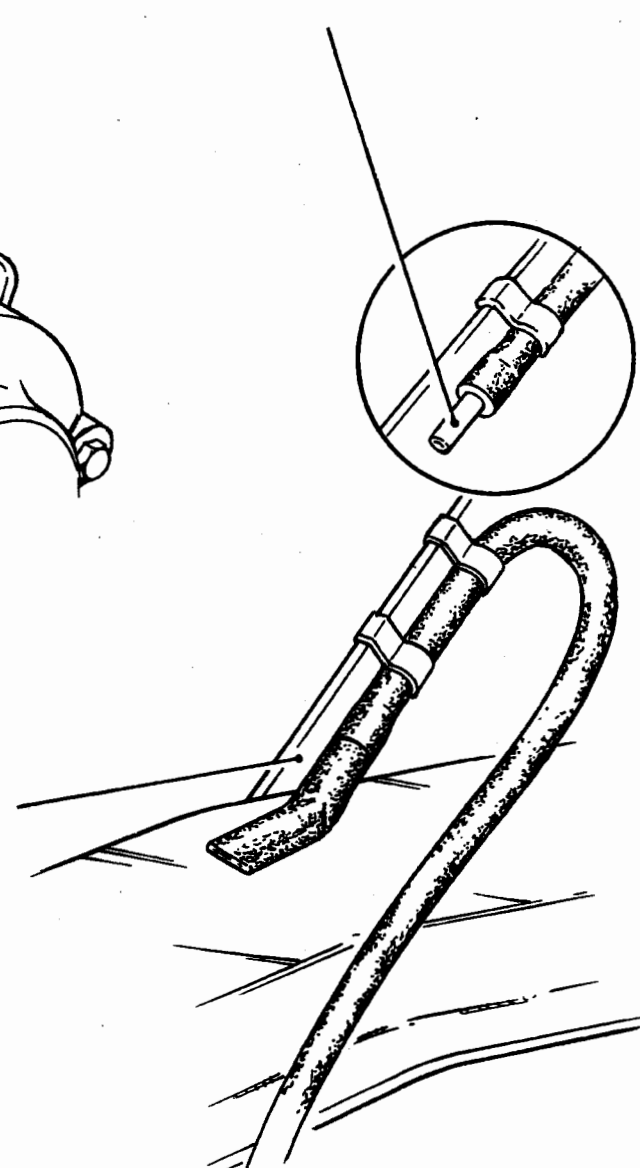

3. Fit a 1/4 in. dia. non-return valve 6WPG 2540 99 817 9523 (WPG 9138) over remaining length of copper tubing, so that non-return valve and breather tube touch.

■ EC-750-C

TASK 60. STEERING BOX BREATHER

1. Cover breather hole with a suitable length of adhesive tape.

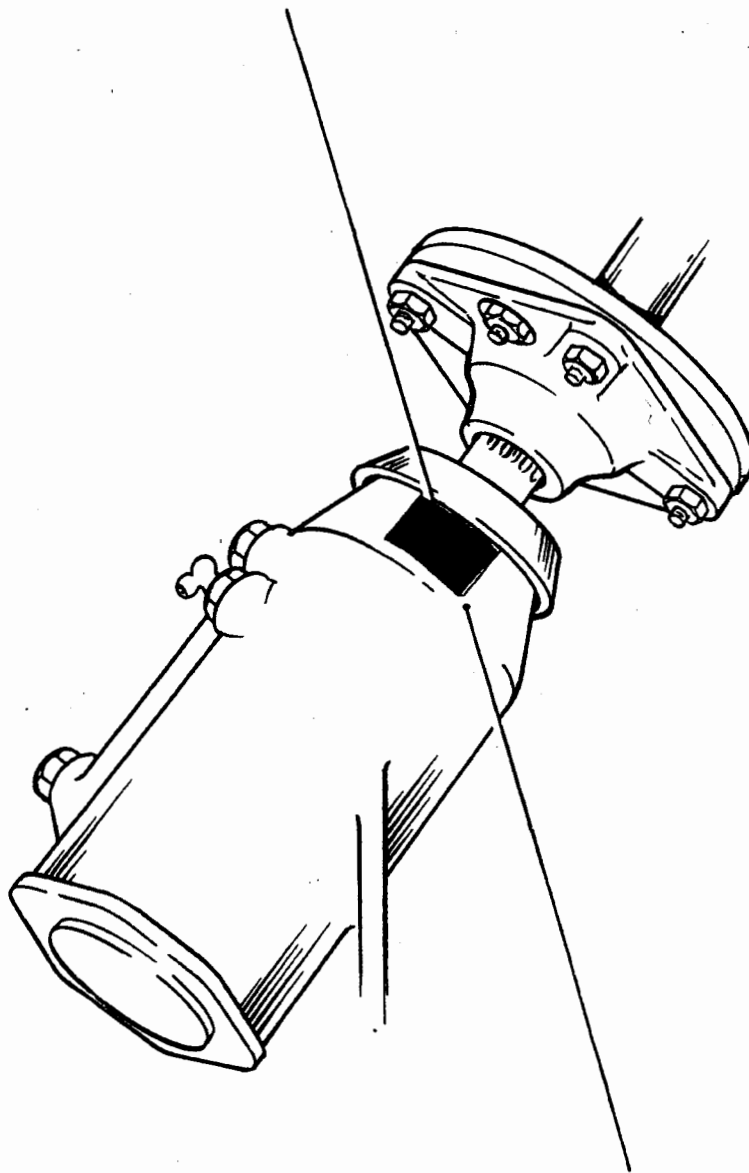

2. Apply an even coat of EC-750-C over taped hole and onto housing.

Note ...

Steering boxes not fitted with breather hole in position shown, have breather hole located underneath rubber shroud. If this type of steering box is fitted, check that steering box is filled completely with lubricating oil. (SEE SERVICING INSTRUCTIONS).

 EC-750-C

TASK 61. BRAKE MASTER CYLINDER RESERVOIRS (2)

1. Top up both reservoirs as necessary.
2. Disconnect fluid level indicator wires from both reservoirs. Cover ends with adhesive tape and secure to front reservoir as shown with a plastic cable strap 6MT4 5340 99 742 6346.

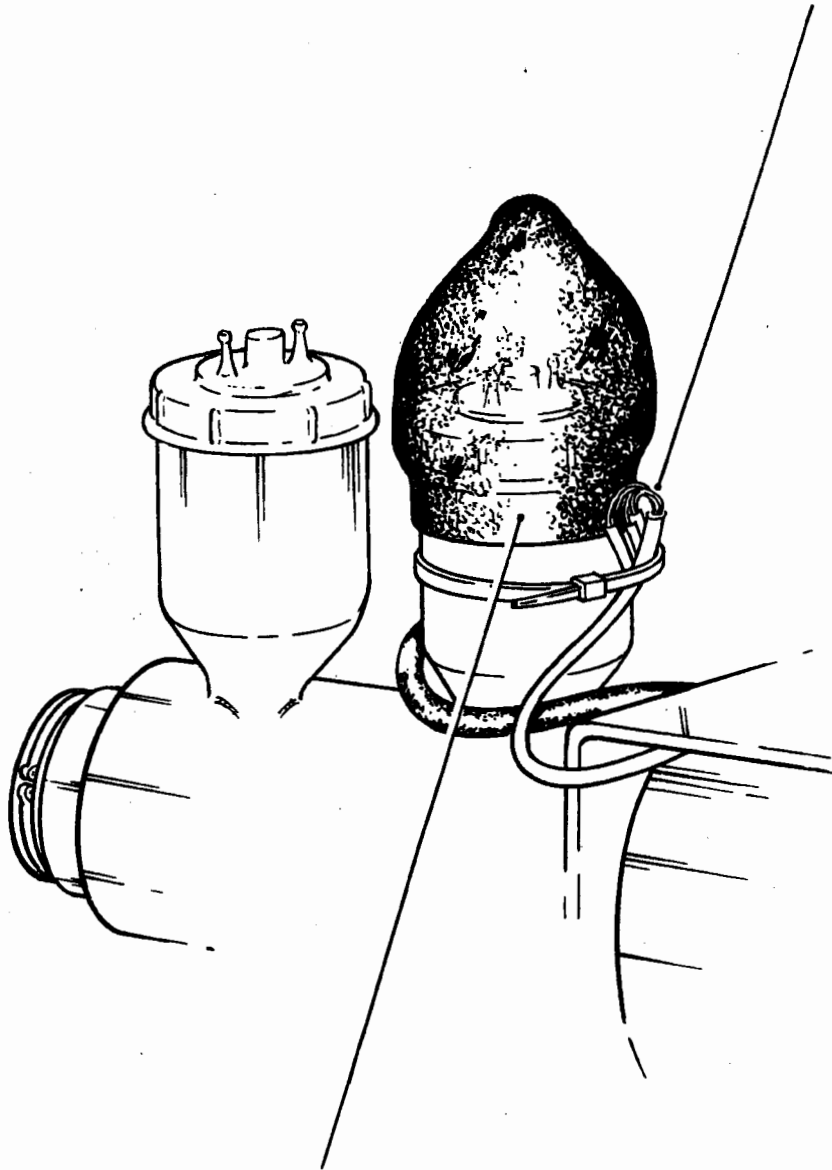

3. Stretch the mouth of rubber cover 6WPG 2540 99 822 3031 (WPG 9184) over each fluid reservoir and position edges of covers on fluid reservoir barrels as shown.

TASK 62. FUEL TANK FILLER - CAP

1. Fill fuel tank to capacity.
2. Stretch mouth of fuel tank filler cover 6WPG 2910 99 823 9601 (WPG 9185) over filler cap and securing chain. Position mouth of cover well below securing chain bracket so that it fits snugly on filler tube neck.

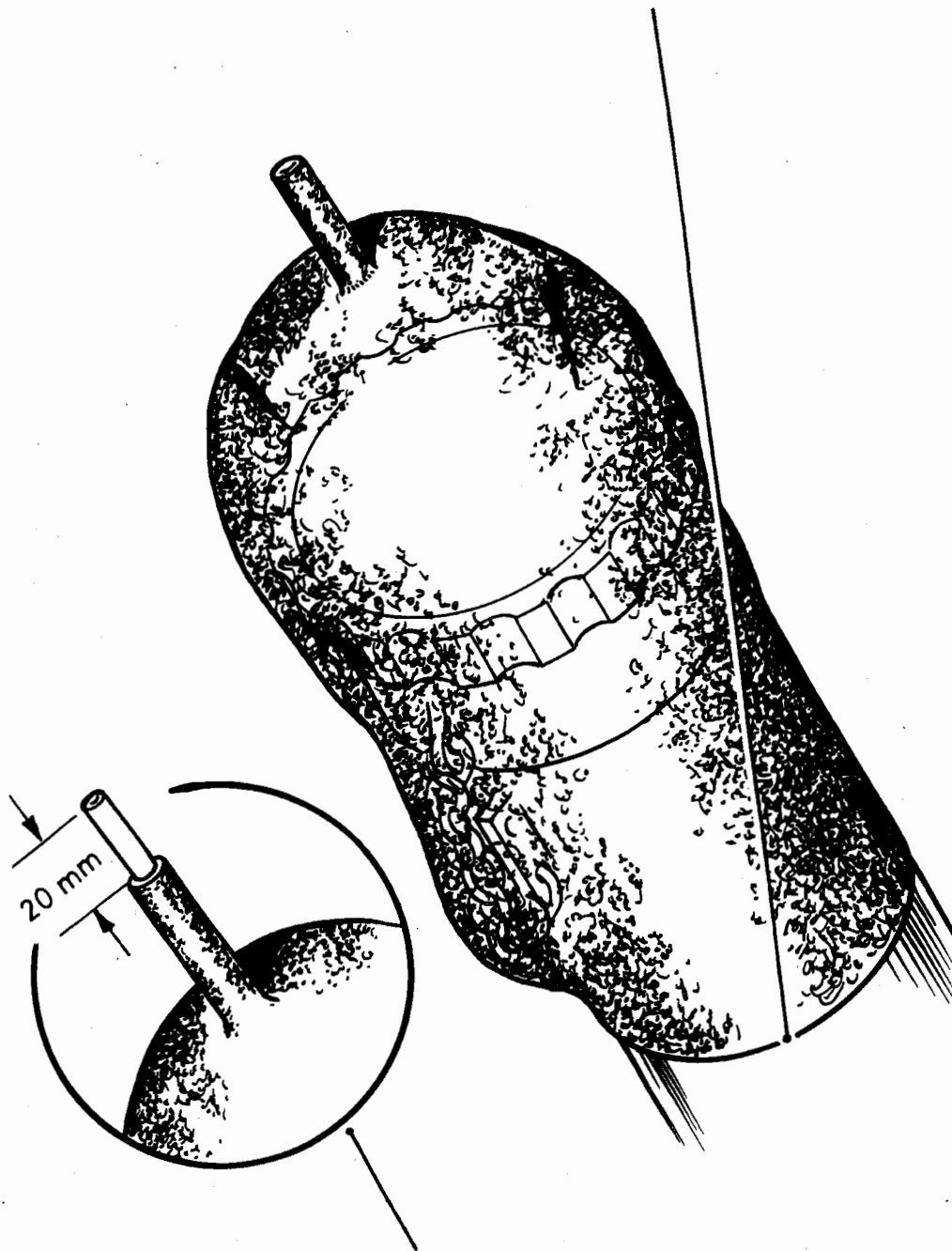

3. Insert a 40 mm length of 5 mm o.d. copper piping G2 4710 99 964 9973 into breather tube on cover until 20 mm remains protruding.

TASK 62. FUEL TANK FILLER CAP (continued)

4. Fit one end of a 1.5 metre length of 5/32 i.d. rubber tubing to copper tubing in cover. The use of a water lubricant will facilitate the fitting of the rubber tubing to the copper insert.
5. Lead rubber tubing up the side of vehicle body and secure at suitable points along its length with polypropylene line.

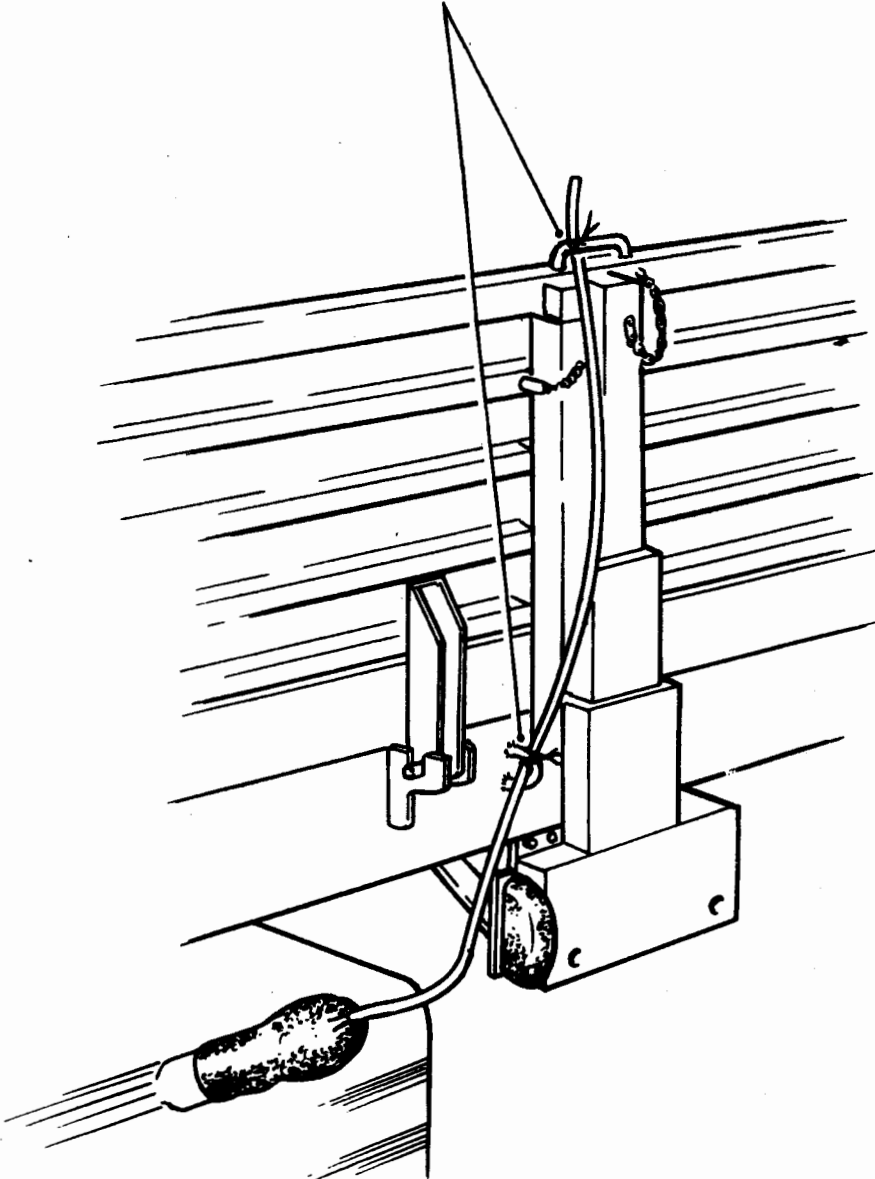

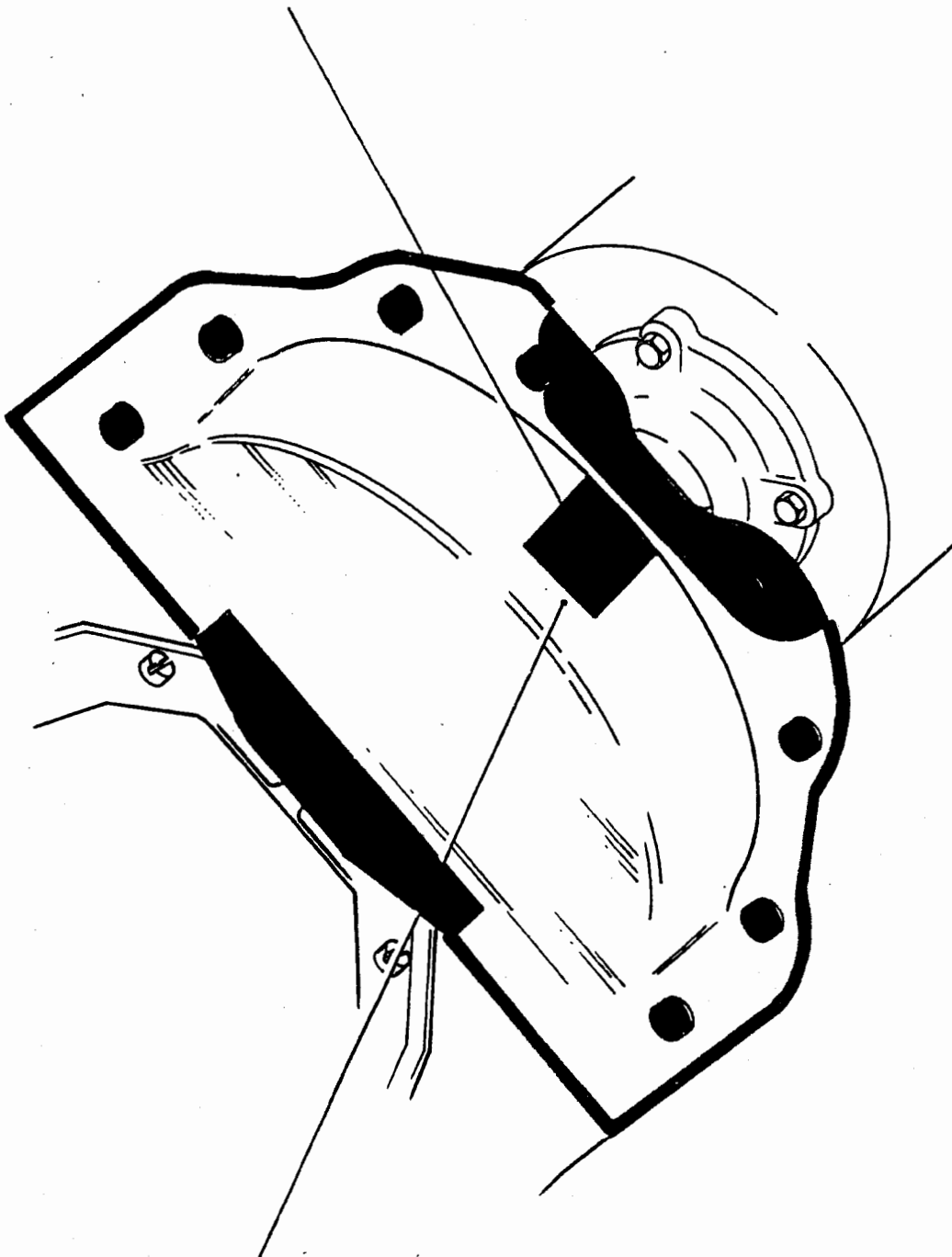

TASK 63. CLUTCH HOUSING DRAIN HOLE

1. Cover clutch drain hole with a 25 mm length of adhesive tape.



2. Mould 40 mm of Prestikon over taped hole.

 Prestikon

 EC-750-C

TASK 64. TYRE INFLATOR UNIT

1. Cover exhauster valve with a 25 mm length of adhesive tape.

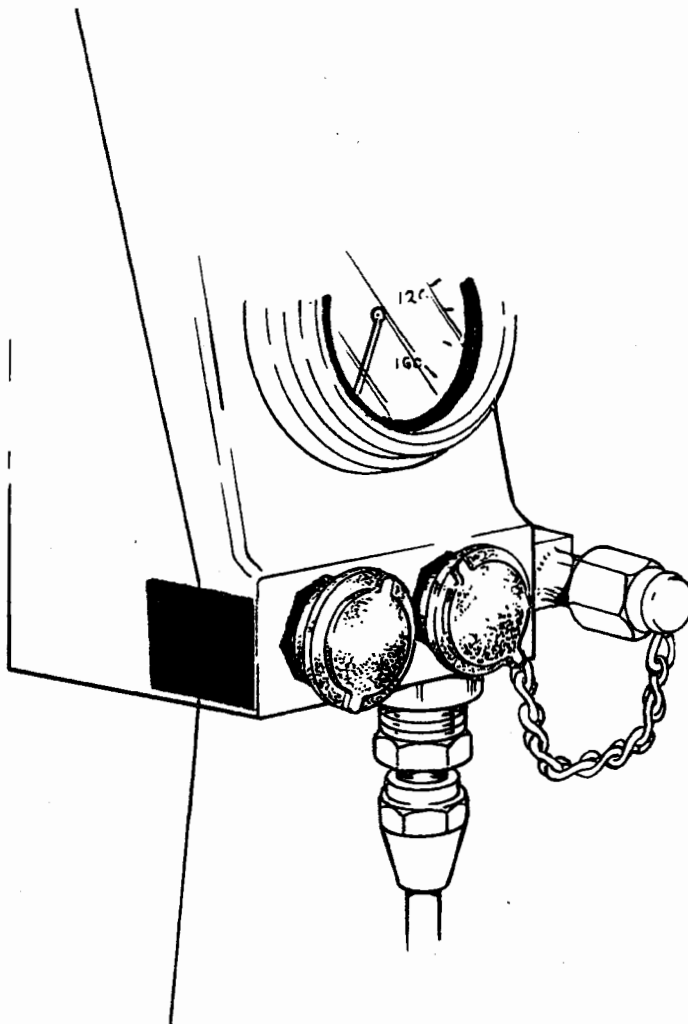

2. Mould a 40 mm length of Prestikon over taped exhauster valve.

■ Prestikon

■ EC-750-C

TASK 65. GENERATOR PLUG AND VOLTAGE REGULATOR

1. Stop engine.
2. Disconnect generator plug.
3. Bind plug with adhesive tape and secure plug in a convenient position.

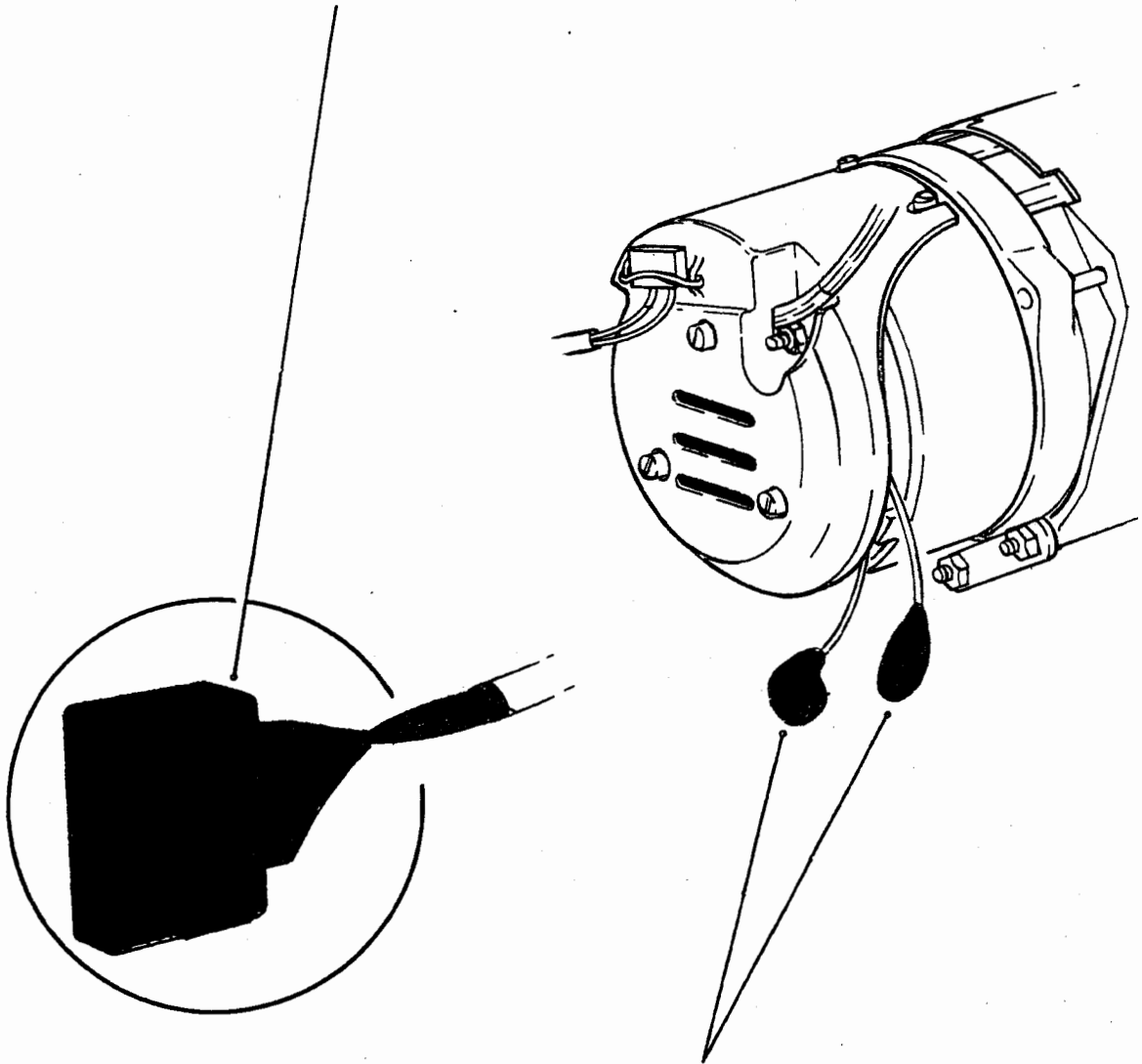

4. Disconnect extension lead (WPG 9376) and tape over terminals of both ends.
5. Fill polythene container 6WPG 2540 99 815 9680 (WPG 9085) with PX 24. Seal container and stow in safe place in the vehicle for use in "Stage C" (Task 72).

 Tape, adhesive

TASK 66. VEHICLE HORNS (2)

1. Disconnect and remove vehicle horns (2) located under each front wing.
2. Cover wiring loom connector under L.H. wing with adhesive tape and secure in a convenient position.
3. Connect lead extension 6WPG 2540 99 819 3427 (WPG 9178) to wiring loom connector under R.H. wing. Cover connection with adhesive tape.
4. Fit both horns to R.H. mirror arm using bracket horn mounting 6WPG 2540 99 819 3426 (WPG 9177) using M6 x 16 mm long screws, 6 mm washers and 6 mm nuts provided in the kit.
5. Connect extension lead (WPG 9178) from under R.H. front wing to the twin terminal on one of the vehicle horns. Secure lead to mirror arm with adhesive tape.

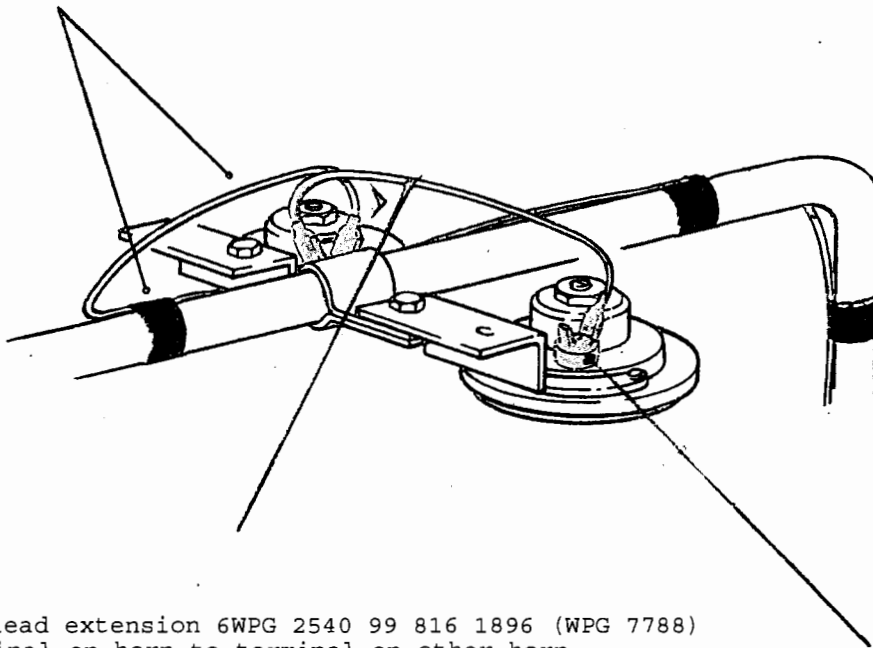

6. Connect lead extension 6WPG 2540 99 816 1896 (WPG 7788) from one terminal on horn to terminal on other horn.
7. Apply a coat of silicone compound over terminals and lead connections to both horns.

■ Tape, adhesive

■ Compound silicone

TASK 66. VEHICLE HORNS (2) (continued)

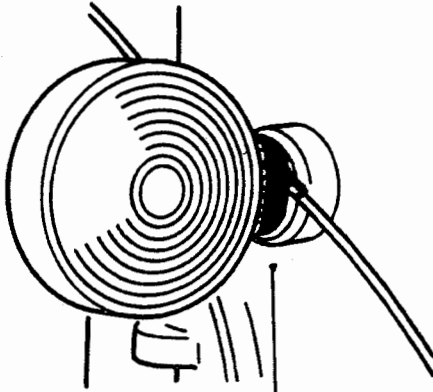

8. Secure extension lead with adhesive tape to turnlight and headlamp guard as shown.

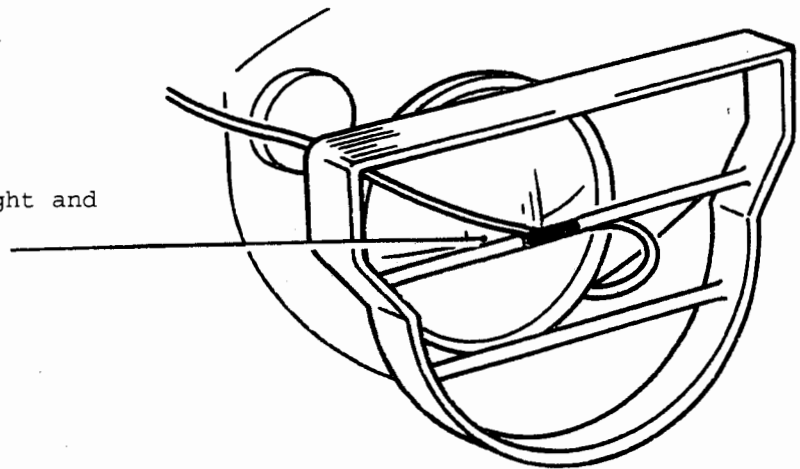

Note ...

Ensure lead is slack enough to allow door to open and close.

 Tape adhesive

TASK 67. AB FLOOR DRAIN HOLES (4)

1. Remove blank caps (2 each side of cab floor) from cab floor and stow in a safe place in the vehicle.

TASK 68. TOWROPE

1. Connect towrope to front towing eye. Take free end up and over windscreen and through co-driver's hatch. Tie one end of remaining length of sisal rope to free end of towrope and tie a suitable weight to other end so that it can be used as a throwing line.

TASK 69. WATERPROOFED EQUIPMENT MARKINGS STAGE B

1. Remove black adhesive tape from the RED Stage B marker as instructed on page 12 of this A.E.S.P.

TASK 70. ITEMS OF EQUIPMENT

1. Place all remaining items of equipment previously removed from vehicle and any vehicle tools or other items of equipment likely to suffer damage due to salt water immersion, into PVC bag(s) and seal with adhesive tape. Stow bag(s) in a safe place on vehicle.

TASK 71. WATERPROOFING A.E.S.P.

1. Memorise tasks in Stage C which must be done as soon as possible after landing. Place this instruction in a PVC bag provided and seal with adhesive tape. Keep instruction in a safe place on your person; it will be required for Stage D.

DRIVING INSTRUCTIONS FOR LEAVING THE CRAFT

Run engine to obtain normal running temperature. Engage second gear, low ratio and four-wheel drive. Approach ramp squarely and drive vehicle as slowly as possible down the ramp. Upon entering water, depress accelerator and drive to beach.

Note ...

IT IS ESSENTIAL TO KEEP VEHICLE MOVING THROUGH THE WATER AS
"LOSS OF WAY" COULD CAUSE FAILURE.

DE WATERPROOFING STAGE C

Note ...

The following Tasks must be carried out within 15 minutes of reaching the beach.

TASK 72. GENERATOR

1. Allow engine to idle.
2. Fit flexible tubing attachment to plastic bottle.
3. Insert flexible tubing into end of rubber tubing extension on adaptor, slipping housing. Inject PX-24 from bottle into slipping housing.

DO NOT UNDER ANY CIRCUMSTANCES RECONNECT GENERATOR UNTIL ABOVE TASK IS COMPLETED OR WHILST ENGINE IS RUNNING.

TASK 73. COMMERCIAL TYPE BATTERIES

1. Stop engine.
2. Remove battery main cover.
3. Remove Prestikon around each filler cover on top of each battery.
4. Refit battery main cover.

TASK 74. GENERATOR CONNECTIONS

1. Remove adhesive tape from generator plug and reconnect plug to generator.
2. Remove adhesive tape from end of extension lead ends, reconnect extension lead terminals together.
3. Run engine and check that generator is charging.

TASK 75. CLUTCH HOUSING DRAIN HOLE

1. Unseal clutch housing drain hole.

TASK 76. TYRE INFLATOR EXHAUST VALVE

1. Remove Prestikon and tape from exhaust valve.

TASK 77. BRAKE MASTER CYLINDER LEAKAGE VENT

1. Remove rivet from rubber tubing, keep rivet in a safe place in the vehicle.

TASK 78. CAB FLOOR DRAIN HOLES

1. Refit blank rubber grommets into holes in cab floor.

TASK 79. WATERPROOFED EQUIPMENT MARKINGS STAGE C

1. Cover the RED Stage B marker with black adhesive tape as instructed on page 12 of this A.E.S.P.

WET SHOD RE-EMBARKATION.SUMMARY

This instruction details action to be taken when the vehicle will wet-shod re-embark on the landing craft after disembarking operations have been completed.

RE-EMBARKATION

1. Check all oils for water contamination as detailed in Stage D.
2. Carry out a thorough check of all waterproofing carried out in Stages A and B and rectify any damage.
3. Carry out Tasks 55, 56, 63, 64, 65, 67 and 69.
4. Top up vehicle fuel tank; refit filler cover and breather tubing.

DE-WATERPROOFING STAGE D

Note ...

Task 80 and 81 must be carried out within 25 miles from point of disembarkation if operationally possible. The remainder should be carried out as soon as conditions permit.

TASK 80. OIL CHANGE

1. Check all oils. If water is present in any assembly:-
 - 1.1 Drain off.
 - 1.2 Refill with correct grade lubricant.

TASK 81. CLUTCH AND BRAKES

1. To prevent seizure of clutch and brakes when parked, every opportunity should be taken to:-
 - 1.1 Prop out clutch pedal with a suitable prop.
 - 1.2 Chock road wheels and leave handbrake OFF.

Note ...

If vehicle is used on training exercise only, hubs and brakes should be stripped and serviced at earliest opportunity to reduce long-term effect of salt water corrosion.

TASK 82. WASH DOWN

1. Wash down vehicle and equipment thoroughly with fresh water. Remove all traces of sand and salt deposits.

TASK 83. LUBRICATION

1. Carry out complete lubrication of vehicle and equipment as detailed in Servicing Schedule.

TASK 84. GENERATOR

THIS TASK TO BE CARRIED OUT WITH THE ASSISTANCE OF A VEHICLE MECHANIC.

1. Remove and service generator paying particular attention to sliprings and brush gear.

TASK 85. CAB HEATER

THIS TASK TO BE CARRIED OUT WITH THE ASSISTANCE OF A VEHICLE MECHANIC.

1. Refit cab heater assembly; reconnect wiring leads and hoses.
2. Stow 50 mm length of copper tubing with other waterproofing materials previously stowed in vehicle.

DE-WATERPROOFING STAGE D (continued)TASK 86. FRONT AND REAR AXLE BREATHERS (2)

1. Remove front and rear non-return valves from breather pipes. Stow non-return valves in a safe place in the vehicle.

TASK 87. TRANSFER BOX BREATHER

1. Remove non-return valve complete with 50 mm length of copper pipe from transfer box breather pipe. Stow items in a safe place in the vehicle.

TASK 88. STEERING BOX BREATHER

1. Remove adhesive tape covering breather hole.

TASK 89. BRAKE MASTER CYLINDER RESERVOIRS (2)

1. Remove rubber covers from each fluid reservoir. Stow covers in a safe place in the vehicle.
2. Reconnect electrical leads to both reservoirs.

TASK 90. FUEL TANK FILLER CAP

1. Remove filler cover and breather tubing. Stow cover and tubing in a safe place in the vehicle.

TASK 91. TYRES

1. Inflate tyres to normal road pressure as and when necessary.

Front 45 P.S.I.

Rear 91 P.S.I.

TASK 92. HORN

1. Disconnect horn extension leads and stow in a safe place in the vehicle.
2. Remove horns from mirror arm and refit to mountings under front wings. Reconnect original wiring loom connectors to horn terminals.
3. Stow horn mounting bracket in a safe place in the vehicle.

Note ...

In the event of complete de-waterproofing of vehicle, grommets blank rubber (2) 6MT1 5325 99 812 0266 are provided for fitting in holes used for securing air intake extension to rear of cab.

TABLE 3 - SUPERVISOR'S CHECK LIST
TRUCK CARGO BEDFORD MJP 4 TONNE 4 x.4

VEHICLE NO

Page No	Task No	Item	Initialed completed
<u>WATERPROOFING STAGE A</u>			
14	1	Batteries (2)	
14	2	Removal of items of equipment	
15	3	Generator	
19	4	Clutch housing	
25	5	Clutch operating lever	
28	6	Starter motor	
30	7	Gear lever	
31	8	Speedometer cable	
32	9	Brake condensing reservoir	
33	10	Triple system protection valve	
34	11	Brake relay valve	
35	12	Air pressure loss limiting valve	
36	13	Compressor governor valve	
37	14	Load sensing valve	
39	15	Footbrake valve	
40	16	Brake master cylinder actuator	
45	17	Stop lamp switches	
46	18	Rubber elbow connections	
47	19	Engine crankcase breather (earlier type vehicle)	
48	20	Engine crankcase breather (later type vehicle)	
49	21	Engine oil filler cap and breather (earlier type vehicle)	
50	22	Engine oil filler cap and breather (later type vehicle)	
51	23	Engine oil dipstick (earlier type vehicle)	

TABLE 3 SUPERVISOR'S CHECK LIST (continued)

Page No	Task No	Item	Initialled completed
52	24	Engine oil dipstick (later type vehicle)	
53	25	Cold start solenoid and heater plugs	
54	26	Fuel lift pump	
55	27	Tachometer	
58	28	Trailer brake emergency switch, (early type)	
61	29	Trailer brake emergency switch, (later type)	
64	30	Hand brake lever indentation	
65	31	Thermostart relay, circuit breaker, ballast resistor	
68	32	Ignition and thermostart switches	
75	33	Air filter, Cooper type	
81	34	Air filter, AC type	
87	35	Securing of breather hoses (4)	
88	36	Windscreen washer motor and windscreen wiper motor suppressor	
89	37	Battery master switch	
91	38	Tyre inflator unit	
93	39	Fuel tank sender unit	
94	40	Turnlights front (2)	
95	41	Trailer sockets - 2 and 12 pin	
96	42	Rear air palm couplings (2)	
97	43	Engine oil pressure warning switch	
98	44	Low air pressure warning switches (2)	
99	45	Temperature gauge switch	
100	46	Fuel injection pump	
101	47	Instrument panel and wiper motor etc.	
101	48	Preservation	

TABLE 3 SUPERVISOR'S CHECK LIST (continued)

Page No	Task No	Item	Initialled completed
101	49	Refitting items of equipment	
102	50	Functional check of equipment	
102	51	Waterproofed equipment markings stage A	
102	52	Waterproofing materials for Stage B	
		<u>WATERPROOFING STAGE B</u>	
103	53	Check of waterproofing completed in Stage A	
103	54	Deflate tyres to cross country pressures	
103	55	Brake master cylinder leakage vent	
103	56	Commercial type batteries	
104	57	Heater assembly	
105	58	Front and rear axle breathers (2)	
106	59	Transfer box breather	
107	60	Steering box breather	
108	61	Brake master cylinder reservoirs (2)	
109	62	Fuel tank filler cap	
111	63	Clutch housing drain hole	
112	64	Tyre inflator unit	
113	65	Generator plug and voltage regulator	
114	66	Vehicle horns (2)	
116	67	Cab floor drain holes (4)	
116	68	Towrope	
116	69	Waterproofed equipment markings Stage B	
116	70	Items of equipment	
116	71	Waterproofing A.E.S.P.	
		<u>DE-WATERPROOFING STAGE C</u>	
117	72	Generator	
117	73	Commercial type batteries	

TABLE 3 SUPERVISOR'S CHECK LIST (continued)

Page No	Task No	Item	Initialled completed
		<u>DE WATERPROOFING STAGE C (continued)</u>	
117	74	Generator connections	
117	75	Clutch housing drain hole	
117	76	Tyre inflator exhaust valve	
117	77	Brake master cylinder leakage vent	
117	78	Cab floor drain holes	
117	79	Waterproofed equipment markings Stage C	
118	-	Wet Shod re-embarkation	
		<u>DE-WATERPROOFING STAGE D</u>	
119	80	Oil change	
119	81	Clutch and brakes	
119	82	Wash down	
119	83	Lubrication	
119	84	Generator	
119	85	Cab heater	
120	86	Front and rear axle breathers (2)	
120	87	Transfer box breather	
120	88	Steering box breather	
120	89	Brake master cylinder reservoirs (2)	
120	90	Fuel tank filler cap	
120	91	Tyres	
120	92	Horn	

END

FOR OFFICIAL USE ONLY
CROWN COPYRIGHT RESERVED



TRUCK, 4 TONNE, 4x4, BEDFORD MJ - ALL VARIANTS

INSPECTION STANDARD PART 1

COMPLETE EQUIPMENT

REPRINTED INCORPORATING AMDTS 1-3

This publication contains information covering the requirements of Sub-Category 5-3 at information levels 2 and 3

BY COMMAND OF THE DEFENCE COUNCIL

Sponsor:

DGEME (A) EME 7b

File ref: D/DGEME/125/8/16

Alive Whitmore.

Ministry of Defence

Publications Authority:

Vehicles & Weapons Branch REME

Project No: 7b/1067 (120)

File ref: 7b/1067/AESP/B

AMENDMENT RECORD

Amdt	Incorporated by	Date	Amdt	Incorporated by	Date
1	Incorporated		7		
2	Theresa Brooks	25.5.98	8		
3	Theresa Brooks	18.11.98	9		
4			10		
5			11		
6			12		

INSPECTION STANDARD PART 1

EQUIPMENT IDENTITY

1 The equipments included are:

1.1 MJP2BMO vehicles all variants with turbo-charged 330 cu in.
(5.4 litre) engine.

INTRODUCTION

2 Except for manuscript entries, amendments are identified by marginal side lining. Manuscript amendments are identified by Amdt No in outside margin in line with the amendment.

3 Comments on this publication are to be forwarded in accordance with AESP 0100-P-011-013 to Vehicles and Weapons Branch REME, Chobham Lane, Chertsey, Surrey KT16 0EE.

4 This publication details the Acceptable Quality Levels (AQL) for the complete equipment to meet the quality standard at levels 2 and 3.

5 It is to be applied in conjunction with the general principles contained in Chapter 150 of EMER T & M A 028.

6 The following abbreviations are used: H = High L = Low

INDEX TO SCHEDULES

7 Main breakdown of inspection and testing of complete equipment is as follows:

- 1 Engine
- 2 Clutch
- 3 Gearbox
- 4 Transfer box
- 5 Rear axle
- 6 Front axle
- 7 Steering
- 8 Suspension
- 9 Brakes
- 10 Road Test
- 11 Crane

<u>Fig</u>	<u>Page</u>
1 Atlas Crane Overload Test Kit	10

7c 1147(212) D2-1-22-11

SCHEDULE

8 This schedule gives the AQL, for inspection and testing of complete equipment at levels 2 and 3.

Ser	Detail	Acceptable Quality Level (AQL)		Remarks
		Level 2	Level 3	
(1)	(2)	(3)	(4)	(5)
1	<u>ENGINE</u>			
	1.1 Compression pressure at starter cranking speed, normal operating temperature, all injectors removed.	H. 33.8 bar (490 lbf/in ²) L. 23.4 bar (340 lbf/in ²)	L. 26.2 bar (380 lbf/in ²)	
	1.2 Maximum variation between cylinders:	2.07 bar (30 lbf/in ²)		
	1.3 Fan belt adjustment remaining (belt at correct tension):	H. 8.9 mm (3/4 in.) L. 12.5 mm (1/2 in.)	L. 25 mm (1 in.)	Measured at slot of alternator bracket
	1.4 Rock at tip of fan blades:	H. 3.2 mm (1/8 in.) L. 0.000	H. 0.8 mm (1/32 in.)	
	1.5 Lubricating oil pressure (hot) at 2000 rev/min.	See remarks	H. 3.4 bar (50 lbf/in ²) L. 2.0 bar (30 lbf/in ²)	Oil warning light to be out at idling speed
	1.6 Engine, hot, to idle smoothly at:	500/550 rev/min		
	1.7 Coolant temperature (maximum):	95°C		
	1.8 Maximum governed speed at full load (rev/min).	2700		Maximum eng no load speed 2970 rev/min.
2	<u>CLUTCH</u>			
	2.1 Clutch pedal free travel:	25 mm (1 in.)		

(continued)

SCHEDULE (continued)

(1)	(2)	(3)	(4)	(5)
3	<p><u>GEARBOX</u></p> <p>3.1 Backlash measured at rim of output flange:</p> <p>3.2 Lift at output flange:</p>	<p>H 16 mm (5/8 in.)</p> <p>L 6 mm (1/4 in.)</p> <p>H 2.4 mm (3/32 in.)</p> <p>L ZERO</p>	<p>H 9.5 mm (3/8 in.)</p> <p>H 1.6 mm (1/16 in.)</p>	
4	<p><u>TRANSFER BOX</u></p> <p>4.1 Backlash measured at rim of output flanges to front and rear axle:</p> <p>4.2 Lift at output flange:</p> <p>4.3 Backlash measured at rim of input flange:</p> <p>4.4 Lift at input flange:</p>	<p>H 16 mm (5/8 in.)</p> <p>L 6 mm (1/4 in.)</p> <p>H 2.4 mm (3/32 in.)</p> <p>L ZERO</p> <p>H 16 mm (5/8 in.)</p> <p>L 6 mm (1/4 in.)</p> <p>H 2.4 mm (3/32 in.)</p> <p>L ZERO</p>	<p>H 9.5 mm (3/8 in.)</p> <p>H 1.6 mm (1/16 in.)</p> <p>H 9.5 mm (3/8 in.)</p> <p>H 1.6 mm (1/16 in.)</p>	
5	<p><u>REAR AXLE</u></p> <p>5.1 Lift at input flange:</p> <p>5.2 Backlash measured at rim of wheel (input held):</p>	<p>H 2.4 mm (3/32 in.)</p> <p>L ZERO</p> <p>H 63.5 mm (2½ in.)</p> <p>L 16 mm (5/8 in.)</p>	<p>H 1.6 mm (1/16 in.)</p> <p>H 50.8 mm (2 in.)</p>	
6	<p><u>FRONT AXLE</u></p> <p>6.1 Lift at input flange:</p> <p>6.2 Backlash measured at rim of wheel (input held):</p> <p>6.3 Wheel hub rim rock (no perceptible clearance in swivel pin)</p>	<p>H 2.4 mm (3/32 in.)</p> <p>L ZERO</p> <p>H 63.5 mm (2½ in.)</p> <p>L 16 mm (5/8 in.)</p> <p>H 4.8 mm (3/16 in.)</p> <p>L 1.6 mm (1/16 in.)</p>	<p>H 1.6 mm (1/16 in.)</p> <p>H 50.8 mm (2 in.)</p> <p>H 2.4 mm (3/32 in.)</p>	(continued)

SCHEDULE (continued)

(1)	(2)	(3)	(4)	(5)
7	<p><u>Steering</u></p> <p>7.1 Toe in measured at wheel rim:</p> <p>7.2 Free play measured at steering wheel rim:</p> <p>7.3 Turning circle</p>	<p>1.52 mm to 4.57 mm (1/16 in. to 3/16 in.)</p> <p>H 101.6 mm (4 in.)</p> <p>L 12.7 mm (1/2 in.)</p> <p>18.01 m (60 ft)</p>	<p>H 63.5 mm (2 1/2 in.)</p>	
8	<p><u>SUSPENSION</u></p> <p>8.1 Camber of semi-elliptic springs</p> <p>Front:</p> <p>Rear:</p> <p>8.2 Lift at shackle pins</p>	<p>L 12.7mm (1/2 in.)</p> <p>L 19 mm (3/4 in.)</p> <p>H 2.4 mm (3/32 in.)</p>	<p>H 25.4 (1 in.)</p> <p>H 49.8 mm (2 in.)</p> <p>L 16mm (5/8 in.)</p> <p>L 25.4 mm (1 in.)</p> <p>H 1.6 mm (1/16 in.)</p> <p>L 0.8 mm (1/32 in.)</p>	
9	<p><u>BRAKES</u></p> <p>9.1 Free movement at top of brake pedal:</p> <p>9.2 Thickness of brake linings, front and rear:</p> <p>Leading:</p> <p>Trailing:</p> <p>9.3 Compressor governor valve settings:</p> <p>Cut-out pressure:</p> <p>Cut-in pressure:</p>	<p>H 12.3 mm (1/2 in.)</p> <p>H 6.7 mm (17/64 in.)</p>	<p>25.4 mm (1 in.)</p> <p>L 8.0 mm (5/16 in.)</p> <p>L 4.8 mm (3/16 in.)</p> <p>7.4 Bar (107 lbf/in²)</p> <p>6.1 Bar (88 lbf/in²) (Min)</p>	(continued)

72211(298)
ATSA Chertsey

9802\NTCP-1202
Feb 98 (Amdt 2)

SCHEDULE (continued)

(1)	(2)	(3)	(4)	(5)
	<p>9.4 Condensing tank safety valve setting:</p> <p>9.5 Brake system warning switch Makes contact: Breaks contact:</p> <p>9.6 Air pressure stop lamp switch Cut-in pressure:</p> <p>9.7 Permissible leakage rate With all brakes released (handbrake on): With all brakes applied (handbrake on):</p>	<p>9.6 Bar-10 Bar (140 lbf/in² - 150 lbf/in²)</p> <p>5.34 Bar-4.66 Bar (78 lbf/in²) - (68 lbf/in²)</p> <p>4.66 Bar-5.34 Bar (68 lbf/in²) - (78 lbf/in²)</p> <p>0.4 Bar (6 lbf/in²)</p> <p>0.35 Bar (5 lbf/in²) in 5 min</p> <p>0.7 Bar (10 lbf/in²) in 5 min</p>	<p>0.35 Bar (5 lbf/in²) in 10 min</p> <p>0.7 Bar (10 lbf/in²) in 10 min</p>	
<p>10</p>	<p><u>ROAD TEST</u></p> <p>10.1 Oil consumption</p> <p>10.2 Time to accelerate from 20 to 40 mile/h in top gear:</p> <p>10.3 Braking efficiency minimum requirement must be achieved:</p> <p>10.4 Distance to pull up on dry level surface from 20 mile/h given minimum braking efficiency:</p> <p>10.5 Handbrake to hold on a gradient of:</p> <p>10.6 Hill holder brake (not lockable) to hold vehicle on a gradient of:</p>	<p>370 Km/L (130 mile/pt)</p> <p>H 30 sec</p> <p>L 15 sec</p> <p>50% (Min)</p> <p>7.62 m (25 ft) (Max)</p> <p>1 : 4</p> <p>1 : 4</p>	<p>425 Km/L (150 mile/pt)</p> <p>H 25 sec</p>	<p>Cargo vehicle unladen with full tank of fuel.</p>

SCHEDULE (continued)

(1)	(2)	(3)	(4)	(5)
11	<u>CRANE</u>			
	11.1 Working pressure system relief valve set to:	RAF VEHICLES 150 BAR (2175 lbf/in ²) nominal		Check with engine at 1200 rev/min
		ARMY VEHICLES 200 BAR (2900 lbf/in ²) nominal		
	11.2 Ram creep limit (total creep of lifting and jib rams)	75 mm max over 5 min period		
	11.3 Stabilizer ram creep:	zero		Stabilizer ram shut off valve to be in closed position
	11.4 SWL Test	To just lift SWL		In accordance with para 10
	11.5 Proof load test	No distortion, cracks flaking paint or hydraulic fluid leaks		In accordance with para 12

HYDRAULIC CRANE TESTS

WARNINGS ...

- (1) TESTING OF THE CRANE IS TO BE CARRIED OUT BY AUTHORIZED PERSONNEL.
- (2) TESTS ARE TO BE CARRIED OUT IN A NOMINATED CRANE TESTING AREA CLEARED OF PERSONNEL AND OBSTRUCTIONS.

CAUTIONS

- (1) The Overload Test Kit which is the subject of this instruction must not be used on cranes fitted with remote control facility.
- (2) Cranes fitted to Army vehicles operate with a system pressure of 200 bar. RAF vehicles 150 bar.

9 PREPARATION

9.1 To prepare the crane for craning operations refer to 'operating the crane' in operating information AESP 2320-H-100-201 Chapter 3.2.

PROOF LOAD TESTCAUTION ...

Before carrying out the Proof Load Test ensure that system pressure relief valve is set to lift the Safe Working Load (SWL)

10

10.1 Check the system pressure in accordance with AESP 2320-H-100-522 Chap 18 para 10-12 using 9AHY/6685-99-826-8090 Gauge Pressure c/w connection.

10.2 Reduce system pressure to 130 bar (1885 lbf/in²) (RAF) 180 bar (2610 lbf/in²) Army.

10.3 Using the figures on the crane duty plate jib out to the maximum radius shown and attempt to lift the associated load.

10.4 Increase the system pressure by degrees to a maximum of 160 bar (RAF) 210 bar (Army) until the load is lifted.

10.5 If with the system relief valve set to 160 bar (RAF) 210 (Army) the load is not lifted, check the operating pressures of the jib and boom relief valves in accordance with AESP 2320-H-100-522 Chap 18 paras 13-22 for RAF or EMER Eng & Misc U 124/3 Chap 2 for Army vehicles.

11 The proof load is 1.25 x SWL and the extra lift capability is achieved hydraulically by the introduction of an Overload Test Kit (Fig 1) into the return line from the control valve to the hydraulic reservoir.

CAUTIONS ...

- (1) Before use, ensure that the test kit PRV is set to operate at 80 bar by connecting the test kit to a hand driven hydraulic pump fitted with a suitable gauge.
- (2) Ensure that the hand pump is clean and that it is charged with the same hydraulic oil as the crane being tested.
- (3) Ensure, when fitting the test kit to the crane hydraulic system that the outlet union from the test kit PRV is connected to the fluid line to the crane system reservoir.

12

12.1 Remove the hydraulic pipe from the control valve to the hydraulic reservoir.

12.2 Fit the test kit, using the flexible hoses provided, between the control valve and the reservoir. Ensure the outlet hose from the test kit pressure relief valve goes to the reservoir.

12.3 Ensure that the shut-off valve (Fig 1 item 3) in the test kit circuit is open.

CAUTION ...

Ensure load is correct for chosen radius.

12.4 Using the figures on the crane duty plate jib out to the maximum radius shown and close the shut-off valve in the test kit.

12.5 Add weights to increase the Safe Working Load (SWL) at that radius by 25%.

12.6 Lift the load and slew the crane through its full range of travel.

12.7 Lower the load and remove the test weight.

12.8 Closely examine the crane structure and hydraulic system for deformities, cracking or flaking paintwork and hydraulic leaks.

12.9 Jib in to the intermediate radius of the crane stated on the duty table.

12.10 Using a test weight 25% in excess of that stated for SWL, lift the load and slew the crane through its full range of travel.

12.11 Lower the load and remove test weight and again closely examine the crane structure for deformities, cracks or flaking paint and the hydraulic system for leaks.

12.12 Jib in to minimum radius of the crane stated on the duty table.

12.13 Using a test weight 25% in excess of that stated for SWL lift the load and slew the crane through its full range of travel.

12.14 Lower the load and remove test weight and check crane for faults as in para 12.11.

12.15 Open the shut-off valve on the test kit.

12.16 Remove the test kit and re-connect hydraulic pipe from the control valve to the reservoir.

13 Before returning the crane to the user, re-check the SWL in accordance with para 10 and include in the check, the load decelerating valves, which can be proved as follows:

13.1 Whilst lowering the SWL at full speed arrest the load suddenly, this will check the functioning of the load decelerating valves.

13.2 Again examine the crane for any faults as at para 12.11.

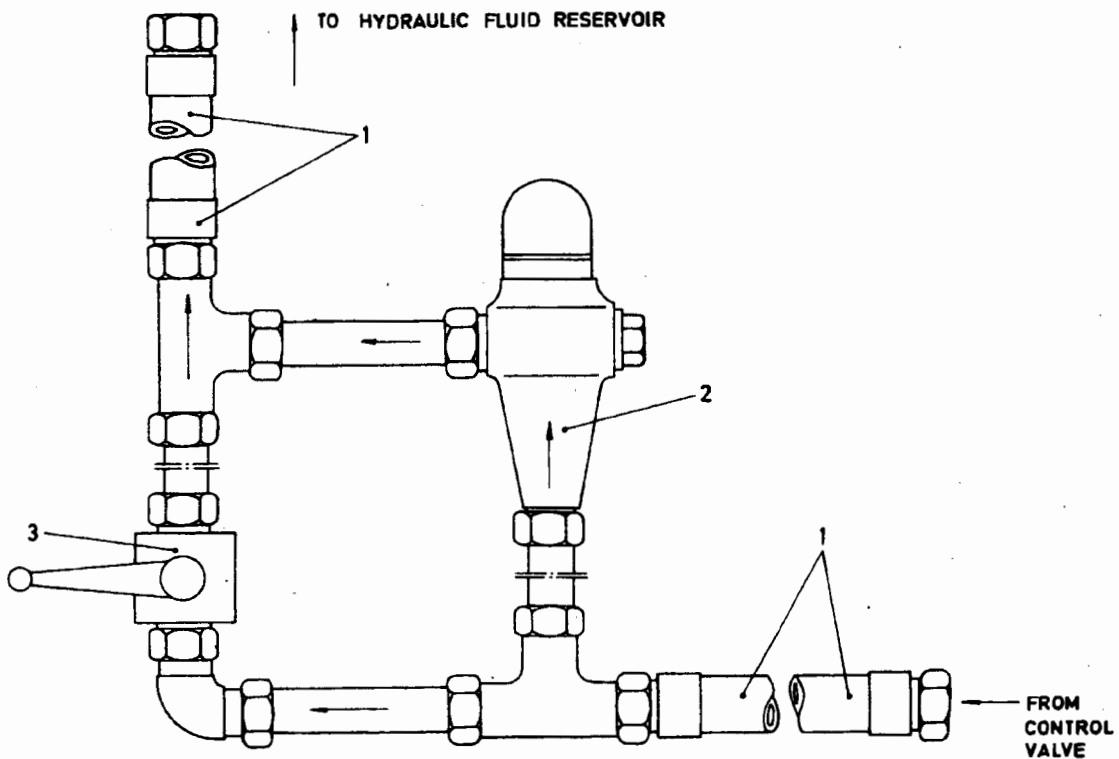

- 1. Hose NW 16 X 1000 mm
- 2. Pressure Relief Valve (To be set to 80 bar)
- 3. Shut-off cock

V6976/1

Fig 1 - Overload Test Kit (Atlas)
(Atlas Part No 306.24.69)
(NATO Code NYA)

~~FOR OFFICIAL USE ONLY~~
~~CROWN COPYRIGHT RESERVED~~



TRUCK, 4 TONNE, 4x4, BEDFORD MJ - ALL VARIANTS

INSPECTION STANDARD PART 2

EXAMINATION AND TESTING OF COMPONENTS AND ASSEMBLIES

This publication contains information covering the requirements of Sub-Category 5-3 at information levels 3 and 4

BY COMMAND OF THE DEFENCE COUNCIL

Sponsor:

DGEME(A) EME 7b

File ref: D/DGEME/125/8/16

Miss Whitmore.

Publications Authority:

Vehicles & Weapons Branch REME

Project No: 7b/1067(108)

File ref: 7b/1067/AESP/B

Ministry of Defence

AMENDMENT RECORD

Amdt	Incorporated by	Date	Amdt	Incorporated by	Date
1			7		
2			8		
3			9		
4			10		
5			11		
6			12		

INSPECTION STANDARD PART 2

EQUIPMENT IDENTITY

1 The equipments included are:

1.1 MJP2BMO vehicles all variants with turbo-charged 330 cu in.
(5.4 litre) engine.

INTRODUCTION

2 Except for manuscript entries, amendments are identified by marginal side lining. Manuscript amendments are identified by Amdt No in outside margin in line with the amendment.

3 Comments on this publication are to be forwarded in accordance with AESP 0100-P-011-013 to Vehicles & Weapons Branch REME, Chobham Lane, Chertsey, Surrey KT16 0EE.

SCHEDULES

4 For Inspection Standard Part 2 details of engine, refer to AESP 2815-K-062-533. For details of other assemblies, reference should be made to manufacturers' limits and tolerances specified in AESP 2320-H-100-522 and AESP 2320-H-100-523.

~~FOR OFFICIAL USE ONLY~~
~~CROWN COPYRIGHT RESERVED~~

The information within this publication
is released by the UK Government to the
recipient in accordance with the
Conditions of Release given at
Page/Frame (ii)



TRUCK, 4 TONNE, 4x4, BEDFORD MJ (ALL VARIANTS)

GENERAL INSTRUCTIONS

BY COMMAND OF THE DEFENCE COUNCIL

Sponsor:

W. E. G. J. G. J.

Ministry of Defence

Publications Authority:
Vehs & Wpns Br REME
Project No: 71511(48)
File ref: 30901/31

CONDITIONS OF RELEASE

- ~~1. This information is released by the UK Government for defence purposes only.~~
- ~~2. This information must be accorded the same degree of security protection as that accorded thereto by the UK Government.~~
- ~~3. This information may be disclosed only within the Defence Departments of the recipient government, except as otherwise authorized by Ministry of Defence (Army).~~
4. This information may be subject to privately owned rights.

AMENDMENT RECORD

Amdt	Incorporated by	Date
1		
2		
3		
4		
5		
6		
7		
8		
9		
10		
11		
12		
13		
14		
15		
16		
17		
18		
19		
20		
21		
22		
23		
24		
25		
26		
27		
28		
29		
30		
31		

Amdt	Incorporated by	Date
32		
33		
34		
35		
36		
37		
38		
39		
40		
41		
42		
43		
44		
45		
46		
47		
48		
49		
50		
51		
52		
53		
54		
55		
56		
57		
58		
59		
60		
61		
62		

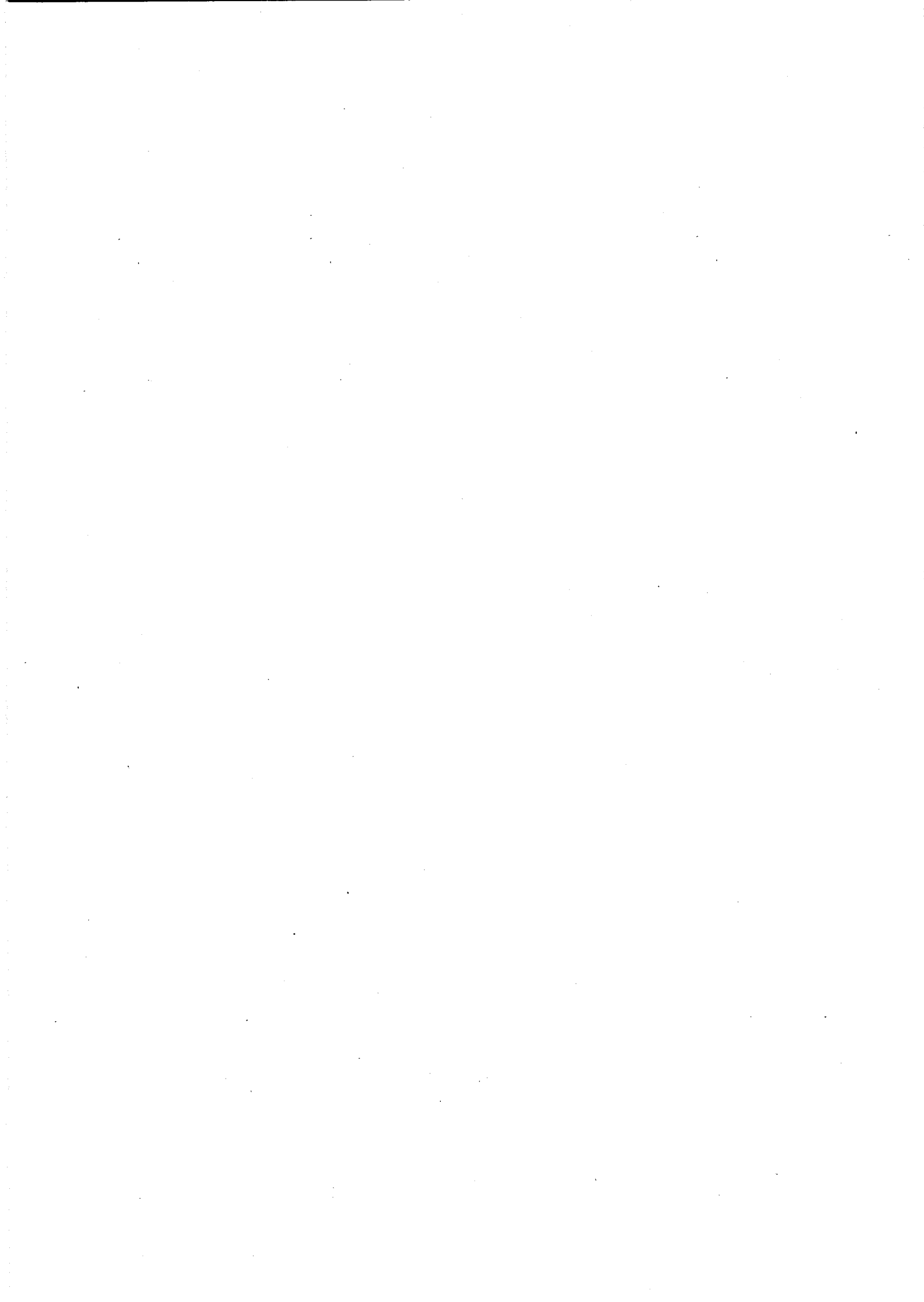

PREFACE

1 The controlling publication authority for this sub-category is:

Vehicles and weapons Branch REME
Chobham Lane
Chertsey Surrey KT16 OEE

2 All general instructions as issued are to be recorded on the general instruction index provided. Amendments to individual general instructions are to be recorded on the Instruction Amendment Record. All extant instructions and amendments can be found listed in the main AESP Index.

3 The controlling publication authority is responsible for the preparation and maintenance of the general instruction index and will issue completed and subsequent blank index pages as necessary. Instruction numbers can only be allocated by the controlling authority.

4 Comments on instructions are to be forwarded in accordance with AESP 0100-P-011-013.

GENERAL INSTRUCTION INDEX

This index is to be kept up to date by the user entering general instructions as and when they are published.

Instr No	STI/SI No	Subject	Approval No/Remarks
1		Fasteners: Turbo elbow to exhaust pipe	12-1954/1
2		Turbocharger: oil feed and drain fittings	12-1951
3		Engine sealing and sealed bolts	12-1938 and 12-1942
4		Brake governor (unloader) valve	
5		Viscous fan drive	50736/331JT
6		Transfer box: "Form in place" gaskets	12-1978
7		Cancelled	
8	AHC 067	Fuel sensing unit - leaking fuel	
9		Fuel gauge sender unit	50736/61
10		Transmission brake adjustment	12-2043
11		Turbocharger T35 (Airsearch)	12-2050
12		Transfer box control rods	0736/57

(continued)

GENERAL INSTRUCTION INDEX (continued)

Instr No	STI/SI No	Subject	Approval No/ Remarks
13		Front brake drums cracking	
14		Tachometer earthing	
15	AHC 074	Illuminated fog lamp switch: melting of bulb holder	
16		CANCELLED Front and rear braking lining material	C.R
17		Tachometer Drive Cable	
18		Fitting of fuel sender unit and associated harness	12-7007
19		Front panel left hand drive (L.H.D) and right hand drive (R.H.D)	12-7013
20		Instrument cluster + another completely revised	
21		Non-asbestos brakes	
22		Hydraulic Pump (CALM) variant	12-7047
23		Replacement of Air Cleaner Assy	GSV/04/036
24		Multi-pin plug connectors	GSV/04/052
25		Destruction of Category 533	
26			
27			
28			
29			
30			
31			
32			
33			
34			
35			
36			
37			

(continued)

GENERAL INSTRUCTION INDEX (continued)

Instr No	STI/SI No	subject	Approval No/ Remarks
38			
39			
40			
41			
42			
43			
44			
45			
46			
47			
48			
49			
50			
51			
52			
53			
54			
55			
56			
57			
58			
59			
60			
61			
62			



TRUCK, 4 TONNE, 4x4 BEDFORD MJ, (ALL VARIANTS)

GENERAL INSTRUCTION NO 1

Sponsor:
DGEME(A)

Publications Authority:
Vehicles and weapons Br REME
Project No: 71012(198)
File ref: VB/50736/47

AMENDMENT RECORD

Amdt	Incorporated by	Date	Amdt	Incorporated by	Date
1			3		
2			4		
3			6		

SUBJECT: Fasteners: Turbo Elbow to exhaust pipe.

(MAE 12-1954/1)

INTRODUCTION

1 The existing spring washers and plain nuts which fasten the exhaust downpipe to the turbocharger elbow are deleted. As and when it is necessary to disturb the subject joint, fit latest production pattern fasteners (listed in para 4 below). Vehicles produced after engine and chassis numbers shown in para 2 will incorporate these later pattern stores.

APPLICABILITY

- 2 Truck 4 Tonne 4 x 4 w/turbo Bedford MJ (all variants) up to:
- 2.1 Engine number 6543294
 - 2.2 Chassis number FT 101936

IMPLEMENTATION

3 Army units authorised to carry out levels 2, 3 and 4 maintenance, and RAF units.

Stores, tools and equipment

4

4.1 stores to be demanded

<u>Item No</u>	<u>COSA Section</u>	<u>NSN/Part No</u>	<u>Designation</u>	<u>Qty per eqpt</u>
1	G1	5310-12-125-0077	washer flat steel M10.5mm	4
2	G1	5310-99-139-2381	Nut self locking M10	4

4.2 Stores to be removed and discarded

3	G1	5310-99-135-9303	washer, lock, steel M10	4
4	G1	5310-99-122-5297	Nut, plain hexagon, ISO metric coarse, M10	4

Procedure

5 Carry out the instruction as follows:

Note...

The item numbers shown in para 4 are used as references throughout this instruction.

5.1 When it is necessary to remove or tighten the fasteners (items 3 and 4) fitted to the subject joint, these are to be replaced by the latest production pattern fastenings (items 1 and 2).

TRUCK CARGO 4 TONNE 4x4 BEDFORD MJ (ALL VARIANTS)

GENERAL INSTRUCTION NO 2

Sponsor:
DGEME(A)

Publications Authority:
Vehs & Wpns Br REME
Project No: 71012(206)
File ref: VB/50736/42

AMENDMENT RECORD

Amdt	Incorporated by	Date	Amdt	Incorporated by	Date
1			4		
2			5		
3			6		

SUBJECT: Turbocharger; oil feed and drain fittings
(MAE 12-1951)

INTRODUCTION

1 The manufacturer has introduced an improved pattern turbocharger oil drain pipe with a 12mm thick flange designed to obviate distortion of this flange. This item will only be issued by Ord when stocks of the existing drain pipe with an 8mm thick flange have been exhausted.

2 In all cases where the later pattern oil drain pipe is fitted, the opportunity is also to be taken to install longer bolts securing the oil feed adaptor housing to the turbocharger.

APPLICABILITY

3 Truck cargo 4 tonne 4x4 w/turbo Bedford MJ (all variants) held by user units, subject to the provisions of para 1.

REASON FOR INSTRUCTION

4 Code 5 - to conform to changes in pattern of commercial stores.

IMPLEMENTATION

5 Army units authorised to carry out levels 2,3 and 4 maintenance, and RAF units.

Stores Tools and Equipment

6

6.1 Ordnance will provide item 1 automatically when stocks of item 4 have been exhausted. When in receipt of this later pattern pipe assy (item 1), and where this instruction has not previously been incorporated into the vehicle in question, it is necessary to demand items 2 and 3 separately.

6.2 Later pattern stores

<u>Item No</u>	<u>COSA Section</u>	<u>NSN/Part No</u>	<u>Designation</u>	<u>Qty per eqpt</u>
1	7BD	2990-99-839-5308	Pipe assy-oil drain upper turbocharger	1
2	G1	5305-99-122-5367	Screw hex hd -M8 x 25mm lg	2
3	7BD	5306-99-736-6841	Bolt hex hd - M8 x 58mm lg	2

6.3 Early pattern stores

4	7BD	2990-99-763-5346	Pipe assy - oil drain upper turbocharger	1
5	Vauxhall	11042892	Screw hex hd - M8 x 22mm lg	2
6	Vauxhall	11051583	Bolt hex hd - M8 x 55mm lg	2

6.4 stores or suitable equivalent to be obtained locally

7	7BD	5330-99-763-5347	Gasket (oil drain pipe flange to turbocharger)	1
---	-----	------------------	--	---

Procedure

7 Carry out this instruction as follows:

Note...

The item numbers shown in para 6 are used as references throughout this instruction.

7.1 When issued with oil drain pipe assy c/w 12mm thick flange (item 1), remove and discard early pattern drain pipe assy c/w 8mm thick flange (item 4) and its 22mm lg securing screws (item 5). Retain any washers.

7.2 Remove old gasket and clean mating face and surrounding areas of turbocharger.

7.3 Connect oil drain pipe (item 1) and fit c/w gasket (item 7); secure using 25mm lg screws (item 2) plus washers retained during operation 7.1.

7.4 Remove 55mm lg bolts (item 6) retaining the oil feed adaptor housing to the turbocharger and install and tighten 58mm lg bolts (item 3) to between 12 and 16 Nm.

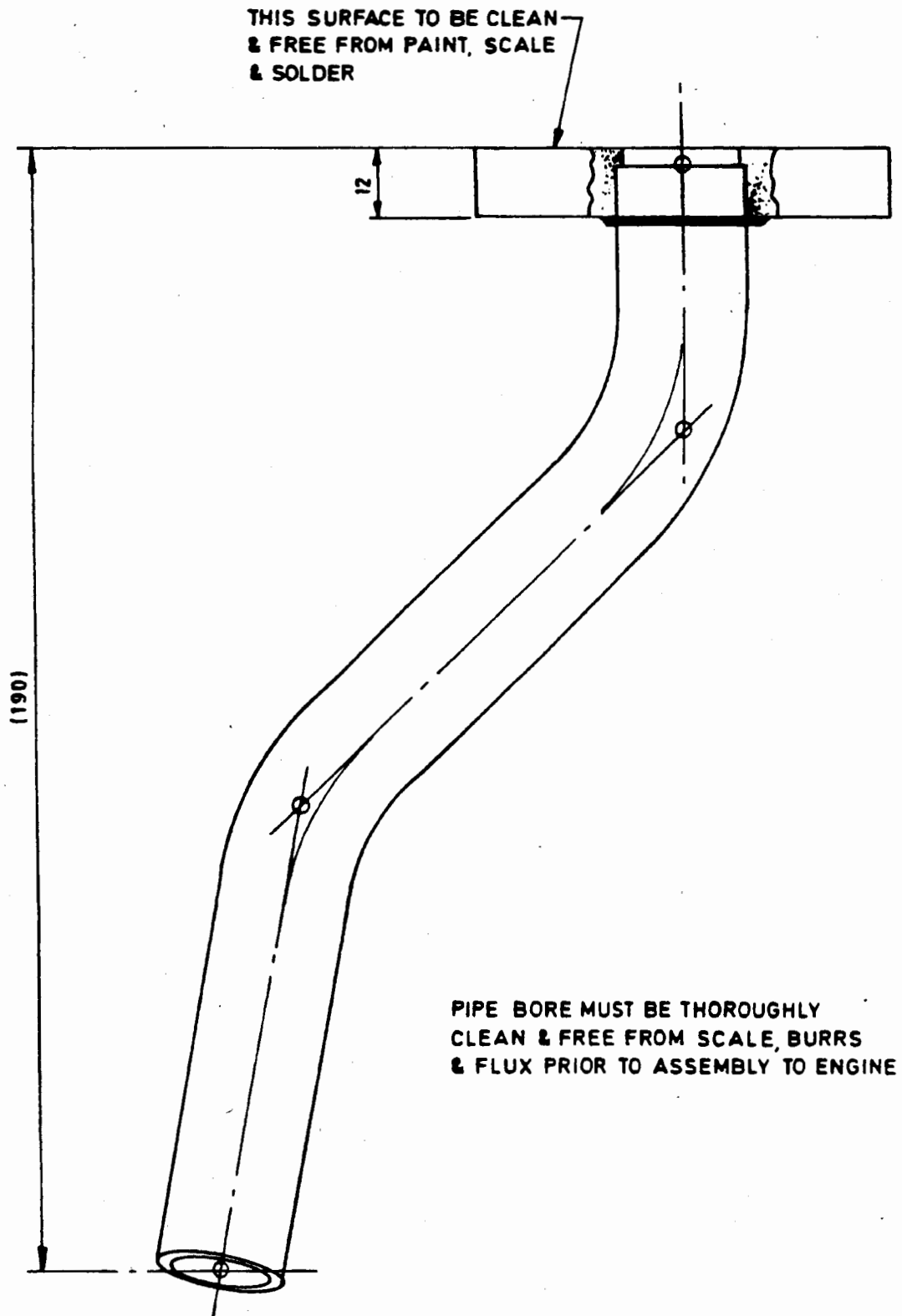

V7059/1

Fig 1. Modified oil drain pipe, upper turbocharger

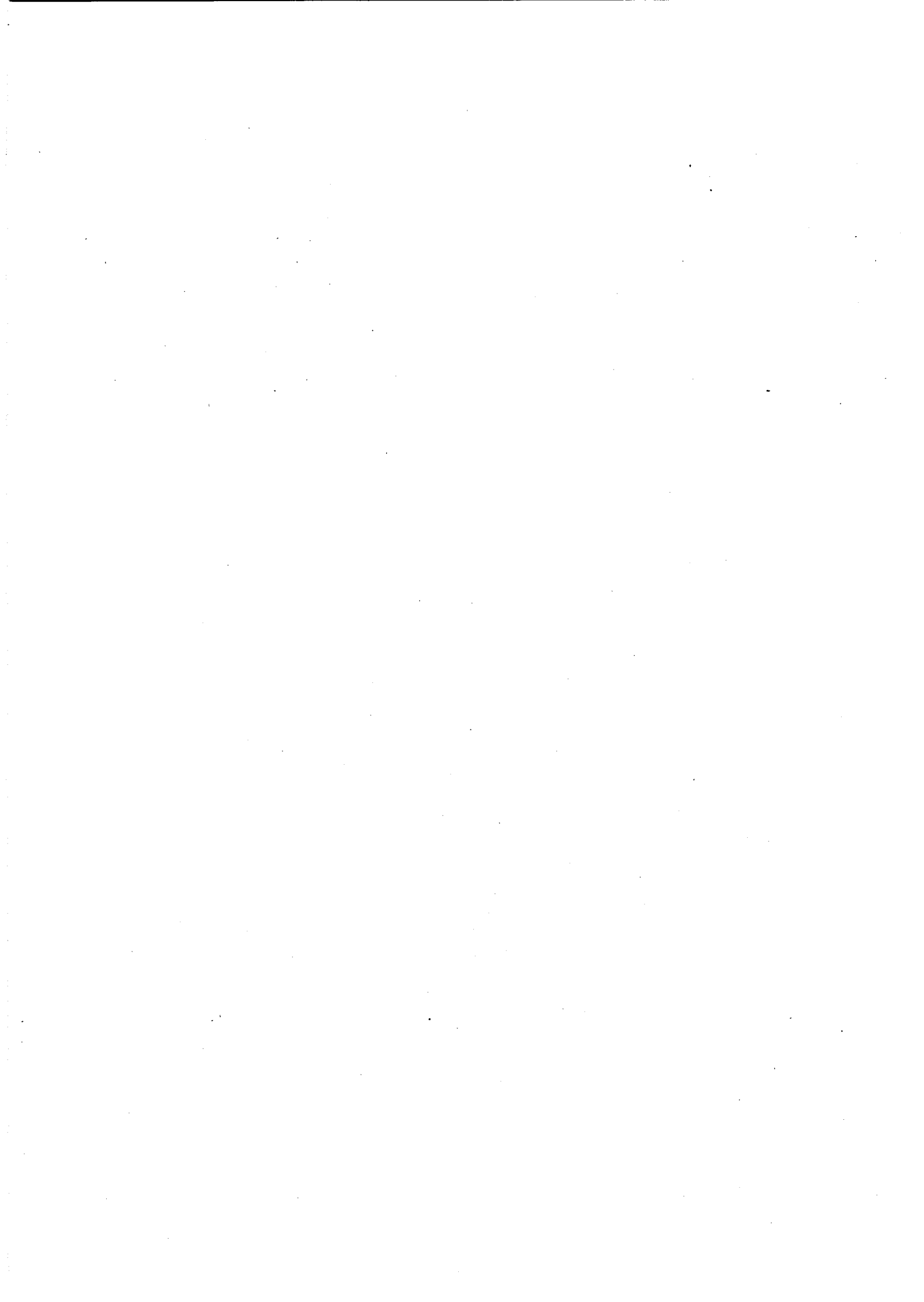

TRUCK, 4 TONNE, 4x4 BEDFORD MJ (ALL VARIANTS)

GENERAL INSTRUCTION NO 3

Sponsor:
DGEME(A)

Publications Authority:
Vehs & wps Br RÈME
Project No: 71012(224)
File ref: 50736/38
50736/40

AMENDMENT RECORD

Amdt	Incorporated by	Date	Amdt	Incorporated by	Date
1			4		
2			5		
3			6		

SUBJECT: Engine sealing and sealed bolts
(12-1938 and 12-1942)

INTRODUCTION

1 On production the manufacturers have introduced sealed bolts and sealer added to appropriate joints to obviate engine oil leaks. This instruction informs workshops of the necessary detail for overhauling engines, and user units when changing components or servicing engine.

APPLICABILITY

2 Truck cargo 4 tonne 4x4 Bedford MJ (all variants).

IMPLEMENTATION

3 Items affected

3.1 Old

<u>Item No</u>	<u>COSA Section</u>	<u>NSN/Part No</u>	<u>Designation</u>	<u>Oty per eqpt</u>
1		0120229	Bolt - induction manifold to cyl head	3
2		173063	Bolt - induction manifold to cyl head	1
3		178429	Bolt - induction manifold to cyl head	1

<u>Item No</u>	<u>COSA Section</u>	<u>NSN/Part No</u>	<u>Designation</u>	<u>Qty per eqpt</u>
4		142601	Bolt - induction manifold to cyl head	2
5		122007	Bolt - compressor to timing gear case	5
6		11055462	washer lock - compressor to timing gear case	5
7		121887	Bolt - push rod cover to crankcase	4
8		120380	washer lock - push rod cover to crankcase	4
9		9907485 or 120854	Bolt - push rod cover to crankcase	25
10		120380	washer lock - push rod cover to crankcase	25
11		122089	Bolt - fuel return pipe clip to manifold and cyl head	1
12		9431187	Bolt - thermo tank bracket to manifold and cyl head	2
<u>3.2 New</u>				
13	7BD	5306-99-785-0311	Bolt -induction manifold to cyl head (Pt No 9908335)	3
14	7BD	5306-99-785-0312	Bolt - induction manifold to cyl head (Pt No 9908337)	1
15	7BD	5306-99-785-0313	Bolt - induction manifold to cyl head (Pt No 9908338)	1
16	7BD	5306-99-785-1014	Bolt - induction manifold to cyl head (Pt No 9908340)	2
17	7BD	5306-99-785-1015	Bolt - compressor to timing gear case (Pt No 9908133)	5
18	7BD	5306-99-785-1016	Bolt - push rod cover to crankcase (Pt No 9908333)	4
19	7BD	5306-99-785-1017	Bolt - push rod cover to crankcase (Pt No 9908332)	25
20	7BD	5306-99-785-1018	Bolt - fuel return pipe clip to manifold and cyl head (Pt No 9908093)	1

<u>Item No</u>	<u>COSA Section</u>	<u>NSN/Part No</u>	<u>Designation</u>	<u>Qty per eqpt</u>
21	7BD	5306-99-785-1019	Bolt - thermo tank bracket to manifold and cyl head (Pt No 9908339)	2
22	H1	8030-99-225-0799	Sealer, Golden Hermetite	A/R
23	H1	8030-99-225-0249	Sealer, Loctite with teflon	A/R
24	H1	8030-99-224-0759	wellseal	A/R

4 Detail

4.1 When overhauling or repairing engine it is not necessary to replace the new type bolts (items 13 and 21 inclusive) or existing bolts and washers (items 1 to 12 inclusive), but the bolts will need cleaning and loctiting on reassembly using item 23.

4.2 Sealer, Golden Hermetite (item 22) is to be used on the following:

- 4.2.1 Cylinder block, front and rear bearing caps to sump joint face.
- 4.2.2 Front and rear main bearing caps to block.
- 4.2.3 Timing gear case assembly.
- 4.2.4 Timing gear case cover plate.
- 4.2.5 Push rod cover gasket to cylinder block and head.
- 4.2.6 Push rod cover gasket.
- 4.2.7 Power steering pump (if fitted).

4.3 Sealer, Loctite with teflon (item 23) is to be used on the following:

- 4.3.1 Oil duct cup plug.
- 4.3.2 Bolt, cover plate or power steering pump to timing case.

4.4 wellseal (item 24) is to be used on the exhaust manifold sealing rings.

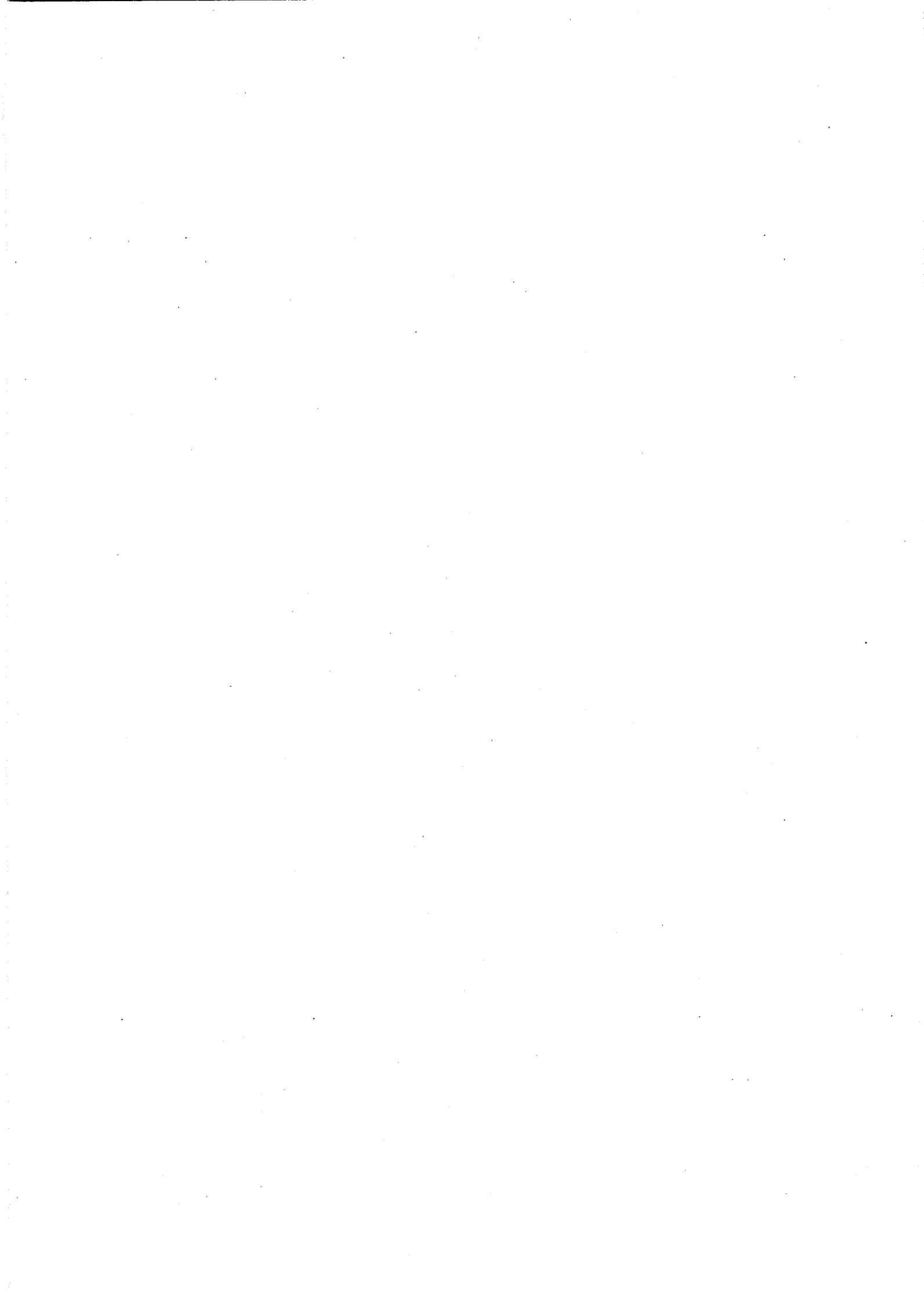

TRUCK, 4 TONNE 4x4 BEDFORD MJ (ALL VARIANTS)

GENERAL INSTRUCTION NO 4

Sponsor:
DGEME(A)

Publications Authority:
Vehs & wps Br REME
Project No: 71112(4)
File ref: 50736/54

AMENDMENT RECORD

Amdt	Incorporated by	Date	Amdt	Incorporated by	Date
1			4		
2			5		
3			6		

SUBJECT: Brake governor (unloader) valve

INTRODUCTION

1 The governor valve, at present, requires the removal of the mounting nuts and loosening of the air pipes to remove the valve sufficiently to gain easy access to the adjusting screw with a screwdriver. This instruction informs user units that they may, at their discretion introduce a new hexagon headed screw to the governor valve, which will enable the valve to be adjusted in situ using a 7/16 in. AF open jaw spanner.

APPLICABILITY

2 Truck cargo 4 tonne 4 x 4 Bedford MJ (all variants).

IMPLEMENTATION

3 Replace existing slotted headed screw (LV6MT9 5305-99-833-7770) with a suitable 1/4 in. UNC hexagon headed screw, ensuring that the screw is the same length and the threaded end has the same profile as the original screw.

4 Adjust the governor valve as necessary.

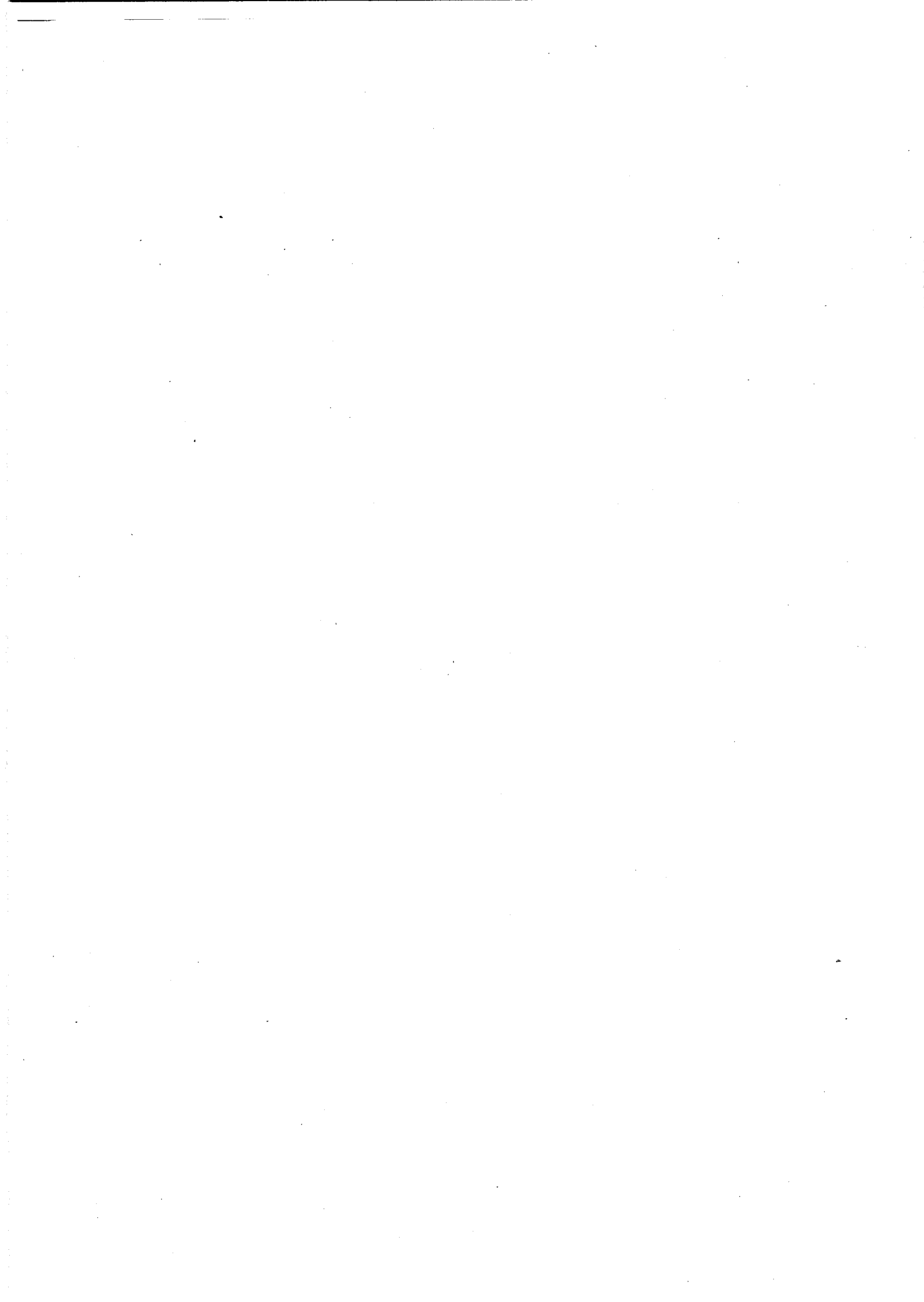

TRUCK 4 TONNE, 4x4 BEDFORD MJ (ALL VARIANTS)

GENERAL INSTRUCTION NO 5

Sponsor:
DGEME(A)

Publications Authority:
Vehs & Wpns Br REME
Project No: 71112(11)
File ref: 50736/33

AMENDMENT RECORD

Amdt	Incorporated by	Date	Amdt	Incorporated by	Date
1			4		
2			5		
3			6		

SUBJECT: Viscous fan drive
(50736/33/JT)

INTRODUCTION

1 To avoid having to replace the water pump when a new type viscous fan is fitted, or having to replace old type viscous fan when a new type water pump is fitted, it is permissible to drill and tap the holes required in the water pump pulley. This instruction gives the necessary detail.

APPLICABILITY

2 Truck 4 tonne 4 x 4 Bedford MJ (all variants).

IMPLEMENTATION

3 Detail

3.1 The pulley on the water pump is to be drilled and tapped to 5/16in. 18 UNC using viscous fan as a template.

3.2 The pulley must not be removed to re-drill and must be supported when drilling to ensure drilling loads are self contained and not passed through the water pump bearings.

3.3 Care must be taken to ensure that swarf particles from the drilling or tapping operation do not enter the water pump bearings.

3.4 The relative position of the new set of holes to the old is unimportant.

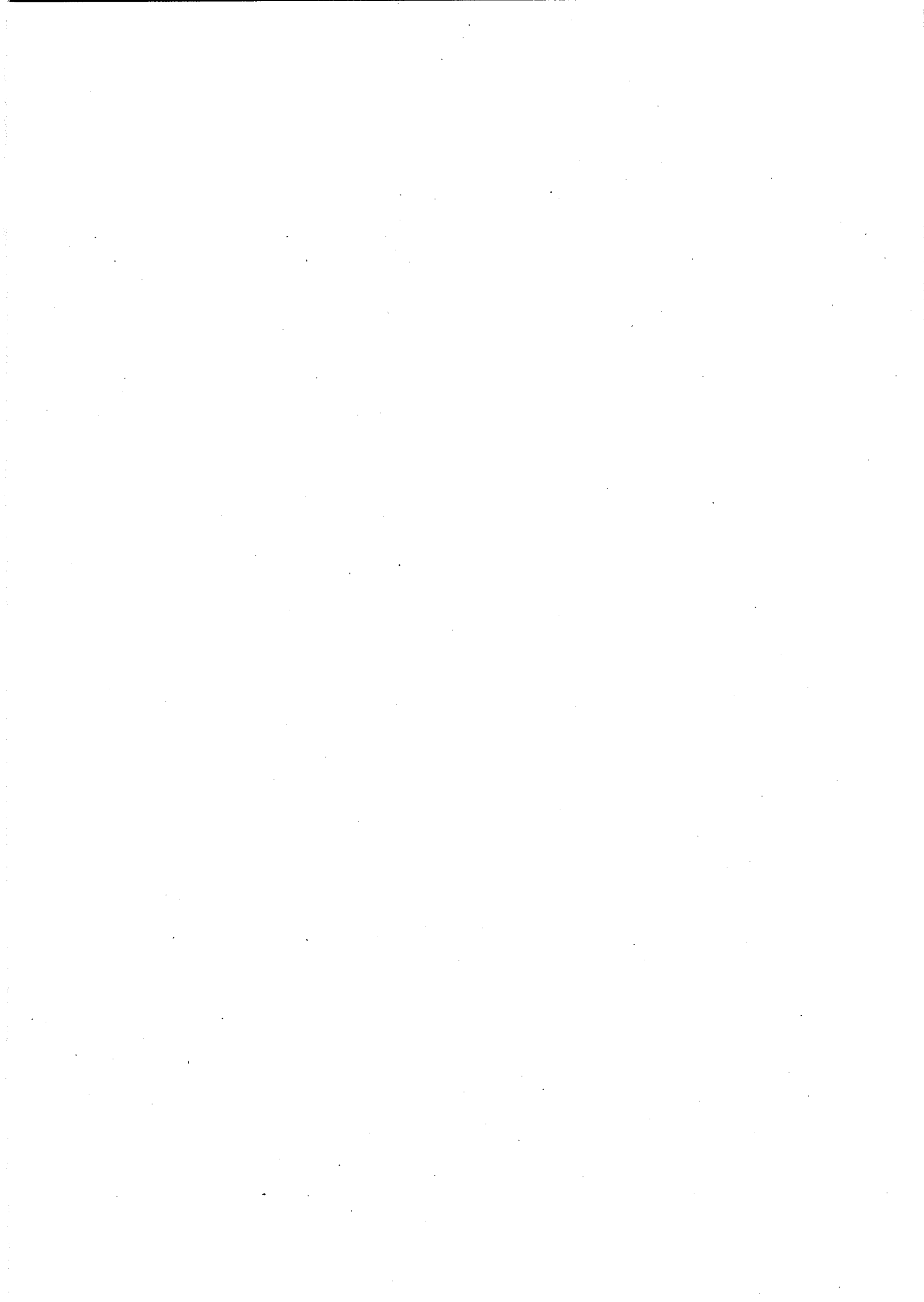

TRUCK, 4 TONNE, 4x4 BEDFORD MJ (ALL VARIANTS)

GENERAL INSTRUCTION NO 6

Sponsor:
DGEME(A)

Publications Authority:
Vehs & wps Br REME
Project No: 71112(66)
File ref: 50736/52

AMENDMENT RECORD

Amdt	Incorporated by	Date	Amdt	Incorporated by	Date
1			7		
2			8		
3			9		

SUBJECT: Transfer box: 'form-in-place' gaskets
(12-1978)

INTRODUCTION

1 This instruction informs workshops that on current production vehicles the shaft end cover gaskets have been replaced with 'form-in-place' gaskets, and the shaft end covers have been revised to make up for the lost gasket thickness. When existing stocks of the shaft end covers are exhausted they will be replaced by the new shaft end covers. The old covers will still require the gaskets, whilst the new covers will require Loctite 510 superfast flange sealant to make the 'form-in-place' gaskets.

APPLICABILITY

2 Truck cargo 4 tonne 4 x 4 Bedford MJ (all variants)

IMPLEMENTATION

3 Items affected

3.1 Old

<u>Item No</u>	<u>COSA Section</u>	<u>NSN/Part No</u>	<u>Designation</u>	<u>Oty per veh</u>
1	7BD	2520-99-833-7778	Input pinion shaft cover assy (Pt No 91048404)	1
2	7BD	5330-99-832-9292	Gasket, input pinion shaft cover and layshaft front cover (Pt No 91056138)	2
3	7BD	2520-99-814-0085	Layshaft front cover assy (Pt No 8821382)	1

<u>Item No</u>	<u>COSA Section</u>	<u>NSN/Part No</u>	<u>Designation</u>	<u>Qty per veh</u>
4			Rear cover assy (Pt No 2718157)	1
5	7BD	5330-99-874-0937	Gasket, rear cover assy (Pt No 7154614)	1
6			PTO front cover assy (Pt No 8821392)	1
7	7BD	2520-99-874-0860	Gasket, PTO front cover assy (Pt No 6381563)	1
<u>3.2 New</u>				
8	7BD	2520-99-839-5397	Housing mechanical drive, input shaft cover assy (Pt No 91116695)	1
9	7BD	2520-99-839-5398	Housing mechanical drive, layshaft front cover assy (Pt No 91116697)	1
10	7BD	2520-99-839-5399	Housing mechanical drive, transfer box rear cover assy (Pt No 91116702)	1
11	7BD	2520-99-839-5400	Housing mechanical drive, PTO front cover assy (Pt No 91116700)	1
12	H1	8030-99-748-9983	Sealing compound, Loctite 510	As req

Note...

Items 6, 7 and 11 apply to winch variants only.

TRUCK, 4 TONNE, 4x4 BEDFORD MJ (ALL VARIANTS)

GENERAL INSTRUCTION NO 7

CANCELLATION

INTRODUCTION

1 This instruction authorises the cancellation of SI/MT BEDFORD AGC 026. Front brake drums cracking which has been superseded by Gen Instr No 13.

ACTION

- 2 Remove and destroy Gen Instr No 7, Sept 87, Page 1/2.
- 3 File this instruction in its place for reference.



TRUCK, 4 TONNE, 4x4 BEDFORD MJ (ALL VARIANTS)

GENERAL INSTRUCTION NO 8

File ref: 0736/60

Vehicles & weapons Branch REME
Project No: 71212 (211)

- A STI MT/Bedford AHC 067
Fuel sensing unit - leaking fuel
- B 1 Truck, 4 tonne, 4 x 4 Bedford MJ (all variants) with fuel sensing unit fitted in rear wall of the fuel tank under the longitudinal chassis member.
- 2 Truck, 4 tonne, 4 x 4 Bedford MJ (all variants) with fuel sensing unit fitted in rear wall of the fuel tank under the longitudinal chassis member.
- C Cases have been reported of the fuel sensing unit loosening and falling from the fuel tank resulting in fuel spillage.
- D 1a At the earliest opportunity but not later than 14 days following receipt of this instruction.
- 1b (1) Examine fuel tank for any sign of leakage from the fuel sensor joint.
- (2) If no sign of leakage is found drill two holes in the walls of the tank and sensor mounting plate under the locking lugs at maximum metal condition.
- (3) Using locking wire in drilled holes secure sensor mounting plate to fuel tank.
- (4) If leakage is found, telephone Mr J Traylor on Chertsey Mil Ext 2214 for further advice.
- 1c 1 man hour Veh Mech (Army) MT Mech/Tech (RAF)
- 2a Before issue of vehicles from CVDs.
- 2b NA
- E 1 RAF UNITS - Enter details on instruction index. Record STI number on form AFG1084A and F4870. In addition report to FORWARD (RAF) using code:
- AHC067
- 2 ARMY UNITS - Enter details on instruction index. Record Gen Instr No and action taken in vehicle documents.
- F Defect reports are not required.
- G 1 Compliance with signal STI MT/Ford AHC067 Fuel sensing unit, satisfies this instruction.
- 2 NA
- H NA

TRUCK 4 TONNE, 4x4, BEDFORD MJ

(ALL VARIANTS)

GENERAL INSTRUCTION NO 9

Sponsor:
DGEME(A)

Publications Authority:
Vehs & Wpns Br REME
Project No: 71212 (304)
File ref: 50736/61

AMENDMENT RECORD

Amdt	Incorporated by	Date	Amdt	Incorporated by	Date
1			4		
2			5		
3			6		

SUBJECT: Fuel gauge sender unit
(50736/61)

INTRODUCTION

1 Later vehicles are equipped with a revised tank unit having a bayonet type mounting. This instruction details the method of special tool manufacture and the fitting method.

1.1 Limitations on use of equipment. NIL

APPLICABILITY

2 Truck 4 tonne, 4x4, Bedford MJ (All Variants) held by user units.

IMPLEMENTATION

3 Detail

3.1 Units are to obtain Drawing No REME 002272 as detailed in EMER Man Y030 Chap 6 Fig 36 and manufacture the tool as per the drawing.

3.2 The tool is to be used to tighten the fuel gauge sender unit after repair of any damage, to 19Nm (14 lbf ft).

3.3 The sender is to be lockwired after it is established that no leaks are present.

Note ...

If sender units are already lockwired and no leaks are present then units are to take no action.



TRUCK CARGO 4 TONNE 4x4

BEDFORD MJ (ALL VARIANTS)

GENERAL INSTRUCTION NO 10

Sponsor:
DGEME (A)

Publications Authority:
Vehicles & Weapons Branch REME
Project No: 71312(3)
File ref: 0736/65

AMENDMENT RECORD

Amdt	Incorporated by	Date	Amdt	Incorporated by	Date
1			4		
2			5		
3			6		

SUBJECT: Transmission Brake Adjustment
(MAE 12-2043)

INTRODUCTION

1 As a result of in-service complaints the transmission brake adjustment has been revised, this instruction gives the necessary detail.

APPLICABILITY

2 Truck cargo 4 tonne 4x4 Bedford MJ (all variants).

IMPLEMENTATION

3 Detail

3.1 Pull handbrake lever on hard to centralise shoes, then release.

3.2 Adjust transmission brake until drum cannot be rotated, then back off until drum is free to rotate.

3.3 Repeat 3.1 and 3.2 until the brake adjuster cannot be turned on without causing the linings to rub against the drum.

3.4 Slacken the locknut on the cable adjustment clevis, adjust clevis until all slack cable is taken up. Tighten locknut and ensure the brake drum is not rubbing.

3.5 Apply a load of 50lbf at end of handbrake lever. The lever must not move more than 11 notches on handbrake lever ratchet.

3.6 If after the above procedure the handbrake is considered inefficient, forward defect reports quoting brake adjusted in accordance with this instruction.

TRUCK CARGO, 4x4, BEDFORD MJ (ALL VARIANTS)

GENERAL INSTRUCTION NO 11

(Completely revised)

Amdt Instrs

Remove Pages 1-2 dated May 88. Insert Pages 1-2 dated Jan 90.

Sponsor:
DGEME(A)

Publications Authority
Vehs & Wpns Br REME
Project No: 71411(280)
File ref: 0736/67

AMENDMENT RECORD

Amdt	Incorporated by	Date	Amdt	Incorporated by	Date
1			4		
2			5		
3			6		

SUBJECT: Turbocharger T35 (Airsearch)
(MAE 12-2050)

INTRODUCTION

1 This instruction is to inform workshops that vehicles may be fitted in production with either a Holset H1B or an Airsearch T35 turbocharger, and what action may be taken when either needs to be replaced.

APPLICABILITY

2 Truck cargo 4 tonne 4x4 Bedford MJ (all variants).

REASON

3 Code 6 - release of alternative supplier.

IMPLEMENTATION

4 Items affected.

4.1 Old

<u>Item No</u>	<u>COSA Section</u>	<u>NSN/Part No</u>	<u>Designation</u>	<u>Qty per veh</u>
1	7BD	2990-99-763-6032	Turbocharger (Holset H1B)	1

4.2 New

2	6MT12	2990-99-793-2021	Turbocharger (Airsearch T35)	1
3	7BD	2990-99-742-7885	Adaptor - oilfeed	1
4	7BD	5330-99-832-7214	Gasket	1
5	7BD	2940-99-763-6037	Adaptor - oil feed	1
6	7BD	5330-99-763-5347	Gasket	1

Procedure

Note ...

The item numbers shown in para 4 are used as references throughout this instruction.

5 where possible like should be replaced with like, if for any reason this is not possible then to fit a Holset H1B turbocharger (item 1) in the place of an Airsearch T35 (item 2) adaptor (item 5) and gasket (item 6) need to be demanded and used to enable embodiment. To fit an Airsearch T35 turbocharger (item 2) in the place of a Holdset H1B (item 1) then adaptor (item 3) and gasket (item 4) need to be demanded and used to enable embodiment.

TRUCK 4 TONNE, 4x4, BEDFORD MJ (ALL VARIANTS)

GENERAL INSTRUCTION NO 12

Sponsor:
DGEME(A)

Publications Authority:
Vehicles and Weapons Branch REME
Project No: 71312 (89)
File ref: 0736/57

AMENDMENT RECORD

Amdt	Incorporated by	Date	Amdt	Incorporated by	Date
1			4		
2			5		
3			6		

SUBJECT: Transfer box control rods
(0736/57)

INTRODUCTION

1 This instructions informs workshops that on current production vehicles the transfer box control rods have been shortened to overcome setting up problems. workshops who experience difficulty in gear change or stiffness in operation are advised to shorten transfer box control rods in accordance with this instruction.

APPLICABILITY

2 Truck 4 tonne, 4x4 Bedford MJ (all variants).

IMPLEMENTATION

3 Detail

- 3.1 Remove the existing transfer box control rods.
- 3.2 Decrease lengths of transfer box control rods by 1/2 in.
- 3.3 Drill transfer box control rods to increase its depth by 3/4 in. and retap to existing thread 3/8 in. 24 UNF.
- 3.4 Refit transfer box control rods and adjust to give smooth operation.

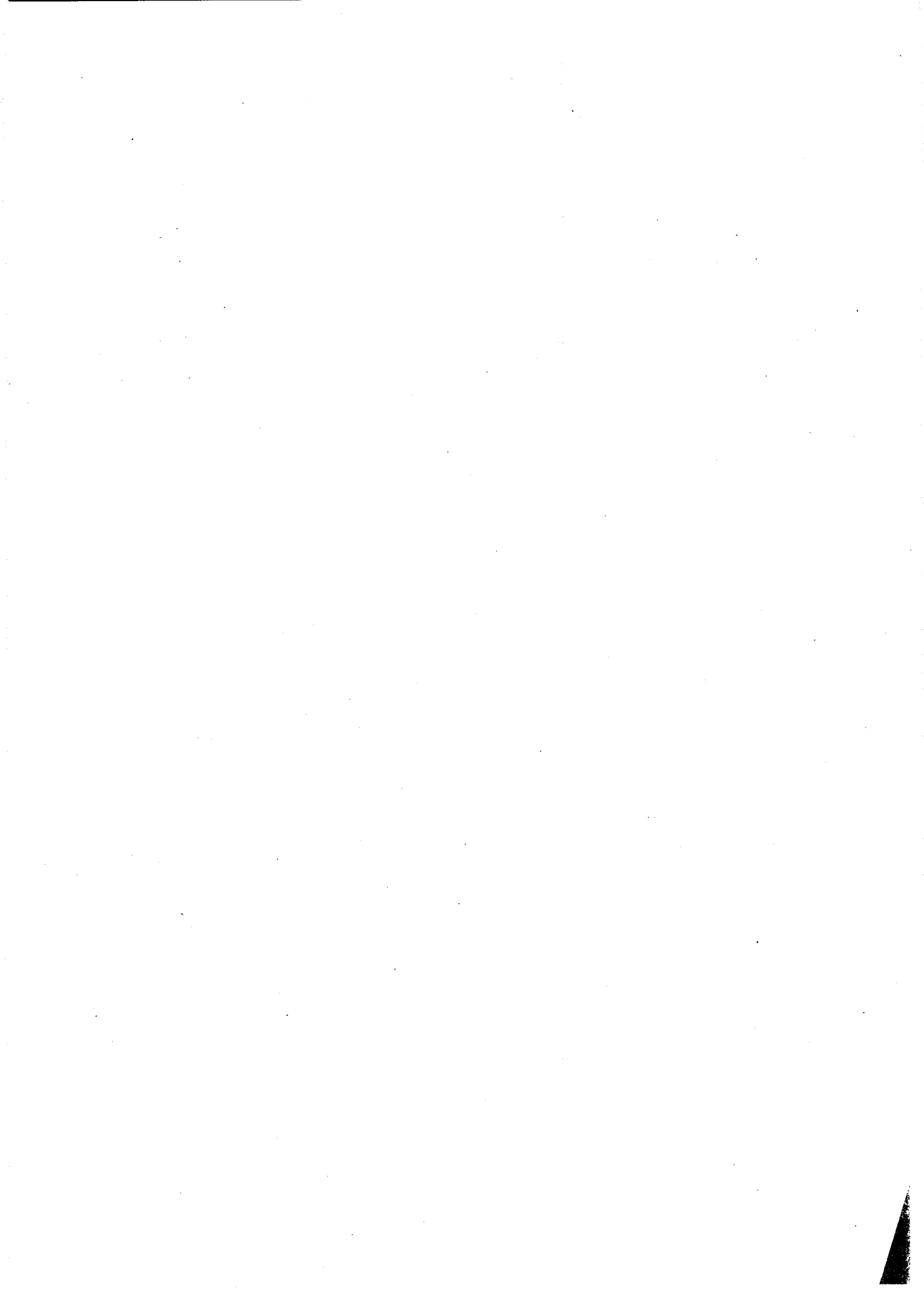

TRUCK, 4 TONNE, 4x4, BEDFORD MJ (ALL VARIANTS)

GENERAL INSTRUCTION NO 13

Sponsor:
DGEME(A)

Publications Authority:
Vehs & wps Br REME
Project No: 71312 (155)
File ref: 0736/58

AMENDMENT RECORD

Amdt	Incorporated by	Date	Amdt	Incorporated by	Date
1			4		
2			5		
3			6		

SUBJECT: Front brake drums cracking

INTRODUCTION

1 Cases have been reported of front brake drums cracking around the circumference and through the jack off holes caused by a tight fit on the hub. Design changes are being implemented on production. For in service vehicles the following procedure should be adopted when the brake drum requires removal.

APPLICABILITY

2 Truck, 4 Tonne, 4x4, Bedford MJ (all variants) held by user units.

IMPLEMENTATION

3

3.1 Remove the brake drums, DO NOT USE THE JACK OFF HOLES IF THE DRUM PROVES DIFFICULT TO REMOVE. Refer to AESP 2320-H-100-522, Chapter 6, Pages 3 and 4, Para 17-21, for hub and drum assembly removal and separate by allowing the assembly to impact on the drum rim.

3.2 Thoroughly clean the drum I.D. where it registers on the hub.

3.3 Thoroughly clean the hub in the area referred to in 3.2.

3.4 Refit the hub (if removed in para 3.1).

3.5 Check the fit of the brake drum on the hub, it should slide fully home with the minimum of effort. If this is not the case remove sufficient material from the drum I.D. to facilitate an easy fit.

3.6 Smear anti-seize compound on the hub register and refit the drum.

Note ...

Anti-seize compound - "Copper slip"

2 oz tube (H1-8030-99-220-2083)

1 lb tin (H1-8030-99-224-6794)

or

Anti-seize compound - "Copper Crest"

225 gram tube 34B 1835

Ref: AP 1086, fiche 47, Page 7, sub section 34B, item 16.

TRUCK, 4 TONNE, 4x4

BEDFORD MJ, (ALL VARIANTS)

GENERAL INSTRUCTION NO 14

Sponsor:
DGEME(A)

Publications Authority:
Vehicles and weapons Branch REME
Project No: 71312 (172)
File ref: 0736/68

AMENDMENT RECORD

Amdt	Incorporated by	Date	Amdt	Incorporated by	Date
1			4		
2			5		
3			6		

SUBJECT: Tachometer Earthing

INTRODUCTION

1 It has been found necessary to fit earthing leads to the tachometer and mounting bracket to prevent radio interference. This instruction gives the necessary detail.

APPLICABILITY

2 Truck, 4 tonne, 4x4, Bedford MJ, FFR vehicles (VAC 2096-8100).
ERN 82 KD 07 to 82 KD 40 inclusive, held by user units.

IMPLEMENTATION

3 Refer to Fig 1.

3.1 Remove the bolt at position A, clean the area and the bolt, fit one earthing lead and refit the bolt.

3.2 Remove the tachometer mounting nut at position B, clean the area and fit a second earthing lead, refit the nut.

3.3 Remove the bolt on cab bracket at position C, clean the area and bolt, secure both earthing leads and refit the bolt.

3.4 Secure the earthing leads safely using tie wraps.

Earthing leads (MPN 91132738) and tie wraps can be obtained from:

H B D&M, 6 MAG
Vehicles & weapons Br REME
Chobham Lane
Chertsey
Surrey KT16 OEE

Tel: Chertsey Mil 2214

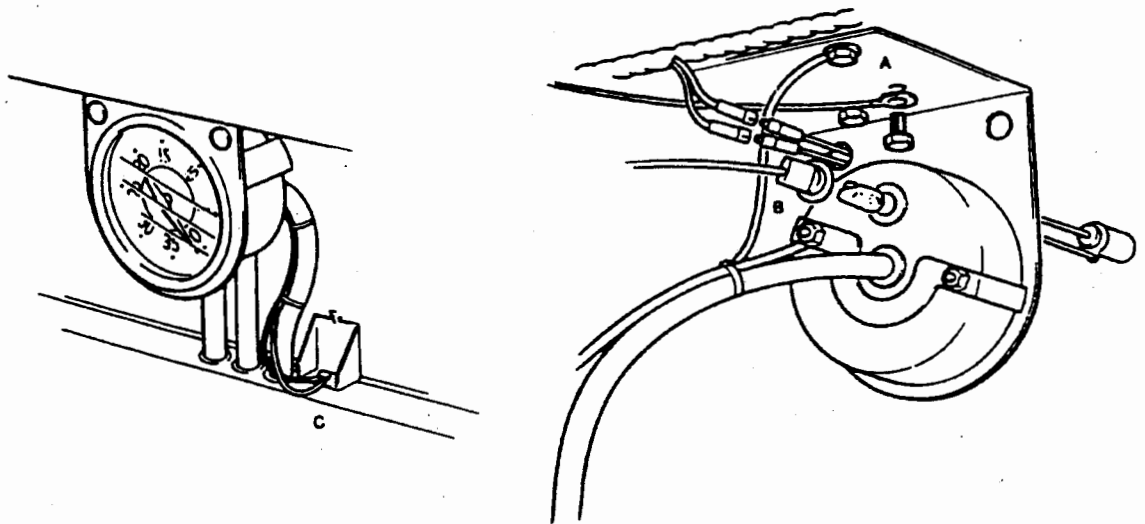

Fig 1 Tachometer Earthing

TRUCK, 4 TONNE, 4x4, BEDFORD MJ

GENERAL INSTRUCTION NO 15

File ref: 0736/76

Vehs & Wpns Br REME
Project No: 71612 (98)

- A STI/Bedford AHC 074
Illuminated Fog lamp switch - melting of the bulb holder.
- B1 Truck, 4 Tonne, Bedford MJ (All variants) fitted with illuminated switch
7BD 5930-99-763-4527.
- 2 Truck, 4 tonne, Bedford MJ (All variants) fitted with illuminated switch
7BD 5930-99-763-4527.
- C Cases have been reported of melted bulb holders within the subject
illuminated switch.
- D1a At the earliest opportunity but no later than 28 days following receipt
of this Instruction.
- 1b (1) To overcome the problem a one watt bulb in place of the 3 watt will
be fitted to all new switches, these will be issued when present stock
is exhausted.
- (2) Units are to ensure that all new and in-service switches are fitted
with a one watt bulb NSN X5 6240-99-995-9811.
- (3) Some specialist applications may have more than one switch fitted,
in these cases the same procedure must be applied to all switches.
- 1c 0.5 man-hour - Veh Mech (Army)/MT Mech/MT Tech (RAF)
- 2a Before issue of vehicles from CVDs.
- 2b N/A
- E1 RAF UNITS

Enter detail on instruction index. Record STI/SI number on form AF
G1084A and F4870. In addition report to FORWARD (RAF) using code:

AHC074

Note ...

RAF Units operating STAMA are also to complete ADP MTMS job
Certification Sheet and to follow the procedures laid down in AP
100C-08A. : Unquote.

2 ARMY UNITS

Enter details on instruction index. Record Gen Instr No and action taken in vehicle documents.

F Defect reports are not required.

G1 N/A

2 N/A

H N/A

CONDITIONS OF RELEASE

- ~~1 This information is released by the UK Government for Defence purposes only.~~
- ~~2 This information must be afforded the same degree of security protection as that afforded to information of an equivalent security marking originated by the recipient Government or as required by the recipient Government's security regulations.~~
- ~~3 This information may be disclosed only within the Defence Department of the recipient Government, except as otherwise authorized by the Ministry of Defence (Army).~~
- 4 This information may be subject to privately owned rights.

TRUCK, 4 TONNE, 4 X 4 BEDFORD MJ (ALL VARIANTS)

GENERAL INSTRUCTION NO. 16

CANCELLATION

INTRODUCTION

- 1 This instruction authorises the cancellation of Gen Instr No. 16, front and rear brake lining material change. It has been superseded by Gen Instr No.21, the introduction of non-asbestos brake shoe materials.

ACTION

- 2 Remove and destroy Gen Instr No. 16, Jul 92, Pages 1 and 2.
- 5 File this instruction in its place for reference.

P00419 (173)
DLO Chertsey

0005/NTRP1008
May 00

