



# Notice of variation and consolidation with introductory note

## The Environmental Permitting (England & Wales) Regulations 2010

---

Seabank Power Limited.

Seabank Power Station  
Severn Road  
Hallen  
Bristol  
BS10 7SP

### **Variation application number**

EPR/BV3006IN/V003

### **Permit number**

EPR/BV3006IN

# Seabank Power Station

## Permit number EPR/BV3006IN

### Introductory note

#### **This introductory note does not form a part of the notice.**

Under the Environmental Permitting (England & Wales) Regulations 2010 (schedule 5, part 1, paragraph 19) a variation may comprise a consolidated permit reflecting the variations and a notice specifying the variations included in that consolidated permit.

Schedule 1 of the notice specifies that all the conditions of the permit have been varied and schedule 2 comprises a consolidated permit which reflects the variations being made and contains all conditions relevant to this permit.

The requirements of the Industrial Emissions Directive (IED) 2010/75/EU are given force in England through the Environmental Permitting (England and Wales) Regulations 2010 (the EPR) (as amended).

This Permit, for the operation of large combustion plant (LCP), as defined by articles 28 and 29 of the Industrial Emissions Directive (IED), is varied by the Environment Agency to implement the special provisions for LCP given in the IED, by the 1 January 2016 (Article 82(3)). The IED makes special provisions for LCP under Chapter III, introducing new Emission Limit Values (ELVs) applicable to LCP, referred to in Article 30(2) and set out in Annex V.

As well as implementing Chapter III of IED, the consolidated variation notice takes into account and brings together in a single document all previous variations that relate to the original permit issued. It also modernises all conditions to reflect the conditions contained in our current generic permit template.

The Operator has chosen to operate this LCP under the ELV compliance route. This is a change from the previous operating regime which was operation under emission limits determined by an assessment for the best available techniques (BAT).

The variation notice uses updated LCP numbers in accordance with the most recent DEFRA reference numbers. The LCP references have changed as follows:

- LCP 265 is changed to LCP 313;
- LCP 266 is changed to LCP 314;
- LCP 267 is changed to LCP 315 and
- The black start facility has been issued a new reference LCP 409

The net thermal input of the LCPs is as follows: LCP 313 consists of one 657.861 MWth CCGT, LCP 314 consists of one 657.861 MWth CCGT, LCP 315 consists of one 672.714 MWth CCGT and LCP 409 consists of one OCGT its thermal input will be notified under pre operational condition PO1

The rest of the installation is unchanged and continues to be operated as follows:

Seabank Power Station is a combined cycle gas turbine (CCGT) plant fired on natural gas which is supplied via a 26 km dedicated gas line from the National Grid Gas Network. There are two modules on site.

Module 1 has two gas turbines and two heat recovery steam generators with one steam turbine, this generates approximately 755 MW of electrical power.

Module 2 has one gas turbine, one heat recovery steam generator and one steam turbine, this generates approximately 385 MW of electrical power.

The combined thermal input of modules 1 and 2 is 1988MWth.

The permit authorises the operation of an open cycle turbine which has not been constructed at the time of issue of this variation; this plans to operate as a black start generator, the black start generator will be utilised during local grid failure to allow the station to start up without the use of any external power supplied from the grid. Once constructed and after completion of the pre operational measures PO1, PO2 and PO3 this facility may also operate commercially to supply power to the grid as required.

Cooling at the station is achieved in three hybrid cooling towers using treated effluent supplied from the Avonmouth sewage treatment plant. After use the purge from the cooling towers it is returned to the outfall of the sewage treatment works for discharge in to the Severn Estuary.

A water treatment plant treats water for use in the process.

The main emissions to air from site are from the combustion process. The principle releases are oxides of nitrogen and carbon, these are discharged through three 80m stacks at emission points A1, A2 and A3.

The schedules specify the changes made to the permit.

The status log of a permit sets out the permitting history, including any changes to the permit reference number.

<b>Status log of the permit</b>		
<b>Description</b>	<b>Date</b>	<b>Comments</b>
Application received BV3006IN	22/07/03	Duly made
Request to extend determination	12/11/03	Request accepted 18/11/03
Permit determined BV3006IN	05/03/04	Permit issued to Seabank power Limited.
Variation number EA/PPC/ NP3739SQ (Regulation 17(5) variation)	26/11/04	Variation notice served to introduce the appropriate monitoring and reporting requirements for the large Combustion Plant directive (2001/80/EC)
Regulation 60 Notice sent to the Operator	11/12/14	Issue of a Notice under Regulation 60(1) of the EPR. Environment Agency Initiated review and variation to vary the permit under IED to implement the special provisions for LCP under Chapter III, introducing new Emission Limit Values (ELVs) applicable to LCP, referred to in Article 30(2) and set out in Annex V. The permit is also updated to modern conditions.
Regulation 60 Notice response	31/03/15	Response received from the Operator.
Additional information received	30/9/15	Updated site plan
Additional information received	10/10/15	Confirming that the proposed new build black start facility is likely to perform a commercial operation as well as providing the black start function.
Additional information received	07/12/15	Clarification of parameters used to define the start-up and shutdown definitions.
Variation determined EPR/BV3006IN/V003 (PAS Billing ref: UP3432AV)	17/12/16	Varied and consolidated permit issued in modern condition format. Variation effective from 01/01/2016.

End of introductory note

# Notice of variation and consolidation

## The Environmental Permitting (England and Wales) Regulations 2010

The Environment Agency in exercise of its powers under regulation 20 of the Environmental Permitting (England and Wales) Regulations 2010 varies and consolidates

### Permit number

**EPR/BV3006IN**

### Issued to

**Seabank Power Limited.** (“the operator”)

whose registered office is

**Seabank Power Limited.  
Severn Road  
Hallen  
Bristol  
BS10 7SP**

company registration number 02591188

to operate a regulated facility at

**Seabank Power Station  
Severn Road  
Hallen  
Bristol  
BS10 7SP**

to the extent set out in the schedules.

The notice shall take effect from 01/01/2016

<b>Name</b>	<b>Date</b>
<b>Tom Swift</b>	<b>17/12/2015</b>

Authorised on behalf of the Environment Agency

## **Schedule 1**

All conditions have been varied by the consolidated permit as a result of an Environment Agency initiated variation.

## **Schedule 2 – consolidated permit**

Consolidated permit issued as a separate document.

# Permit

## The Environmental Permitting (England and Wales) Regulations 2010

### Permit number

**EPR/BV3006IN**

This is the consolidated permit referred to in the variation and consolidation notice for application EPR/BV3006IN/V003 authorising,

**Seabank Power Limited.** (“the operator”),

whose registered office is

**Seabank Power Limited.**

**Severn Road**

**Hallen**

**Bristol**

**BS10 7SP**

company registration number 02591188

to operate an installation at

**Seabank Power Station**

**Severn Road**

**Hallen**

**Bristol**

**BS10 7SP**

to the extent authorised by and subject to the conditions of this permit.

Name	Date
Tom Swift	17/12/2015

Authorised on behalf of the Environment Agency

# Conditions

## 1 Management

### 1.1 General management

1.1.1 The operator shall manage and operate the activities:

- (a) in accordance with a written management system that identifies and minimises risks of pollution, including those arising from operations, maintenance, accidents, incidents, non-conformances, closure and those drawn to the attention of the operator as a result of complaints; and
- (b) using sufficient competent persons and resources.

1.1.2 Records demonstrating compliance with condition 1.1.1 shall be maintained.

1.1.3 Any person having duties that are or may be affected by the matters set out in this permit shall have convenient access to a copy of it kept at or near the place where those duties are carried out.

### 1.2 Energy efficiency

1.2.1 The operator shall:

- (a) take appropriate measures to ensure that energy is used efficiently in the activities;
- (b) take appropriate measures to ensure the efficiency of energy generation at the permitted installation is maximised;
- (c) review and record at least every four years whether there are suitable opportunities to improve the energy efficiency of the activities; and
- (d) take any further appropriate measures identified by a review.

### 1.3 Efficient use of raw materials

1.3.1 The operator shall:

- (a) take appropriate measures to ensure that raw materials and water are used efficiently in the activities;
- (b) maintain records of raw materials and water used in the activities;
- (c) review and record at least every four years whether there are suitable alternative materials that could reduce environmental impact or opportunities to improve the efficiency of raw material and water use; and
- (d) take any further appropriate measures identified by a review.

### 1.4 Avoidance, recovery and disposal of wastes produced by the activities

1.4.1 The operator shall take appropriate measures to ensure that:

- (a) the waste hierarchy referred to in Article 4 of the Waste Framework Directive is applied to the generation of waste by the activities;
- (b) any waste generated by the activities is treated in accordance with the waste hierarchy referred to in Article 4 of the Waste Framework Directive; and
- (c) where disposal is necessary, this is undertaken in a manner which minimises its impact on the environment.

- 1.4.2 The operator shall review and record at least every four years whether changes to those measures should be made and take any further appropriate measures identified by a review.

## **2 Operations**

### **2.1 Permitted activities**

- 2.1.1 The operator is only authorised to carry out the activities specified in schedule 1 table S1.1 (the “activities”).

### **2.2 The site**

- 2.2.1 The activities shall not extend beyond the site, being the land shown edged in green on the site plan at schedule 7 to this permit.

### **2.3 Operating techniques**

- 2.3.1 The activities shall, subject to the conditions of this permit, be operated using the techniques and in the manner described in the documentation specified in schedule 1, table S1.2, unless otherwise agreed in writing by the Environment Agency.
- 2.3.2 For the following activities referenced in schedule 1, table S1.1: LCP 313, LCP 314, LCP 315 and LCP 409 the OCGT, without prejudice to condition 2.3.1, the activities shall be operated in accordance with the “Electricity Supply Industry IED Compliance Protocol for Utility Boilers and Gas Turbines” revision 1 dated February 2015 or any later version unless otherwise agreed in writing by the Environment Agency.
- 2.3.3 If notified by the Environment Agency that the activities are giving rise to pollution, the operator shall submit to the Environment Agency for approval within the period specified, a revision of any plan or other documentation (“plan”) specified in schedule 1, table S1.2 or otherwise required under this permit which identifies and minimises the risks of pollution relevant to that plan, and shall implement the approved revised plan in place of the original from the date of approval, unless otherwise agreed in writing by the Environment Agency.
- 2.3.4 Any raw materials or fuels listed in schedule 2 table S2.1 shall conform to the specifications set out in that table.
- 2.3.5 For the following activities referenced in schedule 1, table S1.1: LCP 313, LCP 314, LCP 315 and LCP 409. The end of the start up period and the start of the shutdown period shall conform to the specifications set out in Schedule 1, tables S1.2 and S1.5
- 2.3.6 For the following activities referenced in schedule 1, table S1.1: the OCGT plant activity A4 LCP No. 409 shall not operate for more than 500 hours per year.
- 2.3.7 The operator shall ensure that where waste produced by the activities is sent to a relevant waste operation, that operation is provided with the following information, prior to the receipt of the waste:
- (a) the nature of the process producing the waste;
  - (b) the composition of the waste;
  - (c) the handling requirements of the waste;
  - (d) the hazardous property associated with the waste, if applicable; and
  - (e) the waste code of the waste.
- 2.3.8 The operator shall ensure that where waste produced by the activities is sent to a landfill site, it meets the waste acceptance criteria for that landfill.



2.3.9 For the following activities referenced in schedule 1, table S1.1: LCP 409 the black start generator activity A4. The following conditions apply where there is a malfunction or breakdown of any abatement equipment:

Unless otherwise agreed in writing by the Environment Agency:

- (i) if a return to normal operations is not achieved within 24 hours, the operator shall reduce or close down operations, or shall operate the activities using low polluting fuels;
- (ii) the cumulative duration of breakdown in any 12-month period shall not exceed 120 hours; and
- (iii) the cumulative duration of malfunction in any 12-month period shall not exceed 120 hours

## **2.4 Improvement programme**

2.4.1 The operator shall complete the improvements specified in schedule 1 table S1.3 by the date specified in that table unless otherwise agreed in writing by the Environment Agency.

2.4.2 Except in the case of an improvement which consists only of a submission to the Environment Agency, the operator shall notify the Environment Agency within 14 days of completion of each improvement.

## **2.5 Pre-operational conditions**

2.5.1 The activities shall not be brought into operation until the measures specified in schedule 1 table S1.4 have been completed.

# **3 Emissions and monitoring**

## **3.1 Emissions to water, air or land**

3.1.1 There shall be no point source emissions to water, air or land except from the sources and emission points listed in schedule 3 tables S3.1, and S3.2

3.1.2 The limits given in schedule 3 shall not be exceeded.

3.1.3 Periodic monitoring shall be carried out at least once every 5 years for groundwater and 10 years for soil, unless such monitoring is based on a systematic appraisal of the risk of contamination.

## **3.2 Emissions of substances not controlled by emission limits**

3.2.1 Emissions of substances not controlled by emission limits (excluding odour) shall not cause pollution. The operator shall not be taken to have breached this condition if appropriate measures, including, but not limited to, those specified in any approved emissions management plan, have been taken to prevent or where that is not practicable, to minimise, those emissions.

3.2.2 The operator shall:

- (a) if notified by the Environment Agency that the activities are giving rise to pollution, submit to the Environment Agency for approval within the period specified, an emissions management plan which identifies and minimises the risks of pollution from emissions of substances not controlled by emission limits;
- (b) implement the approved emissions management plan, from the date of approval, unless otherwise agreed in writing by the Environment Agency.

- 3.2.3 All liquids in containers, whose emission to water or land could cause pollution, shall be provided with secondary containment, unless the operator has used other appropriate measures to prevent or where that is not practicable, to minimise, leakage and spillage from the primary container.

### **3.3 Odour**

- 3.3.1 Emissions from the activities shall be free from odour at levels likely to cause pollution outside the site, as perceived by an authorised officer of the Environment Agency, unless the operator has used appropriate measures, including, but not limited to, those specified in any approved odour management plan, to prevent or where that is not practicable to minimise the odour.
- 3.3.2 The operator shall:
- (a) if notified by the Environment Agency that the activities are giving rise to pollution outside the site due to odour, submit to the Environment Agency for approval within the period specified, an odour management plan which identifies and minimises the risks of pollution from odour;
  - (b) implement the approved odour management plan, from the date of approval, unless otherwise agreed in writing by the Environment Agency.

### **3.4 Noise and vibration**

- 3.4.1 Emissions from the activities shall be free from noise and vibration at levels likely to cause pollution outside the site, as perceived by an authorised officer of the Environment Agency, unless the operator has used appropriate measures, including, but not limited to, those specified in any approved noise and vibration management plan to prevent or where that is not practicable to minimise the noise and vibration.
- 3.4.2 The operator shall:
- (a) if notified by the Environment Agency that the activities are giving rise to pollution outside the site due to noise and vibration, submit to the Environment Agency for approval within the period specified, a noise and vibration management plan which identifies and minimises the risks of pollution from noise and vibration;
  - (b) implement the approved noise and vibration management plan, from the date of approval, unless otherwise agreed in writing by the Environment Agency.

### **3.5 Monitoring**

- 3.5.1 The operator shall, unless otherwise agreed in writing by the Environment Agency, undertake the monitoring specified in the following tables in schedule 3 to this permit:
- (a) point source emissions specified in tables S3.1, and S3.2;
- 3.5.2 The operator shall maintain records of all monitoring required by this permit including records of the taking and analysis of samples, instrument measurements (periodic and continuous), calibrations, examinations, tests and surveys and any assessment or evaluation made on the basis of such data.
- 3.5.3 Monitoring equipment, techniques, personnel and organisations employed for the emissions monitoring programme and the environmental or other monitoring specified in condition 3.5.1 shall have either MCERTS certification or MCERTS accreditation (as appropriate), where available, unless otherwise agreed in writing by the Environment Agency.
- 3.5.4 Permanent means of access shall be provided to enable sampling/monitoring to be carried out in relation to the emission points specified in schedule 3 tables S3.1, and S3.2 unless otherwise agreed in writing by the Environment Agency.

## 3.6 Monitoring for the purposes of the Industrial Emissions Directive Chapter III

- 3.6.1 All monitoring required by this permit shall be carried out in accordance with the provisions of Annex V of the Industrial Emissions Directive.
- 3.6.2 If the monitoring results for more than 10 days a year are invalidated within the meaning set out in condition 3.6.7, the operator shall:
- (a) within 28 days of becoming aware of this fact, review the causes of the invalidations and submit to the Environment Agency for approval, proposals for measures to improve the reliability of the continuous measurement systems, including a timetable for the implementation of those measures; and
  - (b) implement the approved proposals.
- 3.6.3 Continuous measurement systems on emission points from the LCP shall be subject to quality control by means of parallel measurements with reference methods at least once every calendar year.
- 3.6.4 Unless otherwise agreed in writing by the Environment Agency in accordance with condition 3.6.5 below, the operator shall carry out the methods, including the reference measurement methods, to use and calibrate continuous measurement systems in accordance with the appropriate CEN standards.
- 3.6.5 If CEN standards are not available, ISO standards, national or international standards which will ensure the provision of data of an equivalent scientific quality shall be used, as agreed in writing with the Environment Agency.
- 3.6.6 Where required by a condition of this permit to check the measurement equipment, the operator shall submit a report to the Environment Agency in writing, within 28 days of the completion of the check.
- 3.6.7 Where Continuous Emission Monitors are installed to comply with the monitoring requirements in schedule 3, table S3.1; the Continuous Emission Monitors shall be used such that:
- (a) for the continuous measurement systems fitted to the LCP release points defined in Table S3.1 the validated hourly, monthly and daily averages shall be determined from the measured valid hourly average values after having subtracted the value of the 95% confidence interval;
  - (b) the 95% confidence interval for nitrogen oxides and sulphur dioxide of a single measured result shall be taken to be 20%;
  - (c) the 95% confidence interval for dust releases of a single measured result shall be taken to be 30%;
  - (d) the 95% confidence interval for carbon monoxide releases of a single measured result shall be taken to be 10%;
  - (e) an invalid hourly average means an hourly average period invalidated due to malfunction of, or maintenance work being carried out on, the continuous measurement system. However, to allow some discretion for zero and span gas checking, or cleaning (by flushing), an hourly average period will count as valid as long as data has been accumulated for at least two thirds of the period (40 minutes). Such discretionary periods are not to exceed more than 5 in any one 24-hour period unless agreed in writing. Where plant may be operating for less than the 24-hour period, such discretionary periods are not to exceed more than one quarter of the overall valid hourly average periods unless agreed in writing; and
  - (f) any day, in which more than three hourly average values are invalid shall be invalidated

## 4 Information

### 4.1 Records

4.1.1 All records required to be made by this permit shall:

- (a) be legible;
- (b) be made as soon as reasonably practicable;
- (c) if amended, be amended in such a way that the original and any subsequent amendments remain legible, or are capable of retrieval; and
- (d) be retained, unless otherwise agreed in writing by the Environment Agency, for at least 6 years from the date when the records were made, or in the case of the following records until permit surrender:
  - (i) off-site environmental effects; and
  - (ii) matters which affect the condition of the land and groundwater.

4.1.2 The operator shall keep on site all records, plans and the management system required to be maintained by this permit, unless otherwise agreed in writing by the Environment Agency.

### 4.2 Reporting

4.2.1 The operator shall send all reports and notifications required by the permit to the Environment Agency using the contact details supplied in writing by the Environment Agency.

4.2.2 A report or reports on the performance of the activities over the previous year shall be submitted to the Environment Agency by 31 January (or other date agreed in writing by the Environment Agency) each year. The report(s) shall include as a minimum:

- (a) a review of the results of the monitoring and assessment carried out in accordance with the permit including an interpretive review of that data;
- (b) the resource efficiency metrics set out in schedule 4 table S4.2;
- (c) the performance parameters set out in schedule 4 table S4.3 using the forms specified in table S4.4 of that schedule.
- (d) where condition 2.3.6 applies the hours of operation in any year;
- (e) where condition 2.3.9 applies, the cumulative duration of breakdown and cumulative duration of malfunction in any 12 month period.

4.2.3 Within 28 days of the end of the reporting period the operator shall, unless otherwise agreed in writing by the Environment Agency, submit reports of the monitoring and assessment carried out in accordance with the conditions of this permit, as follows:

- (a) in respect of the parameters and emission points specified in schedule 4 table S4.1;
- (b) for the reporting periods specified in schedule 4 table S4.1 and using the forms specified in schedule 4 table S4.4; and
- (c) giving the information from such results and assessments as may be required by the forms specified in those tables.

4.2.4 The operator shall, unless notice under this condition has been served within the preceding four years, submit to the Environment Agency, within six months of receipt of a written notice, a report assessing whether there are other appropriate measures that could be taken to prevent, or where that is not practicable, to minimise pollution.

- 4.2.5 Within 10 days of the notification of abatement equipment malfunction or breakdown (condition 2.3.9) the operator shall submit an Air Quality Risk Assessment as outlined in the IED Compliance Protocol (condition 2.3.2).

## 4.3 Notifications

- 4.3.1 In the event:

- (a) that the operation of the activities gives rise to an incident or accident which significantly affects or may significantly affect the environment, the operator must immediately—
  - (i) inform the Environment Agency,
  - (ii) take the measures necessary to limit the environmental consequences of such an incident or accident, and
  - (iii) take the measures necessary to prevent further possible incidents or accidents;
- (b) of a breach of any permit condition the operator must immediately—
  - (i) inform the Environment Agency, and
  - (ii) take the measures necessary to ensure that compliance is restored within the shortest possible time;
- (c) of a breach of permit condition which poses an immediate danger to human health or threatens to cause an immediate significant adverse effect on the environment, the operator must immediately suspend the operation of the activities or the relevant part of it until compliance with the permit conditions has been restored.
- (d) of any malfunction or breakdown of abatement equipment relating to condition 2.3.9, the operator shall notify the Environment Agency within 48 hours unless notification has already been made under (a) to (c) above.

- 4.3.2 Any information provided under condition 4.3.1 [(a)(i), 4.3.1 (b)(i) where the information relates to the breach of a condition specified in the permit, or 4.3.1(d) where the information relates to malfunction or breakdown of abatement equipment shall be confirmed by sending the information listed in schedule 5 to this permit within the time period specified in that schedule.

- 4.3.3 Where the Environment Agency has requested in writing that it shall be notified when the operator is to undertake monitoring and/or spot sampling, the operator shall inform the Environment Agency when the relevant monitoring and/or spot sampling is to take place. The operator shall provide this information to the Environment Agency at least 14 days before the date the monitoring is to be undertaken.

- 4.3.4 The Environment Agency shall be notified within 14 days of the occurrence of the following matters, except where such disclosure is prohibited by Stock Exchange rules:

Where the operator is a registered company:

- (a) any change in the operator's trading name, registered name or registered office address; and
- (b) any steps taken with a view to the operator going into administration, entering into a company voluntary arrangement or being wound up.

Where the operator is a corporate body other than a registered company:

- (c) any change in the operator's name or address; and
- (d) any steps taken with a view to the dissolution of the operator.

- 4.3.5 Where the operator proposes to make a change in the nature or functioning, or an extension of the activities, which may have consequences for the environment and the change is not otherwise the subject of an application for approval under the Regulations or this permit:
- (a) the Environment Agency shall be notified at least 14 days before making the change; and
  - (b) the notification shall contain a description of the proposed change in operation.
- 4.3.6 The Environment Agency shall be given at least 14 days notice before implementation of any part of the site closure plan.
- 4.3.7 Where the operator has entered into a climate change agreement with the Government, the Environment Agency shall be notified within one month of:
- (a) a decision by the Secretary of State not to re-certify the agreement;
  - (b) a decision by either the operator or the Secretary of State to terminate the agreement; and
  - (c) any subsequent decision by the Secretary of State to re-certify such an agreement.
- 4.3.8 The operator shall inform the Environment Agency in writing of the closure of any LCP within 28 days of the date of closure.

## **4.4 Interpretation**

- 4.4.1 In this permit the expressions listed in schedule 6 shall have the meaning given in that schedule.
- 4.4.2 In this permit references to reports and notifications mean written reports and notifications, except where reference is made to notification being made "immediately", in which case it may be provided by telephone.

# Schedule 1 – Operations

<b>Table S1.1 activities</b>			
<b>Activity reference</b>	<b>Activity listed in Schedule 1 of the EP Regulations</b>	<b>Description of specified activity</b>	<b>Limits of specified activity</b>
A1 GT11 LCP 313 module 1	Section 1.1 A(1) (a): Burning any fuel in an appliance with a rated thermal input of 50 megawatts or more.	LCP313 (module 1): Operation of a combined cycle gas turbine(CCGT) fired on natural gas, for the production of electricity.	From receipt of natural gas to discharge of exhaust gases, and the generation of electricity for export
A2 GT12 LCP 314 module 1		LCP314 (module 1): Operation of a combined cycle gas turbine(CCGT) fired on natural gas, for the production of electricity.	
A3 GT11 LCP 315 module 2		LCP315 (module 2): Operation of a combined cycle gas turbine(CCGT) fired on natural gas, for the production of electricity.	
A4 LCP (black start generator) LCP 409		LCP 409 (black start generator): Open cycle gas turbine (OCGT) providing a black start facility	
<b>Directly Associated Activity</b>			
A5	Operation of forced draft cooling towers	Hybrid cooling tower operations	CCGT , heat recovery on HRSG
A6	Operation of a water purification plant	Production of demineralised water from towns water	From receipt of raw materials, to production of demineralised water
A7	Water discharge to controlled waters	Discharge of turbine cooling water purge and process effluent	Emission to controlled waters via co-discharge with Avonmouth sewage treatment Plant at Grid reference ST 51900 80700
-	Surface water drainage	Site drainage	Handling and storage of site drainage until discharge to the site surface water system

<b>Table S1.2 Operating techniques</b>		
<b>Description</b>	<b>Parts</b>	<b>Date Received</b>
Application	(1) The Response to questions 2.1, 2.2, 2.3, 2.4, 2.5, 2.6, 2.8, 2.9, and 2.10 given in section B1 and B2 of Volume 1 of the application, together with the relevant appendices referred to therein. (2) Supplementary Information entitled "Emissions Inventory" pages 1 and 2 and Site Layout Plan Figure 2 version 2 supplied as part of the application, submitted with letter dated 15/07/03	22/07/03
Response to regulation 60(1) Notice – request for information dated 11/12/14	Compliance route and operating techniques identified in response to the questions listed below:- 2 -The compliance route selected for each LCP. 4 - The configuration of each LCP. 5- The net rated Thermal input of each LCP and the method by which it was derived. 6- The definition of the conditions that will define the start-up and shutdown points. 9- The proposed Emission Limit Values. 10- Monitoring requirements when the LCPs are fired on fuel other than Natural Gas.	Received 31/03/15
Additional information received	Updated site plan received by e mail	Received 30/09/15
Additional information received	E mail from operator confirming that the proposed new build black start facility (LCP 409) is likely to perform a commercial operation as well as providing the black start function.	10/10/15
Additional information received	Clarification of parameters used to define the start up and shut down definitions	07/12/15

<b>Table S1.3 Improvement programme requirements</b>		
<b>Reference</b>	<b>Requirement</b>	<b>Date</b>
IC1 (1.4.1.1 in permit BV3006IN)	The Operator shall make written proposals to the Agency to upgrade the gas turbine emission monitoring system as required to meet BAT standards.	Complete
IC2 (1.4.1.2 in permit BV3006IN)	The Operator shall carry out a noise monitoring survey at the installation for the purpose of adequately quantifying the noise impact of the black start generator LCP 409. The measurement methodology and appropriate receptor monitoring locations shall be agreed in writing with the Agency. The results of the survey shall be reported to the Agency in writing, together with any consequent proposals to meet BAT standards.	Superseded by this variation, This IC has been included in the requirements of PO1 table S1.4



<b>Table S1.3 Improvement programme requirements</b>		
<b>Reference</b>	<b>Requirement</b>	<b>Date</b>
IC3 (1.4.1.3 in permit BV3006IN)	The Operator shall carry out a review of the environmental implications of the proposal to operate the black start generator LCP 409, as a standing reserve for up to 3000 hrs per year. The results of the review shall be reported to the Agency in writing.	Superseded by this variation, This IC has been included in the requirements of PO 2 table S1.4
IC4 (1.4.1.4 in permit BV3006IN)	The Operator shall carry out a review of BAT and BPEO with regard to the emission of aqueous effluent from the gas turbine closed circuit ancillary cooling systems. The results of the survey shall be reported to the Agency in writing, together with any consequent proposals to meet BAT standards.	Complete
IC5 (1.4.1.5 in permit BV3006IN)	The Operator shall produce a revised Site Closure Plan addressing each of the items identified in the latest relevant Agency guidance document.	Complete
IC6 (1.4.1.6 in permit BV3006IN)	The Operator shall include within the Environmental Management system procedures to ensure a continuing high level of protection to the land under the installation.	Complete
IC7 (1.4.1.7 in permit BV3006IN)	The Operator shall make a written proposal to the agency specifying the scope, format and content of the annual report required to be produced under condition 4.1.3 (permit BV3006IN)	Complete
IC 8	The Operator shall propose a method of calculation of the annual releases of dust from release points A1, A2, A3, A9	Complete
IC 9	The operator shall write to the Environment Agency for approval if an increase in the ELV limits set in table S3.1 of this permit is sought to the allowable limits set out in IED Annex V, Part 1, and paragraph 6.  The written submission from the operator shall contain :- -verification of the efficiency quoted for the plant - An assessment of any efficiency gains that may be gained through the limit increase together with detailed proposals for validating this figure. - An assessment of the impact of those increased emission limits from site on any air quality objectives. - Any impact the increased emissions might have on local receptors.	6 months from permit issue date

<b>Table S1.3 Improvement programme requirements</b>		
<b>Reference</b>	<b>Requirement</b>	<b>Date</b>
IC 10	For LCPD LCP 265, 266 and 267 (now LCP 313, 314 and 315 under IED). Annual emissions of dust, sulphur dioxide and oxides of nitrogen including energy usage for the year 01/01/2015 to 31/12/2015 shall be submitted to the Environment Agency using form AAE1 via the NERP Registry	28/01/16

<b>Table S1.4 Pre-operational measures for future development</b>		
<b>Reference</b>	<b>Operation</b>	<b>Pre-operational measures</b>
PO 1	OCGT operation, activity A4 table S1.1 (Black Start Generator) LCP 409	<p>The operator shall supply details in writing for approval by the Environment Agency prior to operation of LCP 409 for the following items :-</p> <ul style="list-style-type: none"> <li>- plant design, including a BAT justification for the proposed design , the BAT justification should include the requirements of IC2 previously set in the permit.</li> <li>- operational methods and controls</li> <li>- define start-up and shutdown conditions</li> <li>- an updated site plan to include emission point A9 for the black start facility</li> </ul>
PO 2	OCGT operation, activity A4 table S1.1 (Black start generator) LCP 409	Operations shall not commence on LCP 409, until the operator has submitted a report in writing to the Environment Agency for approval, demonstrating compliance with Chapter III of the Industrial Emissions Directive, and has obtained written approval from the Environment Agency
PO 3	OCGT operation, activity A4 table S1.1 (Black start generator) LCP 409	<p>The operator shall supply details in writing for approval by the Environment Agency if the operator wishes to apply for LCP 409 to operate in excess of the restrictions imposed by permit condition 2.3.6</p> <ul style="list-style-type: none"> <li>- A BAT justification for the proposed operation, including any environmental impact assessments that may be relevant (previously considered under IC3), any such assessment should reference the BAT review conducted by DECC in 2015 for the review of OCGT operations in the Balancing Market.</li> <li>- Proposed Emission Limit Values for the plant and methods of emission monitoring to be conducted, these should be considered against the requirements of Annex V in chapter III of the IED</li> </ul>

<b>Table S1.5 Start-up and Shut-down thresholds</b>		
<b>Emission Point and Unit Reference</b>	<b>“Minimum start up load” Any two of the discrete processes to be met.</b>	<b>“Minimum shut-down load” Any two of the discrete processes to be met.</b>
A1 , LCP 313 , GT11 on module 1	<ol style="list-style-type: none"> <li>1. Flame signal on</li> <li>2. GT Outlet temperature reached set point</li> <li>3. GT Inlet Guide Vane greater than minimum setting</li> </ol>	<ol style="list-style-type: none"> <li>1. Flame signal on</li> <li>2. GT Outlet temperature less than set point</li> <li>3. GT Inlet Guide Vane at minimum setting</li> </ol>
A2, LCP 314 , GT12 on module 1	<ol style="list-style-type: none"> <li>1. Flame signal on</li> <li>2. GT Outlet temperature reached set point</li> <li>3. GT Inlet Guide Vane greater than minimum setting</li> </ol>	<ol style="list-style-type: none"> <li>1. Flame signal on</li> <li>2. GT Outlet temperature less than set point</li> <li>3. GT Inlet Guide Vane at minimum setting</li> </ol>
A3, LCP 315 , GT on module 2	<ol style="list-style-type: none"> <li>1. Flame signal on</li> <li>2. GT Outlet temperature reached set point</li> <li>3. GT Inlet Guide Vane greater than minimum setting</li> </ol>	<ol style="list-style-type: none"> <li>1. Flame signal on</li> <li>2. GT Outlet temperature less than set point</li> <li>3. GT Inlet Guide Vane at minimum setting</li> </ol>
A9 LCP 409, Black Start Generator	As defined by condition PO1 in Table S1.4	As defined by condition PO1 in Table S1.4

## Schedule 2 – Waste types, raw materials and fuels

Table S2.1 Raw materials and fuels	
Raw materials and fuel description	Specification
-	-

## Schedule 3 – Emissions and monitoring

Table S3.1 Point source emissions to air						
Emission point ref. & location	Parameter	Source	Limit (including unit)-these limits do not apply during start up or shut down.	Reference period	Monitoring frequency	Monitoring standard or method
A1 [Point A1 on site plan in Schedule 7]	Oxides of nitrogen (NO and NO <sub>2</sub> expressed as NO <sub>2</sub> )	LCP 313 Gas turbine fired on natural gas	54 mg/m <sup>3</sup>	Monthly mean of validated hourly averages	Continuous	BS EN 14181
A1 [Point A1 on site plan in Schedule 7]	Oxides of nitrogen (NO and NO <sub>2</sub> expressed as NO <sub>2</sub> )	LCP 313 Gas turbine fired on natural gas	60 mg/m <sup>3</sup>	Daily mean of validated hourly averages	Continuous	BS EN 14181
A1 [Point A1 on site plan in Schedule 7]	Oxides of nitrogen (NO and NO <sub>2</sub> expressed as NO <sub>2</sub> )	LCP 313 Gas turbine fired on natural gas	109 mg/m <sup>3</sup>	95% of validated hourly averages within a calendar year	Continuous	BS EN 14181
A1 [Point A1 on site plan in Schedule 7]	Oxides of nitrogen (NO and NO <sub>2</sub> expressed as NO <sub>2</sub> )	LCP 313 Gas turbine fired on natural gas	109 mg/m <sup>3</sup>	Validated Hourly average	Annually	Agreed in writing with the Environment Agency
A1 [point A1 on site plan in schedule 7]	Carbon monoxide	LCP 313 Gas turbine fired on natural gas	90 mg/m <sup>3</sup>	Monthly mean of validated hourly averages	Continuous	BS EN 14181
A1 [point A1 on site plan in schedule 7]	Carbon monoxide	LCP 313 Gas turbine fired on natural gas	100 mg/m <sup>3</sup>	Daily mean of validated hourly averages	Continuous	BS EN 14181

<b>Table S3.1 Point source emissions to air</b>						
<b>Emission point ref. &amp; location</b>	<b>Parameter</b>	<b>Source</b>	<b>Limit (including unit)-these limits do not apply during start up or shut down.</b>	<b>Reference period</b>	<b>Monitoring frequency</b>	<b>Monitoring standard or method</b>
A1 [point A1 on site plan in schedule 7]	Carbon monoxide	LCP 313 Gas turbine fired on natural gas	180 mg/m <sup>3</sup>	95% of validated hourly averages within a calendar year	Continuous	BS EN 14181
A1 [point A1 on site plan in schedule 7]	Carbon monoxide	LCP 313 Gas turbine fired on natural gas	180 mg/m <sup>3</sup>	Validated Hourly average	Annually	Agreed in writing with the Environment Agency
A1 [point A1 on site plan in schedule 7]	Sulphur dioxide	LCP 313 Gas turbine fired on natural gas	-	-	At least every 6 months	Concentration by calculation as agreed in writing with the Environment Agency
A1 [point A1 on site plan in schedule 7]	Dust	LCP 313 Gas turbine fired on natural gas	-	-	Annually by calculation	
A1 [point A1 on site plan in schedule 7]	Oxygen	LCP 313 Gas turbine fired on natural gas	-	-	Continuous as appropriate to reference	
A1 [point A1 on site plan in schedule 7]	Water vapour	LCP 313 Gas turbine fired on natural gas	-	-	Continuous as appropriate to reference	
A1 [point A1 on site plan in schedule 7]	Stack gas temperature	LCP 313 Gas turbine fired on natural gas	-	-	Continuous as appropriate to reference	Traceable to national standards

<b>Table S3.1 Point source emissions to air</b>						
<b>Emission point ref. &amp; location</b>	<b>Parameter</b>	<b>Source</b>	<b>Limit (including unit)-these limits do not apply during start up or shut down.</b>	<b>Reference period</b>	<b>Monitoring frequency</b>	<b>Monitoring standard or method</b>
A1 [point A1 on site plan in schedule 7]	Stack gas pressure	LCP 313 Gas turbine fired on natural gas	-	-	Continuous as appropriate to reference	Traceable to national standards
A1 [point A1 on site plan in schedule 7]	As required by the Method Implementation Document for BS EN 15259	LCP 313 Gas turbine fired on natural gas	-	-	Pre-operation and when there is a significant operational change	BS EN 15259
A2 [Point A2 on site plan in Schedule 7]	Oxides of nitrogen (NO and NO <sub>2</sub> expressed as NO <sub>2</sub> )	LCP 314 Gas turbine fired on natural gas	54 mg/m <sup>3</sup>	Monthly mean of validated hourly averages	Continuous	BS EN 14181
A2 [Point A2 on site plan in Schedule 7]	Oxides of nitrogen (NO and NO <sub>2</sub> expressed as NO <sub>2</sub> )	LCP 314 Gas turbine fired on natural gas	60 mg/m <sup>3</sup>	Daily mean of validated hourly averages	Continuous	BS EN 14181
A2 [Point A2 on site plan in Schedule 7]	Oxides of nitrogen (NO and NO <sub>2</sub> expressed as NO <sub>2</sub> )	LCP 314 Gas turbine fired on natural gas	109 mg/m <sup>3</sup>	95% of validated hourly averages within a calendar year	Continuous	BS EN 14181
A2 [Point A2 on site plan in Schedule 7]	Oxides of nitrogen (NO and NO <sub>2</sub> expressed as NO <sub>2</sub> )	LCP 314 Gas turbine fired on natural gas	109 mg/m <sup>3</sup>	Validated Hourly average	Annually	Agreed in writing with the Environment Agency
A2 [point A2 on site plan in schedule 7]	Carbon monoxide	LCP 314 Gas turbine fired on natural gas	90 mg/m <sup>3</sup>	Monthly Mean of validated hourly averages	Continuous	BS EN 14181

<b>Table S3.1 Point source emissions to air</b>						
<b>Emission point ref. &amp; location</b>	<b>Parameter</b>	<b>Source</b>	<b>Limit (including unit)-these limits do not apply during start up or shut down.</b>	<b>Reference period</b>	<b>Monitoring frequency</b>	<b>Monitoring standard or method</b>
A2 [point A2 on site plan in schedule 7]	Carbon monoxide	LCP 314 Gas turbine fired on natural gas	100 mg/m <sup>3</sup>	Daily mean of validated hourly averages	Continuous	BS EN 14181
A2 [point A2 on site plan in schedule 7]	Carbon monoxide	LCP 314 Gas turbine fired on natural gas	180 mg/m <sup>3</sup>	95% of validated hourly averages within a calendar year	Continuous	BS EN 14181
A2 [Point A2 on site plan in Schedule 7]	Carbon monoxide	LCP 314 Gas turbine fired on natural gas	180 mg/m <sup>3</sup>	Validated Hourly average	Annually	Agreed in writing with the Environment Agency
A2 [point A2 on site plan in schedule 7]	Sulphur dioxide	LCP 314 Gas turbine fired on natural gas	-	-	At least every 6 months	Concentration by calculation as agreed in writing with the Environment Agency
A2 [Point A2 on site plan in Schedule 7]	Sulphur dioxide	LCP 314 Gas turbine fired on natural gas	-	-	Annually by calculation	As agreed in writing with the Environment Agency
A2 [Point A2 on site plan in Schedule 7]	Dust	LCP 314 Gas turbine fired on natural gas	-	-	Annually by calculation	As agreed in writing with the Environment Agency
A2 [Point A2 on site plan in Schedule 7]	Oxygen	LCP 314 Gas turbine fired on natural gas	-	-	Continuous as appropriate to reference	



<b>Table S3.1 Point source emissions to air</b>						
<b>Emission point ref. &amp; location</b>	<b>Parameter</b>	<b>Source</b>	<b>Limit (including unit)-these limits do not apply during start up or shut down.</b>	<b>Reference period</b>	<b>Monitoring frequency</b>	<b>Monitoring standard or method</b>
A2 [Point A2 on site plan in Schedule 7]	Water vapour	LCP 314 Gas turbine fired on natural gas	-	-	Continuous as appropriate to reference	
A2 [Point A2 on site plan in Schedule 7]	Stack gas temperature	LCP 314 Gas turbine fired on natural gas	-	-	Continuous as appropriate to reference	Traceable to national standards
A2 [Point A2 on site plan in Schedule 7]	Stack gas pressure	LCP 314 Gas turbine fired on natural gas	-	-	Continuous as appropriate to reference	Traceable to national standards
A2 [Point A2 on site plan in Schedule 7]	As required by the Method Implementation Document for BS EN 15259	LCP 314 Gas turbine fired on natural gas	-	-	Pre-operation and when there is a significant operational change	BS EN 15259
A3 [Point A3 on site plan in Schedule 7]	Oxides of nitrogen (NO and NO <sub>2</sub> expressed as NO <sub>2</sub> )	LCP 315 Gas turbine fired on natural gas	54 mg/m <sup>3</sup>	Monthly mean of validated hourly averages	Continuous	BS EN 14181
A3 [Point A3 on site plan in Schedule 7]	Oxides of nitrogen (NO and NO <sub>2</sub> expressed as NO <sub>2</sub> )	LCP 315 Gas turbine fired on natural gas	60 mg/m <sup>3</sup>	Daily mean of validated hourly averages	Continuous	BS EN 14181
A3 [Point A3 on site plan in Schedule 7]	Oxides of nitrogen (NO and NO <sub>2</sub> expressed as NO <sub>2</sub> )	LCP 315 Gas turbine fired on natural gas	109 mg/m <sup>3</sup>	95% of validated hourly averages within a calendar year	Continuous	BS EN 14181

<b>Table S3.1 Point source emissions to air</b>						
<b>Emission point ref. &amp; location</b>	<b>Parameter</b>	<b>Source</b>	<b>Limit (including unit)-these limits do not apply during start up or shut down.</b>	<b>Reference period</b>	<b>Monitoring frequency</b>	<b>Monitoring standard or method</b>
A3 [Point A3 on site plan in Schedule 7]	Oxides of nitrogen (NO and NO <sub>2</sub> expressed as NO <sub>2</sub> )	LCP 315 Gas turbine fired on natural gas	109 mg/m <sup>3</sup>	Validated Hourly average	Annually	Agreed in writing with the Environment Agency
A3 [point A3 on site plan in schedule 7]	Carbon Monoxide	LCP No. 315 Gas turbine fired on natural gas	90 mg/m <sup>3</sup>	Monthly mean of validated hourly averages	Continuous	BS EN 14181
A3 [point A3 on site plan in schedule 7]	Carbon monoxide	LCP 315 Gas turbine fired on natural gas	100 mg/m <sup>3</sup>	Daily mean of validated hourly averages	Continuous	BS EN 14181
A3 [point A3 on site plan in schedule 7]	Carbon monoxide	LCP 315 Gas turbine fired on natural gas	180 mg/m <sup>3</sup>	95% of validated hourly averages within a calendar year	Continuous	BS EN 14181
A3 [point A3 on site plan in schedule 7]	Carbon monoxide	LCP 315 Gas turbine fired on natural gas	180 mg/m <sup>3</sup>	Validated Hourly average	Annually	Agreed in writing with the Environment Agency
A3 [point A3 on site plan in schedule 7]	Sulphur dioxide	LCP 315 Gas turbine fired on natural gas	-	-	At least every 6 months	Concentration by calculation as agreed in writing with the Environment Agency
A3 [Point A3 on site plan in Schedule 7]	Sulphur dioxide	LCP 315 Gas turbine fired on natural gas	-	-	Annually by calculation	As agreed in writing with the Environment Agency

<b>Table S3.1 Point source emissions to air</b>						
<b>Emission point ref. &amp; location</b>	<b>Parameter</b>	<b>Source</b>	<b>Limit (including unit)-these limits do not apply during start up or shut down.</b>	<b>Reference period</b>	<b>Monitoring frequency</b>	<b>Monitoring standard or method</b>
A3 [Point A3 on site plan in Schedule 7]	Dust	LCP 315 Gas turbine fired on natural gas	-	-	Annually by calculation	As agreed in writing with the Environment Agency
A3 [Point A3 on site plan in Schedule 7]	Oxygen	LCP 315 Gas turbine fired on natural gas	-	-	Continuous as appropriate to reference	
A3 [Point A3 on site plan in Schedule 7]	Water vapour	LCP 315 Gas turbine fired on natural gas	-	-	Continuous as appropriate to reference	
A3 [Point A3 on site plan in Schedule 7]	Stack gas temperature	LCP 315 Gas turbine fired on natural gas	-	-	Continuous as appropriate to reference	Traceable to national standards
A3 [Point A3 on site plan in Schedule 7]	Stack gas pressure	LCP 315 Gas turbine fired on natural gas	-	-	Continuous as appropriate to reference	Traceable to national standards
A3 [Point A3 on site plan in Schedule 7]	As required by the Method Implementation Document for BS EN 15259	LCP 315 Gas turbine fired on natural gas	-	-	Pre-operation and when there is a significant operational change	BS EN 15259
A9 [Point A9 location to be supplied as part of PO1]	Oxides of nitrogen (NO and NO <sub>2</sub> expressed as NO <sub>2</sub> )	LCP 409 black start generator	-	-	Concentration by calculation every 4380 operational hours or 2 years whichever is sooner	Agreed in writing with the Environment Agency

<b>Table S3.1 Point source emissions to air</b>						
<b>Emission point ref. &amp; location</b>	<b>Parameter</b>	<b>Source</b>	<b>Limit (including unit)-these limits do not apply during start up or shut down.</b>	<b>Reference period</b>	<b>Monitoring frequency</b>	<b>Monitoring standard or method</b>
A9 [Point A9 location to be supplied as part of PO1]	Sulphur dioxide	LCP 409 black start generator	-	-	Concentration by calculation every 4380 operational hours or 2 years whichever is sooner	Agreed in writing with the Environment Agency
A9 [Point A9 location to be supplied as part of PO1]	Dust	LCP No. 409 black start generator	-	-	Concentration by calculation every 4380 operational hours or 2 years whichever is sooner	Agreed in writing with the Environment Agency
A9 [Point A9 location to be supplied as part of PO1]	Carbon monoxide	LCP No. 409 black start generator	-	-	Concentration by calculation every 4380 operational hours or 2 years whichever is sooner	Agreed in writing with the Environment Agency

<b>Table S3.2 Point Source emissions to water (other than sewer) – emission limits and monitoring requirements</b>						
<b>Emission point ref. &amp; location</b>	<b>Parameter</b>	<b>Source</b>	<b>Limit (incl. unit)</b>	<b>Reference period</b>	<b>Monitoring frequency</b>	<b>Monitoring standard or method</b>
W1 on site plan in schedule 7 for onward co-discharge with STW outlet to Severn Estuary	pH	Cooling water blow down, site drainage and process effluent	6 to 9 pH	Continuous	Continuous	As agreed with Environment Agency
W1 on site plan in schedule 7 for onward co-discharge with STW outlet to Severn Estuary	Flow	Cooling water blow down, site drainage and process effluent	18,000 m <sup>3</sup>	Daily	Continuous	As agreed with Environment Agency
W1 on site plan in schedule 7 for onward co-discharge with STW outlet to Severn Estuary	Temperature	Cooling water blowdown, site drainage and process effluent	35 °C	Daily average	Continuous	As agreed with Environment Agency

**Table S3.2 Point Source emissions to water (other than sewer) – emission limits and monitoring requirements**

<b>Emission point ref. &amp; location</b>	<b>Parameter</b>	<b>Source</b>	<b>Limit (incl. unit)</b>	<b>Reference period</b>	<b>Monitoring frequency</b>	<b>Monitoring standard or method</b>
W1 on site plan in schedule 7 for onward co-discharge with STW outlet to Severn Estuary	Biochemical Oxygen Demand	Cooling water blow down, site drainage and process effluent	500 mg/l	Flow weighted daily average	Fortnightly	As agreed with Environment Agency
W1 on site plan in schedule 7 for onward co-discharge with STW outlet to Severn Estuary	Cadmium	Cooling water blow down, site drainage and process effluent	35 µg/l	Flow weighted daily average	monthly	As agreed with Environment Agency
W1 on site plan in schedule 7 for onward co-discharge with STW outlet to Severn Estuary	Mercury	Cooling water blow down, site drainage and process effluent	4 µg/l	Flow weighted daily average	monthly	Calculation as agreed with Environment Agency
W1 on site plan in schedule 7 for onward co-discharge with STW outlet to Severn Estuary	Sulphate	Cooling water blow down, site drainage and process effluent	1,500 mg/l	Flow weighted daily average	Fortnightly	As agreed with Environment Agency
W1 on site plan in schedule 7 for onward co-discharge with STW outlet to Severn Estuary	Suspended Solids	Cooling water blow down, site drainage and process effluent	500 mg/l	Flow weighted daily average	Fortnightly	As agreed with Environment Agency
W1 on site plan in schedule 7 for onward co-discharge with STW outlet to Severn Estuary	Oil or grease	Cooling water blow down, site drainage and process effluent	None visible	Spot sample	fortnightly	As agreed with Environment Agency



## Schedule 4 – Reporting

Parameters, for which reports shall be made, in accordance with conditions of this permit, are listed below.

<b>Parameter</b>	<b>Emission or monitoring point/reference</b>	<b>Reporting period</b>	<b>Period begins</b>
Oxides of nitrogen	A1, A2, A3	Every 3 months	1 January, 1 April, 1 July, 1 October
Carbon monoxide	A1, A2, A3	Every 3 months	1 January, 1 April, 1 July, 1 October
Sulphur dioxide	A1, A2, A3, A9	Every 6 months	1 January, 1 July
Dust	A1, A2, A3, A9	Every 6 months	1 January, 1 July
Oxides of nitrogen	A9	Every 2 years	1 January
Carbon Monoxide	A9	Every 2 years	1 January
Sulphur dioxide	A9	Every 2 years	1 January
Emissions to water Parameters as required by condition 3.5.1	W1	Every 3 months	1 January, 1 April, 1 July, 1 October

<b>Parameter</b>	<b>Units</b>
Electricity Exported	GWhr
Heat Exported	GWhr
Mechanical Power Provided	GWhr
Fossil Fuel Energy Consumption	GWhr
Non-Fossil Fuel Energy Consumption	GWhr
Annual Operating Hours	hr
Water Abstracted from Fresh Water Source	m <sup>3</sup>
Water Abstracted from Borehole Source	m <sup>3</sup>
Water Abstracted from Estuarine Water Source	m <sup>3</sup>
Water Abstracted from Sea Water Source	m <sup>3</sup>
Water Abstracted from Mains Water Source	m <sup>3</sup>
Gross Total Water Used	m <sup>3</sup>
Net Water Used	m <sup>3</sup>
Hazardous Waste Transferred for Disposal at another installation	t
Hazardous Waste Transferred for Recovery at another installation	t



<b>Parameter</b>	<b>Units</b>
Non-Hazardous Waste Transferred for Disposal at another installation	t
Non-Hazardous Waste Transferred for Recovery at another installation	t
Waste recovered to Quality Protocol Specification and transferred off-site	t
Waste transferred directly off-site for use under an exemption / position statement	t

<b>Parameter</b>	<b>Frequency of assessment</b>	<b>Units</b>
Thermal Input Capacity for each LCP	Annually	MW
Annual Fuel Usage for each LCP	Annually	TJ
Total Emissions to Air of NO <sub>x</sub> for each LCP	Annually	t
Total Emissions to Air of SO <sub>2</sub> for each LCP	Annually	t
Total Emissions to Air of dust for each LCP	Annually	t
Operating hours for each LCP	Annually	hr

<b>Media/ parameter</b>	<b>Reporting format</b>	<b>Starting Point</b>	<b>Agency recipient</b>	<b>Date of form</b>
Air & Energy	Form IED AR1 – SO <sub>2</sub> , NO <sub>x</sub> and dust mass emission and energy	01/01/16	National	31/12/15
LCP	Form IED HR1 – operating hours	01/01/16	National	31/12/15
Air	Form IED CON 2 – continuous monitoring	01/01/16	Area Office	31/12/15
CEMs	Form IED CEM – Invalidation Log	01/01/16	Area Office	31/12/15
Air	Form IED PM1 - discontinuous monitoring and load.	01/01/16	Area Office	31/12/15
LCP	Form IED BD1 - Cumulative annual rolling malfunction and breakdown hours	01/01/16	Area Office	31/12/15
Air	Form IED MF1 – pollutant concentrations when during any day with malfunction or breakdown of abatement plant	01/01/16	Area Office	31/12/15
Resource efficiency	Form REM1 – resource efficiency annual report	01/01/16	National	31/12/15
Water	Form water 1 or other form as agreed in writing by the Environment Agency	01/01/16	Area Office	31/12/15

# Schedule 5 – Notification

These pages outline the information that the operator must provide.

Units of measurement used in information supplied under Part A and B requirements shall be appropriate to the circumstances of the emission. Where appropriate, a comparison should be made of actual emissions and authorised emission limits.

If any information is considered commercially confidential, it should be separated from non-confidential information, supplied on a separate sheet and accompanied by an application for commercial confidentiality under the provisions of the EP Regulations.

## Part A

Permit Number	
Name of operator	
Location of Facility	
Time and date of the detection	

<b>(a) Notification requirements for any malfunction, breakdown or failure of equipment or techniques, accident, or emission of a substance not controlled by an emission limit which has caused, is causing or may cause significant pollution</b>	
<b>To be notified within 24 hours of detection</b>	
Date and time of the event	
Reference or description of the location of the event	
Description of where any release into the environment took place	
Substances(s) potentially released	
Best estimate of the quantity or rate of release of substances	
Measures taken, or intended to be taken, to stop any emission	
Description of the failure or accident.	

<b>(b) Notification requirements for the breach of a limit</b>	
<b>To be notified within 24 hours of detection unless otherwise specified below</b>	
Emission point reference/ source	
Parameter(s)	
Limit	
Measured value and uncertainty	
Date and time of monitoring	
Measures taken, or intended to be taken, to stop the emission	

Parameter	Notification period

<b>(c) Notification requirements for the detection of any significant adverse environmental effect</b>	
<b>To be notified within 24 hours of detection</b>	
Description of where the effect on the environment was detected	
Substances(s) detected	
Concentrations of substances detected	
Date of monitoring/sampling	

## **Part B – to be submitted as soon as practicable**

Any more accurate information on the matters for notification under Part A.	
Measures taken, or intended to be taken, to prevent a recurrence of the incident	
Measures taken, or intended to be taken, to rectify, limit or prevent any pollution of the environment which has been or may be caused by the emission	
The dates of any unauthorised emissions from the facility in the preceding 24 months.	

<b>Name*</b>	
<b>Post</b>	
<b>Signature</b>	
<b>Date</b>	

\* authorised to sign on behalf of the operator

## **Part C Malfunction or Breakdown of LCP abatement equipment**

Permit Number	
Name of operator	
Location of Facility	
LCP Number	
Malfunction or breakdown	
Date of malfunction or	

breakdown	
-----------	--

<b>(a) Notification requirements for any malfunction and breakdown of abatement equipment as defined by the Industrial Emission Directive*.</b>	
<b>To be notified within 48 hours of abatement equipment malfunction and breakdown</b>	
Time at which malfunction or breakdown commenced	
Time at which malfunction or breakdown ceased	
Duration of the breakdown event in hours and minutes	
Reasons for malfunction or breakdown	
Where the abatement plant has failed, give the hourly average concentration of all measured pollutants.	
Cumulative breakdown operation in current year (at end of present event)	
Cumulative malfunction operation in current year (at end of present event)	
<b>Name**</b>	
<b>Post</b>	
<b>Signature **</b>	
<b>Date</b>	

\* See section 3.6 and Appendix E of ESI Compliance Protocol for guidance

\*\* authorised to sign on behalf of the operator

## Schedule 6 – Interpretation

“accident” means an accident that may result in pollution.

“Air Quality Risk Assessment” has the meaning given in Annex D of IED Compliance Protocol for Utility Boilers and Gas Turbines.

“application” means the application for this permit, together with any additional information supplied by the operator as part of the application and any response to a notice served under Schedule 5 to the EP Regulations.

“authorised officer” means any person authorised by the Environment Agency under section 108(1) of The Environment Act 1995 to exercise, in accordance with the terms of any such authorisation, any power specified in section 108(4) of that Act.

“background concentration” means such concentration of that substance as is present in:

for emissions to surface water, the surface water quality up-gradient of the site; or

for emissions to sewer, the surface water quality up-gradient of the sewage treatment works discharge.

“base load” means: (i) as a mode of operation, operating for >4000hrs pa; and (ii) as a load, the maximum load under ISO conditions that can be sustained continuously, i.e. maximum continuous rating.

“Black Start” means the procedure to recover from a total or partial shutdown of the UK Transmission System which has caused an extensive loss of supplies. This entails isolated power stations being started individually and gradually being reconnected to other power stations and substations in order to form an interconnected system again.

“breakdown” has the meaning given in the ESI IED Compliance Protocol for Utility Boilers and Gas Turbines.

“calendar monthly mean” means the value across a calendar month of all validated hourly means.

“CEN” means Comité Européen de Normalisation.

“Combustion Technical Guidance Note” means IPPC Sector Guidance Note Combustion Activities, version 2.03 dated 27th July 2005 published by Environment Agency..

- “emissions to land” includes emissions to groundwater.

“Energy efficiency” the ISO base load net plant efficiency means the performance value established by acceptance testing following commissioning or performance testing following improvements made to the plant that could affect the efficiency.

“Energy efficiency” the annual net plant energy efficiency means the value calculated from the operational data collected over the year.

“EP Regulations” means The Environmental Permitting (England and Wales) Regulations SI 2010 No.675 and words and expressions used in this permit which are also used in the Regulations have the same meanings as in those Regulations.

“emissions of substances not controlled by emission limits” means emissions of substances to air, water or land from the activities, either from the emission points specified in schedule 3 or from other localised or diffuse sources, which are not controlled by an emission or background concentration limit.

“groundwater” means all water, which is below the surface of the ground in the saturation zone and in direct contact with the ground or subsoil.

“Industrial Emissions Directive” means DIRECTIVE 2010/75/EU OF THE EUROPEAN PARLIAMENT AND OF THE COUNCIL of 24 November 2010 on industrial emissions.

“large combustion plant” or “LCP” is a combustion plant or group of combustion plants discharging waste gases through a common windshaft or stack, where the total thermal input is 50 MW or more, based on net calorific value. The calculation of thermal input, excludes individual combustion plants with a rated thermal input below 15MW.

“malfunction” has the meaning given in the ESI IED Compliance Protocol for Utility Boilers and Gas Turbines.

“Mid-merit” means combustion plant operating between 1,500 and 4,000 hrs/yr.

“MCERTS” means the Environment Agency’s Monitoring Certification Scheme

“MCR” means maximum continuous rating.

“MSDL” means minimum shut-down load as defined in Implementing Decision 2012/249/EU.

“MSUL” means minimum start-up load as defined in Implementing Decision 2012/249/EU.

“Natural gas” means naturally occurring methane with no more than 20% by volume of inert or other constituents.

“ncv” means net calorific value.

“OCGT” means an open cycle gas turbine

“operational hours” are whole hours commencing from the first unit ending start up and ending when the last unit commences shut down.

“quarter” means a calendar year quarter commencing on 1 January, 1 April, 1 July or 1 October.

“recovery” means any of the operations provided for in Annex II to Directive 2008/98/EC of the European Parliament and of the Council on waste.

“SI” means site inspector.

“Waste code” means the six digit code referable to a type of waste in accordance with the List of Wastes (England) Regulations 2005, or List of Wastes (Wales) Regulations 2005, as appropriate, and in relation to hazardous waste, includes the asterisk.

Where a minimum limit is set for any emission parameter, for example pH, reference to exceeding the limit shall mean that the parameter shall not be less than that limit.

Unless otherwise stated, any references in this permit to concentrations of substances in emissions into air means:

- in relation to emissions from combustion processes, the concentration in dry air at a temperature of 273K, at a pressure of 101.3 kPa and with an oxygen content of 3% dry for liquid and gaseous fuels, 6% dry for solid fuels; and/or

in relation to emissions from gas turbine or compression ignition engine combustion processes, the concentration in dry air at a temperature of 273K, at a pressure of 101.3kPa and with an oxygen content of 15% dry for liquid and gaseous fuels;

“year” means calendar year ending 31 December.

# Schedule 7 – Site plan

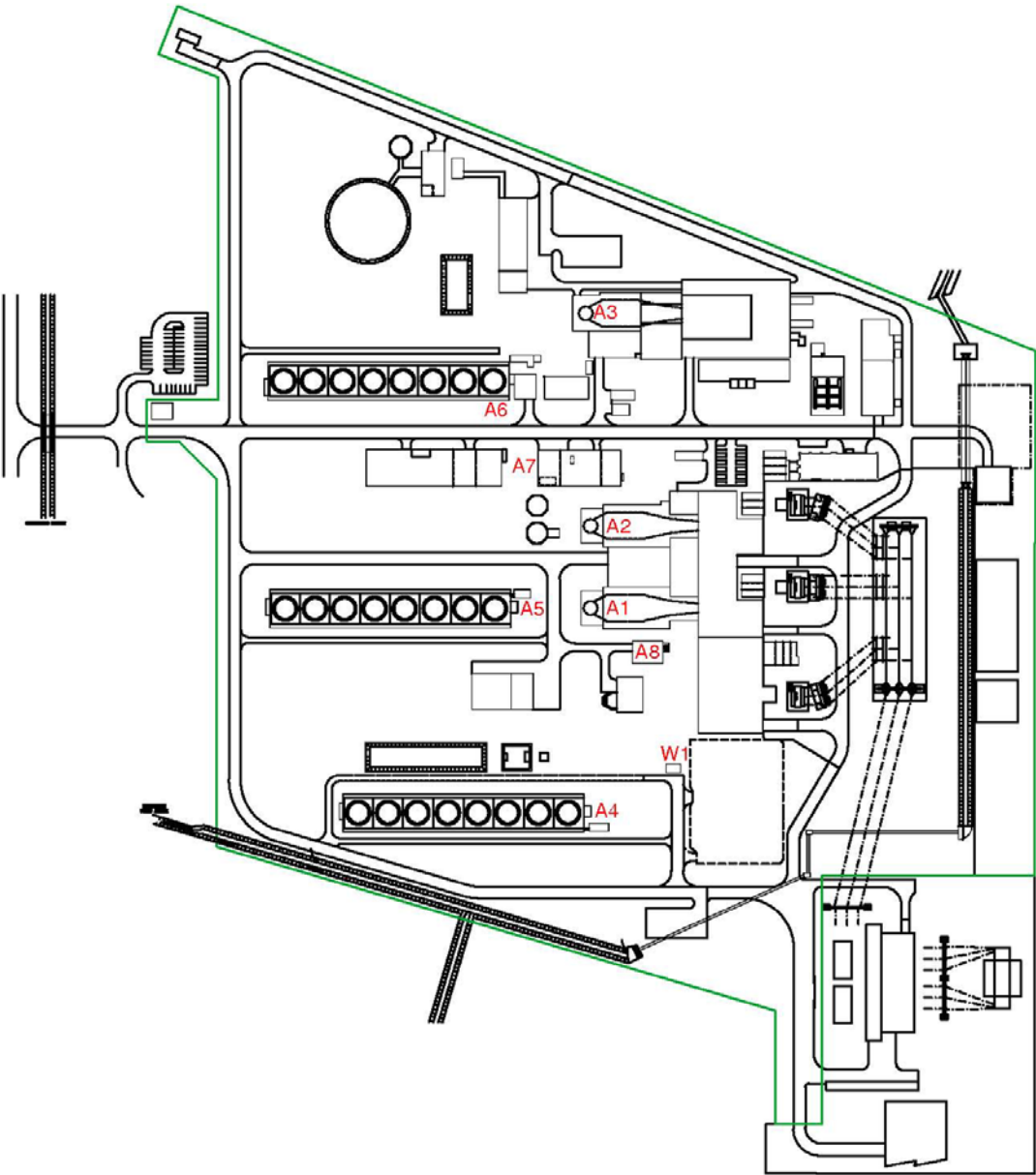

END OF PERMIT