

CONTENTS

SPECIAL BULLETINS

None

COMMERCIAL AIR TRANSPORT

FIXED WING

| | | | |
|------------------|--------|-----------|----|
| Airbus A319-131 | G-EUPZ | 15-Mar-09 | 1 |
| ATR 72-201 | EI-REH | 21-Oct-09 | 12 |
| Boeing 737-300 | G-CELI | 19-Oct-09 | 19 |
| Boeing 737-800 | EI-DLJ | 17-Jul-09 | 24 |
| DHC-8-402 Dash 8 | G-JEDI | 21-Dec-09 | 28 |

ROTORCRAFT

None

GENERAL AVIATION

FIXED WING

| | | | |
|----------------------------------|--------|-----------|----|
| Cessna 152 | G-FIFO | 04-Jun-10 | 34 |
| Cessna 172S Skyhawk | G-SOOA | 18-May-10 | 36 |
| Cessna F177RG Cardinal RG | G-BFPZ | 29-Mar-09 | 38 |
| DH82A Tiger Moth | G-ALWW | 21-Apr-10 | 43 |
| Diamond DA 42 Twin Star | G-CDKR | 24-Mar-10 | 44 |
| Jabiru J400 | G-CDLS | 19-May-10 | 46 |
| Mooney M20F Executive | G-CEJN | 08-Aug-09 | 49 |
| Pierre Robin HR100/210 Safari II | G-BLWF | 17-Apr-10 | 53 |
| Reims Cessna F172F Skyhawk | G-ASWL | 03-Mar-10 | 55 |
| Robin DR400/180 Regent | G-CBMT | 09-May-10 | 57 |
| Streak Shadow SA | G-WYAT | 04-Apr-10 | 59 |
| Yak-50 | G-YAKK | 10-Apr-10 | 60 |

ROTORCRAFT

| | | | |
|-------------|--------|-----------|----|
| Hughes 369E | G-VICE | 24-May-10 | 62 |
|-------------|--------|-----------|----|

SPORT AVIATION / BALLOONS

| | | | |
|-------------------------------------|--------|-----------|----|
| Aeroprakt A22 Foxbat | G-CWTD | 01-May-10 | 64 |
| EV-97 TeamEurostar UK | G-CEBP | 24-Apr-10 | 65 |
| Flight Design CTSW | G-CEKD | 11-Apr-10 | 66 |
| Ikarus C42 FB100 | G-HIJN | 09-Apr-10 | 67 |
| Mainair Blade 912 | G-BZFS | 10-Apr-10 | 68 |
| Montgomerie-Bensen B8MR | G-BIPY | 11-Oct-09 | 70 |
| P&M Aviation Ltd Flight Design CTSW | G-VINH | 12-Aug-09 | 76 |
| Rotorsport UK MT-03 gyroplane | G-CFCG | 06-Mar-10 | 87 |
| Savannah VG Jabiru(1) microlight | G-CFSX | 31-May-10 | 88 |
| Sky 260-24 hot air balloon | G-KTKT | 13-Aug-09 | 89 |

CONTENTS (Continued)

ADDENDA and CORRECTIONS

| | | | |
|------------------------|--------|-----------|----|
| Cessna F177RG Cardinal | G-BFPZ | 24-Apr-08 | 92 |
| Cyclone AX3/503 | G-MYFZ | 17-Oct-08 | 93 |

| | |
|--|----|
| List of recent aircraft accident reports issued by the AAIB (ALL TIMES IN THIS BULLETIN ARE UTC) | 94 |
|--|----|

SERIOUS INCIDENT

| | | |
|--|---|-------------------|
| Aircraft Type and Registration: | Airbus A319-131, G-EUPZ | |
| No & Type of Engines: | 2 International Aero Engine V2522-A5 turbofan engines | |
| Year of Manufacture: | 2001 | |
| Date & Time (UTC): | 15 March 2009 at 1935 hrs | |
| Location: | London Heathrow Airport | |
| Type of Flight: | Commercial Air Transport (Passenger) | |
| Persons on Board: | Crew - 6 | Passengers - 87 |
| Injuries: | Crew - None | Passengers - None |
| Nature of Damage: | Damage due to overheat in the area behind flight deck panel 123VU | |
| Commander's Licence: | Airline Transport Pilot's Licence | |
| Commander's Age: | 34 years | |
| Commander's Flying Experience: | 6,929 hours (of which 77 were on type) Last 90 days - 116 hours Last 28 days - 39 hours | |
| Information Source: | AAIB Field Investigation | |

Synopsis

Following the start of engine No 1, and as generator No 1 came on line, the commander's primary flight display (PFD) and navigation display (ND) blanked and the faults AC BUS 1, FWS FWC 1 and ELEC GEN 1 displayed on the Electronic Centralised Aircraft Monitoring system (ECAM). The crew carried out the ECAM drills and reset generator No 1, after which they heard a loud noise from behind the right circuit breaker (CB) panel, on the flight deck, and noticed a slight smell of electrical burning.

Subsequent investigation revealed evidence of a significant electrical overheat in the area behind the right CB panel. The initiation of the electrical fault and

subsequent overheating could not be fully established, but was considered to be most likely due to the presence of a loose article. The presence of dust in the area was also considered to be a contributory factor.

History of the flight

The crew reported for duty at 1810 hrs for a flight from Heathrow Airport to Edinburgh and completed their normal aircraft preparation checks, including a visual check of the flight deck CB panels, with nothing unusual being noted. The aircraft pushed back at 1930 hrs, by which time it was dark.

After the 'before start checks' had been completed

the co-pilot successfully started engine No 2 and then commenced the start of engine No 1. At the point that the crew expected generator No 1 to come online, the commander's PFD and ND both blanked, the master caution aural warning sounded, the cockpit overhead lights appeared to dim and the cabin lights also dimmed. The co-pilot checked the engine parameters, which were stable at ground idle and appeared normal.

The ECAM displayed an AC BUS 1 fault message and an associated fault checklist, which the crew actioned; this included placing the avionic cooling blower switch to OVERRIDE. They cleared this fault from the ECAM, revealing a FWS FWC 1 fault message. This required no crew actions so they cleared this fault, to then reveal an ELEC GEN 1 fault and another checklist which instructed them to reset generator No 1. They switched generator No 1 OFF using the switch on the overhead panel, and after a few seconds switched it back ON. On doing so, there was a loud noise that emanated from behind the right CB panel situated behind the co-pilot's seat. The crew then became aware of a notable, but not overbearing, 'electrical' burning smell; they looked for signs of smoke, of which there were none, and the co-pilot used his torch to inspect the area the noise had come from. During this examination the crew did not notice any 'tripped' CBs, but they commented that they did not specifically look at the CBs nor did they inspect those that were hidden from view behind the sliding jump seat.

The commander declared a PAN to ATC, and instructed the ground crew to tow the aircraft back onto stand. The co-pilot shut down both engines, at which point (he later recalled) the flight deck lights returned to their normal level of brightness. The flight crew considered that the problem was transient in nature and in view of the lack of any signs of smoke they did not consider

an emergency evacuation was necessary, nor did they consider it was necessary to don their oxygen masks. After the aircraft returned onto the parking stand, the passengers disembarked normally via the air bridge. The crew remained on the aircraft, completed some paperwork and discussed the event with their company engineers.

The crew believed that after resetting generator No 1, they had made no further electrical system selections, other than selecting the avionic cooling fan blower to NORMAL just prior to leaving the aircraft. When the aircraft was back on its parking stand, external electrical power had been connected to the aircraft, but it was not selected and the APU generator was left running throughout.

Electrical system operation (Figure 1)

Alternating current (AC) electrical power on the Airbus A319 is normally provided by two engine-driven integrated drive generators (IDGs); each IDG can produce a 115/200 VAC, 3-phase 400 Hz supply to the electrical network. In addition, the APU has a 90 KVA generator that can produce a 115/200 VAC, 3-phase 400 Hz supply to the network. With the aircraft on the ground there is provision for the electrical power network to be supplied by an external power supply.

The AC electrical power network is split into three parts: network No 1, network No 2 and the Essential network. Each network consists of a series of electrical buses and contactors which distribute the electrical supplies from the various power sources; the AC Bus 1 is the primary bus for network No 1 and AC Bus 2 the primary bus for network No 2. Control of the networks and the generators is by three Generator Control Units (GCU); GCU1 controls IDG1 and network No 1,

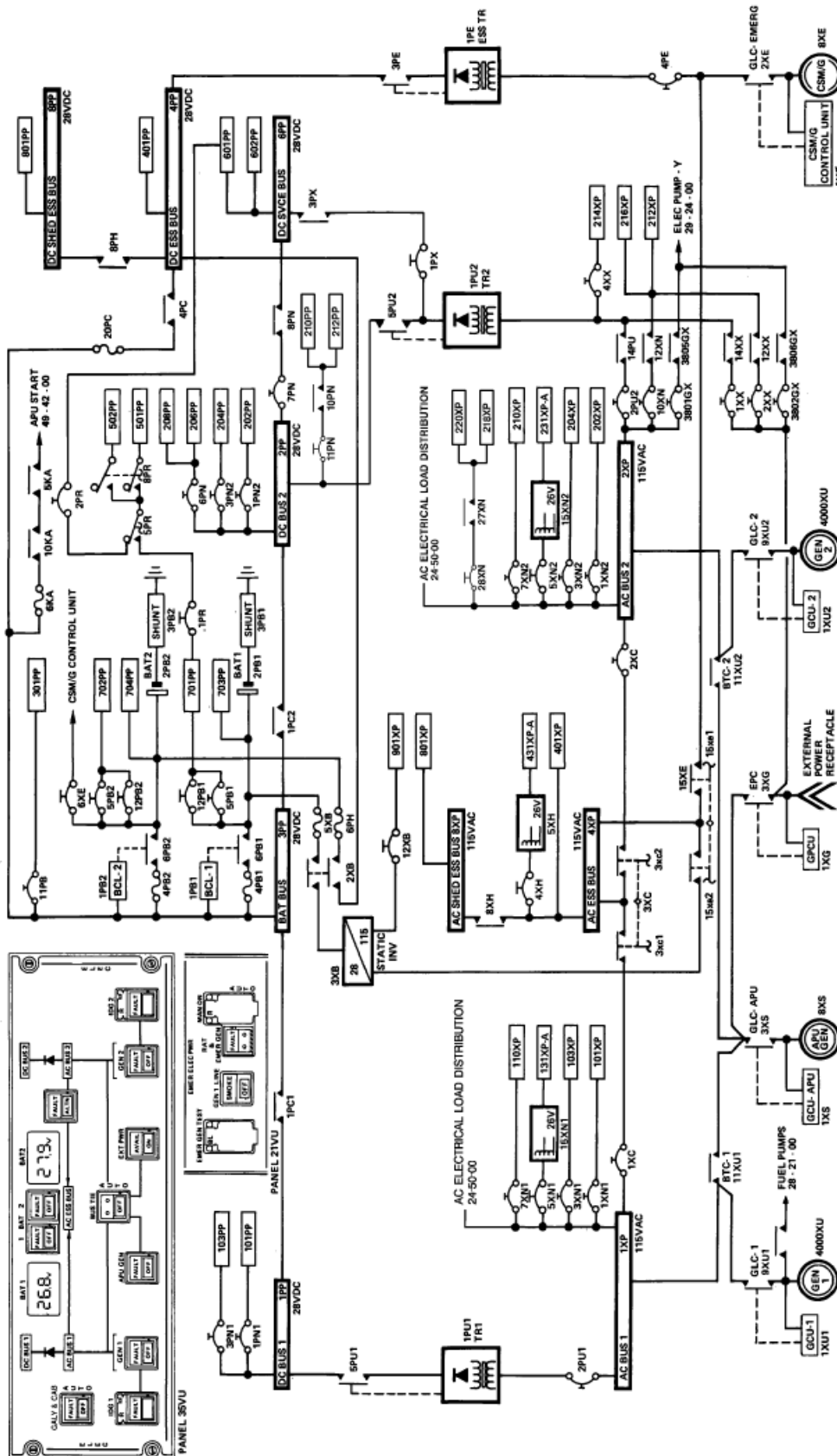

Figure 1
Electrical supply network

GCU2 controls IDG2 and network No 2, and the APU GCU controls the APU generator. Each GCU has four functions: the voltage regulation of the generator, the control and protection of the generator and the network, the control of the electrical system indications and a system test capability.

In normal operation, IDG 1 supplies network No 1 and IDG 2 supplies network No 2, with the APU and external power able to supply either network when required. Each generator is connected to its respective network buses via a Generator Load Contactor (GLC). When the generator is not providing power, Bus Tie Contactors (BTC) connect the other engine's generator, APU or external power to the network buses.

Each GCU continually monitors the generator and its electrical network so that, in the event that faults are detected, the system is protected by the isolation of the affected area. Differential Protection (DP) protects the network in the event of a short circuit or an unexpected current draw. The DP uses current transformers (CT) located within the network that monitor the currents flowing at these locations. There is one CT within the IDG, one downstream of the GLC and one downstream of the primary AC Bus supply. There are two DP protection areas, Zone 1 (DP1) which encompasses the generator and its electrical feeder cables, and Zone 2 (DP2) which includes the network between the GLC, BTC and the main AC distribution buses (Figure 2).

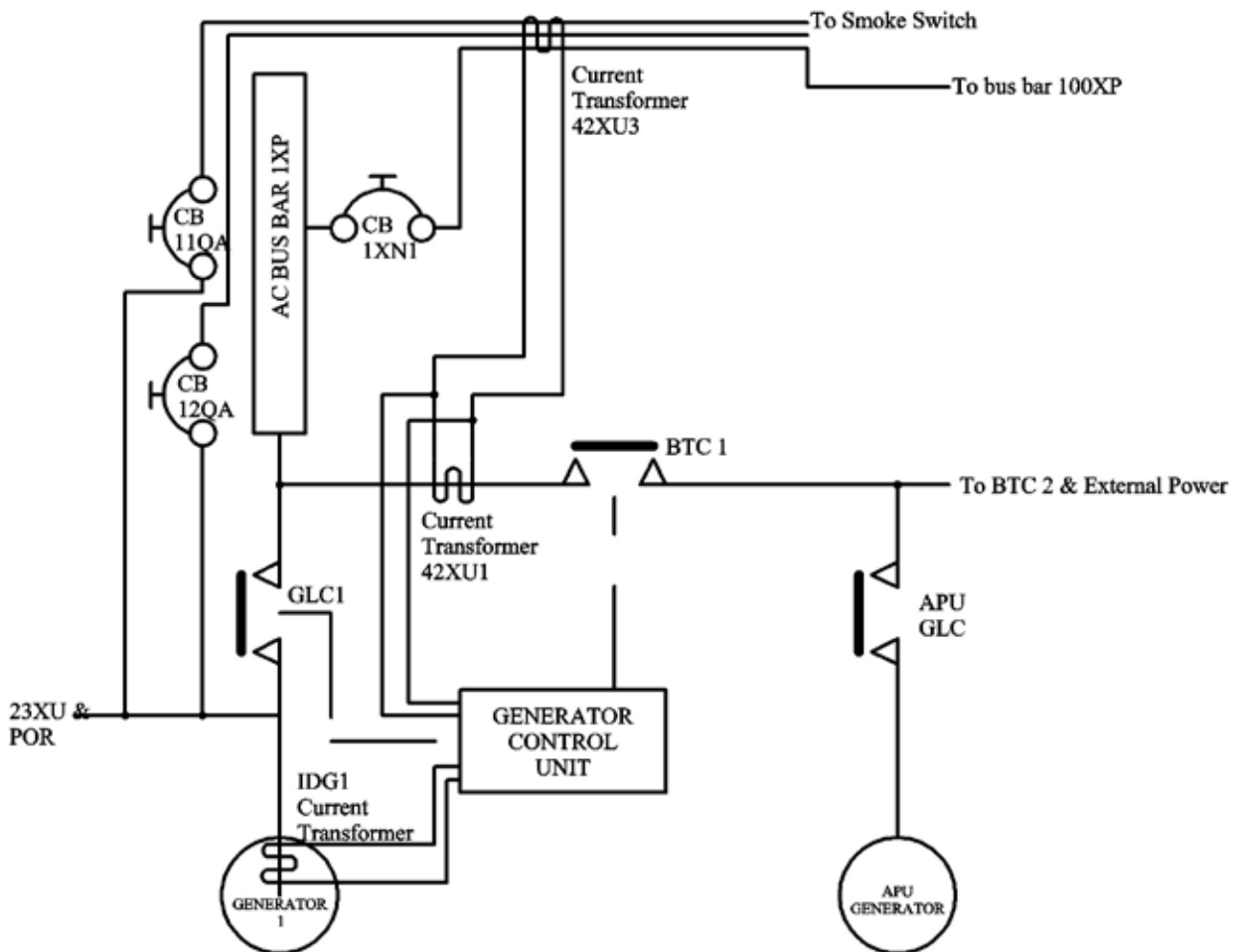

Figure 2
Simplified schematic of network No 1

If the GCU detects a difference in current between CTs of 45 A (+/- 5 A) for more than 37.5 ms (+/- 2.5 ms) then the DP is triggered and both the BTC and GLC controlled by the detecting GCU are opened. After a further 85 ms, the GCU measures the currents at the CTs again and if the difference in current no longer exists then the fault must have been within Zone 2, as the isolation of electrical power to the network has removed the unexpected currents. A DP2 results in the BTC and GLC remaining OPEN and the generator is de-excited. However, if the difference in current at the CTs is still detected, then the fault must have been within Zone 1 as the unexpected current draw must be from the generator. A DP1 results in the GLC remaining OPEN, but the BTC is allowed to CLOSE to connect the affected electrical network to the other engine's generator or the APU generator.

The flight crew can reset a generator fault, such as the GCU DP, by selecting the affected generator switch on the overhead electrical panel to OFF and then selecting it ON again. This reset can only be carried out twice, after which the GCU will prevent any further resets.

If the GCU detects an abnormal average current of greater than 20A at the time the generator becomes excited, and before the GCU closes the GLC, it will trigger the 'welded GLC' protection. This unexpected current is an indication that the GLC may have welded contacts, as a result the generator is de-excited, leading to the loss of power to the associated AC Bus, and a fault message is displayed on ECAM. The flight crew are not able to reset the generator if the GCU has triggered the 'welded GLC' protection.

On the A320 family of aircraft, power from generator No 1, taken upstream of the GLC1, provides electrical power to the fuel pumps in the event of the crew

having to carry out the electrical 'Smoke' procedure. This is to avoid the need to gravity feed fuel while the procedure is being undertaken and thus reduces flight crew workload. Protection of this circuit is by CB 11QA¹ and CB 12QA² and in normal operation there is no current flowing through these breakers. However, current will flow if the flight crew select the EMER ELEC GEN 1 LIN switch, on the overhead emergency electrical power panel, to OFF during the 'Smoke' procedure. As the power to CB 11QA and 12QA is supplied upstream of the GLC1, it is available whenever generator No 1 becomes excited and is independent of the GLC1 position.

The electrical power network buses are located in the 120VU cabinet, behind the co-pilot. AC Bus 1 and AC Bus 2 are mounted on panel 123VU (Figure 3), with AC Bus 1 to the left and AC Bus 2 to the right (facing forward). Directly below panel 123VU are the electrical contactors and feeder cables from the various generators. Cooling airflow through panel 123VU, and over the contactors, is achieved by the use of 'blowers' that draw air down through the panel via an orifice in the floor. In the event of a failure of AC Bus 1, the resulting ECAM checklist requires the avionic cooling blowers to be set to OVERRIDE, and as a result the forced airflow through cabinet 120VU ceases.

Recorded Information

Data was recovered from the Flight Data Recorder (FDR), Cockpit Voice Recorder (CVR) and the Quick Access Recorder (QAR). The recordings were combined in order to present a time-history of events during the engine start.

Footnote

- ¹ Panel 123VU position AD12 'L WING PUMP 1 STBY SPLY'.
- ² Panel 123VU position AE12 'R WING TK PUMP 1 STBY SPLY'.

The FDR recorded engine No 2 starting first, with its associated GLC 2 closing to allow power from the engine generator into network No 2 of the electrical system. A few seconds later, the engine No 1 master lever was selected to ON and the engine began to start. One minute later the FDR recorded a loss of AC Bus 1, the opening of BTC 1, a number of master cautions and a momentary loss of the AC Essential bus. The GLC 1 remained OPEN and the recorded electrical load for generator No 1 remained at zero.

The flight crew acknowledged the loss of the AC Bus 1 and around 70 seconds later, the generator No 1 reset was performed. This led to an interruption to the CVR power supply but once it resumed recording, a loud interference noise was recorded on all four channels for two seconds. The AC Bus 1 power supply was then restored by the closing of both the BTCs allowing network No 1 to be supplied by generator No 2. At this stage the crew reported smelling smoke and the aircraft returned to its parking stand.

An attempt was made to download the fault memory from the GCU1, however this was unsuccessful, although a test of the unit was satisfactory. Due to the short time between engine start and shutdown, the CFDIU did not recognise this event as a flight and therefore did not record any data in its memory, nor did it produce a post-flight report.

Aircraft examination

A visual inspection of the cockpit and the external faces of the CB panels did not reveal any signs of damage. On the rear right CB panel, 123VU (Figure 3), CB 11QA and 12QA had tripped and on opening the panel there was evidence that significant overheating had occurred, with extensive sooting. The fire damage was centred in the area around CB 11QA with damage to the AC Bus 1

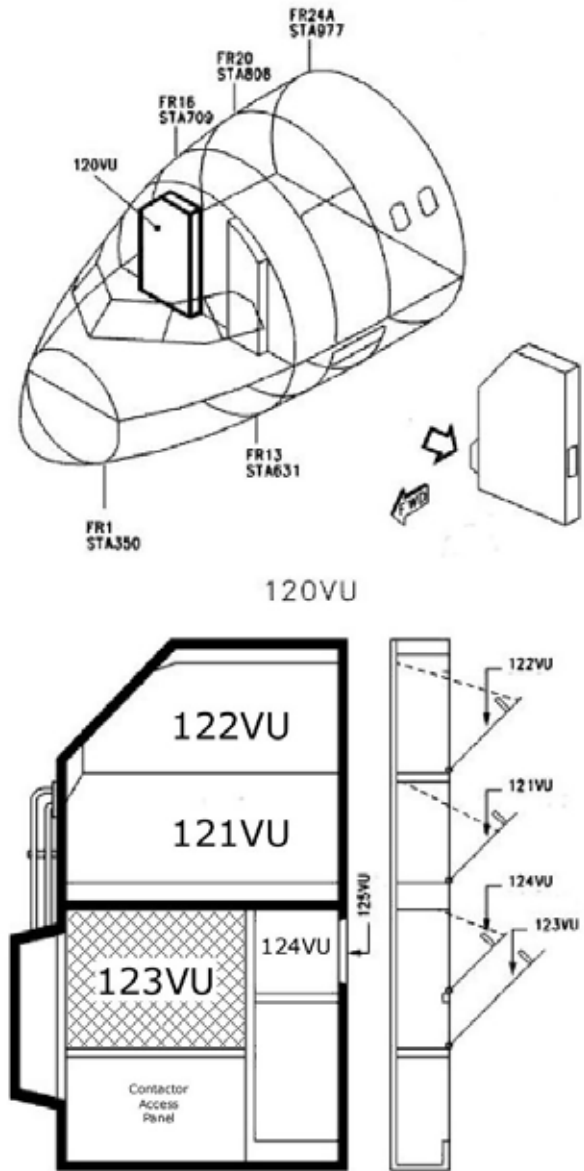

Figure 3

Cabinet 120VU and panel 123VU location

busbar that ran alongside these breakers. (Figures 4 and 5). The busbar had suffered extensive heat damage with areas of melting of the copper terminals.

The aluminium structure directly to the left of CB 11QA had melted, creating a 70 mm by 50 mm hole, with a heat-affected zone extending 150 mm by 100 mm (Figure 6). This had resulted in some light sooting in the area behind panel 124VU.



Figure 4

General view of damage to panel 123VU

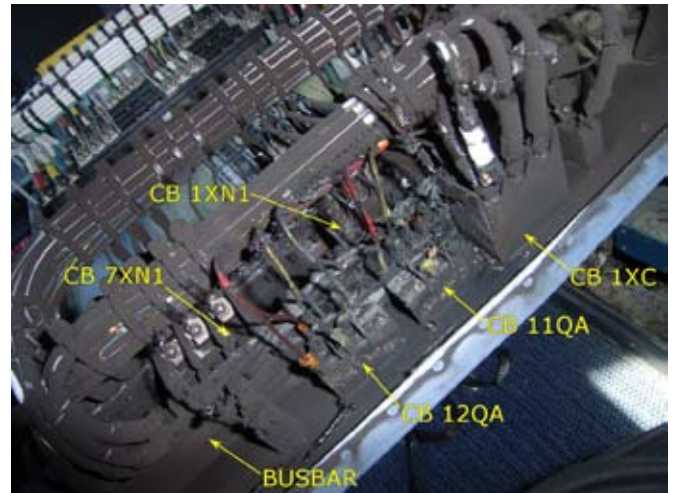

Figure 5

Damage to CB and AC Bus 1 busbar (panel 123VU)



Figure 6

Structural damage outboard of panel 123VU

As a result of the fire, molten debris had dropped down from 123VU and was found in the bottom left corner of the panel and in the area directly below 123VU. The

debris had also caused some scorching to the external faces of BTC 1 and GLC 1, which are mounted directly below 123VU.

Detailed aircraft examination

Panel 123VU was removed from the aircraft and taken to a specialist forensic laboratory for a detailed examination under AAIB supervision. The damage to AC Bus 1 was most severe directly behind CB 11QA, with erosion of the busbar terminals and burning and distortion of the busbar insulation material in this area.

There was evidence of damage from arcing and some fibrous deposits between phases on some of the AC Bus 1 exposed connections (Figure 7).

Two exposed terminals on AC Bus 1 had melted and there were ‘pin-like’ protrusions, which were products of the molten copper (Figure 8). A visual inspection of the unaffected wiring found it to be in a good condition and tests of the wiring did not show signs of degradation that could have caused the electrical faults or the fire. The remaining terminals and connections were found to be correctly installed and the examination did not reveal

the presence of foreign objects. All the affected CBs³ were tested and found to operate within the published specification.

The contactors BTC 1 and GLC 1, their mounting panel and generator No 1, were examined, tested and found to operate satisfactorily.

The soot around the panel consisted of carbon, fluorine, copper and zinc. All of these were consistent with the products of vaporised material and wiring insulation damage from the fire. The debris collected from around and below panel 123VU consisted of molten materials that could be accounted for from the materials used on the panel.

Dust contamination

During the detailed examination of panel 123VU, it became apparent that there was fibrous material, or ‘dust’, across various exposed busbar terminals. This ‘dust’ was sampled for its composition and assessed as to whether it could have been a factor in the electrical

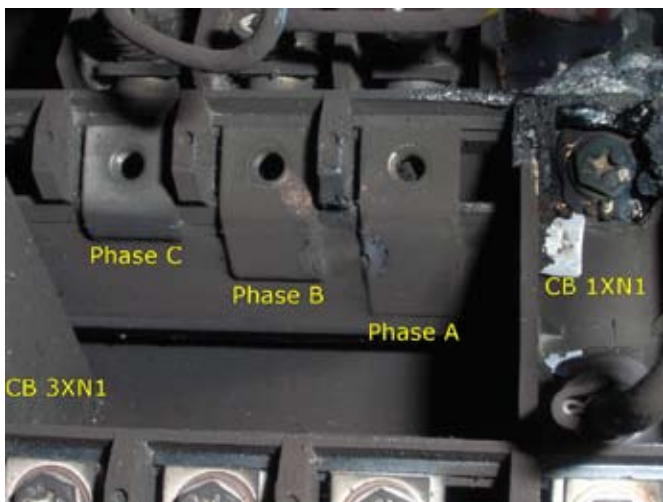

Figure 7
Exposed AC Bus 1 connections

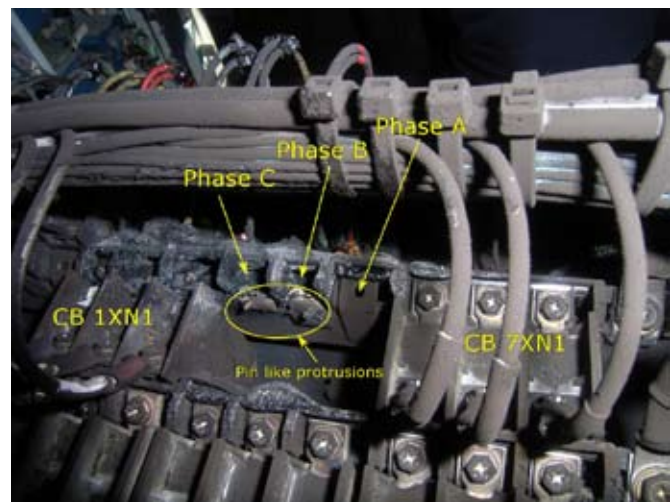

Figure 8
Exposed AC Bus 1 connections – pin-like protrusion

Footnote

³ CBs tested were 11QA, 12QA, 1XC, 1XN1, 23XU1, 7XN1, 3XN1.

faults or the fire. The dust contained fibres, consisting of small mineral fragments and metallic flakes (mainly steel), and organic flakes of skin. Chloride levels in the dust were found to be high, when compared to normal office dust, and the laboratory report commented that this would lead to an increase in its conductivity.

Tracking tests on the dust were carried out⁴ in a laboratory. Those tests carried out on 'dry' dust passed, however tests in which a conducting liquid was dropped onto the dust samples, placed on an acrylic sheet, failed with tracking and fire occurring after a few drops. It should be noted that, on examination of G-EUPZ, there was no evidence found of fluid contamination in the area of overheating.

Maintenance history

In January 2009 G-EUPZ underwent a major maintenance input, which included wiring changes and the installation and replacement of CBs in the area of panel 122VU, which is above 123VU. There was also a maintenance record that general cleaning of the wiring looms in the 120VU cabinet had been carried out. Since this maintenance input there were no records of further work or disturbance of the 120VU cabinet.

Electrical Wiring Interconnection Systems (EWIS)⁵

Following the accidents to a Boeing 747-131, N93119, near East Moriches, New York on July 17 1996 and a McDonnell Douglas MD-11, HB-IWF, near Peggy's Cove, Nova Scotia on 2 September 1998, the Federal Aviation Administration commissioned a study

ASTRAC⁶) which has led to the Ageing Transport System Program for Electrical Wiring Interconnection Systems (EWIS). As a result the EASA issued changes to Certification Specification (CS) 25, adding Subpart H entitled 'Electrical Wiring Interconnection Systems' in September 2008 and CS 25.1729, which requires instructions for continued airworthiness specifically for EWIS. EASA also issued an 'acceptable means of compliance' document⁷ for manufacturers, changes to CS Part M and Part 66 on requirements for personnel and training, and a retrospective requirement for type certificate holders to introduce improved maintenance and zonal inspection programmes of EWIS into the maintenance schedule prior to March 2011.

In May 2007, Airbus introduced changes to their aircraft maintenance planning documents for operators to comply with the EWIS requirements. These recommend the cleaning of the wiring installed in 120VU every 72 months and a general visual inspection of the wiring every 144 months. Aircraft operators are required to introduce these changes into their own approved maintenance schedules by March 2011. The operator of G-EUPZ trained its maintenance staff on the new EWIS maintenance and inspection procedures and introduced the new requirements into their schedule around September 2009.

Analysis

Due to the extent of local fire damage, and the lack of data from the GCU1 and the CFDIU, it was not possible fully to establish the initiating factor for the electrical fire behind panel 123VU. However, based on the available data and the examination of the aircraft, a possible sequence of events has been established, as well as the potential causal and contributory factors.

Footnote

Footnote

⁴ Conducted generally, and using test equipment for tests, to BS EN 60112:2003.

⁵ EWIS means any wire, wiring device, or combination of these, including termination devices, installed in any area of the aeroplane for the purpose of transmitting electrical energy. It includes wires, busbars, connectors and cable ties.

⁶ Ageing Transport Systems Rulemaking Advisory Committee

⁷ AMC 20-21 'Programme to enhance aeroplane Electrical Wiring Interconnection System (EWIS) maintenance'.

The damage from the fire was centred on CB 11QA and therefore it is most likely that this was the area where the electrical fault and the subsequent fire had initiated. Prior to the start of engine No 1, AC Bus 1 was being supplied by the APU generator though the closed BTC 1, with no reported faults. As engine No 1 started, generator No 1 started to provide electrical power to CB 11QA. This was prior to the closing of GLC1 and it was at this point that GCU1 detected a fault, causing BTC 1 to open and prevented GLC 1 from closing. This led to the loss of AC Bus 1 power and the associated ECAM fault messages and aural warnings. The electrical system response was indicative of a DP, triggered due to the detection of differing current flows in the electrical network. Following this initial event, BTC1, GLC1 were OPEN and the generator remained de-excited indicating that the GCU had detected a fault in Zone 2, and was either a fault somewhere within the electrical network or erroneous current flows in the network for less than 85 ms.

The only change in the electrical network, at the time of the engine No 1 start, was that its generator feeders and CBs 11QA and 12QA had become powered. These CBs are usually dormant and should not have been flowing any current unless there was a short, a fault with the CBs or the crew had operated the EMER ELEC GEN 1 LIN switch on the overhead panel. It is known that the switch was not operated and tests eliminated the possibility of a fault with the CBs, therefore it was possible that current was able to flow through the CB due to a short.

Following the first detected generator No 1 failure, the crew attempted a reset of the generator, as directed by the ECAM checklist, during which they were aware of a loud noise from behind the CB panel and a faint smell of electrical burning. It was also at this stage that the CVR recorded significant interference, all of which were

symptoms of electrical arcing. The GCU had reset the generator, which would have not been possible had it triggered the 'welded' GLC protection.

When generator No 1 first became excited a transient short or a short duration arc may have occurred between CB 11QA and AC Bus 1, thereby causing some localised damage to the wiring and the bus bar, leading to unexpected current flows in the network. At the reset of generator No 1, it was re-excited, electrical power was again fed to CB 11QA and BTC1 closed, restoring power to AC Bus 1. The initial damage may have led to further arcing as the electrical power was restored to the network.

The crew had already completed the ECAM checklist so the avionic cooling blower fan was now in OVERRIDE thereby removing the forced airflow through the 120VU cabinet. The arcing led to a highly ionised atmosphere behind 123VU, which was not dissipated by the airflow and would have contributed to further arcing. Dust was prevalent in the area behind the panel and on exposed phases on the AC bus bars. This would have contributed to the propagation of the fire by providing a combustible material and may also have contributed to the arcing as the 'creepage' distance between terminals was reduced by the contaminant.

From the recorded data it was concluded that the GCU 1 again triggered the DP and as the erroneous currents were still present after the initial 85 ms, evidenced by interference on the CVR for 2 seconds, the fault was probably detected as being in Zone 1. As a Zone 1 fault indicates a fault with the generator or its electrical feeders, the GLC1 remained OPEN, generator No 1 was de-excited, and BTC 1 CLOSED connecting AC Bus 1 to network No 2. Power then remained on AC Bus 1 with no further indication of arcing or fire, so the electrical

arcing and the associated fire was short-lived, but it had been very intense with temperatures in excess of 1084°C.

As no other physical reason for the electrical fault could be identified, it was possible that a conducting loose article had caused a short at the time that generator No 1 first came online. No loose article was found in the panel, however, it could have come from a number of sources and it is likely that it vaporised during the initial stages due of the fire. As a result it has not been possible

to determine how or when a loose article entered the affected area.

Safety actions

The introduction of the new EWIS requirements, and the associated training, already highlights the need for good housekeeping and cleanliness of electrical connection systems in aircraft; its introduction into scheduled maintenance should reduce recurrence of electrical faults from foreign objects and debris.

ACCIDENT

| | | |
|--|--|-------------------|
| Aircraft Type and Registration: | ATR 72-201, EI-REH | |
| No & Type of Engines: | 2 Pratt & Whitney Canada PW 124B turboprop engines | |
| Year of Manufacture: | 1990 | |
| Date & Time (UTC): | 21 October 2009 at 1030 hrs | |
| Location: | Stand 7, Manchester Airport | |
| Type of Flight: | Commercial Air Transport (Passenger) | |
| Persons on Board: | Crew - 4 | Passengers - 33 |
| Injuries: | Crew - None | Passengers - None |
| Nature of Damage: | Significant damage to propeller blades and stand infrastructure | |
| Commander's Licence: | Airline Transport Pilot's Licence | |
| Commander's Age: | 30 years | |
| Commander's Flying Experience: | 3,790 hours (of which 1,425 were on type) Last 90 days - 225 hours Last 28 days - 60 hours | |
| Information Source: | AAIB Field Investigation | |

Synopsis

Following an uneventful flight, the aircraft came to a halt on stand and the crew applied the parking brake. However, the aircraft subsequently started to move forward once more and, despite attempts to stop the aircraft by using the brakes, it continued to move until it struck a stand guidance mirror assembly. The investigation determined that a failure of a hydraulic fuse in the parking/emergency brake line had led to a loss of the brake accumulator hydraulic pressure.

History of the flight

The crew were operating the first of four scheduled sectors. Following an uneventful flight from Galway, Ireland to Manchester, the commander taxied the

aircraft towards Stand 7. Before turning onto the stand centreline, the flight crew checked that all brake pressures were indicating normally. Having drawn up to the correct stopping position on the stand, the commander set the parking brake before feathering both propellers. Ground crew approached the aircraft whilst the anti-collision lights were flashing and attached the fixed electrical power¹ cable. Although their procedures required them to insert chocks immediately on approaching the aircraft, they did not do so.

Footnote

¹ The fixed electrical power cable provides ground based electrical power for the aircraft.

The aircraft then started moving slowly forwards, so the ground crew ran clear. Both pilots attempted to stop the aircraft by applying the toe brakes, without success, after which the commander exercised the parking/emergency brake lever.

Recognising that the aircraft was not under control, the commander gave an 'alert call' to the cabin crew, and instructed the co-pilot to shut the engines down. The co-pilot shut the engines down, transmitted to ATC that the aircraft was in difficulties and requested the attendance of the fire and rescue service.

The aircraft rolled forward until the No 2 engine propeller struck a stand guidance mirror, provided to enable pilots to see the stop lines on the stand centreline. Both the mirror and propeller were damaged, with one propeller blade becoming lodged in the mirror assembly as the aircraft stopped moving. The fire and rescue service responded after a short delay, which was due to training exercises being conducted at the time of the accident.

Analysing the event later, both pilots recalled considering the possibility of using reverse thrust to attempt to halt the aircraft's movement and perhaps back away from the stand. However, they recognised that before reverse thrust was achieved, the propellers would produce forward thrust for a short period; they considered that this strategy had the potential to make the situation worse.

Recorded information

The Flight Data Recorder (FDR) and Cockpit Voice Recorder (CVR) were successfully downloaded. The FDR recording did not include any parameters relating to hydraulics, brakes or ground speed and was therefore of limited benefit to this investigation. The CVR provided

good quality audio of crew communications and the ambient noise.

The recordings showed that 3 minutes and 20 seconds after touchdown, the propeller pitch parameter changed from LOW to NORMAL and the engine torque values and propeller speeds dropped to a recorded value of 0% (propeller speeds are not computed below 25% of the nominal propeller rpm; this also prevents torque values from being calculated). Approximately 35 seconds later, the CVR recorded impact sounds that were consistent with propeller blades striking the stand guidance mirror with an initial propeller speed of 75 rpm. This was followed by a short period without any propeller blade impact and then by rumbles consistent with the propeller blades striking and rubbing the mirror mounting pole. This second set of blade strikes also correlated with small amounts of accelerometer activity recorded on the FDR. During this time, the data showed the fuel flow for both engines reduce to zero at which point no more data was recorded.

Description of the aircraft hydraulic systems

The ATR 72 has two hydraulic systems, Green and Blue, which between them supply services such as landing gear actuation, nosewheel steering, wing flaps, spoilers and the braking system. Each system is pressurised to a nominal 3,000 psi by an AC electric pump, which in turn is powered by a frequency-wild AC generator mounted on each propeller reduction gearbox. A single hydraulic fluid reservoir is used for both systems, with separation provided by means of a partition within the tank. The partition extends to approximately two thirds the height of the tank; a sight glass, together with a fill line, is positioned above the top of the partition. Thus, in the event of a leak, the fluid level will drop below the sight glass to the top of the partition, before continuing to fall on

the Green or Blue side, depending on which system is being depleted.

The Blue system is equipped with an auxiliary DC pump that runs automatically under certain conditions, including when the main system pump pressure falls below 1,500 psi, the landing gear is down and at least one engine is running. The frequency-wild generators drop off line when the propeller rpm falls below 70%. In operational terms, this means that when the propellers' rpm are reduced prior to feathering following the aircraft's arrival on stand, the Green and Blue system AC pumps will cease operating. This will cause the DC pump, powered from starter/generators on the high-speed engine spools, to cut in, thus maintaining pressure in the Blue system. When the engines are shut down the DC pump can operate from a ground electrical supply, or directly from the battery bus via a button on the pedestal.

Each hydraulic system is provided with a 0.2 litre accumulator, which damps out pressure surges and compensates for pump response time in the event of high demand. In addition, there is a 1.2 litre parking/emergency braking accumulator that maintains brake pressure when the aircraft is parked, or, via an emergency brake metering valve, provides brake pressure in the event of failure of the main hydraulic system. Each brake line contains a hydraulic fuse to limit the loss of fluid in the event of a leak downstream. These six fuses are mounted close to the anti-skid manifold in the hydraulic bay, which is located in the lower fuselage aft of the main landing gear.

A schematic diagram of the hydraulic system is shown at Figure 1.

Examination of the aircraft

The aircraft was examined briefly on the evening of the day of the accident, and in detail during daylight on the following day.

It was apparent that the aircraft had moved between 10 and 14 metres beyond the usual stop position area, with a trail of hydraulic fluid under the fuselage that extended a similar distance behind the aircraft, indicating that significant leakage had occurred as the aircraft came to its initial stop. The right hand propeller had struck the first of two poles on which were mounted the stand guidance mirrors. Significant damage had occurred to the propeller blades, which were of composite construction. The impact had caused the mirror to rotate around its pole so that it faced towards the terminal; the aircraft had come to rest with the propeller blades trapped in the gap between the pole and the mirror.

The left main landing gear aft fairing was removed in order to gain access to the hydraulic system components. It was apparent that the floor of the bay was wet with hydraulic fluid and that no fluid was visible in the reservoir sight glass. After removing the filler cap it was found that the Blue system side of the reservoir was empty. The reservoir was refilled; approximately 5 litres were required to achieve the 'Full' indication on the sight glass. The park brake lever was set to off and the DC pump was operated for a few seconds using the pedestal button; this pressurised the Blue system to approximately 3,000 psi, as indicated on the Blue and Emergency Brake accumulator gauges. However, the Blue system pressure decayed rapidly, as fluid was seen to leak from the rearmost of two hydraulic fuse assemblies attached to the anti-skid manifold; the location is shown schematically in Figure 1.

The defective hydraulic fuse was removed and was observed to have a crack in its valve body; this can be seen in Figure 2.

Examination of the hydraulic fuse

The function of a hydraulic fuse is to limit the loss of fluid in the event of a downstream leak, such as could be caused by the failure of a pipe or a union. It operates by means of a flow rate sensing valve mechanism that moves to close off the fluid flow. In the case of the failed component, the crack was effectively upstream of the valve mechanism, which was rendered ineffective as a result.

The valve body bore a data plate that indicated the Part Number was 6279-1, with a serial number of 398. It was date-stamped 15 November 1988 and, in the absence of any records indicating to the contrary, is likely to have been on the aircraft since initial build. This being the case the total hours and flight cycles achieved by the aircraft, and hence the hydraulic fuse, were 30,854 hours and 54,385 cycles, up to the date of the accident. The hydraulic fuses are not 'liferated' items and are maintained 'on condition'.

The component was subjected to a metallurgical examination. The existence of the crack in the valve body, which was manufactured from cast aluminium alloy, was confirmed by means of fluorescent dye penetrant. It was also found that the crack ran along the wall between the two internal chambers within the body. The valve body was subsequently broken open; examination of the fracture surface revealed that it was primarily brittle overload with two small areas of fatigue growth either side of a channel connecting the two chambers, as indicated in the photograph at Figure 3. It was additionally noted that the fracture surface exhibited evidence of shrinkage porosity along its entire length.



Figure 2

Visible crack on surface of valve body

This is a feature that can occur as a result of non-uniform solidification during the casting process. It takes the form of voids within the material, the irregular shapes of which can result in stress concentrations from which fatigue cracks grow. An example of a void is shown in Figure 3.

The fatigue had initiated from multiple origins in the bore of the channel, with initiation appearing to be influenced by the presence of shrinkage porosity. The crack growth extended to a maximum length of around 4.5 mm before the final brittle overload failure occurred; this resulted in the observed crack, which accounted for approximately 50% of the total cross-sectional area of the component along the fracture plane. The brittle nature of the material was such that the critical crack length required before a final overload failure occurred would be relatively short. There was no evidence of any mechanical or corrosion damage that could have influenced the observed failure.

It was not possible to establish when the crack initiated or how quickly it progressed. However, it probably did not reach the surface of the valve body until the final,

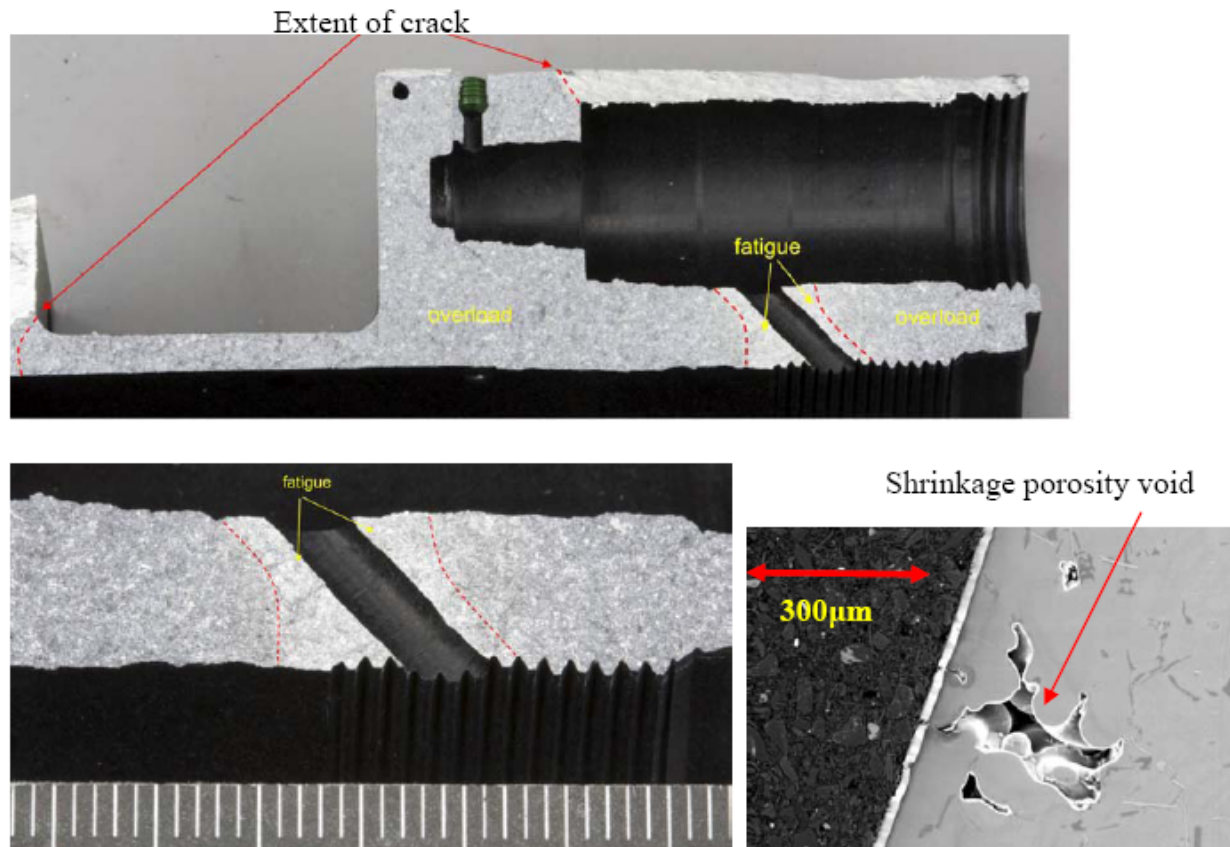

Figure 3

View of sectioned fuse body showing extent of the crack

brittle overload failure, which most probably occurred as the aircraft arrived on stand. Thus, it is unlikely that there would have been any fluid leakage prior to this. In support of this, the technical log contained no record of any top-up of the hydraulic reservoir for three weeks prior to the accident. Information from the operator indicated that one quart of fluid was uplifted on 24 July 2009 and a leaking tee fitting in the left landing gear well was replaced on 29 September 2009. There was no recent maintenance activity on the hydraulic fuses or the immediate area.

Other hydraulic fuse failure events

The aircraft manufacturer stated that the subject event was the third known failure of a hydraulic fuse. The first occurred in Vietnam on 29 March 2007 on an

aircraft that was delivered in 2001 and had achieved 11,500 hours and 12,100 flight cycles. Control of the aircraft was lost on the runway after landing due to the loss of nosewheel steering; the Green hydraulic system was already disabled due to an inoperative pump. The failed fuse, located in the Blue hydraulic line between the parking and emergency brake metering valve (ie the same location as EI-REH), was manufactured in 2000 and is likely to have been fitted to the aircraft since it was built. Although the incident narrative described the fuse as “fractured”, the subsequent investigation of the component was inconclusive. Following this incident the aircraft manufacturer revised the Master Minimum Equipment List (MMEL) to require a check of the hydraulic reservoir contents prior to despatch with one hydraulic pump inoperative.

The second event occurred in Venezuela on 7 October 2009. Details are scarce, but the aircraft reportedly lost “all systems” pressure while taxiing to the runway prior to departure. The aircraft had achieved 28,300 hours and 52,920 cycles, with the inference that the same figures applied to the life of the failed fuse.

Analysis

The investigation showed that the aircraft overran its intended stop position following a failure of a hydraulic fuse in the Blue hydraulic system.

When the brakes failed with the aircraft stationary on the parking stand, the flight crew were presented with a situation beyond their training, and for which the manufacturer had not provided a procedure in the flight crew operating manual. Their actions alerted the cabin crew and emergency services, and by shutting down the engines, they minimised the extent of the damage.

Although required by their procedures, the ground crew did not place chocks under the wheels of the aircraft before attaching the fixed electrical power. The insertion of the chocks may have prevented the aircraft from moving forward, after it had initially come to a halt. This put the ground crew into a hazardous situation as the aircraft began to move forward whilst they were attaching the fixed electrical power.

As a result of this accident the airport operator, several ground handling companies, the CAA, the Health and Safety Executive, and airline representatives, have instigated a series of discussions about ground crew activities around aircraft with engines running. In light

of these discussions, no safety recommendation is made regarding ground handling.

The FDR parameters did not include the operation of the parking/emergency brake lever. The crew had brought the aircraft to a halt before applying the parking brake and feathering the propellers. The last action caused the Green hydraulic system to cease operating, but, by this stage, the Blue hydraulic system would have been supplying the brake pressure. Since no leakage is possible from the failed fuse unless the parking/emergency brake lever is operated, it is probable that the crack in the valve body finally progressed to failure as a result of being exposed to Blue hydraulic system pressure. The crew’s operation of the parking/emergency brake lever resulted in the contents of the Blue hydraulic system accumulator being discharged via the crack. It is possible that, until the contents were exhausted, some braking effect against the decaying propeller thrust was achieved from the residual pressure.

The metallurgical examination revealed that the failure was caused by a fatigue crack in the hydraulic fuse body. Whilst the fatigue crack growth would have been driven by the repetitive pressure cycles, the initiation appeared to be influenced by the presence of shrinkage porosity within the casting. Whilst this might pose a question on the quality of the casting, there have been only two similar events reported across the ATR 42/72 fleet and the fact that one of them occurred to a relatively recently manufactured component suggests a random nature to the failures.

INCIDENT

| | | |
|--|--|-------------------|
| Aircraft Type and Registration: | Boeing 737-300, G-CELI | |
| No & Type of Engines: | 2 CFM 56-3B1 Turbofan engines | |
| Year of Manufacture: | 1986 | |
| Date & Time (UTC): | 19 October 2009 at 1316 hrs | |
| Location: | Manchester Airport | |
| Type of Flight: | Commercial Air Transport (Passenger) | |
| Persons on Board: | Crew - 5 | Passengers - 119 |
| Injuries: | Crew - None | Passengers - None |
| Nature of Damage: | Nil | |
| Commander's Licence: | Air Transport Pilot's Licence | |
| Commander's Age: | 42 years | |
| Commander's Flying Experience: | 5,592 hours (of which 2,565 were on type) Last 90 days - 195 hours Last 28 days - 59 hours | |
| Information Source: | AAIB Field Investigation | |

Synopsis

The flight crew rejected the takeoff after a rapid swing to the right occurred soon after the aircraft reached 80 kt. No technical issues were identified which could have accounted for the swing, but flight recorder data showed it followed a large right rudder pedal input. The flight crew did not recall such an input being made.

Description of the incident

The aircraft departed its stand at Manchester Airport at 1259 hrs for a flight to Budapest. The 1250 hrs ATIS report gave a surface wind as 180°/11 kt, variable between 140° and 210°. Visibility was in excess of 10 km and the temperature was 13°C. The surface was dry.

The aircraft taxied for a full length takeoff from Runway 23 Right. The takeoff mass was 51.4 tonnes, and a flap 5 takeoff was planned. Takeoff speeds had been calculated as: $V_1 = 126$ kt, $V_R = 137$ kt and $V_2 = 144$ kt. A reduced thrust (assumed temperature method) was used.

The co-pilot was handling pilot, and transfer of control from the Commander took place when the aircraft was aligned for takeoff on the runway. ATC reported the wind at the time of takeoff as 200°/7 kt.

Soon after the commander made a routine "EIGHTY KNOTS" call on takeoff, the crew experienced a rapid swing to the right. The co-pilot recalled applying full left rudder pedal, but this was not enough to correct the

swing. The commander took control and took actions to reject the takeoff. The aircraft was approaching the runway edge and a combination of rudder and nosewheel steering was reportedly required to regain the centreline.

The crew brought the aircraft to a stop on the runway and it was attended by the airport fire service. The crew could see no obvious defects that could have accounted for the swing, and after a suitable inspection, the aircraft taxied clear of the runway to a remote stand where the passengers were disembarked.

Both flight crew later described the swing as being unexpected and sudden, and more violent than they had experienced in the simulator when practising engine failure manoeuvres.

Nosewheel steering description

Directional control on the ground is achieved by either nosewheel steering controlled by a steering wheel (tiller) located on the left side of the flightdeck or rudder pedal steering. Movement of the tiller is transmitted via cables to a steering metering valve which directs 3,000 psi of hydraulic pressure to one of the two nosewheel steering actuators to turn the nosewheel as required. A tiller movement of 95° will give 78° of nosewheel rotation. Rudder pedal steering is also available on the ground, when the nose landing gear squat switch is compressed. Any movement of the rudder pedals will be transmitted into directional control of the nosewheel as well as rudder surface movement; the effective gearing is such that full deflection of the pedals produces about 7° of nosewheel movement.

Initial examination

Following the incident it was noted that the steering metering valve was leaking and the valve was replaced. The nosewheel steering and rudder systems were tested in accordance with the maintenance manual and found to be satisfactory. The tyre pressures and wheel braking system were also checked with no faults found. The flap system was inspected for any evidence of asymmetry and none was found.

A maintenance test flight was then performed without incident and the aircraft was returned to service. No further directional control problems have been reported.

Detailed examination of the steering metering valve

The unit was returned to an overhaul agency for investigation. Prior to any strip examination, the unit was tested and the internal leakage was found to be well within limits. After disassembly some minor wear was found on internal components, however, it is thought that this would not have significantly affected the operation of the valve.

Maintenance history

The steering metering valve had been fitted to this aircraft in May 2000. It was removed on 5 December 2007 due to leakage which was found during a routine 'C' Check. The same unit was repaired and reinstalled on G-CELI; at that time the Time Since Overhaul (TSO) was 15,711 hrs and Cycles Since Overhaul (CSO) 12,344. When the unit was removed following the incident the TSO was 20,198 hrs and CSO 14,304.

There was a long history of reported directional control problems on G-CELI. These reports were all difficulties experienced during the landing roll. On 22 May 2008 there was an entry in the aircraft technical log stating that:

'with auto and manual braking left rudder required to keep aircraft straight on landing.'

The brake system was tested and no fault was found. There was a further entry on 27 May 2008 which stated that the aircraft was:

'running almost out of rudder authority on landing with Autobrake 2, brakes released, only really become apparent as speed decays below 70 kts with Autobrake still engaged.'

An Autobrake system test was carried out and no faults found.

There were no relevant reports until 26 April 2009 when there was an entry:

'on landing aircraft gradually swerves to the right as it slows until rudder has inadequate authority and nosewheel steering by the tiller is essential at about 70 kts. Reverse (engine power) symmetrical and no apparent asymmetry in braking, longstanding intermittent problem.'

A rudder pedal steering check was carried out and, on 27 April 2009, a relay in the nose gear steering system was replaced.

On 14 May 2009 the rudder pedal steering was reported as unserviceable:

'on both landings, zero or minimal effect until well into taxi phase. No problem on taxi out or before take-off.'

The nosewheel steering was checked in accordance with the Maintenance Manual and considered serviceable. On 29 May 2009 there was a further report that on

landing, with the aircraft decelerating below 110 kt, full left rudder was required to control the aircraft. Again the aircraft was checked and no faults found. Subsequent pilot reports indicated that there were no further problems until 8 June 2009, when there was a report that the application of full rudder during the landing roll at 20 kt produced 'zero effect' but the nosewheel steering functioned normally once the aircraft vacated the runway. The rudder pedal steering actuator was replaced and there were no further reports of directional control problems.

Flight Recorders

The aircraft was fitted with a 25-hour Flight Data Recorder (FDR) and 2-hour Cockpit Voice Recorder (CVR). These were both removed from the aircraft, downloaded and analysed by the AAIB. Due to the age of the aircraft and relevant regulations at the time of manufacture, the requirements allowed either the rudder control surface or rudder pedal position to be recorded. For G-CELI, rudder control surface position was not recorded. Other parameters of interest to the investigation, but not recorded, were tiller and nosewheel steering.

A time history of salient parameters from the FDR for the incident is shown at Figure 1. The aircraft was configured for a flaps 5 takeoff with the autothrottle engaged (not shown). As soon as the aircraft started to accelerate along the runway (at about 72170 seconds), increasing amounts of right rudder pedal were required to maintain the runway heading (evidenced by the zero lateral acceleration). At approximately 72185 seconds and 83 kt computed airspeed, the rudder pedal deflected further to the right, reaching full travel one second later. A maximum lateral acceleration to the right of 0.3 g was reached about two seconds later at which point the crew, aware of a problem, rejected the takeoff. A heading change of approximately 10° to the right was

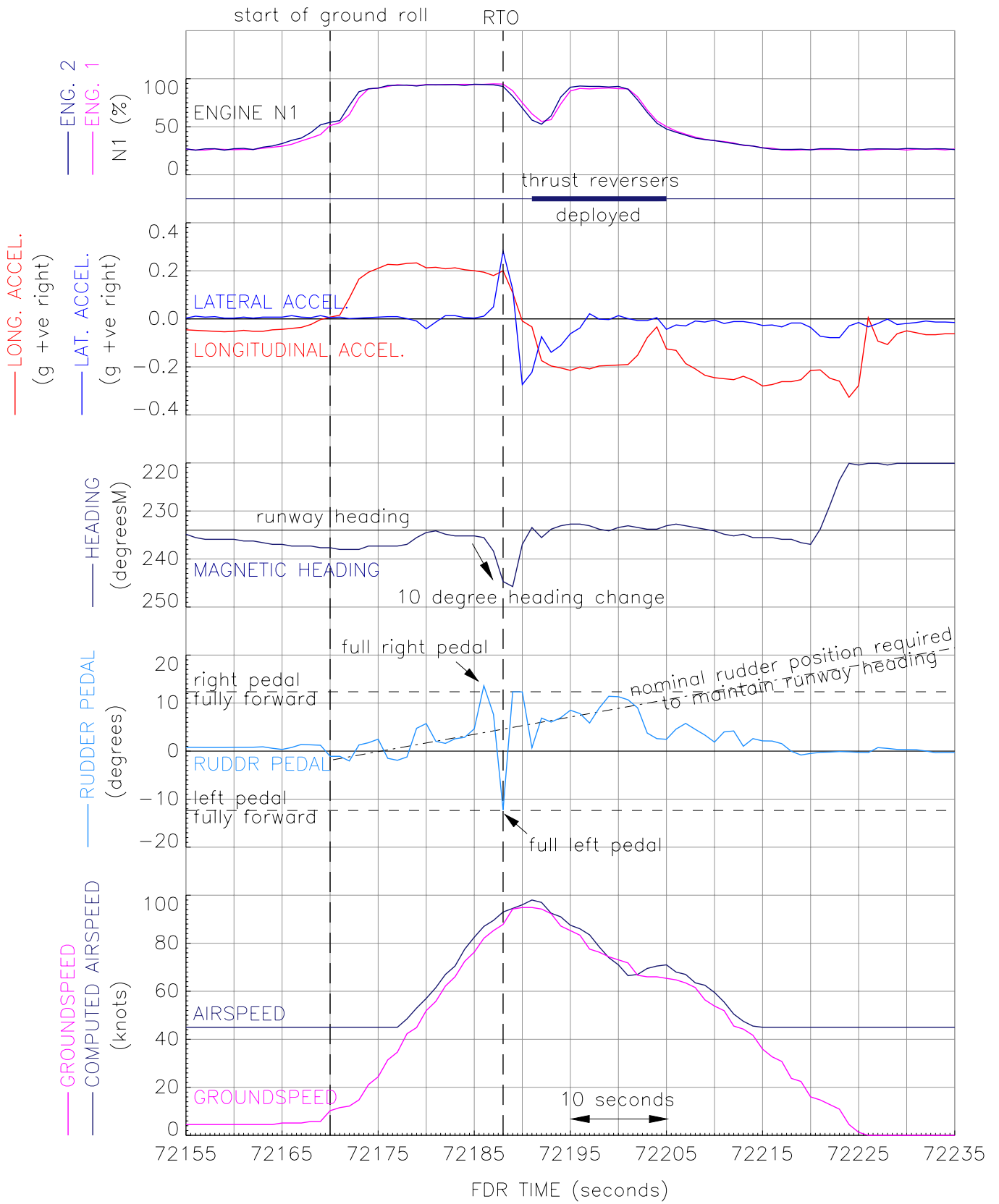

Figure 1
Salient FDR parameters for the incident to G-CELI

also recorded at this time. Subsequently, a large left rudder pedal input to just under full travel was recorded followed by a maximum lateral acceleration to the left of 0.3 g and a return of the aircraft back to the runway heading. Again, increasing amounts of right rudder pedal were required to maintain runway heading during the deceleration.

Simulation

The aircraft manufacturer performed a 'desktop' simulation which used the FDR data in conjunction with a mathematical model of the aircraft to calculate the aircraft behaviour. They reported that,

'for this analysis, the desktop simulation was used to determine if the excursions in the heading and lateral acceleration data were a result of the rudder pedal input. The simulation rudder pedal deflection was driven with the FDR rudder pedal deflection plus a small bias. The simulation winds were set to a constant value of 7 knots from a direction of 200 degrees (tower reported winds). The data show a reasonable match with heading and lateral acceleration. These results support the observation that the heading change to the right was the result of the rudder pedal input to the right.'

Conclusion

The flight crew did not recall any significant rudder pedal input before the swing occurred, although the flight data showed this did occur. The simulation showed that the aircraft's behaviour was consistent with the observed rudder pedal input and confirmed that there was no other directional control input. The recorded heading data showed no change prior to the rudder pedal input which would be expected had there been a nosewheel steering input. This aircraft has a long history of directional control problems on the ground; however, these reports all occurred during the landing roll and not during takeoff. The steering valve was found to be leaking, but this was unlikely to have affected its operation.

INCIDENT

| | | |
|--|--|------------------------|
| Aircraft Type and Registration: | Boeing 737-800, EI-DLJ | |
| No & Type of Engines: | 2 CFM 56-7B26 turbofan engines | |
| Year of Manufacture: | 2005 | |
| Date & Time (UTC): | 17 July 2009 at 1225 hrs | |
| Location: | London Stansted Airport, Essex | |
| Type of Flight: | Commercial Air Transport (Passenger) | |
| Persons on Board: | Crew - 6 | Passengers - 164 |
| Injuries: | Crew - None | Passengers - 1 (Minor) |
| Nature of Damage: | None | |
| Commander's Licence: | Airline Transport Pilot's Licence | |
| Commander's Age: | 40 years | |
| Commander's Flying Experience: | 8,500 hours (of which 4,755 were on type) Last 90 days - 259 hours Last 28 days - 91 hours | |
| Information Source: | AAIB Field Investigation | |

Synopsis

Whilst boarding the aircraft using the forward airstairs, a small child fell through the gap between the handrail and the top platform, on to the ground. The child was airlifted to hospital for further treatment and was released 24 hours later. Three Safety Recommendations have been made as a result of this investigation.

Boeing 737 forward airstairs description

Some Boeing 737 series aircraft are fitted with a set of retractable airstairs at the forward left cabin door, to allow the boarding and disembarkation of passengers without the need for additional ground support equipment. These airstairs include an integral two-rung handrail on either side. These rise into position during deployment of the stairs, but due to the geometric

restrictions imposed by the retraction mechanism design, they do not extend to the fuselage side. In order to bridge the gap between the top of the handrails and the fuselage, a manually extendable handrail is fitted to each of the integral rails. After deployment of the airstairs, these are extended and secured to points in the entry door frame, Figure 1. Each extendable rail is supported by a strut extending from the side rail of the airstairs.

History of the incident

The child, aged three years at the time of the incident, was accompanied to the aircraft by her mother, who was carrying a younger sibling together with a carry-on bag. They had opted for priority boarding and were

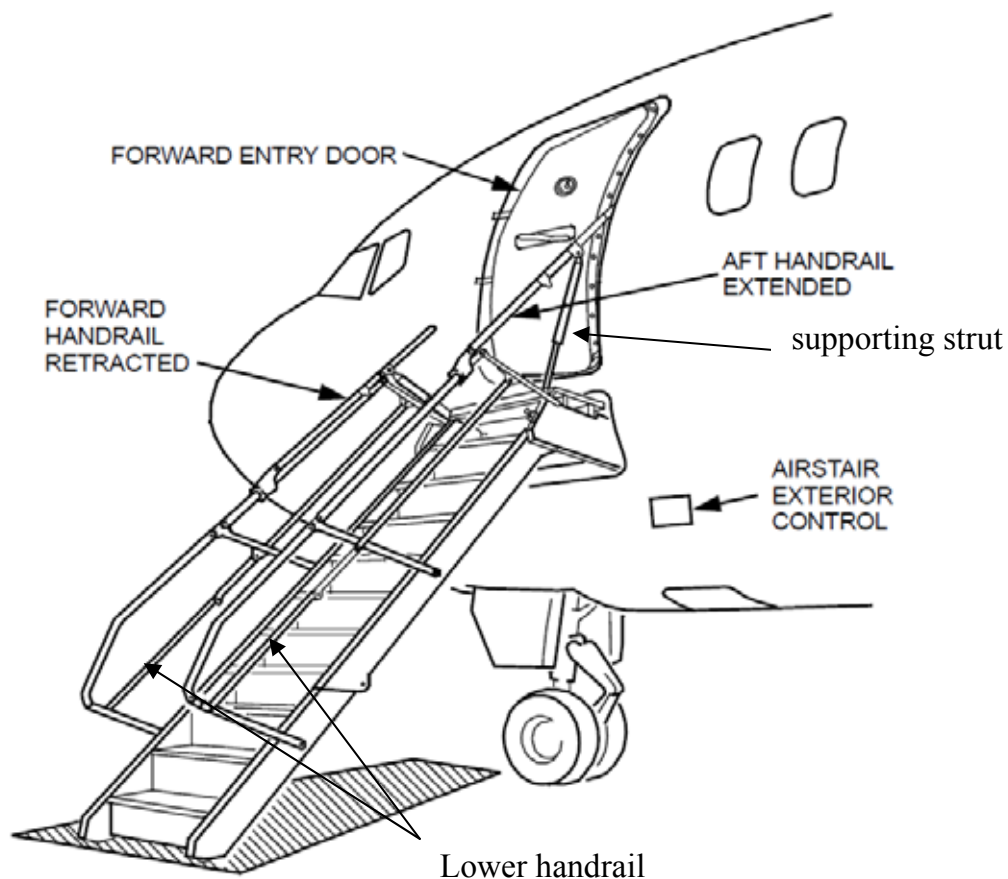

Figure 1

Boeing 737 forward airstairs
(Published with the permission of Boeing)

embarking via the aircraft's forward integral airstairs. The child, accompanied by her mother and sibling, climbed the airstairs with other passengers. Due to her mother's lack of a free hand, the child climbed the airstairs unassisted, but she held onto the lower handrail. When she reached the top of the stairs, she turned towards her mother, leaned backwards and fell through the gap between the extendable handrail and the top of the airstairs, onto the hardstanding below. After receiving initial medical assistance on site, the child was airlifted to hospital where she received additional treatment for her injuries, she was released from hospital 24 hours later.

Previous events and safety actions

As a result of four previously reported similar incidents involving small children, the FAA published a Special Airworthiness Information Bulletin (SAIB) NM-07-47 in September 2007. This was distributed to all current Boeing 737 operators and recommended that owners and operators of the Boeing 737 series of airplanes incorporate Boeing Service Bulletin (SB) 737-52-1157 and Monogram Systems (manufacturer of the airstairs) SB 870700-52-2130. These bulletins required warning placards to be added to the risers of the airstairs steps and the aircraft door apertures, together with the addition of anti-skid material to the top platform and the side rails. The SAIB also highlighted the fact that

Boeing had revised the Flight Attendant Manual for the 737 series of aircraft, to include a warning regarding the need for operators to pay particular attention to passengers boarding with small children or with special needs.

Page 7.10.34 of the revised Boeing Flight Attendant Manual (29 October 2008) states:

'WARNING: As passengers are boarding or deplaning, pay particular attention to persons with small children or those with special needs. Small children on airstairs should be attended by an adult or responsible person.'

This manual is provided to operators on delivery of an aircraft and is intended to provide a guide to assist in the development of a Cabin Crew / Safety Equipment and Procedures (SEP) manual to satisfy regulatory requirements. In the event that the manual is amended, there is no revision service to ensure that current operators of the type receive the amended information. The Flight Attendant Manual received by the operator with its first Boeing 737-800 was issued on 28 September 1998.

Investigation

The Boeing 737 series of aircraft is one of a number of types that use integral airstairs to facilitate boarding and disembarkation without relying on the presence of ground based steps or an airbridge. When deployed, the left and right extendable handrails are intended to provide protection against people falling sideways off the upper section of the airstairs. Whilst these handrails appear to provide adequate protection for adults, a gap exists between the handrail and the airstairs platform which is large enough to allow a small child to pass through it and fall onto the hardstanding below. At the

time of the accident, the airstairs installed on EI-DLJ had the warning placards on the risers and anti-slip material installed in accordance with Monogram Systems SB 870700-52-2130, but the door aperture placards, detailed in Boeing SB 737-52-1157, had not yet been applied.

As part of the investigation, the boarding and disembarkation process used by various operators of the Boeing 737, when using the forward airstairs, was observed. It was noted that in 95% of cases, during disembarkation, passengers travelling with several small children and hand baggage received no assistance from either cabin crew or ground staff. However, ground and cabin crew provided assistance in 78 % of cases when single passengers accompanied by small children were allowed to pre-board the aircraft. The operator does allow pre-boarding of passengers if they opt for priority boarding; however, in this incident, although the passenger accompanied by her small child had opted for priority boarding, neither the cabin crew nor ground crew gave them assistance during boarding.

It was observed that when portable ground based steps, or the aircraft's integral airstairs were used, an adult boarding or disembarking with 'carry-on' baggage, which could not easily be placed over the shoulder, and a small child, found themselves, in certain situations, in a position where neither hand was available to provide support during the ascent or descent. This situation was further complicated when an adult was accompanied by more than one small child and 'carry-on' baggage, as some of the children had to negotiate the steps with little assistance from the adult.

Boarding and disembarking procedures

The procedures laid down in the operator's SEP manual require that three of the four cabin crew members

remain in position by the forward and rear doors, and near over-wing exits, for the duration of boarding. The fourth cabin crew member would normally be providing passenger assistance or completing other duties within the cabin. However, during boarding, the ability of the cabin crew member at the forward doors to identify those passengers requiring assistance, whilst they are ascending or descending the airstairs, is limited.

Section 2.4.13.5 of the operator's SEP manual regarding passenger disembarkation states:

'Passengers accompanying young children should be instructed to hold their hands when descending the stairs and on the ramp.'

Immediate safety action taken by the operator

After this incident, the operator initiated a review of the measures that could be taken to minimise the possibility of a similar event recurring. As a result, the operator raised a modification which introduces a roller-tensioned, high-visibility tape between the door aperture and the extendable handrail strut. After approval by the relevant airworthiness authorities, this modification will be embodied on the operator's fleet as a matter of priority.

Safety Recommendations

The lack of an amendment service for the Boeing 737 Flight Attendant Manual means that current operators of the type do not receive updates to the manual. It is understood that this situation applies to all of the Boeing commercial aircraft product line. In this case, the warning regarding the provision of assistance to passengers boarding with small children and those with special needs, had not been passed to the operator from the manufacturer; however, the operator would have been aware that some changes had been made

to the manual upon receipt of FAA SAIB NM-07-47. The following Safety Recommendations are therefore made:

Safety Recommendation 2010-017

It is recommended that Boeing establish a process to inform the operators of all Boeing commercial aircraft of changes to the relevant Flight Attendants Manual.

Safety Recommendation 2010-018

It is recommended that Ryanair review their current passenger boarding and disembarking procedures so that assistance is made available to passengers accompanied by children, and those with special needs.

The gap between the extendable handrail and the upper platform of the Boeing 737 airstairs, represents a hazard to small children boarding or disembarking the aircraft. Four previous events resulted in the publication of FAA SAIB NM-07-47 in September 2007, the amendment of the Boeing 737 Flight Attendant Manual and the release of two SBs. Whilst these SBs provide increased protection against slipping on the airstairs upper platform, and visual cues to a potential personal injury risk, they do not provide physical protection against a child falling through the gap. The modification proposed by the operator provides a significant visual cue to the lack of a rigid barrier in this area, but provides only a limited physical protection against falling. Therefore, the following Safety Recommendation is made:

Safety Recommendation 2010-019

It is recommended that Boeing review the design of the Boeing 737 forward airstairs with the intention of adding a removable barrier to minimise the possibility of a child falling through the gap between the extendable handrail and its upper platform.

INCIDENT

| | |
|--|--|
| Aircraft Type and Registration: | DHC-8-402 Dash 8, G-JEDI |
| No & Type of Engines: | 2 Pratt & Whitney Canada PW150A turboprop engines |
| Year of Manufacture: | 2001 |
| Date & Time (UTC): | 21 December 2009 at 1052 hrs |
| Location: | London Gatwick Airport |
| Type of Flight: | Commercial Air Transport (Passenger) |
| Persons on Board: | Crew - 4 Passengers - 72 |
| Injuries: | Crew - None Passengers - None |
| Nature of Damage: | Damage to a wiring loom, and structure, in the left centre-wing section |
| Commander's Licence: | Air Transport Pilot's Licence |
| Commander's Age: | 33 years |
| Commander's Flying Experience: | 4,241 hours (of which 2,677 were on type) Last 90 days - 108 hours Last 28 days - 35 hours |
| Information Source: | AAIB Field Investigation |

Synopsis

During departure from London Gatwick Airport, the aircraft suffered a failure of its AC electrical system. A PAN was declared and the aircraft returned to Gatwick for an uneventful landing. Examination revealed wiring damage in the trailing edge area of the left centre wing that was due to chafing from the head of a blind rivet in a loom support bracket. The aircraft manufacturer has since issued a modification to replace the blind rivets with solid rivets and to inspect the wiring for damage.

History of the flight

The aircraft departed London Gatwick Airport on a scheduled passenger flight to Düsseldorf. As it climbed through 6,000 ft the following caution lights illuminated

almost simultaneously on the caution and warning annunciator panel:

L AC BUS, R AC BUS, L TRU, R TRU, #1 AC GEN,
#2 AC GEN

along with a series of associated system failure captions.

The commander judged that the L and R AC BUS cautions had illuminated first. As the aircraft continued to climb towards its cleared level of FL120 the pilots requested descent to avoid icing conditions. ATC cleared the aircraft to descend to FL110 but, because it remained in icing conditions with limited icing protection available,

the pilots made a “PAN PAN” (urgency) transmission and requested further descent and diversion to Gatwick. The aircraft exited icing conditions at approximately FL100 in the subsequent descent.

The commander, as pilot monitoring, handed responsibility for radio communications to the co-pilot and began conducting procedures listed in the Emergency Check List (ECL), in the following order:

LOSS OF BOTH AC GENERATORS
(WITH PROP DE-ICE ON)
AC GEN CAUTION
TRU CAUTION

The commander briefed the senior cabin crew member after completing the ECL procedures and informed the passengers of the intention to return to Gatwick. Although the airframe appeared clear of ice the pilots elected, as a precaution, to conduct the approach using FLAP 35 at increased speed in accordance with company procedures for flight in icing conditions. The landing was uneventful and the aerodrome fire and rescue service that attended was not required to assist.

Engineering activity

The engineers at London Gatwick began to troubleshoot the reported problems with the AC electrical system by carrying out a ground run of both engines to assess the engine AC generator serviceability. Prior to this, the Electrical Power Control Unit (EPCU) had recorded in its memory a fault with the right AC generator. When the engineer selected the right generator to ON, he heard a loud mechanical ‘clunk’ noise and after this neither the left nor the right generator could be brought online. The Left and Right Generator Control Units were exchanged with each other; the EPCU registered a fault code that related to a fault with the left AC generator. The engineers decided to exchange the left and right AC

generators, however, on removal of the left AC generator they discovered that its input drive shaft had sheared.

The right AC generator was then slaved into the left engine and an engine run carried out on the left engine only. Again, as the engineer selected the left generator to ON, there was a repeat of the loud mechanical ‘clunk’. On inspection of the generator, they discovered that its input shaft had also sheared.

The engineers then carried out wiring checks and discovered that there had been significant damage to the wiring loom that runs within the trailing edge area of the left centre wing section.

Flight recorders

The two flight recorders were removed from the aircraft and replayed. The two-hour CVR had continued to run during the extensive maintenance activity after the flight and so had recorded over the airborne event and subsequent landing. The FDR had retained the recording from the incident flight and subsequent fault-finding work.

The takeoff and initial climb were uneventful. However, as the aircraft climbed through 5,900 ft, the standby hydraulic system pressure was recorded as reducing from 3,000 psi to about 100 psi over a period of about four seconds. As this pressure reduced, the status of the left and right AC generators and also both left and right AC buses changed to indicate that they were offline. These changes were accompanied by a Master Caution.

The aircraft briefly levelled off at 6,500 ft before the climb was recommenced. A maximum altitude of FL130 was achieved before starting to descend. Just prior to levelling off at FL80 the aircraft commenced a 150° right turn. Once established on a heading of 250°M the left

AC bus and left generator were recorded as coming back online. This was followed, 10 seconds later, by the right AC bus and generator.

The aircraft commenced its final descent and, whilst passing through 4,100 ft, again the status of both AC buses and both generators changed to indicate that they were offline. At the same time, the recorded values of standby hydraulic pressure briefly reduced to zero before returning to a steady-state indication of 92 psi. The landing and subsequent taxi were uneventful. Both AC buses indicated offline as the engines were shut down.

The remainder of the FDR recording confirmed the subsequent maintenance activity that had taken place.

Electrical system description and operation (Figure 1)

The Dash 8 electrical system is predominantly DC, however certain systems such as de-icing heaters, fuel auxiliary pumps and the standby power unit (SPU) hydraulic pump are powered from a frequency-wild 115 V AC electrical system. Each engine drives an AC generator which in turn supplies its respective AC Bus. Each generator is controlled by its own Generator

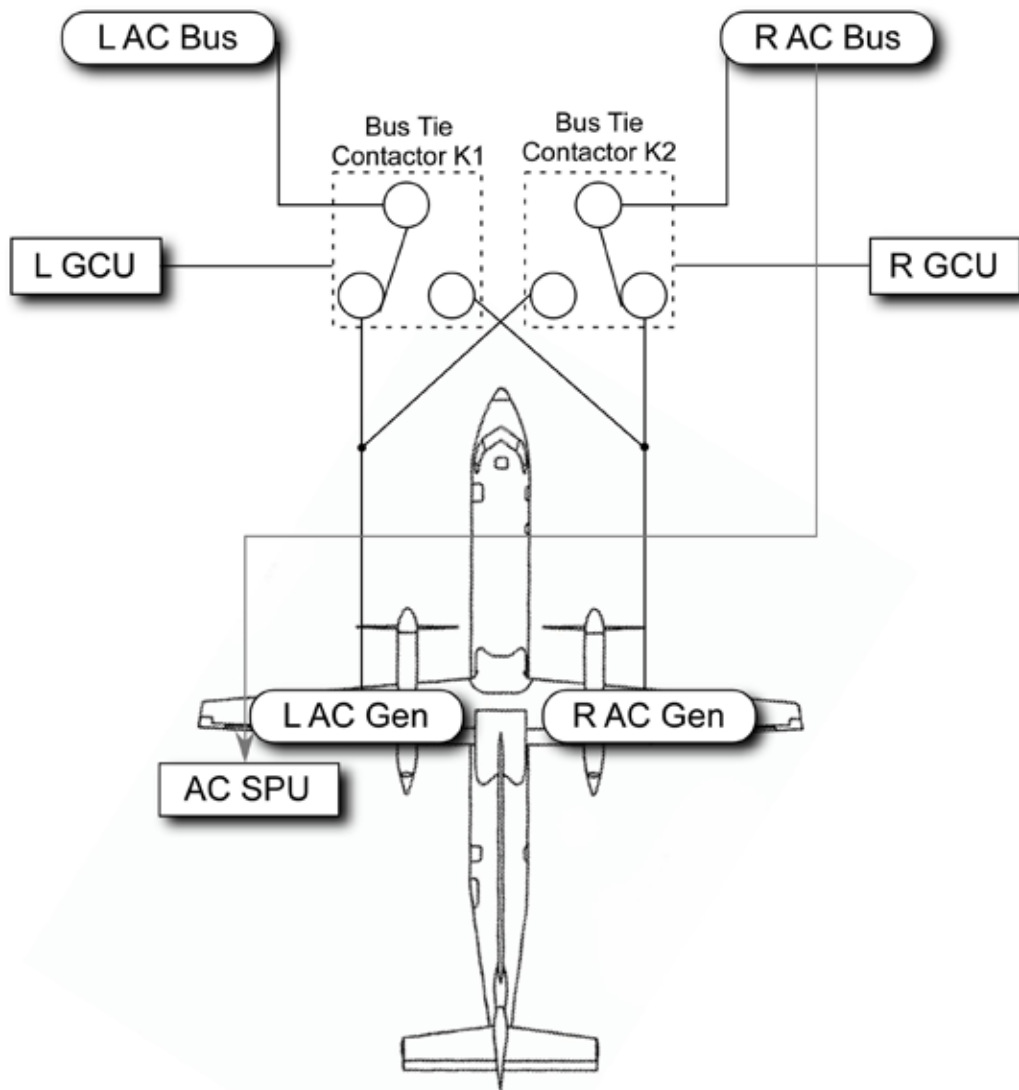

Figure 1
AC Electrical System

Control Unit (GCU). The Electrical Power Control Unit (EPCU) receives voltage and current information and uses this for output to the cockpit display; it also stores the last fault condition in its memory.

In the event of a fault with a generator, the related GCU will isolate the generator and illuminate the related ‘#1 AC GEN’ or ‘#2 AC GEN’ caution light on the cockpit warning panel. Contactors (K1 and K2) provide a means of powering an AC Bus from the opposite engine. In the event of a generator failure, the related contactor automatically connects the affected AC Bus to the serviceable generator. If the AC Bus is not powered, the ‘L AC BUS’ or ‘R AC BUS’ cautions lights are illuminated on the cockpit warning panel. The FDR records the status of the cockpit warning lights as an indication of the status of the AC Gen and the AC Buses.

The failure of the both the left and right AC Buses results in the loss of electrical power to the anti-ice heaters fitted to the pitot probes, the propellers and the engines. This results in the illumination of the associated caution lights on the cockpit panel. The majority of the remaining aircraft systems are powered by the DC electrical system and therefore remain functional.

On the ground, the two AC electrical buses can be supplied with external power when this is connected to the aircraft.

Aircraft examination

A wiring loom routed in the left centre-wing section had sustained extensive fire and overheat damage and was localised to an area where the loom was supported by the use of plastic tie straps attached to a support bracket riveted to the lower wing skin. The plastic tie strap and protective fibreglass tape, used to protect the loom from damage from the tie strap, were no longer attached to

the loom and the plastic support bracket had melted (Figure 2).

There was evidence of arcing between the wires within the loom, as well as between the wiring and the aircraft structure close to the loom support bracket. Arcing had also taken place between the wiring and the head of the cadmium-plated blind rivet that attached the loom support bracket to the structure (Figure 3).

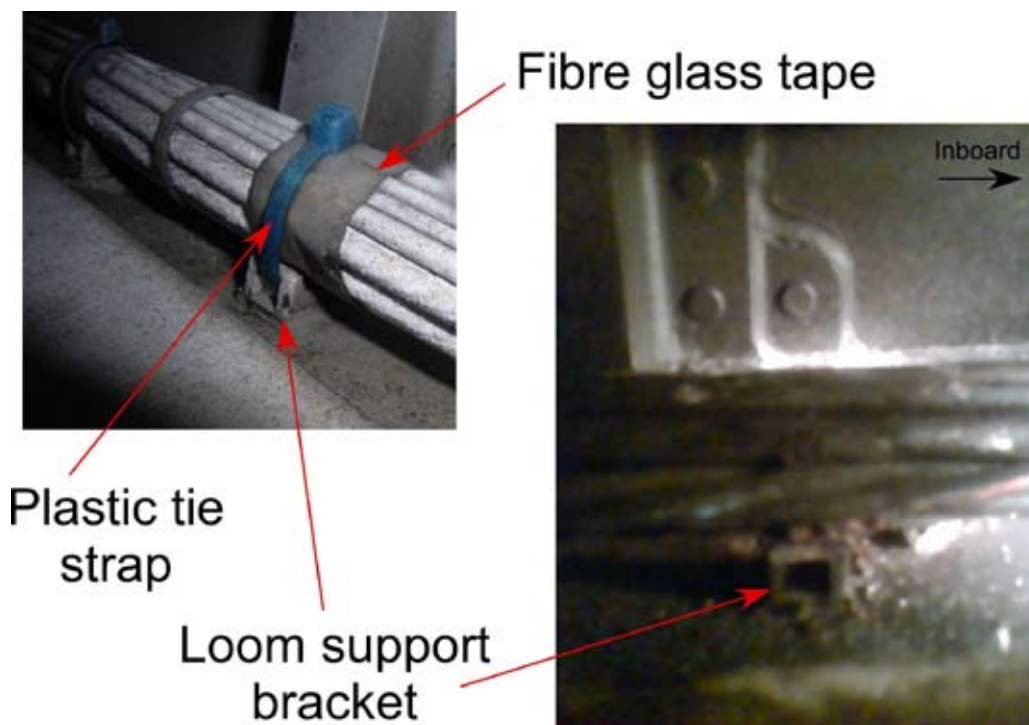

Figure 2

Loom support bracket

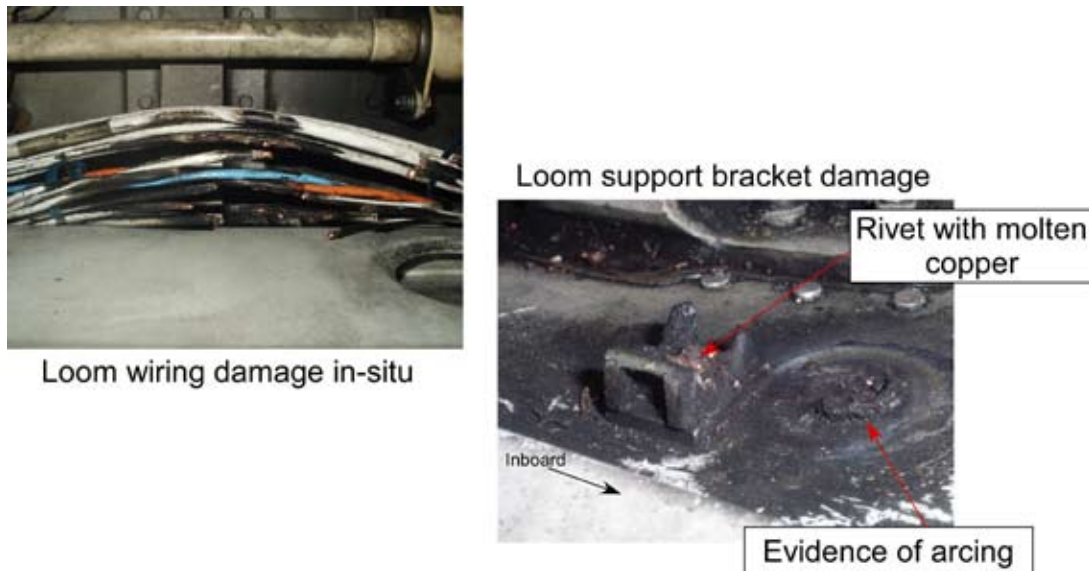

Figure 3

Wiring damage and evidence of arcing

The wiring loom and the remains of the tie straps, fibreglass tape and the loom support bracket were sent to a forensic laboratory for a detailed examination. The loom contained 22 wires, some of which had fused due to the arcing and fire, this had resulted in the loss of most of the evidence of the original mode of failure. The wires were analysed using various methods of microscopy, which showed that they had signs of localised mechanical damage, with one wire showing abrasion with a sharp object. Later examination of the abrasions on the wire showed them to contain particles of cadmium and iron.

Analysis of the remains of the tie straps and protective fibreglass tape recovered from the aircraft were also analysed. These had suffered from the effects of the fire. However, one of the tie straps had a notch which appeared to be due to mechanical damage and heat, and contained a considerable number of cadmium particles.

The affected wiring loom contained wires providing power from:

- The left AC bus to the left propeller de-icing system
- The right AC generator power feed to the contactor K1 in the left engine nacelle
- The left AC generator electrical power feed to the contactor K2 in the right engine nacelle
- The right AC bus to the standby power unit (SPU) in the left engine nacelle
- The left AC bus to the volt sense input to the EPCU
- The external power bus to contactor K1 in the left engine nacelle

The manufacturer examined and tested the AC generators removed from G-JEDI and, apart from the fractured spline shafts, they were found to be serviceable. Also, contactors K1 and K2 were removed and tested and were also found to be serviceable.

Analysis

Engineering issues

The examination of the wiring loom indicated that the failure resulted from chafing by the head of the blind rivet that secures the loom support bracket to the aircraft structure. The action of inserting a blind rivet causes a shear lip on the inner stem. The loom sits upon the loom support bracket and the tie wrap is inserted around the loom and over the head of the rivet and its stem. Over time the relative movement of the wiring loom to the fixed support bracket caused localised chafing, firstly, of the tie strap and then of the wiring loom itself. The stem of the rivet is cadmium plated and particles of cadmium were found in the tie strap and wiring recovered from the area of the fire. There are no other items in the affected area that are cadmium plated and therefore the particles can only have come from the blind rivet stem.

The chafing reached an extent where the insulation of one of the wires was compromised and a short, with associated arcing, occurred between the wire and rivet stem, which would have had a ground potential. This arcing would have led to localised heating and damage to the other wire's insulation and eventual arcing between wires as well as the structure.

The first indication that the chafing had reached the extent that shorting was taking place was the indication to the flight crew of the failures of the AC electrical system. It is likely that the GCU detected over current

due to shorting in the left generator supply. The GCU would then have automatically switched over contactor K1 so that the Right AC generator was supplying the Left AC bus. However, the affected wiring loom also contained wiring that was supplied from the left AC bus, and this therefore led to faults being detected by the right GCU and the subsequent shutting down of the Right AC generator. With both generators now deactivated, there was no longer an AC supply to the left and right AC Buses and the systems supplied by them would also have failed as a result of the loss of power.

It is likely that the left generator drive shaft was still attached during and following the flight. However, when the engineers powered up the AC electrical system on the ground, high currents within the system, from the potential paralleling of the frequency wild generators due to the wiring loom damage, would have caused the generator to electro-magnetically lock and the drive shaft to shear as designed.

Safety action

Based on the findings of this investigation the aircraft manufacturer issued a modification for operators to replace the blind rivets on the loom support bracket with solid rivets, and to inspect the wiring for damage. Transport Canada has since issued Airworthiness Directive CF-2010-08 which mandates the rivet replacement and wiring inspections.

ACCIDENT

| | | |
|--|--|-------------------|
| Aircraft Type and Registration: | Cessna 152, G-FIFO | |
| No & Type of Engines: | 1 Lycoming O-235-L2C piston engine | |
| Year of Manufacture: | 1981 | |
| Date & Time (UTC): | 4 June 2010 at 1432 hrs | |
| Location: | Popham Airfield, Hampshire | |
| Type of Flight: | Private | |
| Persons on Board: | Crew - 1 | Passengers - None |
| Injuries: | Crew - 1 (Minor) | Passengers - N/A |
| Nature of Damage: | Damage to nose landing gear, fuselage, wingtips and tail | |
| Commander's Licence: | Private Pilot's Licence | |
| Commander's Age: | 53 years | |
| Commander's Flying Experience: | 125 hours (of which 80 were on type) Last 90 days - 9 hours Last 28 days - 6 hours | |
| Information Source: | Aircraft Accident Report Form submitted by the pilot | |

Synopsis

The pilot made a normal approach in light and variable wind conditions. He reported that, just prior to landing, the aircraft experienced a tailwind component and touched down in a flat attitude. The nose landing gear was damaged and, following an abandoned go-around, the aircraft entered some long grass and pitched over onto its back.

History of the flight

The pilot had flown from Popham Airfield to Chichester (Goodwood) Airfield before returning to Popham. The weather for the flight was good, with the wind light and variable and cloud and visibility OK. On returning to Popham, he carried out an overhead rejoin for a left-hand

circuit to Runway 08. On the downwind leg 10° of flap was selected, with a further 10° on the base leg. The aircraft was established on the final approach with landing flap lowered and an approach speed of 65 kt IAS, with the winds given as light and variable. The approach was normal but just prior to landing, the pilot detected a tailwind component and the aircraft touched down in a flat attitude, accompanied by a loud bang that was heard and felt by the pilot.

He commenced a go-around but realised that the nosewheel steering was not functioning properly, as he was unable to maintain normal directional control. The pilot closed the throttle and, with the speed reducing,

decided to enter the long grass to his right. This was in order to avoid the buildings and parked aircraft to his left. The pilot reported that, before the aircraft had stopped, the long grass caused it to pitch over onto its back. He isolated the electrical and fuel systems and vacated the aircraft through the normal exit. The airfield Rescue and Fire Fighting Service attended the scene but there was no fire. The pilot sustained minor injuries.

Conclusion

The pilot concluded that the cause of the accident was being caught by an unexpected tailwind component just prior to landing. This resulted in damage to the nose landing gear causing him reduced directional control. Additional damage resulted from the effects of the long grass.

ACCIDENT

| | | |
|--|---|-------------------|
| Aircraft Type and Registration: | Cessna 172S Skyhawk, G-SOOA | |
| No & Type of Engines: | 1 Lycoming IO-360-L2A piston engine | |
| Year of Manufacture: | 2009 | |
| Date & Time (UTC): | 18 May 2010 at 1330 hrs | |
| Location: | Chichester (Goodwood) Aerodrome, West Sussex | |
| Type of Flight: | Private | |
| Persons on Board: | Crew - 1 | Passengers - None |
| Injuries: | Crew - None | Passengers - N/A |
| Nature of Damage: | Nose gear oleo broken, propeller tips scuffed, front spat split, engine shock-loaded, possible damage to firewall | |
| Commander's Licence: | Private Pilot's Licence | |
| Commander's Age: | 64 years | |
| Commander's Flying Experience: | 155 hours (of which 10 were on type) Last 90 days - 11 hours Last 28 days - 5 hours | |
| Information Source: | Aircraft Accident Report Form submitted by the pilot and UK CAA ATS occurrence report | |

The solo recreational flight was returning to Chichester for a landing on Runway 24. The wind was reported as 210° and varying between 15 and 20 kt. Approaching the airfield perimeter on final approach, the instruments indicated a reduction in airspeed so power was applied. This resulted in an airspeed increase to approximately 85 kt. The aircraft passed the threshold at a reported height of 200 ft. The pilot reduced power and pitched the aircraft up to reduce speed. The rate of descent increased. He flared the aircraft at an airspeed of approximately 75 kt and was seen to touch down beyond the intersection with Runway 14/32. The aircraft was observed to bounce three times, the final time achieving an estimated 45° pitch-up attitude before pitching nose-down and

landing heavily on the nosewheel. It came to a halt near to the end of the runway.

The pilot taxied the aircraft off the runway and towards the tower. ATC reported that the nose oleo had suffered damage and advised the pilot to stop and shut down. Debris from the front spat was subsequently removed from the runway. Later inspection revealed that the nose gear oleo, propeller tips and front spat had been damaged and that the engine may have been shock-loaded and the firewall damaged.

The UK AIP for Chichester contains the warning:

'Pilots may experience windshear on runways 06 and 24 particularly in strong wind conditions.'

The pilot assessed that causal factors included being too high during the final approach, being faster than planned on touchdown and being too far down the runway to permit a safe go-around for the given obstacles at the end of the runway. He stated that he should have aborted the landing at 200 ft and gone around.

ACCIDENT

| | | |
|--|--|-------------------|
| Aircraft Type and Registration: | Cessna F177RG Cardinal RG, G-BFPZ | |
| No & Type of Engines: | 1 Lycoming IO-360-A1B6D piston engine | |
| Year of Manufacture: | 1973 | |
| Date & Time (UTC): | 29 March 2009 at 1610 hrs | |
| Location: | Popham Airfield, Hampshire | |
| Type of Flight: | Private | |
| Persons on Board: | Crew - 1 | Passengers - None |
| Injuries: | Crew - None | Passengers - N/A |
| Nature of Damage: | Damage to rear fuselage skin, stringers, stabilator tips and reinforcing strips | |
| Commander's Licence: | Private Pilot's Licence | |
| Commander's Age: | 49 years | |
| Commander's Flying Experience: | 294 hours (of which 4 were on type) Last 90 days - 5 hours Last 28 days - 1 hour | |
| Information Source: | AAIB Field Investigation | |

Synopsis

The pilot selected the gear for landing, observed that the single DOWN AND LOCKED light illuminated and visually checked that the landing gear was extended. On touchdown, the main landing gear folded rearwards and the aircraft came to rest with the nose landing gear extended. The green DOWN AND LOCKED light remained illuminated. An engineering examination found that both main landing gear DOWN AND LOCKED magnetic proximity switches were 'stuck' in their DOWN AND LOCKED positions due to a lack of lubrication and weak return springs. Two Safety Recommendations are made.

History of the flight

The pilot made an overhead join for a right-hand circuit

to land on Runway 26, at Popham. On the downwind leg of the circuit he lowered the landing gear and observed that the green DOWN AND LOCKED light was illuminated. He also made a visual check that the landing gear was extended by using a mirror that was mounted under the starboard wing. He was able to see the nose and starboard landing gear, and both appeared to be extended. After turning onto the final approach the pilot again checked that the green DOWN AND LOCKED light was illuminated and made an RT call "Final two six three greens" (in fact this aircraft is fitted with only one green light). The touchdown was gentle and on the main landing gears but as the aircraft's weight settled onto the landing gear it retracted rearwards.

The aircraft came to a halt on the runway, with its weight on the extended nose landing gear and the rear of the fuselage, the green DOWN AND LOCKED light was still illuminated. Following a successful evacuation the pilot returned to the aircraft and, after assuring himself that it was safe to turn on the electrical system, photographed the cockpit which showed the green DOWN AND LOCKED light illuminated. This was later confirmed by the airfield staff who recovered the aircraft.

Description of landing gear and downlock operation

Retraction and extension of the landing gear is accomplished by a hydraulic system integrated with electrical control and indication circuits. There is one hydraulic actuator for the nose landing gear and one that drives a gear system for both main landing gears and hydraulic fluid is supplied to the actuators by an electrically-powered reversible pump. The power to the electrical pump is controlled by the landing gear selector mounted in the cockpit instrument panel, a pressure switch and the three downlock proximity switches. As the landing gear selector is moved to either the UP or DOWN position, the pump directs hydraulic fluid through a power pack control valve assembly to the landing gear actuators. Mechanical over-centre locks provide up and down locks for the nose landing gear and the main landing gears utilise hydraulic pressure for positive up-lock and hydro-mechanical downlocks.

Mounted in the instrument panel are two landing gear position indicator lights. A single amber light illuminates when the landing gear is UP AND LOCKED; a single green light illuminates when it is DOWN AND LOCKED. Each of the three landing gears has a downlock proximity switch and all three proximity switches have to be 'made' to complete the electrical circuit to illuminate the green DOWN AND LOCKED light in the cockpit. In addition to

illuminating the green indicator light, the making of all three downlock proximity switches opens the electrical circuit to the hydraulic pump which switches it OFF. When the hydraulic pump switches off, the pressure in the down lines slowly dissipates over a period of time which is dependant upon the seal leak rates in the landing gear actuators. The hydraulic pump will switch ON when any of the downlock proximity switches open, providing the landing gear selector is to the DOWN position. When a correctly adjusted landing gear is in the DOWN AND LOCKED position no hydraulic pressure is required to maintain it in that condition. When the landing gear selector is moved into the UP position the electrical power is fed directly to the hydraulic pump, not via the downlock proximity switches.

The main landing gear downlock proximity switches consist of a fixed 'reed' switch, part number 2070017, and a magnet, part number 2070026, that is attached to an actuator arm, part number 2041068. The actuator arm is mounted on a pivot, part number MS20392-3C15, and there is a small coil return spring, part number 2041064, attached at the opposite end to the magnet (Figure 1).

When the landing gears extend and enter the downlocks they mechanically move the lower ends of the actuator arms, causing them to pivot and swing the magnets towards the 'reed' switches. This extends the return springs (Figure 2).

The two electrical contacts within the 'reed' switch are pulled together by the magnetic field of the magnet, completing the downlock electrical circuit. When the landing gear is retracted, the return spring pulls the magnet away from the 'reed' switch (Figure 3) allowing the contacts to separate, breaking the downlock electrical circuit.

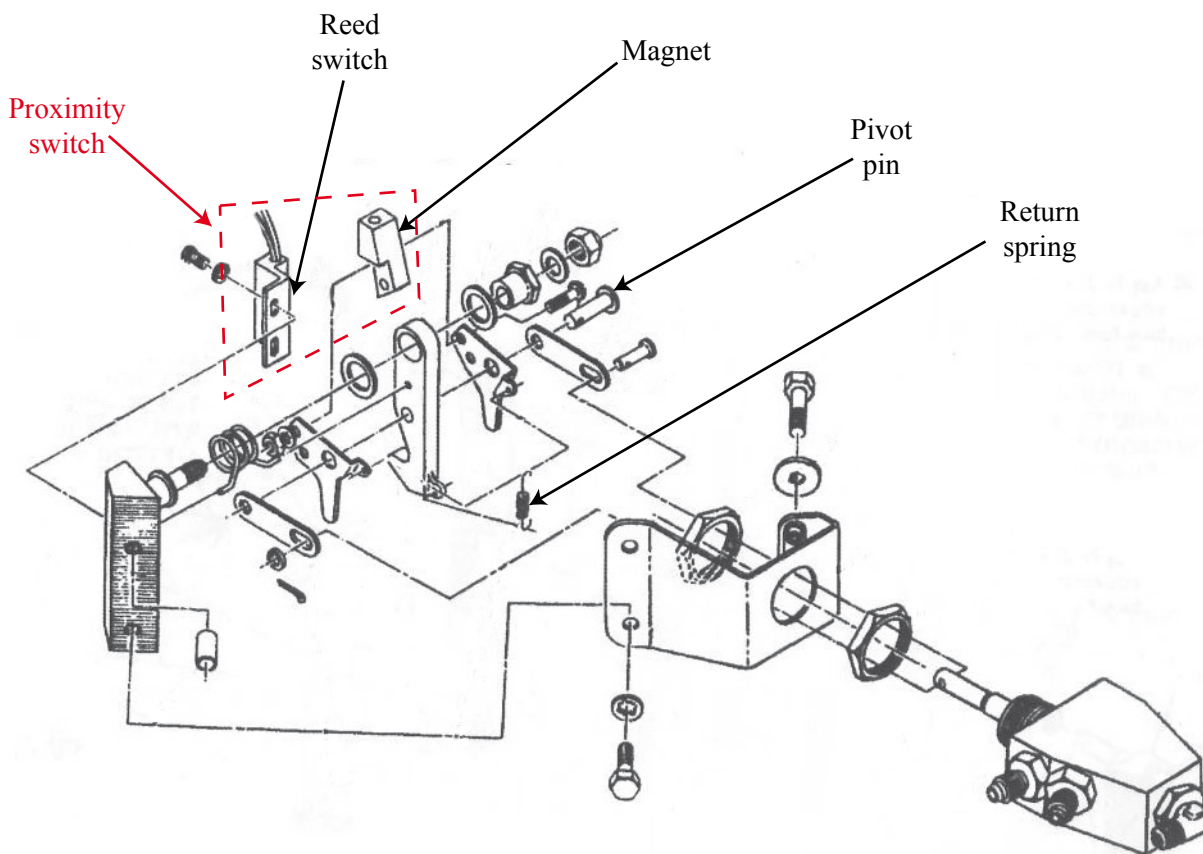

Figure 1

Main landing gear downlock mechanism

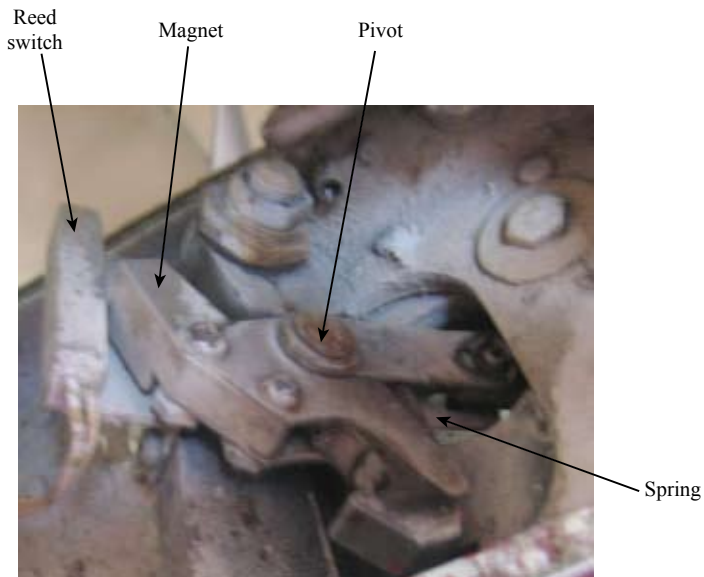

Figure 2

Downlock proximity switch in the 'landing gear extended' position

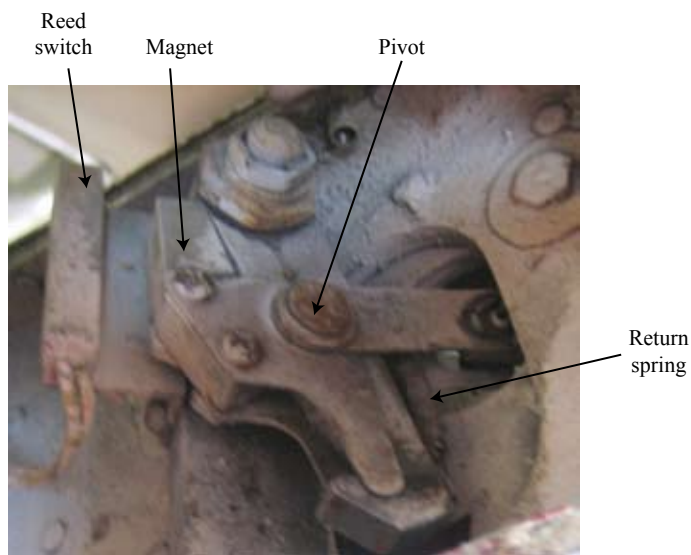

Figure 3

Right landing gear downlock proximity switch in the 'landing gear retracted' position

The nose landing gear downlock proximity switch is similar to the main landing gear switch in that it consists of a 'reed' switch and a magnet. The 'reed' switch is attached to the engine/nose landing gear attachment frame and the magnet to the nose landing gear. The magnet is positioned in the proximity of the 'reed' switch when the nose landing gear leg is in the fully extended position.

All three landing gears swing forward from their retracted positions when they extend to their DOWN AND LOCKED positions. The design of the hydraulic system sequences the landing gear extension, which results in the nose landing gear achieving the DOWN AND LOCKED position before the main landing gears have achieved half their extension travel.

The downlock proximity switches were only fitted to the French manufactured F177RG aircraft. The 177RG aircraft that were manufactured in the USA, have a downlock system that utilises an electro/mechanical mechanism.

Engineering examination

The engineering examination of G-BFPZ revealed that both main landing gear downlock proximity switches remained in the DOWN AND LOCKED position when the landing gear was retracted. Closer inspection found that the pivot points were dry, with no evidence of lubrication, and the return springs were weak.

A number of landing gear retraction and extension cycles were performed and it was found that when performing the extension cycle that the nose landing gear would achieve the DOWN AND LOCKED position and the hydraulic pump would switch OFF leaving the main landing gears in a partially extended position with the cockpit green landing gear DOWN AND LOCKED light illuminated. On

each occasion this occurred it was found that both main landing gear downlock proximity switches were in the DOWN AND LOCKED positions. Movement of either of these switches away from the DOWN AND LOCKED position resulted in the hydraulic pump switching ON, the cockpit green DOWN AND LOCKED light goes out and the landing gears moving to their DOWN AND LOCKED position.

Previous accident

This aircraft was in a previous accident involving main landing gear retraction on landing at Swansea Airport, Wales, in April 2008 (AAIB Bulletin 8/2008). At the time there was no engineering investigation carried out.

Previous maintenance

Following the accident at Swansea Airport, the aircraft, which was based there, was lifted, the landing gear was extended and the aircraft was parked in its normal place. Later in the year the aircraft was sold and the new owner flew it on a 'one-off ferry flight', with the landing gear extended, to an aircraft maintenance organisation based in another part of Wales. This maintenance organisation carried out repairs to the damage caused during the accident and inspected the landing gear system and found no faults. They also carried out an Annual Inspection and Airworthiness Review, in accordance with CAA/LAMP/A/2007 issue 1. During this period of repair and maintenance the landing gear was cycled six or seven times and no fault was found.

Other information

The accident, that is the subject of this report, occurred on the seventh landing following the repair and maintenance.

The aircraft was manufactured in 1973 and at the time of the accident had flown 2,956 hours. A simple calculation

shows that the aircraft had been airborne, generally with the landing gear retracted, for approximately 0.13% of the time since it was manufactured. This means that the main landing gear downlock proximity switch return springs had been in a 'stretched' condition for about 99.9% of the 36 years that they were fitted to the aircraft. This would allow the springs to 'set' towards the 'stretched' position, which would weaken them. There was no indication that these springs had been replaced since the aircraft was manufactured.

Manufacturer's maintenance requirements

There is no specific requirement to lubricate the main landing gear downlock proximity switch pivot points and there is no replacement requirement for the main landing gear downlock proximity switch return springs.

Safety recommendations

To help prevent the main landing gear downlock proximity switches staying in the landing gear DOWN AND LOCKED position when the landing gear is retracted the following Safety Recommendations are made:

Safety Recommendation 2010-050

It is recommended that the Cessna Aircraft Company introduce a specific maintenance requirement for F177RG aircraft to lubricate the main landing gear downlock proximity switch pivot (part number MS20392-3C15).

Safety Recommendation 2010-051

It is recommended that the Cessna Aircraft Company specify a calendar life for the main landing gear downlock proximity switch return spring (part number 2041064) fitted to F177RG aircraft.

ACCIDENT

| | | |
|--|---|-------------------|
| Aircraft Type and Registration: | DH82A Tiger Moth, G-ALWW | |
| No & Type of Engines: | 1 De Havilland Gipsy Major 1C piston engine | |
| Year of Manufacture: | 1943 | |
| Date & Time (UTC): | 21 April 2010 at 1040 hrs | |
| Location: | Bidford, Warwickshire | |
| Type of Flight: | Private | |
| Persons on Board: | Crew - 1 | Passengers - None |
| Injuries: | Crew - None | Passengers - N/A |
| Nature of Damage: | Propeller strike, left wing interplane struts and flying wires damaged | |
| Commander's Licence: | Airline Transport Pilot's Licence | |
| Commander's Age: | 63 years | |
| Commander's Flying Experience: | 15,912 hours (of which 170 were on type) Last 90 days - 10 hours Last 28 days - 7 hours | |
| Information Source: | Aircraft Accident Report Form submitted by the pilot | |

During the final stages of taxiing for departure the pilot of the Tiger Moth gave way to a glider under tow. Once clear, and as he manoeuvred the Tiger Moth onto the grass runway, it collided with a Pawnee aircraft parked near the start of the runway. Both the Tiger Moth and Pawnee

were damaged but there were no injuries. The pilot reported that his lookout may have been compromised by his attention becoming focussed on the glider under tow and on avoiding disturbing a second parked glider with his propeller slipstream.

ACCIDENT

| | | |
|--|--|-------------------|
| Aircraft Type and Registration: | Diamond DA 42 Twin Star, G-CDKR | |
| No & Type of Engines: | 2 Thielert TAE 125-01 piston engines | |
| Year of Manufacture: | 2005 | |
| Date & Time (UTC): | 24 March 2010 at 1038 hrs | |
| Location: | Crossland Moor Airfield, near Huddersfield, Yorkshire | |
| Type of Flight: | Private | |
| Persons on Board: | Crew - 1 | Passengers - None |
| Injuries: | Crew - None | Passengers - N/A |
| Nature of Damage: | Aircraft damaged beyond economic repair | |
| Commander's Licence: | Commercial Pilot's Licence | |
| Commander's Age: | 25 years | |
| Commander's Flying Experience: | 1,213 hours (of which 70 were on type) Last 90 days - 17 hours Last 28 days - 2 hours | |
| Information Source: | Aircraft Accident Report Form submitted by the pilot and subsequent AAIB telephone enquiries | |

Synopsis

Whilst taking off, the pilot could not rotate the aircraft and insufficient runway remained in which to stop safely. A runway excursion ensued with the aircraft being damaged beyond economic repair. The pilot was uninjured.

Following the accident no technical or operational deficiencies could be identified.

History of the flight

The pilot elected to depart from Runway 25 for his intended flight to Elstree Aerodrome. His performance calculations, including an allowance for a 2.6% upslope, resulted in a still air Take Off Distance Required (TODR),

to 50 ft, of 528 m; the ground roll element of which was 363 m. The surface wind was estimated to be from 190° at 13 kt, giving a 7kt headwind. The pilot calculated that this reduced the TODR and ground roll by approximately 20 m. The aircraft's takeoff weight was 1,603 kg and the CG was in the middle of the flight range. All the flying control trims were set to the takeoff position.

Runway 25 consists of a 600 m asphalt surface and a further 250 m of grass at its upwind end. The pilot reported that he had previously flown the aircraft from the runway at higher weights without difficulty, normally becoming airborne with about 100 m of the asphalt surface remaining.

The pilot stated that he conducted a thorough pre-flight inspection, with no defects identified. The engine start and associated checks, which included a check of the trim system, autopilot and elevator variable backstop, were normal and he backtracked Runway 25 to use the full length. The pilot used the Aeroplane Flight Manual (AFM) technique for the takeoff; the flaps were retracted and full power was selected before brake release. Both engines developed the expected (full) power with 2340-2350 rpm indicated and, at that stage, the pilot considered there to be nothing unusual. The aircraft achieved the planned V_R (the rotation speed) of 70 kt with approximately 100 m of paved runway surface remaining. The pilot then attempted to rotate the aircraft, however, he reported that there was no perceptible pitch change. Having cross-checked the airspeed, now 75-80 kt, with the right seat ASI, he attempted to rotate the aircraft again but there was still no response.

As the aircraft crossed from the paved to grass surface of the runway, the pilot made a third unsuccessful attempt to rotate the aircraft. The increased drag, as the aircraft entered a softer area of grass, reduced the acceleration and the speed remained at around 75-80 kt. The pilot then rejected the takeoff, selecting idle power on both engines and applied the brakes. As the aircraft approached the end of the runway, the pilot turned the aircraft to the right, at a speed of about 50 kt, and the aircraft slid sideways into a gully in the runway overrun.

The pilot shut down both engines, turned off the fuel and isolated the electrical supplies, and evacuated the aircraft via the main canopy, uninjured.

Aircraft damage

The aircraft sustained extensive damage. This included a fracture in the fuselage behind the cockpit, detachment

of the aft fuselage, collapsed landing gear, shattered propellers and damage to the left wing. The cockpit area remained intact, protecting the pilot from injury. There was no fire.

Manufacturer's inspection

The aircraft manufacturer's UK representative conducted a limited survey of the aircraft following the accident. The survey included an inspection of the elevator control runs. Although the pushrod was deformed by the fuselage damage, no other defects were found. Also, the right engine Electronic Control Unit (ECU) was downloaded and no anomalies were revealed. The Left engine ECU could not be downloaded due to damage sustained in the accident.

Manufacturer's Airplane Flight Manual

The DA42 Airplane Flight Manual states:

'For a safe take-off the available runway length must be at least equal to the take-off distance over a 50 ft (15 m) obstacle...

***Note** An uphill slope of 2 % (2 m per 100 m or 2 ft per 100 ft) results in an increase in the take-off distance of approximately 10 %. The effect on the take-off roll can be greater.'*

Discussion

No technical defects could be identified by the manufacturer following the accident. Likewise, no operational deficiencies were highlighted by the pilot. As such it was not possible to determine why the aircraft would not take off. The pilot considered that local winds effects may have been involved, although turbulence is usually experienced with northerly winds.

ACCIDENT

| | | |
|--|---|-------------------|
| Aircraft Type and Registration: | Jabiru J400, G-CDLS | |
| No & Type of Engines: | 1 Jabiru Aircraft PTY 3300A piston engine | |
| Year of Manufacture: | 2006 | |
| Date & Time (UTC): | 19 May 2010 at 0944 hrs | |
| Location: | Hinderwell, Yorkshire | |
| Type of Flight: | Private | |
| Persons on Board: | Crew - 1 | Passengers - 1 |
| Injuries: | Crew - None | Passengers - None |
| Nature of Damage: | Propeller destroyed, lower fuselage, cowlings, engine attachment and landing gear damaged | |
| Commander's Licence: | National Private Pilot's Licence | |
| Commander's Age: | 69 years | |
| Commander's Flying Experience: | 776 hours (of which 88 were on type) Last 90 days - 4 hours Last 28 days - 4 hours | |
| Information Source: | Aircraft Accident Report Form submitted by the pilot | |

Synopsis

The aircraft was damaged during a forced landing following an engine malfunction. Carburettor icing may have been a factor.

History of the flight

The aircraft took off from Fishburn Airfield at around 0725 hrs with the pilot and one passenger aboard and approximately 60 litres of Avgas for a flight to Scarborough and back. On the return leg, flying at a height of approximately 1,000 ft north-west of Whitby, the engine began "misfiring severely". At 0812 hrs the pilot transmitted a MAYDAY and selected a field to the east of the aircraft in which to make a forced landing. Whilst flying downwind he judged that the aircraft was

too low to continue the approach as intended and turned the aircraft sharply left into wind. Before completing the turn the aircraft impacted the ground, coming to rest on the front left portion of its fuselage following the failure of its nose and left landing gear legs. During the short ground travel the engine "started to rev up", so the pilot switched it off before vacating the aircraft with the passenger using the door on the right of the cabin. There was no fire and the uninjured occupants were able to signal to a Coast Guard helicopter that attended shortly afterwards. Police and the Ambulance service attended later.

Aircraft information

The aircraft was constructed by the pilot from a kit. The kit manufacturer states in information available online that the engine type fitted to this aircraft has a fuel consumption of approximately 26 litres per hour at 75% cruise power, noting that the actual figure will 'vary depending on installation, propeller and power settings'. The engine is equipped with a means of heating the carburettor to reduce ice accretion.

The aircraft was recovered two days after the accident by an engineer who was familiar with the type. While dismantling it he drained approximately 27 litres of fuel from its wing tanks. During an informal examination he also determined that the engine could be turned freely and exhibited compression in each of its cylinders.

Meteorological information

A meteorological report valid at 0820 hrs for Durham Tees Valley Airport, 24 nm west of the accident site,

indicated a surface wind from 200° at 5 kt, visibility in excess of 10 km with no cloud reported below 4,000 ft, a temperature of 14°C and dew point 8°C.

Discussion

Engine malfunction

Given the quantity of fuel recovered from the aircraft after the accident it is unlikely that the loss of power in flight was due to lack of fuel onboard. The findings of the informal engine inspection, and the pilot's report that the engine "started to rev up" on the ground, indicate that the engine had not suffered a serious mechanical failure prior to impact.

In his report of the accident the pilot observed that the loss of power in flight may have been caused by carburettor icing. Safety Sense Leaflet 14 – 'Piston Engine Icing', published by the CAA, discusses the phenomenon and suggests procedures for minimising its effects. It includes the figure reproduced below.

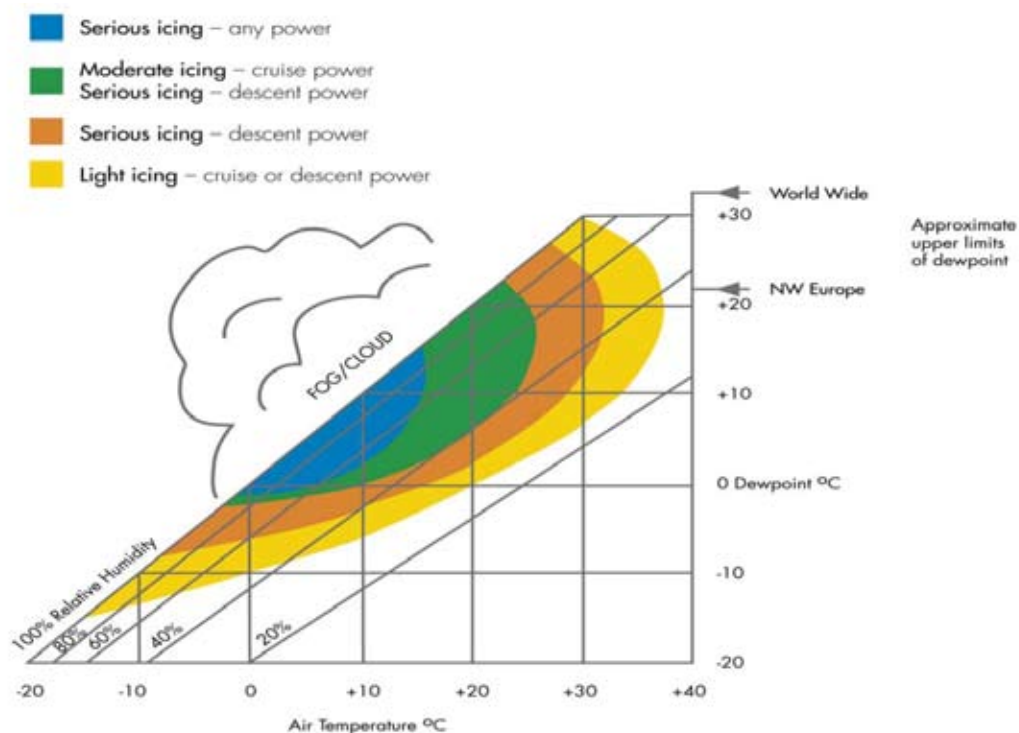

Figure 1

Carburettor icing as a function of temperature and dew point

The combination of temperature and dew point reported at Durham Tees Valley is conducive to moderate carburettor icing at cruise power and is close to combinations that might give rise to severe icing at any power.

A more comprehensive exploration of the issue of induction system icing is included in the report on the accident to G-AVNP on 28 April 2001, published by the AAIB in its January 2004 bulletin. The report on the accident to G-BAOS on 30 May 2006, published in the September 2006 bulletin, includes the following statement from the Civil Aviation Authority Safety Regulation Group Safety Plan 2006:

'Since 1976 Carburettor Icing has been a contributory factor in 14 fatal accidents and in over 250 other occurrences in the UK with numerous AAIB recommendations to SRG. Progress has repeatedly been hampered by the lack of data on where ice forms, how quickly and how much heat is effective in removing it. There has also been some doubt that the level of carburettor heat required by the Airworthiness Requirements (e.g. EASA CS-23) is adequate to mitigate the risk. CAA has conducted research using a specially designed carburettor test rig in conjunction with Loughborough University and an industry partner for systematic data collection. The CAA will publish a report on carburettor icing, including potential mitigation.'

The target date for reporting on this work, stated elsewhere in the Plan, was February 2007. In the Safety Plan Update 2007 and 2008 this was successively revised to April 2009. The Safety Plan 2009/11 listed the work as "on hold", to be reviewed when resources become available.

Forced landing

Safety Sense Leaflet 07 – 'Aeroplane Performance' includes a consideration of issues associated with forced landing, noting in particular that:

'Since an engine failure or power loss (even on some twin-engined aircraft) may result in a forced landing, this must be borne in mind during all stages of the flight.'

And

'A forced landing under control is infinitely preferable to the loss of directional control.'

ACCIDENT

| | | |
|--|--|-------------------|
| Aircraft Type and Registration: | Mooney M20F Executive, G-CEJN | |
| No & Type of Engines: | 1 Lycoming IO-360-A1A piston engine | |
| Year of Manufacture: | 1966 | |
| Date & Time (UTC): | 8 August 2009 at 1218 hrs | |
| Location: | Wellesbourne Mountford Airfield, Warwickshire | |
| Type of Flight: | Private | |
| Persons on Board: | Crew - 1 | Passengers - None |
| Injuries: | Crew - None | Passengers - N/A |
| Nature of Damage: | Damage to the engine cowling, cowl flaps, propeller, nose landing gear, lower fuselage, wing and the engine shock-loaded | |
| Commander's Licence: | Private Pilot's Licence | |
| Commander's Age: | 39 years | |
| Commander's Flying Experience: | 106 hours (of which 14 were on type) Last 90 days - 31 hours Last 28 days - 4 hours | |
| Information Source: | AAIB Field Investigation | |

Synopsis

The flight was for the pilot/owner to verify the satisfactory operation of the landing gear system following the replacement and subsequent adjustment of a landing gear limit switch. After a successful test flight, during which the landing gear was cycled three times, the pilot returned to the departure airfield. A final landing check was carried out during which the pilot confirmed that the landing gear was DOWN AND LOCKED. A normal flare and touchdown on the mainwheels was carried out and the nosewheel gently lowered onto the runway. After a short period (a second or two) the propeller struck the runway, stopping the engine. The pilot noticed that neither the green landing gear DOWN AND LOCKED nor

the amber IN TRANSIT lights were illuminated. The aircraft slid along the runway centreline on its lower fuselage for about 100 metres before swinging through 90° to the left and coming to rest.

Examination of the aircraft revealed that the retention link, part number 53001-013, an item in the landing gear downlock system, had been fitted upside down.

History of the flight

The flight was a one-hour local VFR flight and was for the pilot/owner to verify the satisfactory operation of the landing gear system following the replacement, and

subsequent adjustment, by a maintenance organisation of a landing gear limit switch. Following a normal departure the pilot levelled the aircraft at 3,000 ft, at a speed of approximately 95 kt, and commenced cycling the landing gear. He carried out three extensions/retractions using the normal landing gear system and all indications were satisfactory. After the third retraction the pilot reduced the engine power and the aircraft's speed and checked that the landing gear warning horn operated satisfactorily, which it did.

Following these satisfactory landing gear checks the pilot flew the aircraft back to the departure airfield. As the aircraft entered the airfield overhead position he extended the landing gear and noted that the green DOWN AND LOCKED light was illuminated and the visual landing gear position indicator showed that it was in the extended position. He also noted that the aircraft's speed reduced due to the drag of the extended landing gear. A normal circuit and approach to Runway 18 was carried out and after turning the aircraft onto the final approach the pilot selected the third stage of flap. ATC gave the pilot clearance to land at his discretion and gave the wind as 270° less than 5 kt.

The pilot carried out a final landing check, during which he confirmed that the green landing gear DOWN AND LOCKED light was illuminated and the visual landing gear position indicator showed that it was in the extended position. A normal flare and gentle touchdown on the mainwheels was carried out at about 65 kt and the nosewheel gently lowered onto the runway. After a short period (a second or two) the propeller struck the runway, stopping the engine. The pilot noticed that neither the green landing gear DOWN AND LOCKED nor the amber IN TRANSIT lights were illuminated. The aircraft slid along the runway centreline on its lower fuselage for about 100 metres before swinging through 90° to the left and coming to rest. After making a

PAN call the pilot selected the electric master switch OFF and safely evacuated the aircraft.

The AFISO observed the landing and confirmed that it appeared to be normal.

Engineering examination

Airfield staff who attended, and subsequently recovered the aircraft, found that all three landing gears had collapsed and that the weight of the aircraft was being held on the propeller and the lower rear fuselage. They also noted that the landing gear selector in the cockpit was in the DOWN position. When the aircraft was lifted all three landing gears partially extended under gravity. An attempt was made to lower the gear using the manual gear extension system, but it was ineffective. After applying sustained physical force to the landing gear legs, the airfield staff managed to get them into their extended positions and the aircraft was towed from the runway.

The aircraft's landing gear downlock is only fitted to the nose landing gear. The main landing gears are attached to the nose landing gear by a series of rods which allows the nose landing gear downlock to retain the main landing gears in the DOWN position.

Further examination by the local aircraft engineering staff and the AAIB found that the nose landing gear downlock mechanism would not engage into the full overcentre position due to mechanical interference. This resulted in a 'soft' downlock. Further examination by the maintenance organisation revealed that the nose landing gear downlock Retraction Link, part number 53003-013 (Figure 1), was fitted upside down and did not have either of the two grease nipples fitted in their threaded holes¹. In the illustration (Figure 1) the Retraction Link,

Footnote

¹ The aircraft manufacturer has not been informed of any previous events where the retraction link has been fitted incorrectly.

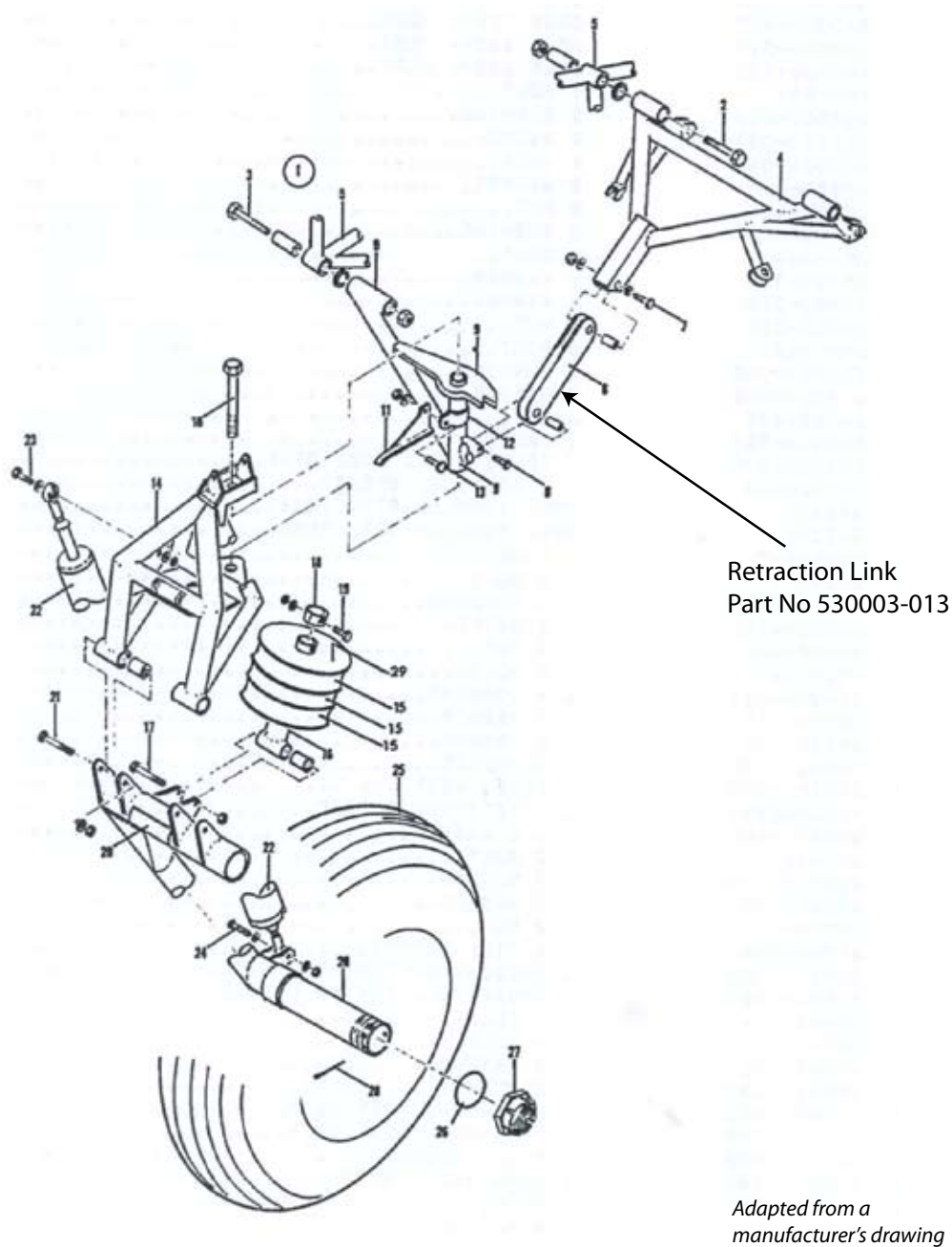

Figure 1
Nose landing gear assembly

part number 530003-013, appears symmetrical but the difference in profile between the upper and lower surfaces requires correct orientation during assembly.

After correctly fitting the retraction link the downlock mechanism went into a 'hard' overcentre lock (Figure 2).

Maintenance and Parts Manuals

Neither the Maintenance Manual nor the Parts Manual gives any guidance on the correct orientation of the Retraction Link, part number 530003-013, when fitted to the aircraft. There are no pictures or diagrams showing the grease nipples fitted to the retraction link and there is

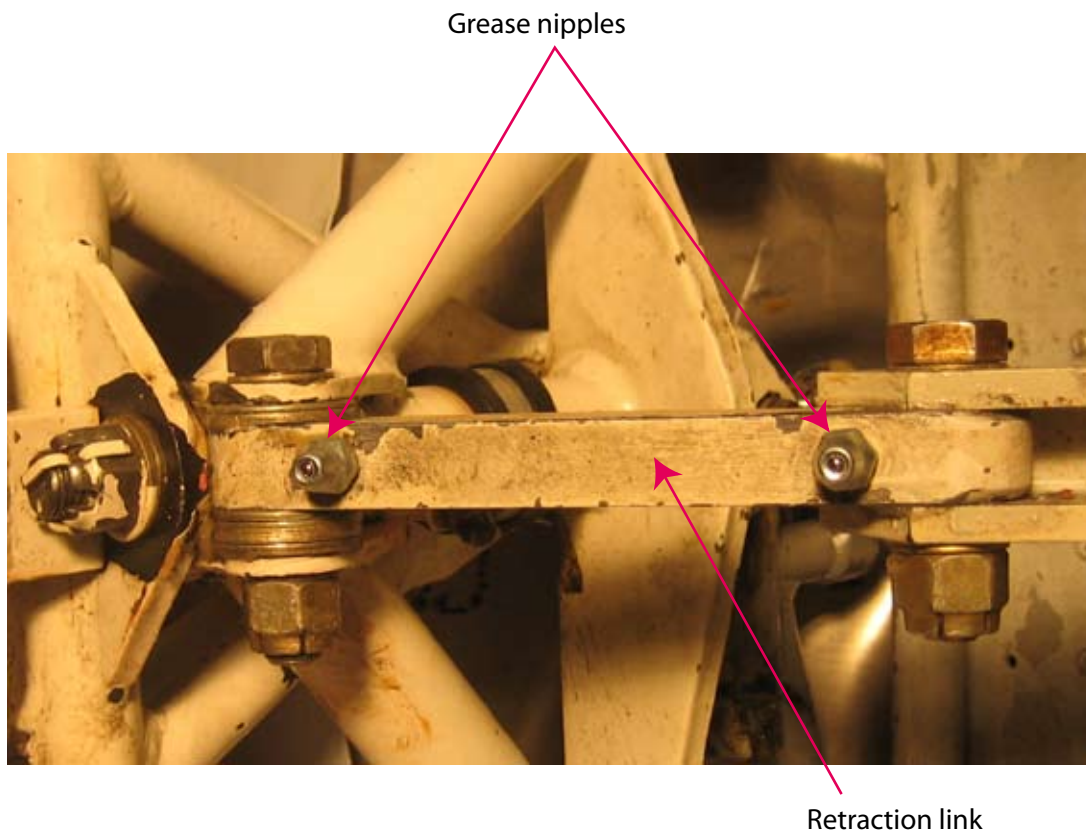

Figure 2

Nose landing gear retraction link with grease nipples fitted and correctly orientated

no listing for the grease nipples within the Parts Manual. The aircraft manufacturer has stated that they supply the Retraction Link with the grease nipples fitted.

Other information

The aircraft, which was on the French register, was involved in an accident on 22 June 2001 at Etempts, France which resulted in the collapse of all three landing gears. The wreckage was transported to the UK where extensive repairs were carried out over a number of years and the aircraft eventually placed on the UK register in February 2007. Four days prior to the accident (8 August 2009) that is the subject of this report, there was a problem with the landing gear in that it would not extend using the electrical system; it had to be extended manually. An engineering investigation by a local maintenance organisation found that the down

limit microswitch, located in the area of the electric extension/retraction mechanism, had failed, which was replaced and adjusted. A number of static landing gear extension and retraction tests were carried out and the system was found to perform satisfactorily.

The aircraft had flown 51 hours since the major repair following the accident in France and the date of this accident.

Safety Recommendation 2010-044

It is recommended that the Federal Aviation Administration require the aircraft manufacturer, Mooney Airplane Company, to publish guidance material on the correct orientation of the nose landing gear Retraction Link part number 530003-013.

ACCIDENT

| | | |
|--|--|-------------------|
| Aircraft Type and Registration: | Pierre Robin HR100/210 Safari II, G-BLWF | |
| No & Type of Engines: | 1 Continental Motors Corp IO-360-D piston engine | |
| Year of Manufacture: | 1973 | |
| Date & Time (UTC): | 17 April 2010 at 1511 hrs | |
| Location: | Bourn Airfield, Cambridgeshire | |
| Type of Flight: | Private | |
| Persons on Board: | Crew - 1 | Passengers - None |
| Injuries: | Crew - None | Passengers - N/A |
| Nature of Damage: | Right landing gear detached from spar and bent back into wing and flap. Nose gear and frame pushed up into engine bay and firewall | |
| Commander's Licence: | Private Pilot's Licence | |
| Commander's Age: | 66 years | |
| Commander's Flying Experience: | 808 hours (of which 2 were on type) Last 90 days - 2 hours Last 28 days - 2 hours | |
| Information Source: | Aircraft Accident Report Form submitted by the pilot | |

Synopsis

The aircraft contained about 50 litres of fuel in each of the inner wing tanks, with the outer wing tanks virtually empty. For the flight, the pilot selected the left outer tank on the fuel selector cock in the mistaken belief that this was the position for the left inner tank. The identification placard on the fuel selector cock was badly scratched and barely legible. After 35 minutes of flight the engine began to misfire, prompting the pilot to head back to the airfield, approximately five miles away. A short distance from the runway the engine stopped and the aircraft landed heavily in a field of crops. The aircraft suffered significant damage to the right and nose landing gear and also to the right wing, engine bay and firewall. The pilot was uninjured.

History of the flight

Prior to the flight, the pilot checked the contents of each of the aircraft's fuel tanks by reading the fuel gauges and physically checking the fuel level in the left inner tank. He noted that the gauges indicated about 50 litres in each of the inner tanks and just above empty in the outer tanks. For the flight the pilot selected the left outer tank on the fuel selector cock in the mistaken belief that this was the position for the left inner tank. The Figure 1 shows the fuel cock with the left inner tank (INT L) selected. The next position anticlockwise is the left outer tank (AUX L) that was selected.

The pilot took off from the airfield for a local flight to familiarise himself with the handling qualities of the

aircraft (which he had purchased four days earlier). About 35 minutes later, approximately five miles south of the airfield, the engine started to misfire. The pilot confirmed that engine temperature and oil pressure were normal and that the fuel contents in the tank he thought he had selected (left inner) were sufficient. He then turned on the fuel pump and checked his selection of fuel tank¹. The engine misfire stopped briefly with the fuel pump on but then resumed, so the pilot turned the pump off and headed back towards the airfield.

As the pilot lined up with the runway the engine stopped and, unable to reach the airfield, the aircraft crash landed heavily in a field of crops, 150 metres short of the runway. During the landing the right landing gear detached for the wing spar and folded backwards into the wing and flap and the nose gear assembly was pushed upwards into the engine bay and firewall. The pilot, who was wearing a full harness, was uninjured.

Fuel system

The aircraft's fuel system consists of two (inner) wing-mounted tanks and two auxiliary (outer) wing-mounted tanks, each with a maximum fuel capacity of 113.5 litres and separate fuel gauges on the instrument panel labelled L INTERIEUR, L SUP, R SUP and R INTERIEUR. Fuel tank selection is made with a fuel-selector cock located on the cockpit floor (see Figure 1) with five positions labelled OFF, INT L, AUX L, AUX R and INT R. The flight manual includes a diagram

Footnote

¹ The pilot remembered that the flight manual recommended the use of left inner tank because surplus fuel from the fuel injection dump is returned to this tank; however, this recommendation was "for start-up and take-off whenever this tank is full. The use of any other tanks may lead to overflowing in the left main tank and the loss of fuel when overfull."

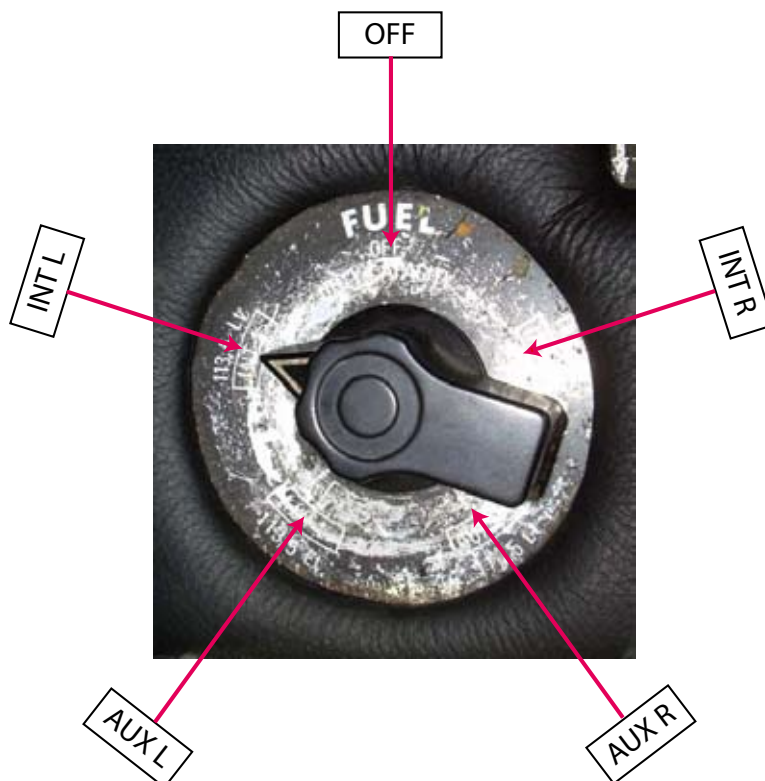

Figure 1

Fuel selector clock

of the fuel system and illustrates the fuel cock with the five selections in the same relative position to that on the actual selector cock; however, these positions are not explicitly labelled. As can be seen in Figure 1, the identification placard for the five detent positions of the fuel selector in G-BLWF was badly scratched and barely legible.

The pilot's assessment of the cause of the accident was a misreading of the worn fuel selector cock placard and a misinterpretation of the aircraft's flight manual description of the fuel system.

ACCIDENT

| | | |
|--|--|-------------------|
| Aircraft Type and Registration: | Reims Cessna F172F Skyhawk, G-ASWL | |
| No & Type of Engines: | 1 Continental Motors Corp O-300-D piston engine | |
| Year of Manufacture: | 1964 | |
| Date & Time (UTC): | 3 March 2010 at 1640 hrs | |
| Location: | About 5 nm north of Swansea Airport | |
| Type of Flight: | Training | |
| Persons on Board: | Crew - 2 | Passengers - None |
| Injuries: | Crew - 1 (Minor) | Passengers - N/A |
| Nature of Damage: | Extensive | |
| Commander's Licence: | Commercial Pilot's Licence | |
| Commander's Age: | 26 years | |
| Commander's Flying Experience: | 421 hours (of which 29 were on type) Last 90 days - 54 hours Last 28 days - 27 hours | |
| Information Source: | Aircraft Accident Report Forms submitted by the flying instructor and student pilot, and further enquiries by AAIB | |

Synopsis

The accident occurred while the aircraft was engaged on an instructional flight from Manchester Barton Airport to Swansea Airport. As it neared Swansea, the aircraft experienced a loss of power and a forced landing was made in a field. When the nosewheel dug into the soft ground on landing, the aircraft tipped forward and inverted. The instructor, who was not wearing his full safety harness, sustained facial injuries.

History of the flight

An aircraft pre-flight inspection was completed at Swansea at 0745 hrs on the day of the accident. Fuel quantity was physically checked and found to be just

above 32 US gallons of useable fuel (about 80% of maximum capacity). The aircraft departed Swansea at 0810 and arrived at Barton at 0925 hrs without reported incident.

When the aircraft departed Barton at 1515 hrs, for the return flight, the fuel tanks were reportedly showing more than half full. When the aircraft was about 8 nm north of Swansea, a cruise descent was initiated from about 4,000 ft, with a mid-range power setting and carburettor heat not selected. As the aircraft passed about 2,000 ft, engine rpm suddenly dropped to 1,500. The instructor took control and carried out immediate actions, and the

rpm increased briefly to about 1,600. The student applied carburettor heat. All other indications were normal, and the instructor reported that the fuel level was at less than a quarter full in each tank. Alternate selection of left then right fuel tanks had no effect.

The instructor transmitted a MAYDAY call and prepared to land at a nearby farm strip. Passing 800 ft, with rpm still at 1,500, it became apparent that the aircraft would not be able to reach the intended strip. The instructor selected the only flat field where an into-wind landing could be carried out and made an approach to it. Touchdown reportedly occurred on the main wheels at 55 kt and the instructor attempted to delay nosewheel touchdown with full aft elevator. However, when the nosewheel lowered, it dug into the soft ground and the aircraft overturned.

The aircraft was fitted with lap belts and diagonal shoulder straps. However, the instructor was not wearing the diagonal strap. Consequently, he suffered facial injuries in the accident, while his student, who was using the full restraint, was uninjured. The accident attracted a full response from the emergency services, and the occupants were treated by paramedics of the air ambulance helicopter.

In a separate report, the student pilot, who had 11 hours flight time, described drawing his instructor's attention to the left tank fuel gauge before departing from Barton. This was reading below half full, and the instructor pointed out that the right tank gauge was reading slightly over half full. Once airborne, as the aircraft approached Swansea but before descent was initiated, the student saw that both fuel gauges were "in the red". He pointed this out to his instructor, who reportedly did not respond. The instructor stated that he did not recall this comment.

After checking planned fuel consumption and considering the symptoms, the instructor concluded in his report that the power loss had been due to carburettor icing.

Meteorological information

At 1650 hrs, Swansea Airport reported a temperature of 6°C, dew point -1°C and clear skies. Using a chart produced by the UK CAA to predict the likelihood of carburettor icing, these conditions result in a moderate to serious risk.

Information from the aircraft recovery team

An aviation surveyor attended the accident site as part of the recovery process. He reported that the aircraft had travelled a short distance before tipping upside down, evidenced by short, deep ruts left by its main wheels and the single rut from its nosewheel. The aircraft sustained substantial damage and distortion to both mainplanes. The left wingtip appeared to have struck the ground, resulting in severe disruption of the left hand lift strut. There was further damage and distortion to the fuselage.

Both fuel tanks appeared intact, with no obvious signs of leakage or smell of fuel. When the aircraft was cleared from the site, the vegetation beneath showed no signs of fuel contamination. When the aircraft was disassembled for transport, approximately five litres of fuel were found remaining in the left tank and approximately one litre in the right tank. The fuel selector was selected to the right tank feed.

In a further report, the instructor observed that the reported fuel quantity at recovery was less than the manufacturer's quoted minimum useable fuel, suggesting that some fuel leakage may have occurred.

ACCIDENT

| | | |
|--|--|-------------------|
| Aircraft Type and Registration: | Robin DR400/180 Regent, G-CBMT | |
| No & Type of Engines: | 1 Lycoming O-360-A1P piston engine | |
| Year of Manufacture: | 2002 | |
| Date & Time (UTC): | 9 May 2010 at 1325 hrs | |
| Location: | Manston Airfield, Kent | |
| Type of Flight: | Private | |
| Persons on Board: | Crew - 1 | Passengers - None |
| Injuries: | Crew - None | Passengers - N/A |
| Nature of Damage: | Nose landing gear, propeller, engine and underside of cowling | |
| Commander's Licence: | Private Pilot's Licence | |
| Commander's Age: | 43 years | |
| Commander's Flying Experience: | 212 hours (of which 20 were on type) Last 90 days - 4 hours Last 28 days - 2 hours | |
| Information Source: | Aircraft Accident Report Form submitted by the pilot | |

Synopsis

The aircraft was departing Runway 10 with a surface wind of 020°/14 kt. As the aircraft lifted off, the left wing lifted and the right wing contacted the runway surface. The pilot closed the throttle and the nose landing gear collapsed as it struck the runway. The propeller also contacted the runway stopping the engine. The pilot was unable to maintain the runway centreline and the aircraft departed the left side of the runway. He believed that a gust of wind from the left had caught the aircraft just at the point of lift off and he had not been able to prevent the right wing touching the ground. He considered that the loss of directional control was due to the collapsed nose landing gear.

History of the flight

The pilot had flown the aircraft from Crowfield Airfield in Suffolk to Manston Airport, Kent that morning. The weather for the flight was good with the wind 020°/14 kt, visibility greater than 10 km, cloud broken at 1,100 ft, OAT 10°C, dew point 7°C and QNH 1011 hPa. Runway 10 was in use which is 2,752 metres long and 61 metres wide and the pilot landed in the prevailing crosswind conditions without difficulty. The surface wind was within the crosswind limits for the aircraft which had been demonstrated up to 24 kt.

After a few hours on the ground, the pilot taxied to Runway 10 for departure. He had selected the first

stage of flap for the takeoff and lined up on the runway centreline. When cleared for takeoff, he smoothly selected takeoff power and the aircraft accelerated along the runway remaining on the centreline. The aircraft began to lift off and very quickly the left wing lifted causing the right wing tip to contact the runway. The pilot closed the throttle and the aircraft sank back to the runway. The nose landing gear collapsed, the propeller struck the runway and the engine stopped. The aircraft veered to the left and despite the pilot's attempts to keep the aircraft straight, he was unable to prevent it departing the left side of the runway. When the aircraft came to a stop, the pilot isolated the fuel

and electrical systems and vacated the aircraft through the normal exit. The airfield Rescue and Fire Fighting Service deployed and were quickly on the scene.

Whilst the pilot could not remember the detail of the events, due to the speed with which the incident happened, he considered that, as he lifted off, the aircraft was caught by a gust of wind from the left which he was unable to counteract. When he closed the throttle, the aircraft sank back onto the runway collapsing the nose landing gear, which caused the aircraft to veer to the left.

ACCIDENT

| | | |
|--|---|-------------------|
| Aircraft Type and Registration: | Streak Shadow SA, G-WYAT | |
| No & Type of Engines: | 1 Rotax 618 piston engine | |
| Year of Manufacture: | 1998 | |
| Date & Time (UTC): | 4 April 2010 at 1740 hrs | |
| Location: | Oban Airport, Scotland | |
| Type of Flight: | Private | |
| Persons on Board: | Crew - 1 | Passengers - None |
| Injuries: | Crew - None | Passengers - N/A |
| Nature of Damage: | Substantial damage to the main boom near the wing trailing edge | |
| Commander's Licence: | National Private Pilot's Licence | |
| Commander's Age: | 30 years | |
| Commander's Flying Experience: | 380 hours (of which 35 were on type) Last 90 days - 20 hours Last 28 days - 7 hours | |
| Information Source: | Aircraft Accident Report Form submitted by the pilot | |

The aircraft had performed several circuits at Oban Airport in clear visibility with an 11 kt wind from 220°. The pilot then elected to practise short field landings on Runway 19. During the first approach, the aircraft encountered what the pilot considered to be windshear so he applied full engine power and performed a go-around. During the second approach the aircraft encountered windshear in the same area, but the pilot was unable to arrest the rate of descent in time, leading to a heavy

landing on the aircraft's main landing gear. The damage to the main boom was discovered after he had taxied the aircraft back to a hangar.

The pilot, wearing a four-point harness, sustained no injuries. He considered that the heavy landing was caused by applying insufficient engine power to arrest the rate of descent during the landing.

ACCIDENT

| | | |
|--|--|-------------------|
| Aircraft Type and Registration: | YAK-50, G-YAKK | |
| No & Type of Engines: | 1 Ivchenko Vedeneyev M-14P piston engine | |
| Year of Manufacture: | 1985 | |
| Date & Time (UTC): | 10 April 2010 at 1142 hrs | |
| Location: | Bothel, Cumbria | |
| Type of Flight: | Private | |
| Persons on Board: | Crew – 1 | Passengers - None |
| Injuries: | Crew – 1 (Minor) | Passengers - N/A |
| Nature of Damage: | Substantial | |
| Commander's Licence: | Private Pilot's Licence | |
| Commander's Age: | 37 years | |
| Commander's Flying Experience: | 412 hours (of which 56 were on type) Last 90 days - 9 hours Last 28 days - 7 hours | |
| Information Source: | Aircraft Accident Report Form submitted by the pilot | |

The aircraft was on a local flight from Carlisle Airport when the engine failed due to loss of oil pressure. The windscreen became partially obscured with an oil film but the pilot was able to make a forced landing in a field, during which the aircraft was substantially damaged. He vacated the aircraft unaided, but later attended hospital as his injuries became more apparent.

On examining the engine, the pilot identified that the oil pressure adjustment valve was missing from the oil scavenge pump housing (Figure 1). It was found in the

lower cowling with no evidence of the expected wire locking. He believed that the valve had worked loose and fallen out during the accident flight, causing the oil loss. The aircraft had recently undergone extensive maintenance which included an overhaul of the oil scavenge pump assembly. Initial flights following this work revealed a small oil leak in the area of the pump, which at the time, was thought to be have been remedied by an engineer tightening the small vertical bolts adjacent to the pressure adjustment valve.



Figure 1

Photograph of oil scavenge pump showing missing oil pressure adjustment valve

ACCIDENT

| | | |
|--|--|-------------------|
| Aircraft Type and Registration: | Hughes 369E, G-VICE | |
| No & Type of Engines: | 1 Allison 250-C20B turboshaft engine | |
| Year of Manufacture: | 1989 | |
| Date & Time (UTC): | 24 May 2010 at 1643 hrs | |
| Location: | Poundsgate, Devon | |
| Type of Flight: | Private | |
| Persons on Board: | Crew - 1 | Passengers - None |
| Injuries: | Crew - 1 | Passengers - N/A |
| Nature of Damage: | Extensive | |
| Commander's Licence: | Private Pilot's Licence | |
| Commander's Age: | 70 years | |
| Commander's Flying Experience: | 1,164 hours (of which 479 were on type) Last 90 days - 19 hours Last 28 days - 6 hours | |
| Information Source: | Aircraft Accident Report Form submitted by the pilot and additional AAIB inquiries | |

Synopsis

The pilot was making a different approach into a field he had used previously and failed to see a set of power cables. The aircraft struck the cables, which broke before the aircraft struck the ground.

Circumstances of the accident

The aircraft took off from a private site near Exeter and flew to another private site, located next to an inn in a hamlet northwest of Newton Abbot in Devon. The pilot had flown there on previous occasions but the field he normally used had been ploughed, forcing him to land in an adjacent field to the north. This field was bordered on its northern edge by a line of trees some 80 ft high, with a gap in the centre approximately 25 yards wide. The

wind conditions on the day of the accident necessitated the approach to the field to be made from the north, over the trees. Although the pilot had also landed previously in this field, he had used the open area at the opposite end from the trees. However, on this occasion, the presence of horses made him decide to aim for the northern end of the field. Accordingly, he decided to approach through the gap in the line of trees. The pilot stated that, at an airspeed of around 45 kt, the aircraft struck some power cables that were suspended approximately 50 ft above the ground. The cables became trapped between the skids and the fuselage underside, with the tension partially arresting the forwards motion of the aircraft before breaking. The aircraft struck the ground and

disintegrated, with the cockpit area, which remained relatively intact, rolling some 85 yards before coming to rest. The pilot's harness remained secure during the impact and he was able to extricate himself, having suffered minor injuries.

A bystander who had witnessed the accident, and who was also a pilot, ran over to the wreckage and assisted the pilot in shutting down the engine, which had continued to run after the impact.

The pilot stated that, although he had not attempted a previous landing in this area of the site, he did not fly a reconnaissance circuit and had not approached over the trees before; he was thus unaware of the presence of the cables and failed to see them during the approach. He commented that a contributory factor was that the supporting poles were hidden in the trees either side of the gap.

ACCIDENT

| | | |
|--|--|-------------------|
| Aircraft Type and Registration: | Aeroprakt A22 Foxbat, G-CWTD | |
| No & Type of Engines: | 1 Rotax 912ULS piston engine | |
| Year of Manufacture: | 2004 | |
| Date & Time (UTC): | 1 May 2010 at 1130 hrs | |
| Location: | Popham Airfield, Hampshire | |
| Type of Flight: | Private | |
| Persons on Board: | Crew - 1 | Passengers - 1 |
| Injuries: | Crew - None | Passengers - None |
| Nature of Damage: | Left main gear and nose gear collapsed, damage to propeller, left wing and underside of engine | |
| Commander's Licence: | Private Pilot's Licence | |
| Commander's Age: | 74 years | |
| Commander's Flying Experience: | 507 hours (of which 107 were on type) Last 90 days - 5 hours Last 28 days - 5 hours | |
| Information Source: | Aircraft Accident Report Form submitted by the pilot, photographs of the landing and further enquiries by the AAIB | |

The accident occurred on landing on Runway 21 at Popham Airfield following an uneventful flight from Lechlade, Gloucestershire. The weather was fine with good visibility, a 12 mph south-westerly wind and high cloud. An amateur photographer was at Popham and he took a number of still images of the accident sequence. The approach was normal with a gyrocopter landing ahead of the accident aircraft. Just before touchdown the right wing was slightly low. Whilst correcting, the pilot stated that his attention was drawn away from the task of monitoring the aircraft's speed and towards the gyrocopter further down the runway. The left wing

dropped and impacted the ground at about the same time the left gear struck the ground. The aircraft pivoted on the left wingtip and came to rest about 50 yards on from the initial touchdown; the left main gear and the nose gear collapsed. The pilot turned off the ignition and fuel before he and his passenger vacated the aircraft unaided. The pilot thought it likely that the wing drop was associated with stalling the wing. He did not consider there to be any causal factors associated with the aircraft's controls, engine or the proximity of the gyrocopter ahead of him.

ACCIDENT

| | | |
|--|---|-------------------|
| Aircraft Type and Registration: | EV-97 TeamEurostar UK, G-CEBP | |
| No & Type of Engines: | 1 Rotax 912-UL piston engine | |
| Year of Manufacture: | 2006 | |
| Date & Time (UTC): | 24 April 2010 at 1310 hrs | |
| Location: | Haverfordwest Airfield, Pembrokeshire | |
| Type of Flight: | Private | |
| Persons on Board: | Crew - 1 | Passengers - None |
| Injuries: | Crew - None | Passengers - N/A |
| Nature of Damage: | Damage to nose landing gear, engine firewall, cockpit floor panel and rudder pedals, and wingtips | |
| Commander's Licence: | Private Pilot's Licence | |
| Commander's Age: | 57 years | |
| Commander's Flying Experience: | 1,136 hours (of which 336 were on type) Last 90 days - 18 hours Last 28 days - 9 hours | |
| Information Source: | Aircraft Accident Report Form submitted by the pilot | |

The pilot reported that, after about 20 m of the landing roll on Runway 21, the aircraft was caught by a gust of wind. The aircraft veered off the runway to the left, departing the paved surface at an angle of about 30°. The aircraft crossed a drainage ditch, which caused considerable damage to the nose landing gear area, before coming to rest on the paved surface of

Runway 27. Following the accident the pilot estimated the average wind as southerly at 10 to 15 kt. He considered that the aircraft was affected by turbulence created by some nearby trees upwind of the area of the runway in which he touched down. He was unaware of this local effect.

ACCIDENT

| | | |
|--|--|-------------------|
| Aircraft Type and Registration: | Flight Design CTSW, G-CEKD | |
| No & Type of Engines: | 1 Rotax 912ULS piston engine | |
| Year of Manufacture: | 2007 | |
| Date & Time (UTC): | 11 April 2010 at 1530 hrs | |
| Location: | Home Farm Strip, Chipping Campden, Gloucestershire | |
| Type of Flight: | Private | |
| Persons on Board: | Crew - 1 | Passengers - None |
| Injuries: | Crew - None | Passengers - N/A |
| Nature of Damage: | Nose gear and engine mounts | |
| Commander's Licence: | Student Pilot | |
| Commander's Age: | 62 years | |
| Commander's Flying Experience: | 223 hours (of which 104 were on type) Last 90 days - 16 hours Last 28 days - 8 hours | |
| Information Source: | Aircraft Accident Report Form submitted by the pilot and further enquiries by the AAIB | |

Synopsis

During the landing flare the aircraft drifted uncorrected towards the edge of the strip. At touchdown the aircraft's main wheels dug into soft ground causing the nose gear to touch down heavily.

History of the flight

At the time of the accident Runway 03 was in use at Home Farm Strip, Ebrington, Chipping Campden, Gloucestershire and the wind was from 050° at 7 kt. Runway 03 is a grass runway cambered along its centreline and, as a result of recent heavy rain, the ground on the lower edges was softer than the centre of the strip.

After two hours of instructional flying the student pilot was briefed for a solo circuit. The takeoff, circuit and approach were uneventful. During the landing flare the left wing dropped and the aircraft drifted, uncorrected, towards the left hand edge of the strip. The main wheels touched down in the softer ground and dug in, causing the nose gear to touchdown heavily resulting in damage to it and the engine mounts. The pilot shut down and vacated the aircraft uninjured.

Instructor's comments

The instructor commented that, in hindsight, he feels he should not have sent the student solo as the crosswind and condition of the runway were unsuitable.

ACCIDENT

| | | |
|--|--|-------------------|
| Aircraft Type and Registration: | Ikarus C42 FB100, G-HIJN | |
| No & Type of Engines: | 1 Rotax 912 ULS piston engine | |
| Year of Manufacture: | 2004 | |
| Date & Time (UTC): | 9 April 2010 at 1000 hrs | |
| Location: | RAF Woodvale, Merseyside | |
| Type of Flight: | Training | |
| Persons on Board: | Crew - 2 | Passengers - None |
| Injuries: | Crew - None | Passengers - N/A |
| Nature of Damage: | Left main landing gear failed | |
| Commander's Licence: | Private Pilot's Licence | |
| Commander's Age: | 38 years | |
| Commander's Flying Experience: | 4,538 hours (of which 476 were on type) Last 90 days - 126 hours Last 28 days - 38 hours | |
| Information Source: | Aircraft Accident Report Form submitted by the pilot | |

Whilst carrying out a training flight in the Ince Blundell airfield circuit, the instructor was informed by personnel on the ground that the left main landing gear structure appeared to have failed. After completing a low pass, the ground personnel confirmed the failure so the instructor declared a PAN and diverted to RAF Woodvale, where a successful landing was carried out. Examination of

the aircraft confirmed that the left main landing gear axle had failed due to a previously unidentified crack, which had propagated in fatigue. The aircraft was used primarily for training from grass runways which, the owner believed, contributed to the crack formation and growth.

ACCIDENT

| | | |
|--|--|-------------------|
| Aircraft Type and Registration: | Mainair Blade 912, G-BZFS | |
| No & Type of Engines: | 1 Rotax 912-UL piston engine | |
| Year of Manufacture: | 2000 | |
| Date & Time (UTC): | 10 April 2010 at 1215 hrs | |
| Location: | Near Caernarfon Airport, Gwynedd | |
| Type of Flight: | Private | |
| Persons on Board: | Crew - 1 | Passengers - None |
| Injuries: | Crew - 1 (Minor) | Passengers - N/A |
| Nature of Damage: | Front end pod broken, nose wheel and structural beams distorted | |
| Commander's Licence: | Airline Transport Pilot's Licence | |
| Commander's Age: | 48 years | |
| Commander's Flying Experience: | 9,800 hours (of which 20 were on type) Last 90 days - 50 hours Last 28 days - 16 hours | |
| Information Source: | Aircraft Accident Report Form submitted by the pilot and subsequent enquiries | |

The accident flight occurred on the first flight of the day. The aircraft engine and pre-takeoff checks at Caernarfon Airport were satisfactory. The aircraft was taxied out onto Runway 02 for a departure on intersecting Runway 08. The engine temperatures and pressures were reported as normal during the rolling takeoff and the engine power was reduced from 5,300 rpm to 4,800 rpm after becoming airborne to reduce the pitch attitude. At approximately 200 ft in the climb the engine "coughed" twice and then stopped. The pilot turned to the left as there were no landing options ahead of the aircraft and declared a MAYDAY. He considered that all of his landing options were poor but he touched down successfully on a small grassed area adjacent to the airfield. However, during the landing roll, the aircraft

ran across a drainage ditch and sustained damage to the front end pod, nose wheel and aircraft structure.

The pilot had become aware of debris in the fuel tank shortly after acquiring the aircraft earlier in the year. However, he had been advised that the fuel filter would catch any debris until such time that a suitable opportunity for cleaning the system arose. The aircraft had been successfully flown on the day prior to the accident. Subsequent to the accident, debris was also found in the muslin fuel filter and in the fuel line before the filter. The source of the debris was not identified but reported as a build-up rather than solid debris.

Other than the presence of debris in the fuel system, the pilot identified other factors associated with the

accident. The use of a rolling takeoff and a reduction in power after becoming airborne resulted in the aircraft being at a lower altitude over the airport boundary which reduced the forced landing options. The pilot noted that,

for a takeoff from Runway 08, the number of reasonable options for a forced landing from low altitude was very limited.

ACCIDENT

| | | |
|--|--|-------------------|
| Aircraft Type and Registration: | Montgomerie-Bensen B8MR, G-BIPY | |
| No & Type of Engines: | 1 Rotax 532 piston engine | |
| Year of Manufacture: | 1994 | |
| Date & Time (UTC): | 11 October 2009 at 1532 hrs | |
| Location: | Near Little Rissington Airfield, Gloucestershire | |
| Type of Flight: | Training | |
| Persons on Board: | Crew - 1 | Passengers - None |
| Injuries: | Crew - 1 (Fatal) | Passengers - N/A |
| Nature of Damage: | Aircraft destroyed | |
| Commander's Licence: | National Private Pilot's Licence | |
| Commander's Age: | 64 years | |
| Commander's Flying Experience: | 10,000+ hours (of which 14 were in autogyros) Last 90 days - 13 hours Last 28 days - 4 hours | |
| Information Source: | AAIB Field Investigation | |

Synopsis

A student autogyro pilot was carrying out his first solo circuits. On the base leg of his second circuit, there was a loss of control and the aircraft fell to the ground. No evidence was found of any pre-existing aircraft defects and the reason for the loss of control was not determined.

History of the flight

On the day preceding the accident, the student pilot had carried out three one-hour sessions of solo training, consisting of wheel balancing and short hops along the runway under the supervision of his instructor. At the end of the third session he asked his instructor if he considered that he was ready to fly solo in the circuit. The instructor replied that, all being well, he could probably go solo the next day, a Sunday.

The following morning, the weather was not suitable for flying but by 1400 hrs the weather had improved and the instructor told the student that if he was able to complete a successful session of practice engine failures then he would be able to go solo. The student carried out a number of practice engine failures along Runway 22 and the instructor was satisfied with what he saw. Accordingly, he decided to send the student on his first solo circuit. Before doing so, he gave him a pre-solo briefing, advising him about the circuit area, local noise sensitive areas and that the airspeed should be kept to a maximum of 50 kt.

The instructor observed the flight from within his car, which was positioned close to the runway. There were

two other people in the car with him, one of whom also witnessed the accident. The instructor watched the pilot take off and carry out a successful solo circuit. On completion of the landing the pilot applied power and took off again for a second circuit. This surprised the instructor somewhat because he was expecting the pilot to fly just one circuit, although he had not specifically briefed him to do so.

The instructor became concerned when, on the second circuit, he saw the aircraft fly beyond the point on the base leg where he would expect it to start a descent. He saw it continue on, through the extended centreline of the runway, towards a noise sensitive area. He called the pilot on the radio and advised him that he was going in the wrong direction. There was no answer from the pilot but at that point the instructor saw the autogyro start to turn and enter a sudden and steep descent, pitching nose down and dropping about 100 ft. It appeared to recover partly but then fell out of control and the instructor realised that it must have crashed off the airfield. He, and several others from the airfield, went to search for the aircraft but were unable to locate it.

A local resident had seen and heard the autogyro flying towards his house. When it was about a third of a mile away (500 m) he saw it descend out of control; he described seeing it tumbling and heard the engine note increase slightly. He ran to his vehicle and drove across fields to where he thought the autogyro had come down. After an extensive search of some 30 minutes he drove down the side of a field and came across the wreckage in long grass. It was apparent that the pilot had not survived the accident and the witness directed the emergency services towards the site.

Pilot information

The pilot was a retired professional pilot, having flown large jet aircraft for most of his working life. Since his retirement in 1999 he had maintained a Private Pilot's Licence, flying a few hours each year, mostly on a Wilga light fixed wing aircraft. His last recorded flight in a fixed wing aircraft was in August 2008. During 2008 he also had three flights in two-seat autogyros and began a course of instruction in April 2009 on the MT-03 autogyro. The pilot completed about 10 hours of training on the MT-03; then in July 2009 he started training on single seat Montgomerie-Bensen autogyros.

The pilot had a valid medical declaration issued by his General Practitioner and appeared in good health during the weekend of the accident.

Pathological information

An autopsy determined that the pilot had died from severe multiple injuries as a result of non-survivable impact forces. He had a long medical history of episodes of irregular heart beat, caused by an electrical abnormality. If he had suffered an episode in flight it would have had the potential to cause distraction or incapacitation but it would not have created any anatomical changes which would be evident during an autopsy. Thus, there was no way of determining whether or not this occurred.

Meteorological information

The weather conditions on the morning of the accident were not suitable for autogyro flying training; there had been low cloud, rain and gusty wind conditions. However, at about 1400 hrs the weather cleared and for a while conditions were good, being described as clear and calm with light westerly winds. As the afternoon progressed, the wind strength increased.

An aftercast from the Met Office indicated that a partly unstable north to north-westerly flow covered the Little Rissington area at 1530 hrs on 11 October 2009. At 1500 hrs the automated weather report for Little Rissington recorded a surface wind from 290° at 5 kt, temperature 15°C, dewpoint 14°C, visibility 35 km, scattered cloud at 5,000 ft and a QNH pressure of 1013 hPa. By 1600 hrs the wind had increased to 10 kt and the cloud had lowered to a height of 1,400 ft. A satellite image at 1530 hrs showed a cluster of convective cloud immediately to the north of the airfield and it was considered that these conditions could have given rise to turbulence in the circuit.

Examination of the wreckage

The aircraft was found lying in long grass at the edge of a field approximately 250 m from the north-eastern boundary of the aerodrome. The main portion of the wreckage was coincident with the point of impact but pieces of the propeller blades were found along a line, on a bearing of 095°(M), up to 102 m from the main wreckage. Fuel was present throughout the aircraft's fuel system but, due to the disruption, only a small quantity remained. Any residual fuel was recovered and from visual inspection it appeared to be mixed with lubricating oil, as expected. There was a strong smell of fuel reported at the site immediately after the accident.

Examination of the ground markings and the aircraft confirmed that it had struck the surface, inverted, in a near vertical descent. The main rotor had been revolving but it was not possible to assess the rotational speed. Both main rotor blades had impact marks on their trailing edge, 69 cm from the centre of the rotor mast, and all three blades of the propeller showed evidence of strike marks and splintering. The fixed horizontal element of the empennage, variously called

a stone-guard or a stabiliser, was not fitted to the aircraft and was later found in the boot of the pilot's car.

The wreckage was removed from the site and taken to the AAIB facilities for detailed examination.

Detailed examination

The aircraft was examined and no evidence of pre-impact failure of the structure or flying controls was found. The engine had suffered some disruption and was removed from the airframe and partially disassembled for inspection. This examination did not identify any evidence of pre-impact failure. The throttle mechanism was checked and was found to operate freely and smoothly throughout its range. The calibration of the ASI was assessed using a test set and the instrument was found to be indicating accurately.

Aircraft information

This Montgomerie-Bensen B8MR was a single-seat open-framed autogyro powered by a Rotax 582 two-stroke twin-piston engine driving a three-bladed fixed pitch pusher propeller of wooden construction.

The primary structure consisted of a keel beam with a rotor mast attached. The pilot's seat, which incorporated the fuel tank, was fitted forward of the mast. A small binnacle containing the flight and engine instruments was mounted in front of the pilot. The engine was mounted behind the mast. An empennage, consisting of a vertical fin and rudder and a fixed horizontal element, was attached to the rear of the keel. This particular aircraft was fitted with an optional extended rotor mast to allow a larger propeller to be fitted.

Lift is provided by a two-bladed aluminium rotor driven by autorotative forces generated by airflow passing up through the rotor blades; it can be pre-spun

before takeoff by a flexible shaft powered by the engine.

Flight control is by means of a control stick, connected through a rod and bellcrank system to mechanisms mounted at the top of the rotor mast that alter the pitch and roll angle of the rotor disc, and by pedals operating the rudder. Unlike a helicopter, the collective pitch of the rotor blades cannot be changed. A hand-operated throttle lever, mounted to the left of the pilot's seat, controls engine power.

This type of autogyro has a thrust line above the centre of gravity and, when power is applied, the aircraft has a tendency to pitch nose-down. In normal flight this is countered by the lift or rotor thrust developed by the main rotor blades. In certain circumstances, such as a sudden application of power, too much forward control stick input, pilot induced oscillation (PIO), turbulence or excess airspeed, this high thrust line can give rise to a Power Push Over (PPO). A PPO occurs when the rotor is unloaded, causing the rotor speed to decay and the autogyro to pitch forward under the influence of the propeller thrust. This will rapidly become irreversible, and lead to the aircraft 'tumbling', unless immediate corrections are made by the pilot. The training for recovery from any unusual attitude is to close the throttle, centre the control stick and allow the aircraft to settle into autorotation before attempting any control inputs. If the pilot were to make a large aft cyclic input in an attempt to correct the attitude, the blades may strike the propeller or tail surfaces.

The CAA issued a Mandatory Permit Directive (MPD No: 2005-008) on 24 August 2005 which placed limitations on all single-seat gyroplanes. The MPD states:

'CAA flight testing of some Bensen derivative gyroplanes has found that poor handling characteristics exist if such machines have a thrustline / CG offset that exceeds +/- 2 inches. The CAA considers that inexperienced gyroplane pilots are at risk due to these handling characteristics and that this combination constitutes an unsafe condition.'

A number of limitations were imposed by this MPD and the Light Aircraft Association (LAA) incorporated all of these limitations into the Operating Limitations of the Permit to Fly for this type of aircraft, thereby ensuring compliance with this MPD. The thrustline / CG offset for G-BIPY had not been measured, so remains an unknown quantity in the accident.

The MPD also specified wind limitations, which were included in Operating Limitations of the Permit to Fly. Flight was prohibited when the surface wind, including gusts, exceeded 15 kt (17 mph) or when the surface wind gust spread exceeded 10 kt (12 mph).

The pilot purchased the aircraft in September 2009 with a view to using it to complete his autogyro flying training. Previously, it had been subject to an extensive overhaul in June 2009, prior to the renewal of its Permit to Fly. A new¹ engine was then installed in September 2009, at the pilot's request.

On the morning of the accident flight the pilot installed a modification to add an 'O' ring to the jet needle in each carburettor. This was an approved modification and was completed under the supervision of a LAA Inspector.

Footnote

¹ Although the engine was unused it was originally supplied by the UK distributor in August 1989. It was intended for use in another aircraft that was not completed and had been in storage until installation on this aircraft.

Witnesses also reported seeing the pilot removing the aircraft's stone-guard/stabiliser that morning, although there was no record of this.

Accident history

The safety record of autogyros was discussed following an accident to Bensen B8MR(modified), registration G-BIGU, in AAIB Bulletin 9/2004 and in the re-issued Bulletin 6/2007. This identified that all but one of the pilots involved in fatal accidents had less than 50 hours on autogyros and a large proportion of them held fixed wing or helicopter licences. It was also noted that longitudinal instability was cited as a primary cause in half of the fatal accidents over a three year period in the USA.

In the 19 years from 1990 to 2009 there have been 15 fatal autogyro accidents in the United Kingdom, the majority of which have been in single seat aircraft. The CAA *Aviation Safety Review – 2008*, Civil Aviation Publication (CAP) 780, provides a comparison of fatal accidents rates between autogyros, microlights and gliders. The rate for autogyros peaked in 2002 and has declined slowly since then, however; the rate per flying hour for autogyros is approximately ten times that for gliders and microlight aircraft. This relatively high rate, together with several AAIB Safety Recommendations, led to a number of actions being included in the CAA Safety Plan 2006. These actions included research into the aerodynamic characteristics of autogyros and changes to pilot and instructor licensing and training. The CAA Safety Plan identified several risk factors that may have relevance to this accident:

'Lack of experience and of recency were both factors identified in the analysis of gyroplane accidents'

'Extensive fixed wing flying experience has also been cited as a contributory factor in some gyroplane accidents'

Analysis

Engineering conclusions

The aircraft appeared to be in good condition and work conducted during the recent overhaul was to the required standard. The Certificate of Validity of the Permit to Fly was in date and no evidence of pre-impact failure was found within the structure, engine or control linkages.

It appears that the pilot had removed the stone guard/stabiliser during the morning prior to the accident flight, without recording the work or first clearing it with the Light Aircraft Association (LAA). However, based on written flight test reports and anecdotal evidence, its removal would not have had a measurable effect on the aircraft's handling characteristics. The pilot had previously flown his instructor's aircraft which also did not have a stone guard/stabiliser fitted.

Damage to the main rotor and the extended trail of propeller fragments indicated that the propeller contacted the main rotor sometime before the aircraft struck the ground. The nature of the damage to the propeller also showed that the engine was delivering power when this happened. The co-location of the main wreckage with the point of impact was symptomatic of a near-vertical final descent with little or no forward speed.

Operational

The aircraft first deviated from its expected flightpath when the descent was not initiated on the base leg of the second circuit. It was not possible to ascertain why this occurred but some explanations were considered. The pilot may have been distracted or partly incapacitated,

he may have had difficulty controlling the aircraft in turbulence or he may have mis-identified his position in the circuit pattern and, when he realised, made a sudden control input.

The pilot had a pre-existing medical condition that could have led to his being distracted or temporarily incapacitated. Autogyros can only fly for a short time ‘hands off’ or without a pilot input so, in such a situation, a loss of control would develop rapidly.

The weather conditions when the pilot started flying in the afternoon were calm and good. There were some indications from the aftercast that the wind speed increased with time and that there may have been some associated turbulence in the circuit around the time of the accident. Turbulence increases the likelihood of a displacement to the intended flightpath which is undesirable, particularly for an inexperienced student pilot.

The instructor made a radio call in an attempt to contact the pilot and it appeared that this led to a response from

the pilot, since the aircraft started to turn and descend shortly afterwards. However, this could have been coincidental.

This autogyro has very light and sensitive controls, so, if the pilot made a sudden or instinctive input in the wrong direction or too strongly, it could have led to a loss of control. He had significant experience on larger types of aircraft which used different control systems, therefore, it is possible that he reacted to an event with an instinctive but inappropriate control input.

The loss of control, as observed by the witnesses, suggests that a problem developed with longitudinal stability. The aircraft was reported as pitching steeply nose-down and “tumbling”, which is a characteristic seen as a result of a PPO.

In summary, there are several different circumstances which may have contributed to this accident but it was not possible to draw a firm conclusion from the available evidence. There was a loss of control of the autogyro but the reason for it could not be determined.

ACCIDENT

| | | |
|--|---|-------------------|
| Aircraft Type and Registration: | P&M Aviation Ltd Flight Design CTSW, G-VINH | |
| No & Type of Engines: | 1 Rotax 912ULS piston engine | |
| Year of Manufacture: | 2006 | |
| Date & Time (UTC): | 12 August 2009 at 1550 hrs | |
| Location: | Caird Park Golf Course, Dundee | |
| Type of Flight: | Private | |
| Persons on Board: | Crew - 1 | Passengers - None |
| Injuries: | Crew - 1 (Minor) | Passengers - N/A |
| Nature of Damage: | Aircraft destroyed | |
| Commander's Licence: | National Private Pilot's Licence | |
| Commander's Age: | 63 years | |
| Commander's Flying Experience: | 136 hours (of which most were on type) ¹ Last 90 days - 20 hours Last 28 days - 13 hours | |
| Information Source: | AAIB Field Investigation | |

Synopsis

The pilot made a forced landing in a tree after the engine stopped near Dundee. The investigation identified flight planning as a contributory factor. One Safety Recommendation is made.

History of the flight

The pilot planned to fly from Barrow (Walney Island) Airfield to Kinloss, a distance of 212 nm. During a pre-flight check, he judged that the left and right tanks contained 25 litres and 15 litres of fuel, respectively. He calculated a maximum flying time of 3 hr 20 mins based on a fuel consumption of 12 litres per hour, which he had assessed as the "long-term average" for this aircraft. In his planning he considered Dundee Airport as an alternate.

The aircraft began taxiing at 1346 hrs and took off at 1352 hrs, climbing initially to an altitude of between 1,600 ft and 2,000 ft. At 1425 hrs the aircraft commenced a further climb to 7,500 ft. This took 10 minutes and the pilot used "80% power". At 1435 hrs the aircraft made a further climb to 8,700 ft. During this climb the aircraft entered Class A airspace at FL85 over Eskdalemuir, exiting into Class D airspace as it crossed into the Scottish TMA approximately 10 nm further north (see Figure 1).

Footnote

¹ The pilot was not able to reconstruct a complete record of his flying experience



Figure 1

The aircraft's GPS track

©Crown copyright. All rights reserved Department for Transport 100020237 [2010]

At 1440 hrs the pilot contacted the Scottish Area Control Centre (SACC), advising his intended route and his wish to climb to 9,000 ft to remain clear of cloud. The controller cleared the aircraft on track to Kinloss and asked the pilot to advise her before making any “big turns” because the aircraft was in the “TMA environment” and potentially in conflict with aircraft under her control bound for Edinburgh.

As the aircraft approached the lateral limits of the Edinburgh Control Area (CTA)² from the south, the pilot requested and was cleared to make a further climb to 10,000 ft in order to remain clear of cloud. Five minutes later the pilot reported ‘CLOUD AHEAD THE BASE LOOKS QUITE HIGH COULD I HAVE PERMISSION TO DESCEND 5,000 FT SAME HEADING’. Initially, SACC cleared the aircraft to FL70, due to traffic in the CTA, and instructed the pilot to contact Edinburgh Radar. The pilot read back the correct frequency but had not made contact with Edinburgh ATC before the aircraft entered the CTA. It exited the CTA northbound at an altitude of approximately 4,500 ft and continued to descend to 2,000 ft.

Later, as the aircraft crossed the Firth of Tay, having climbed again to a height of approximately 4,500 ft, the pilot noted that the right wing fuel tank was empty and that only 10 litres remained in the left tank. Judging that he had insufficient fuel to continue the flight he turned the aircraft south towards Dundee Airport, where he was instructed to join for Runway 27 via the reporting point at Broughty Castle. He stated that at that point there was at least 5 litres of fuel remaining in the left tank. At 1548 hrs the pilot advised Dundee ATC that the aircraft had run out of fuel.

Footnote

² The Edinburgh CTA is a column of airspace 40 nm in diameter centred on Edinburgh Airport and extending from the surface to an altitude of 6,000 ft. It lies within the Scottish TMA and is classified as Class D airspace.

The aircraft was now heading south-east over fields on the northern edge of Dundee, approximately 2 nm northeast of the airport. The pilot judged that he would be unable to land clear of the built up area on his present track and turned north in an attempt to find more open ground. He reported that initially the most favourable landing area appeared to be nearby playing fields but, noticing that these were occupied by children, he turned towards an adjacent golf course. However, the fairways also appeared congested, so the pilot decided to land in a tree. The impact resulted in substantial damage to the aircraft, which remained in the tree.

The pilot, who sustained minor injuries, was removed from the aircraft with the assistance of the emergency services and taken to hospital.

Flight in controlled airspace

The pilot held a National Private Pilot’s Licence which does not permit flight under instrument flight rules and therefore does not permit flight in Class A airspace. There is no record of the pilot holding a valid flight radio telephony operator’s licence at the time of the flight.

Flight in Class D airspace requires a clearance either via radio telephony or by prior arrangement. The commander of an aircraft flying in an aerodrome traffic zone is required to obtain permission to do so from the associated ATC unit and to maintain a continuous watch for instructions (though not necessarily by radio³). The Edinburgh ATC unit reported entry of the aircraft into the CTA without clearance as an infringement.

Footnote

³ Rule 45 of the rules of the air, Schedule 1 Section 7 of Civil Aviation Publication (CAP) 393 – ‘The Air Navigation Order’ refers.

Recorded information

An AvMap EKP-IV GPS unit and a Bräuniger Alpha multi-function display (MFD) were recovered from the crash site; both contained recorded data for the accident flight.

AvMap EKP-IV GPS

The GPS unit had a complete log of the accident flight starting at 1346:03 hrs at Walney Airfield, Barrow-on-Furness, and ending at 1548:31 hrs at the Caird Park golf course, Dundee. The recorded track included altitude information and is presented at Figure 1. The highest altitude the aircraft reached was 9,935 ft amsl, at 1504:24 hrs, when it was approximately 15 nm south of Edinburgh.

Altitude and groundspeed, averaged between consecutive points, are plotted in Figure 2. This shows a descent from 9,935 ft to 1,663 ft amsl, as the aircraft crossed the A91 north of Glenrothes, before it climbed again.

The final descent was at a rate of approximately 900 ft/min, reducing to 600 ft/min as the aircraft flew a descending turn, clockwise, through 270° (see Figure 3). The aircraft continued descending at about this rate until the final recorded GPS position, which placed the aircraft at 340 ft amsl (110 ft agl), close to the accident site.

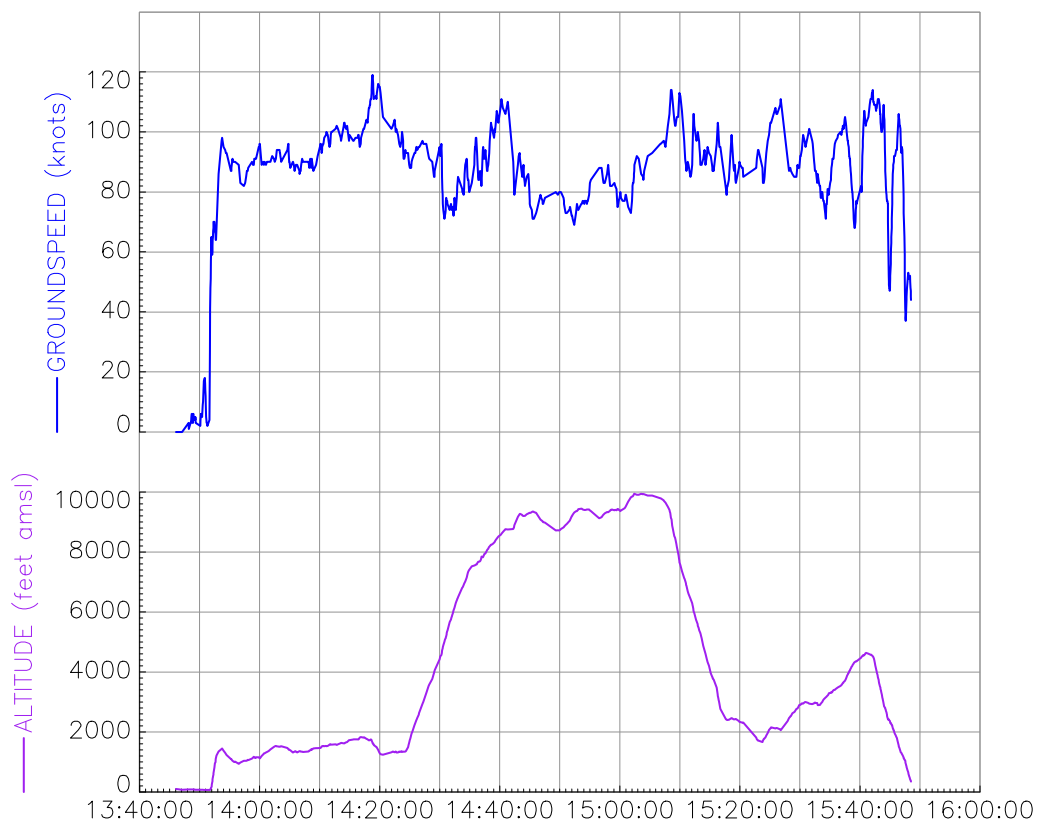

Figure 2

The aircraft's altitude and groundspeed



Figure 3

Image of the aircraft's GPS track just prior to the accident

Bräuniger Alpha MFD

This unit consisted of a multi-function display instrument pod with a memory module that recorded a number of engine parameters for the accident flight and the preceding 23 flights. The unit did not provide a continuous record for the duration of each flight but recorded maximum values, which highlighted any exceedences. In general, these were of little value, as no calibration data or limits were provided. However, it was apparent from the downloaded data that the maximum altitude achieved during the accident flight was 10,013 ft (at 1013mb), the maximum indicated

airspeed was 120 kts, the takeoff (at the point where 50 km/hr was exceeded) was at 1350 hrs, with flight time and engine running time being 1hr 57 mins and 2 hrs 4 mins, respectively. There were two exhaust gas temperature records, EGT 1 and EGT 2, with recorded maxima of 113°C and 804°C. In addition, there were two cylinder head temperatures, CHT 1 and CHT 2 which were reported as “not measured”. Reference to the engine manufacturer’s Installation Manual revealed that the nominal EGT is 800°C, with a maximum of 850°C (880°C at take off power). Maximum CHT is specified as 135°C.

The disparate values of EGT1 and EGT2, together with the absence of any CHT record, suggested that there may have been a wiring fault associated with the instrument pod and memory module. The numerical values indicated that a representative CHT value (113°C) may have been recorded into the EGT1 data location. The EGT2 value of 804°C compared favourably with the specified maximum of 850°C.

Flight planning

The pilot stated that during flight planning he assumed an average fuel consumption of 12 litres per hour, based on records of previous flights. In its own literature, the aircraft manufacturer states that fuel consumption of the 912 ULS engine in this installation is 18.5 litres per hour at 75% cruise power and 25 litres per hour at maximum continuous power (5,500 rpm). The same document states that the cruise speed at 75% power is 112 kt.

The manufacturer indicated that lower fuel consumption can be achieved at lower power settings, which will result in lower cruise speeds. The 'Performance & engine data' section of the CTSW Operators Manual states that cruising fuel consumption ranges from 10 to 14 litres per hour. It concludes with the warning:

'Fuel consumption figures are guide figures only. Always fly with a minimum of 1 hours reserve fuel.'

Kinloss is 212 nm from Barrow on a bearing of 357°(M).

Meteorological information

Forecasts available to the pilot for flight planning purposes indicated average winds along the route of 25 kt from 280°(T) at 2,000 ft, increasing to 35 kt from 300°(T) at 10,000 ft. This suggests an average headwind

component of approximately 11 kt on the direct track between Barrow and Kinloss.

Aircraft and fuel system description

Type approval for this aircraft in the United Kingdom was obtained by P&M Aviation, who submitted the design to the UK CAA against British Civil Aircraft Requirements (BCARs) Section 'S', although parts of the Joint Airworthiness Requirements - Very Light Aircraft (JAR-VLA) were also used. Certification in other countries was achieved using various design codes. P&M are responsible for modifications on aircraft with UK Permits to Fly, with Flight Design retaining overall control of the design. The relevant BCAR for unusable fuel is specified in paragraph S959 as follows:

'The unusable fuel quantity for each tank must be established as not less than that quantity at which the first evidence of malfunctioning occurs under the most adverse fuel feed conditions occurring during take-off, climb, approach and landing involving that tank. It shall not be greater than 5% of the tank's capacity.'

The CTSW is a high-wing aircraft equipped with integral wing tanks, with the fuel stored in the volume ahead of the main spar. Each 65 litre capacity tank extends from the wing root to approximately mid span. A circular plug in each root rib incorporates a fuel contents sight tube and the fuel off-take tube (see photographs at Figure 4). The latter comprises an inlet strainer assembly attached to a short length of rigid tube that serves to hold the inlet strainer close to the fuel tank floor at the aft inboard corner. The wings have a 1.5° dihedral angle, which, in balanced flight, would assist in keeping the fuel towards the inboard ends of the tanks. Each tank contains a single baffle located approximately 0.45 m from the wing root; its purpose is to limit the span-wise fuel surge that occurs



Fuel off-take tube



View of left tank fuel contents sight tube and gauge

Figure 4

Views of fuel tank off-take, fuel contents sight tube and gauge

as a result of aircraft motion. The baffle is essentially an internal rib, but with a series of small holes drilled close to the tank floor, which, in conjunction with narrow slots around the edges, allow the passage of fuel. The outlets of the left and right tanks are joined together in the fuselage, immediately upstream of a simple ON/OFF fuel selector. Thus, an ON selection will result in fuel

being drawn simultaneously from both tanks. Although the high-wing configuration provides a gravity feed system, the aircraft is additionally equipped with an engine driven fuel pump.

There is no sump or depression in the tank that would tend to keep the end of the fuel off-take tube immersed

in fuel; neither is there a weir, nor a flap valve within the baffle, that would assist in maintaining a quantity of fuel within the inboard section of the tank.

The CTSW was developed from the CT2K, which has an identical fuel system, although UK registered aircraft were originally required by the CAA to have the fuel selectable from either the left or right tank only, not both. In July 2007, following a number of engine failure incidents, the manufacturer issued Service Bulletin (SB) CT125, which incorporated Modification No M186. This was mandated by the CAA. The SB modified the fuel system so that the left and right tanks were interconnected and fuel was fed from both tanks simultaneously, in the same manner as foreign registered CT2Ks and the CTSW. Information in the SB noted that:

'after the modification, the fuel should feed reasonably evenly from both tanks. Imbalance in flight can be corrected by flying with a little sideslip for a while.'

Additional guidance material included the caution that:

'The aircraft should be parked wings reasonably level, otherwise the fuel will cross feed to the low tank and may be lost through the tank vent.'

The latest development of the CT family is the CTSL, of which there are none currently on the UK register. The manufacturer stated that although the fuel system is essentially the same as for earlier variants, the fuel tank baffles incorporate flap valves.

Examination of the aircraft

Agents acting for the insurance company that recovered the aircraft reported that the right fuel tank was intact but empty, with "several pints" pouring out of the

left tank during the recovery. The pilot subsequently supplied photographs of the site that were taken several days after the accident; these showed characteristic staining of the vegetation on and around the tree in which the aircraft had come to rest. It was impossible to assess the quantity of fuel required to cause the observed staining; however, it was considered to be broadly consistent with the pilot's observation of approximately 5 litres in the left tank shortly before the engine lost power.

The aircraft wreckage was taken to the AAIB's facility at Farnborough for examination. The fuel lines were found free from obstructions and there was no evidence of pre-impact engine component failure. An internal inspection of the cylinders revealed them to be in good condition, with no evidence of lubrication failure. A small quantity of fuel, approximately 1 cc, was found in the float chamber of one of the detached carburettors. This was analysed and found to conform to the specification of motor gasoline containing 4% ethanol.

In view of the circumstances of the accident, while focussing on the fuel system, the investigation paid particular attention to the tank installation. A simple test was conducted on one of the tanks.

Fuel tank tests

The right wing of the aircraft, which had remained relatively intact following the accident, was placed on trestles at an approximate zero angle of incidence and 1° dihedral. Having ensured that the tank was completely empty, water was then introduced, one litre at a time. After 5 litres had been added, a few drops were seen to emerge from the fuel feed tube, with the water level just visible at the bottom of the sight tube. A sustained flow could be achieved only when the wing tip was raised to an angle of around 8°, at which point the water level was

almost halfway up the sight tube. The late onset of flow was attributed to the fact that, with reference to Figure 4, the fuel feed tube is positioned approximately 15 mm above the sight tube lower fixture, meaning that the fuel had a small gradient to climb from the inlet strainer assembly in the bottom of the tank. Once a siphon was established, flow could be maintained at lower dihedral angles and continued to the point at which the inlet strainer in the tank became uncovered. At this point slightly more than 0.5 litre remained in the tank.

Similar tests conducted by the aircraft manufacturer indicated that, with the aircraft on level ground at zero angle of incidence (cruise attitude), fuel feed continued until 0.5 litres remained in the tank, which represented the unusable fuel. This equated to 0.7% of the tank volume of 65 litres, compared with the 'not more than 5% of the tank volume' requirement in BCAR S959. However, when the test was repeated with the aircraft at a 1° nose-down attitude with a 2° adverse sideslip, the unusable fuel was found to be 3.6 litres, although it should be noted that S959 does not cover continuous sideslip.

The manufacturer also described an airborne test in which an aircraft was flown until the engine became starved of fuel, before gliding to a landing. Measurement of the remaining fuel showed that the unusable quantity was very small. Additional tests were conducted, with the aircraft on the ground, in which the engine was run from a small quantity of fuel in one tank, the aircraft tilted so that the fuel off-take was uncovered, following which the engine stopped. After tilting the aircraft back to a level attitude, it was possible to restart the engine; this showed that the engine driven pump was effective in assisting to restore the siphon. The manufacture now requires a production test in which the restart time must be less than 60 seconds.

Discussion

Operational issues

Flight planning

The pilot estimated that the aircraft's maximum endurance without reserves was 3 hours 20 minutes, based on his assessment of average fuel consumption. The corresponding estimate based on the aircraft manufacturer's literature was 2 hours 9 mins. The flight time from Barrow to Kinloss would have been 1 hour 53 mins in still air, at the manufacturer's stated cruise speed of 112 kt, or 2 hours 6 mins allowing for the forecast headwind component of approximately 11 kt. The average ground speed was in fact approximately 90 kt, at which the flight to Kinloss would have taken 2 hours 21 mins.

The accident flight time of 1 hour and 57 mins was preceded by 6 minutes of ground running and included at least 10 minutes in the climb. There is no record of the actual power setting used during each phase of the flight. On previous flights, during which the aircraft cruised at or below 3,000 ft, the peak recorded engine speed was approximately 4,800 rpm, which corresponds to 75% cruise power, whereas on the accident flight the peak recorded engine speed was 5,180 rpm. This suggests that power settings greater than 75% were used on this flight. Also, the pilot stated that the climb to 7,000 ft was conducted at "80% power". It follows that actual average fuel consumption was greater than cruise consumption because the extra fuel used during the climb would not be entirely offset by any reduction in power during the subsequent descents. The average fuel consumption assumed by the pilot was insufficient to account for operational realities.

Safety Sense Leaflet 1 – '*Good airmanship guide*', published by the CAA, provides guidance on flight planning. It states, in part:

'Always plan to land by the time the tank(s) are down to the greater of ¼ tank or 45 minutes cruise flight, but don't rely solely on gauge(s) which may be unreliable. Remember, headwinds may be stronger than forecast and frequent use of carb heat will reduce range.'

And,

'Don't assume you can achieve the Handbook/Manual fuel consumption. As a rule of thumb, due to service and wear, expect to use 20% more fuel than the "book" figures.'

Flight in controlled airspace

Infringement of controlled airspace and flight within the Edinburgh ATZ without permission did not directly affect the outcome.

Engineering issues

The pilot reported that, shortly before the engine lost power, he had observed zero fuel indication in the right tank and approximately 5 litres in the left. It is apparent from Figure 4 that the 5 litres represents a low value, and it is noteworthy that it is written in red on the adjacent fuel contents scale. In addition, the location of the sight tube relative to the scale would be prone to parallax error. However, any such error is likely to be insignificant compared with the inherent inaccuracy arising from the tank geometry, the width to length ratio of which could give rise to considerable span-wise movement of fuel in response to lateral accelerations. Thus an accurate reading, or at least one with the least amount of error, would only be achieved with the aircraft in a level attitude and in balanced flight in smooth conditions.

In a fuel system such as this, where the fuel tanks are interconnected, there will be a tendency for fuel to transfer

from one tank to another in the event that the aircraft is flown out of balance, ie in a condition of sideslip. This could be exacerbated by any difference in the fuel feed rates between the two tanks. In such a situation, the pilot is advised by the manufacturer to correct any imbalance by flying with an amount of sideslip for a period.

As the fuel quantity reduces, any sideslip in excess of the 1.5° dihedral would result in significant outboard migration of fuel in the lower wing, although this would be compensated by inboard fuel movement in the opposite wing. There could come a point, if this state continued, where the fuel off-take in one tank would be uncovered, thus breaking the siphon, although fuel feed to the engine should be maintained from the opposite side. A situation could thus arise whereby the fuel flow in one tank would be interrupted, with an attendant possibility of air being drawn into the system. A similar situation could result from a nose-down aircraft attitude, since this would cause the fuel to move forward, away from the fuel off-take.

Conclusions

The reported circumstances of the accident indicate that the engine became starved of fuel. The nature of the tank design is not conducive to accurate gauging, with any sustained sideslip or nose-down attitude effectively generating quantities of unusable fuel in excess of the 0.5 litres stated by the aircraft manufacturer. In fact the manufacturer's own tests, conducted with the aircraft on the ground, indicated a significant increase in the unusable fuel quantity when the aircraft attitude changed from the straight and level. The manufacturer additionally noted that it was possible to restart the engine following temporary fuel starvation; however, this might not be a practical procedure for pilots in the course of a normal flight and, moreover, would not comply with BCAR S959, which refers to the **first**

evidence of malfunctioning. The BCAR allows up to 5% of the tank volume to be unusable, which equates to 3.25 litres. This would seem to represent a more realistic figure in actual flying conditions, despite the manufacturer having conducted flight tests in which lower quantities were demonstrated.

On this flight, the headwind and vertical profile resulted in it taking longer than planned. Nevertheless, during the latter stages the pilot was convinced, from the indication of left fuel tank contents, that he was not about to run out of fuel.

Safety Recommendation 2010-045

It is recommended that Flight Design GmbH, together with P&M Aviation, revise their assessment of the unusable fuel in the CTSW aircraft.

Additional safety action

Following this accident, P&M Aviation declared their intention to publish a Service Letter which will explain the effects of aircraft attitude and turbulence on fuel feed at low fuel levels. In addition, it will point out that the minimum quantity that the fuel sight gauge will indicate is 3 litres. Finally, a placard will be required to be fitted to the aircraft advising the pilot that he or she must ensure that at least 1 cm of fuel is visible on both fuel contents sight gauges at all times.

ACCIDENT

| | | |
|--|---|-------------------|
| Aircraft Type and Registration: | Rotorsport UK MT-03 gyroplane, G-CFCG | |
| No & Type of Engines: | 1 Rotax 912ULS piston engine | |
| Year of Manufacture: | 2008 | |
| Date & Time (UTC): | 6 March 2010 at 1435 hrs | |
| Location: | Rufforth Airfield East, York | |
| Type of Flight: | Training | |
| Persons on Board: | Crew - 1 | Passengers - None |
| Injuries: | Crew - 1 (Minor) | Passengers - N/A |
| Nature of Damage: | Bent chassis, control rods, damaged nacelle | |
| Commander's Licence: | Student | |
| Commander's Age: | 43 years | |
| Commander's Flying Experience: | 49 hours (of which 49 were on type) Last 90 days - 1 hour Last 28 days - 1 hour | |
| Information Source: | Aircraft Accident Report Form submitted by the Instructor | |

The student had already completed seven successful solo circuits on Runway 14. The surface wind was from 120° at 4 to 6 kt. On the eighth circuit he initiated a glide approach from 1,000 ft. The landing was long and the round-out slightly high, causing the aircraft to lose airspeed. It bounced after touchdown and began to roll to the right. The student applied power to go around, but then lost control of the aircraft. It yawed left and rolled onto its right side, causing the rotors to strike the

runway, and slid along the runway on its right side for approximately 12 m. He shut down the engine before vacating the aircraft. The student had not flown for several months and had completed a dual check with the instructor earlier on the day of the accident. This had included glide approaches and crosswind takeoff and landing practice in light winds. He was judged to be sufficiently accomplished to fly solo.

ACCIDENT

| | | |
|--|--|-------------------|
| Aircraft Type and Registration: | Savannah VG Jabiru(1) microlight, G-CFSX | |
| No & Type of Engines: | 1 Jabiru Aircraft PTY 2200 piston engine | |
| Year of Manufacture: | 2009 | |
| Date & Time (UTC): | 31 May 2010 at 1900 hrs | |
| Location: | Private airstrip, Idsworth, Hampshire | |
| Type of Flight: | Private | |
| Persons on Board: | Crew - 1 | Passengers - 1 |
| Injuries: | Crew - None | Passengers - None |
| Nature of Damage: | Propeller, nosewheel spindle broken, distortion to cockpit area and most parts of the airframe | |
| Commander's Licence: | National Private Pilot's Licence | |
| Commander's Age: | 55 years | |
| Commander's Flying Experience: | 97 hours (of which 26 were on type) Last 90 days - 4 hours Last 28 days - 2 hours | |
| Information Source: | Aircraft Accident Report Form submitted by the pilot | |

Following an uneventful flight, the pilot's first attempt to land was made slightly too fast and was aborted because the aircraft floated too far down Runway 36, which had a 1% downslope. The reported wind was 360° between 2 and 3 kt. The second approach was made at the recommended speed and shallower than the first. Whilst on final approach and just short of the grass strip, the aircraft encountered some sink. In order to clear the boundary fence at the start of the strip, the pilot

pulled back on the control column and added power. The aircraft cleared the fence but stalled immediately afterwards, landing heavily on the nose gear before pitching over onto its back, causing damage to the nose gear, propeller and most of the aircraft's structure. The pilot and passenger, both wearing full harnesses, were uninjured. The pilot's assessment of the cause of the accident was that he too low on the approach and reacted too slowly in applying power to arrest the descent rate.

ACCIDENT

| | | |
|--|--|--------------------------|
| Aircraft Type and Registration: | Sky 260-24 hot air balloon, G-KTKT | |
| No & Type of Engines: | Triple burner | |
| Year of Manufacture: | 1998 | |
| Date & Time (UTC): | 13 August 2009 at 1950 hrs | |
| Location: | Near Brodsworth Hall, Doncaster, South Yorkshire | |
| Type of Flight: | Commercial Air Transport (Passenger) | |
| Persons on Board: | Crew - 1 | Passengers - 10 |
| Injuries: | Crew - None | Passengers - 1 (Serious) |
| Nature of Damage: | None | |
| Commander's Licence: | Commercial Pilot's Licence | |
| Commander's Age: | 65 years | |
| Commander's Flying Experience: | More than 2,000 hours (of which 1,000+ were on type) Last 90 days - 10 hours Last 28 days - 10 hours | |
| Information Source: | AAIB Field Investigation | |

Synopsis

The pilot was landing the balloon in a field of stubble in which there were a number of large rectangular straw bales. The balloon basket bounced and dragged on landing before coming to a stop against one of the bales. During the landing a female passenger sustained serious injuries.

History of the flight

The pilot had arranged for the flight to depart from The Dome Leisure Centre, a site within the town of Doncaster. The weather conditions at the site were fine and calm and the passengers were briefed on procedures for the flight.

At 1900 hrs, the balloon took off with ten passengers and the pilot on board. The wind strength was estimated to be 4 kt and, as the flight progressed, it increased to 10 kt. After an uneventful 45 minutes, in the course of which the balloon travelled about 5 nm, the pilot initiated a descent in preparation for a landing. During the flight, the passengers were briefed on the procedures and the position to adopt for landing.

The pilot commented that there was some turbulence in the valley during the approach before the landing was carried out into a field of stubble in which there were a number of large rectangular straw bales. The balloon basket bounced about 15 ft into the air, touched down again and then dragged, at walking pace, for a distance

of some 50 m before coming to a stop against a bale. The passengers all disembarked from the balloon with the exception of one female passenger, aged 67 years, who had been injured. She was assisted out of the basket by other passengers and helped into a sitting position, leaning against the basket. While the pilot was engaged in a discussion with the farmer in whose field the balloon had landed, fellow passengers assisted the injured lady. At their request, the pilot telephoned for an ambulance and the injured passenger was taken to a local hospital where she was diagnosed with fractures to both legs.

Discussion

The passengers were required to complete forms before the flight, declaring that they were fit for the flight and advising the pilot of their weight so that a payload calculation could be completed. The basket was partitioned and each compartment, which could hold up to three people, had rope handles fitted around its sides.

According to the company's operations manual, all passengers should be briefed before a flight on normal and emergency procedures and should also be shown, and rehearse, adopting the required landing position. The manual contains the note:

'in a partitioned basket passengers should be told that they will be coming in to land backwards and will not be able to see where they are landing, knees should be bent but not so much that it ends in them sitting on the floor of the basket.'

The wind strength had increased to around 10 kt for the landing, within the flight manual limit of 15 kt. In the harvest season, a number of possible landing fields

will have bales left out in them. It is not unusual for a pilot to choose to use such a field, provided he is able to plan a touchdown path clear of any obstructions.

The passengers remarked that the flight had, overall, been smooth and the pilot considered that the landing was not excessively rough by ballooning standards. However, he also commented that "the injured lady was probably unfortunately positioned and unlucky to sustain such serious injury".

A review was carried out of records held by the AAIB of accidents to balloons engaged on Commercial Air Transport flights in the UK since 1990. This showed that there have been at least 20 balloon accidents during the period where one or more passengers has suffered a 'serious injury' as a result of what would be considered a 'normal' or 'firm' landing. A 'serious injury' is one where a fracture of a bone has occurred or a person was hospitalised. It was also noted that in a significant proportion of these reports the injured passenger was described as 'elderly'.

It is considered that, when deciding to embark on a balloon flight, a number of passengers may not be sufficiently aware of the nature of some balloon landings. Balloon landings can take place at unprepared sites and may occasionally be bumpy for the occupants, especially in higher wind conditions if the basket tips over and drags along the ground. At present, not all commercial balloon operators make passengers aware of this, either at the booking stage or prior to a flight. Also, the severity of the impact experienced by an occupant may vary according to their position in the basket.

Safety Recommendation 2010-052

Balloon landings can take place at unprepared sites and may occasionally be bumpy for the occupants, especially in higher wind conditions if the basket tips over and drags along the ground. At present, not all commercial balloon operators make passengers aware

of this, either at the booking stage or prior to a flight. Therefore, it is recommended that the Civil Aviation Authority require all commercial balloon operators to make prospective passengers aware of the varied nature of balloon landings so that they can make an informed decision as to whether or not to undertake a flight.

BULLETIN ADDENDUM

| | |
|--|---|
| AAIB File: | EW/G2008/04/07 |
| Aircraft Type and Registration: | Cessna F177RG Cardinal, G-BFPZ |
| Date & Time (UTC): | 24 April 2008 at 1611 hrs |
| Location: | Swansea Airport |
| Information Source: | Aircraft Accident Report Form submitted by the pilot, follow-up telephone inquiries, and in situ examination by the AAIB of the main landing gear downlocks |

AAIB Bulletin No 8/2008, page 90 refers

Additional information

Further to this accident, and its investigation, the same aircraft, G-BFPZ, suffered a similar accident on 29 March 2009, at Popham airfield, in Hampshire

(Ref: EW/C2009/03/04) is published in this Bulletin. In this instance, the investigation revealed a technical problem in the landing gear system.

BULLETIN CORRECTION

| | |
|--|--|
| AAIB File: | EW/G2008/10/10 |
| Aircraft Type and Registration: | Cyclone AX3/503, G-MYFZ |
| Date & Time (UTC): | 17 October 2008 at 1600 hrs |
| Location: | Chilbolton Airfield, near Stockbridge, Hampshire |
| Information Source: | Aircraft Accident Report Form |

AAIB Bulletin No 1/2009, page 34 refers

The above report was originally published in AAIB Bulletin 1/2009. However, following further investigation the report has now been reissued.

The pilot stated in his report that he had intended to practise a simulated engine failure after takeoff. However, the aircraft climbed too steeply before reaching a safe height

to conduct the procedure, the airspeed reduced rapidly and the aircraft stalled, at about 100 ft in the pilot's estimation. With insufficient height to recover fully, the aircraft landed heavily on the runway, nosewheel first. This resulted in substantial damage to the aircraft and injuries, initially classified as minor, to the occupants.

FORMAL AIRCRAFT ACCIDENT REPORTS ISSUED BY THE AIR ACCIDENTS INVESTIGATION BRANCH

2009

- | | | | |
|--------|--|--------|---|
| 1/2009 | Boeing 737-81Q, G-XLAC, Avions de Transport Regional ATR-72-202, G-BWDA, and Embraer EMB-145EU, G-EMBO at Runway 27, Bristol International Airport on 29 December 2006 and on 3 January 2007. Published January 2009. | 4/2009 | Airbus A319-111, G-EZAC near Nantes, France on 15 September 2006. Published August 2009. |
| 2/2009 | Boeing 777-222, N786UA at London Heathrow Airport on 26 February 2007. Published April 2009. | 5/2009 | BAe 146-200, EI-CZO at London City Airport on 20 February 2007. Published September 2009. |
| 3/2009 | Boeing 737-3Q8, G-THOF on approach to Runway 26 Bournemouth Airport, Hampshire on 23 September 2007. Published May 2009. | 6/2009 | Hawker Hurricane Mk XII (IIB), G-HURR 1nm north-west of Shoreham Airport, West Sussex on 15 September 2007. Published October 2009. |

2010

- | | | | |
|--------|--|--------|--|
| 1/2010 | Boeing 777-236ER, G-YMMM at London Heathrow Airport on 28 January 2008. Published February 2010. | 3/2010 | Cessna Citation 500, VP-BGE 2 nm NNE of Biggin Hill Airport on 30 March 2008. Published May 2010. |
| 2/2010 | Beech 200C Super King Air, VQ-TIU at 1 nm south-east of North Caicos Airport, Turks and Caicos Islands, British West Indies on 6 February 2007. Published May 2010. | | |

AAIB Reports are available on the Internet
<http://www.aaib.gov.uk>