



# Plasma Physics at AWE

Presented to the  
Chinese Academy of Engineering Physics,

June 2012

██████████  
Plasma Physics Group  
AWE Aldermaston  
RG7 4PR

*Acknowledgements are due to my AWE colleagues whose vuoils I have used.*

# Contents

---



- **Brief history of lasers at AWE**
  - Helen
  - ORION
- **The ORION laser**
  - Configuration
  - Diagnostics
- **ORION experiments**
- **Target fabrication**

**Laser work started at AWE in 1962.  
The AWE HELEN laser opened in 1979.**

---



- **1960 Laser invented**
- **1962 Fusion study at AWE**
- **1971 AWE paper on proposed programme for Laser Fusion studies**
- **1972 LLNL publishes work on Laser Fusion**
- **1975 AWE paper on a route to laser fusion (hohlraums)**
  - **potential for study of materials properties in near-term**
- **1979 HELEN opened**

**HELEN had two long-pulse ( $\sim 1$  ns, 500 J) beams and a CPA backlighter beam ( $\sim 500$  fs, 50 J,  $1.05 \mu\text{m}$ )**

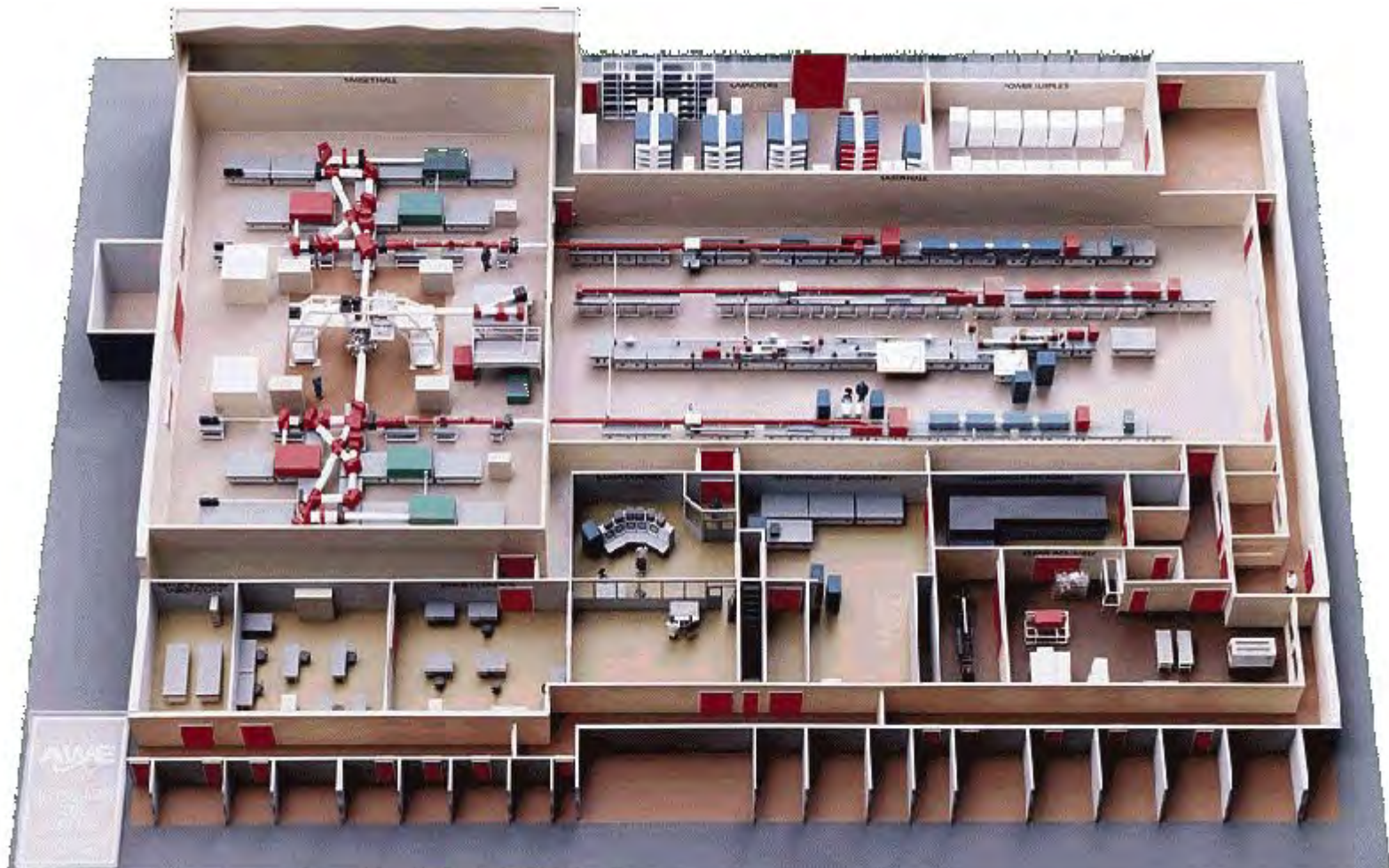

## AWE's HELEN laser: opened 1979



# Laser work started at AWE in 1962

## HELEN laser opened in 1979

---



- 1960 Laser invented
- 1962 Fusion study at AWE
- 1971 AWE paper on proposed programme for Laser Fusion studies
- 1972 LLNL publishes work on Laser Fusion
- 1975 AWE paper on a route to laser fusion (hohlraums)
  - potential for study of materials properties in near-term
- 1979 HELEN opened
- **2009 HELEN closed**
- **2012 ORION open**

**The ORION laser is under construction. Its combination of long-pulse and short-pulse beams will allow us to study materials properties at relevant high densities and temperatures.**



- Long pulse beam for compression
- Short pulse beams for temperature
- Combine to achieve extreme conditions
- ~ 15% of Orion beam-time will be available for collaborators from academia.

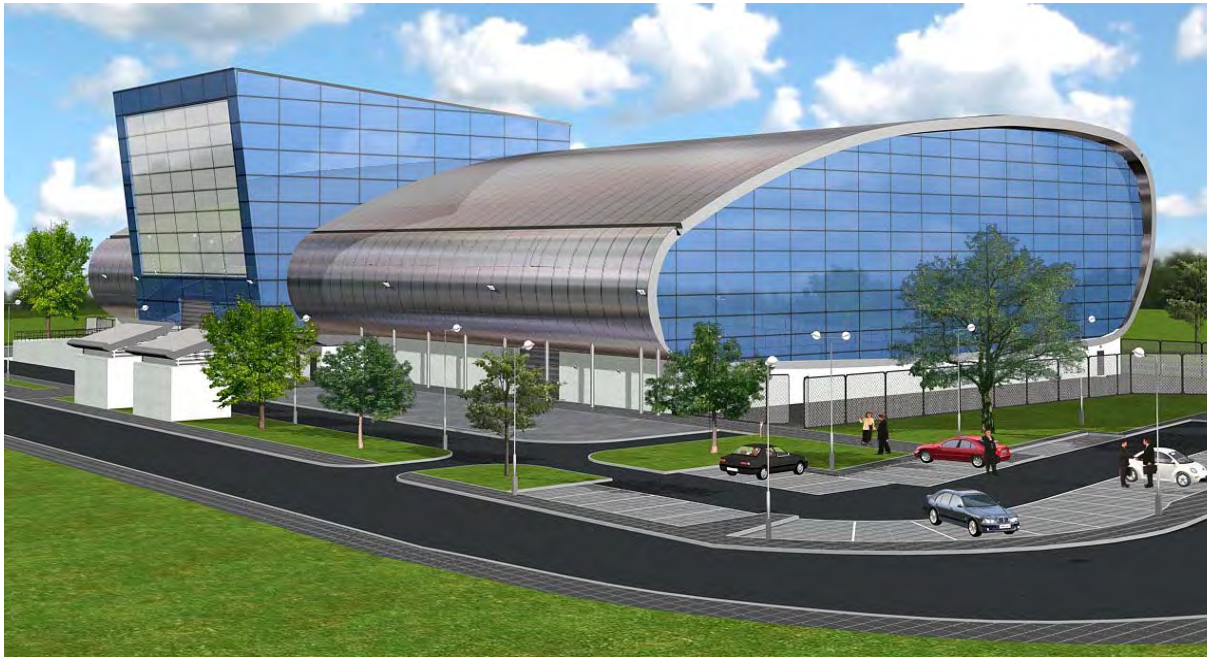

- Ten long-pulse beams
  - 300 mm dia.
  - 500 J per beam
  - 351 nm
  - 1 ns square pulse.
- Two short pulse beams
  - 600 mm dia.
  - 500 J per beam
  - 1053 nm
  - 0.5 ps pulse.
  - $10^{21}$  W cm<sup>-2</sup> using f/3 off-axis focus parabola
  - horizontal on-axis and orthogonal layout
- Extensive diagnostics

# ORION will allow us to explore conditions similar to those reached during the phases of operation of a nuclear warhead.

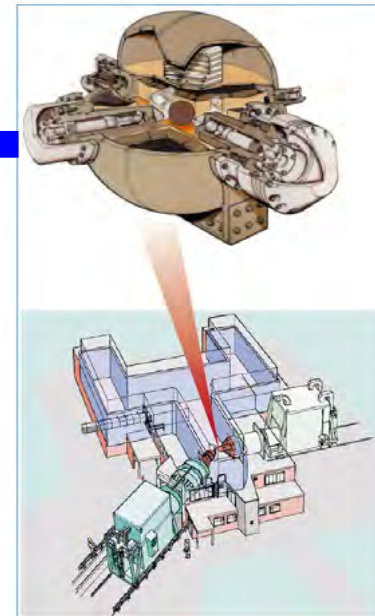
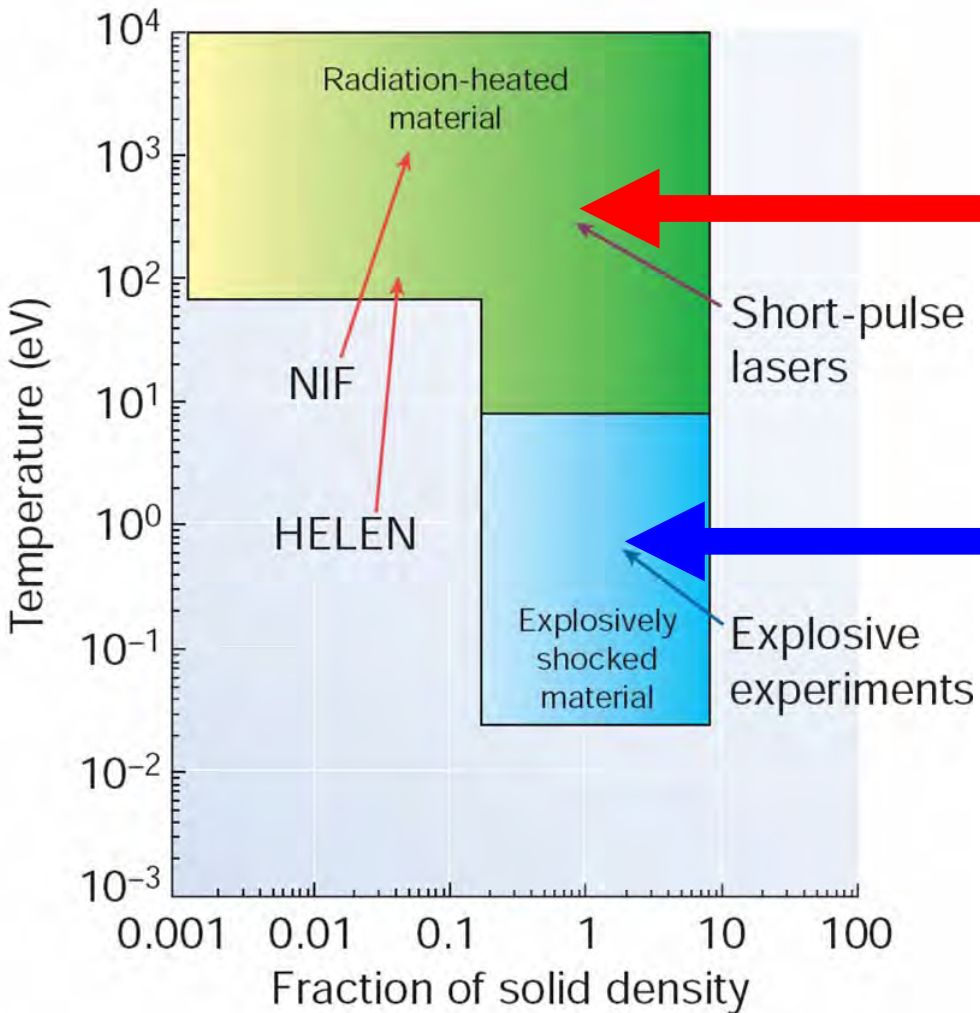





# Schematic of ORION laser and target halls.

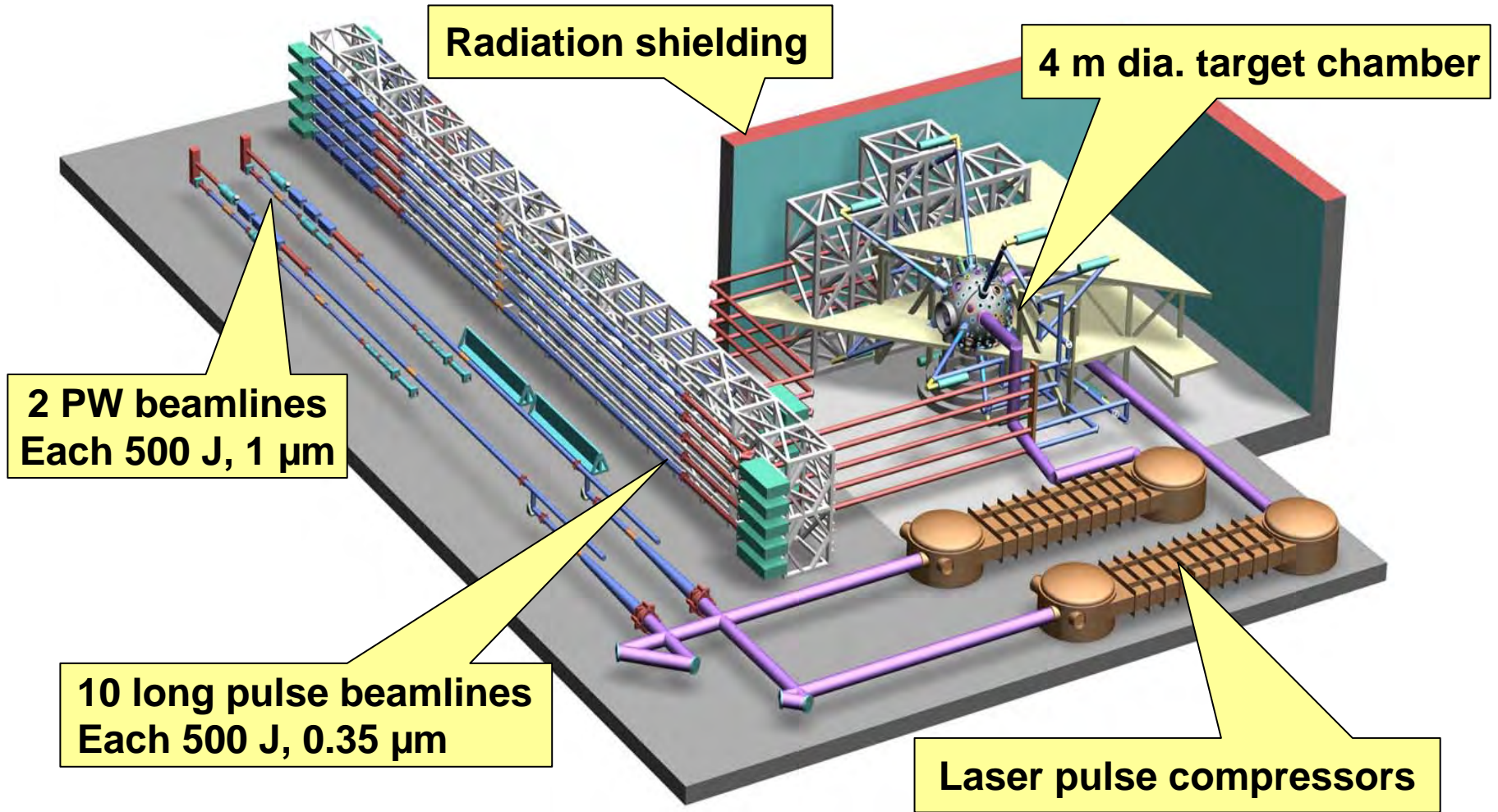

**The laser hall, seen through a laser-light-absorbing filter.**



The ten long-pulse beam-lines are complete and working.



**The two short-pulse beam-lines are complete and working.**

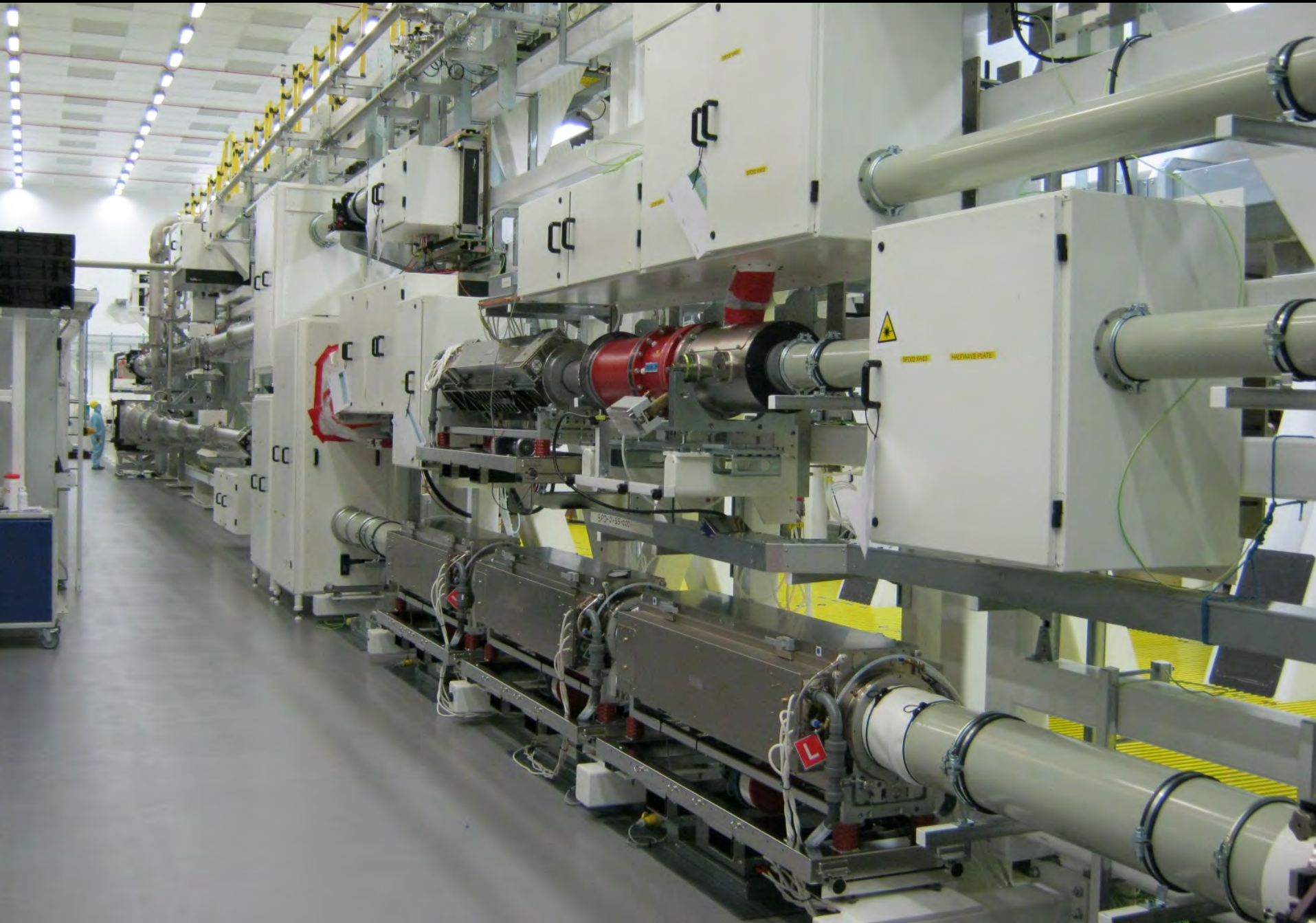

# Compressor hall



**Inside compressor vessel setting up large aperture grating.**



First long-pulse final optics assembly being installed.

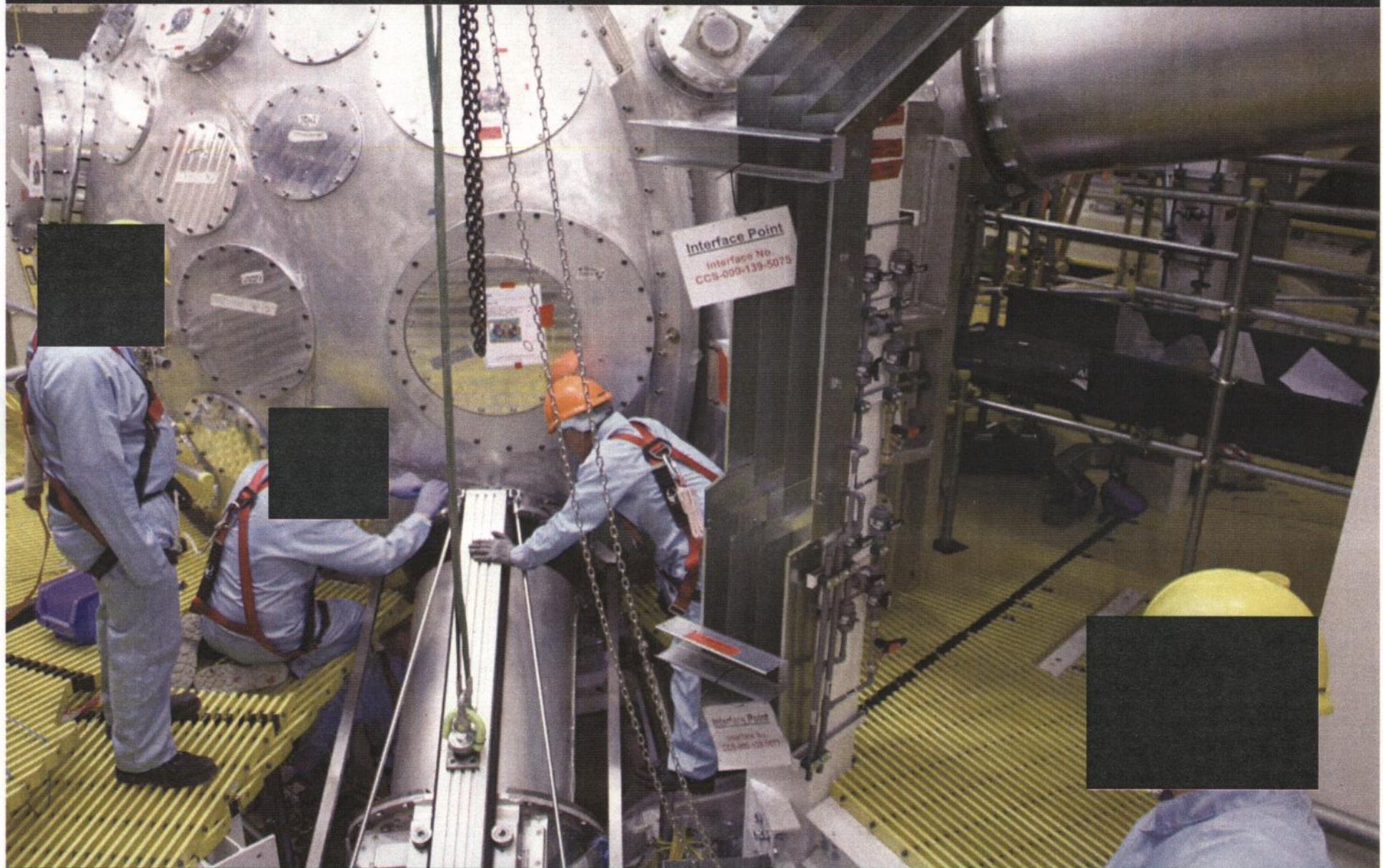



**Above target chamber after installation of target inserter.**

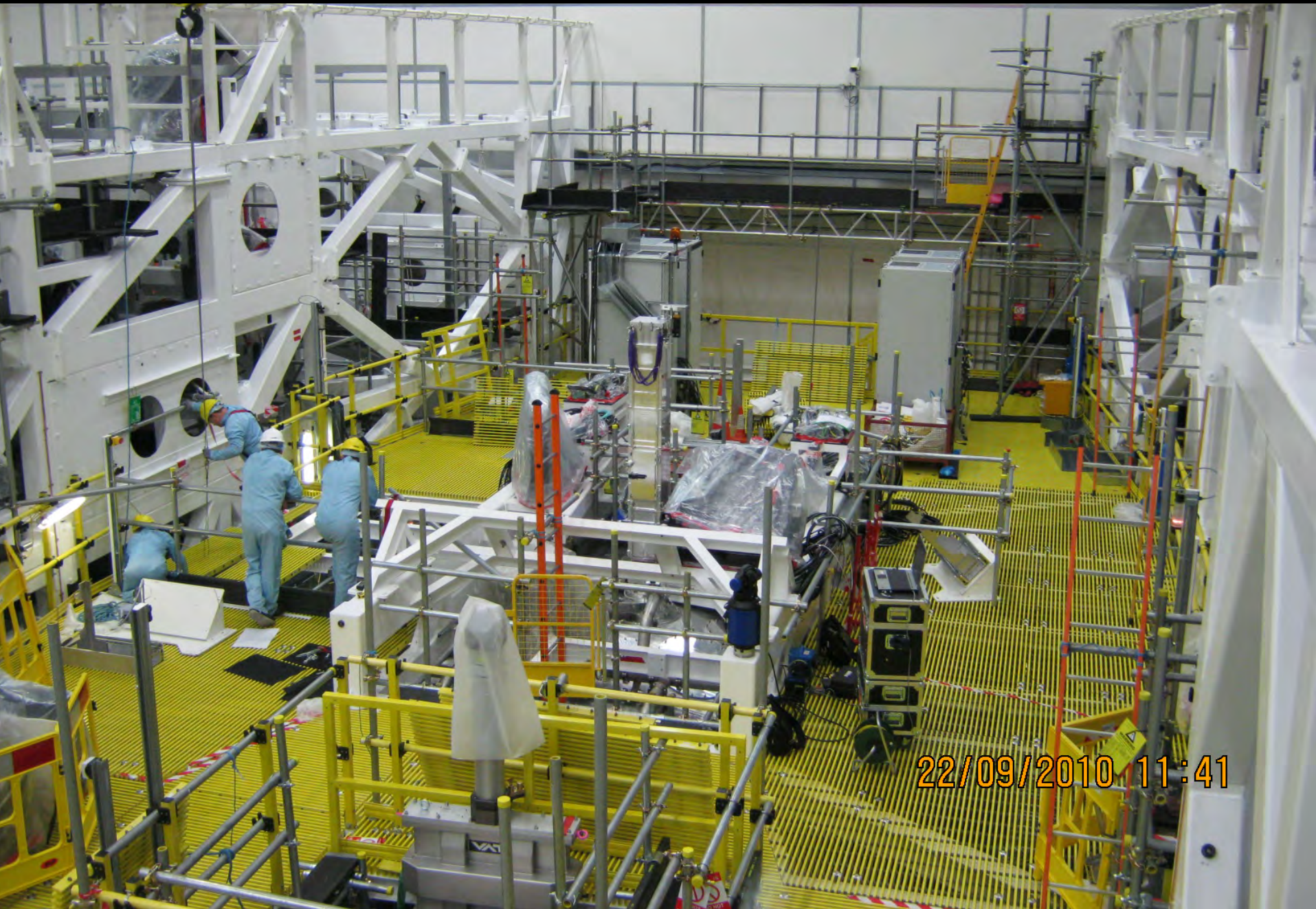

# ORION target chamber during commissioning



09/12/2010 12:13

# Long-pulse synchronisation to within $\pm 50$ ps has been achieved on all 10 beams.

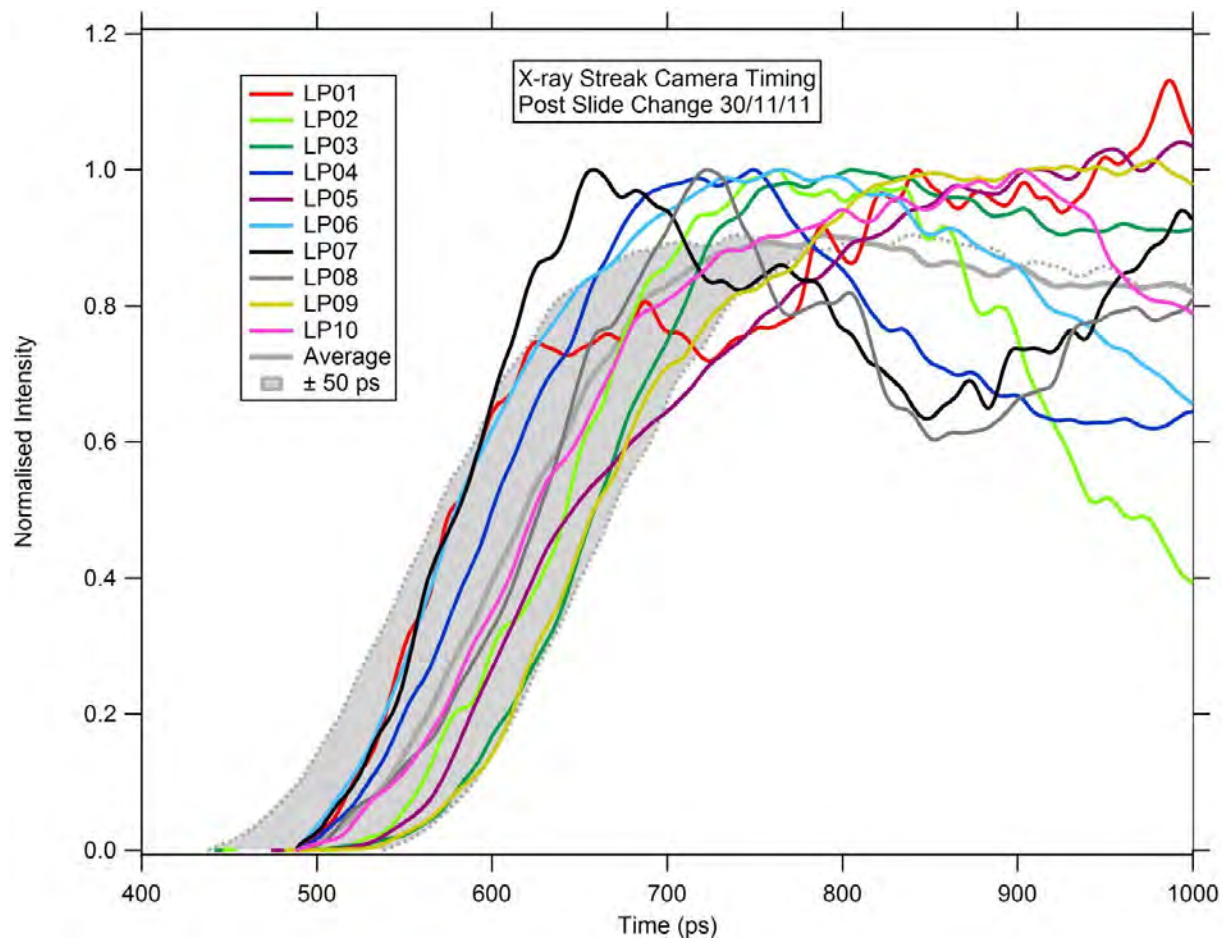

**Pulse-contrast will be an issue for some experiments but is addressed by the availability on ORION of  $2\omega$  light at sub-aperture.**



Some experiments will require the best possible contrast for the PW beams, rather than maximum intensity. Non-linear nature of conversion to  $2^{\text{nd}}$  harmonic provides large enhancement in contrast.

- The option for conversion to the second harmonic at reduced aperture will be provided in a vessel immediately following the compressor.
- Dichroic mirrors leak away residual  $1\omega$  energy.
- $2\omega$  campaigns on HELEN CPA influenced the Orion design.

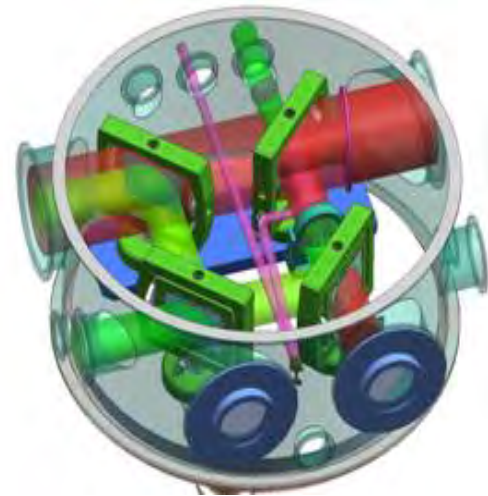
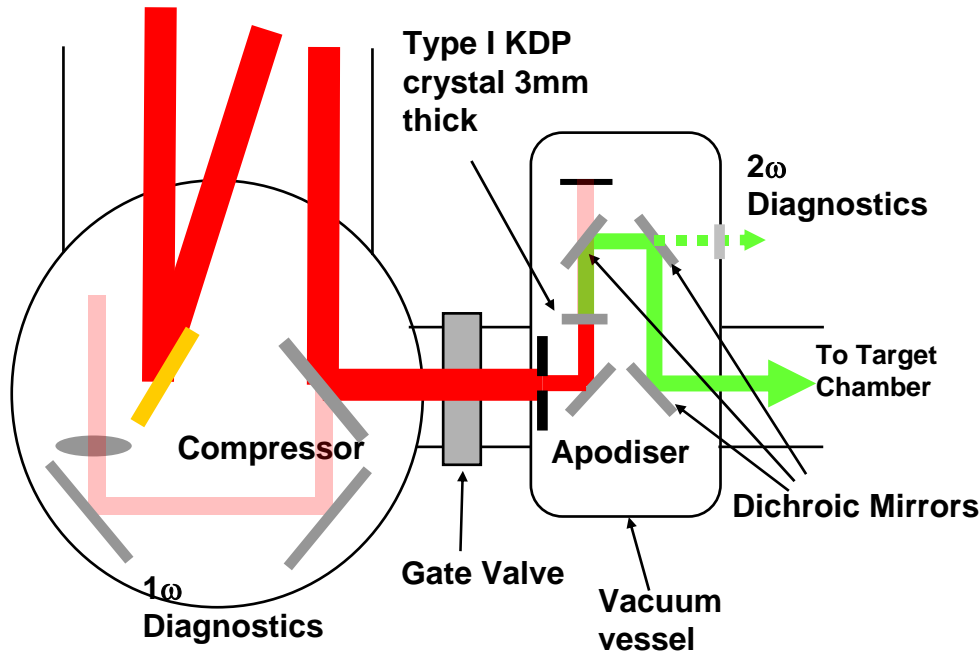

# ORION diagnostics provided by the project include:

---



- **OPTICAL**
  - Optical streak cameras
  - Passive shock breakout
  - Optical pyrometry
  - Active shock breakout
  - VISAR interferometer
  - Backscatter – SRS + SBS
- **PARTICLE**
  - Electron spectrometers
  - Neutron time-of-flight
  - Total neutron yield
  - Neutron spectrometer (later)
- **X-RAY**
  - X-ray microscopes
  - Dante
  - Filter Fluorescer
  - Framing cameras (TIM-compatible)
  - Streak cameras (TIM-compatible)
  - Transmission grating spectrometer
  - Harada grating spectrometer
  - Hard X-ray spectrometer

# The Orion target chamber (4 m dia. Al)



*Endcap omitted for clarity*

Long-pulse  
beam final  
optics  
assembly

Short-pulse-beams  
focussing  
parabolae

“TIM”  
diagnostic  
inserter

Target

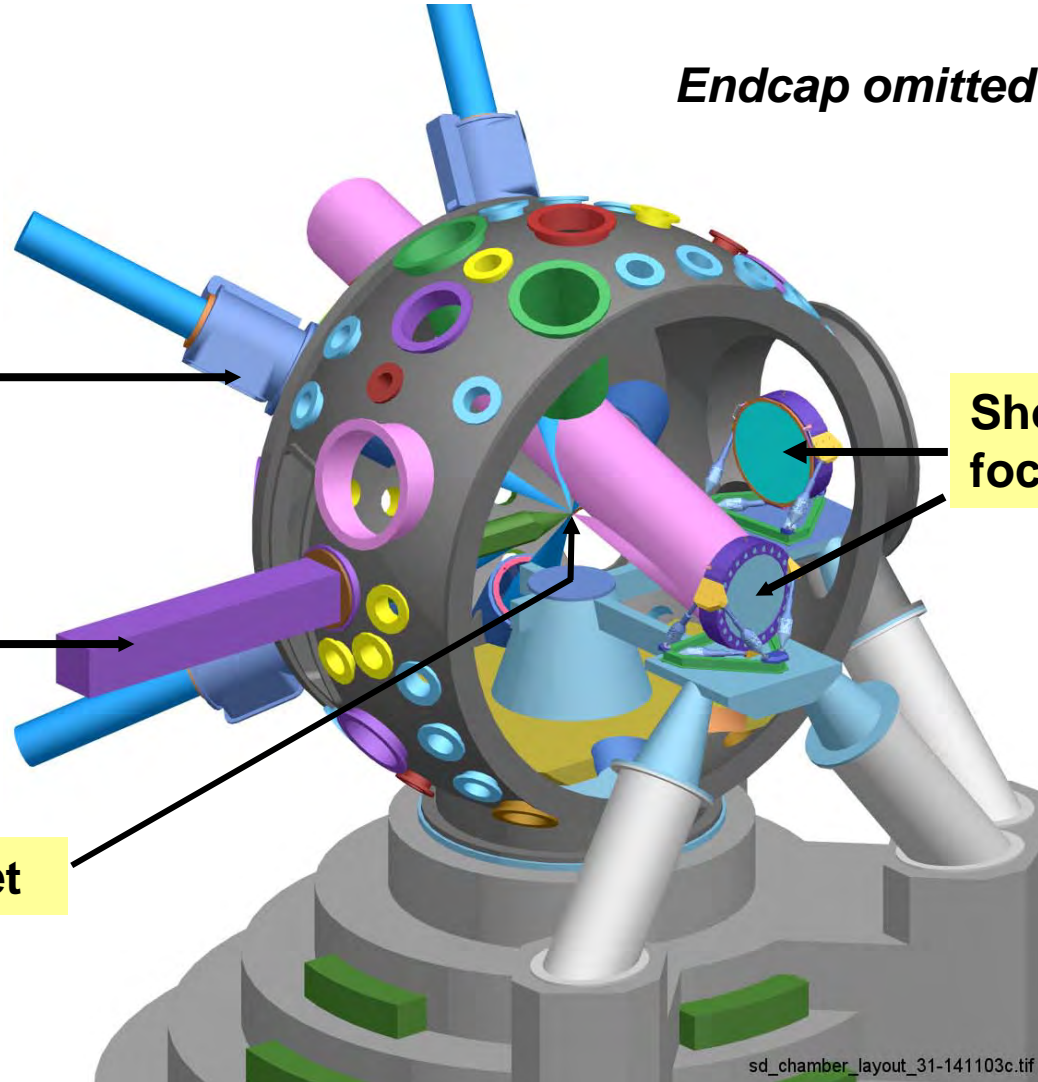

sd\_chamber\_layout\_31-141103c.tif

# Orion has a number of permanently-mounted diagnostics.



Diagnostic	Specification
Optical diagnostic system	PASBO (passive shock breakout), ASBO (active shock breakout), VISAR, pyrometry and probe beam. (NB: front ends of this diagnostic are TIM-mounted)
Dante	Absolutely calibrated, time-resolved soft X-ray (100 eV - few keV) diodes
Filter-fluorescer	Absolutely calibrated, time-integrated X-ray (20 - 100 keV) detector
KB X-ray microscope	Time-integrated imaging (few keV, 10 $\mu$ m resolution)
Full-aperture SRS/SBS backscatter	Long pulse, short pulse and NBI (near-backscatter optical imaging). Time resolved absolute power and spectrum
nTOF neutron diagnostic	Useful range $10^7$ – $10^{11}$ neutrons. Scintillator / photomultiplier
Total yield neutron diagnostic	Copper activation uses rapid transfer and coincidence-counting techniques
Hard X-ray spectrometer	Absolutely calibrated, time integrated X-ray (100 keV - 2 MeV) detectors
Transmission grating spectrometer	Absolutely calibrated time-resolved or time-integrated X-ray diagnostic 120 eV - 1.2 keV
Electron spectrometer (High energy)	50 MeV - 1 GeV energy range

**Some of the diagnostics will be fielded in insertion devices known as TIMs (“ten-inch manipulators”).**



<b>Gated X-ray detector (3 off)</b>	<b>100 eV – few keV with pinhole camera array providing &lt;100 ps gating capability</b>
<b>X-ray streak camera (4 off)</b>	<b>With imaging snout and crystal spectrometer providing ps and sub-ps resolution 100 eV – few keV</b>
<b>Time-integrated (film) spectrometer</b>	<b>X-ray crystal spectrometers</b>
<b>Thompson parabola</b>	<b>Proton spectra 100 keV – 10 MeV</b>
<b>XUV grating spectrometer</b>	<b>Time-integrated or time-resolved measurements 1 nm – 40 nm</b>
<b>Thermoluminescent dosimeters (TLD)</b>	<b>Hard X-ray dose 100 keV – 20 MeV</b>
<b>CR39 &amp; radiochromic film (RCF)</b>	<b>Charged-particle dose and emission profiles</b>
<b>Faraday cups</b>	<b>Time-resolved charged-particle flux measurement</b>



Many diagnostics are deployed on the “Ten-inch manipulator”. It allows them to be inserted without breaking chamber vacuum.

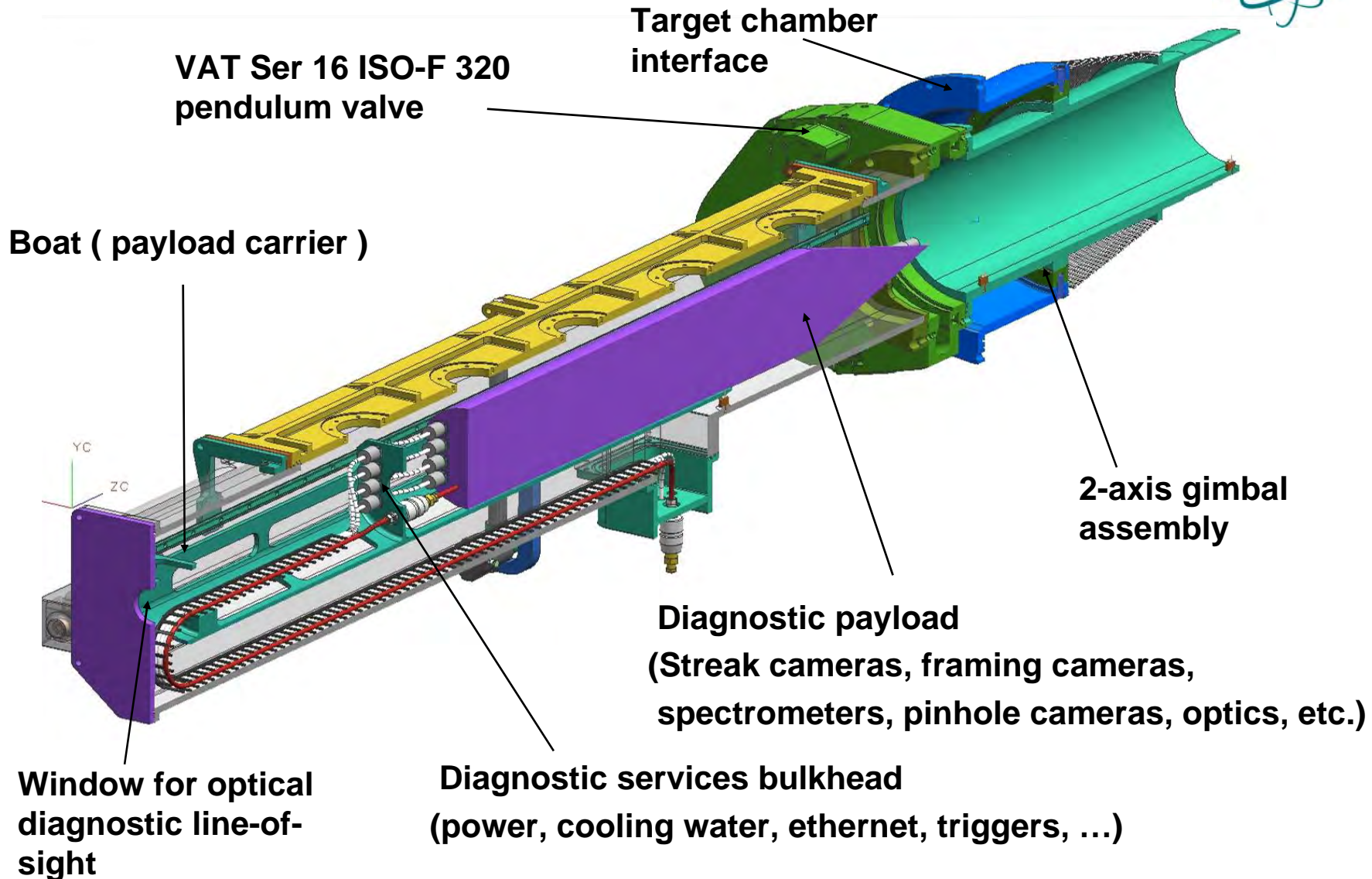

# There are 6 TIMs on the ORION target chamber.

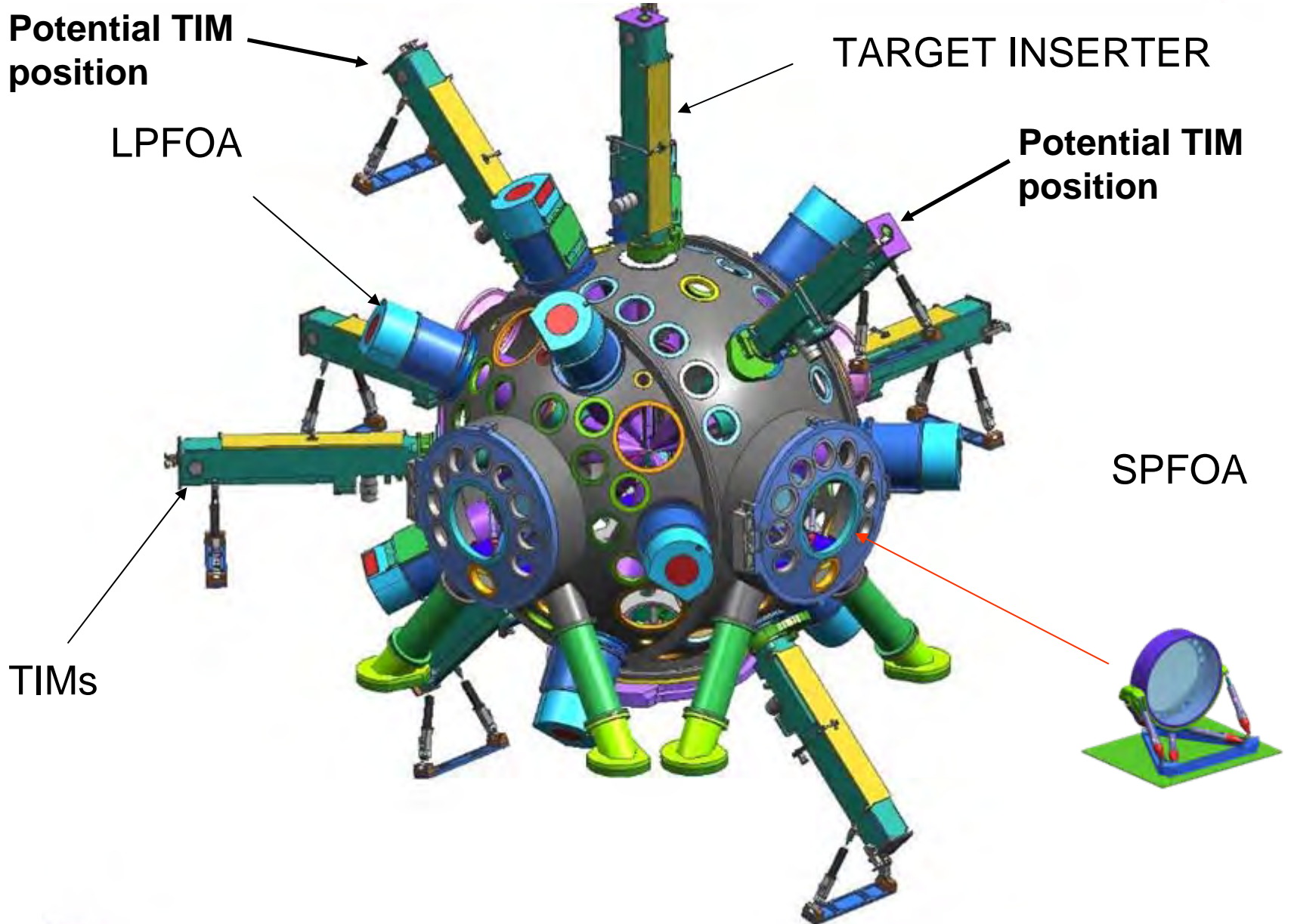

# A laser is used to re-create the extreme conditions encountered in an operating nuclear weapon, but on a much smaller scale.



## Weapon

Temperature ~ 1000 eV (10 million degrees)  
Density ~10's g/cc  
Timescales ~ << microsecond  
Sizes ~ 10's cm

## Laser experiment

*Conditions are close (but not quite) like a UGT*

Temperature ~ 100 - 1000 eV  
Density ~0.01 – few g/cc  
Timescales ~ 0.001 - 50 ns  
Sizes ~ 0.01 - 1 cm

1eV  $\approx$  11,600 Kelvin

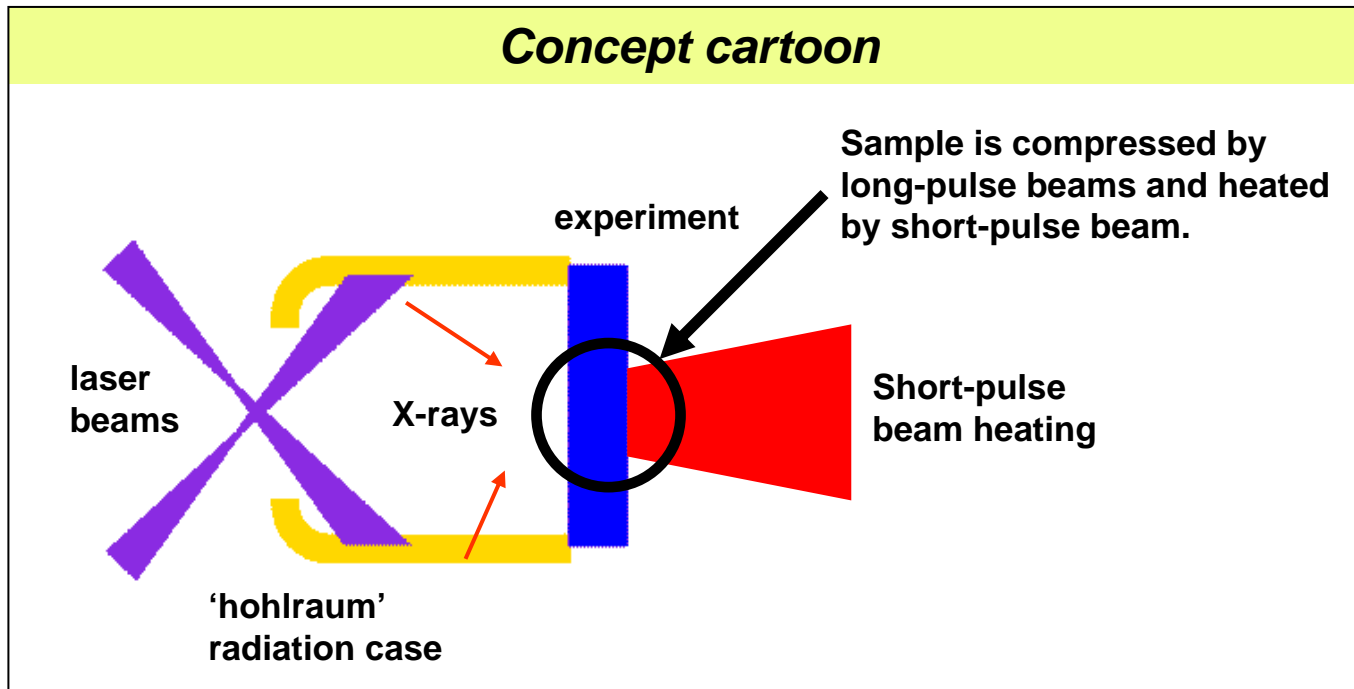

# Likely ORION experiments

---



- **Opacity**
- **Warm dense matter**
- **Strength**

We used the CPA beam on HELEN to perform ORION precursor opacity experiments.



Detector  
(time-integrated,  
time-resolved)

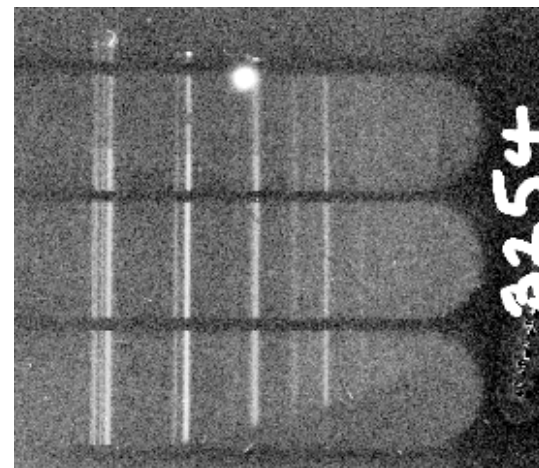
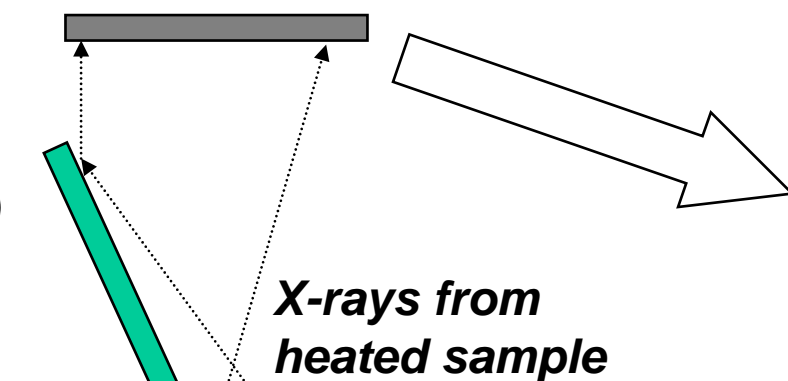

Bragg  
crystal

0.3 $\mu\text{m}$  CH

2 $\mu\text{m}$  CH

100 $\mu\text{m}$  diameter  
microdot or foil sheet

0.05 $\mu\text{m}$  Al

Short-pulse laser-  
beam, either  $1\omega$  (infra-  
red) or  $2\omega$  (green).

Buried micro-dot samples were heated by the 100 TW HELEN beam. The micro-dot was heated by the cold return current.

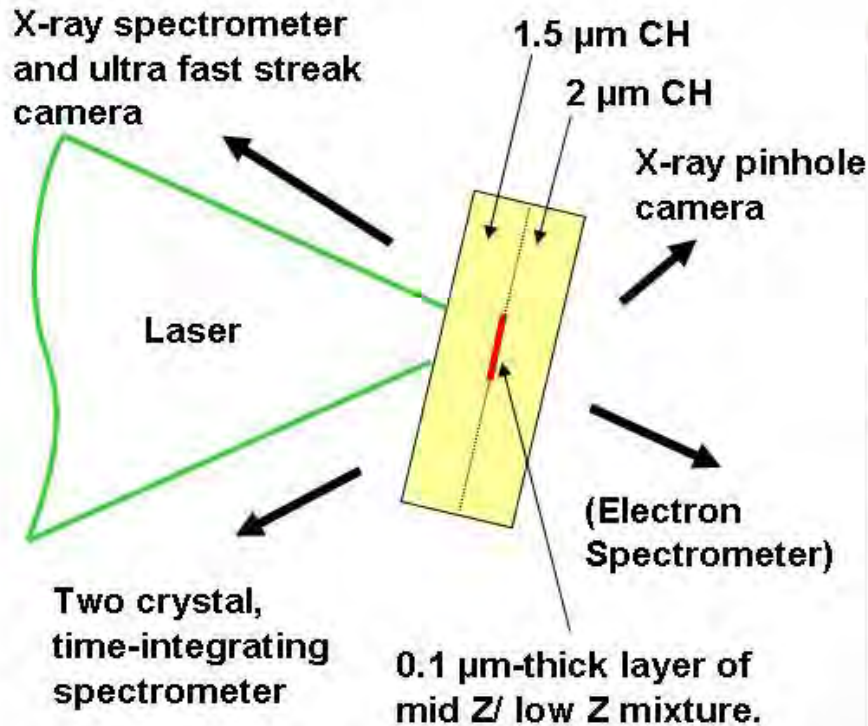

The He $\beta$  /Ly  $\beta$  ratio and the line widths are compared to FLY calculations to infer the plasma temperature and density.

ultra-fast streak camera data show the peak emission lasting ~7ps.

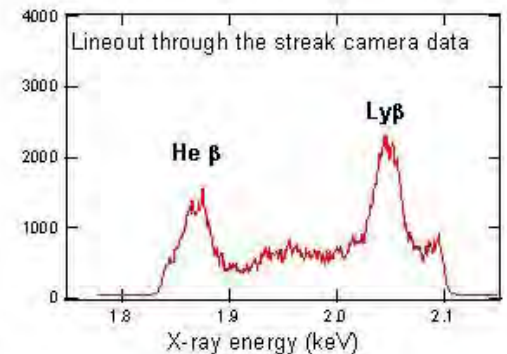
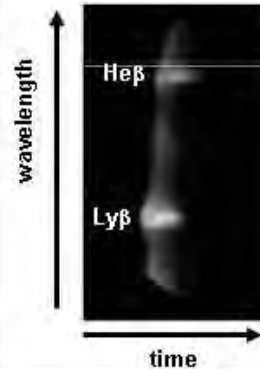
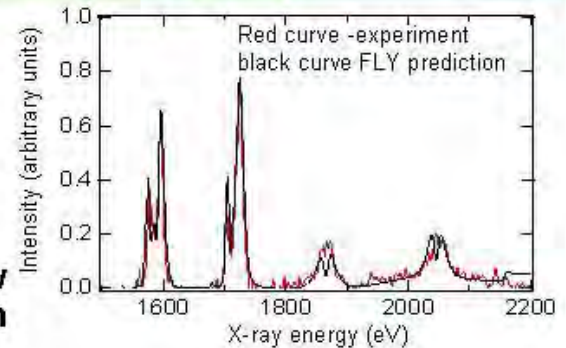

On HELEN we approached conditions of interest, provided that we reduced the effects of preheat.



**RED LIGHT** (i.e. with prepulse)

Best-fit FLY calculation:  
300 eV, 0.25 g/cc

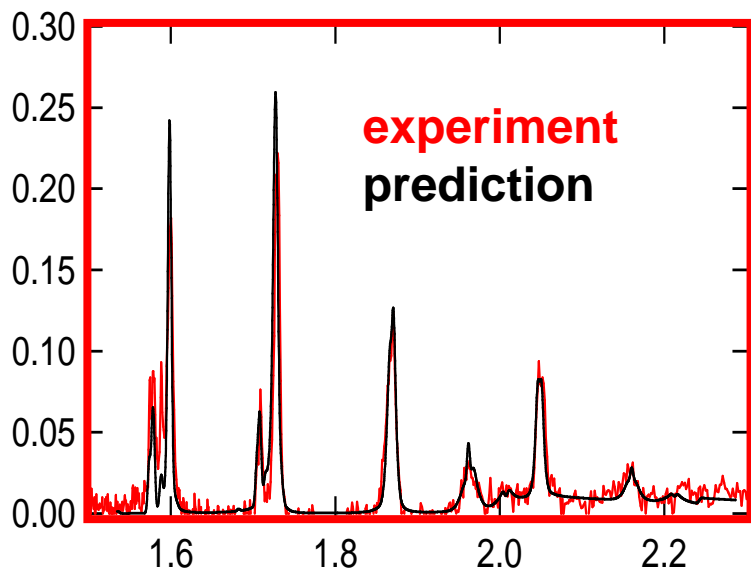

**GREEN LIGHT** (i.e. significantly reduced prepulse)

Best-fit FLY calculation:  
450 eV, 2.7 g/cc

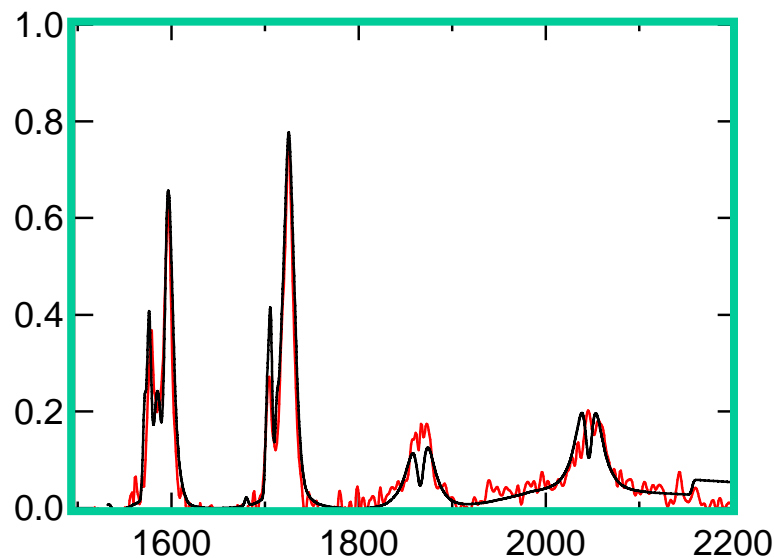

# We need to measure the opacity of materials at greater than normal solid density and temperatures above 100 eV ( $10^6$ K).



- Furthermore, the sample has to be at a well-defined density and temperature – i.e. no significant  $T, \rho$  gradients within it.
- We can achieve this by shock-compressing it, then heating it essentially instantaneously so that the material does not have time to decompress during the experiment – *isochoric heating*.

Short-pulse beam illuminates front of target, launching energetic electrons which isochorically heat the sample.

*X-rays from hot sample are recorded on a time-resolved spectrometer*

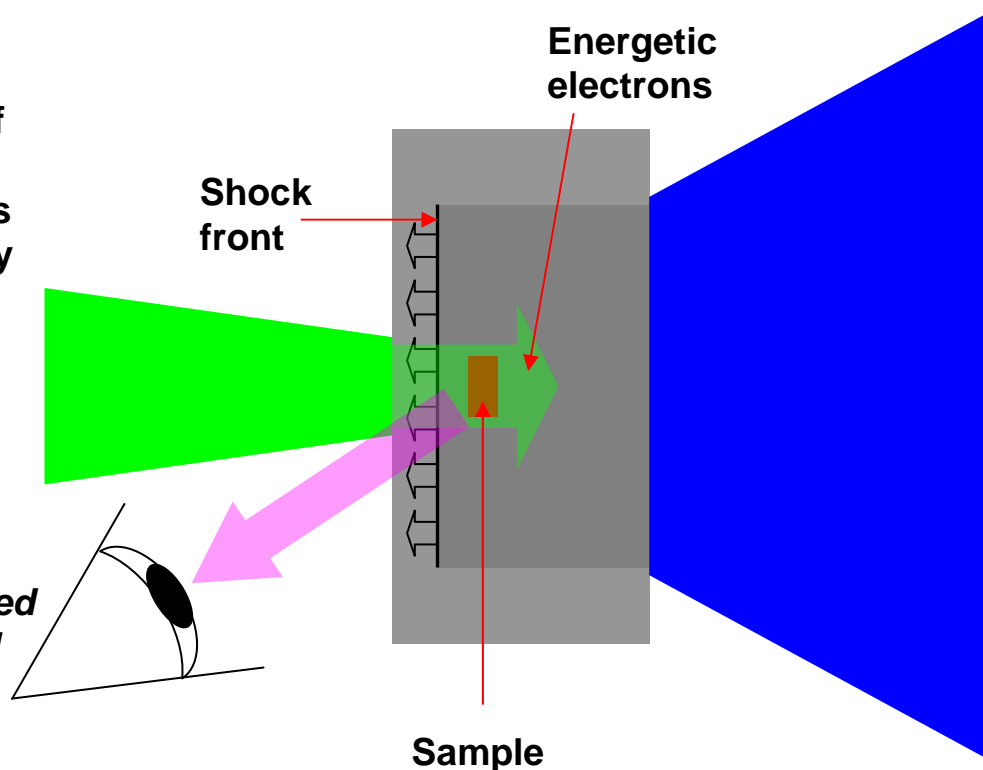

Long-pulse beam(s) illuminate rear of target, launching shock which compresses sample.



# Shocked aluminium experiment streak data: line-broadening is used to diagnose shock compression of an aluminium layer.

Fits indicate compression to 3 g/cc.

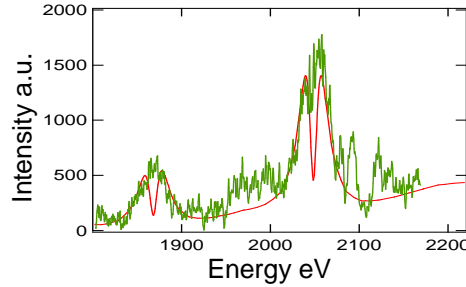

Fits to peak compression indicate density 3 g/cc and peak temperature  $600 \pm 50$  eV.

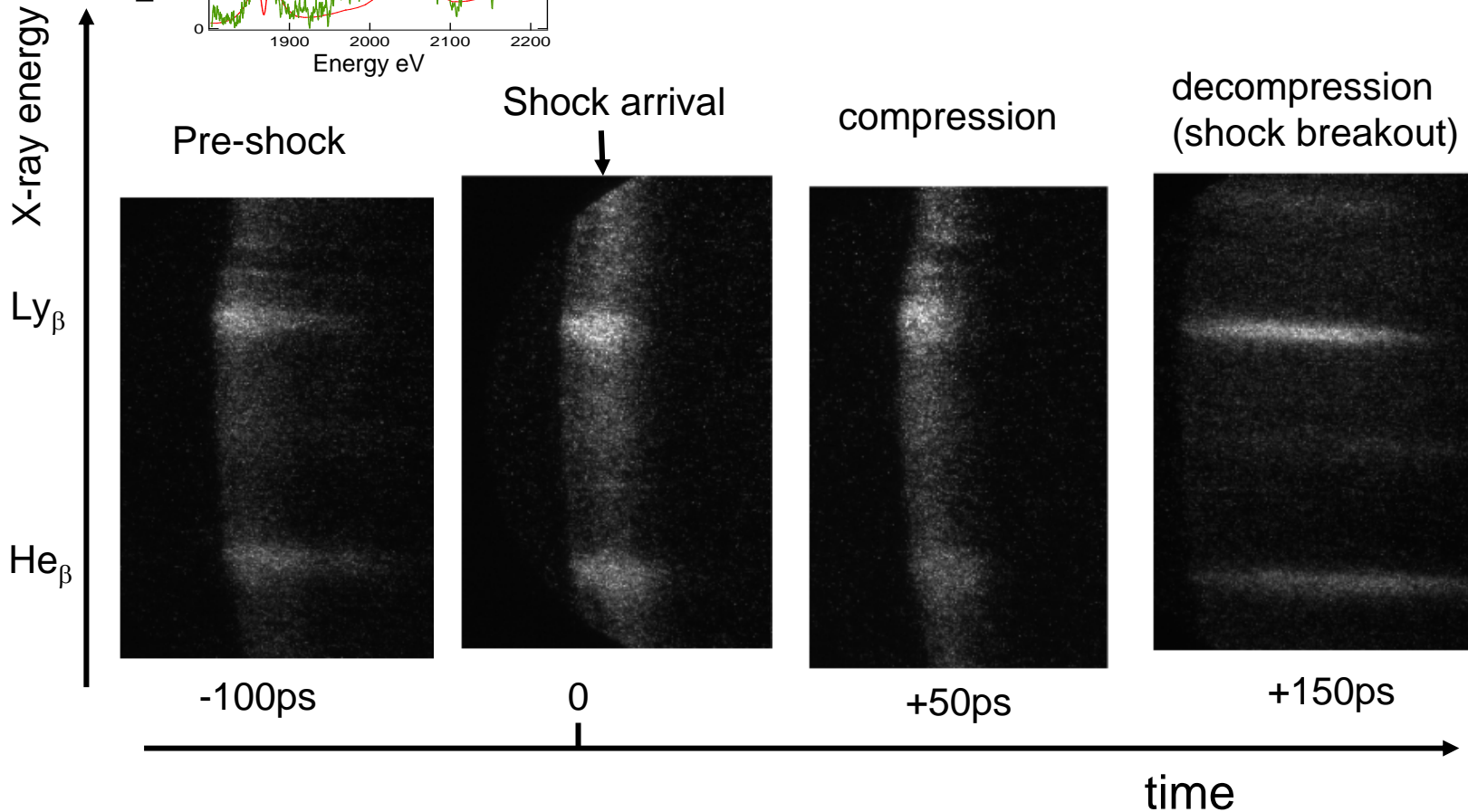

# A shock compression and CPA heating experiment will be among the first measurements on Orion.



Predicted conditions up to 3 x solid at 500-600eV using multiple Orion beams to produce shock coalescence.

Experimental setup schematic

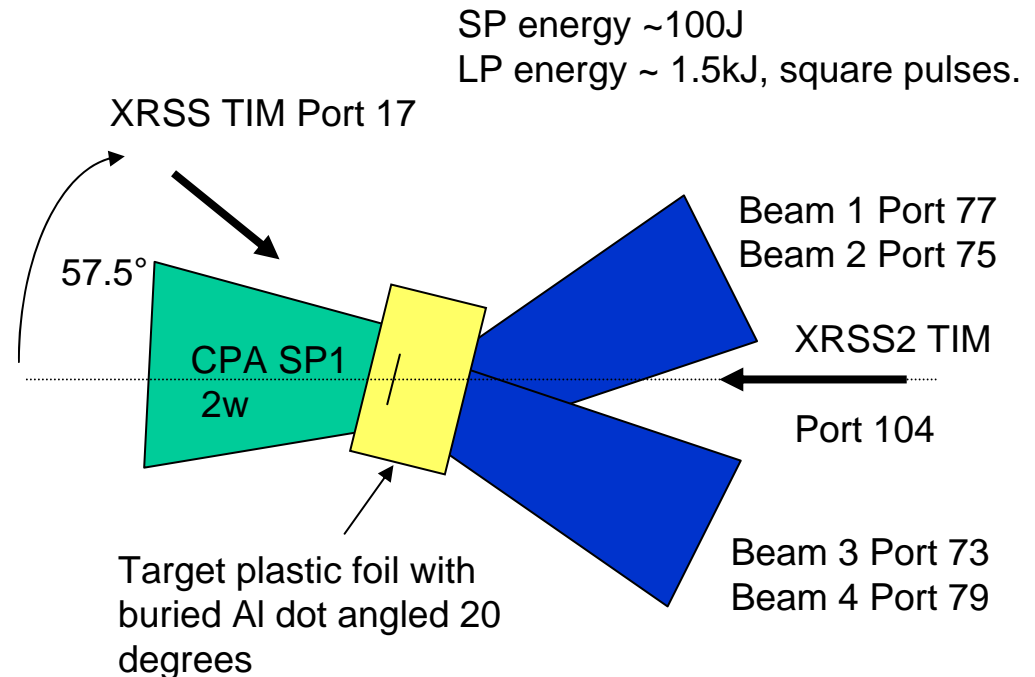
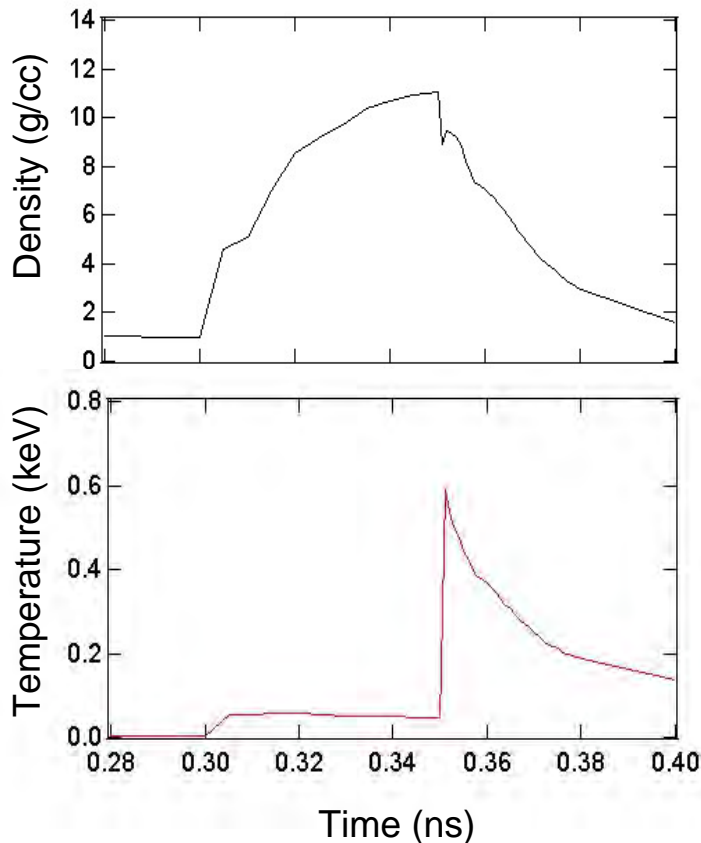

We have measured using HELEN the expansion of proton-heated targets to obtain equation-of-state data.

Similar experiments are being planned for ORION.



- Short-pulse beam illuminates front of target, launching energetic electrons which electrostatically drag protons from front surface of target.
- Protons strike sample, depositing energy, thus heating it isochorically.
- Backlit images provide expansion data

### HELEN data

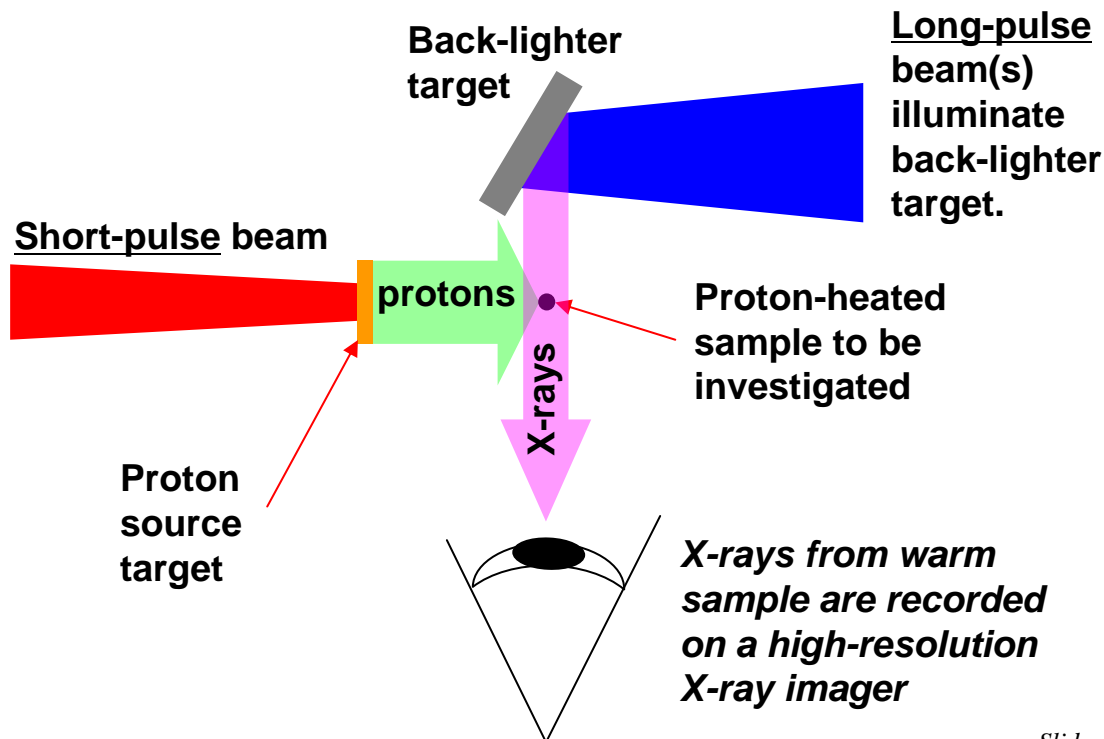
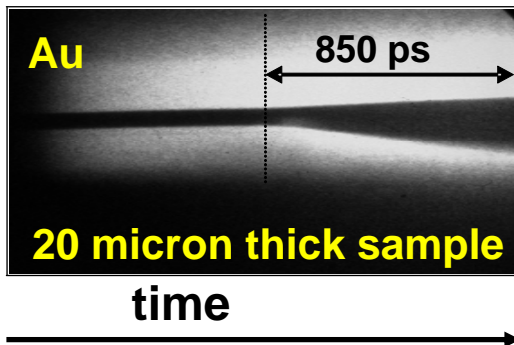
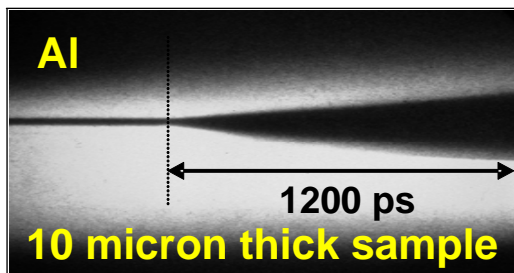

We have measured shock-driven EoS at 10-20 Mb - the most accurate measurements available in this régime.



A material's EoS describes its response to hydrodynamic events (e.g. shocks)

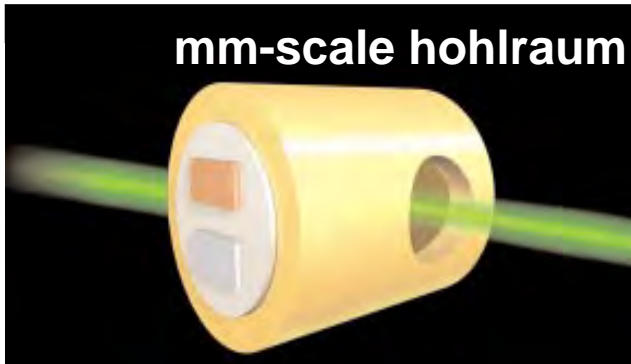

mm-scale hohlraum

Impedance match steps

Spatial and temporal uniformity

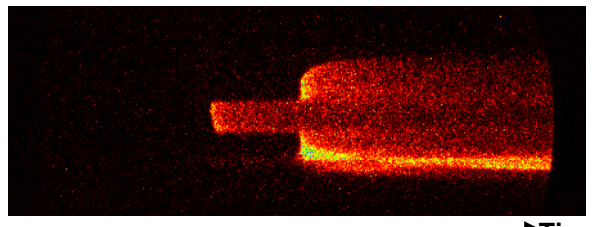
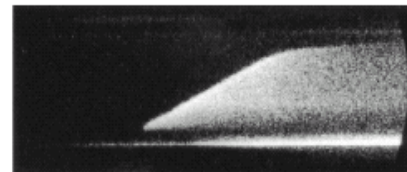
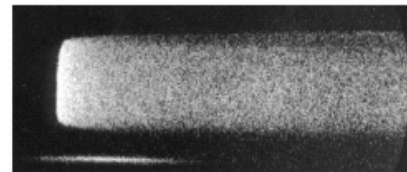

Streak-camera image of shock breakouts.

Copper Hugoniot accuracy ~ 2%

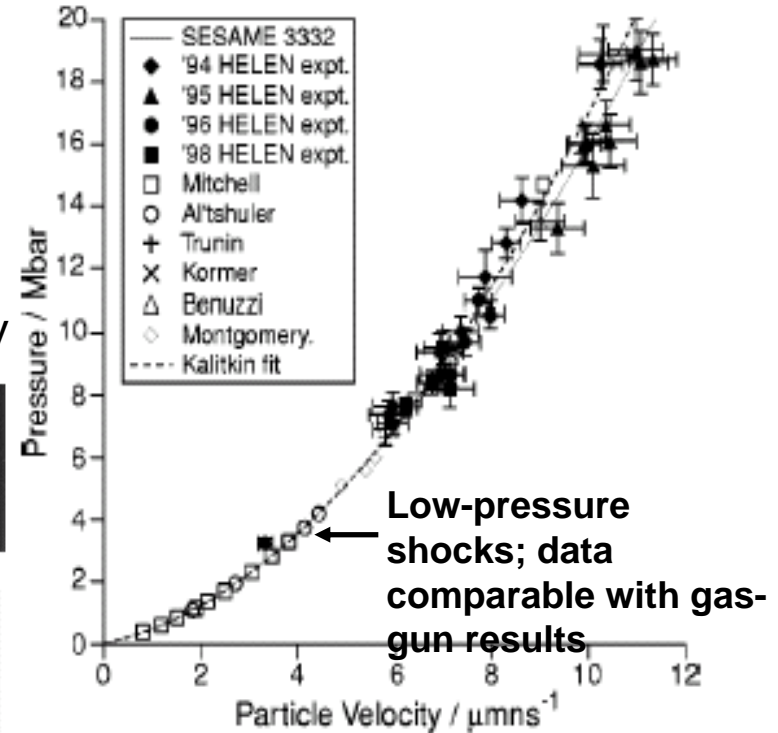

We have performed spall experiments to examine strain-rate dependent strengths.



Interferogram

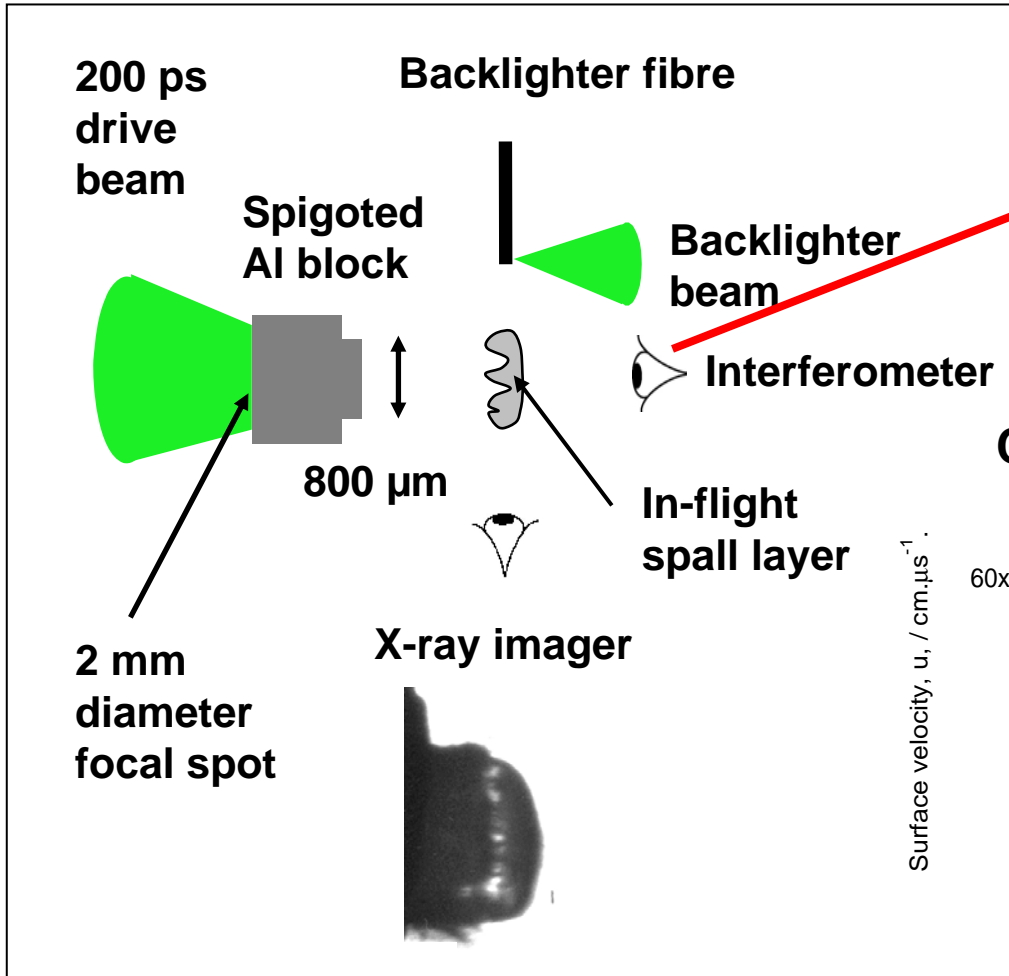
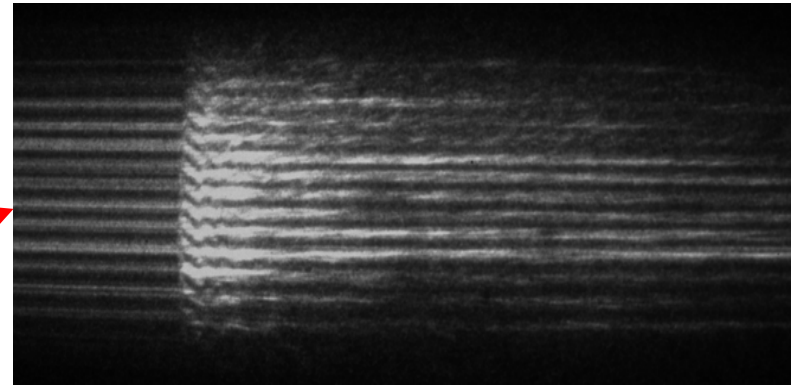

Comparison between expt & model

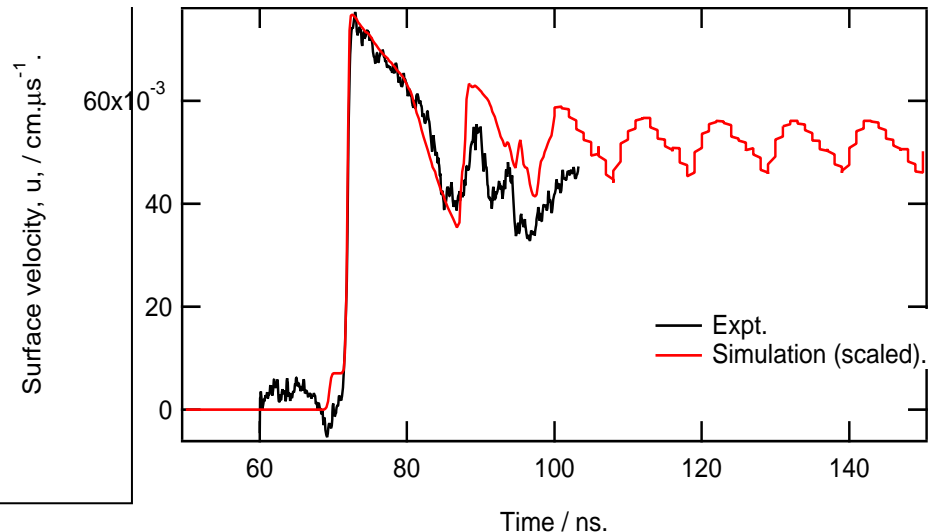

# Transient-diffraction measurements of material response, resolved at the level of the crystal lattice, are being performed on OMEGA and may be performed on ORION.

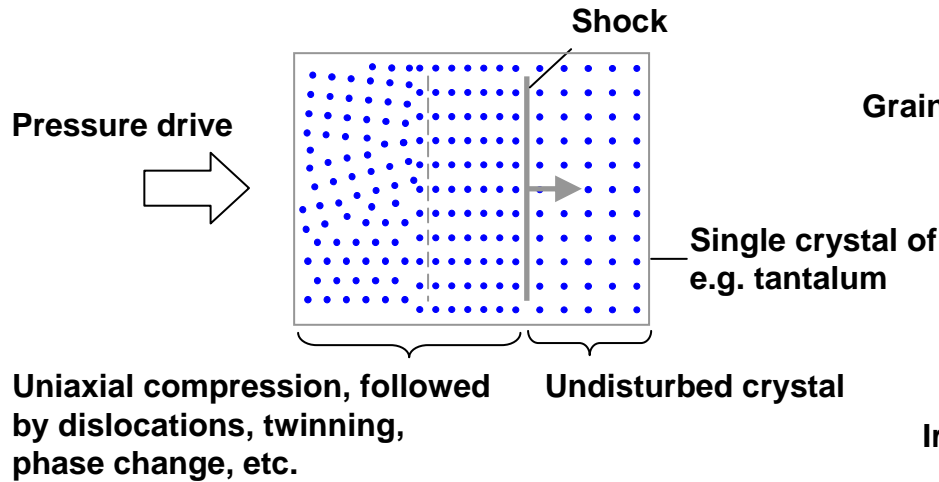

HCP phase      Compressed BCC      Undisturbed

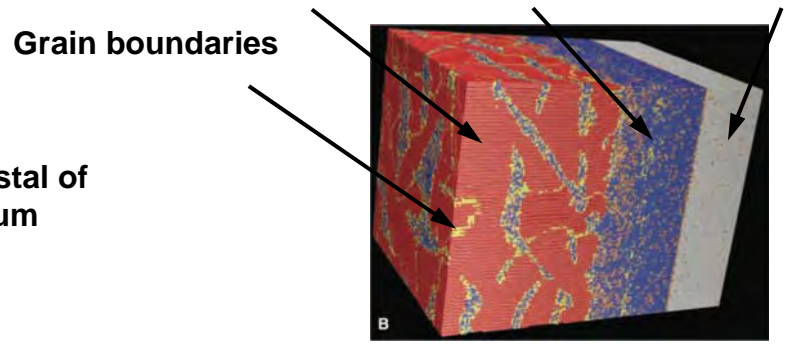

Iron MD simulation, from Kadau *et al.* Science, 296, 1681 (2002)

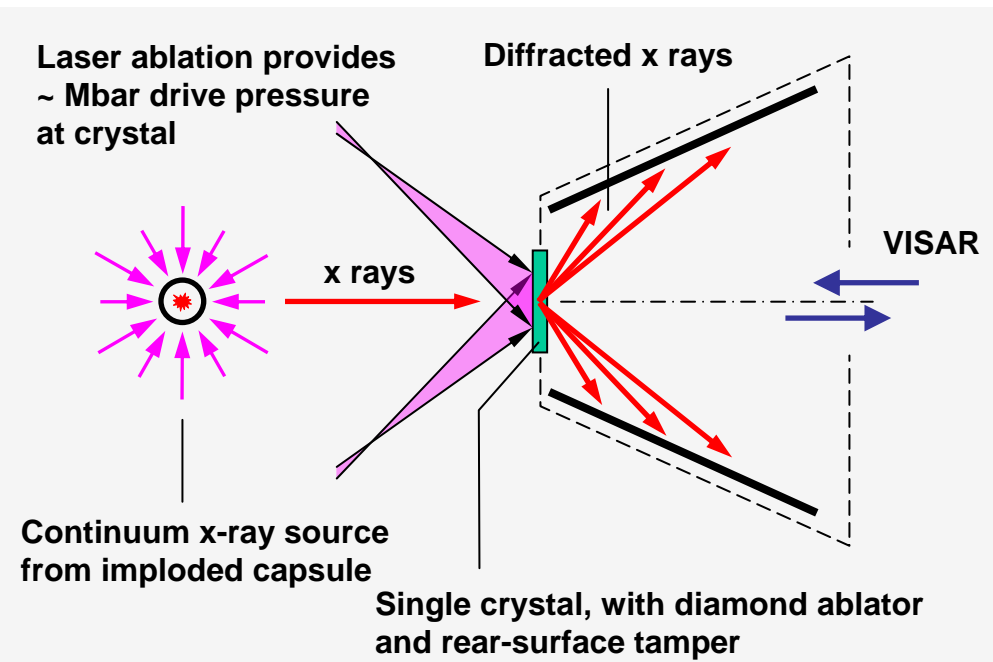

## X-ray diffraction data

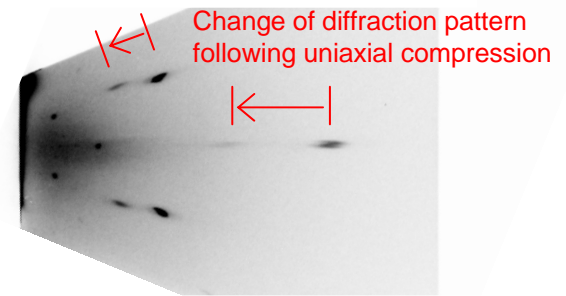

## VISAR records shock breakout at tantalum/diamond interface

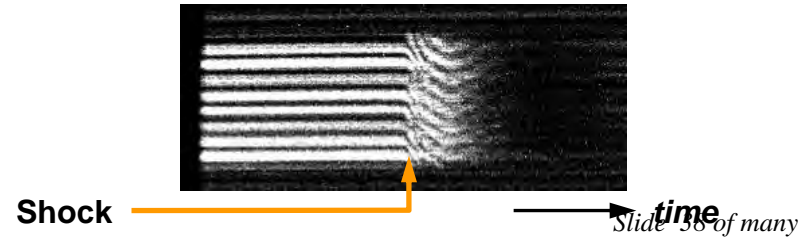

# Up to 15% ORION time will be available to UK academia for collaborative experiments.



## Access available from April 2013

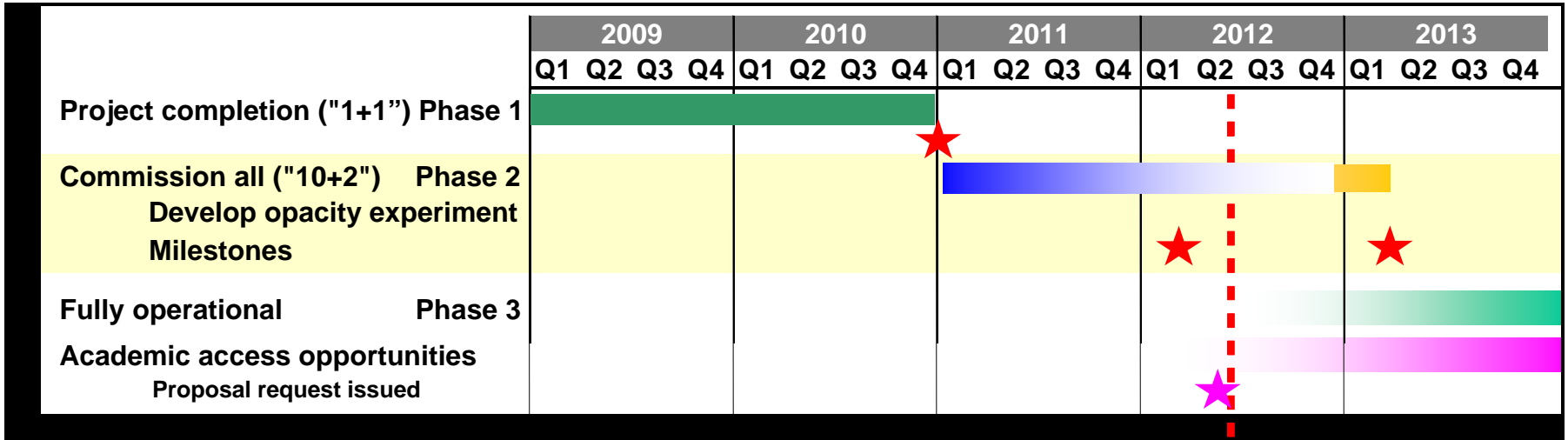

# We are currently commissioning ORION, with a major milestone in April 2013.

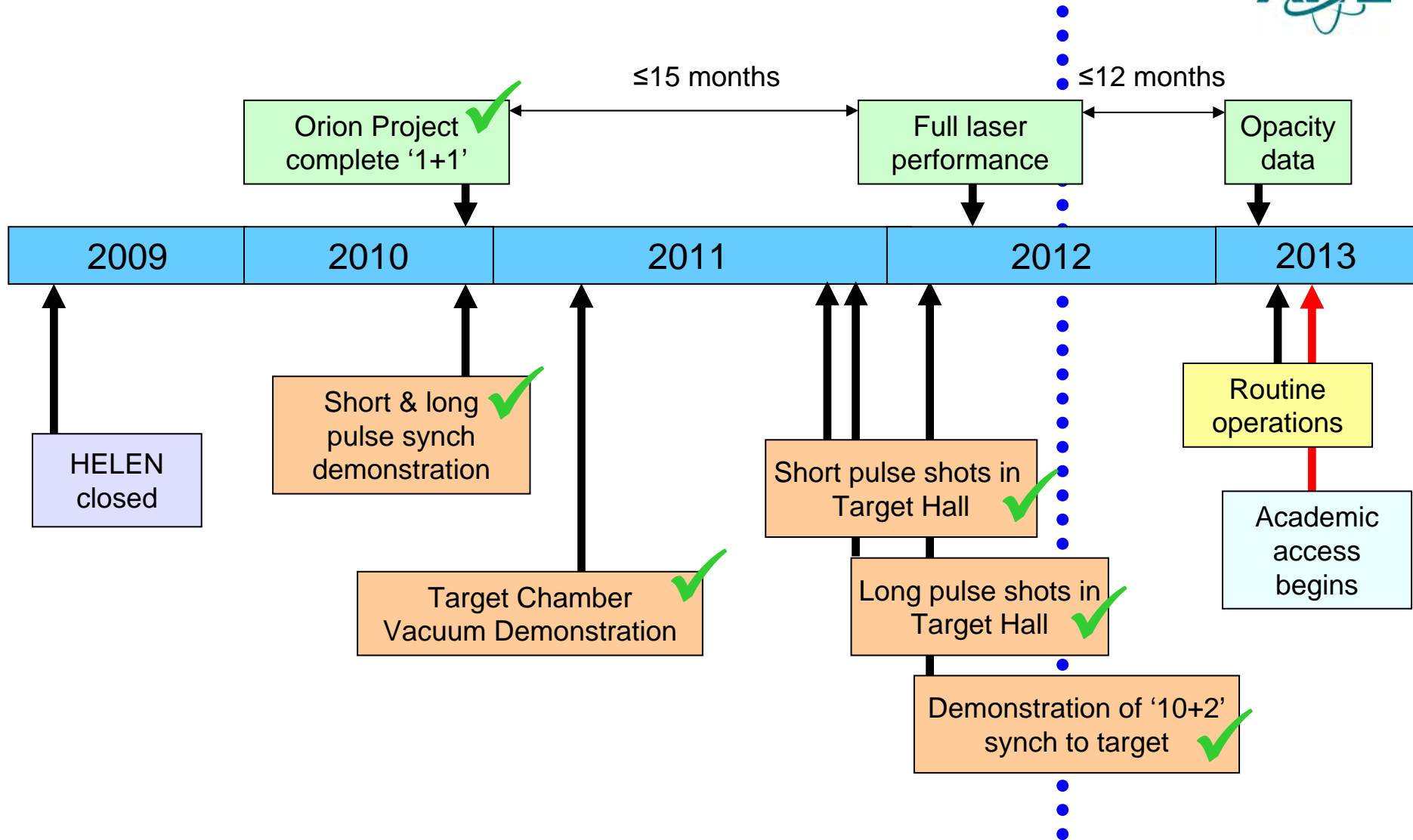



# AWE has an excellent target fabrication capability.



- Laser targets can be very small and complex:
  - $\mu\text{m}$  to mm scale
  - Flat (layered) structures or 3D assemblies
  - Close tolerances -  $\mu\text{m}$  to nm

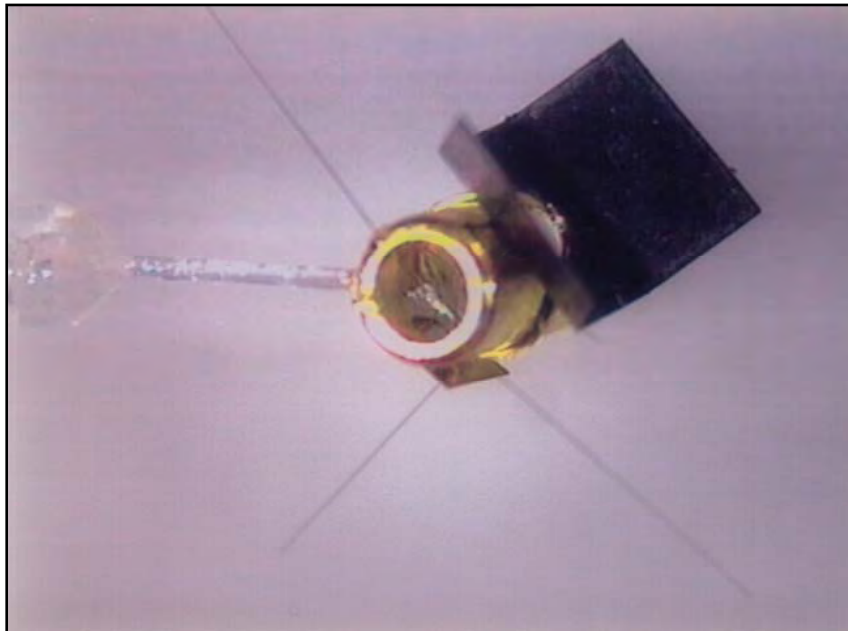

Many technologies and skills are needed in order to produce high-quality, high-precision targets.

Precision machining



Target assembly



Hohlraum target

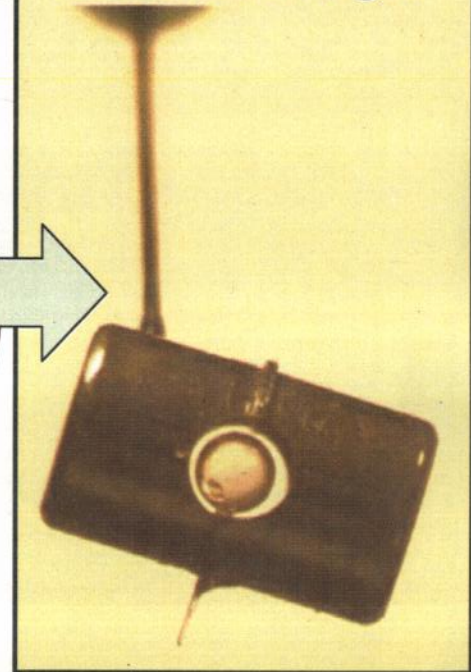

Precision electroplating

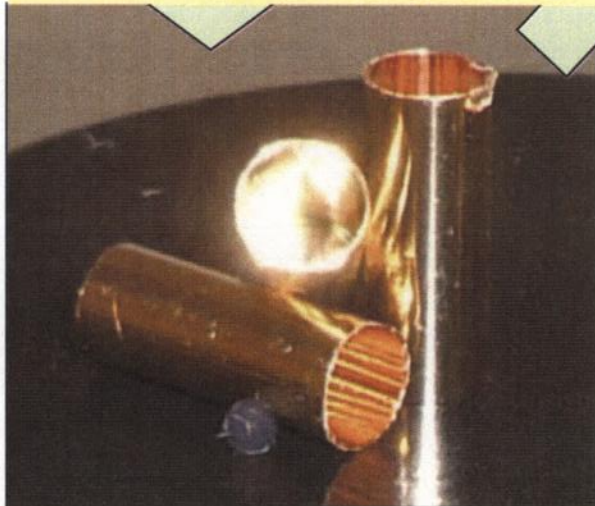

Aerogel sphere manufacture



Thin polymer film development

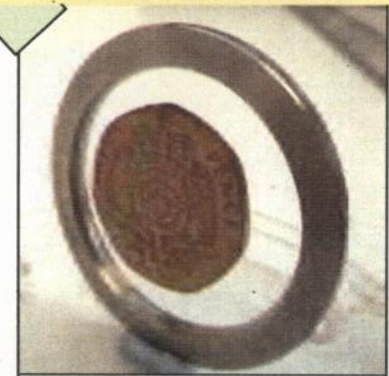

## Target fabrication involves four key themes:

---



- **Materials Science** - *make the raw materials*
- **Engineering** - *form it to the shape we need*
- **Characterisation & metrology** - *do the components meet requirements?*
- **Production** - *assemble the targets*

AWE has expertise in aerogel foams, low-density polymer foams, metal foams, polymeric film development and electroplating.



## HIPE foam development



## Aerogel technology

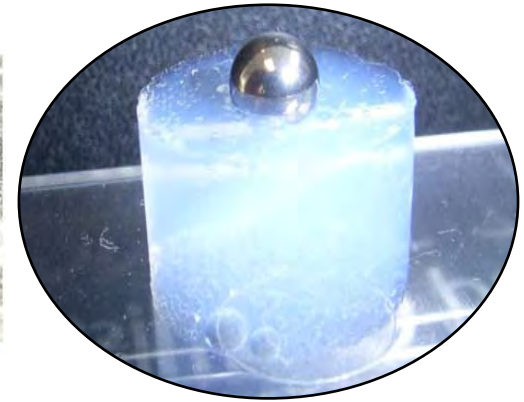

## Precision electroplating



## Sub-micron polymer film development

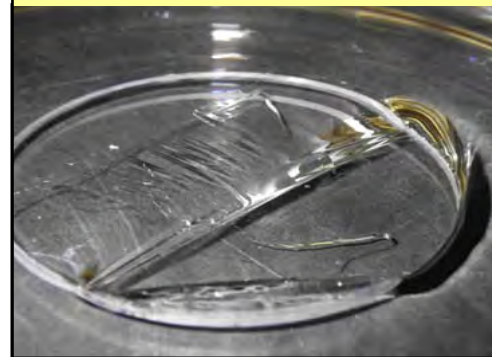

AWE has capabilities in micro-precision turning and milling, femto-second laser machining, and thin-film coating.



Femto-second laser micro-machining

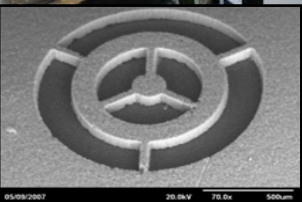
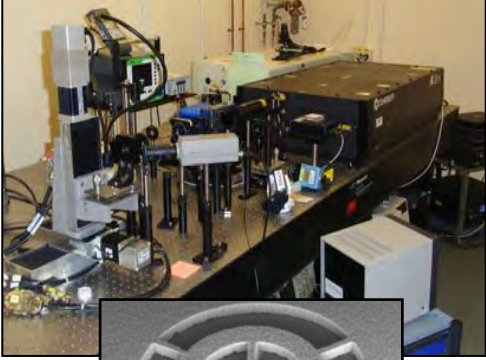

Micro-precision diamond turning



Micro-precision milling



Thin film magnetron sputtering

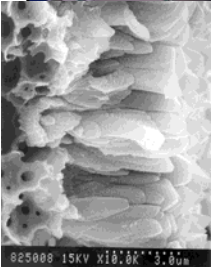

Thin film polymer coating



AWE has a good variety of analysis and measurement techniques for characterising targets and their components.



**Scanning electron  
microscopy**



**Real time precision x-ray  
tomography**



**White light  
interferometry**



**Atomic force microscopy**



**Laser scanning microscopy**



# Production

**AWE Target design, development & production planning, assembly, quality assurance.**



## CAD design capability

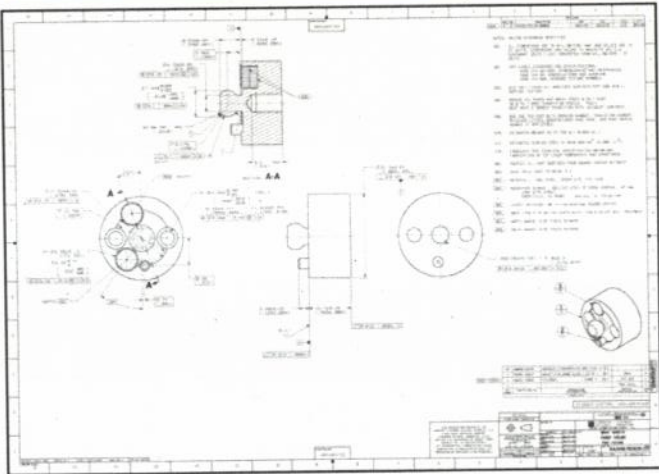

## Development & production planning

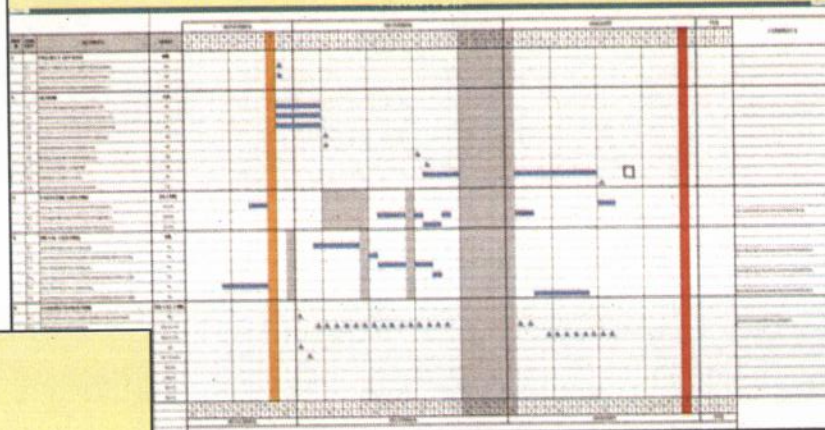

## Target assembly manipulator

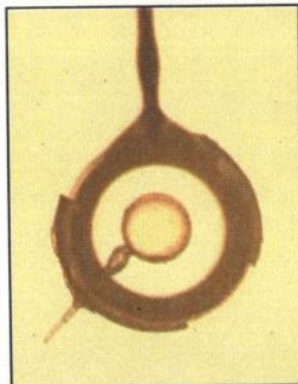
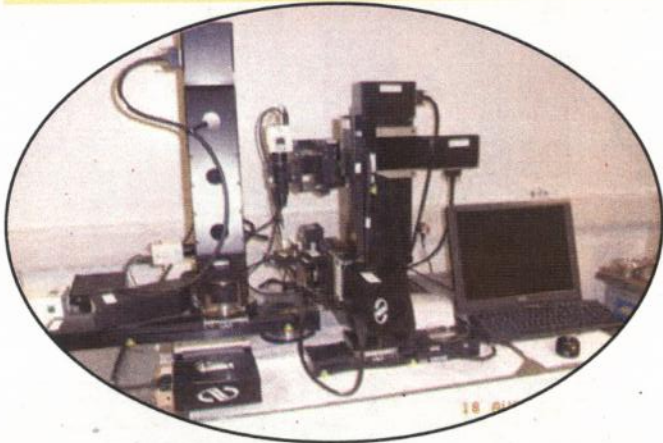

## Target assembly clean room



# Summary

---



- **ORION commissioning underway; commissioning milestone is March 2013**
  - All 10 long-pulse beams are available (~400 J in 1 ns)
  - Both short-pulse beams are available (~300 J in 0.5 ps)
  - All have been synchronised to within  $\pm 50$  ps.
- **During 2012 we are working towards an MoD-mandated experiment milestone (deadline: March 2013) to show that the laser can generate appropriate data**
- **Academic access starts 2013, with 15% of ORION time available.**