

(1828, 1918, 1940, 1958,  
1967, 2017, 2162, 2176,  
2286, 2461, 2486, 2536,  
2609, 2616, 2619, 2650,  
2739, 2780, 2805, 2806)

## SUPPLEMENT TO CERTIFICATE Series S034 Revision 4

issued by:

**The National Measurement Office**

issued to:

**Temptronix Inc  
704-70 Arthur Street  
Winnipeg,  
Manitoba,  
Canada, R3B 1G7**

Authorisation is hereby given by the Secretary of State for Business, Innovation & Skills for the above Certificates of approval relating to a pattern of a liquid flowmeter to be modified as described below.

Certification No.	Supplement No	Certification No.	Supplement No.
1828/40 <sup>*(1)</sup>	60	2486/54*	72
1918/74*	91	2536	78
1940	92	2609 <sup>(1)</sup>	3
1958/53*	76	2616	18
1967/66*	83	2619/43*	61
2017	94	2650/35*	75
2162/92*	110	2739	5
2176/78*	98	2780	25
2286/58*	77	2805	4
2461/26*	41	2806	4

(\*) Refers to the dispenser only, the self service or other devices described in these certificates do not form part of this approval.

(1) These Certificates have expired, but are quoted as they may be relevant for previous versions of this certificate

As described in the above Certificates but modified to have an automatic temperature compensation device (ATC), as detailed in the descriptive annex, and having the following characteristics:-

DISPENSER

Dispensers described in the above certification numbers:

AUTOMATIC TEMPERATURE  
COMPENSATION DEVICE (ATC):

GENIUS ATC for petrol and diesel: software version V1.09.

This revision replaces previous versions of the certificate.

**Issue Date: 16 May 2014**  
**Reference No: T1119/0011**



**Signatory: P R Dixon**  
**for Chief Executive**



## **CONTENTS**

- 1 INTRODUCTION**
- 2 CONSTRUCTION**
- 3 OPERATION**
- 4 CONDITIONS**
- 5 Table 1 Dispenser Model Identification**
- 6 CERTIFICATE HISTORY**

## **ILLUSTRATIONS**

- Figure 1 GENIUS ATC and Enclosure**
- Figure 2 Schematic of ATC Main Board, and Connections**
- Figure 3 Positions of Dip Switches S2 – S5, S6 – S9, S10 and S11**
- Figure 4 Main ATC Board Settings**
- Figure 5 IS Barrier Board and Connections**
- Figure 6 Example Mounting of Temperature Probe**
- Figure 7 Example Mounting of Temperature Probe**
- Figure 8 Example Mounting of Temperature Probe**
- Figure 9 Example Mounting of Temperature Probe**
- Figure 10 Example Mounting of Temperature Probe**
- Figure 11 Example Mounting of Temperature Probe**
- Figure 12 Example of FIM Board**
- Figure 13 Example of FIM Board**
- Figure 14 Example of Sealing Box**
- Figure 15 Example of Alternative GENIUS ATC Enclosure**

# Descriptive Annex

## 1 INTRODUCTION

The GENIUS ATC conversion device, which may be used with up to four metering units, corrects the volume of fuel, measured at base conditions, to an indicated volume at reference conditions (15°C). The Automatic Temperature Compensation (ATC) function is added by connecting the ATC unit between the output from the dispenser pulser and the input to the dispenser calculator. The ATC counts the number of pulses received from the measurement transducer(s), measures the product temperature and uses these measured values and a stored reference density value (kg/m<sup>3</sup>) to calculate the volume at reference conditions. The ATC sends out a number of impulses that is representative for the converted volume, to the connected calculating and indicating device. The temperature measurement is provided by a temperature probe, fitted into the supply pipework, located as close as possible to the meter.

The volume at metering conditions, the product temperature and the selected reference density can be displayed on an inspection display that is fitted to the ATC unit.

## 2 CONSTRUCTION

### 2.1 Main Board

The Genius ATC main board is roughly divided into four quadrants. These correspond to the two (hose) sides (A + B) of a dispenser and the compensated and uncompensated portions of the circuit. The board contains:

- dip switches S2-S5, S6-S9, S10 and S11, which are used to set the device.
- dip switch S12, which is used to set the optional “Mode” features:
  - **No ATC, (spare),**
  - **LCD Alarm Off** and
  - **Buzzer Alarm Off**
  - **Programming Mode**
- an on-board power supply that allows it to be powered directly from a mains voltage source (100Vac to 260Vac).
- a 16 x 2 character LCD display that provides the user with information. The display is backlit and can be equipped with an optional screen heater to allow for visibility down to -40 °C.
- Calibration and Reset switches.
- Function select (positions 1-5) rotary knob and function activate button

#### 2.1.1 Function select

- position 1: Side A + Side B Total. This setting displays the compensated and uncompensated values for all fuel that has flown through the dispenser. It sums up all compensated and uncompensated volumes, regardless of density or product.

- position 2: Totals Product 1 – 4. This setting shows the compensated and uncompensated volumes for each individual product. Each product is shown for a few seconds and then the next product information is shown in a cycle. The cycle can be stopped at any time by pushing the red Function button. Pushing the button again will begin the cycling again.
- position 3: Last Fill Information. This setting displays the compensated and uncompensated data from the last fill for side A and side B of the dispenser.
- position 4: Product Densities. This setting shows the current product densities for each grade on side A and side B.
- position 5: Product Temperatures. This setting displays the current temperatures as measured by the temperature probes.

## **2.2 IS Barrier Board**

The Intrinsically Safe (IS) ATEX approved barrier board is mounted above the main board inside the ATC enclosure. The IS barrier is encapsulated in a black epoxy (Hysol) for ATEX compliance, and is spatially divided into safe and unsafe zones. The probe wires emanate from the epoxy and are connected to the thermistor probe(s) via a terminal block mounted on the enclosure.

## **2.3 Software**

The software version number, 1.09, is shown on the ATC's inspection display during start-up.

The software is not divided into two parts, i.e. Weights and Measures and non-Weights and Measures.

## **2.4 Temperature Probes**

**2.4.1** The probe is a type W199-4 ATEX. The probe is positioned in the most practicable location for the dispenser type, which can include the discharge side of the pumping unit to the meter inlet(s), or in the pipework between the pump unit and meter(s). Examples of the most common installations are in Figures 6, 7, 8, 9, 10, & 11. An optional Thermal Test Well may be located adjacent to the probe for use with another temperature sensor, in checking that the probe is operating correctly. Where this Test Well is fitted, it shall be covered with a plug to prevent dirt entering the Test Well. The W199-4 temperature probe is connected to the IS barrier board.

## **2.5 Conversions**

The ATC can perform conversion calculations according to the following methods:

- API MPMS Chapter 11;
- ASTM table D1250-04, 54B (Refined Petroleum Products)

The conversion is based on the measured volume at metering conditions, the measured product temperature and a stored product reference density value (kg/m<sup>3</sup>). The product reference density is the density at a product temperature of 15 °C.

The following product densities are available:

Petrol Unleaded Premium - 730 kg/m<sup>3</sup>

Petrol Unleaded Super - 736 kg/m<sup>3</sup>

Diesel - 839 kg/m<sup>3</sup>

Gas Oil & Marine Diesel - 853 kg/m<sup>3</sup>

Other Product Density - Input any value from 500 kg/m<sup>3</sup> to 999 kg/m<sup>3</sup>

### **3 OPERATION**

**3.1** The GENIUS ATC incorporates a Universal Pulse Adapter, which is a digital algorithm that can detect the pulser pattern and emulate it at the output so that little configuration is required and no hardware adapters are required. The system counts the number of pulses received from the measurement transducers, impulse encoders (level A as per API chapter 5 section 5, double channel, 90° phase shift), measures the product temperature and uses these measured values and a stored reference density value (kg/m<sup>3</sup>) to calculate the volume at reference conditions. The ATC sends out a number of impulses, that is representative of the converted volume, to the calculating and indicating device.

**3.2** The program code and conversion tables are stored during normal use in the unchangeable EPROM. They are protected against errors with a 16 bit checksum. The appropriate portions of the EPROM are summed directly after the start of every transaction on either the A or B side of the dispenser. In addition to protection against changes of the EPROM the system checks against loss of processor clock and program continuity (watchdog timer). Any of these errors will cause the ATC unit to send “bad pulse” streams to the connected dispenser’s calculating and indicating device, to trigger an error and abort any active transactions. This has the effect of disallowing any new or current transactions on either side of the dispenser. The ATC display will also show an error at this time. This condition will continue until power of the ATC unit is cycled.

**3.3** The volume at metering conditions, the product temperature and the selected product reference density values can be viewed on the display that is fitted to the ATC unit main board.

**3.4** The temperature sensor cable is connected into the ATC via the IS barrier. A maximum of 4 temperature probes can be connected.

**3.5** The configuration of the calculating and indicating device, and the position of the dipswitches, is given in Figure 4.

#### **3.6 Selectable presentations on the display**

- Volume at metering conditions.
- Measured product temperature.
- Selected reference density.
- Error codes.

### **3.7 Error Messages**

Error message will alternate at 2 second intervals with the information selected by the switches.

Prob = Probe Error

Puls = Pulse Error

Priority of error is as shown above, when both errors are detected, i.e. a Probe and a Pulse error, only “Prob” will be indicated.

When nozzle is activated, the display could show following code:

OFF = ATC Compensation is disabled

Any known defects are detected by the ATC software and a routine shut down occurs. An error signal is sent to the dispenser. Any corruption of software results in the same error signal and shut down.

### **3.8 Software version check**

The software version can be checked by cycling the power to the unit. The software version will be shown for 2 seconds on the ATC display, after this the temperature will be shown.

### **3.9 Securing**

**3.9.1** The ATC enclosure is secured with a seal. After all switches have been set to their correct position, the module’s enclosure shall be sealed against opening.

The enclosure may vary so the figure is an example for guidance purposes.

**3.9.2** The temperature probe is secured, to prevent its removal (Figures 6, 7, 8, 9, 10, & 11).

## **4 CONDITIONS**

**4.1** For dispensers providing temperature compensation, the primary indicator (dispenser display) shall clearly indicate that the volume dispensed is corrected to 15 °C.

**4.2** When this ATC is part of a fuel dispenser or LPG measuring device, the minimum measured quantity of that fuel dispenser, or LPG measuring device, shall be clearly indicated as being 2 litres minimum delivery\*.

\* The minimum delivery level may alternatively be 5 litres.

**4.3** The ATC unit shall be powered from the calculating and indicating device to which it is connected. Under no circumstances should the ATC power supply voltage fall below 5,0 V DC.

**4.4** The temperature sensor cable shall be connected directly to the ATC enclosure.

**4.5** The use of this Supplement Certificate is limited to only those 3<sup>rd</sup> parties who have obtained written permission from Temptronix Inc., Canada.

**4.6** Having the following updated software identified on the Genius ATC kit display during startup.

- ATC SW X.X (where X.X is currently 2.0)
- KER 1.0 D88B0B71

The software is divided into two parts: legally and non-legally relevant. The kernel is the software component where the legally relevant operations are performed, and is identified by the version number (1.0) and associated checksum (D88B0B71).

The non-legally relevant software may be updated which will change the ATC SW identification. However, this will not affect the legally relevant software identification.

**4.7** Having alternative Temperature Probes identified as model W99-3.

**4.8** Having a Fast Install Module (FIM) Board. The FIM may be required for particular dispensers to properly interface the GENIUS ATC with the dispenser electronics. The FIM enclosure is secured with a seal, after all the connections are finalized, to guarantee the integrity of the connections between the pump and the GENIUS ATC kit. Typical examples of installed FIM Boards are shown in Figures 12 and 13. In addition to the FIM, a separate Sealing Box may be used to seal pump connectors to guarantee the integrity of the connections between the pump and Genius ATC kit. An example of an installed Sealing Box is shown in Figure 14.

**5** The identification of the dispenser models which this device may be fitted onto is given in the table below, or this device may be fitted to other models as identified in the particular Type Approval Certificate(s) [TACs].

<b>Certification No.</b>	<b>Dispenser Model identification</b>	<b>Certification No.</b>	<b>Dispenser Model identification</b>
1828/40* <sup>1</sup>	Highline 2	2486/54*	Enterprise, Enterprise 'Dimension Plus'
1918/74*	Highway / Prestige / Pegasus	2536	10,000 series
1940	Series 100, 200 & C	2609 <sup>1</sup>	DPC / DPBA / DPX
1958/53*	Series 8200 / Series 8400 / Series 8700	2616	Quantum ATM
1967/66*	Highline 2	2619/43*	Global Century
2017	MPD 363	2650/35*	SK700
2162/92*	Euroline	2739	DPX A Light
2176/78*	Series 9000 MkII	2780	Euro: 1000 VI R, 2000 VI, 4000C VI, 4000B VI, 4500 VI, 5000 VI
2286/58*	Elite / Euro H (** aka Mobil 94) / Level 5 / Optima / Range 2000, Quantum 500	2805	Alpha
2461/26*	G-line	2806	Merridale Commercial

(\*) Refers to the dispenser model only. \*\* aka ("also known as")

(1) These Certificates have expired, but are quoted as they may be relevant for previous versions of this certificate

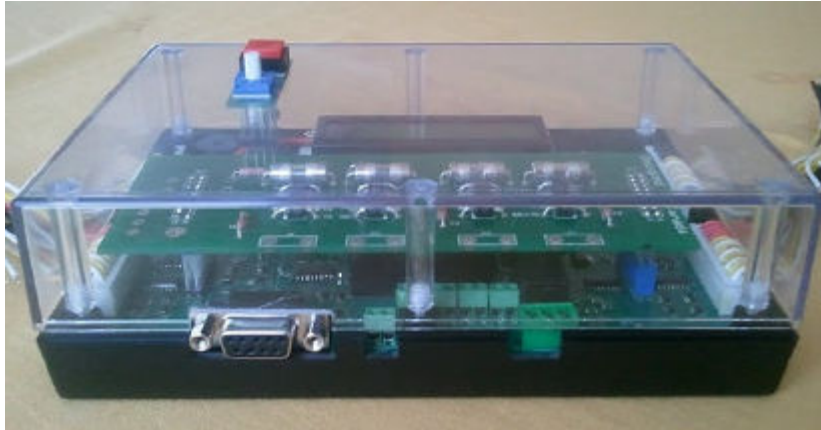
**Table 1 Dispenser Model Identification**

## 6 CERTIFICATE HISTORY

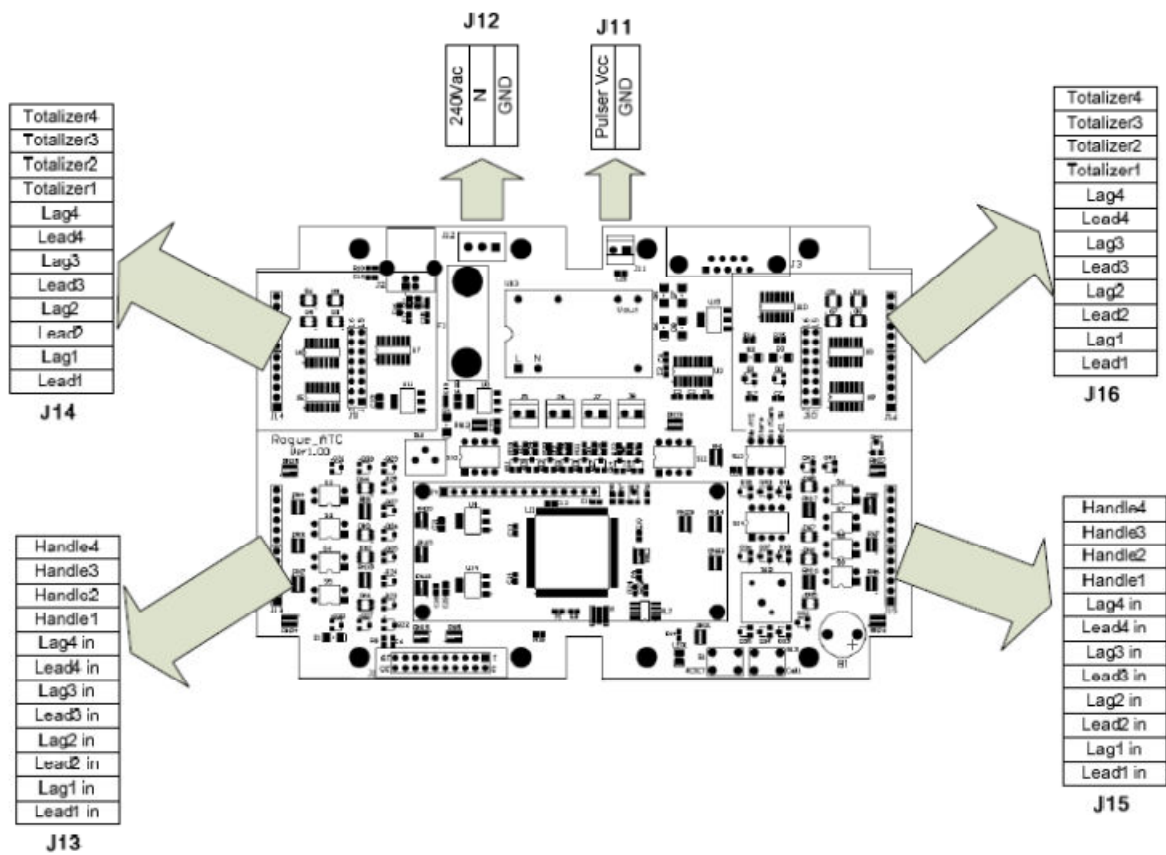
ISSUE NO.	DATE	DESCRIPTION
SUPPLEMENT Series S034	21 November 2011	Certificate first issued
SUPPLEMENT Series S034 Revision 1	27 January 2012	Addition of sections 5 & 6
SUPPLEMENT Series S034 Revision 2	04 October 2012	Amendment to section 4.2 “..shall be clearly indicated as being 5 litres.” is replaced by: “...shall be clearly indicated as being 2 litres minimum delivery*.” * The minimum delivery level may alternatively be 5 litres.
SUPPLEMENT Series S034 Revision 3	19 December 2013	Change of name on front page. Addition of note <sup>(1)</sup> relating to expired Certificates, on front page & page 7 Section 5 Table 1 Addition of sections 4.5 – 4.8 Additional wording added to section 5 “..this device may be fitted to other models.” Additional editorial changes including: Section 2.1 addition of 4 <sup>th</sup> sub indent. Section 2.4.1 “option” of 2 <sup>nd</sup> thermo well. Deletion of 3.7.1, also Heading and numbering changed.
SUPPLEMENT Series S034 Revision 4	16 May 2014	Amendment to: <b>ILLUSTRATIONS.</b> Change to title of figure 6 and addition of new figures 7 - 14. Previous figure 7 and 8 renumbered. Previous Figure 9 deleted <b>2.1.1</b> Function select Position 4 -...“channel” replaced by “grade”. The following text in <b>2.4.1</b> is replaced: “The probe is a type W199-4 ATEX, which is positioned either directly, or via a Thermal Test Well, on the



		<p>discharge side of the pumping unit and located as close as possible to the meter. Examples of probe mounting can be found in Figure 4. An optional second Thermal Test Well may be located adjacent to the probe for use with another temperature sensor, in checking that the probe is operating correctly. Where this second Test Well is fitted, it shall be covered with a plug to prevent dirt entering the Test Well. The W199-4 temperature probe is connected to the IS barrier board.”</p> <p><b>2.5 Conversions</b> Addition of products and product densities.</p> <p><b>3.9.2</b> Amended to include Figures, 7, 8, 9, 10, &amp; 11.</p> <p><b>4.4</b> “box” replaced with “enclosure”. The following text in <b>4.8</b> is replaced: “Having a Fast Install Module (FIM) Board. The FIM may be required for particular dispensers to properly interface Genius ATC with the pump electronics. The FIM enclosure is secured with a seal, after all the connections are finalized, to guarantee the integrity of the connections between the pump and the Genius ATC kit. An example of an installed FIM Board is shown in Figure 9.”</p> <p>Figure 6: image replaced.</p>
--	--	--



**Figure 1 GENIUS ATC and Enclosure**



**Figure 2 Schematic of ATC Main Board, and Connections**

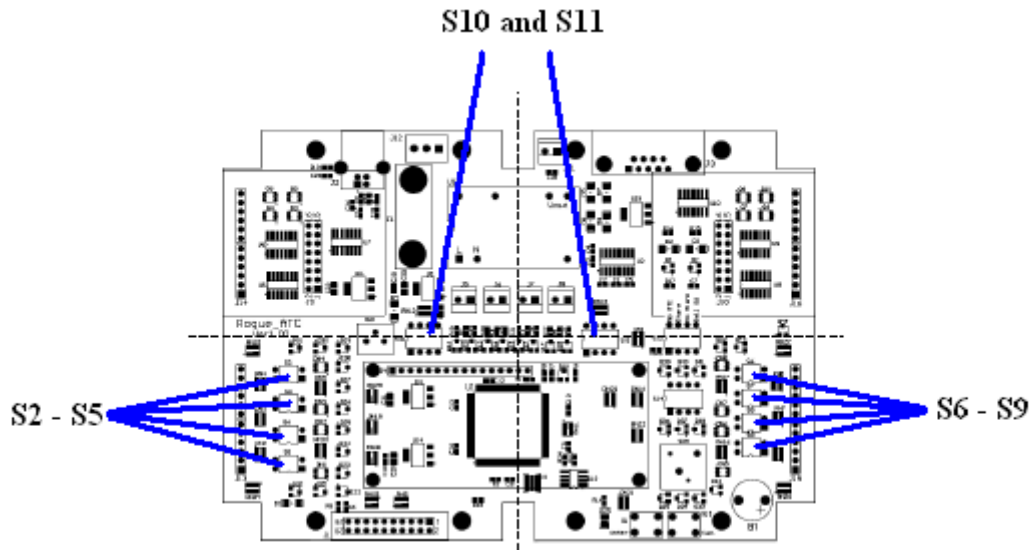
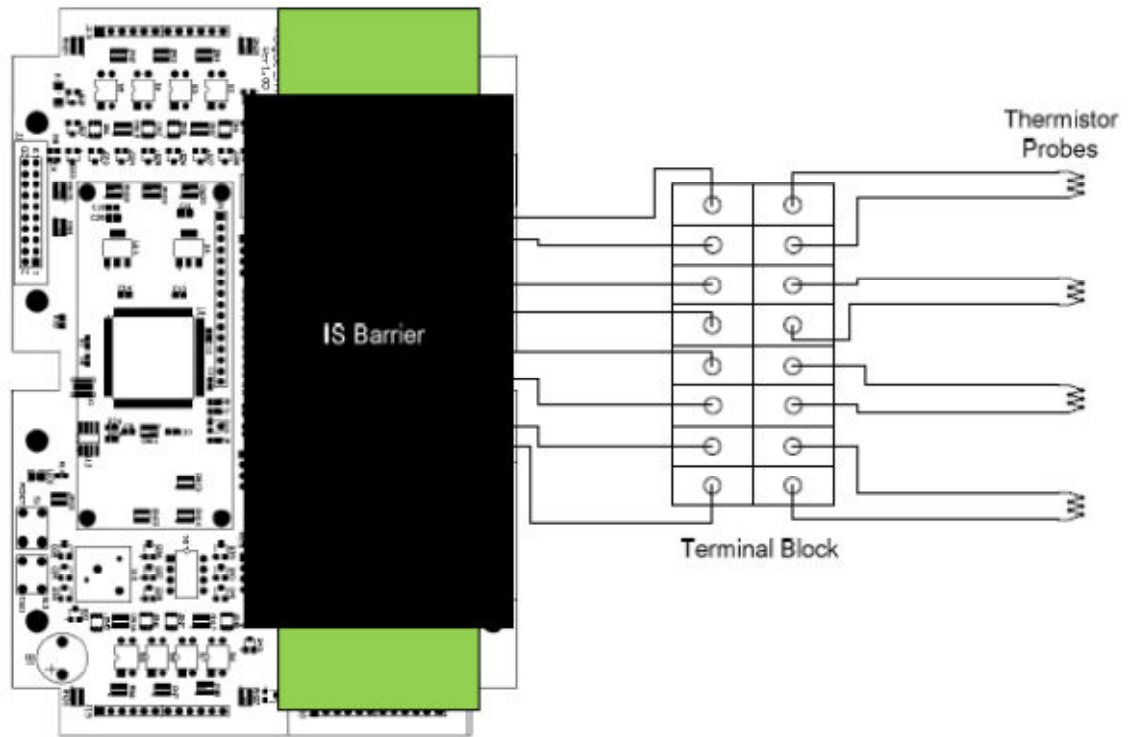


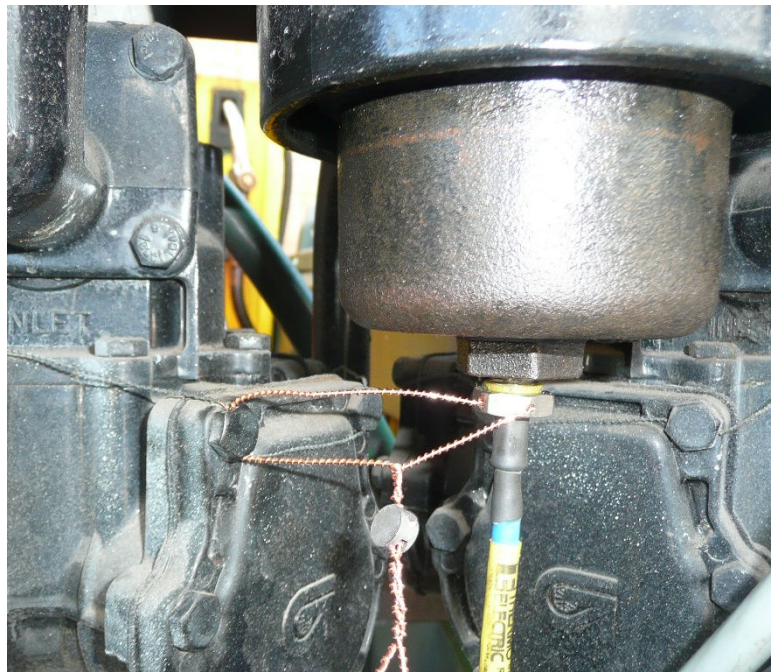
Figure 3 Positions of Dip switches S2 – S5, S6 – S9, S10 and S11

Description	Dip switch	Setting	
Product density selection	S2 ... S9	Switch 1	Switch 2
Product code for product 1		On	On
Product code for product 2		On	Off
Product code for product 3		Off	On
Product code for product 4		Off	Off
K-factor	S10 + S11	Set to appropriate binary k-factor (pulses/litre), as given in the Genius ATC user manual.	
No ATC mode	S12, switch1	Off: ATC is active, pulses will be scaled according to measured temperature On: ATC kit is <b>not</b> active, inlet and outlet pulses will be the same; (to be used for calibration of the dispenser).	

Figure 4 Main ATC Board Settings



**Figure 5 IS Barrier Board and Connections**



**Figure 6 Example Mounting of Temperature Probe**

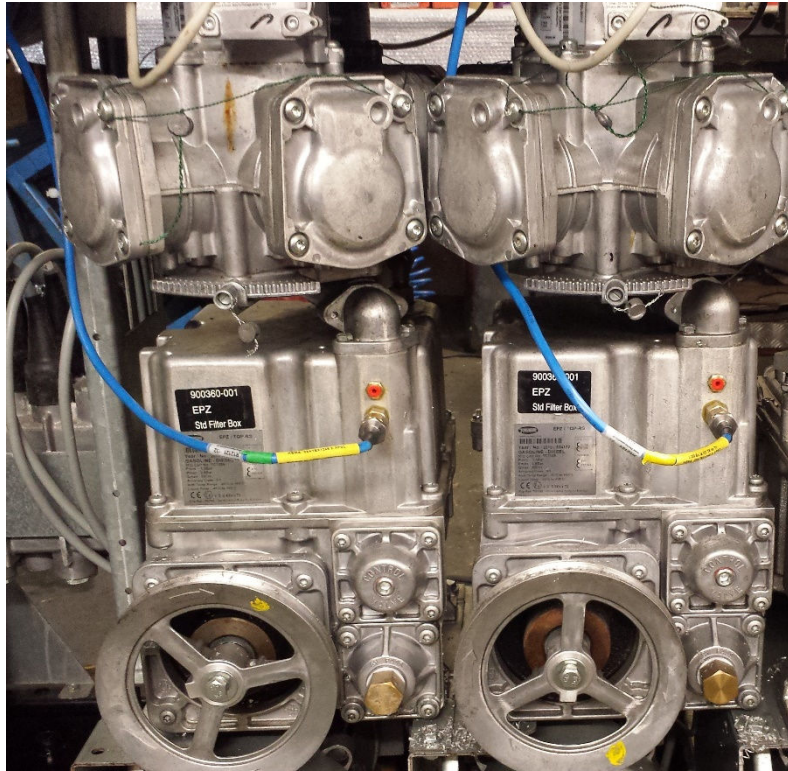




**Figure 7 Example Mounting of Temperature Probe**



**Figure 8 Example Mounting of Temperature Probe**

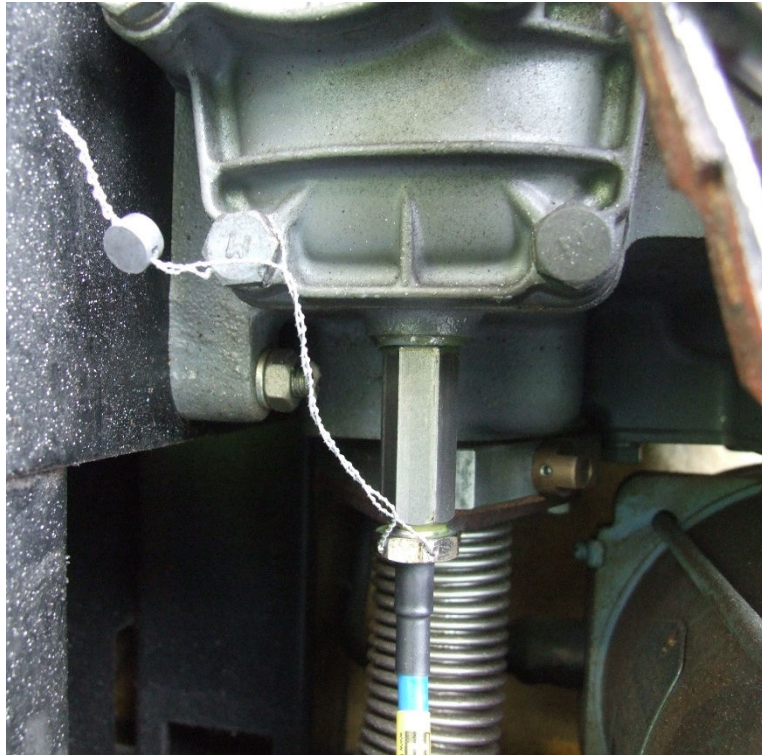


**Figure 9** Example Mounting of Temperature Probe



**Figure 10** Example Mounting of Temperature Probe

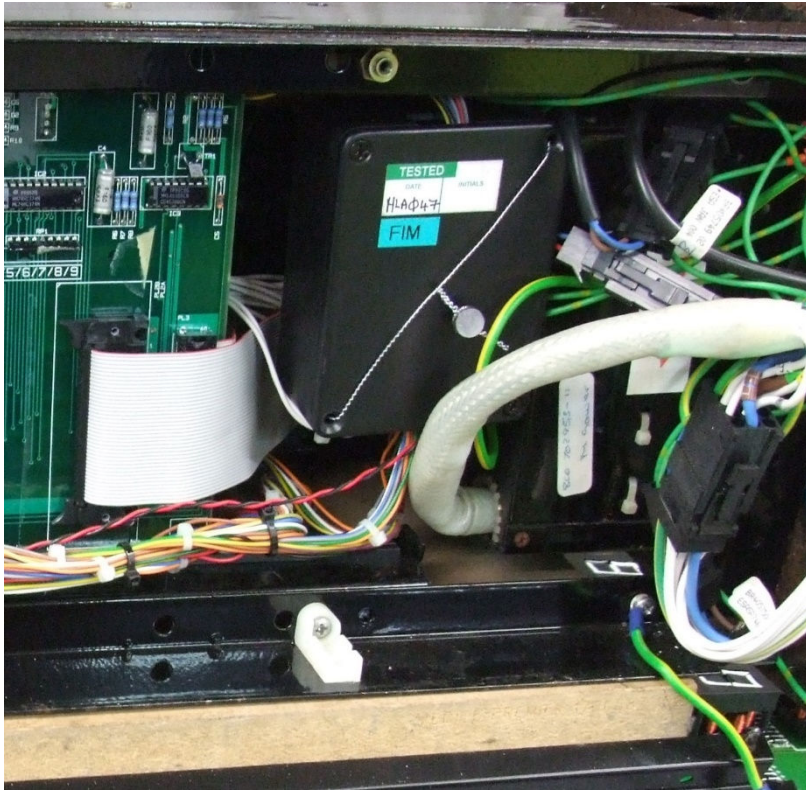




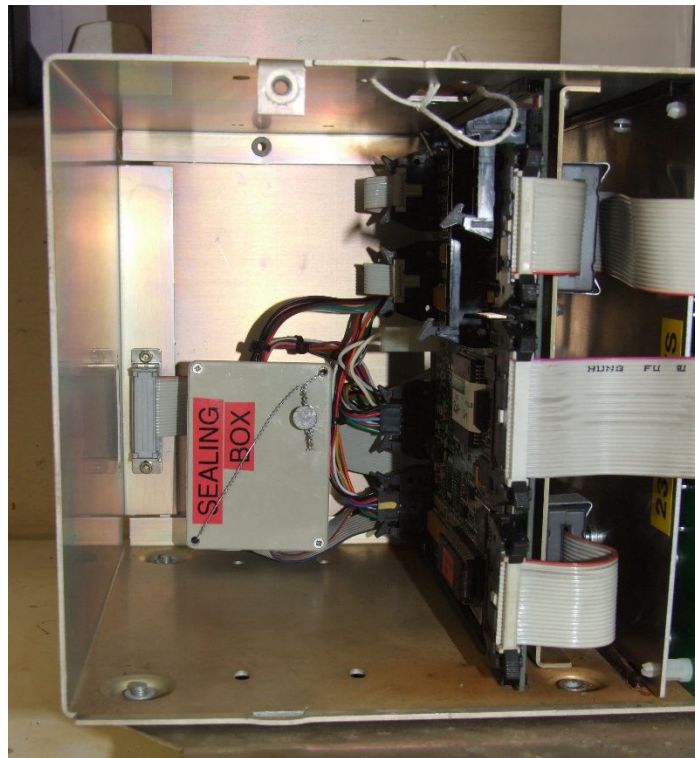
**Figure 11 Example Mounting of Temperature Probe**



**Figure 12 Example of FIM Board**

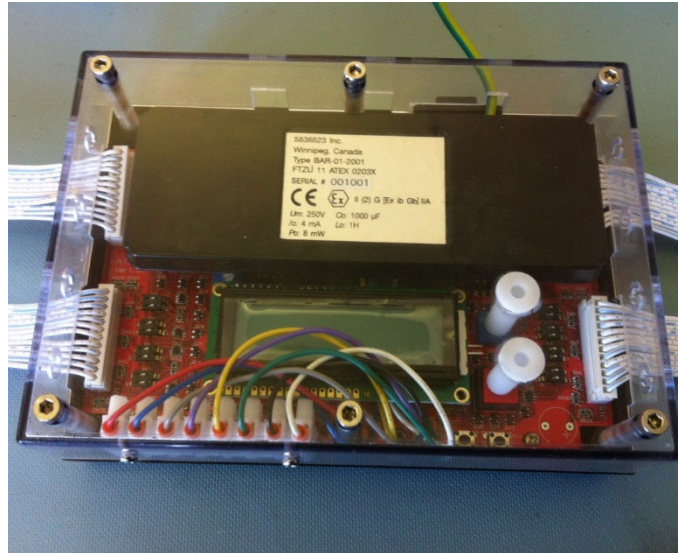


**Figure 13** Example of FIM Board



**Figure 14** Example of Sealing Box





**Figure 15** Example of Alternative GENIUS ATC Enclosure