

Certificate

Pursuant to section 12 of the Weights and Measures Act 1985

Certification No 2619/63 Revision 3

Valid Until 26 October 2016

In accordance with the provisions of section 12 of the Weights and Measures Act 1985, the Secretary of State for Business, Innovation & Skills hereby certifies as suitable for use for trade a pattern of a liquid flowmeter as described in the descriptive annex to this Certificate, and having the following characteristics:-

DISPENSER:	Wayne Global Century dispenser as described in the descriptive annex.
POINT OF SALE SYSTEMS:	As described in the associated certificates 2619/26, 2619/29, 2619/42, 2619/43, 2619/45, 2619/53, 2619/58, 2619/59, 2619/60, 2619/62, 2619/63, 2619/64 and 2619/66.
ATC SYSTEMS:	As described in the associated certificates 2619/61 and 2619/65

Under the provisions of section 12(6) of the said Act, the validity of this certificate is limited as shown above.

This revision replaces previous versions of the certificate.

Note: This certificate relates to the suitability of the equipment for use for trade only in respect of its metrological characteristics. It does not constitute or imply any guarantee as to the safety of the equipment in use for trade or otherwise.

Submitted by: **Wayne Fueling Systems Sweden AB**
Hanögatan 10
211 24 Malmö
Sweden

Issue Date: **15 September 2014**
Reference No: **T1117/0012**



Signatory: **G Stones**
for **Chief Executive**



Descriptive Annex

1 INTRODUCTION

This pattern of an electrically driven flow meter comprises of a dispensing unit operating in attended or stand-alone mode. It is manufactured by Wayne and is designated the Global Century Series. Each dispensing unit is double-sided serving up to two grades of fuel on each side via four metering systems. The transaction data for each side is shown on the display and computing head. The dispenser can indicate up to 9999.99 litres giving an indication every 0.01 litres or 0.001 litres in calibration mode. The price-to-pay indication indicates up to £9999.99 in intervals of £0.01. The unit price increments every 0.1 pence per litre up to a maximum of 999.9 pence per litre.

Up to two unit prices may be shown on each side of the dispenser, one for each grade. Any of the two grades of fuel can be delivered from each side of the dispenser but only one nozzle per side can be used at any one time.

This pattern is suitable for liquids other than water of low viscosity (<20mPa.s) except liquefied gases. This includes ethanol blends up to 100% ethanol.

2 CONSTRUCTION

2.1 Mechanical

The dispensing unit consists of a hydraulics enclosure, support columns and an electronic computing and display head attached to the support columns. Structural assemblies and panel work are constructed in mild steel (Figure 1).

Access to the hydraulics is made by unlocking the hydraulic enclosure panels.

2.2 Hydraulics

The hydraulic unit is designated the Global Hydraulic Module and comprises of a motor driven pumping unit, with integral air separator, feeding two meters, with associated non-return and pressure relief valves. The meter output pipes are routed via solenoid valves and pipes to the hose supports. There can be up to two such hydraulic arrangements per dispenser (Figure 2).

Alternatively the fuel can be supplied to the dispenser unit by a submersible turbine pump (STP), in which case motors, pumping units and air separators are not fitted. A check valve is fitted at each of the meters in the dispensing unit and a solenoid valve is fitted. The storage tanks from which the STP delivers the product shall be equipped with a level detection device. The level detection device is connected to the system to prevent the pumping unit from operating when a low level is detected.

2.2.1 Combined pump and air separator (Pattern Designation: 172441)

The pumping unit manufactured by Wayne is belt driven from an electric motor and has an integral air separator.

2.2.2 Duplex meter (Pattern Designation: 167310)

It is manufactured by Wayne and has two meters within the one casting (Figure 3). Calibration of the meter is carried out electronically

2.2.3 Pipework

A pipe from each meter is routed via a solenoid valve to fixing points on the enclosure to which the flexible hose is attached, the hose terminating in a nozzle. Nozzles are stowed in holsters along the sides of the hydraulics enclosure.

2.2.4 Solenoid valve

A solenoid valve is fitted on the discharge port of each meter. When energised the valve allows full flow of the liquid.

2.2.5 Nozzles

The following nozzles may be used:

Manufacturer	Model/Description	Type
Elaflex	ZVA 4.4R for use with unleaded petrol	Automatic Shut-off
Elaflex	ZVA 4.4 for use with leaded petrol and diesel	Automatic Shut-off
Elaflex	ZVA 25.41 high flow nozzle for diesel	Automatic Shut-off
Elaflex	ZVA Slimline Drip Stop nozzle Minimum Delivery 5 litres. (Where the dispenser is marked with minimum delivery of 2 litres, a legend indicating a 5 litres minimum delivery will be marked on the spout of the nozzle, this marking overrides that marked on the dispenser).	Automatic Shut-off
Elaflex	ZVA Slimline 2	Automatic Shut-off
Elaflex	ZVA X204 GRV3G for use with unleaded petrol	Vapour Recovery
Elaflex	ZVA X204 GRV3R-BL for use with leaded petrol	Vapour Recovery
Elaflex	ZVA X204M GRVP	Vapour Recovery
Elaflex	ZVA Slimline 2 GR	Vapour Recovery
Husky	Type 'X' series, single and double poppet designs. Optional accessories including swivel joints, sight glass option, and alternative spouts and splash guards which may be fitted as required.	Automatic Shut-off
Goodyear	GTR 50 for flowrates up to 50 litres /minute	Automatic Shut-off
Goodyear	GTR 80 for flowrates up to 80 litres /minute	Automatic Shut-off
Goodyear	GTR 120 for flowrates up to 120 litres /minute	Automatic Shut-off
Goodyear	GTR 50 VR	Vapour Recovery
OPW	11 VAIE-0035 for use with unleaded petrol 11 VAIE-0037 is for leaded fuel.	Vapour Recovery

OPW	11 VAIE-0037 for use with leaded petrol	Vapour Recovery
OPW	12 EN (may be fitted with different sizes of spout depending on the product type)	Automatic Shut-off
OPW	12 EN V (may be fitted with different sizes of spout depending on the product type)	Vapour Recovery
ABR	ABR 50 VR	Vapour Recovery

2.2.6 Hoses

The following hoses may be used:

Manufacturer	Model	Maximum length (Metres)
Elaflex, Germany	Conti – Slimline 25 Low temperature	6
Elaflex, Germany	Conti – Slimline 21 Low temperature	10
Elaflex, Germany	Conti – Slimline 16 Low temperature	13
Elaflex, Germany	Conti – Slimline 21 MPD	7
Good Year, USA	EN1360 TYPE 3 25mm 16 BAR M 1Q00 0310	15
Good Year, USA	EN1360 TYPE 3 16mm 16 BAR M 1Q99 0749	15
Good Year, USA	¾" Hardwall Petrol Hose	15

2.3 Electrical

2.3.1 Motor

The motors that drive the rotary pumps are single-phase or 3 phase, 1 HP rated.

2.4 Electronics

2.4.1 Pulser Pattern Designation: 165560 (WM001682-0001)

The Wayne Integrated pulser (WIP) contains the electronics of two conventional pulsers (Figure 4). It is fitted to the top casting of the Wayne Duplex meter.

As there is no facility for mechanically adjusting the meter, the calibration is done electrically. To calibrate the pulser, a magnet has to be removed from the pulser enclosure via a hinged cover. The magnets are situated in the pulser housing and are removed by first removing the seal and then opening the door thus exposing the magnet. A test measure is then taken and the magnet is returned to its normal position.

2.4.2 Indicating device and calculator

2.4.2.1 Display head (Figure 5)

The display head is supported from the column and contains the electronic computer, displays, power supply and motor switching circuits known as the iGEM electronics package. These are all housed in the electronics enclosure with a window in each side. Illumination is by fluorescent tube.

2.4.2.2 Computer board (Figure 6) (Pattern Designation: 168862)

This board contains central processor unit (CPU), all the input/output ports and the dispenser memory. The memory is retained if there is a power failure by means of a battery back-up facility. Any of these alternative CPU boards with the following designations may be fitted:

WM001908-0001

WM001908-0002

WM001908-0005

2.4.2.3 Display board (Figure 7) (Pattern Designation: 168855)

The dispensing unit can contains four display boards, up to two on each side of the computing and display head, depending on hose, configuration or display requirements. The board contains liquid crystal display elements to display price-to-pay (6 digit), volume (6 digit), pence per litre (4 digit).

2.4.2.4 ISB board (Figure 8) (Pattern Designation: 165561)

This is an interface board connected between the pulser and the pump computer board and is an intrinsically safe barrier. Alternatively ISB board, pattern designation 173950 (WM002450) may be used.

2.4.2.5 Power supply unit (Figure 9) (Pattern Designation: 403064, 403065)

This is manufactured by Omron and is a switch mode type rated at 24Vdc 50 Watt (100 Watt optional). The following alternatives may also be used:

Manufacturer	Part Number
APS	APS65ID-S240025
APS	RL0211E15-24A
Channel Well	UAS150B
Powerbox	PBSE1071 Rev 1, 150W max

2.4.2.6 Power distribution board (Figure 10) Identification No: 61-53193/01

This board contains the relays for controlling up to four pump motors and a vapour recovery motor and isolation relays for the data and audio signal lines. It also has connectors for distributing power to optional equipment.

2.4.2.7 Power Connection Board Identification No. WM025501-XXXX (depending on options fitted).

This board contains options for power connections, integrated mains switches & fuses, serial communication/interface with lightning protection, heater thermostat and relays for submersible pumps.

2.4.3 Communication protocol

Communication to the self-service system may be current loop, RS485 or IFSF-LON.

An optional 'wireless' communication interface for data collection purposes may be connected. By using standard off the shelf components, an 802.11b wireless 2.4GHz Ethernet network to provide a link between the pump and kiosk that gathers pump diagnostics and performance indications.

2.5 Displays and legends

The legends and displays on the computing and display head are shown in Figure 5 and set out as follow:

Legend	Associated display	Approximate height
THIS SALE £	XXXX.XX	13 mm 8 mm (some Ovation enclosures) 25mm
MINIMUM DELIVERY 2 LITRES*		5 mm 3 mm (some Ovation enclosures)
LITRES	XXXX.XX	13 mm 8 mm (some Ovation enclosures) 25 mm
PENCE PER LITRE	XXX.X	5 mm 3 mm (some Ovation enclosures) 12 mm
WAYNE		3.5 mm

*The minimum delivery legend may alternatively be 5 litres

There are displays on both sides of the display head. Indications of price-to-pay, volume and unit price are arranged one below the other and are of the 7-segment liquid crystal type. There may be up to two unit prices displayed which will be identified by colour coding and/or a written description of the grade adjacent to the unit price window. The same colour coding/written description will identify the nozzle holster and may also identify the hose and nozzle boot. Providing there is no sale in operation and a nozzle is removed then all the displays will show all '8's, all 'blanks', all 'zeros' then '0.00'. The unit price windows then all go blank except the grade selected and the sale can commence. Once the nozzle is replaced, after 5 to 8 seconds all the unit prices are restored.

2.5.1 Alternative Display Boards

The iGem electronics can be fitted with alternative display boards as listed in the table below:

Display Board Description	Manufacturer	Part Number
Double Row, 1 Unit Price	NOTE Lund AB	WM010887-0001
Double Row, 2 Unit Prices	NOTE Lund AB	WM010888-0001
Double Row, 3 Unit Prices	NOTE Lund AB	WM010887-0002
Double Row, 4 Unit Prices	NOTE Lund AB	WM010888-0002
Double Row, up to 4 Unit Prices	NOTE Lund AB	WM023035-XXXX, depending on number of unit price displays

2.6 Sealing

2.6.1 Meter and pulser (Figures 3 and 4)

Each pulser is sealed to the meter body by passing a wire through a hole in each pulser door and an adjacent hole in the meter casting then into the seals. The meter is sealed by sealing wire being passed through two screws on a cylinder head, then through two screws on the adjacent cylinder head and then into a seal. The same sealing is done on the other side of the meter.

Note: Some dispensers may have a factory fitted sealing wire between the meter and the dispenser frame. This approval does not require this seal to be in place.

3 OPERATION

3.1 Operating sequence

At the start of the transaction, the dispenser displays the previous sale. The operator removes the nozzle corresponding to the grade required on the side of the dispenser at which he is standing. The displays show all `8's, all `blanks', all `zeros' then `0.00'. The unit price corresponding to the nozzle removed is displayed, the other unit prices will blank, and the appropriate motor is started permitting a delivery to commence.

A second nozzle may be used on the other side of the dispensing unit.

At the end of the delivery the nozzle is replaced in the nozzle holster and the pump motor stops.

3.2 Controls and features

On the underside of the computing and display head are two groups of switches and the Electro-mechanical totes if fitted. They are exposed when the door underneath the pump display head is removed. The group of two rocker switches situated towards the centre are for isolating the mains and data lines and are operated periodically by authorised engineers for maintenance purposes and configuration of the dispenser. The down load socket is for the connection of diagnostic equipment and for down loading the dispenser software. The infrared switch enables the dispenser to be

programmed from an infrared remote control. This allows entry into the pump's parameters, commonly used ones are listed below:

- (a) The setting of pump parameters
- (b) Clearing of totals
- (c) Entry to pump diagnostics
- (d) Setting of pump number, hose grade numbers
- (e) Attendant/self service modes
- (f) Setting unit prices (attendant mode only)
- (g) Dispensed volume limits, per hose
- (h) A third decimal place (one thousandth of a litre) is shown on the volume display.
- (i) Pressing button 7 on the I/R controller during a delivery causes the flow rate for that product to be shown on the unit price display.

3.3 Interlocks and security features

- (a) No price changes can take place during a delivery or until 5 seconds after the nozzle has been replaced.
- (b) A transaction cannot be initiated when the dispenser is in the price setting mode or until a delay of 5 seconds has elapsed after a new unit price has been set at the kiosk.
- (c) A maximum volume limit can be set between 10 and 990 Litres for each hose.
- (d) A maximum money limit can be set between £10 and £990.00.
- (e) A maximum duration of sale can be set between 1 and 30 minutes.
- (f) An anti-fraud timer set between 0.5 min and 5 min checks that if the pump motor is running, the pulser is giving an output. The motor will be stopped if there are no output pulses from the pulser in the set time.
- (g) If the electronics or software detect a significant fault then the pump will stop. If there are three consecutive significant faults then the pump will not be allowed to start.
- (h) There is a 30 seconds delay between a post payment sale and the next sale on that pump.
- (i) Only one nozzle per side may be used at any one time.
- (j) A new sale cannot be started until a guard time of at least 5 seconds has elapsed since the previous sale.

3.4 Software

3.4.1 The legal metrology part of the software has its own checksum. The checksum number is 0bE5 and can be displayed on the volume display by pressing the CRC button on the computer board or operating the IR enable switch where fitted.

3.4.2 Having alternative software checksum number of 555F.

4 AUTHORISED ALTERNATIVES

4.1 Alternative Enclosure Arrangements

4.1.1 Having the dispensing unit described in the certificate, with one or up to a maximum of four, hose(s) and associated nozzle(s). The hose arrangement may be with an equal or unequal number of hoses on each side.

4.1.2 Having nozzles and displays fitted to one side of the dispenser only, in which case the appropriate meters, encoders and valves are removed from the unit and that side of the display case is blanked.

4.1.3 Having only the selected unit price display on the dial face. In this case only the unit price pertaining to the nozzle selected will be shown. The unit price will also be marked for each product near to the nozzle holster from which it will be dispensed.

4.1.4 The volume, price, and unit price displays may be illuminated from the front or rear.

4.2 Alternative Enclosure Styles

4.2.1 Global Star H, Global Star HH, Global Star LHR, Global Vista and The EPT 390 (Figures 11 to 15)

Each of these dispenser enclosure styles is double sided serving up to four grades of fuel on each side via eight metering systems. Each side has a display panel showing transaction data for that side. Up to four unit prices may be shown on each side of the dispenser, one for each grade. Any grade fuel can be delivered from each side of the dispenser but only one nozzle per side can be used at any one time.

The Global Star HH has a high hang hose system. The Global Star LHR has a Low Hose Retract system. The Global Vista has a high hang hose system. These enclosures have internal framework made from aluminium alloys and sheet metal.

4.2.2 EPT 390 (600) (Figure 16)

The EPT 390 '600' version has only one hose and display per side.

4.2.3 Global Ovation (Figure 17)

The dispenser enclosure is double sided serving up to four grades of fuel on each side via eight metering systems. The exterior panels are made from plastic materials and the internal framework from aluminium-zinc alloys and sheet metal. On each side, it has two separate display boards, one for unit price (Figure 18 part number WM021316-0001) and one for sales/volume (Figure 19 part number 887979).

4.2.4 Helix™ fuel dispenser series (Figure 39)

The dispenser enclosure is double sided or single sided serving up to four grades of fuel on each side via eight metering systems. The exterior panels are made from plastic, aluminium and sheet metal materials and the internal framework from aluminium-zinc alloys, sheet metal and steel. On each side, it has separate display boards, one for unit prices (part number Wayne WM039738) and one or two on each side for sales/volume (part number Wayne WM039224-0001). An alternative intrinsically safe barrier (part number Wayne WU004200-0001 or -0002) and an optional incorporated Media screen, credit card reader, pin-pad, and receipt printer with associated electronics.

4.2.5 Global Star H With Fuel Grade Selection Function (Figure 40)

Having the Global Star H dispenser as described in section 4.2 amended with the possibility to have one single hose/nozzle for 3 different gasoline grades and/or one single hose/nozzle for 2 different diesel grades. It will also use the same sales and volume display as used in the Helix dispenser which is described in section 4.2.4. Under the display head there will be a grade selection box for the end user to select the grade.

4.2.5.1 Conditions

Approval of the configuration specified in 4.2.5 above is subject to the following conditions:

- 1. The dispenser shall not be configured to dispense different types of fuel from a single hose/nozzle.**
- 2. The minimum delivery or MMQ stated on the dial face shall be equivalent to at least 10 times the volume of fuel held in the pipework/hose.**

4.3 Alternative meter type 'X-Flo'

4.3.1 X-Flo modules

4.3.1.1 There are two versions of the X-Flo module; suction unit and remote unit. The remote unit is used when fuel is supplied to the dispenser by a submersible turbine pump (STP) while the suction unit is used when the dispenser incorporates the motor and pump. The remote and suction units are shown in Figures 20 and 21 respectively. The pump cover, remote inlet and the dome cover are different on the two versions.

4.3.1.2 The meter housing consists of two independent metering units, with the two sides designated Side A and Side B. The meter can be Single (Side A or Side B) or Duplex. The X-Flo meter has an approved flowrate range of 3 - 80 litres/min, and a minimum measured quantity of 2 litres.

4.3.1.3 In each meter, one pair of spindles is provided, thus giving two pairs per meter housing. The pair of spindles consists of one long (male) and one short (female) spindle. The female spindle has three entrances while the male spindle only has two. This allows the transfer of fuel through the meter housing. Each revolution gives 1.1 cl, thus there are approximately 88 revolutions per litre. The longer spindle is provided with a stud which incorporates a magnetic ring. The ring is magnetised with 3 north pole faces and 3 south pole faces evenly distributed along the outer circumference.

4.3.2 Pulse transmitter

4.3.2.1 The pulser is a type X-WIP (Wayne WM011529-0001) which is mounted on the dome cover of the meter. A circuit board is equipped with one dual Hall-effect sensor for each measuring element. This board is placed outside the rotating spindle housing so that the dual Hall-effect sensors sense the rotation of the measuring element. When the measuring element rotates a change corresponding to 0.19 cl can be registered.

4.3.2.2 A microprocessor on the circuit board reads the changes from the dual sensor and calculates the volume through the meter elements. The microprocessor communicates with the pump CPU to calculate the measured volume and to facilitate troubleshooting and diagnostics.

4.3.2.3 Having the alternative pulser type X-WIP II (WM019142-0001). Functionality is as described for X-WIP pulser.

4.3.3 Calibration

4.3.3.1 There are two calibration switches on the printed circuit board of the pulser that are used to set the pulser processor into the calibration mode.

4.3.3.2 Next to the calibration switches described above are two magnets, one for each meter element. To calibrate the pulser the appropriate magnet is moved away from the calibration switches. The magnet is located behind a cover which is opened to reveal the magnet. The microprocessor detects that the magnet has been removed and resets itself in calibration mode. In calibration mode a characteristic curve is downloaded to the meter. A test measure is taken and the magnet is returned to its normal position.

4.3.4 Securing (Figure 37)

4.3.4.1 The meter is sealed by running a sealing wire through one screw between the dome cover and the meter housing and one screw between the pump cover and the meter housing.

4.3.4.2 The support plate on the pump cover is sealed by running a sealing wire through one screw in the support plate and one screw between the pump cover and the meter.

Note: Some dispensers may have a factory fitted sealing wire between the meter and the motor chassis. This approval does not require this seal to be in place.

4.3.4.3 The X-WIP calibration covers are sealed by running a sealing wire through the sealing hole in each calibration cover and the corresponding sealing hole in the dome cover and around the X-WIP back to the hole in the dome cover.

4.3.4.4 Alternative sealing method (Figure 38)

The sealing point on the screw between the pump cover and the meter housing is omitted. Instead the sealing wire on the screw holding the dome cover and the meter housing is passed through a screw on the pump cover. This allows the meter housing to be separated from the pumping unit in order to replace the filter.

4.4 Alternative Minimum Delivery of 5 Litres

All of the configurations and enclosure styles described in this certificate (**except that described in section 4.2.5 Global Star H With Fuel Grade Selection Function**) may have a minimum delivery of 5 litres.

4.5 Alternative sealing methods

The Electronic head and hydraulics may be alternatively sealed as shown in figures 41 and 42 respectively.

5 STAGE II VAPOUR RECOVERY

The following stage II vapour recovery devices may be installed on the dispenser:

5.1 Wayne ‘Burkert’ assisted vapour recovery system with or without Vapour Gate System

5.1.1 Description

The Wayne ‘Burkert’ assisted vapour recovery system is shown in Figure 22 with the Vapour Gate Meter. A vacuum pump supplies vapour recovery for each grade of fuel. In one dispenser there may be grades with or without vapour recovery. The rate of vapour recovery is controlled by independent electronics that adjusts, using a pulse drive output, the vapour flow according to the fluid flow. Vapour recovery continues for a short period after the nozzle has been stowed.

5.1.2 Construction

The existing hose is replaced by a co-axial hose with the vapour line converted at the upper flexible to affixed connection to small bore copper pipe. This pipe is taken via a proportional control valve to an independent electrically driven vacuum pump. The nozzle is replaced with a nozzle having a vapour annulus and an additional mechanism connected to the fluid flow valve that shuts the vapour line at the same time as the fluid flow. Recovered vapour is returned to the supply tank independent of the dispenser hydraulics. The following components are used in the Burkert vapour recovery system:

- | | |
|-----------------------------|--|
| a) Hose: | Elaflex Conti Slimline 21 |
| b) Vapour recovery nozzles: | Any compatible vapour recovery nozzle |
| c) Motor: | Elnor type BA240CP11-AR-R |
| d) Vacuum pump types: | Gardner Denver Thomas types 8014-5.0, or |

	8014-6.0
	Or Dürr types MEX 0831-10, MEX 0831-11 or MEX 0544
e) Proportional valve:	Burkert type 6022
f) Control board:	Burkert 147911
g) Break coupling:	Elaflex CSB 21

Parts c, d, and e are situated in the hydraulics enclosure and part f is situated in the display head.

5.1.3 Vapour Gate System

The meter measures the gas volume that passes through the vapour recovery system. The meter is an oscillating type of gas meter, a small amount of gas passes through the meter and is made to oscillate as it passes a thin heated platinum wire. This creates a frequency that is proportional to the gas flow. The ISB/interface transforms this frequency to pulses that iGEM calculate in to a volume. A ratio, referred later to as A/L, is calculated by dividing the amount of gas volume recovered with the amount of liquid dispensed. This ratio is allowed to be $0.85 \geq A/L \geq 1.15$, otherwise the filling is considered as erroneous.

A second path can be installed between the nozzle/nozzles and the VR meter that is controlled by an on/off valve. During normal circumstances this valve will be closed. Every filling is evaluated by iGEM and if fillings start to be out of the normal characteristics, according to certain parameters, the system will perform a self check just after the filling has ended. iGEM simulates a short filling during the self check and the on/off valve is opened to obtain a known and controlled pressure. If the A/L value from the self check is a certain amount higher than the A/L value from the filling, iGEM will consider the filling erroneous even if the measured A/L value is within range. This test is used to detect if any of the nozzles has a jammed suction path in the vapour channels.

If the system has ten fillings on the same side out of range, ten unapproved self checks on the same nozzle or a combination of both, it will start a timer, if after 168 hours has elapsed it will close down the side until the error is reset.

6 VOLUME CONVERSION DEVICES

6.1 TVC volume conversion device (Temperature compensation device)

6.1.1 System Description

The TVC is a conversion device for use with two meters, intended for correcting volumes of fuel as if dispensed at 15°C. The temperature compensation function is added by connecting the TVC unit between the pulse output of the dispenser pulser and dispenser calculator. The TVC provides a pulse output stream corrected for temperature by monitoring the temperature of the fluid passing through the meter. The pulse output is no longer a fixed number of pulses per rotation of the meter output shaft, but adjusts the volume of fuel as if it is dispensed at 15°C. The TVC unit is shown in figure 23.

The conversion calculation for a certain density of fuel is determined by the selection of a suitable density block (module) as shown in figure 25. The density block contains the calculations as specified in the ASTM manual D1250-80, table 4. The density blocks are identified as follows:

Module identification	Density range in kg/m ³
B1	720 - 730
B2	730 - 740
B3	740 - 750
B4	750 - 760
B5	760 - 770
B6	770 - 780
D1	810 - 820
D2	820 - 830
D3	830 - 840
D4	850 - 860

6.1.2 Construction

6.1.2.1 TVC unit

The TVC circuit board is housed in a secure box which prevents unauthorised access to the calibration button and the power supply, data link, temperature sensor, density block and pulser connections. The box has a clear lid to allow inspection of the density block.

Optionally an LCD display (figure 24) may be installed which allows access to the following data by pressing the scroll button:

- Fixed Density
- Temperature (Actual temperature from liquid)
- Uncompensated volume 1(last delivery, 2 digits behind the comma)
- Uncompensated volume 2(last delivery, 2 digits behind the comma)
- When test button is pressed, display shows "bypass"
- Display shows "ERROR" when the TVC is defective or errors occur

6.1.2.2 Temperature sensor

A temperature sensor manufactured by E. Meurs BV and designated LM335 is connected to the TVC unit. The temperature sensor (figure 26) is installed in the fuel delivery pipe within one metre from the flow meter; a typical installation is shown in figure 27.

6.1.2.3 Software

An infrared port in the TVC unit allows the reading of data and performing the calibration via an infra red reader connected to a portable PC running the Windows based software 'Fuel Monitor', produced by E. Meurs BV. A typical data display is shown in figure 30

The software version number is: V1.01 and can be accessed with the 'Fuel Monitor' software, or by viewing the LCD screen in the TVC unit where fitted.

6.1.2.4 Indication of measurement result

A legend shall be affixed adjacent to the volume indication clearly indicating that the volume dispensed is corrected to 15 °C.

6.1.3 Adjustments

Adjustments to the calibration and temperature compensation of the TVC unit may be made using a PC having an infra red link and running 'Fuel Monitor' software or using the scroll buttons if the TVC unit has an LCD display.

6.1.4 Sealing

6.1.4.1 The TVC unit is sealed as shown in figure 28.

6.1.4.2 The temperature sensor is secured to prevent removal from the T-connector and the T-connector from the fuel pipe by routing a sealing wire through the sensor and around the pipe connection (figure 29).

6.1.6 Recommended tests

Check that the correct software version is installed in the TVC unit

6.2 Wayne ATC (Automatic Temperature Compensation)

6.2.1 System Description

The ATC system compensates for temperature effects on the measured volume, thus the temperature compensated volume correspond to the product volume at 15 °C. The volume conversion factor, VCF, which is the quotient between the uncompensated and the compensated volume is calculated, and used to do the compensation.

The VCF is based on three quantities; product type; product density; and product temperature. Product type and product density are entered in the ATC setup and the system reads the momentary product temperature and calculates the VCF. The compensated volume is used for the normal transaction data i.e. showed on the display. Both net volumes (compensated) and gross volumes (uncompensated) are saved in the pump computer.

6.2.2 Construction and Installation (Figures 31 and 32)

The ATC system is consists of:

- A Temperature module
- Up to ten temperature probes (depending on pump model)
- An ISB with integrated TTL/CAN converter. (Figure 33)

The system is interfaced to iGem via the CAN-Bus connector, J13 on the iGem board. The specific components and part numbers are shown in the following table:

Part	Part Number	Quantity	Location
ATC dome cover	WM019762 or WM020020	1 per meter hydraulics	Mounted on the meter hydraulics
Temperature probes	WM019643	1 to 10 depending on pump model	ATC dome cover
Temperature Module(composed of several subparts)	WM017626-0001	1	Mounted on the electrical junction box support.
ISB with integrated TTL/CAN converter	WM019881-0001	1	Mounted in the electronic head
Cable interconnecting ISB and TM(2x3circuits)	WM019837-0001	1	
Cable interconnecting iGem to the ISB	WM019845-0001	1	

6.2.2.1 Temperature probes (Figure 34)

One or two temperature probes are mounted per dome cover depending on the pump model (single or double side). If one temperature probe is installed, a blind plug is fitted in the other probe thread. The temperature probes are connected to the connectors on the temperature module board (numbered J2 to J11).

6.2.3 Sealing

6.2.3.1 The Temperature Module (TM)

The sheet metal cover, covering the TM prevents access to the temperature probe connectors. It also prevents access to the switch, which enables access to ATC set up mode. This cover is sealed by a sealing thread, see figure 35

6.2.3.2 Temperature Probes

The temperature probes are sealed pair wise by a sealing thread, see figure 36. If the pump is single sided the probe is sealed in the blind plug.

6.2.4 Conditions

For dispensers providing temperature compensation, the primary indicator (dispenser display) shall clearly indicate that the volume dispensed is corrected to 15 °C.

7 CONNECTION TO MID APPROVED FUEL DISPENSERS AND SELF-SERVICE DEVICE SYSTEMS

7.1 Self-Service Devices

The dispensers in this approval may be connected to any compatible MID POS having an EC Parts Certificate and the following compatible MID POS having the EC Evaluation certificates:

Wayne Fusion -	Evaluation certificate No 107024
iX pay -	Evaluation certificate No 107023

7.2 Fuel Dispensers

The dispensers may be used in a system which also includes dispenser models described in this certificate but which have been conformity assessed in accordance with The Measuring Instruments (Liquid Fuel and Lubricants) Regulations 2006 (SI 2006 No 1266) which implement the Measuring Instruments Directive (2004/22/EC). These dispensers may be as described in the following MID EC type-examination certificates:

- **0402-MID -10 70 21** covers the Global Century/Star range shown in Figures 1, 11, 12 and 13 of this certificate
- **TCM 141/07 -4548** covers the dispensers listed in 0402-MID -10 70 21 but fitted with ATC as described in section 6.2 this certificate
- **T10085** covers the Global Ovation range shown in Figure 17 of this certificate.
- **0402-MID-10 70 26** cover the Helix™ fuel dispenser series shown in Figure 39 of this certificate

8 CONNECTION TO UK NATIONAL APPROVED POINT OF SALES SYSTEMS

The valid until date of 26 October 2016 applies to the following point of sales approvals:

2619/26 - Torex Arciris IRIDIUM combined kiosk control and point of sale system
2619/29 - Wincor Nixdorf kiosk control and point of sale system
2619/42 – HTEC Hydra-U Site Controller
2619/43 - HTEC HydraPos combined kiosk control and point of sale system
2619/45 - BP Global Site System combined kiosk control and point of sale solution
2619/53 - Vardells VMR EPOS System
2619/58 - Retailix Win POS and Storeline system
2619/59 - Gilbarco Passport Europe combined kiosk control and point of sale system
2619/60 – Wincor Nixdorf Site Control System
2619/62 – Sainsbury’s Retailix Forecourt Server and Storepoint Point of Sale system
2619/64 – Indigo SDL Retail POS
2619/66 – Meggitt Resilient Site Controller with Retailix Storepoint

9 RECOMMENDED TESTS

The following tests may be performed in addition to those specified in Regulations in order to determine conformity with the approved pattern.

- 9.1** Check that unit price changes are inhibited when a sale is in progress.
- 9.2** Check that the sequence of all `8's, blanks and all `0's appear on the dispenser display prior to the start of a sale.
- 9.3** Check that it is not possible to authorise more than one nozzle on one side at any time.
- 9.4** Check that when returning from calibration mode, the volume display to revert to two decimal places
- 9.5** Check that the correct checksum number is generated and can be displayed on the volume display.

- Figure 1 Global Century Dispenser
Figure 2 Wayne Global hydraulics
Figure 3 Wayne Global Hydraulics, meter sealing
Figure 4 Sealing of Wayne Integrated Pulsar (WIP)
Figure 5 Displays and Legends
Figure 6 Computer board
Figure 7 Display board
Figure 8 ISB board
Figure 9 Power supply unit
Figure 10 Power distribution board
Figure 11 Alternative Enclosure Style - Global Star 'H'
Figure 12 Alternative Enclosure Style - Global Star HH
Figure 13 Alternative Enclosure Style - Global Star LHR
Figure 14 Alternative Enclosure Style - Global Vista
Figure 15 Alternative Enclosure Style - EPT 390
Figure 16 Alternative Enclosure Style - EPT 390 (600)
Figure 17 Alternative Enclosure Style - Global Ovation
Figure 18 Global Ovation Unit Price Display
Figure 19 Global Ovation Sale/Volume Display
Figure 20 X-Flo Remote unit
Figure 21 X-Flo Suction unit
Figure 22 Wayne 'Burkert' assisted vapour recovery system with Vapour Gate Meter
Figure 23 TVC unit without LCD display
Figure 24 TVC unit with LCD display
Figure 25 TVC Density blocks
Figure 26 TVC Temperature sensor: LM335
Figure 27 TVC Typical installation of temperature sensor
Figure 28 TVC unit sealing arrangement
Figure 29 TVC Typical installation of temperature sensor and sealing arrangement
Figure 30 TVC Typical display of measurement data using 'Fuel Monitor' software
Figure 31 Wayne ATC – Global Star Installation
Figure 32 Wayne ATC – Global Century Installation
Figure 33 Wayne ATC – ISB mounted in electronic head
Figure 34 Wayne ATC – Probes mounted in dome cover
Figure 35 Wayne ATC – Sealing – TM module
Figure 36 Wayne ATC – Sealing – Temperature Probes
Figure 37 X-Flo sealing arrangements
Figure 38 Alternative X-Flo sealing arrangements
Figure 39 Helix Dispensers
Figure 40 Global Star H With Fuel Grade Selection Function
Figure 41 Alternative sealing electronic head
Figure 42 Alternative sealing electronics

10 CERTIFICATE HISTORY

ISSUE NO.	DATE	DESCRIPTION
2619/63	01 May 2012	Certificate first issued.
2619/63 Revision 1	14 January 2013	Revision 1 issued. Section 4.2.4 Helix™ fuel dispenser series added Section 7.2 Certificate 0402-MID-10 70 26 added
2619/63 Revision 2	25 February 2013	Revision 2 issued. Section 4.2.5 Global Star H With Fuel Grade Selection Function added
2619/63 Revision 3	15 September 2014	Revision 3 issued. Front page: Company name change Entire document all references to Dresser removed Section 4.4 added, Clarification of 5 litres minimum delivery Section 4.5 Alternative sealing methods added Section 7.1 Evaluation certificates added.



Figure 1 Global Century Dispenser

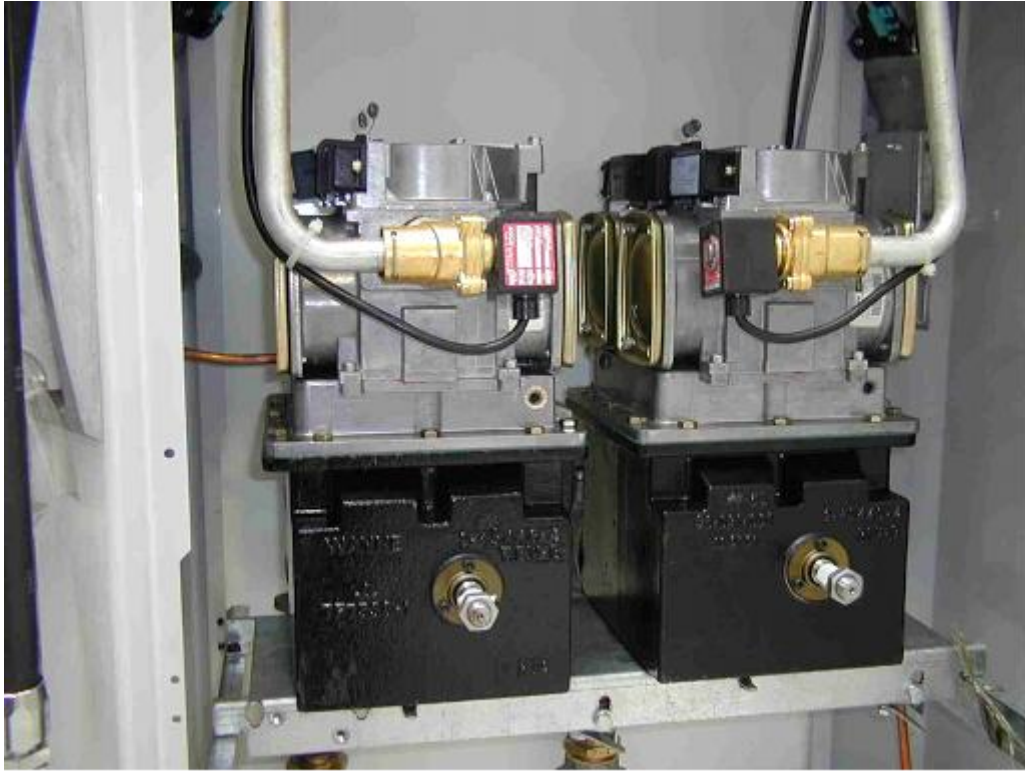

Figure 2 Wayne Global hydraulics



Figure 3 Wayne Global Hydraulics, meter sealing



Figure 4 Sealing of Wayne Integrated Pulser (WIP)



Figure 5 Displays and Legends

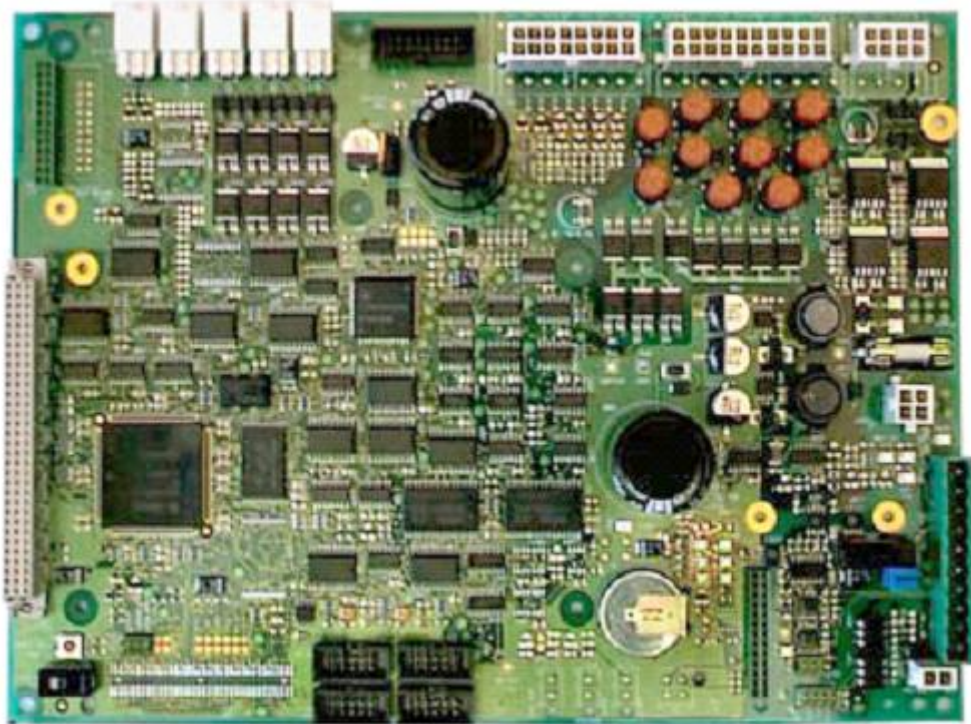

Figure 6 Computer board

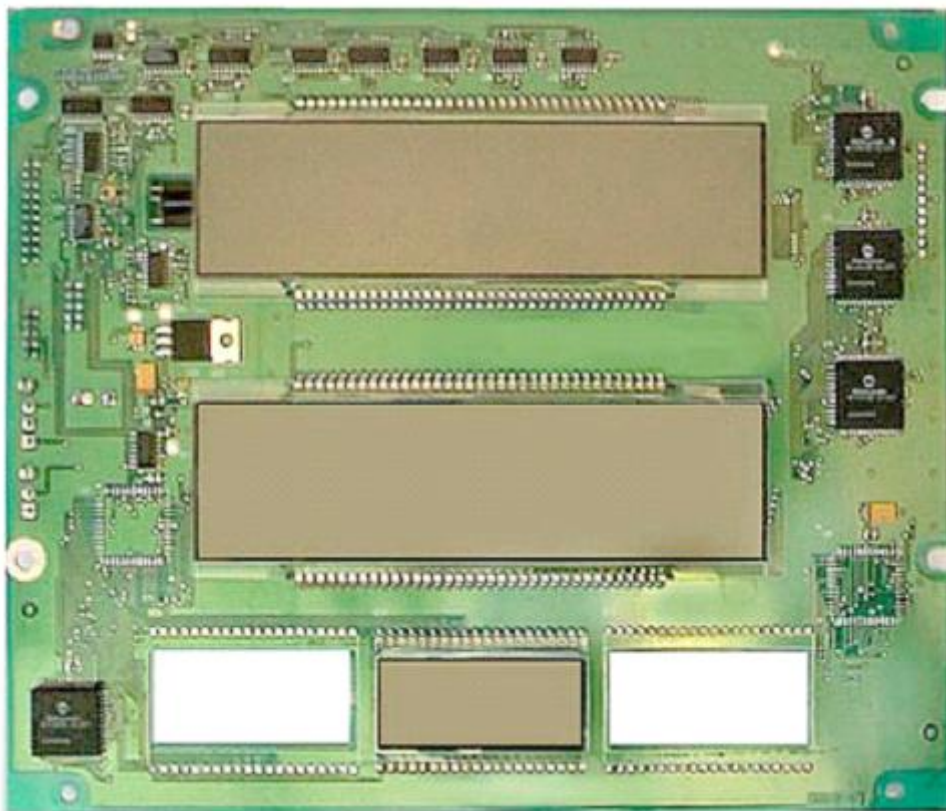

Figure 7 Display board



Figure 8 ISB board



Figure 9 Power supply unit

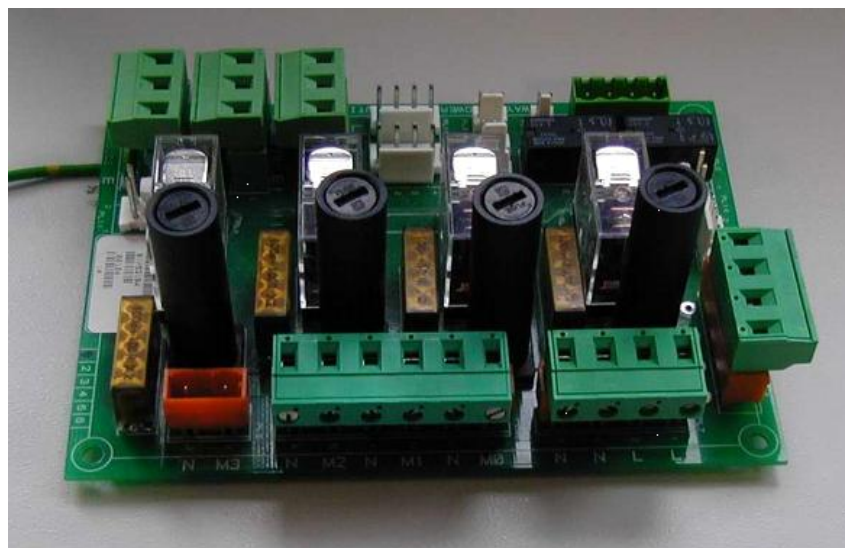

Figure 10 Power distribution board



Figure 11 Global Star 'H'



Figure 12 Global Star HH



Figure 13 Global Star LHR



Figure 14 . Global Vista

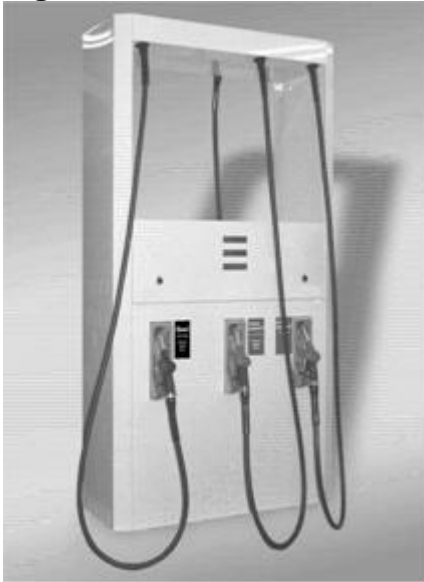

Figure 15 EPT 390



Figure 16 EPT 390 (600)



Figure 17 Global Ovation



Figure 18 Global Ovation Unit Price Display



Figure 19 Global Ovation Sale/Volume Display

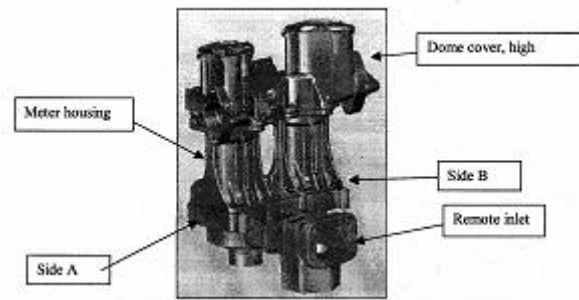

Figure 20 X-Flo Remote Unit

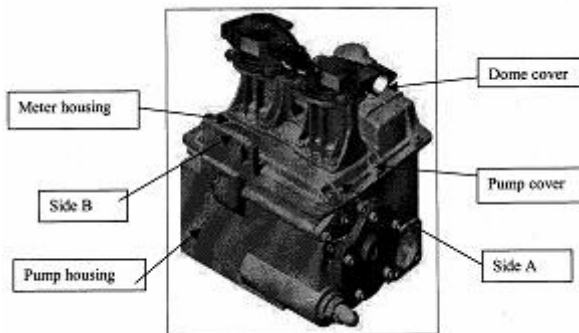

Figure 21 X-Flo Suction Unit

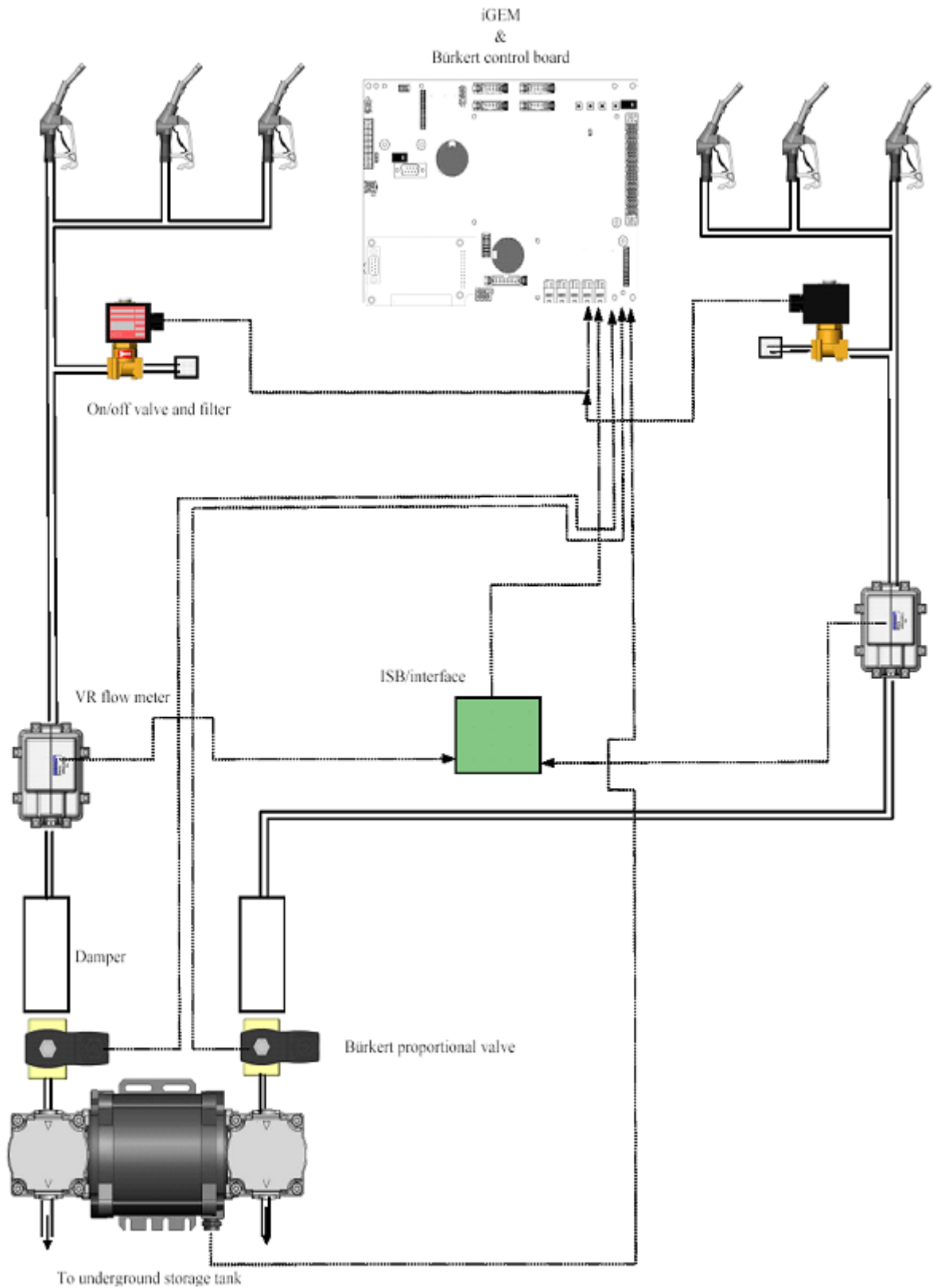
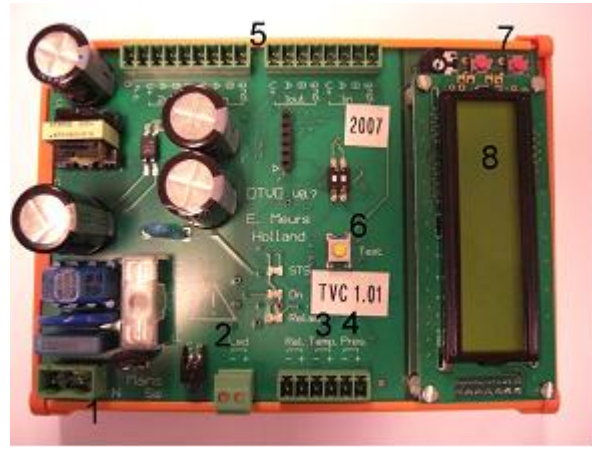

Figure 22..... Wayne 'Burkert' assisted vapour recovery system with Vapour Gate Meter



- 1 Power Supply connection 230V
- 2 Infrared Port for Data communication
- 3 Temperature sensor connection
- 4 Density block connection
- 5 Pulser channel connection
- 6 Calibration button TVC system on/off

Figure 23 TVC unit without LCD display



- 1 Power Supply connection 230V
- 2 Infrared Port for Data communication
- 3 Temperature sensor connection
- 4 Density block connection
- 5 Pulser channel connection and Calculator connection
- 6 Calibration button TVC system on/off
- 7 Scroll function for display information
- 8 Display

Figure 24 TVC unit with LCD display

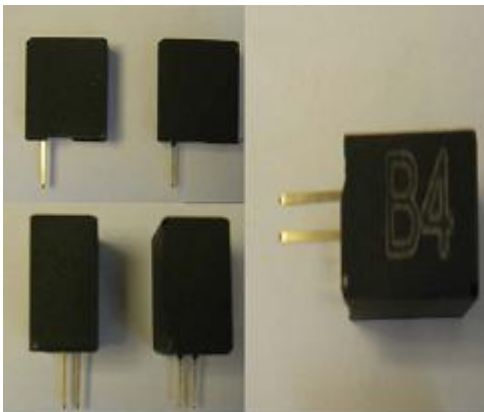

Figure 25 Density blocks



Figure 26 Temperature sensor: LM335



Figure 27 Typical installation of temperature sensor



Figure 28 TVC unit sealing arrangement



Figure 29 Typical installation of temperature sensor and sealing arrangement

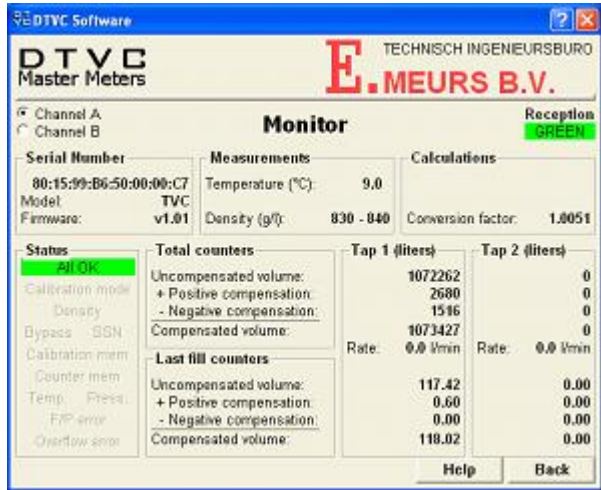

Figure 30 Typical display of measurement data using 'Fuel Monitor' software

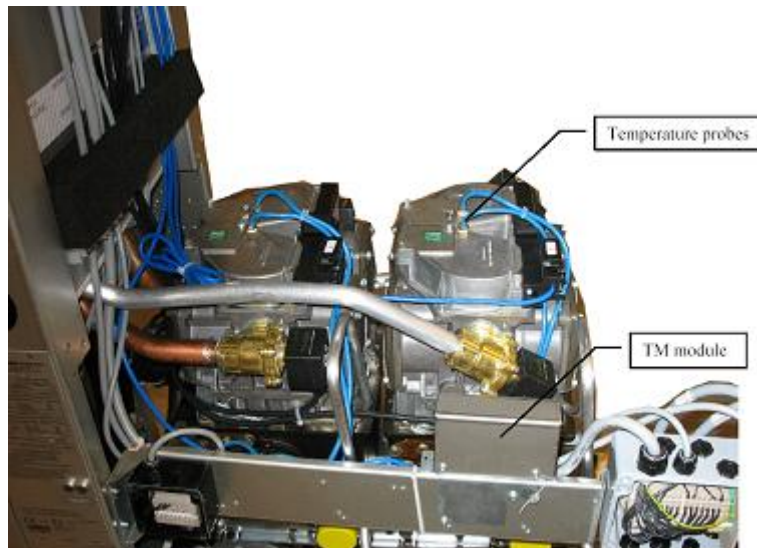

Figure 31 Wayne ATC – Global Star Installation

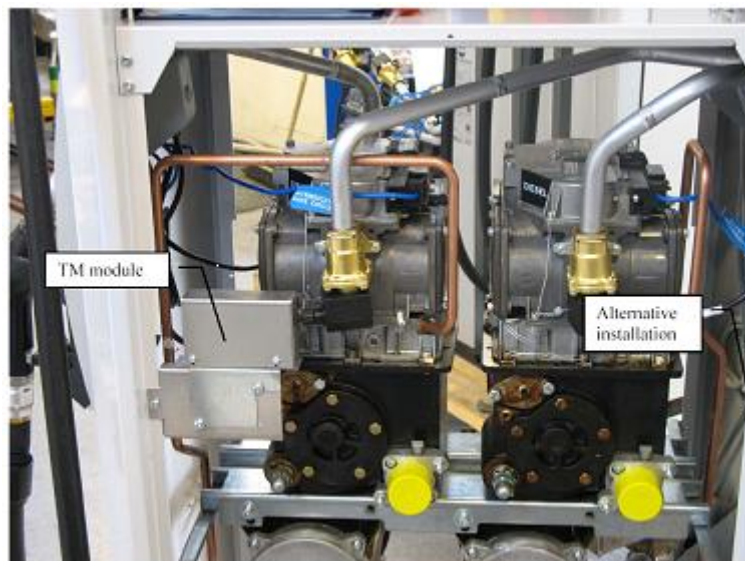

Figure 32 Wayne ATC – Global Century Installation



Figure 33 ISB mounted in electronic head



Figure 34 Probes mounted in dome cover



Figure 35.....Sealing – TM module



Figure 36.....Sealing – Temperature probes



Figure 37 X-Flo sealing arrangements

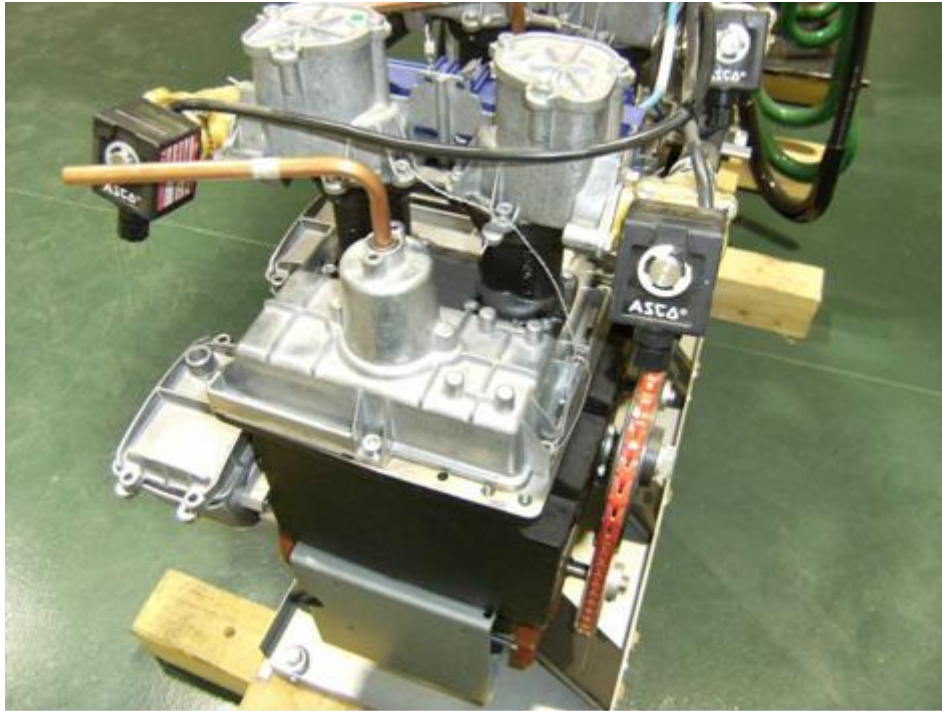

Figure 38 Alternative X-Flo sealing arrangements



Figure 39 Helix Dispensers



Figure 40 Global Star H With Fuel Grade Selection Function

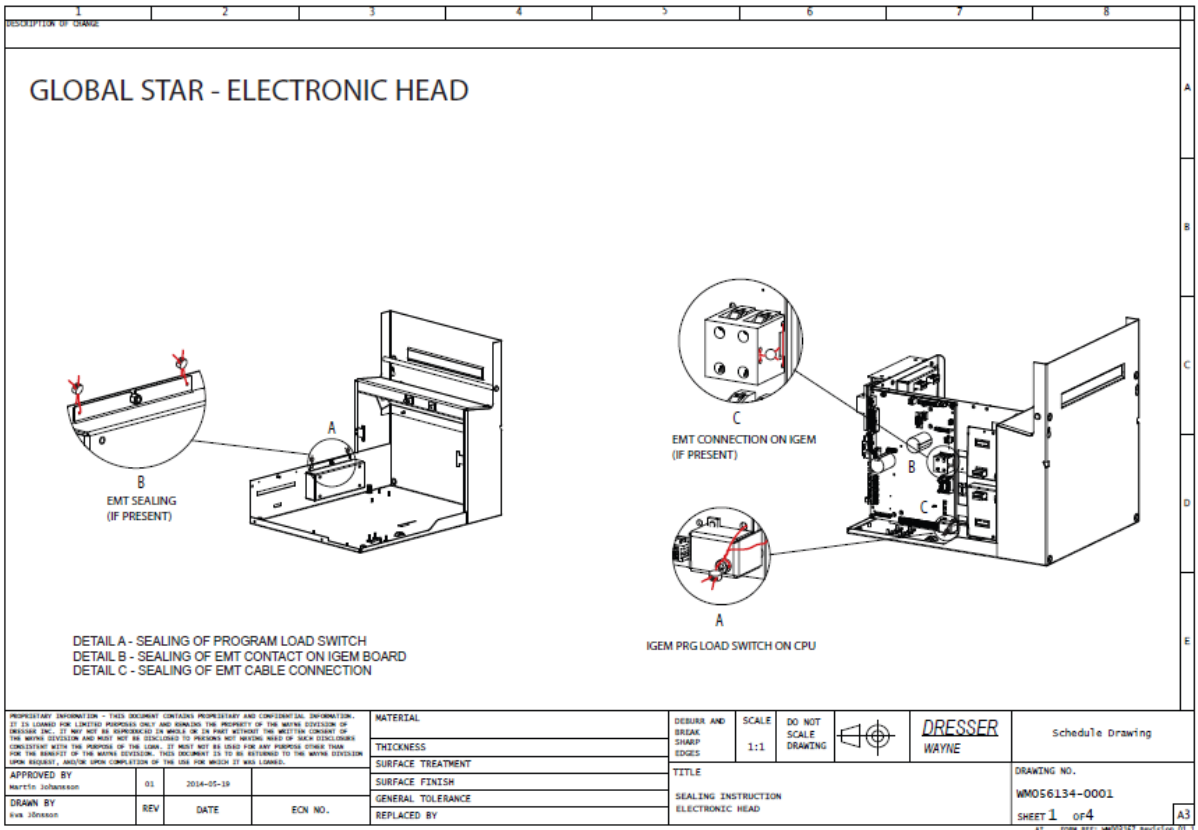

Figure 41 Alternative sealing electronic head

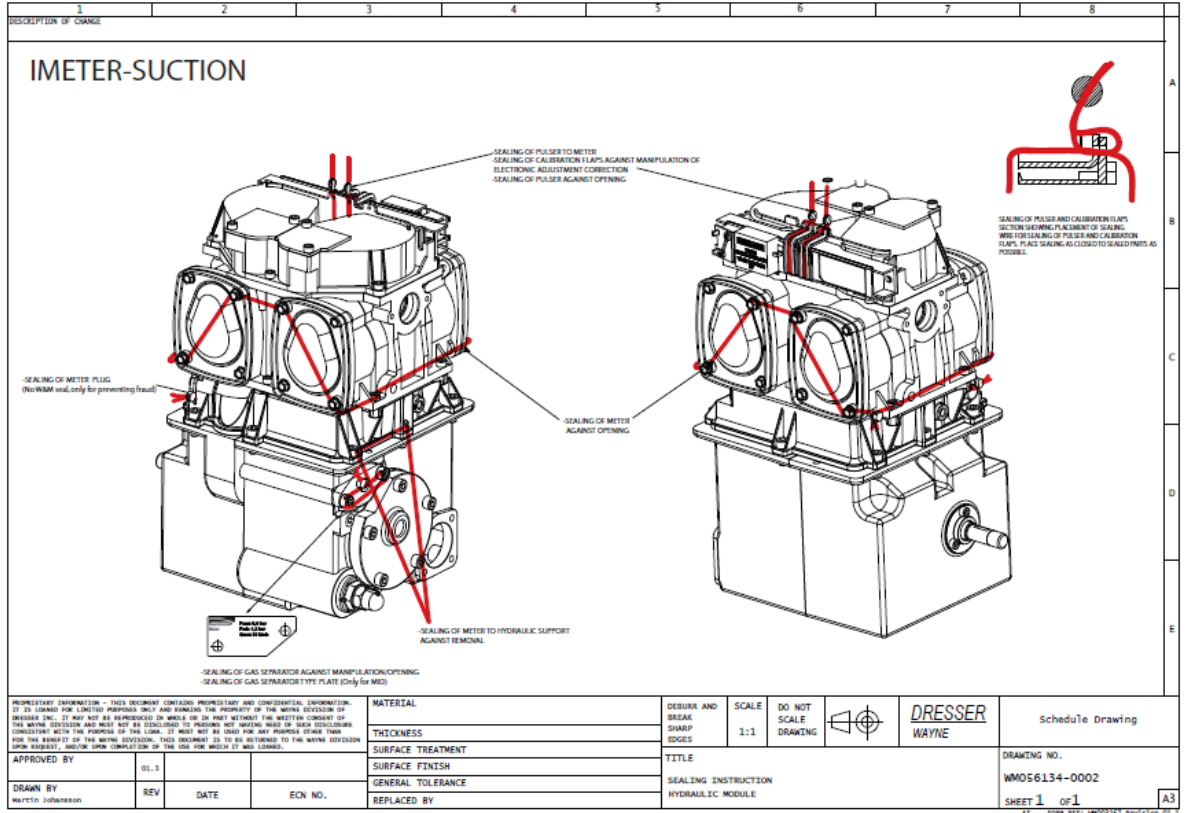

Figure 42 Alternative sealing electronics

© Crown copyright 2014.
 This material may be freely reproduced except for sale.