

MEDWAY NAVIGATION BRIDGE PROFILES

Cautionary Note: This document is a GUIDE ONLY to show the profile of bridge soffits (the undersides of the bridge) on the navigable River Medway. All users of this document should note that water levels WILL vary at any time of year and therefore there may be LESS headroom available under any of the bridges. Anyone navigating the Medway should satisfy themselves of the room available at each bridge before attempting to navigate through.

Thirty profiles are shown below for bridges between Allington Lock and Tonbridge Rail Bridge, upstream of Tonbridge town centre.

Whatman North Bridge



Upstream face

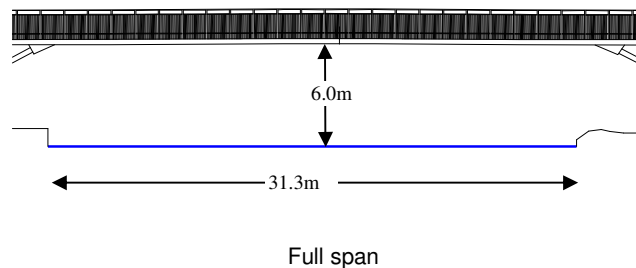

Full span

Whatman South Bridge



Upstream face

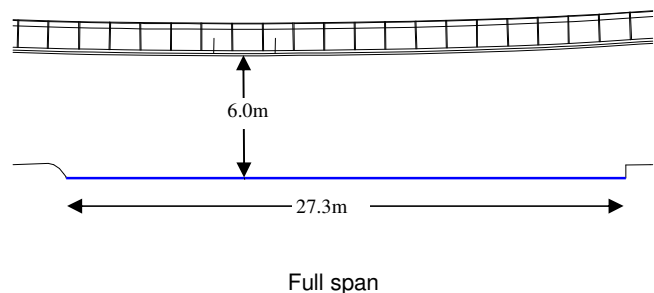

Full span

Maidstone Rail Bridge



Upstream face

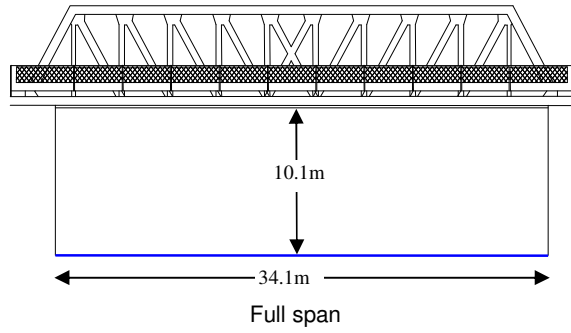

Maidstone New Bridge



Upstream face

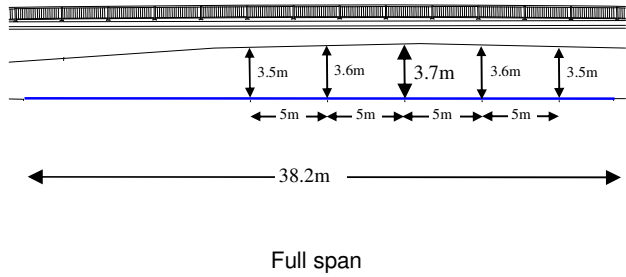

Maidstone Bridge



Upstream face

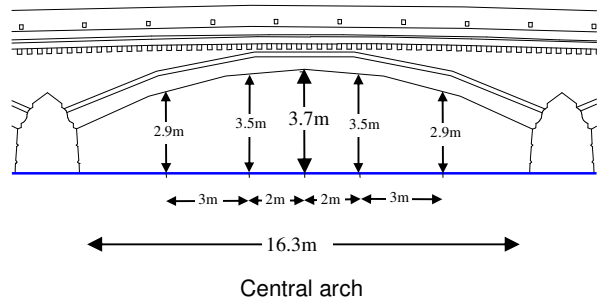

Lockmeadow Millennium Bridge



Upstream face

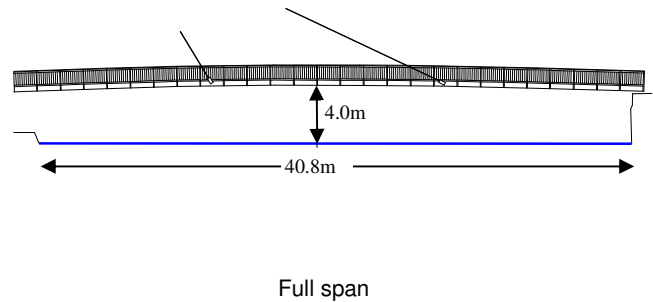

Tovil Footbridge



Upstream face

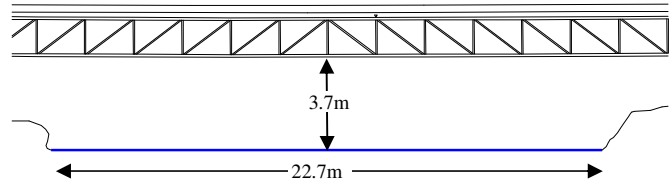

Full span

East Farleigh Bridge



Upstream face

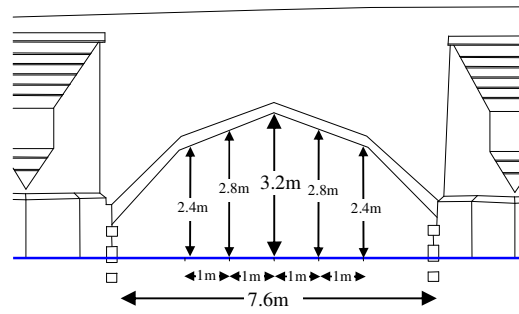

Second arch from right bank

Barming Footbridge



Downstream face

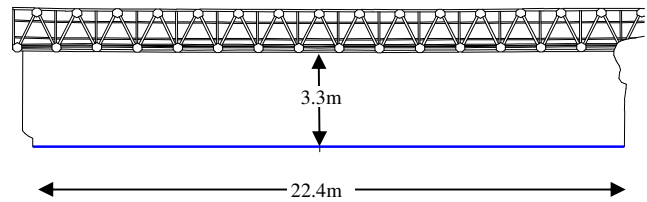

Full span

Teston Bridge



Upstream face

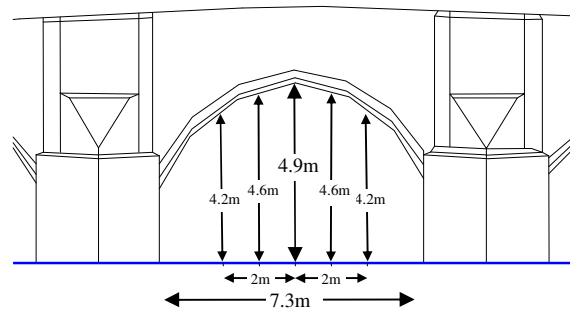

Second arch from right bank

Bow Bridge



Upstream face

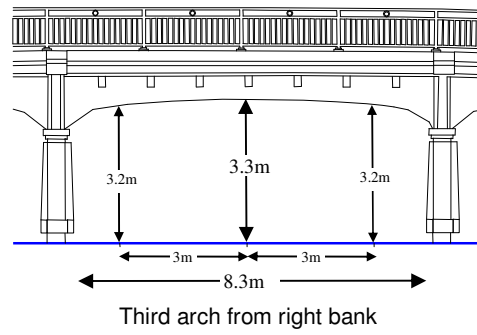

Hampstead Bridge



Upstream face

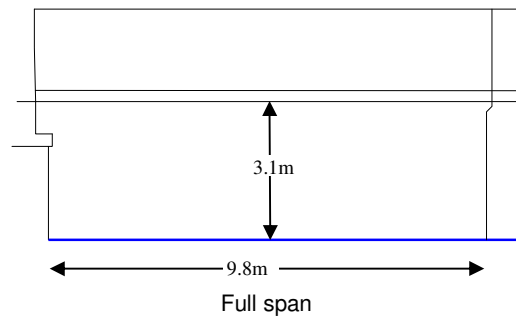

Lifting Bridge

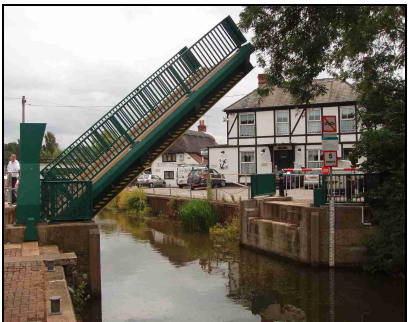

Downstream face

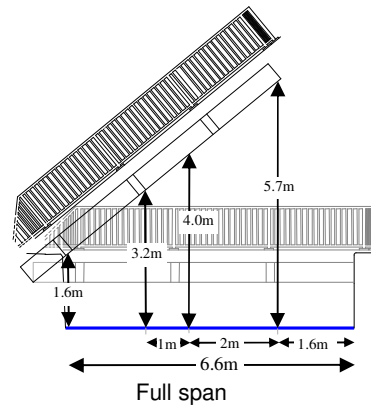

Anchor Footbridge



Downstream face

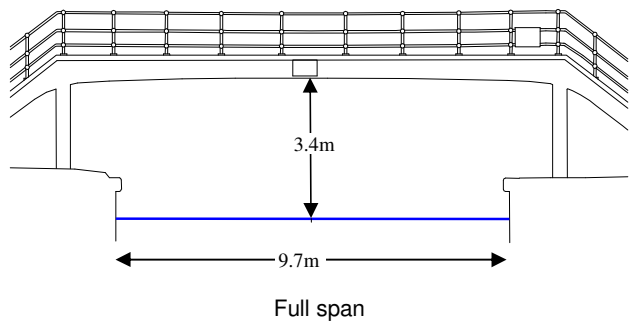

Stoneham Lock Footbridge



Upstream face

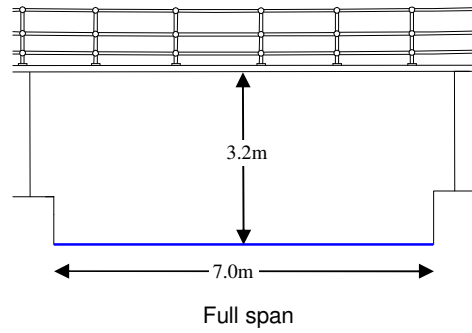

East Peckham Rail Bridge



Downstream face

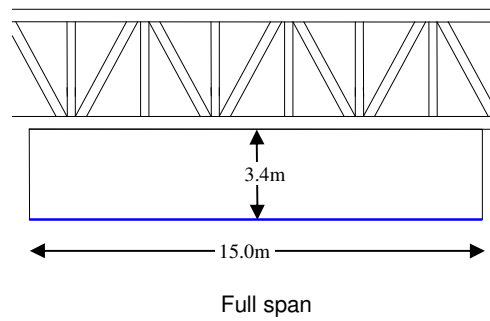

East Peckham Bypass



Downstream face

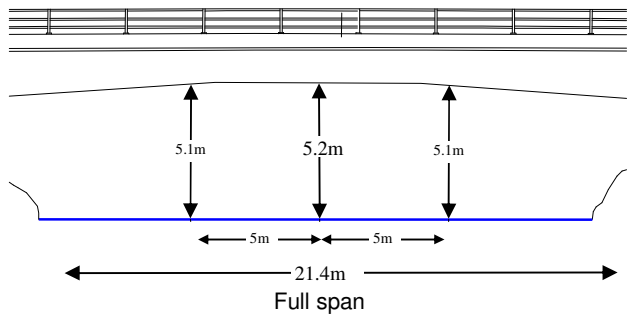

Branbridges



Upstream face

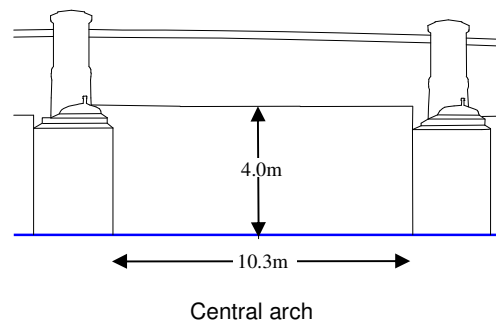

Wagon Bridge



Upstream face

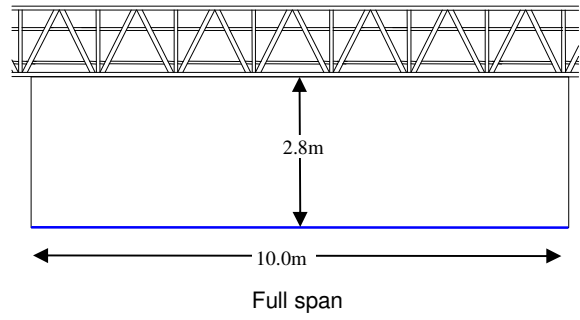

Stilstead Bridge



Downstream face

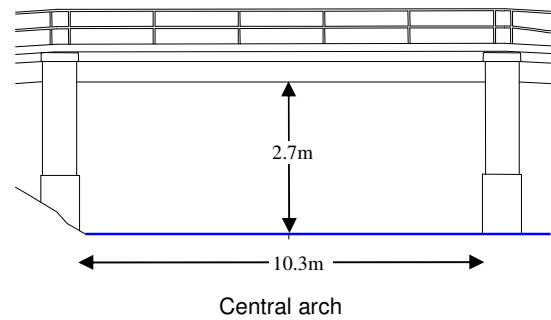

Ford Green Bridge



Upstream face

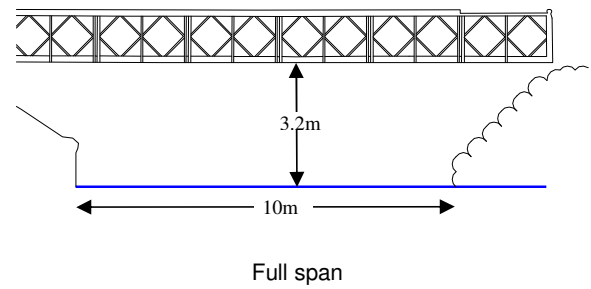

East Lock Footbridge



Upstream face

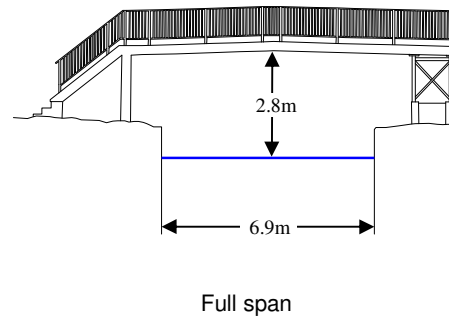

Hartlake Bridge



Upstream face

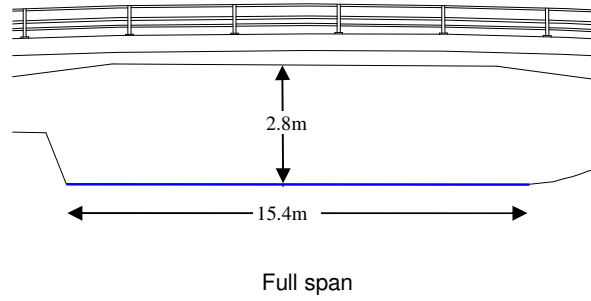

Full span

Gravel Pit Bridge



Downstream face

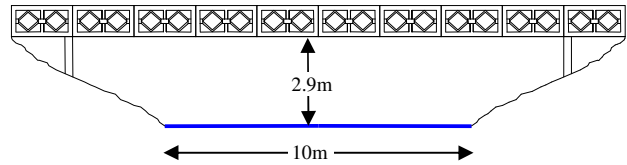

Full span

Cannon Bridge



Upstream face

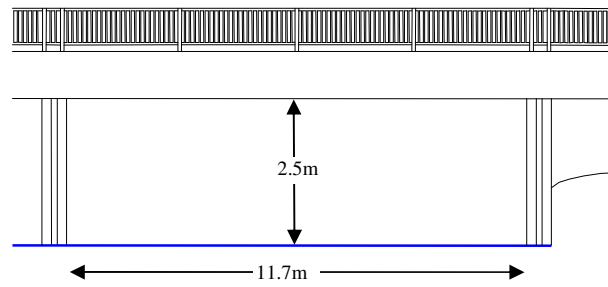

Full span

Great Bridge



Upstream face

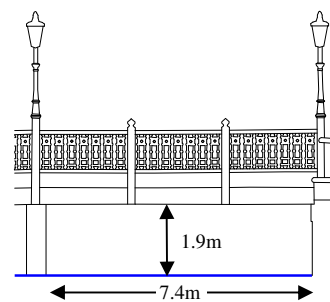

First arch from right bank

New Wharf Road Bridge



Upstream face

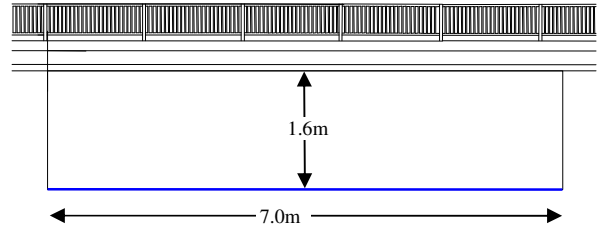

Full span

Remembrance Gardens Footbridge



Upstream face

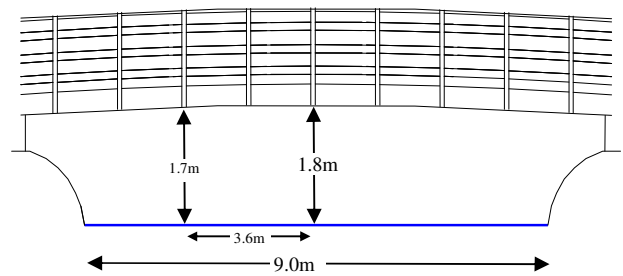

Full Span

River Walk Bridge

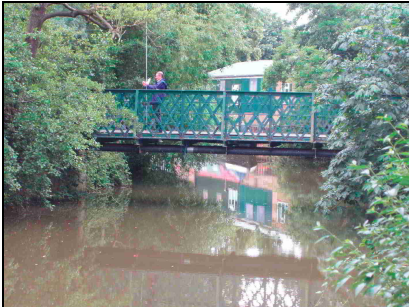

Upstream face

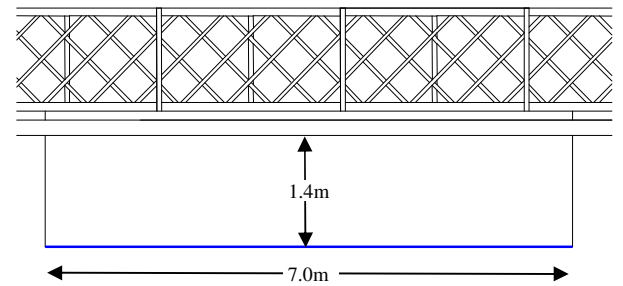

Full Span

Tonbridge Rail Bridge



Downstream face

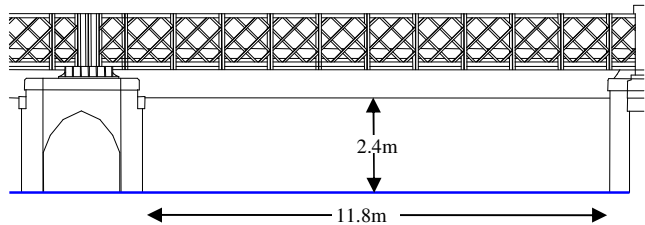

First arch from right bank