

Generic design assessment

AP1000 nuclear power plant design by Westinghouse Electric Company LLC

Consultation document



We are the Environment Agency. It's our job to look after your environment and make it **a better place** - for you, and for future generations.

Your environment is the air you breathe, the water you drink and the ground you walk on. Working with business, Government and society as a whole, we are making your environment cleaner and healthier.

The Environment Agency. Out there, making your environment a better place.

Published by:

Environment Agency
Rio House
Waterside Drive, Aztec West
Almondsbury, Bristol BS32 4UD
Tel: 0870 8506506

Email: enquiries@environment-agency.gov.uk

www.environment-agency.gov.uk

© Environment Agency

All rights reserved. This document may be reproduced with prior permission of the Environment Agency.

GEHO0510BRUW-E-P

Foreword

I'm pleased to introduce this Environment Agency consultation document inviting your comments on Westinghouse's AP1000 reactor design and the views that we have formed of it so far during our Generic Design Assessment (GDA) programme. Your comments will help inform our decisions about whether we should issue a Statement of Design Acceptability and, if so, what its caveats should be for this design. We have also published the equivalent document and begun consulting on the UK EPR design, the other reactor design in the GDA programme which was submitted by EDF and AREVA.

We and the Health and Safety Executive are independent regulators conducting robust assessments. When we jointly developed the GDA process and started our respective assessments about three years ago, our key objectives were:

- to have early influence on potential reactor designs that might be built in the UK so that we could be confident that they would meet the high standards that we require of safety, security, environment protection and waste management;
- to provide potential developers and investors in any new nuclear stations with our views about the designs, so reducing the associated regulatory risks;
- by assessing and influencing designs early, to help to ensure that any developments can achieve their project timescales and costs because they would be more fully specified before significant construction;
- to establish, subject to normal national and commercial security constraints, an open and transparent process of assessment; and,
- to build a professional and synergistic working relationship between the nuclear regulators as we worked jointly to develop, implement and carry out our GDA process.

So far, the GDA programme has been successful and we are making very good and timely progress towards these objectives. In March 2008 we and HSE jointly published our preliminary assessment of the reactor designs. We also established our joint public involvement process so that questions about the designs could be posed to and answered by the reactor designers. We see both questions and answers and can use these to help inform our assessments. In November 2009 HSE published its "step 3" reports on AP1000 and UK EPR designs. We also publish joint quarterly reports on our assessment progress indicating any concerns we have.

Publishing this document and consulting on the Environment Agency findings so far continues this good progress. In our assessments, we have identified some areas where more work is required by the reactor designers to provide further information and resolve technical issues. We are confident that these areas are resolvable and that they can be addressed by the reactor designer during GDA, or by a developer as part of its site specific applications.

On behalf of the Environment Agency we very much welcome your comments on both reactors and we look forward to hearing from you.

David Jordan

Director of Operations, Environment Agency, June 2010

Contents

Executive summary	7
1 About this consultation	11
1.1 About this document	11
1.2 Invitation to comment	11
1.3 How to respond	11
1.4 Data Protection Notice	12
1.5 Freedom of Information Act	12
1.6 Consultation events	13
1.7 What happens next?	13
1.8 Consultation Code of Practice	13
2 Consultation questions	14
3 Introduction	15
3.1 The Environment Agency	15
3.2 Our role in nuclear regulation	15
3.3 Our regulatory role in the development of new nuclear power stations	15
3.4 Our input to the Government's facilitative actions on nuclear new build	16
3.5 About Generic Design Assessment (GDA)	16
3.6 End of GDA detailed assessment steps	20
3.7 Regulatory basis for GDA	22
4 The AP1000 design	24
4.1 Outline of design	24
4.2 Sources, processing and disposal of radioactive waste	25
4.3 Non-radioactive waste	26
5 Guide to our detailed assessment	27
6 Management systems	30
6.1 Westinghouse's management system	30
6.2 Expectations for the operator's management system	33
7 Integrated waste strategy	35
7.1 Westinghouse's integrated waste strategy	35
7.2 Spent fuel strategy specifics	37
7.3 Decommissioning specifics	39
8 Best available techniques (BAT) to minimise production of radioactive waste	40
8.1 Sources of radioactivity	41
8.2 Processing of radioactive materials in the AP1000	49
8.3 Containment of radioactive liquids in the AP1000	55
9 Gaseous radioactive waste disposal and limits	57
9.1 Tritium	60

9.2	Carbon-14.....	61
9.3	Noble gases.....	63
9.4	Iodine radionuclides.....	64
9.5	Other radionuclides	66
9.6	Gaseous radioactive waste disposal to the environment.....	68
10	Aqueous radioactive waste disposal and limits	69
10.1	Evaporation in place of ion exchange.....	72
10.2	Boron discharge or boron recycle.....	73
10.3	Filtration options	73
10.4	Tritium.....	74
10.5	Carbon-14.....	76
10.6	Iodine radionuclides.....	77
10.7	Other radionuclides.....	78
10.8	Aqueous radioactive waste disposal to the environment.....	83
11	Solid radioactive waste.....	85
11.1	Creation of solid waste	85
11.2	Management and disposal of low level waste.....	86
11.3	Management and disposal of intermediate level waste	92
12	Spent fuel	96
12.1	Creation of spent fuel.....	96
12.2	BAT for fuel design	98
12.3	Management and disposal of spent fuel	98
12.4	BAT to minimise disposals of spent fuel	102
12.5	Summary of our assessment of spent fuel.....	102
13	Monitoring of radioactive disposals	104
13.1	Monitoring of gaseous disposals	104
13.2	Monitoring of liquid disposals.....	105
13.3	Monitoring of solid waste disposals	106
14	Impact of radioactive discharges.....	107
14.1	Verification of assessments of impact.....	108
14.2	Generic site concept.....	108
14.3	Our requirements for the assessment of doses to people	110
14.4	Source dose constraint	113
14.5	Site dose constraint	113
14.6	Dose limit	114
14.7	Doses to people – collective dose	114
14.8	Doses to other species	115
15	Other environmental regulations	120
15.1	Water abstraction.....	120

15.2	Discharges to water of non-radioactive substances	122
15.3	Pollution prevention for non-radioactive substances	127
15.4	Environmental Permitting Regulations 2010 (EPR 10) Installations	128
15.5	Management of non-radioactive waste	129
15.6	Control of Major Accident Hazards Regulations (COMAH)	131
15.7	EU Emissions Trading Scheme	133
16	Conclusion.....	134
	References	135
	Glossary	139
	Abbreviations.....	142
	Annex 1 – Draft interim statement of design acceptability	144
	Annex 2 – Compilation of other issues.....	148
	Annex 3 – AP1000 – ranges of discharges from operating PWRs.....	149
	Annex 4 – Sources and types of radioactivity in pressurised water reactors	170
	Annex 5 – Documents forming Westinghouse’s submission for GDA.....	178
	Annex 6 – Criteria for consultation	180
	Annex 7 – Places where consultation documents are advertised or can be viewed and list of consultees	181
	Annex 8 – Response form.....	183

Executive summary

Introduction to GDA

- 1 As the leading organisation working to protect the environment, it is the Environment Agency's role to regulate discharges and waste disposals from nuclear power stations in England and Wales and to ensure their impact on air, water and land is minimised.
- 2 In response to growing interest in nuclear power and potential applications to build new nuclear power stations in England and Wales, we have been working on a new approach, Generic Design Assessment (GDA), for assessing the environmental impacts of new reactor designs. GDA means that we assess the acceptability of the generic environmental aspects and the nuclear reactor design before individual site applications are made. This approach allows us to get involved at the earliest stage where we can have most influence and where lessons can be learned for site specific applications. It also gives us additional time to address regulatory and technical issues with designers and potential operators.
- 3 The new GDA approach has given us the opportunity to work more closely with the Health and Safety Executive (HSE), providing effectively a 'one-stop-shop' for nuclear regulation. The process is allowing a rigorous and structured examination of detailed environmental, safety and security aspects of the reactor designs, over approximately four years. We believe that GDA is improving efficiency both for the Regulators and the nuclear industry, and delivering greater protection for both people and the environment. GDA cannot provide a complete assessment of a final "site-specific" design as there will be other issues, operator specific or site related, that we would expect to be considered during the environmental permitting and site licensing stages.
- 4 We are conducting our GDA work in an open and clear way and will communicate with industry, academics, trade unions, non-Governmental Organisations and other interested groups and individuals throughout the process.
- 5 GDA is in two stages: the preliminary assessment and detailed assessment. We completed the preliminary assessment and published our findings in March 2008.
- 6 Westinghouse Electric Company LLC ('Westinghouse') submitted its AP1000 nuclear power plant design for generic design assessment in August 2007. Westinghouse published its submission on its website (www.ukap1000application.com) and invited people to comment. The submission has been revised during GDA, the current version on the website is up to date and is the basis of our detailed assessment.
- 7 Based on our past experience, authorising the disposal and discharge of radioactive waste is the area of regulation that has the highest profile, the greatest perceived uncertainties and the longest lead time for our permitting of new nuclear power stations. For those reasons, our GDA focuses mainly on radioactive waste issues, although we have also looked at aspects of the design that relate to other areas such as abstraction and discharges to water, pollution control issues, as well as management of non-radioactive waste.
- 8 This consultation document summarises our detailed assessment findings so far on environmental aspects of the AP1000TM nuclear power plant design. Our output from the GDA will be a public statement of our conclusions. If we are content with the environmental aspects of the design, that it should meet the high standards we expect, we will issue an Environment Agency statement of design acceptability (SODA). If we are not content, we will not issue a SODA. We will use the comments and issues raised in this consultation to help inform our decisions.
- 9 When we issued our guidance on GDA in 2007, we envisaged that when we came to a decision on the acceptability of a reactor design, we may need to attach caveats. Previous experience in similar projects has also shown that it is not unusual for industry to take significant time to completely resolve some of the technical issues raised by regulators, in view of the need for new analysis, tests or research, etc., to be carried out or for the design details to be completed. Also, there will be some

requirements for commissioning tests, maintenance schedule, and operating rules, etc., that can only be fully addressed by a future operator. In these instances, a 'satisfactory' response to a technical issue for the GDA could be one where the matter is not fully resolved or confirmed, but regulators judge it is acceptable for it to be carried forward for future resolution. If any of the issues are considered by regulators to be particularly significant, but still resolvable, then these would be identified as GDA Issues. In these cases the Statement of Design Acceptability would be labelled as 'Interim', and we will expect the Requesting Parties to produce a Resolution Plan that identifies how the Issue would be addressed and closed out. At this stage of consultation, Resolution Plans have not been prepared.

10 We have also identified in our consultation document any other issues and assessment findings that we would expect to be addressed during site permitting and licensing, reactor procurement, design development, construction, or commissioning.

11 When all GDA Issues have been addressed to our satisfaction then the interim status of the GDA outcomes would be reviewed and, if appropriate, a final Statement of Design Acceptability would be provided, together with a report describing the basis of the GDA Issue resolution. Only when all GDA Issues related to the SODA have been addressed to our satisfaction will we confirm to HSE that we are content it considers providing Consent to start nuclear safety related construction of the reactor.

12 Should a SODA be issued, the design and safety case will continue to evolve as the detailed design progresses and site-specific applications are developed. We would expect that the generic reactor design submitted for GDA and the SODA will be used to underpin the permissions to construct a fleet of reactors identical except for site-specific requirements and the requirements of different operators.

Our findings so far, pending consultation

13 We have now carried out a detailed assessment of Westinghouse's submission for the AP1000 nuclear power plant design and our conclusion, pending consultation, is that we could issue an interim statement of design acceptability for the AP1000. This would be subject to a number of potential GDA Issues covering the following areas:

Potential GDA Issues

- a) Decommissioning of the AP1000
- b) The radiologically controlled area ventilation system (VAS), and any other ventilation systems where there is potential for the release of radioactive waste to the atmosphere which do not have passive high efficiency particulate arrest (HEPA) filtration as part of the design.
- c) Disposability of spent fuel following longer term interim storage pending disposal.

14 From our assessment so far, we have also identified other issues covering the following areas:

Other issues

- a) The capability to include boron recycle in the AP1000 design shall be kept under review and a best available techniques (BAT) assessment provided at site specific permitting to demonstrate whether boron recycling represents BAT.
- b) Detailed arrangements for the hand over between Westinghouse and future operators shall be provided at site specific permitting, in particular with respect to matters that relate to the use of BAT to minimise radioactive discharges.
- c) The suitability and availability of appropriate mobile equipment for waste which is not compatible with the aqueous radioactive waste system shall be demonstrated at site specific permitting.

- d) Information relating to the provision of secondary containment for the monitor tanks shall be provided at site specific permitting.
 - e) A detailed and robust justification of options for carbon-14 abatement in radioactive waste discharges shall be provided at site specific permitting.
 - f) Providing evidence at site permitting that specific arrangements for minimising the disposals of low level waste and intermediate level radioactive waste for each site represent BAT.
 - g) Disposability of intermediate level radioactive waste (ILW) following longer-term interim storage pending disposal.
 - h) The monitoring of gaseous, aqueous and solid discharges and disposals of radioactive waste.
 - i) Waste from construction activities shall be included in the waste strategy for each site at site specific permitting.
- 15 We have provided a draft interim statement of design acceptability in Annex 1 to help inform this consultation. We also seek views on our proposed limits for radioactive waste discharges.
- 16 We have also raised concerns with Westinghouse regarding application of its Quality Management System (QMS) to the UK GDA project and, with HSE, expect to see further evidence of this before the end of GDA. Some of our GDA Issues and other issues are the subject of ongoing assessment by HSE in its GDA Step 4 assessment which may raise further matters that could affect our conclusions.

What next?

- 17 This consultation seeks your views on our preliminary conclusions following our detailed assessment so far of the Westinghouse AP1000 new nuclear plant design. We will carefully consider your views in reaching our decision on whether to issue a statement of design acceptability.
- 18 We want to hear from members of the public, industry, non-Governmental organisations (NGOs) or any other organisation or public body.
- 19 This 16 week consultation began on 28 June 2010 and will close on 18 October 2010. Please send your response to arrive by 18 October 2010.
- 20 There are a number of ways you can let us know your views.
- Online Visit our website at <https://consult.environment-agency.gov.uk/portal/ho/nuclear/gda>.
- 21 You can also submit a response by email, letter or fax. It would help us if you would send your comments using the form provided in Annex 8 of the main consultation document. Send them to:
- Email: gda@environment-agency.gov.uk
- Post: Sue Riley
Environment Agency
Ghyll Mount
Gillan Way
Penrith 40 Business Park
Penrith
Cumbria CA11 9BP
- Fax: 01768 865606
- 22 We will publish all responses to our consultation before the end of 2010 and summarise our progress with HSE in our quarterly reports, which we will continue to place on our joint website (www.hse.gov.uk/newreactors).

- 23 We will consider all the responses to our consultation and HSE's assessment before coming to a final decision on the acceptability of the AP1000. We will publish our final conclusions, having carefully considered all comments received, in our decision document that we intend to publish in June 2011.

1 About this consultation

24 The purpose of this consultation document is to:

- a) explain the pre-consultation findings of the Environment Agency's assessment of a new nuclear power plant design, the AP1000™, by Westinghouse Electric Company LLC (Westinghouse) (the 'requesting party').
- b) seek your views on the design and our assessment so far of the design.

25 The Health and Safety Executive (HSE) is also assessing the AP1000 from a safety and security viewpoint. Although we work closely with HSE, this consultation is only about the Environment Agency's assessment and not HSE's. If we receive any consultation responses that raise safety or security issues, we will pass them to HSE.

1.1 About this document

26 This document provides:

- a) An introduction to our role in nuclear regulation and the basis for GDA (chapter 3);
- b) An outline of the AP1000 design (chapter 4);
- c) A guide to our detailed assessment (chapter 5)
- d) Our GDA conclusions with our consultation questions, followed by our detailed assessment (chapters 6 to 15);
- e) Our overall conclusion (chapter 16)
- f) Annexes supporting the consultation document (Annexes 1 to 8).

27 A full list of consultation questions is found in chapter 2 as well as throughout the individual chapters.

1.2 Invitation to comment

28 This consultation seeks your views on our preliminary conclusions following our detailed assessment of the Westinghouse AP1000 new nuclear plant design. We will carefully consider your views in reaching our decision on whether to issue a statement of design acceptability

29 We want to hear from members of the public, industry, non-Governmental organisations (NGOs) or any other organisation or public body.

30 When responding please state whether you are responding as an individual or representing the views of an organisation.

31 This 16 week consultation began on 28 June 2010 and will close on 18 October 2010. Please send your response to arrive by 18 October 2010.

1.3 How to respond

32 There are a number of ways you can let us know your views.

Online

33 Visit our website at <https://consult.environment-agency.gov.uk/portal/ho/nuclear/gda>. The online consultation has been designed to make it easy to submit responses to the questions. We would like you to register so you can respond online. This will help us to gather and summarise responses quickly and accurately. To do this you must first [log in](#) or [register](#) if you have not yet done so already.

By email, letter or fax

- 34 You can also submit a response by email, letter or fax. It would help us if you would send your comments using the form provided in Annex 8. Send them to:

Email: gda@environment-agency.gov.uk

Post: Sue Riley
Environment Agency
Ghyll Mount
Gillan Way
Penrith 40 Business Park
Penrith
Cumbria
CA11 9BP

Fax: 01768 865606

Timescale

- 35 This 16-week consultation began on 28 June 2010 and will close on 18 October 2010. Please send your response to arrive by 18 October 2010.

1.4 Data Protection Notice

How we will use your information

We will use your information to help inform our decision on the generic design assessment of the AP1000.

We may refer to any comments/issues raised by you in our decision document and in other Environment Agency documents related to GDA for the AP1000, unless you have specifically requested that we keep your response confidential. We may also publish all responses after the consultation has closed. We will not publish names of individuals who respond. We will publish the name of the organisation for those responses made on behalf of organisations. Please indicate on your response if you want us to treat it as confidential (see 1.5 below).

We will place your information on our databases, to be accessed by our staff or our agents, as a record of information received. We may send your information to other relevant bodies, including government departments.

We may keep your name and address on our databases so that we can advise you of any further communications relating to GDA or applications for permits for new nuclear power stations, unless you specifically ask us not to do this.

1.5 Freedom of Information Act

Confidential responses

We may publish or disclose information you provide in your response to this consultation, including personal information, in accordance with the Freedom of Information Act 2000 (FOIA). If you want us to treat the information that you provide as confidential, please be aware that, under the FOIA, there is a statutory Code of Practice with which public authorities must comply and which deals, amongst other things, with obligations of confidence.

In view of this, it would be helpful if you could explain to us why you regard the information you have provided as confidential. If we receive a request to disclose the information, we will take full account of your explanation, but we cannot give an assurance that we can maintain confidentiality in all circumstances. An automatic confidentiality disclaimer generated by your IT system will not, in itself, be regarded as binding on the Environment Agency.

1.6 Consultation events

36 A stakeholder seminar is due to be held on 6 July 2010 to share our findings and preliminary views from our assessment and seek feedback. A programme of communications and stakeholder engagement is underway and will continue during the consultation period. We will do our best to respond positively to requests to attend meetings and other events.

1.7 What happens next?

37 We will acknowledge receipt of your response. We will consider carefully all the responses we get. If issues arise that fall outside our responsibilities, we will pass them to the appropriate Government department or public body.

38 Your comments, where relevant to the scope of our assessment (see below), will help us decide whether or not to issue a statement of design acceptability for the AP1000. We will publish a document that:

- a) sets out our decision;
- b) summarises the consultation responses and issues raised;
- c) sets out our views on those issues.

We expect to do this by June 2011.

1.8 Consultation Code of Practice

39 We are running this consultation in accordance with the criteria set out in the Government's Code of Practice on Consultation (see Annex 6).

40 If you have any queries or complaints about the way this consultation has been carried out, please contact:

Cath Beaver, Consultation Co-ordinator
Environment Agency, Rio House
Waterside Drive, Aztec West
Almondsbury, Bristol BS32 4UD
Email: cath.beaver@environment-agency.gov.uk

2 Consultation questions

41 Below is a list of questions that we are asking for responses to as part of this consultation on the AP1000¹ design:

42 Do you have any views or comments on our preliminary conclusions on:

1. management systems?
2. the radioactive waste and spent fuel strategy?
3. best available techniques to minimise the production of radioactive waste?
- 4a. best available techniques to minimise the gaseous discharge of radioactive waste?;
- 4b. our proposed annual disposal limits?;
- 4c. our proposed gaseous quarterly notification levels?
- 5a. best available techniques to minimise the aqueous discharge of radioactive waste?;
- 5b. our proposed annual disposal limits?;
- 5c. our proposed aqueous quarterly notification levels?
6. solid radioactive waste?
7. spent fuel?
8. monitoring of disposals of radioactive waste?
9. the impact of radioactive discharges?
10. the abstraction of water?
11. discharges of non-radioactive substances to water?
12. pollution prevention for non-radioactive substances?
13. Environmental Permitting Regulations 2010 (EPR 10) Schedule 1 activities?
14. non-radioactive waste?
15. Control of Major Accident Hazards (COMAH) substances?
16. the acceptability of the design?
17. Do you have any overall views or comments to make on our assessment, not covered by previous questions?

¹ AP1000™ is a trademark of Westinghouse Electric Company LLC.

3 Introduction

3.1 The Environment Agency

43 Our corporate strategy **Creating a better place 2010-2015** (Environment Agency, 2009b) sets out our aims and describes the role we will play in being part of the solution to the environmental challenges society faces.

44 Our strategy aims to create a better place by securing positive outcomes for people and wildlife, in five key areas. We will:

- a) act to reduce climate change and its consequences;
- b) protect and improve water, land and air;
- c) work with people and communities to create better places;
- d) work with businesses and other organisations to use resources wisely;
- e) be the best we can.

3.2 Our role in nuclear regulation

45 We regulate the environmental impacts of nuclear sites (such as nuclear power stations, nuclear fuel production plants, plants for reprocessing spent nuclear fuel) through a range of environmental permits. These permits may be needed for one or more of the site preparation, construction, operation and decommissioning phases of the plant's lifecycle.

46 The permits we issue can include conditions and limits. In setting these, we take into account all relevant national and international standards and legal requirements, to ensure that people and the environment will be properly protected. These standards and requirements are described in Government and Environment Agency guidance available at:

<http://www.defra.gov.uk/environment/policy/permits/index.htm>

<http://www.environment-agency.gov.uk/business/topics/permitting/32320.aspx>

http://www.decc.gov.uk/en/content/cms/what_we_do/uk_supply/energy_mix/nuclear/radioactivity/government/legislation/legislation.aspx

<http://www.environment-agency.gov.uk/business/sectors/32533.aspx>

47 We inspect sites to check that the operator is complying with the conditions and limits and that they have arrangements in place to help ensure compliance. We may take enforcement action (for example, issuing an enforcement notice or taking a prosecution) if they are not.

48 We regularly review permits, and vary them if necessary, to ensure that the conditions and limits are still effective and appropriate.

49 We work closely with the Health and Safety Executive (HSE) which regulates the safety and security aspects of nuclear sites.

3.3 Our regulatory role in the development of new nuclear power stations

50 As for existing nuclear sites, any new nuclear power station will require environmental permits from us to cover various aspects of site preparation, construction, operation and eventually decommissioning. In the light of Government and industry expectation that plants of almost the same design might be built on a number of sites and potentially be run by different operating companies, we have split our process for assessing and permitting the operational stage of new nuclear power stations into two phases.

- 51 In the first phase, generic design assessment (GDA), we carry out detailed assessments of candidate designs and, at the end, provide a statement about the acceptability of the design. We may attach caveats to the statement. We are in this phase now – this consultation document is about our assessment of the AP1000 design.
- 52 In the second phase, we would receive applications for environmental permits for specific sites. In determining these applications, we will take full account of the work we have done during GDA, so that our efforts will be focused on operator and site-specific matters including how the operator has addressed any caveats attached to the statement of acceptability.
- 53 For GDA, we have worked closely with HSE to assess areas where we have overlapping regulatory responsibility including radioactive waste and spent fuel management, and management arrangements for control of design changes, and control of GDA submission documents.

3.4 Our input to the Government’s facilitative actions on nuclear new build

- 54 We have provided specialist advice, where appropriate, and responded to consultations relating to the actions taken by Government to:
- a) reduce the regulatory and planning risks associated with investing in new nuclear power stations;
 - b) ensure that operators of new nuclear power stations set aside funds to cover the costs of decommissioning and long-term waste management and disposal.

55 These include:

- a) **Strategic siting assessment** – this aims to identify those sites that are strategically suitable for the deployment of new nuclear power stations by the end of 2025. The selected sites would be listed in the Nuclear National Policy Statement (NNPS) (DECC, 2009b). This would provide the framework for decisions on planning consent (Development Control Orders) by the new Infrastructure Planning Commission². At the time of writing the Government has consulted on a draft NNPS.
- b) **Justification** – before any new type of nuclear power station can be built in the UK, it must be 'justified', that is, it must be shown that the net benefits outweigh any health detriment. At the time of writing the Government has consulted on its proposed decision that the AP1000 and the UK EPR power stations are justified (DECC, 2009c).
- c) **Funded decommissioning programme** – *The Energy Act 2008* requires any operator of a new nuclear power station to have a funded decommissioning programme, approved by the Secretary of State, in place before construction begins and to comply with this programme. At the time of writing, the Government has consulted on draft funded decommissioning programme guidance (BERR, 2008b).

3.5 About Generic Design Assessment (GDA)

- 56 GDA means that we assess the acceptability of the environmental aspects of an overall design before individual site applications are made. GDA allows us to get

² In the Coalition Agreement following the May 2010 General Election, the Government stated it will “abolish the unelected Infrastructure Planning Commission and replace it with an efficient and democratically accountable system that provides a fast-track process for major infrastructure projects.” See http://www.cabinetoffice.gov.uk/media/409088/pfg_coalition.pdf

involved with designers and potential operators of new nuclear power stations at the earliest stage, where we can have most influence and where lessons can be learned before construction begins. This early involvement also means that designers and potential operators can better understand the regulatory requirements before they make significant investment decisions.

57 Our guidance (Environment Agency, 2007) sets out in detail the process that we follow during generic design assessment. It has six main elements:

- a) **Initiation** – we make an agreement with the requesting party under section 37 of Environment Act 1995 and receive a submission.
- b) **Preliminary assessment** – we make an outline examination of the submission to find out if:
 - i) we need further information;
 - ii) there are any issues that are obviously unacceptable;
 - iii) any significant design modifications are likely to be needed.
- c) **Detailed assessment** – we examine the submission in detail to decide initially if we might issue a statement of design acceptability.
- d) **Consultation** – we consult widely on our initial view. We produce a consultation document explaining our view and, if we consider that we might issue a statement of design acceptability, we may set out a draft template permit appropriate to the design.
- e) **Post consultation review** – we carefully consider all relevant responses to the consultation.
- f) **Decision and statement** – we decide whether we should issue a statement of design acceptability and, if so, what GDA Issues, if any, we should attach to it. We publish a document that provides the background to and basis for our findings.

58 The remainder of this chapter describes how we have applied this process, so far, to the AP1000 in GDA.

3.5.1 Initiation and preliminary assessment

59 Our process for the first stage of GDA for the AP1000 is described in our report on our preliminary assessment (Environment Agency, 2008a). In summary:

- a) We set up an agreement with Westinghouse Electric Company LLC to carry out GDA of the AP1000, which came into effect in July 2007.
- b) The Joint Programme Office (JPO) received Westinghouse's submission in August 2007.
- c) With HSE, we launched the 'public involvement process' in September 2007. This enabled the public to view and comment on this and three other submissions. (See: <http://www.hse.gov.uk/newreactors/publicinvolvement.htm>)
- d) We carried out our preliminary assessment and concluded that we needed further information.
- e) We raised a Regulatory Issue on Westinghouse in February 2008 setting out the further information that we needed.
- f) We published our report on our preliminary assessment in March 2008.
- g) Westinghouse completely revised its submission during 2008 and provided an environment report (ER) with supporting documents. It reviewed and updated the ER in March-April 2010.

3.5.2 Detailed assessment

60 We began our detailed assessment in June 2008.

3.5.2.1 The submission

61 We have carried out our assessment using the information Westinghouse provided in the documents listed in Annex 5 (the 'submission'). These contain the additional information provided in response to our Regulatory Issue and in response to 42 technical queries and nine Regulatory Observations that we raised during our detailed assessment.

3.5.2.2 Liaison with HSE (and other bodies)

62 We have worked closely with HSE throughout GDA. This enables us to achieve the right balance between environmental and safety issues in relation to radioactive waste. We have considered HSE's step 3 reports (available at <http://www.hse.gov.uk/newreactors/reports.htm>). Should any [further] relevant issues arise from their ongoing GDA (step 4), we expect that HSE will identify them in its response to this consultation.

63 We have also liaised with the Food Standards Agency and the Health Protection Agency on matters relating to the assessment of doses to members of the public. We have maintained contact with Natural England in light of its interest in the assessment of the impact on non human species and with the Nuclear Decommissioning Authority in light of its interest in the disposability of solid radioactive waste. We will also be consulting with these organisations as part of GDA.

3.5.2.3 Public involvement process

64 The opportunity for the public to access information about the AP1000, submit comments and receive responses from the requesting parties, has remained available throughout the detailed assessment stage.

65 We have encouraged the requesting parties to make it easier for people to access their design information. Westinghouse relaunched its website in Autumn 2009. The design information on its website has been updated at intervals and contains all the information provided to the regulators except that which is commercially confidential or subject to national security restrictions.

66 We have continued to raise awareness of GDA and the opportunity for the public to comment through:

- a) relaunch of the regulators' website (www.hse.gov.uk/newreactors) in March 2009, providing more information in a more user-friendly way;
- b) meeting with or holding events for key stakeholder groups (including non-governmental organisations, local authorities, local community liaison committees/site stakeholder groups for existing nuclear sites);
- c) attending stakeholder events organised by the Department of Energy and Climate Change (DECC) as part of its consultation on the draft Nuclear National Policy Statement;
- d) targeting nuclear and energy academics, and trade unions;
- e) providing media articles and adverts, and publicising our work at national and local events.

67 Where they relate to our areas of interest, our detailed assessment has taken account of comments received up to 1 April 2010, and Westinghouse's responses to those comments – see Chapters 6 - 15. We will address any comments on environmental issues we receive after this date alongside responses to this consultation.

68 Comments received about the public involvement process itself are addressed in a report published at the end of 'step 3' of HSE's assessment (HSE, 2009b). A similar

report will be published at the end of 'step 4'. The public involvement process remains available during the consultation period as HSE is still carrying out 'step 4' of its assessment.

69 Copies of our stakeholder engagement strategy for nuclear new build and our national and local stakeholder engagement plans for the generic design assessment are available on request or from our joint website www.hse.gov.uk/newreactors/publicinvolvement.htm. Feedback on both is welcome.

3.5.2.4 Assessment reports

70 We have documented our detailed assessment in a series of assessment reports, which are listed in Annex 1 (Schedule 3). These are summarised in Chapters 6 – 15 of this document.

3.5.2.5 Draft statement of design acceptability

71 To help the consultation process, we have also included in this document (Annex 1) a draft statement of design acceptability for the AP1000 based on our initial (that is, before consultation) view.

72 Enough information needs to be submitted so that the regulators can fully assess the design against our Radioactive Substances Regulation Environmental Principles, and HSE's safety assessment principles.

73 We acknowledge that some of the reactor designs that are taken through GDA may not be fully complete. This could mean that, after any GDA statement of design acceptability (SODA) or design acceptance confirmation (DAC) are issued, parts of the design may continue to be developed and technical issues could arise that need to be addressed.

74 If a SODA or DAC are to be issued, the regulators' preference is to close-out all generic issues during the GDA detailed assessment steps so they can issue these 'clean' and without caveats.

75 Any of the design and environment/safety case details that are not supplied by the Requesting Parties (RPs), have to be considered as 'out of scope' for GDA. However, if we believe that this information should have been supplied as part of GDA, as it forms part of the requirements specified in our guidance documents (Environment Agency 2007, HSE 2008, and OCNS 2007), then either we will not issue a SODA/DAC, or we may choose to identify this information as a GDA Issue to an interim SODA / DAC (GDA Issues are discussed below).

76 It is important to note that our assessment can only be on the documentation that is provided and is therefore 'within scope' for GDA. The scope of what is included within GDA will be defined by the set of documents that form the GDA design reference. It is expected that, at the very least, the design reference information will match that which has to be submitted for GDA as set out in our guidance documents (Environment Agency 2007, HSE 2008, and OCNS 2007).

3.5.3 Consultation

77 We are now in the consultation stage of our process, which runs from 28 June 2010 to 18 October 2010. We are consulting widely so that people can bring any issues to our attention. Before this consultation, we have not made any final decisions, and will not do so until we have carefully considered all the responses.

3.5.4 Post consultation review

78 We will acknowledge all responses (see "How to respond" in chapter 1.3), but we will not generally enter into further correspondence with those who respond.

79 We will carefully consider each response that we receive. If issues arise that fall outside our responsibilities, we will pass them to the appropriate regulator, Government department or public body.

80 Where we need advice from other organisations that have expertise on specific topics, we will seek the expert views of the Government department or official public body concerned, for example, the Radiation Protection Division of the Health Protection Agency – the Government's adviser on radiological protection. Similarly, if necessary, we will seek further information or clarification from the requesting party.

3.5.5 Decision and statement

81 In the light of all the information obtained, including that received during and after consultation, we will decide whether to issue a statement of design acceptability and what GDA Issues should be attached to it.

82 We will publish a document that:

- a) sets out the basis for our decision;
- b) summarises the consultation responses and issues raised;
- c) sets out our views on those issues and how they have informed our decision making. Where specific input is not taken on, we will identify why.

3.6 End of GDA detailed assessment steps

83 The output from the GDA detailed assessment steps will be a public statement from the regulators on their conclusions. For the Environment Agency, this will be a decision document following our consultation.

84 There could be three different outcomes:

- a) If we are fully content with the environmental aspects of the design safety case then we will provide the RP with an Environment Agency Statement of Design Acceptability (SODA). However, there may still be other issues arising from our assessment that need to be carried forward for future resolution in later safety case submissions.
- b) If we are largely content with the environmental aspects of the design then we will provide the RP with an Environment Agency Interim Statement of Design Acceptability and identify the outstanding GDA Issues. These outstanding GDA Issues need to be cleared before a final Statement of Design Acceptability can be provided.
- c) If we are not content with the environmental aspects of the design then no Statement of Design Acceptability will be provided to the RP. This would be the case where we judge that there is an unacceptable shortfall in the design or safety submissions (i.e. where the issues are very significant). However, the RP could still propose to undertake subsequent additional work to address the shortfalls and this might allow a Statement of Design Acceptability to be provided at some future date.

85 If our assessment of the design is generally positive but some environmental concerns remain, these will be identified when we issue the SODA. The concerns will be identified, and we are currently calling them GDA Issues to the SODA. The RPs can make sure that they minimise the number of Issues by supplying quality and detailed GDA submissions, along with timely and full responses to the issues we raise.

86 The Regulators have recently issued further guidance on the Management of GDA Outcomes (including GDA scope, our SODA, HSE's Design Acceptance Confirmation (DAC) and GDA Issues) and this is available on the joint regulators website: www.hse.gov.uk/newreactors (Joint Regulators, 2010).

3.6.1 Environment Agency statement of design acceptability

87 Our statement of design acceptability will state our view on the acceptability of the design to be permitted, under the relevant environmental legislation, for:

- a) the disposal of radioactive waste (gaseous, aqueous and solid);
- b) the discharge of non-radioactive substances to water;
- c) the operation of conventional plant (for example, combustion plant used as auxiliary boilers), where applicable;
- d) the disposal or recovery of non-radioactive waste, where applicable;
- e) the abstraction of water from inland waters or groundwater, where applicable.

88 Our view on the acceptability of the design with respect to the environmental requirements of the COMAH regulations will also be stated.

89 If we provide an Interim Statement of Design Acceptability, it will still mean that we are confident that the design is capable of being built and operated in the UK in a way that is environmentally acceptable, but that there are some GDA Issues that we want to see further progressed before HSE consideration be given to providing Consent³ to start nuclear safety related construction for the reactor.

90 The Statement of Design Acceptability will refer to the Final GDA Submission (environment submissions and the Design Reference) as the basis of what has been included within the scope of GDA.

3.6.1.1 GDA Issues

91 The ultimate output from the GDA assessment will be our Decision Document following consultation and, if appropriate, a Statement of Design Acceptability.

92 Previous experience in similar projects has shown that it is not unusual for industry to take significant time to completely resolve some of the technical issues raised by regulators, in view of the need for new analysis, tests or research etc to be carried out or for the design detail to be completed. Also, there will be some requirements for commissioning tests, maintenance schedule, and operating rules, etc., that can only be fully addressed by a future Operator. In these instances, a 'satisfactory' response to a technical issue for the GDA could be one where the matter is not fully resolved or confirmed, but regulators judge it is acceptable for it to be carried forward for future resolution.

93 It might then be appropriate for us to allow the project to proceed in a controlled manner. If any of the issues are considered by regulators to be particularly significant, but still resolvable, then these would be identified as GDA Issues. In these cases the Statement of Design Acceptability would be labelled as 'Interim', and we will expect the Requesting Parties to produce a Resolution Plan that identifies how the Issue would be addressed and closed out. At this stage of consultation, Resolution Plans have not been prepared.

94 We have also identified in our consultation document any other issues and assessment findings that we would expect to be addressed during site permitting and licensing, reactor procurement, design development, construction, or commissioning. Following review in the light of relevant consultation responses, these would also be identified in our Decision Document at the end of GDA, together with an indication of

³ A Consent is required before the nuclear site licensee can carry out certain activities identified in the licence or other activities which HSE has the power to specify. For example, a Consent from HSE is required before a reactor is allowed to be started up again following a periodic shutdown. In order to secure a Consent the licensee must satisfy HSE that the proposed action is safe and that all procedures necessary for control are in place. See <http://www.hse.gov.uk/nuclear/silicon.pdf>

the point before which they will need to be cleared during the reactor procurement, design development or construction programme.

95 Any issues identified will not come as a surprise to the RP. The subject areas in which they might arise will be discussed with the RP during our assessment and every opportunity given for them to be cleared at an early stage. For additional transparency, we will identify the most significant issues within our public quarterly joint progress reports.

96 When all GDA Issues have been addressed to our satisfaction then the Interim status of the GDA outcomes would be reviewed and, if appropriate, a final Statement of Design Acceptability would be provided, together with reports describing the basis of the GDA Issue resolution. As noted above, only when all GDA Issues have been addressed to the satisfaction of HSE and Environment Agency will consideration be given to providing Consent to start nuclear safety related construction of the reactor.

3.7 Regulatory basis for GDA

97 The statement of design acceptability is provided as advice to the RP, in accordance with section 37 of the Environment Act 1995, and has no other formal legal status. However, we will take full account of the work that we have done during GDA, if we receive applications for environmental permits relating to a design that has been through GDA.

98 The Environment Agency regulates several aspects of the operation of nuclear power stations in England and Wales. Previously, this was done under a number of regulatory regimes, but many of these have now been drawn together into a single permitting and compliance system known as 'Environmental Permitting'. (Further information on the Environmental Permitting Programme is available on the Defra website, <http://www.defra.gov.uk/environment/policy/permits/index.htm>.)

- a) The disposal of radioactive waste requires a permit under *The Environmental Permitting (England and Wales) Regulations 2010* (EPR 10) (previously, an authorisation under *The Radioactive Substances Act 1993* (RSA 93) was required).
- b) The discharge of aqueous effluents (such as from cooling or dewatering during construction) requires a permit under EPR 10 (previously, a consent under *The Water Resources Act 1991* (WRA 91) was required).
- c) Some conventional plant (for example, combustion plant used as auxiliary boilers and emergency standby power supplies, and incinerators used to dispose of combustible waste) may require a permit under EPR 10 (before 1 April 2008, a permit under *The Pollution Prevention and Control Regulations 2000*, Statutory Instrument 2000 No. 1973 (PPC 00) may have been required).
- d) The disposal of waste by depositing it on or into land, including excavation materials from construction, and other waste operations may require a permit under EPR 10 (before 1 April 2008, a permit under PPC 00 or a licence under part II of *The Environmental Protection Act 1990* may have been required).
- e) The abstraction of water (for example for cooling or process use) from inland waters or groundwater, except in some specific circumstances, requires a licence under WRA 91. Inland waters include rivers, ponds, estuaries and docks, amongst others.

99 The Environment Agency and HSE together form the competent authority for *The Control of Major Accident Hazards Regulations 1999*, Statutory Instrument 1999 No. 743 (COMAH 99). On-site storage of certain substances in large quantities may fall under these regulations.

- 100 Based on our past experience, permitting the disposal of radioactive waste is the area of regulation that has the highest profile, the greatest perceived uncertainties and the longest lead-time for our permitting of new nuclear power stations. For those reasons, our GDA focuses mainly on radioactive waste issues, although we also look at aspects of the design that relate to other regulatory issues.
- 101 New nuclear power stations are likely to need new or enhanced flood defence structures. A flood defence consent will be needed to construct these but, as flood defence is necessarily site-specific, we have not considered this matter during GDA. HSE also considers flooding when assessing the safety of a nuclear reactor against external hazards.

4 The AP1000 design

102 This section provides a brief outline of the AP1000 design and how it is proposed that waste will be created, processed and disposed of.

4.1 Outline of design

103 The AP1000 design is a single, pressurised water reactor (PWR) capable of generating nominally 1117 megawatts (MW) of electricity, with a claimed 60 year design life. AP stands for 'advanced passive', as it is claimed that the AP1000 uses passive safety systems such as natural circulation and gravity. Westinghouse claims that the AP1000 safety systems are designed to mitigate the consequences of plant failures, ensuring the reactor shuts down, decay heat is removed, and releases of radioactivity are prevented. In the reactor core, the uranium oxide fuel (enriched up to 4.95 per cent of uranium-235) is cooled by water in a pressurised circuit, the primary circuit. This water also acts as the neutron moderator necessary for a sustained nuclear fission reaction. The primary circuit includes two steam generators where heat is transferred from this primary coolant circuit to a secondary circuit, producing steam. This steam then drives a turbine-generator to produce electricity, is condensed, and the condensate returned to the steam generators.

104 The AP1000 is a plant design incorporating six buildings (see Figure 4.1 below from the ER). The design comprises the nuclear island (containment/shield building, and auxiliary building), annex, diesel generator, turbine generator, and radwaste buildings. The main ancillary facilities include a spent-fuel storage pool, water treatment systems for maintaining the chemistry of the primary and secondary water circuits, two diesel generators for providing power in the event of loss of grid supplies, and waste treatment and storage facilities. For the purpose of generic design assessment, turbine condenser cooling water is provided by a once-through system using seawater.

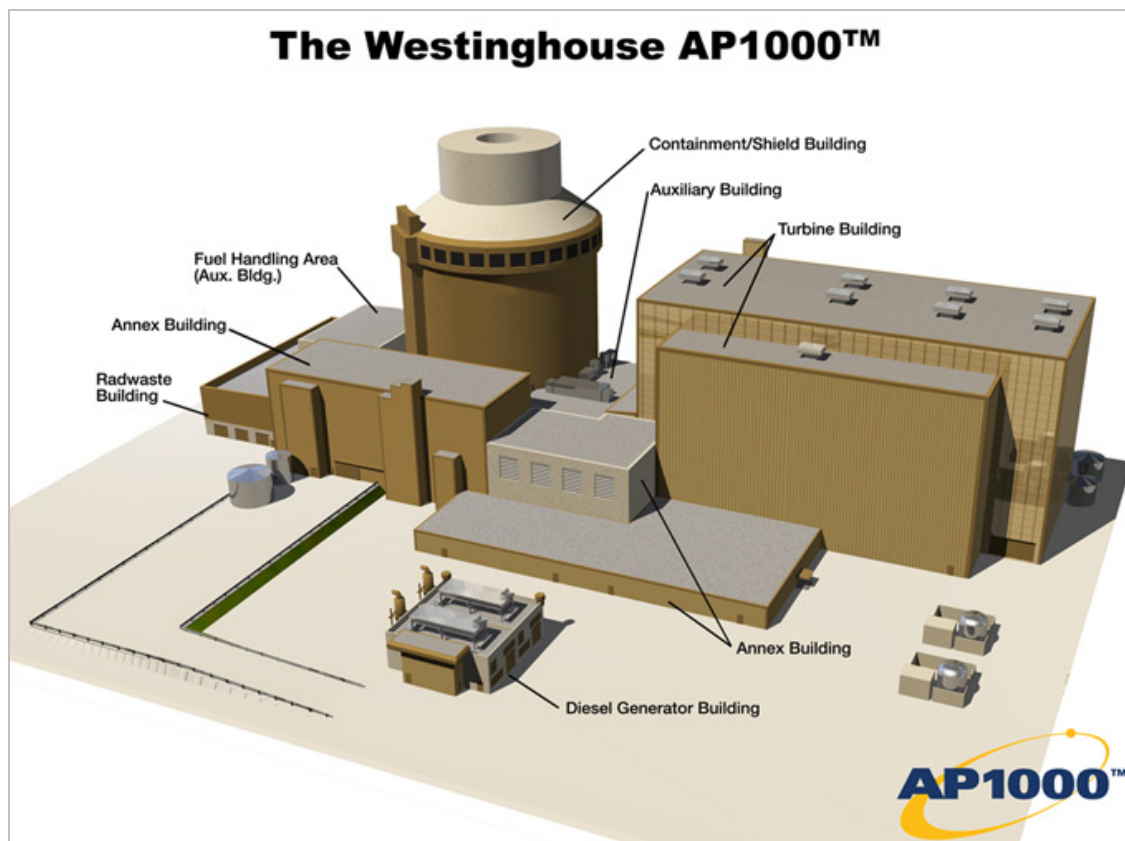

Figure 4.1: AP1000 Schematic (Environment Report Figure 2.3-1)

105 The AP1000 has evolved from earlier Westinghouse Electric Company LLC PWR designs, the most recent of which is the AP600. The Sizewell B reactor is the only operating PWR in the UK and is a Westinghouse design. The current AP1000 design is undergoing regulatory review by the nuclear regulator in the USA, the Nuclear Regulatory Commission (NRC). The AP600 achieved Design Certification in 1999 from US NRC but was never constructed. AP1000 maintains the AP600 configuration and the US licensing basis by limiting the design changes. There are currently a number of applications for combined construction and operating licences in the US for AP1000. These have to be assessed, and design approval given by US NRC before any construction is permitted. Four AP1000 plants are already under construction in China – two at Sanmen and two at Haiyang. Westinghouse and China are currently discussing plans for additional AP1000 plants to be sited inland of China's coastal areas. Additionally, Westinghouse and the AP1000 have been identified as the supplier and technology of choice for no less than 14 plants that have been announced in the United States, including six for which engineering, procurement and construction contracts have been signed. The AP1000 is certified by the U.S. Nuclear Regulatory Commission, and is the only Generation III+ reactor to receive such certification. The European Utility Requirements (EUR) organisation also certified that the AP1000 is compliant with European Utility Requirements, confirming that the AP1000 can be successfully used in Europe.

4.2 Sources, processing and disposal of radioactive waste

106 Radioactive waste would be produced by activities associated either directly or indirectly with operating and maintaining the reactor, and ultimately, from decommissioning the plant. In particular, operating a PWR generates radioactive substances in the water of the primary coolant circuit, which are subsequently transferred to waste items.

107 Discharges of radioactive waste dissolved or carried in water (aqueous discharges) are produced mainly from effluents associated with systems for collecting and treating the primary coolant water. Other sources of effluent include the fuel pool purification system, washings from plant decontamination, and drainage (detergent waste) from change-rooms. The detergent waste activity is monitored, and if it is sufficiently low, then it is discharged without processing. Effluent treatment facilities include accumulation, hold up and monitoring tanks; filters; and demineraliser ion exchange resin beds. Facilities to sample and monitor aqueous wastes before they are released are provided. Final discharge is to the sea combined with the cooling water.

108 The main source of gaseous radioactive discharges is the gaseous component arising within the coolant circuit which is collected by the gaseous radwaste system (GRWS) and held for decay storage in the activated carbon bed delay system. The system includes a gas cooler, a moisture separator, an activated carbon-filled guard bed, and two activated carbon-filled delay beds. The gaseous waste from the delay bed passes through a radiation monitor and discharges to the ventilation exhaust duct. Gaseous activity will also be present in the main process buildings, which are serviced by the heating, ventilation and air-conditioning (HVAC) systems. Discharges from these systems to air are through a stack located on the top of the nuclear island. There is provision for monitoring these discharges after filtration through high efficiency particulate air (HEPA) filters and, where appropriate, charcoal adsorption. There is also the possibility of tritium in the secondary circuit from minor leaks from the primary circuit. This is collected in the condenser air removal system. There are provisions for sampling and monitoring gaseous wastes at various points in the gaseous radwaste system.

109 Other radioactive waste created by the AP1000 includes spent ion exchange resins, and deep bed filtration media, spent filter cartridges, worn-out plant components and parts, contaminated protective clothing and tools, rags and tissues, and waste oil.

- This waste is collected by the solid waste management system where decay storage or basic conditioning is carried out to enable off-site disposal.
- 110 Westinghouse Electric Company LLC does not expect that any novel solid waste streams will be generated by the AP1000. Most solid low level radioactive waste (LLW) will meet the appropriate criteria for disposal at the UK National LLW Repository (LLWR) near Drigg in Cumbria.
- 111 All radioactive plant components are likely to become waste when the plant is decommissioned. The strategy for disposing of decommissioning waste will be provided in further information, as noted elsewhere in this document.
- 112 Spent fuel will be stored under water for about 18 years in the spent-fuel storage pool. The options for longer term management are described later in this document.

4.3 Non-radioactive waste

- 113 Non-radioactive waste is produced from operating and maintaining the plant. It includes:
- a) combustion gases discharged to air from the diesel generators;
 - b) water containing water-treatment chemicals, from the turbine-condenser cooling system and other non-active cooling systems, which is discharged to sea;
 - c) waste lubricating oils;
 - d) screenings from sea inlet filters;
 - e) worn-out plant and components and general rubbish.
- 114 Non-radioactive substances will also be present in the radioactive waste and may affect how that waste is managed or the impact it has on the environment. For example, aqueous radioactive discharges will contain boron compounds. Boron (a neutron absorber) is added to the primary coolant circuit to help control reactivity in the core.

5 Guide to our detailed assessment

115 In the following chapters (6 -15), we set out our preliminary conclusions (subject to the outcome of this consultation), and our consultation questions followed by our detailed assessment for:

- a) Management Systems (chapter 6);
- b) Radioactive Substances Regulation
 - i) Integrated Waste Strategy (chapter 7)
 - ii) Best Available Techniques to minimise production of radioactive waste (chapter 8)
 - iii) gaseous radioactive waste disposal and limits (chapter 9)
 - iv) aqueous radioactive waste disposal and limits (chapter 10)
 - v) solid radioactive waste (chapter 11)
 - vi) spent fuel (chapter 12)
 - vii) monitoring of radioactive disposals (chapter 13)
 - viii) impact of radioactive discharges (chapter 14);
- c) other environmental regulations (chapter 15).

116 Our conclusions, all of which should be considered preliminary pending the outcome of this consultation:

- a) identify any matters that would be GDA Issues attached to our statement of design acceptability, if we decide to issue one. These GDA Issues may be due to:
 - i) Westinghouse failing to provide enough information for our assessment (for example, because an aspect of the design is not complete);
 - ii) a technical issue raised by our assessment not being fully resolved or confirmed.
- b) identify any other issues that would need to be cleared at an appropriate point during the reactor procurement, design development or construction programme. The other issues may relate to:
 - i) matters that are normally addressed during the construction or commissioning phase of a plant (for example, demonstration that as-built plant realises the intended design);
 - ii) matters that depend on site-specific characteristics.

117 Our detailed assessment took account of the legal and policy issues set out in our considerations document (Environment Agency, 2009c), where practicable at the generic level. Our considerations document was superseded with the introduction of the Environmental Permitting Regulations (EPR 10) in April 2010 and the issue of related guidance documents. We will review our assessment against the EPR 10 guidance before we publish our final decision in June 2011.

118 As part of our agreed GDA process with the RPs, we agreed a mechanism for raising concerns and/or requesting further information. This mechanism works on a tiered approach depending on the severity of our concern:

- a) **Technical Query (TQ):** A request for clarification or further information resulting from the inspection/assessment process. A Technical Query is not a Regulatory Observation or a Regulatory Issue, but may result in an Observation or Issue being raised by the Regulators to the requesting party where the query cannot be satisfactorily resolved.

- b) **Regulatory Observation (RO)**: An assessment finding that requires further justification by and/or discussion with the requesting party and further assessment by the Regulators in the expectation that it can be resolved to the satisfaction of the Regulators. A Regulatory Observation that has not been satisfactorily resolved may, at the discretion of a regulator, be converted to a Regulatory Issue (RI).
- c) **Regulatory Issue (RI)**: In the judgement of the regulators a finding or concern for which, for the design submitted and the mode of operation proposed, the requesting party has not demonstrated (or may not be able to demonstrate) that risks will be reduced as low as reasonably practicable (ALARP), or that regulatory requirements are met, or that the best available techniques (BAT) will be used to minimise the arisings and impact of conventional and radioactive waste, and which is important enough that it would prevent GDA being successfully completed or lead to a GDA Issue.
- 119 We found that the initial submission did not contain the level of information we needed to carry out a detailed assessment. We raised a Regulatory Issue on Westinghouse and it committed to providing further information. Westinghouse provided a completely revised submission, its 'environment report' (ER) with supporting documents. It has published the ER and other documents on its website (<https://www.ukap1000application.com>).
- 120 During our assessment of the ER, we had some concerns and needed some additional information. We raised nine ROs and 42 TQs on Westinghouse, some of which were joint with HSE. The responses to these ROs and TQs were incorporated into revisions of the ER and some additional supporting documents, as now available on the website noted above.
- 121 We are now consulting on the outcome of our detailed assessment of the information contained in the revised submission. The documents comprising the submission are listed in Annex 5. We reference most frequently to the following documents:
- a) Environment report (ER);
 - b) Pre-construction safety report (PCSR);
 - c) AP1000 integrated waste strategy document (IWS);
 - d) AP1000 nuclear power plant BAT assessment (AP1000 BAT);
 - e) AP1000 European design control document (DCD).
 - f) Design reference point - currently under definition by Westinghouse in discussion with the regulators (as at June 2010).
- 122 More details of our assessment can be found in our assessment reports. These are listed in Annex 1 (Schedule 3).
- 123 The White Paper on Nuclear Power (BERR, 2008a, paragraph 2.87) states that:
- ‘The environment agencies will ensure that radiation exposure of members of the public from disposals of radioactive waste, including discharges, are as low as reasonably achievable (ALARA) by requiring new nuclear installations to use the best available techniques (BAT) to meet high environmental standards. This will help ensure that radioactive wastes created and discharges from any new UK nuclear power stations are minimised and do not exceed those of comparable power stations across the world.’
- 124 Annex 3 of this Consultation Document presents an analysis of discharge data from predecessor nuclear power stations, so that we can make a comparison with the predicted discharges from the AP1000. However, it is important not to draw comparisons too closely as there are many uncertainties in the datasets. For example, the published results:

- a) are the results of measurement - albeit to differing standards, or are derived from calculations of predicted discharges;
- b) treat limits of detection in different ways;
- c) are taken from reports in differing formats; and,
- d) should not be compared with other data without establishing how those were obtained and reported e.g. Germany only requires the measuring and reporting of carbon-14 in CO₂ form

125 The public involvement process has been available throughout our assessment. We addressed those comments we received before 4 January 2008 in our preliminary assessment report. We have considered comments we received since then during our detailed assessment, and refer to these in the relevant sections of chapters 6 – 15.

126 We set out our overall preliminary conclusion on design acceptability in chapter 16.

6 Management systems

127 We conclude that Westinghouse has an appropriate management system in place to:

- a) control the content and accuracy of the information provided for GDA;
- b) maintain records of design and construction;
- c) control and document modifications to the design.

128 However, there remain outstanding matters for Westinghouse to resolve and close out during GDA in agreement with the Regulators. Westinghouse recently submitted a letter to the JPO on 14 April 2010 in regard to its quality assurance (QA) improvement plan including specific commitments. We will review this information and continue with the planned meeting programme on QA issues with Westinghouse. Thus, the following reservation needs to be resolved and closed out by Westinghouse to the satisfaction of the UK Joint Regulators before the end of GDA:

- a) Westinghouse has still to demonstrate to the UK Regulators the application of the full rigours of its Quality Management System (QMS) to the UK GDA project.

129 During its Step 4 review, HSE intends to examine the application of the full breadth and depth of the Westinghouse QMS applicable to the UK GDA project. HSE proposes to carry out one or more targeted inspections to establish Westinghouse's consistent and comprehensive application of adequate quality assurance arrangements. The Environment Agency will continue to work closely with HSE on this matter and, our decision document will be informed by this work.

130 We conclude that Westinghouse has adequately specified:

- a) its expectations for any operating utility's management system;
- b) how it expects to transfer knowledge and provide continuing support to any operating utility.

Consultation question 1: Do you have any views or comments on our preliminary conclusions on management systems?

6.1 Westinghouse's management system

131 We examined Westinghouse's management system in some detail during our preliminary assessment in 2007-8, and concluded that it was suitable for controlling the content and accuracy of the information Westinghouse has provided to us for GDA (Environment Agency 2008a). There were, however, some matters that we felt could be improved and we made recommendations for improvement during our joint regulators' inspection in 2007 for Westinghouse to consider.

132 Westinghouse documented the joint regulators' November 2007 inspection recommendations as issue reports in its corrective action programme (CAPs), using its QMS. Westinghouse responded formally with a commitment to implement these recommendations and to provide us with an update on progress. Westinghouse's progress in relation to implementing the recommendations is summarised below:

- a) Recommendation 1: a formal project quality assurance plan has been produced for the UK project. This document is, at the time of writing this consultation document, being revised following review comments by the joint regulators.
- b) Recommendation 2: Westinghouse produced a formal history documenting the development of the AP1000 design.

- c) Recommendation 3: Westinghouse produced a training module for staff working on the UK project and implemented training for the staff.
 - d) Recommendation 4: Westinghouse created and implemented a formal learning organisation to capture and communicate learning from operating experience.
 - e) Recommendation 5: Westinghouse provided further information on waste strategy and decommissioning in its submission documents. This matter is addressed elsewhere in this consultation document.
- 133 Our conclusion is that Westinghouse responded to the joint regulators' recommendations made in 2007, and worked positively to take on board some of our recommendations for improvement. For example, the creation of an organisational learning section in Westinghouse.
- 134 During the detailed assessment stage, we have kept Westinghouse's management arrangements under review. Our assessment of management arrangements has involved reviewing Westinghouse's GDA submissions and arrangements for quality management, in particular the overarching project quality plan and supporting procedures. A significant part of our assessment activity has involved inspection to review the application of Westinghouse's arrangements to the UK GDA project, and to identify evidence that it has effectively implemented arrangements.
- 135 Our review of Westinghouse's GDA submissions found that its QMS (October 2002) describes Westinghouse's commitments to the quality assurance requirements of recognised international standards and are externally audited. The quality plan developed for UK GDA sets out the detail of how Westinghouse's QMS is applied to the UK project. The project quality plan is supported by procedures that have been developed for the UK GDA project. The regulators reviewed the plan and procedures and provided formal comments to Westinghouse in May 2009 following our inspection in March-April 2009. The revised quality plan was provided to the Regulators on 5 March 2010. A further revision is due in April 2010. The revisions by Westinghouse to the UK GDA procedures are due to be completed in April 2010.
- 136 A joint regulators inspection of Westinghouse's management arrangements was arranged for March 2009 to follow up progress on implementing the recommendations from our initial inspection in November 2007. The inspection was also carried out to assess whether Westinghouse was applying its quality management systems to the UK GDA project, namely to establish that Westinghouse has implemented and continues to review arrangements that control its GDA related activities. The inspection focused on and re-examined the arrangements for controlling modifications to the AP1000 design; configuration control for GDA submission documents and arrangements for transmitting of submission documents to the regulators; internal, external and third party certification audits; learning from experience, and procurement arrangements.
- 137 The joint regulators made a number of recommendations that they discussed with Westinghouse during the 2009 inspection. The joint regulators' inspection report was published in 2009 and can be found at <http://www.hse.gov.uk/newreactors/reports.htm>.
- 138 The joint regulators' conclusion from the inspection was that:
- a) Westinghouse continues to operate a well-developed set of quality arrangements that include sub-tier procedures that are periodically reviewed and audited.
 - b) A GDA specific quality plan was developed, supported by a number of related GDA procedures, that are designed to formalise the interface between the Joint Programme Office (JPO) and Westinghouse.
 - c) The inspection team considers that the joint regulators' confidence in the arrangements for the remainder of GDA could be improved by applying all the elements of the Westinghouse quality programme to the UK GDA project.

- d) It is acknowledged that Westinghouse has experienced and knowledgeable staff and a commitment to retain adequate technical resources. Westinghouse has established a number of targeted initiatives that have addressed organisational learning and continuous improvement. However, the full benefit of these initiatives has not been realised for the UK GDA project as the level of application to the project appears to be minimal. This leads to some doubt regarding the effective application of Westinghouse processes to the UK GDA project.
- 139 We issued Regulatory Observations following our inspection in March and April 2009 on areas where we required Westinghouse to carry out specific work. We issued a Regulatory Observation, RO-AP1000-35, requiring Westinghouse to demonstrate that it is applying the full rigour of its QMS to the UK GDA project.
- 140 The regulators have made a number of comments and recommendations about quality management issues relating to the submission documents they have received to date during GDA. These reflect the issues noted in part c) above regarding applying all elements of the Westinghouse QMS to the UK GDA project.
- 141 We had previously issued a Regulatory Observation, RO-AP1000-17 UK GDA Quality Assurance Processes, concerning Westinghouse applying quality management arrangements specifically to GDA submission documents. Following our inspection, the Regulators issued comments on Westinghouse's quality plan and procedures for the UK GDA project. These were issued in the form of two additional regulatory observation actions to RO-AP1000-17 in May 2009 requiring Westinghouse to update, revise and implement the plan and procedures for UK GDA. The revised plan was provided in March 2010 and a further revision is due in April. The revised procedures are due in April 2010. This is out with the timescale for detailed consideration in this document. We will consider this information in detail later in our decision document, taking into account HSE's review findings, including its planned inspection of management systems in Step 4 for GDA.
- 142 We issued a further Regulatory Observation, RO-AP1000-33, in regard to quality issues for the environment report submission. Westinghouse responded to RO-AP1000-33 and produced a revised environment report in December 2009 to address the quality issues in the previous report. The regulators undertook a review of the report, and wrote to Westinghouse in March 2010 to advise the issues had been addressed and the observation was closed.
- 143 Westinghouse provided a detailed response to RO-AP1000-35 on 31 August 2009 and the response was discussed at a meeting between Westinghouse and the Regulators on 10 September 2009. Its response provided information on the application of Westinghouse quality procedures to the UK GDA project. As an example of the application of Westinghouse's QMS, Westinghouse carried out an internal audit of AP1000 International Projects in 2009 which included the UK GDA project. Two self assessments of the UK GDA project were planned and due for completion in September 2009. A further update response to RO-AP1000-35 was provided by Westinghouse letter of 26 October 2009. This included an attachment specifically to advise on how the Westinghouse QMS applies to UK GDA and also provided details of an audit of the UK GDA Project Quality Plan for compliance with Westinghouse QMS.
- 144 Westinghouse discussed details of its progress in implementing the 2009 inspection recommendations at a progress update meeting with the joint regulators in September 2009. Further meetings were held in 2010 between the regulators and Westinghouse to discuss progress on QA matters, and Westinghouse provided a formal response on all QA issues including Regulatory Observations RO-AP1000-17, RO-AP1000-33 and RO-AP1000-35, by letter of 11 March 2010. The response contained a series of documents and attachments. These were received too late for consideration in this document and will be given detailed consideration in preparing our decision document.
- 145 Discussions were held between the regulators and Westinghouse at a meeting on 1 April 2010 in regard to the 11 March response from Westinghouse. It was agreed at

the meeting that a commitment letter outlining the work programme for Westinghouse to close out any remaining QMS issues during GDA would be provided by Westinghouse on 14 April 2010. Westinghouse provided a letter response and programme detailing its quality assurance improvement plan, including commitments to applying the full suite of its QMS procedures to the UK GDA project on 14 April 2010. Further meetings are planned between the regulators and Westinghouse to ensure that remaining QA matters are closed out satisfactorily by Westinghouse during GDA.

146 In conclusion, the regulators note that Westinghouse has strong management systems in place at its US Head Office, and we have seen evidence that these systems are being implemented effectively across US operations. Westinghouse has made progress in applying its management arrangements to the UK GDA project with an internal audit and two self assessments carried out in 2009 for the UK GDA project, and the inclusion of the GDA project in its organisational learning programme. A further internal audit of the UK GDA project is scheduled for 2010. Westinghouse is developing a UK based organisation for AP1000 with supporting management systems specific to the UK.

147 We will consider the 11 March response information in detail, and the revised quality plan and procedures for GDA, and the Quality Assurance Improvement Plan from Westinghouse. We will continue to liaise with HSE on these matters, taking into account HSE's review findings, including its planned inspection of management systems in Step 4 for GDA. Our findings will be detailed in our decision document.

148 In conclusion, some progress has been made by Westinghouse and we have seen evidence that Westinghouse's QMS has been applied to the UK GDA project. Westinghouse recently submitted a letter on 14 April 2010 in regard to its quality assurance improvement plan including specific commitments. We will review this information and continue with the planned meeting programme with Westinghouse over the next 12 months. Thus, the following reservation needs to be resolved and closed out by Westinghouse to the satisfaction of the UK Joint Regulators before the end of GDA:

- a) Westinghouse has still to demonstrate to the UK Regulators the application of the full rigours of its Quality Management System (QMS) to the UK GDA project.

6.2 Expectations for the operator's management system

149 Before a site-specific application for an AP1000 can be made, the potential operator will need to begin establishing its management system, including organisational structure and resources, and there will need to be considerable knowledge transfer about the design. We, therefore, need a requesting party to address, in its GDA submission, the implications of the design for the potential operator's management system, and how it intends to transfer the necessary information and provide ongoing support to the potential operator.

150 Reference 1.1 of Table 1 of our process and information document for GDA requires Westinghouse to set out its expectations of the operator's management system to cover the reactor's operations throughout its lifecycle. The regulators asked Westinghouse to provide further information in TQ-AP1000-330, specifically, to address in its GDA submission, the implications of the AP1000 design for the potential operator's management system. In particular, how Westinghouse intends to transfer the necessary information about the AP1000 design, and the arrangements to provide ongoing support to the potential operator. Westinghouse developed its proposals in liaison with its utility partners, and we welcome their involvement.

151 Westinghouse's submission addresses these matters in:

- a) AP1000 Pre-Construction Safety Report PCSR, Chapter 9

- b) Plant Life Cycle Safety Report
 - c) UK AP1000 Environment Report Section 1.4 Management System
 - d) Plant Operations, Surveillance, and Maintenance Procedures
- 152 The operator is required to establish a design authority, with arrangements in place to make sure that enough information and knowledge about the design is transferred from Westinghouse, as the design organisation, to the operator so that it can act as an effective design authority.
- 153 PCSR Chapter 9, Safety Management throughout the Plant Lifecycle notes “Westinghouse will ensure that design and operational knowledge is transferred to the licensee of the operating organisation in order to permit it to perform as an intelligent customer. This knowledge transfer include the provision of design information and comprehensive training and education programmes such that the licensee can establish a credible design authority”. Westinghouse recognises the importance of transferring the design authority role to the operating organisation. It also recognises the importance of training and development during the design phase for licensee personnel in regard to AP1000.
- 154 Westinghouse is continuing to develop the Plant Life Cycle Safety Report, LCSR and submitted a new revision in March 2010, following a meeting with the Regulators in December 2009. The report describes the arrangements for the overall AP1000 GDA project and the requirements and provisions for different phases from design through to decommissioning. It will include a safety and quality philosophy, and incorporate issues such as developing an ‘intelligent operator’ (we use the term to describe the capability of an operator to have a clear understanding and knowledge of the reactor design being supplied), It will also include organisational arrangements for moving to an operational regime with information on procedures, training and records.
- 155 Westinghouse provided a copy of the plant operations, surveillance and maintenance procedures for the AP1000. This document includes listings of emergency operating procedures, normal operating procedures and abnormal operating procedures that will be required to operate the AP1000.
- 156 Westinghouse has agreed with their potential utility customers that the submissions it makes to the regulators during GDA will describe the management of the process to cover vendor expectations of the operator’s management arrangements, and interactions between the vendor and operator, before any site licence application is made.
- 157 Westinghouse has an established design procedure that includes a thorough design review process. The process is described in the Life Cycle Safety Report. Robust design change procedures are in place to assess and control the effect of design changes on safety and these were discussed with the joint regulators during the 2007 and 2009 inspections.
- 158 Westinghouse sets out its expectations for a potential operators management system where safety and environment may be impacted. It gives an overview of those aspects of the management arrangements where transfer of information, education or continued support will be necessary to ensure safe and environmentally sound operations. The arrangements for transferring knowledge and retaining competence are set out. Westinghouse states that knowledge transfer will be systematically carried out starting from the arrangements in place during GDA. This includes involving the utility partners who play an active role in review and input to the environment and safety submissions. The utility partners have formed the AP1000 GDA Submission Steering Committee (AGSSC) to input, review and comment on GDA submissions for AP1000. In this respect, the process of knowledge transfer in regard to the design is occurring. Further information on knowledge and information transfer to the operator in regard to the AP1000 design is provided in the March 2010 update to the LCSR.

7 Integrated waste strategy

159 We have concluded that:

- a) Westinghouse has provided a reasonable radioactive waste and spent fuel strategy for all waste streams that an AP1000 will typically produce.
- b) The radioactive waste and spent fuel strategy is consistent with recent government statements (BERR, 2008a).

160 However, our conclusion is subject to the following potential GDA Issue:

- a) Decommissioning of the AP1000 (AP1000-I1).

Consultation question 2: Do you have any views or comments on our preliminary conclusions on the radioactive waste and spent fuel strategy?

161 We expect new nuclear power plant designs to be developed in line with a radioactive waste and spent fuel strategy that seeks to:

- a) minimise the production of radioactive waste;
- b) manage unavoidable waste and spent fuel to achieve an optimal level of protection for people and the environment.

162 Our radioactive substances regulation environmental principles (Environment Agency 2010c) (REPs) set out the issues that this type of strategy should take into account. For new nuclear power plant designs, the strategy also needs to be consistent with recent government statements (BERR 2008a) that:

- a) the disposal of intermediate level radioactive waste (ILW) to a future geological repository, from any new nuclear power stations, is unlikely to occur until late this century;
- b) any nuclear power stations that might be built in the UK should proceed on the basis that spent fuel will not be reprocessed.

7.1 Westinghouse's integrated waste strategy

163 Westinghouse's integrated waste strategy (IWS) outlines its current strategy for managing radioactive and non-radioactive waste, including spent fuel arising from operations and decommissioning for the AP1000. The IWS does not include waste from construction activities. The IWS is a companion document to the UK AP1000 environment report and the radioactive waste management case (RWMC) evidence reports for ILW and High Level Waste (HLW).

164 A schematic of the AP1000 waste management strategy can be found in Figure 3.5-1 of the ER.

165 Westinghouse's IWS states that it relates to all waste and all material that could become waste, both radioactive and non-radioactive. It claims in its IWS that the requirements of the waste management hierarchy are inherent in many aspects of the AP1000 design. It also claims that it has not identified any waste that is incompatible with current or developing disposal techniques.

166 Westinghouse claims in its ER that its IWS is consistent with the key BAT management factors for optimising releases from nuclear facilities shown in Table 3.1-1 in the ER. One of these factors stated by Westinghouse is to 'concentrate and

- contain environmentally persistent or bio accumulative emissions'. Features of the AP1000 design that address this factor have been added to Table 3.1-1. (The 'concentrate and contain' option involves trapping the radioactivity in a solid, concentrated form for storage and eventual disposal rather than the 'dilute and disperse' option which involves the direct discharge of gaseous or liquid radioactivity into the environment, DECC, 2009a).
- 167 In 2006, the Government's response to recommendations by the Committee on Radioactive Waste Management (CoRWM), established that, in England and Wales, deep geological disposal is the preferred route for the long-term management of radioactive waste that is not suitable for near-surface disposal. It also gave the responsibility for implementing the programme for a deep geological repository to the Nuclear Decommissioning Authority (NDA). To take this into account, HSE, the Environment Agency and the Scottish Environment Protection Agency (SEPA) have developed a series of joint guidance documents on the management of higher activity radioactive waste (available at <http://www.hse.gov.uk/nuclear/wastemanage.htm>). These specify the production, content, maintenance and review of radioactive waste management cases (RWMCs). The RWMC should demonstrate the long-term safety and environmental performance of the management of higher activity radioactive waste from generation to conditioning into a form that will be suitable for storage and eventual disposal. Westinghouse provided two documents - one for ILW and one for HLW - that it claims demonstrate that suitable RWMCs can be prepared by the site licensee in the future.
- 168 Westinghouse states in its IWS that its strategy for LLW is to collect and transfer it to its radwaste building where it will be sorted and segregated and, wherever possible, decontaminated. It also states that the AP1000 design features and operating regimes will reduce the volumes of LLW generated. Westinghouse expects that the future utility operator will dispose of LLW to the LLWR.
- 169 Westinghouse states in its IWS that the AP1000 design minimises the production of ILW. Its strategy for dealing with ILW is to process the waste into a stable form using mobile facilities and then to store onsite in the ILW store. It will be disposed of to the ILW repository when it is has been developed.
- 170 Westinghouse states in its IWS that its strategy relating to radioactive liquids is to treat them to reduce activity, using BAT as much as practicable, and to discharge to the environment following a suitable monitoring period.
- 171 Westinghouse states in its IWS that its strategy relating to radioactive gaseous discharges is to treat as much as practicable using AP1000 systems, to monitor and release to the environment.
- 172 The ER is consistent with recent government statements (BERR, 2008a) as Westinghouse has stated in Section 3.5.8.2 that ILW will be stored on site until a national ILW repository becomes available.
- 173 The IWS takes into account statutory guidance concerning the regulation of radioactive discharges into the environment (DECC 2009a). In particular, Westinghouse has used the principle of 'concentrate and contain' in its AP1000 design.
- 174 **We have concluded that:**
- a) **Westinghouse has provided a reasonable radioactive waste strategy for all waste streams that an AP1000 will typically produce.**
 - b) **The radioactive waste strategy is consistent with recent government statements (BERR, 2008a).**

7.2 Spent fuel strategy specifics

- 175 Westinghouse's IWS outlines its current strategy for managing radioactive and non-radioactive waste, including spent fuel arising from various stages of the lifecycle for AP1000, such as operation and decommissioning.
- 176 Section 3.5.1 of the ER provides an overview of the IWS that Westinghouse has developed to ensure that radioactive waste and materials generated, including spent fuel, are managed to be compatible with anticipated future NDA facilities for disposal. Westinghouse has assumed that it will be able to use current practices for spent fuel packaging when the AP1000 is in operation as NDA has not been able to provide information on the spent fuel packages it will accept. These assumptions relate to container designs and sizes and acceptable waste forms for spent fuel assemblies. Westinghouse continues to liaise with NDA on these matters during the GDA process.
- 177 The strategy proposed by Westinghouse for managing spent fuel following its removal from the reactor, is to transfer the spent fuel to the spent fuel pool for storage and initial cooling for a period of around 18 years. The fuel would then be transferred to an interim spent fuel dry store until a geological disposal facility becomes available for direct disposal. More detailed information on new and spent fuel, including spent fuel management proposals is presented in chapter 12.
- 178 Westinghouse's proposals for interim dry spent fuel storage are based on the Holtec International HI Storm 100U underground system. There are a large number of independent spent fuel storage installations in the United States that are licensed and operating for dry spent fuel storage. These systems are also used in Europe to maintain the fuel in a dry inert atmosphere.
- 179 The IWS notes that there is a spent fuel interim store to store all spent fuel assemblies generated by the reactor until the end of this century before final disposal. The IWS includes assumptions that spent fuel will be declared as waste and will not be reprocessed, and that it will be stored on site and then disposed of to the geological disposal facility.
- 180 Interim storage may be required potentially beyond 100 years to cover the lifetime of reactor operations (including the final emplacement of fuel to interim storage, following an initial cooling period in a pool after reactor operations cease), the time to reduce the heat generation of the fuel, and the potential for refurbishment of the store(s).
- 181 The regulators requested further information about long-term storage. We note HSE is continuing to review this information in its Step 4 assessment. We will continue to work closely with HSE on this, and this work will inform our decision document.
- 182 Westinghouse provides information in the BAT report on the measures it has incorporated in the design and use of fuel materials, and reactor controls in order to retain activity in the fuel.
- 183 Westinghouse produced the RWMC evidence report to demonstrate how it could meet regulatory expectations, and identified the information required to produce the RWMC for spent fuel (HLW). The RWMC demonstrates the longer term safety and environmental performance of waste for the planned management from generation to conditioning to a form which will be suitable for storage and eventual disposal. The evidence report outlined more information on the plans for longer term interim spent fuel storage, and identified areas where more information was needed including future research requirements.
- 184 Information is provided in Westinghouse's IWS about decommissioning waste and specific features of the AP1000 plant that have been designed to facilitate decommissioning. The IWS notes the longer term interim spent fuel store will be decommissioned following transfer of spent fuel to the GDF, and provides some general information on decommissioning of the store.

- 185 The IWS is consistent with recent government statements (BERR,2008a) in relation to spent fuel, as Westinghouse has made the following assumptions:
- a) Spent fuel will be declared as waste and will not be processed.
 - b) Spent fuel will be stored on site followed by disposal to the proposed geological disposal facility (GDF) at the appropriate time.

186 **We have concluded that:**

- a) **Westinghouse has provided a reasonable strategy for managing spent fuel that will be produced by the AP1000.**
- b) **The spent fuel strategy is consistent with recent government statements (BERR, 2008a) and our REPs (Environment Agency, 2010c).**

7.3 Decommissioning specifics

187 In line with government policy (DTI 2004), we expect:

- a) the radioactive waste and spent fuel strategy to address decommissioning;
- b) the design to use the best available techniques to:
 - i) facilitate decommissioning;
 - ii) minimise decommissioning waste;
 - iii) minimise the impacts on people and the environment of decommissioning operations and the management of decommissioning waste.

188 Westinghouse claims that it has demonstrated the end of life activity of decommissioning, and has taken the current experience of decommissioning activities into account in the design and layout of the AP1000 in chapter 20 of its European DCD. It states that this enables the utility to develop a decommissioning strategy. Appendix 20A of the European DCD provides information on an AP1000 outline decommissioning plan. Westinghouse claims that this plan demonstrates the technical and practical feasibility of one method by which the AP1000 can be easily decommissioned. Westinghouse also provides information on decommissioning and end of life aspects in Chapter 16 of its PCSR.

189 Westinghouse states in its IWS that, within the design of AP1000, there are many features that facilitate the eventual decommissioning of the plant. For example:

- a) Reduced equipment numbers reduce the amount of waste that needs managing.
- b) Carefully selecting materials reduces activation of equipment and structure.
- c) Reduction in activated corrosion products by improved control of primary circuit water chemistry and suitable dosing regimes; for example, zinc acetate.

190 We note HSE are requesting further information from Westinghouse on decommissioning for consideration in its Step 4 assessment. We also expect further detailed evidence to be provided in GDA on decommissioning, as this would assist any future operator in providing a Decommissioning and Waste Management Plan for agreement by the Department of Energy and Climate Change (DECC) Secretary of State. (see BERR 2008b).

191 **We conclude that we require further detailed information on how the AP1000 is designed to facilitate decommissioning, minimise decommissioning waste and minimise the impacts on people and the environment of decommissioning operations. We will continue to work with HSE on this as part of its Step 4 assessment, and this work will inform our decision document. Therefore, our conclusion is subject to the following potential GDA Issue:**

- a) **Decommissioning of the AP1000 (GDA Issue AP1000-I1)**

8 Best available techniques (BAT) to minimise production of radioactive waste

192 We conclude that overall the AP1000 utilises the best available techniques (BAT) to prevent and minimise production of gaseous and aqueous radioactive waste:

- a) during routine operations and maintenance;
- b) from anticipated operational events.

193 However, our conclusion is subject to a potential GDA issue, and four other issues which will need to be addressed before or during site-specific permitting.

194 Potential GDA Issue:

- a) The radiologically controlled area ventilation system (VAS), and any other ventilation systems where there is potential for the release of radioactive waste to the atmosphere which do not have passive HEPA filtration as part of the design (AP1000-I2).

195 Other issues:

- a) The capability to include boron recycle in the AP1000 design shall be kept under review and a BAT assessment provided at site-specific permitting to demonstrate whether boron recycling represents BAT (AP1000-OI01).
- b) Detailed arrangements for the hand over between Westinghouse and future operators shall be provided at site-specific permitting, in particular with respect to matters that relate to the use of BAT to minimise radioactive discharges (AP1000-OI02).
- c) The suitability and availability of appropriate mobile equipment for waste which is not compatible with the aqueous radioactive waste system shall be demonstrated at site-specific permitting (AP1000-OI03).
- d) Information relating to providing secondary containment for the monitor tanks shall be provided at site-specific permitting (AP1000-OI04).

Consultation Question 3: Do you have any views or comments on our preliminary conclusions on best available techniques to minimise the production of radioactive waste?

196 In minimising and managing radioactive waste, we require that best available techniques (BAT) are applied so that new nuclear power station designs are capable of meeting high environmental standards (DECC 2009a). BAT replaces, and is expected to provide the same level of environment protection as, the previously used concepts of best practicable environmental option (BPEO) and best practicable means (BPM).

197 Identifying BAT is the result of a process of optimisation where minimising the generation and discharge of radioactive waste is balanced against the cost and benefits of further reductions. This process is not restricted to radioactive substances and their resulting doses, but also concerns:

- a) safety considerations (for example, protecting workers) and security;
- b) wider environmental considerations (for example, using energy and other resources, generating and disposing of conventional waste);
- c) social and economic considerations.

This optimisation approach ensures that the cost of applying techniques is not excessive in relation to the environmental protection they provide.

198 BAT needs to be used throughout a design and over many aspects. We have assessed BAT starting at the source of radioactivity (the reactor), the way in which radioactivity is processed into gaseous, aqueous and solid waste streams and how each of those streams is reduced and disposed of.

199 We will set disposal limits based on the use of BAT. The limits will be set at the minimum levels to permit normal operation and will include contingencies to allow for maintenance and relevant operational fluctuations, trends and events that are expected to occur over the likely lifetime of the plant. (Statutory Guidance (DECC 2009a) and our REPS (Environment Agency 2010c) RSMDP12).

8.1 Sources of radioactivity

200 This section describes the sources of radioactive materials in the AP1000 that will eventually become waste, and the techniques used to minimise the amount produced. We expect new nuclear power plants to be designed to use BAT to prevent radioactive waste being produced unnecessarily. Where waste is produced, we expect BAT to be used to minimise the amount generated. (Statutory Guidance (DECC 2009a) and our REPS (Environment Agency 2010c) RSMDP3)

201 Radioactive materials within the UK AP1000 are mainly (ERs3):

- a) fission products created in the fuel that may pass through the fuel cladding by diffusion or through leaks and enter the coolant;
- b) dissolved or suspended corrosion products or other non-radioactive materials in the coolant that can be activated by neutrons as the coolant passes through the reactor core.

202 Westinghouse provides information in its BAT assessment report for the following radionuclides or groups of radionuclides:

- a) tritium;
- b) carbon-14;
- c) nitrogen-16;
- d) strontium-90;
- e) iodine-131;
- f) caesium-137;
- g) plutonium -241;
- h) noble gases;
- i) other beta emitting particulate radionuclides which are produced by the activation of non-radioactive material. This group includes cobalt-58, cobalt-60, iron-55 and nickel-63.

203 We have provided a guide on how radioactivity is formed in a nuclear reactor and the nature and properties of the significant radionuclides in Annex 4.

204 We conclude that, in line with our considerations document, Westinghouse has identified those radionuclides which either:

- a) Contribute significantly to the amount of activity (Becquerel - Bq) in waste disposals;
- b) Contribute significantly to potential dose to members of the public;
- c) Indicate plant performance, for example where the levels of a radionuclide might increase in the event of a deviation from normal plant operation.

205 Information Westinghouse presented in the AP1000 BAT assessment report is summarised below.

8.1.1 Tritium

206 Tritium is one of the most abundant radionuclides present in the coolant and is created by (BAT assessment form 1):

- a) unavoidable ternary fission of the uranium fuel. The tritium formed is initially contained within the fuel cladding but may diffuse into the coolant. The rate of tritium released into the coolant depends on reactor power. Westinghouse claim that the zirconium fuel cladding (ZIRLO) used in the AP1000 is more effective at reducing diffusion than other cladding materials. Westinghouse uses a 10 per cent in-core tritium release to the coolant as the design basis, which results in producing 63 TBq of tritium per 18-month cycle. Westinghouse uses a two per cent release of tritium to the coolant as the best estimate of tritium production, which results in producing 13 TBq of tritium per 18-month cycle.
- b) activation of the boron which is used as a burnable absorber either in discrete burnable absorber rods or as integral fuel burnable rods. The tritium will be produced within the cladding and may diffuse into the coolant. Westinghouse predicts the amount of tritium produced this way will be 10 TBq per 18-month cycle (design basis) or 2 TBq per 18-month cycle (best estimate).
- c) activation of boron-10 which is present as boric acid in the coolant. Boron is used to control the reactivity of the reactor. Westinghouse claims the AP1000 uses two techniques to minimise the amount of tritium produced:
 - i) grey rod clusters for load following minimises the amount of coolant boron needed for reactor control and the need for changes to boron concentration (ERs3.2.8);
 - ii) burnable poisons (a boride coating or incorporation of gadolinium oxide within some fuel pellets) reduces the amount of boron required.

Westinghouse recognises that it is possible to use boric acid with an enriched boron-10 content to reduce the quantity of boron needed for reactor control, but it claims this has no effect on the quantity of tritium produced. Westinghouse predicts the amount of tritium produced by this method will be 27 TBq per 18-month cycle.

- d) activation of lithium-6 and lithium-7 present in the lithium hydroxide which is used for chemistry control of the coolant to offset the corrosive effect of boric acid. Westinghouse claims that using lithium hydroxide enriched to 99.9 per cent of lithium-7 in the AP1000 minimises production of tritium (lithium-6 produces greater quantities of tritium than lithium-7). Westinghouse predicts the amount of tritium produced by this method will be 6 TBq per 18-month cycle.
- e) activation of deuterium in the reactor coolant (deuterium is an isotope of hydrogen which is naturally present in water at 0.015 per cent). We accept that producing tritium from deuterium is unavoidable and there are no available techniques to minimise its production. Westinghouse predicts tritium produced by this technique will be 4 TBq per 18-month cycle.

207 Westinghouse provides an options appraisal for techniques to minimise production of tritium in its AP1000 nuclear power plant BAT assessment. In its assessment, Westinghouse considers using boron recycle as a technique to minimise the production of tritium. Westinghouse claims that whilst boron recycle systems reduce tritium discharges to the environment, there are disadvantages in terms of storing coolant over a cycle; a more complicated system; and an increase in plant and components to be disposed of at the decommissioning stage. These aspects conflict

- with the AP1000 design concept of simplicity. Additionally, Westinghouse claims that using boron recycle could have an impact on operator dose.
- 208 Westinghouse concludes that the following techniques are BAT to minimise tritium production in the AP1000:
- a) using lithium-7 rather than lithium-6;
 - b) using zirconium fuel cladding;
 - c) using grey rods.
- 209 Westinghouse predicts the total amount of tritium produced from an AP1000 to be 110 TBq per 18-month cycle (design basis) or 52 TBq per 18-month cycle (best estimate).
- 210 We consider that the techniques Westinghouse has considered for minimising the production of tritium in the AP1000 are comprehensive enough and represent feasible and proven techniques at this stage. However, we recognise that techniques may be developed in the future which may be worth considering.
- 211 We note that boron recycling is not included in the AP1000 design. Whilst we recognise that alternative techniques such as using grey rods and burnable poisons may be more cost effective than using enriched boron or boron recycling to minimise the amount of tritium produced at source, we believe that further information is needed to demonstrate that using natural boron (as opposed to enriched boron) is BAT with respect to tritium production. We consider that Westinghouse should continue to review the feasibility of including boron recycling in the AP1000 as part of its ongoing review of BAT.
- 212 **We conclude that Westinghouse has demonstrated that BAT is used to minimise the production of tritium in the AP1000. However we expect that the capability to include boron recycle in the AP1000 design is kept under review and a BAT assessment provided at site-specific permitting to demonstrate whether boron recycling represents BAT (other issue AP1000-OI01).**

8.1.2 Carbon-14

- 213 Carbon-14 is created by the following mechanisms (BAT Assessment form 2);
- a) Neutron activation of oxygen-17, which is a naturally occurring stable isotope of oxygen in the coolant. Westinghouse claims it minimises the production of carbon-14 by eliminating free oxygen in the coolant. Westinghouse predicts the amount of carbon-14 produced from oxygen-17 to be 552 GBq y⁻¹.
 - b) Neutron activation of nitrogen-14 dissolved in the coolant. The AP1000 uses lithium hydroxide to control coolant pH as opposed to hydrazine which contains nitrogen and is used in some other designs. Using lithium hydroxide instead of hydrazine reduces the amount of nitrogen in the coolant and the amount of carbon-14 produced by this mechanism. Westinghouse has considered using argon as the cover gas for the coolant water supply tanks to minimise the dissolution of nitrogen. This would make the systems more complex and costly, and Westinghouse do not consider the use of argon cover gas to be BAT for the AP1000. Assuming 15 ppm of nitrogen in the coolant Westinghouse predict the production of carbon-14 from nitrogen-14 to be 110 GBq y⁻¹.
 - c) The neutron activation of nitrogen-14 in fuel. Nitrogen-14 in the fuel is minimised during the fabrication process during which the fuel rods are pressurised with helium which expels nitrogen from the fuel.
 - d) Carbon-14 is produced by the neutron activation of oxygen-17 and nitrogen-14 in stainless steel structural materials. However, Westinghouse claims that the carbon-14 produced by these methods will remain in these materials.

214 Westinghouse provides an options appraisal for techniques to minimise production of carbon-14 in the AP1000 in its AP1000 nuclear power plant BAT assessment. Westinghouse concludes that the following techniques are BAT to minimise carbon-14 production in the AP1000:

- a) oxygen scavenging;
- b) control of nitrogen in fuel by use of helium pressurisation;
- c) pH control by lithium hydroxide;
- d) using electrodeionisation to remove dissolved carbon dioxide gas from the coolant.

215 Assuming 15 ppm nitrogen in the coolant Westinghouse predicts the total production of carbon-14 to be 662 GBq y⁻¹.

216 We consider that the techniques Westinghouse has considered for minimising the production of carbon-14 in the AP1000 are comprehensive enough and represent feasible techniques at this stage. However, we recognise that techniques may be developed in the future which may be worth considering.

217 **We conclude that Westinghouse has demonstrated that BAT is used to minimise the production of carbon-14 in the AP1000.**

8.1.3 Noble gases

218 Noble gas radionuclides such as krypton-85, krypton-85m, xenon-133 and xenon-133m are fission products and are produced by fission of the uranium in the fuel. They are normally contained within the fuel cladding. However, if there are any fuel defects, these gases can enter into the reactor coolant. (BAT assessment form 8).

219 Even though there may be no defective fuel pins, natural uranium contamination of core construction materials and the fuel cladding, as well as enriched uranium contamination of external cladding surfaces during manufacture can also be a source of fission products in the coolant during power operations. Noble gas radionuclides dissolved in the coolant will be removed by degassing in the chemical and volume control system (CVS) and sent to the gaseous radioactive waste system (WGS).

220 Westinghouse claims that fuel leak rate in operating plants similar to the AP1000 is much less than the AP1000 design basis value of 0.25 per cent which is used to estimate aqueous and gaseous radioactive waste discharges and that current fuel design has been improved, both in terms of the integrity of fuel rods and the robustness of the fuel assembly with respect to vibration of the rods within the assembly (ER s3.2.4).

221 Westinghouse concludes that minimising fuel defects in operation, using reactor operating regimes that minimise the likelihood of damage to the fuel, and the location and removal of leaking fuel pins during refuelling and removal is BAT to minimise noble gas production in the AP1000.

222 **We conclude that Westinghouse has demonstrated that BAT is used to minimise the production of noble gases from the fuel in the AP1000.**

223 Argon-41 is produced by the activation of natural argon-40 in air surrounding the reactor in the containment area. Westinghouse predicts that 1,300 GBq y⁻¹ of argon-41 will be produced in the AP1000. Argon-41 is collected by the ventilation system and discharged through the main vent without treatment.

224 **We conclude that, taking into account that the production of argon-41 is unavoidable, its short half life (109 minutes) and low radiological impact, it is not proportionate to assess BAT in detail for argon-41. Discharges of argon-41 will be monitored and measured with other noble gases at the main plant stack and the turbine building stack.**

8.1.4 Iodine radionuclides

- 225 Iodine radionuclides are formed in the fuel by fission and can be released into the coolant as a result of defects in the fuel. In addition fission of uranium found on fuel and other surfaces (tramp uranium) can undergo fission and iodine radionuclides can be released into the coolant.
- 226 We accept that there are no techniques to prevent the production of iodine radionuclides within the fuel pins (BAT Assessment form 5).
- 227 The majority of iodine radionuclides produced will form compounds and remain in the liquid phase of effluents from the CVS. A small fraction will remain as elemental iodine and will be degassed in the CVS and passed to the WGS. Any leaks from the primary coolant system could also result in iodine radionuclides being found in the containment atmosphere.
- 228 Westinghouse concludes that the following techniques are BAT to minimise iodine-131 (and other iodine radionuclides) production in the AP1000:
- a) Minimisation of fuel defects in operation – reactor operating regimes are used which minimise the likelihood of damage to the fuel and leaking fuel pins are located during refuelling and removed.
 - b) Control of uranium contamination on external surfaces of fuel (tramp uranium) in fuel manufacture and fabrication.
- 229 We consider that the techniques Westinghouse has considered for minimising the production of iodine-131 (and other iodine radionuclides) in the AP1000 are comprehensive enough and represent feasible and proven techniques.
- 230 **We conclude that Westinghouse has demonstrated that BAT is used to minimise the production of iodine-131 (and other iodine radionuclides) in the AP1000.**

8.1.5 Other radionuclides

- 231 **Nitrogen-16** - is produced by activation of oxygen-16 in the reactor coolant. There is no practicable way to reduce its formation. However, its short half-life of 7.13 seconds means that discharges to the environment will be insignificant. (BAT assessment form 3)
- 232 We consider that minimising the production of nitrogen-16 at source is mainly a matter for the HSE as the short half life of nitrogen-16 means its key impact is on occupational dose.
- 233 We do not consider nitrogen-16 further in our assessment.
- 234 **Strontium-90** is a fission product normally contained within the fuel cladding. If there are any fuel defects strontium-90 can enter into the primary coolant. Westinghouse has not carried out an optioneering assessment for preventing or minimising strontium-90 at source, but it does claim that minimising fuel defects is key to minimising the production of strontium-90. (BAT assessment form 4)
- 235 We consider that the production of strontium-90 is unavoidable however we recognise that techniques to minimise fuel defects which are used to minimise the production of other radionuclides will also minimise the production of strontium-90.
- 236 **We conclude that Westinghouse has demonstrated that BAT is used to minimise the production of strontium-90 in the AP1000.**
- 237 **Caesium-134 and caesium-137** are fission products normally contained within the fuel cladding. If there are any fuel defects caesium radionuclides can enter the primary coolant. Fission of uranium contamination in the reactor (tramp uranium) can also be a source of caesium-134 and caesium-137. Caesium is highly soluble and, if present in the coolant, will eventually be treated in the liquid radioactive waste

treatment system (WLS). Detecting caesium radionuclides in aqueous radioactive waste disposals provides a useful indication of fuel integrity.

238 Westinghouse concludes that the following techniques are BAT to minimise caesium-137 production in the AP1000 (BAT assessment form 6):

- a) Minimisation of fuel defects in operation – reactor operating regimes are used which minimise the likelihood of damage to the fuel, and leaking fuel pins are located during refuelling and removed.
- b) Control of uranium contamination on external surfaces of fuel (tramp uranium) in fuel manufacture and fabrication.

239 We consider that the techniques Westinghouse has considered for minimising the production of caesium-137 in the AP1000 are comprehensive enough and represent feasible and proven techniques and will also minimise the production of caesium-134.

240 **We conclude that Westinghouse has demonstrated that BAT is used to minimise the production of caesium-137 in the AP1000.**

241 **Activation products**

- a) **Cobalt-58** is formed by the activation of nickel-58, a stable isotope of nickel, which is a major constituent of the AP1000 steam generator tubes and the stainless steel used to fabricate the core and the reactor pressure vessel components. Westinghouse claims it minimises the potential for the creation of cobalt-58 in the AP1000 by:
 - i) specifying metals that resist the corrosive effect of the coolant thus reducing corrosion products available to be activated;
 - ii) only using nickel-based alloys where component reliability may be compromised by the use of other materials, for example the steam generator tubes;
 - iii) pre-passivation of the steam generator to develop a single, chromium-rich layer which reduces corrosion product release.
- b) **Cobalt-60** is formed by the activation of cobalt-59 in the reactor steel. Cobalt is also found in hard-wearing alloys (stellites) which may be used on hardfacing components. Westinghouse claims it has minimised the amount of cobalt-60 produced in the AP1000 by minimising the amount of cobalt bearing materials used in the design using the following techniques:
 - i) using low or zero cobalt alloys for hardfacing materials in contact with coolant unless necessary for reliability considerations;
 - ii) limiting cobalt content of components in contact with coolant;
 - iii) specifying low cobalt content (0.015 per cent) tubing for the steam generator.
- c) **Iron-55** is formed by the activation of the stable isotope iron-54 found in the reactor steel. Minimising its use is not practicable. Controlling corrosion by choosing appropriate materials and the general measures described below will minimise creation of corrosion products that may be activated.
- d) **Nickel-63** is formed by the activation of the stable isotope nickel-62 found in nickel alloys, in particular the steam generator tubes. Minimising the production of nickel-63 is achieved by the same techniques as for cobalt-60.

242 Westinghouse uses several general techniques that ensure low corrosion rates, which it claims are BAT to minimise the production of activated corrosion products in the AP1000 (BAT Assessment form 9):

- a) good quality assurance and control systems for manufacture and construction;
- b) piping design such as the use of pipe bends instead of elbows and making welds smooth to minimise corrosion and to avoid crud traps;

- c) control of coolant to reduce corrosion. The coolant chemistry is selected to minimise corrosion and coolant routinely analysed to confirm it meets specification and the CVS is used to add chemicals to the coolant such as:
 - i) lithium hydroxide to control pH;
 - ii) hydrazine to scavenge oxygen during start-up;
 - iii) dissolved hydrogen to control radiolysis reactions involving hydrogen, oxygen and nitrogen during power;
- d) purifying coolant by filtration and ion exchange in the CVS;
- e) control of chemical quality of make-up water and chemical additives;
- f) zinc injection (at between 5 to 40 parts per billion) into the primary coolant to (ER s2.6.6):
 - i) produce more stable corrosion films that reduce ongoing corrosion;
 - ii) make corrosion products less likely to deposit reducing crud related issues.

243 We consider that the techniques Westinghouse has considered for minimising the production of activated corrosion products in the AP1000 are comprehensive enough and represent feasible techniques at this stage. However, we recognise that techniques may be developed in the future which may be worth considering.

244 **We conclude that Westinghouse has demonstrated that BAT is used to minimise the production of activation products in the AP1000.**

8.1.6 Radioactive actinides

245 Radioactive actinides are formed in the fuel and can enter the coolant as a result of fuel leaks. They are also formed in any trace surface contamination of the fuel pins by fuel (tramp uranium). They may enter the coolant and may be significant in terms of the impact of disposals as the majority are alpha emitters.

246 Westinghouse has not provided any information on the amount of alpha emitting radioactive actinides it expects the AP1000 to produce. However, it lists the following actinides as having a negligible annual discharge to the sea (ER Table 3.4-6): uranium-234, uranium-235, uranium-238, neptunium-237, plutonium-238, plutonium-239, plutonium-240, plutonium-242, americium-241, americium-243, curium-242 and curium-244.

247 Information has been provided about plutonium-241 which is a beta emitting actinide. The amount of plutonium-241 expected to be produced has not been given, however information has been provided about the average amount of plutonium-241 in aqueous discharges which is predicted to be 0.00008 GBq y⁻¹.

248 We accept that the production of plutonium-241 is an inevitable consequence of uranium fission reactions and cannot be prevented in the fuel. Westinghouse claims that the following techniques used in the AP1000 are BAT to minimise the quantity of plutonium-241 potentially present in the coolant:

- a) improved cladding material and quality control in manufacture has greatly reduced the incidence of fuel pin failures (see also noble gases above);
- b) control of uranium contamination in the manufacture of fuel pins;
- c) minimising plant shutdowns;
- d) ultrasonic fuel cleaning.

249 We consider that the techniques Westinghouse has considered for minimising the production of plutonium-241 in the AP1000 are comprehensive enough and represent feasible and proven techniques.

250 We recognise, however, that minimising plant shutdowns will be a matter for future operators of the AP1000, and we will continue to seek assurances that hand over between Westinghouse and future operators will address this matter.

251 **We conclude that Westinghouse has demonstrated that BAT is used to minimise the production of plutonium-241 in the AP1000, and we accept that other actinides do not contribute significantly to annual discharges to the sea.**

8.2 Processing of radioactive materials in the AP1000

252 This section describes how radioactive materials are processed and handled in the AP1000. We expect the options chosen for a new nuclear power plant to minimise the overall impact of their discharges on people and the environment. (Statutory Guidance (DECC, 2009a) and our REPS (Environment Agency, 2010c) RSMDP7)

253 The majority of radioactive materials that will form waste are initially contained within the reactor coolant. Therefore, the options used to treat coolant are important factors that determine the form of radioactive waste and its ultimate disposal to solid, liquid and gaseous waste routes. The diagram below is used for illustrative purposes.

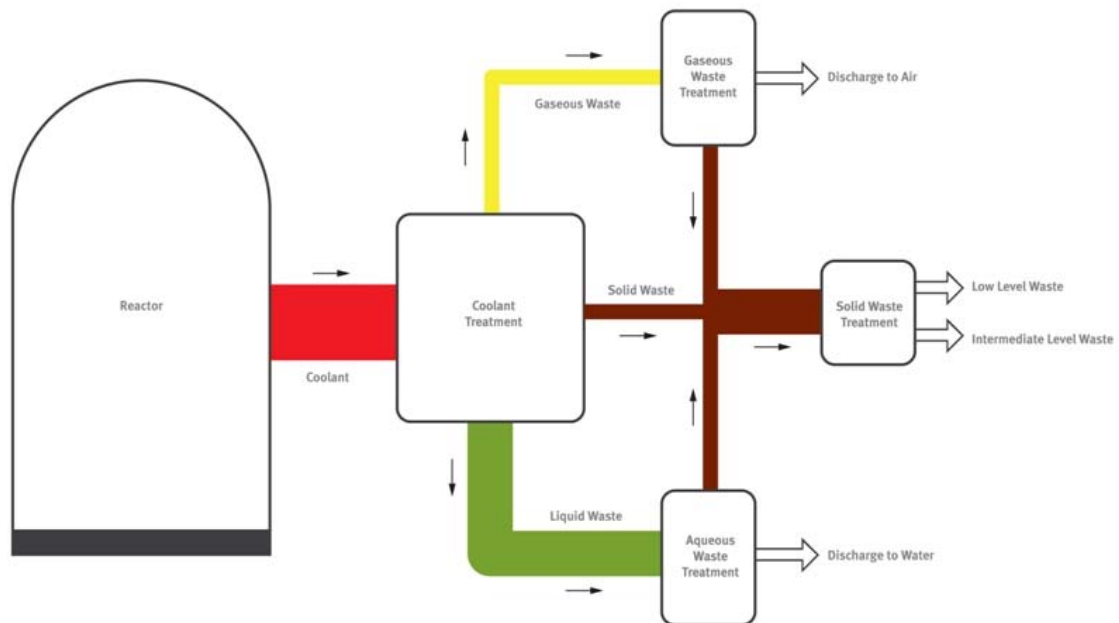

Figure 8-1: Conceptual waste flow diagram for a PWR

254 The reactor coolant system (RCS) includes the reactor, two steam generators, four coolant pumps and a pressuriser. The coolant is essentially water with boric acid added for long-term reactivity control of the reactor and lithium hydroxide to offset the corrosive effect of the acid. The RCS chemistry is controlled by sending a portion of the coolant to the chemical and volume control system (CVS).

255 The CVS (ER s3.2.7) is used to:

- reduce boron concentration by let-down of coolant to the WLS and replacement with demineralised water;
- manage lithium hydroxide to control pH of coolant;
- manage hydrazine at plant start-up to scavenge oxygen;
- manage hydrogen during power operations to eliminate free oxygen. Hydrogen added to control radiolysis product production and limit corrosion of fuel cladding/alloys by reactive species;
- manage zinc acetate to minimise corrosion;
- manage boric acid addition to the RCS.

256 The CVS also purifies the coolant to maintain low system radioactivity. The returning coolant flow is passed through a mixed bed demineraliser to remove dissolved

corrosion products. The mixed bed also acts as a filter to remove particulate corrosion products. The bed is sized to provide demineralisation for one cycle of operation but a second demineraliser is provided in case the operational bed becomes exhausted. A cation bed demineraliser is available to use in the event of fuel leaks and mainly removes caesium isotopes. Filters are installed downstream of the demineralisers for final removal of particulates and resin fines. The filter elements and spent demineraliser resins need to be replaced at intervals and become significant (possibly ILW) solid radioactive waste. We consider using filters and demineralisers in this system in the AP1000 as BAT, with the benefit of reducing the radioactivity of liquid waste outweighing the generation of solid waste. (ER s3.2.10)

257 Iodine radionuclides will also be absorbed in the CVS mixed bed demineraliser. Noble gas removal is not normally necessary when fuel defects are within normally anticipated ranges. If noble gas removal is needed, the CVS can operate together with the WLS degasifier, see below. (ERs3.2.10).

258 **We conclude that detailed arrangements for the handover between Westinghouse and future operators will need to be put in place in relation to using BAT to minimise radioactive discharges. We conclude that this issue will need to be addressed at site-specific permitting (other issue AP1000-OI02).**

8.2.1 The liquid radioactive waste treatment system

259 The liquid radioactive waste treatment system (WLS) is located in the nuclear island auxiliary building. The liquid radioactive waste treatment system allows a number of waste treatment practices.

- a) Degasification - Reactor coolant system effluent entering the reactor coolant drain tank is potentially at high temperature. The design provides for recirculation through a heat exchanger for cooling. The cooled reactor coolant system effluents then pass to vacuum degasifier to remove hydrogen and dissolved radioactive gases before storage in the two effluent hold-up tanks. The stripped gases are vented to the gaseous radioactive waste system. The degasifier column is designed to reduce hydrogen by a factor of 40, assuming inlet flow of $22.7 \text{ m}^3 \text{ h}^{-1}$ at 54°C .
- b) Pre-filtration - The contents of the effluent hold-up tanks and waste hold-up tanks are normally passed through a treatment system comprising an upstream filter followed by four ion exchange resin vessels in series and a downstream filter. A pre-filter is provided to collect particulate matter in the effluent stream before ion exchange. The unit is constructed of stainless steel and uses disposable filter bags. The pre-filter has a nominal particulate removal efficiency of 98 per cent for $25 \mu\text{m}$ particles.
- c) Deep bed filtration - The deep bed filter is a stainless steel vessel containing a layered bed of activated charcoal above a zeolite resin. The activated charcoal provides an adsorption media for removal of trace organics and provides protection for the ion exchange resins from contamination with oil from floor drain waste. The activated charcoal collects particulates and, being less dense than the zeolite, can be removed without disturbing the underlying zeolite bed which minimises solid-waste production. The zeolite resin is clinoptilolite zeolite that is provided for caesium removal. Westinghouse claims that deep bed filtration has a decontamination factor of 1 for iodines, 100 for Cs/Rb and 1 for other radionuclides.
- d) Ion exchange - The design provides three ion exchange beds after the deep bed filter. The ion exchange vessels are vertical, cylindrical pressure vessels made of stainless steel. They have inlet and outlet process nozzles plus connections for resin addition, sluicing, and draining. The process outlet and flush water outlet connections are equipped with resin retention screens designed to minimise

pressure drop. The design flow through the vessels is $17 \text{ m}^3 \text{ h}^{-1}$. Westinghouse claims that this capacity provides an adequate margin for processing a surge in the generation rate of this waste. At the operational stage the ion exchange media will be selected by the plant operator to optimise system performance according to prevailing plant conditions. Typical the resin beds will use the following resins:

- i) the first bed will contain a cation exchange resin and Westinghouse claims that this resin will have a decontamination factor of 1 for iodine, 10 for Cs/Rb and 10 for other radionuclides,
- ii) the second bed will contain a mixed bed resin and Westinghouse claim a decontamination factor of 100 for iodine, 2 for Cs/Rb and 100 for other radionuclides.
- iii) the third bed will contain a mixed bed resin and Westinghouse claim a decontamination factor of 10 for iodine, 10 for Cs/Rb and 10 for other radionuclides.

The ion exchange vessels can be manually bypassed and the order of the last two can be interchanged to ensure that the ion exchange resin is used completely.

The ion exchange beds operate in the borated saturated mode. This means that the boric acid present in the reactor coolant effluent is not removed by the ion exchange beds.

- e) After filter - This filter is provided downstream of the ion exchangers to collect particulate matter, such as resin fines. The unit is constructed of stainless steel and uses disposable filter cartridges. The design filtration efficiency is 98 per cent removal of $0.5 \mu\text{m}$ particles.

260 The liquid radioactive waste system is designed to be flexible and capable of handling a relatively wide range of inputs, including both high grade water (from reactor effluents) and low grade water (floor drains). The flexible design is claimed to allow the operator to make an evaluation to determine the optimum processing technique.

261 To help this evaluation, each collection tank (effluent hold-up tank, waste hold-up tank) will typically be mixed and sampled before processing. The sample will be analysed to provide information on the chemistry and radiological content of the tank contents.

262 It is anticipated that all ion exchangers and filters will be in service and routine bypass of the ion exchangers is not anticipated. However, there may be circumstances where it may be acceptable. The selection of ion exchange vessels in and out of service is made through alignment of manually operated valves. These valves are opened and closed by an operator and are under administrative control to prevent an inadvertent bypass of demineralisers or sub-optimal treatment of waste.

263 Westinghouse claims that the liquid radioactive waste system is designed to handle most liquid effluents and other anticipated events using installed equipment. However, for infrequent events or producing effluent that is not compatible with the installed equipment, temporary equipment may be brought into the radioactive waste building mobile treatment facility truck bays. Any treatment of liquid waste by mobile or temporary equipment will be controlled and confirmed by plant procedures.

264 Mobile equipment connections are provided to and from various locations in the liquid radioactive waste system to allow mobile equipment to be used alongside or instead of installed equipment. Treated liquids would be returned to the liquid radioactive waste system or removed from the site for disposal elsewhere.

265 **We conclude that the availability of appropriate mobile equipment for waste, which is not compatible with the liquid radioactive waste system has not been demonstrated. We conclude that this issue will need to be demonstrated at site-specific permitting (other issue AP1000-OI03).**

8.2.2 The gaseous radioactive waste system

266 The radioactive fission gases entering the gaseous radioactive waste system successively pass through:

- a) the gas cooler, where they are cooled to about 4 °C by the chilled water system;
- b) the moisture separator, which is a 0.01 m³ stainless steel receiver, collects condensed water vapour (including condensed tritiated water vapour) from the cooled gas, removing it from the gaseous radioactivity stream. The moisture separator design pressure is 150 psig and the design temperature is 93 °C. The collected water is periodically discharged automatically to the liquid radioactive waste system;
- c) an activated carbon-filled guard bed, which protects the delay beds from abnormal moisture carryover or chemical contaminants. It absorbs radioactive iodine with efficiencies of 99 per cent for methyl iodine and 99.9 per cent for elemental iodine. It also provides increased delay time for xenon and krypton and deep bed filtration of particulates entrained in the gas stream. The guard bed is made of stainless steel with a volume of 0.277 m³ and a design pressure of 100 psig and a design temperature of 66 °C;
- d) two activated carbon-filled delay beds in series where xenon and krypton are delayed by a dynamic adsorption process. Radioactive decay of the fission gases during the delay period significantly reduces the radioactivity of the gas flow leaving the system. The delay beds are made of carbon steel with a volume of 2.265 m³ and a design pressure of 100 psig and a design temperature of 66 °C.
 - i) The minimum calculated holdup times are 38.6 days for xenon and 2.2 days for krypton, which are based upon a continuous input flowrate to the gaseous radioactive waste system of 0.85 m³ h⁻¹. However, the design basis period of operation is the last 45 days of a fuel cycle when the reactor coolant system dilution and subsequent letdown is greatest. The average input flowrate is 0.024 m³ h⁻¹ which results in longer hold up times being achieved.
 - ii) Each delay bed is designed to provide 100 percent of the required system capacity under design basis conditions. During normal operation a single bed provides adequate performance. This provides operational flexibility to permit continued operation of the gaseous radioactive waste system in the event of operational upset in the system that requires isolation of one bed;
- e) a radiation monitor before discharge to the ventilation exhaust duct.

8.2.3 Ventilation systems

267 We require BAT to be used in the design of ventilation systems. Systems should include appropriate treatment systems to remove and collect airborne radioactive substances before they are discharged to the air. (Our REPS ENDP16)

268 The containment air filtration system (VFS) serves the reactor containment building, the fuel handling area and some other controlled areas. Radioactive materials can be present in the ventilation air from trace leaks of coolant or from activation of argon normally present in air to argon-41. The VFS is normally only operated periodically to reduce detected airborne activity or to maintain containment pressure. (ERs3.3.2.2)

269 The VFS comprises two 100 per cent capacity systems, each with an inlet electric heater, a high efficiency particulate air (HEPA) filter bank, a charcoal iodine adsorber, a post-filter and an exhaust fan. Gaseous radiation monitoring equipment is located downstream of the VFS with an alarm to warn of abnormal releases.

270 The containment venting system includes a filtration system which provides the following functions:

- a) intermittent flow of outdoor air to purge the containment atmosphere of airborne radioactivity during normal plant operation, and a continuous flow during hot or cold plant shutdown conditions to provide an acceptable level of airborne radioactivity before people enter.
 - b) intermittent venting of air into and out of the containment to maintain the containment pressure within its design pressure range during normal plant operation.
 - c) directs the exhaust air from the containment atmosphere to the plant vent for monitoring, and provides filtration to limit the release of airborne radioactivity at the site boundary within acceptable levels.
 - d) monitoring of gaseous, particulate and iodine concentration levels discharged to the environment through the plant vent.
- 271 The two exhaust air filtration units are located within the radiologically controlled area of the annex building. Each exhaust air filtration unit can handle 100 per cent of the system capacity. Each unit consists of an electric heater, an upstream high efficiency particulate air (HEPA) filter bank, a charcoal adsorber with a downstream postfilter bank, and an exhaust fan.
- 272 A radiation monitor is located downstream of the exhaust air filtration units in the common ductwork to provide an alarm if abnormal gaseous releases are detected.
- 273 During normal plant operation, the containment air filtration system is operated from time to time to purge the containment atmosphere as determined by the main control room operator to reduce airborne radioactivity or to maintain the containment pressure within its normal operating range.
- 274 The filtered exhaust air from the containment is discharged to the atmosphere through the plant vent by the exhaust fan. Radioactivity indication and alarms are provided to inform the main control room operators of the concentration of gaseous radioactivity in the containment air filtration system exhaust duct and gaseous, particulate and iodine concentrations in the plant vent.
- 275 Westinghouse provides a specification for its choice of HEPA filter elements in the ER Table 3.3-2. It claims these HEPA filters are BAT as they balance increased pressure drop (with increased energy use) and larger filter volume requiring disposal as LLW against performance. We accept this claim at present but will require performance data to confirm this at site-specific permitting. (ERs3.3.9.2)
- 276 The filtered exhaust air from the VFS is discharged to air through the main plant vent. The vent is monitored for radioactive discharges.
- 277 The radiologically controlled area ventilation system (VAS) serves other areas of the AP1000. In normal circumstances radioactivity is not expected to be collected by the VAS and it discharges without treatment into the main plant vent. (ERs3.3.3)
- 278 There are radiation monitors on the VAS and, if radioactivity is detected, the discharge is diverted into the VFS for treatment. Westinghouse claims this is BAT as the filters and charcoal adsorbers in the VFS are not used unnecessarily, minimising the amount of solid waste produced, as these have to be changed less often. This is an issue we have raised jointly with HSE, and we have requested additional information from Westinghouse on ventilation systems where there is the potential for the release of radioactive wastes to the atmosphere, which do not have passive HEPA filtration as part of the design. We will consider any additional information and use this to inform our decision document.
- 279 **We conclude that the use of BAT to minimise gaseous radioactive waste discharges from the radiologically controlled area ventilation system has not been demonstrated. We will apply a potential GDA Issue to the radiologically controlled area ventilation system and any other ventilations systems where there is the potential for the release of radioactive wastes to the atmosphere**

which do not have passive HEPA filtration as part of the design (GDA Issue AP1000-12).

- 280 The turbine building ventilation system (VTS) comprises roof exhaust ventilators which help to control the temperature of the building. The turbine building air is not normally contaminated with radioactivity and is exhausted without treatment directly to the air via the turbine building stack. The only potential for contamination of the turbine building air arises if there is a steam generator tube leak, which allows radioactivity from the primary circuit to enter the secondary circuit. In this event, operators will take action to deal with this. (ERs3.3.5)
- 281 Extract air from building equipment in the radwaste building is directed to the main plant vent after passing through HEPA filters. (ERs3.3.6)
- 282 The ventilation air from the ILW store passes through two HEPA filters in series before being discharged through a separate ILW store ventilation stack. (ER3.3.7)
- 283 Air in-leakage and non-condensable gases removed from the condenser after the turbine in the secondary circuit do not normally contain radioactivity and are discharged without treatment through the condenser air removal system to the turbine building vent. In the event of a steam generator tube leak, the secondary circuit could become contaminated with radioactivity, in particular with tritium. Radiation monitors are installed to detect contamination so that operators can take the necessary action. (ER s3.3.4)

8.3 Containment of radioactive liquids in the AP1000

- 284 Radioactive liquids will be produced in the AP1000, we expect these liquids to be contained within the facility to prevent contamination of land or groundwater under normal conditions. Under fault conditions we expect BAT to be used to minimise the probability of contamination occurring and the extent of contamination. (Our REPS (Environment Agency 2010c), RSMDP10 and CLDP1)
- 285 Under the Environmental Permitting Regulations 2010 (EPR 10), a permit is required for the deliberate discharge of certain substances, including radioactive substances, to groundwater, to avoid polluting groundwater.
- 286 Westinghouse claims that there is no likelihood of direct or indirect discharges of radioactive substances to groundwater. In that case, an AP1000 should not need to be permitted by us for a discharge to groundwater under EPR 10.
- 287 Westinghouse claims that the AP1000 has 'emphasised best practices with respect to prevention of contamination of land and groundwater'. Westinghouse describes techniques that should prevent contamination (ERs2.9.5), in particular:
- a) simplicity of design reduces lengths of piping and numbers of components reducing potential for leaks;
 - b) nuclear island is built as a single structure without joints in the concrete and is waterproofed. This prevents leakage from any equipment reaching the environment;
 - c) use of embedded pipes minimised;
 - d) use of coolant pumps without mechanical seals;
 - e) spent fuel pool constructed of ½ inch stainless steel plate joined by full penetration welds. The welds are fitted with leak detection systems. The pool is, as far as possible, within a building so leaks would be contained within the building;
 - f) all tanks containing radioactive liquid are within buildings that act as bunds preventing any leaks reaching the environment.
- 288 In the USA, Regulation 10CFR20.1406 requires applicants for licenses to operate nuclear power plant to show how they minimise contamination of the environment. The US NRC issued Regulatory Guide 4.21 in June 2008 to use when reviewing facilities regarding the spread of contamination. Westinghouse claims that AP1000 fully complies with this guidance and we anticipate the US NRC will publish its review findings in May 2010 to confirm this. We accept this guide as an example of good practice and we will review the NRC findings and take account of these in our decision document.
- 289 Westinghouse states that liquid radioactive waste is collected in five tank systems (ER s3.4.2) and provides design and secondary containment information on these tanks (ER Table 3.4-2):
- a) reactor coolant drain tank, 3.4 m³, within containment shell;
 - b) effluent hold-up tanks, 2 x 106 m³, secondary containment within auxiliary building;
 - c) waste hold-up tanks, 2 x 57 m³, secondary containment within auxiliary building;
 - d) chemical waste tank, 34 m³, secondary containment within auxiliary building;
 - e) monitor tanks, 6 x 57 m³, secondary containment will be provided to UK regulatory requirements during site-specific design.
- 290 Westinghouse states that the site of an AP1000 should have a network of boreholes for sampling groundwater established during construction. A conceptual site model should be developed for each specific site and this will help location of boreholes. The network will remain in place during operation and be used to monitor groundwater quality and detect any contaminants that inadvertently reach the water table. We

expect operators to contact us at the early stages of site-specific designs so that we can advise on the appropriate location and construction of boreholes.

291

We conclude at this stage that the AP1000 uses BAT to contain liquids and prevent contamination of groundwater in normal operation. The techniques used should also minimise contamination under fault conditions. However, this is subject to information relating to secondary containment for the monitor tanks being provided at site-specific permitting (other issue AP1000-OI04).

9 Gaseous radioactive waste disposal and limits

292 We conclude that overall the AP1000 utilises the best available techniques (BAT) to minimise discharges of gaseous radioactive waste:

- a) during routine operations and maintenance;
- b) from anticipated operational events.

293 However, our conclusion is subject to one other issue:

- a) a detailed and robust justification of options for carbon-14 abatement in radioactive waste discharges shall be provided at site-specific permitting (AP1000-OI05).

294 We conclude that the gaseous radioactive discharges from the AP1000 should not exceed those of comparable power stations across the world. We note that at this stage the proposed discharges of carbon-14 in gaseous waste are higher than the range for other European PWRs.

295 We conclude that any operational AP1000 should comply with the limits and levels set out below for the disposal of gaseous radioactive waste to air.

Radionuclides or group of radionuclides	Annual limit (GBq)	Quarterly notification level (GBq)
Tritium	3000	600
Carbon-14	1000	210
Iodine-131	0.3	0.03
Noble gases excluding argon-41	13000	1300
All other radionuclides (excepting tritium, carbon-14, iodine radionuclides and noble gases)	0.03	0.003

296 As part of GDA, we are proposing both annual discharge limits and quarterly notification levels (QNLs). Annual limits will probably be expressed as a 12-month rolling average in any permit we may issue. The general principles and methodology for setting limits are set out in our guidance (Environment Agency, 2005), and are consistent with the Government Discharge Strategy which states “in setting discharge limits, the regulators will have regard to the application of Best Available Techniques (BAT)” (DECC, 2009a).

297 Normally we would use operational experience from a reactor in setting QNLs, but as the AP1000 is not yet operating anywhere in the world we do not have that information. Therefore, we have used Westinghouse’s estimates of monthly discharges to set the QNLs. These will be challenging for a new reactor as we wish to assure ourselves that BAT is being used to minimise discharges in accordance with Government expectations (BERR, 2008a). It is possible that with early operational feedback from reactors now under construction that we may need to review and revise the QNLs at the site permitting stage.

Consultation Question 4: Do you have any views or comments on our preliminary conclusions on:

- a. best available techniques to minimise the gaseous discharge of radioactive waste;**
- b. our proposed annual disposal limits;**
- c. our proposed quarterly notification levels?**

298 In addition to using BAT to prevent and, where that is not practicable, minimise the creation of radioactive waste (as discussed above), we also expect new nuclear power plant to use BAT to minimise the radioactivity of discharges of gaseous radioactive waste and to minimise the impact of those discharges on the environment.

299 The sources of gaseous discharges are the reactor coolant system, ventilation systems for the containment building, auxiliary building, turbine building, radwaste building and ILW store and the secondary circuit condenser air removal system.

300 The release points for gaseous radioactive discharges in normal operation are (ER s3.3.8) the main plant vent which is 55.7 m high (ER table 3.3-3) and located on the side of the reactor containment building and the ILW store ventilation stack for which design details are not yet available.

301 Radioactivity could be released under abnormal circumstances from the condenser air removal system and the turbine building ventilation system. These releases would be combined and discharged from the turbine building vent which is 38.4 m high (ER table 3.3-4) and located on the turbine building.

302 Westinghouse provides data on the annual amount of radioactivity in gaseous discharges based, which they have calculated using the revised GALE Code (NUREG-0017, US NRC) and modified by proprietary calculations. (ER Tables 3.3-5 to 3.3-7). Westinghouse also proposes disposal limits (ER s6.1 and Table 6.1-7). We have summarised the information in the table below and included information on our proposed limits and QNLs which are explained further below.

Table 9.1: AP1000 gaseous discharges and proposed limits

	Westinghouse estimate of representative 12-month plant discharge in months 7 to 18 of the cycle (GBq y ⁻¹)	Westinghouse estimate of worst-case plant discharge (WCPD) (GBq y ⁻¹)	Annual limit proposed by Environment Agency (GBq y ⁻¹)	Quarterly notification level proposed by Environment Agency (GBq in any 3 calendar months)
Tritium	1,867	3,081	3,000	600
Carbon-14	638	1,053	1,000	210
Argon-41	1,323	2,182	BAT condition applies	
Cobalt-60	0.00322	0.0053	Included in 'other particulate' limit	
Krypton-85	4,070	6,716	Included in noble gas limit	
Strontium-90	0.000444	0.000733	Included in 'other particulate' limit	
Iodine-131	0.207	0.0342	0.3	0.03
Xenon-133	1,335	2,203	Included in noble gas limit	
Caesium-137	0.00133	0.0022	Included in 'other particulate' limit	
Radioiodines	0.595	0.98	Limit on iodine-131	
Noble gases	8,099	13,363	13,000	1,300
Other particulates ⁽¹⁾	0.0122	0.0201	0.03	0.003

(1) Other particulates are particulate radionuclides not individually listed which are present at very low individual activity levels.

303 Westinghouse considered the requirements of the EU Commission Recommendation 2004/2/Euratom to justify the basis for reporting gaseous radioactive waste discharges.

304 Our Radioactive Substances Regulation Environmental Principle RSMDP8 deals with the segregation of wastes and requires that best available techniques should be used to prevent mixing radioactive substances with other materials, including other radioactive substances, where mixing might compromise subsequent effective management or increase environmental impacts or risks.

305 We consider that the AP1000 design provides for segregating waste so that subsequent management is not compromised.

306 **We conclude that:**

- a) **all sources of gaseous radioactive waste have been identified;**
- b) **the nature and form of gaseous radioactive waste has been identified in enough detail to demonstrate that treatment processes and disposal routes can be envisaged for all gaseous radioactive waste;**
- c) **the data provided by Westinghouse relating to the sources of gaseous radioactive waste is comprehensive, justified and reasonable at the GDA stage.**

9.1 Tritium

307 Tritium is present in the coolant usually replacing one or more hydrogen atoms in water (tritiated water) or less prevalent as a dissolved gas. The majority of tritium will remain in liquid effluent after letdown of coolant to the CVS (some $800 \text{ m}^3 \text{ y}^{-1}$). Gaseous tritium collected in the CVS is sent to the gaseous radwaste system (WGS) and will be discharged to air through the main vent.

308 Westinghouse considers the abatement options to minimise the gaseous discharge of tritium to be (BAT assessment form 1):

- a) decay by delay. Westinghouse considers this option to be impractical as the half-life of tritium is 12.3 years;
- b) adsorption processes. Westinghouse considers that adsorption cannot be used to separate tritiated and non-tritiated gas;
- c) isotopic concentration may be possible but the technology is not well developed and costs of development would be significant and difficult to justify against the impact of unabated discharges;
- d) the use of a condenser will not affect discharge of gaseous tritium but may reduce the discharge of tritiated water vapour. The WGS has a condenser to dry gaseous effluent before it enters the delay beds. This has the benefit of reducing tritium discharge to air by minimising the level of tritiated water vapour in the gaseous effluent. The condensate is directed to liquid effluent;
- e) cryogenic systems could be used to liquefy tritium but will be expensive and difficult to justify against impact of unabated discharges. In addition they are complex and could give higher occupational radiation exposure, produce increased amounts of waste for disposal during operation and at decommissioning and require long-term storage of the separated tritium which may difficult to contain;
- f) optimising plant design, plant availability and operating practices all contribute to minimising tritium production.

309 Westinghouse claims the AP1000 has an improved design and capability to minimise tritium production. Westinghouse claims that no abatement techniques for minimising gaseous tritium discharges are BAT for use on the AP1000. The use of a condenser in the WGS minimises potential for tritiated water discharge to air.

310 Westinghouse provides little detail on some of the techniques for abatement of tritium in gaseous radioactive waste. We consider the optioneering study does not contain enough detail to identify the best option, but we recognise that the impact of tritium discharges without abatement is low. We will provisionally accept that the AP1000 design is BAT for minimising gaseous discharge of tritium. We recognise, however, that operational techniques to minimise tritium discharges will be a matter for future operators of the AP1000, and we will continue to seek assurances that hand over between Westinghouse and future operators will address this matter.

311 Westinghouse predicts that the annual average discharge of tritium over the 18 month cycle from the AP1000 to atmosphere will be 1,800 GBq. (ER Table 3.3-6)

- 312 Westinghouse proposes a discharge limit for tritium from the AP1000. It has predicted monthly discharges over an 18-month cycle and used data from the 12 months in which the discharges are highest (month 7 – 18) to calculate the representative 12-month plant discharge to be 1867 GBq. Westinghouse has applied our limit setting methodology (Environment Agency 2005) to calculate the annual worst-case plant discharge (WCPD), which it has rounded to give its proposed limit. (ERs6.1.3)
- 313 Westinghouse has proposed an annual limit of 3,000 GBq for tritium discharges. (ER Figure 6.1-3 and ER Table 6.1-7)
- 314 We examined historic discharges (where available) from European and US PWRs operating over the last 10 to 15 years and consider that the range of discharges to atmosphere of tritium is 100 to 3600 GBq per annum for a 1000 MWe power station (see Annex 3). We conclude that the gaseous discharge of tritium from UK AP1000 at the predicted annual discharge of 1,800 GBq is comparable to other power stations across the world.
- 315 Westinghouse estimates that the radiological impact from the representative 12-month plant discharge of tritium to atmosphere will result in a dose to the local resident family selected to represent exposure pathways associated with atmospheric releases from the AP1000 of $0.19 \mu\text{Svy}^{-1}$. (ER table 5.2-2). The local resident family comprises infants, children and adults who live 100m from the aerial discharge point. They spend most of their time at home, some of which is spent outdoors. They eat food from local sources and milk from local farms which are 500m from the aerial discharge point. They eat locally caught fish and shellfish.
- 316 We have independently calculated limits for tritium discharges that we may grant and based on the information provided by Westinghouse for GDA, our proposed disposal limit for tritium by discharge to atmosphere is 3,000 GBq in any rolling 12 calendar months. The annual limit for tritium in gaseous discharges from Sizewell B is 3,000 GBq.
- 317 Based on the information Westinghouse has provided for GDA on the discharges of tritium in the three months where they are expected to be the highest, our proposed quarterly notification level for tritium is 600 GBq.

9.2 Carbon-14

- 318 The main source of carbon-14 is the activation of oxygen and nitrogen in the reactor coolant. The carbon-14 is mainly present as carbon atoms in dissolved hydrocarbon gases (75-95 per cent), mainly methane (CH_4) and a small fraction as carbon dioxide (CO_2). A portion of the coolant continually passes through the CVS where dissolved gases are removed and directed to the WGS. The WGS does not remove carbon-14 from the gaseous waste steam and it is discharged through the main plant vent. A small portion of carbon-14 will remain in liquid effluent from the CVS, some of which will become solid waste such as filter elements and spent ion exchange resins.
- 319 Westinghouse provides a review of available gaseous abatement techniques to minimise carbon-14 discharges. Most of the techniques relate to removing CO_2 from gas streams. As most of the carbon-14 is in the form of hydrocarbons a pre-treatment (for example, high temperature catalytic oxidation) is needed to convert the hydrocarbons to CO_2 . This would make any option more expensive and complicated. The options reviewed were: (BAT assessment form 2)
- alkaline slurry scrubber;
 - alkaline packed bed column;
 - double alkali process;
 - gas absorption by wet scrubbing;
 - ethanolamine scrubbing;

- f) absorption in a fluorocarbon solvent;
 - g) physical absorption on an active surface;
 - h) reaction with magnesium;
 - i) isotopic concentration and/or separation;
 - j) cryogenic systems to give liquid CO₂.
- 320 Westinghouse indicates that there are issues for all the above options such as high cost because no system is a proven technique for PWRs and they would need developing. In addition, systems would become more complex and there would be increased occupational radiation exposure. There may also be disposal issues relating to the carbon-14 containing waste generated and additional equipment, which would need to be decommissioned at the end of life.
- 321 Westinghouse claims that no option considered is BAT for use on the AP1000 and proposes direct discharge of carbon-14 without abatement. It recognises, however, that ion exchange systems provided to remove other radionuclides may remove carbon-14 that is present in the form of carbonate and bicarbonate in the coolant. This may reduce the amount of carbon-14 becoming gaseous radioactive waste.
- 322 We consider that the techniques Westinghouse has considered for abatement of carbon-14 in gaseous radioactive waste from the AP1000 are comprehensive enough and represent feasible techniques at this stage. However, we recognise that techniques may be developed in the future which may be worth considering.
- 323 **We provisionally conclude that the AP1000 design is BAT for minimising the gaseous discharge of carbon-14. While the impact from discharges is low, carbon-14 is a significant contributor to doses from gaseous discharges and this conclusion is subject to a detailed and robust justification of options for carbon-14 abatement in radioactive waste discharges being provided at site-specific permitting (other issue AP1000-OI05).**
- 324 Westinghouse predicts that the annual average discharge of carbon-14 over the 18-month cycle from the AP1000 to atmosphere will be 606 GBq. ER Table 3.3-6.
- 325 Westinghouse proposes a discharge limit for carbon-14 from the AP1000. It has predicted monthly discharges over an 18-month cycle and used data from the 12 months in which the discharges are highest (month 7 – 18) to calculate the representative 12-month plant discharge to be 638 GBq. Westinghouse has applied our limit setting methodology (Environment Agency 2005) to calculate the annual worst-case plant discharge (WCPD), which it has rounded to give its proposed limit. (ERs6.1.3)
- 326 Westinghouse proposes an annual limit of 1,000 GBq for carbon-14 discharges. (ER Figure 6.1-3 and ER Table 6.1-7)
- 327 We examined historic discharges (where available) from European PWRs operating over the last 10 to 15 years (see Annex 3) and we consider that the range of discharges to atmosphere of carbon-14 is 40 to 530 GBq per annum for a 1000 MWe power station (see Annex 3). The predicted annual gaseous discharge of carbon-14 from UK AP1000 normalised for power slightly exceeds this range.
- 328 Westinghouse estimates that the radiological impact from the representative 12-month plant discharge of carbon-14 to atmosphere will result in a dose to the local resident family of 7.0 $\mu\text{Sv y}^{-1}$. (ER table 5.2-2)
- 329 We have independently calculated limits for carbon-14 discharges that we may grant and, based on the information Westinghouse has provided for GDA, our proposed disposal limit for carbon-14 by discharge to atmosphere is 1,000 GBq in any 12 rolling calendar months. The annual limit for carbon-14 in gaseous discharges from Sizewell B is 500 GBq.

330 Based on the information Westinghouse provided for GDA, our proposed quarterly notification level for carbon-14 is 210 GBq.

9.3 Noble gases

331 Removing xenon and krypton radionuclides from the coolant is not normally necessary provided fuel defects are within normally anticipated ranges. However, degassing of the coolant is carried out from time to time, in particular during dilutions of the boron content of the coolant, borations and before shutdowns using the vacuum degasifier within the liquid radwaste system (WLS). (ERs3.3.1.1)

332 Gases from degassing enter the gaseous radwaste system (WGS). The WGS is expected to be operated around 70 hours a year. (ERs3.3.1.2)

333 Argon-41 arising from the activation of naturally occurring argon-40 in the air around the reactor is sent to the main stack by the ventilation systems. It does not pass through the GWPS but is monitored in the stack before discharge.

334 Noble gases are inert and, therefore, difficult to remove from gaseous effluent. Westinghouse has provided information on the abatement options for noble gases in the AP1000 (BAT assessment form 8):

- a) Carbon delay beds with a 38.6 day delay for xenon and a 2.2 day delay for krypton.
- b) Minimise plant shutdowns.
- c) Cryogenics to liquefy and separate noble gases.

335 Westinghouse considers that cryogenics would be expensive in capital and running costs, be complex, increase occupational radiation dose and produce waste that is difficult to dispose of. Westinghouse does not consider cryogenic systems BAT for the AP1000, but chooses to rely on carbon beds in the WGS to delay the discharge of noble gases and, therefore, reduce discharged radioactivity through radioactive decay.

336 The WGS is a once-through, ambient temperature, activated carbon delay system comprising (ERs3.3.1.2):

- a) a chilled water gas cooler;
- b) a moisture separator – the condensed water is discharged to the WLS;
- c) an activated carbon guard bed protecting the delay beds from excess moisture and absorbing more than 90 per cent of iodines. It also acts as deep bed filtration for any particulates entrained in the gas stream;
- d) two activated carbon beds in series providing a 38.6 day delay for xenon and a 2.2 day delay for krypton. Xenons, with a maximum half-life of 5.25 days should be decayed to less than 0.5 per cent of the activity entering the WGS. Krypton-85m, krypton-87 and krypton-88 with half-lives of only a few hours will be substantially reduced, but krypton-85 with a half-life of 10.72 years will be unaffected. The beds are designed so that a single bed can provide adequate performance if one bed is unavailable.

337 Westinghouse provides a BAT assessment to justify the sizing of the delay bed (ERs3.3.9.1). The beds have a folded serpentine design so that each has four adsorption legs where the length to diameter ratio maximises delay time. The two beds are in series and each has four adsorption legs. Westinghouse claims that (ER Figure 3.3-3) increasing the total number of legs beyond eight has a limited effect in reducing activity. Westinghouse concludes that providing two beds in series is BAT.

338 **We conclude that the techniques considered by Westinghouse for the abatement of xenon and krypton radionuclides in gaseous radioactive waste from the AP1000 are BAT.**

339 Westinghouse has predicted the annual average discharge of noble gases over the 18-month cycle from the AP1000 to atmosphere set out in the table below, ER Table 3.3-6:

Radionuclide	Activity in gaseous discharge (GBq y ⁻¹)
Argon-41	1,300
Krypton radionuclides	3,170
Xenon radionuclides	3,577
Total	8,047

340 Westinghouse proposes a discharge limit for noble gases (excluding argon-41) from the AP1000. It has predicted monthly discharges over an 18-month cycle and used data from the 12 months in which the discharges are highest (month 7 – 18) to calculate the representative 12-month plant discharge to be 8099 GBq. Westinghouse has applied our limit setting methodology (Environment Agency 2005) to calculate the annual worst-case plant discharge (WCPD), which it has rounded to give its proposed limit. (ERs6.1.3)

341 Westinghouse proposes an annual limit of 13,000 GBq for noble gases (excluding argon-41) based on a 0.25 per cent failed fuel rate. (ER Figure 6.1-2 and ER Table 6.1-7).

342 We examined historic discharges (where available) from European and US PWRs operating over the last 10 to 15 years and we consider that the range of discharges to atmosphere of noble gases is 100 to 10,000 GBq per annum for a 1000 MWe power station. The predicted annual gaseous discharge of noble gases from AP1000 at 8047 GBq is within this range. We conclude that gaseous discharge of noble gases is comparable to other power stations across the world.

343 Westinghouse estimates that the radiological impact from the representative 12-month plant discharge disposal to atmosphere will result in doses to the local resident family set out below: (ER table 5.2-2)

- a) estimated dose from argon-41 is 0.13 $\mu\text{Sv y}^{-1}$
- b) estimated dose from krypton-85 is 0.0016 $\mu\text{Sv y}^{-1}$
- c) estimated dose from xenon-133 is 0.0028 $\mu\text{Sv y}^{-1}$

344 We have independently calculated limits on noble gas discharges that we may grant and based on the information Westinghouse provided for GDA, our proposed disposal limit for the disposal of noble gases (excluding argon-41) by discharge to the atmosphere is 13,000 GB in any rolling 12 calendar months. The annual limit for noble gases in gaseous discharges from Sizewell B is 30,000 GBq.

345 The annual average discharge includes an allowance for failed fuel pins. Westinghouse has not provided an estimate of discharge without pin failures and we normally base our QNL on this level. Our assessment of data suggests that noble gas discharges are often low or at detection levels with no failed pins but increase rapidly with pin failures. To give us early indication of pin failures, we will set the QNL at 1,300 GBq, which is 10 per cent of the disposal limit.

9.4 Iodine radionuclides

346 Iodine radionuclides are formed by fission in the fuel and can escape into the coolant through cladding defects. Escape through defects can be accentuated by changes in reactor condition such as power output, in particular at shut-down.

- 347 As is the case for noble gases, gaseous effluent containing iodine radionuclides is sent to the WGS from the degasifier. Westinghouse claims that iodine radionuclides will be delayed by the carbon delay beds in the WGS, however they do not provide an estimate of reduction in discharges as a result of delay.
- 348 Iodine radionuclides can also enter the containment atmosphere through leaks of coolant. In such an event Westinghouse claims that most of the iodine radionuclides are deposited on surfaces in the containment area by natural processes. Whenever the containment is ventilated the exhaust air is passed through HEPA filters and impregnated charcoal filters.
- 349 Westinghouse provides a review of available gaseous abatement techniques to minimise discharge of iodine radionuclides (BAT assessment form 5). These include using:
- a) silver reactor technology using solid absorber coated with silver nitrate which retains iodine radionuclides and allows them to decay;
 - b) mercurex process which is a liquid scrubbing process using mercuric nitrate/nitric acid solution;
 - c) iodox which is a liquid scrubbing process using hyperazeotropic nitric acid;
 - d) electrolytic scrubbing which employs an electrolytically generated chemical oxidant;
 - e) liquid scrubbing with various organic liquids;
 - f) solid absorption by organic resins;
 - g) caustic liquid scrubbing using sodium or potassium hydroxide;
 - h) iodine trapping using silver containing sorbents such as treated zeolites.
- 350 Westinghouse indicates issues with technical development, complexity or cost for all the above techniques. Westinghouse claims that deposition in the containment and using delay beds are BAT for minimising the discharge of iodine radionuclides to atmosphere from the AP1000.
- 351 **We consider that the techniques Westinghouse has considered for the abatement of iodine radionuclides in gaseous radioactive waste from the AP1000 are comprehensive enough and represent a range of feasible proven techniques and techniques at the development stage. We conclude that Westinghouse has demonstrated that BAT is used to minimise discharges of iodine radionuclides from the AP1000.**
- 352 Westinghouse predicts that the annual average discharge of iodine radionuclides over the 18 month cycle from the AP1000 to atmosphere will be: (ER Table 3.3-5)
- a) Iodine-131 = 0.21 GBq
 - b) Iodine-133 = 0.35 GBq
 - c) Total iodine radionuclides = 0.56 GBq.
- 353 Westinghouse proposes a discharge limit for iodine radionuclides from the AP1000. It has predicted monthly discharges over an 18-month cycle and used data from the 12 months in which the discharges are highest (month 7 – 18) to calculate the representative 12-month plant discharge to be 0.595GBq. Westinghouse has applied our limit setting methodology (Environment Agency 2005) to calculate the annual worst-case plant discharge (WCPD), which it has rounded to give its proposed limit. (ERs6.1.3)
- 354 We examined historic discharges (where available) from European and US PWRs operating over the last 10 to 15 years and we consider that the range of discharges to atmosphere of iodine-131 is 10 to 200 MBq per annum for a 1000 MWe power station (see Annex 3). The predicted annual gaseous discharge of iodine-131 normalised for

power is 185 MBq which is within the range. We conclude that gaseous discharge of iodine radionuclides is comparable to other power stations across the world.

355 Westinghouse proposes an annual limit of 1 GBq for discharges of iodine radionuclides assuming a 0.25 per cent failed fuel rate. (ER Figure 6.1-1 and ER Table 6.1-7)

356 Westinghouse estimates that the radiological impact from the representative 12-month plant discharge of iodine radionuclides to atmosphere will result in a dose to the local resident family of $0.27 \mu\text{Sv y}^{-1}$ (ER table 5.2-2).

357 We have independently calculated limits on discharges of iodine radionuclides that we may grant and based on the information provided by Westinghouse for GDA. We consider that a limit on iodine-131 is appropriate and our proposed disposal limit for iodine-131 by discharge to the atmosphere is 0.3 GBq in any 12 rolling calendar months. The annual limit for iodine-131 in gaseous discharges from Sizewell B is 0.5 GBq.

358 The annual average discharge includes allowance for a failed fuel pin fraction. Westinghouse has not provided an estimate of discharge without pin failures and we normally base our QNL on this level. Our assessment of data suggests that gaseous radioiodine discharges are often low or at detection levels with no failed pins but increase rapidly with pin failures. To give us early indication of fuel failures, we will set the QNL for iodine-131 at 0.03 GBq, which is 10 per cent of the disposal limit.

9.5 Other radionuclides

359 Activated corrosion products are present in the reactor coolant and may be found in aerosols (a dispersion of solid or liquid particles in a gas) produced from:

- a) equipment leaks into the containment area. Coolant from these leaks can dry out and the radioactive dust can be re-suspended in air and enter the ventilation systems.
- b) treatment of the coolant in the degasifier in the WLS, the gas phase is sent to the WGS.

360 Activated corrosion products can be present as particulate in the final discharge to air. The most significant are particulates containing the radionuclides cobalt-58 and cobalt-60.

361 Fission products may be present in the coolant in the event of fuel cladding failures. The main particulate fission of concern that may be present in gaseous waste discharged to atmosphere is caesium-137.

362 The AP1000 relies on the purification loop in the CVS to control the level of particulates in the coolant and, therefore, minimise radioactivity reaching the WLS or present in leaks. The loop contains mixed bed demineralisers to remove dissolved corrosion products and filters to remove suspended particulate corrosion products.

363 Westinghouse provides a review of abatement techniques to minimise particulates in gaseous discharges (BAT assessment form 9):

- a) wet scrubbing;
- b) direct discharge;
- c) using carbon delay beds in the WGS to provide an effective deep bed filter for removing particulates. Westinghouse claims that HEPA filters are not considered necessary after these beds;
- d) using HEPA filters to detect radioactivity in the radiologically controlled area ventilation systems of the AP1000.

364 **We conclude that the techniques Westinghouse has considered for the abatement of beta emitting particulates in gaseous radioactive waste from the AP1000 are comprehensive enough and represent feasible techniques at this stage.**

365 Westinghouse claims that using carbon delay beds and HEPA filtration in the gaseous radwaste system and the containment air filtration system is BAT for particulates in the gaseous waste stream.

366 Westinghouse claims that delay beds and HEPA filtration for radiologically controlled areas is included in the AP1000 design. However, it does not consider HEPA filtration of gaseous waste from radiologically controlled areas is necessary unless the waste is found to contain radioactivity. In this event, it will be treated using carbon delay beds and filter in the VFS.

367 We consider the use of carbon delay beds and HEPA filtration in the gaseous radwaste system and the containment air filtration system is BAT for minimising discharges of beta emitting particulates in gaseous radioactive waste from the AP1000.

368 Westinghouse has predicted that the annual average discharge of radioactive particulates from the AP1000 to atmosphere will be: ER Table 3.3-6

Radionuclide	Expected annual release, GBq
Cobalt-58	0.0085
Cobalt-60	0.0032
Caesium-137	0.0013
Strontium-90	0.00044

369 Westinghouse proposes a discharge limit for radioactive particulates from the AP1000. It has predicted monthly discharges over an 18-month cycle and used data from the 12 months in which the discharges are highest (month 7 – 18) to calculate the representative 12-month plant discharge to be 0.0284 GBq. Westinghouse has applied our limit setting methodology (Environment Agency 2005) to calculate the worst-case annual plant discharge (WCPD), which it has rounded to give its proposed limit. (ERs6.1.3)

370 Westinghouse proposes an annual limit of 0.03 GBq for discharges of radioactive particulates. (ER Figure 6.1-7 and ER Table 6.1-7)

371 We examined historic discharges (where available) from European and US PWRs operating over the last 10 to 15 years and we consider that the range of discharges to atmosphere of fission and activation products is 0.5 to 1000 MBq y⁻¹ for a 1000 MWe power station (see Annex 3). The predicted gaseous discharge of radioactive particulates from AP1000 is within this range. We conclude that gaseous discharge of radioactive particulates is comparable to other power stations across the world.

372 Westinghouse estimates that the radiological impact from the representative 12-month discharge of cobalt-60 to atmosphere will result in a dose to the local resident family of 0.0011 µSv y⁻¹. (ER table 5.2-2).

373 Westinghouse estimates that the radiological impact from representative 12-month discharge of caesium-137 to atmosphere will result in a dose to the local resident family of 0.00041 µSv y⁻¹.

374 Westinghouse estimates that the radiological impact from the representative 12-month discharge of strontium-90 to atmosphere will result in a dose to the local resident family of 0.000096 µSv y⁻¹.

- 375 We have independently calculated limits on radioactive particulates discharges that we may grant and, based on the information Westinghouse has provided for GDA, our proposed limit for the disposal of radioactive particulates by discharge to the atmosphere is 0.03 GBq in any 12 rolling calendar months. The annual limit for beta particulates in gaseous discharges from Sizewell B is 0.1 GBq.
- 376 Based on the information Westinghouse has provided for GDA, our proposed quarterly notification level for total radioactive particulates is 0.003 GBq.

9.6 Gaseous radioactive waste disposal to the environment

377 The only release points for gaseous radioactive discharges in normal operation are (ERs3.3.8):

- a) the main plant vent which is 55.7 m high and located on the side of the reactor containment building;
- b) ILW store ventilation stack for which the design details are not yet available.

378 Radioactivity could be released under abnormal circumstances from:

- a) the condenser air removal system;
- b) the turbine building ventilation system.

379 These releases are combined and discharged from the turbine building vent which is 38.4 m high and located on the turbine building.

10 Aqueous radioactive waste disposal and limits

380 We conclude that overall the AP1000 utilises the best available techniques (BAT) to minimise discharges of aqueous radioactive waste:

- a) during routine operations and maintenance;
- b) from anticipated operational events.

381 However, our conclusion is subject to one other issue:

- a) a detailed and robust justification of options for carbon-14 abatement in radioactive waste discharges shall be provided at site-specific permitting (AP1000-OI05).

382 We conclude that the aqueous radioactive discharges from the AP1000 should not exceed those of comparable power stations across the world.

383 We conclude that the AP1000 should comply with the aqueous limits and levels set out below for the disposal of aqueous radioactive waste to the environment.

Radionuclides or group of radionuclides	Annual limit (GBq)	Quarterly notification level (GBq)
Tritium	60,000	11,000
Carbon-14	7	2.5
Cobalt-60	0.5	0.18
Caesium-137	0.05	0.018
All other radionuclides (excepting tritium, carbon-14, cobalt-60 and caesium137)	5	1.8

Consultation Question 5: Do you have any views or comments on our preliminary conclusions on:

- a. best available techniques to minimise the aqueous discharge of radioactive waste;**
- b. our proposed annual disposal limits;**
- c. our proposed quarterly notification levels?**

384 In addition to using BAT to prevent and, where that is not practicable, minimise the creation of radioactive waste (as discussed above), we also expect new nuclear power plant to use BAT to minimise the radioactivity of discharges of aqueous radioactive waste and to minimise the impact of those discharges on the environment.

385 Westinghouse has provided information on the sources of aqueous radioactive waste (ER s3.4.1) and expected effluent arisings. (ER Table 3.4-1)

386 Reactor coolant system effluents arise from two sources:

- a) leaks and drainage from primary systems collected in the reactor coolant drain tank of 3.4 m³;
- b) letdown from the chemical and volume control system (CVS) usually as a result of coolant system heat up, boron concentration changes or RCS level reduction for refuelling.

- These sources are directed to the degasification system in the WLS.
- 387 **Floor drains** and other waste with potentially high suspended solids contents are routed to one of two waste hold-up tanks. Each of these tanks has a usable volume of 57 m³ and is normally discharged to the filtration and ion exchange system of the WLS.
- 388 **Detergent wastes** from the plant hot sinks and showers and some cleanup processes are routed to the chemical waste tank. The chemical waste tank has a volume of 34 m³. If the radioactivity of this waste is low, the tank contents can be sent to the monitoring tanks for discharge without treatment. If the waste is above an acceptable level for direct discharge, it can be sent to a waste hold-up tank for treatment in the WLS. However, some waste is chemically incompatible with the resins in the WLS and could cause damage. This waste would be treated using mobile treatment plant or by sending the liquids off-site for treatment and disposal. (ER3.4.3.9)
- 389 **Chemical waste** collected from laboratories and other small sources is also routed to the chemical waste tank and treated along with detergent waste. (ER3.4.3.10)
- 390 **Steam generator blowdown** is normally non-radioactive and discharged through a separate blowdown system. If there are steam generator tube leaks, the blowdown could contain radioactivity and, in this event, it is routed to a waste hold-up tank before treatment in the liquid radwaste system (WLS).
- 391 The WLS is designed to control, collect, process, handle, store and dispose of aqueous radioactive waste generated as a result of normal operations of the AP1000. (ERs3.4 and 3.4.3, a schematic of the system is at ER Figure 3.4-1, repeated as Figure 10.1 below).

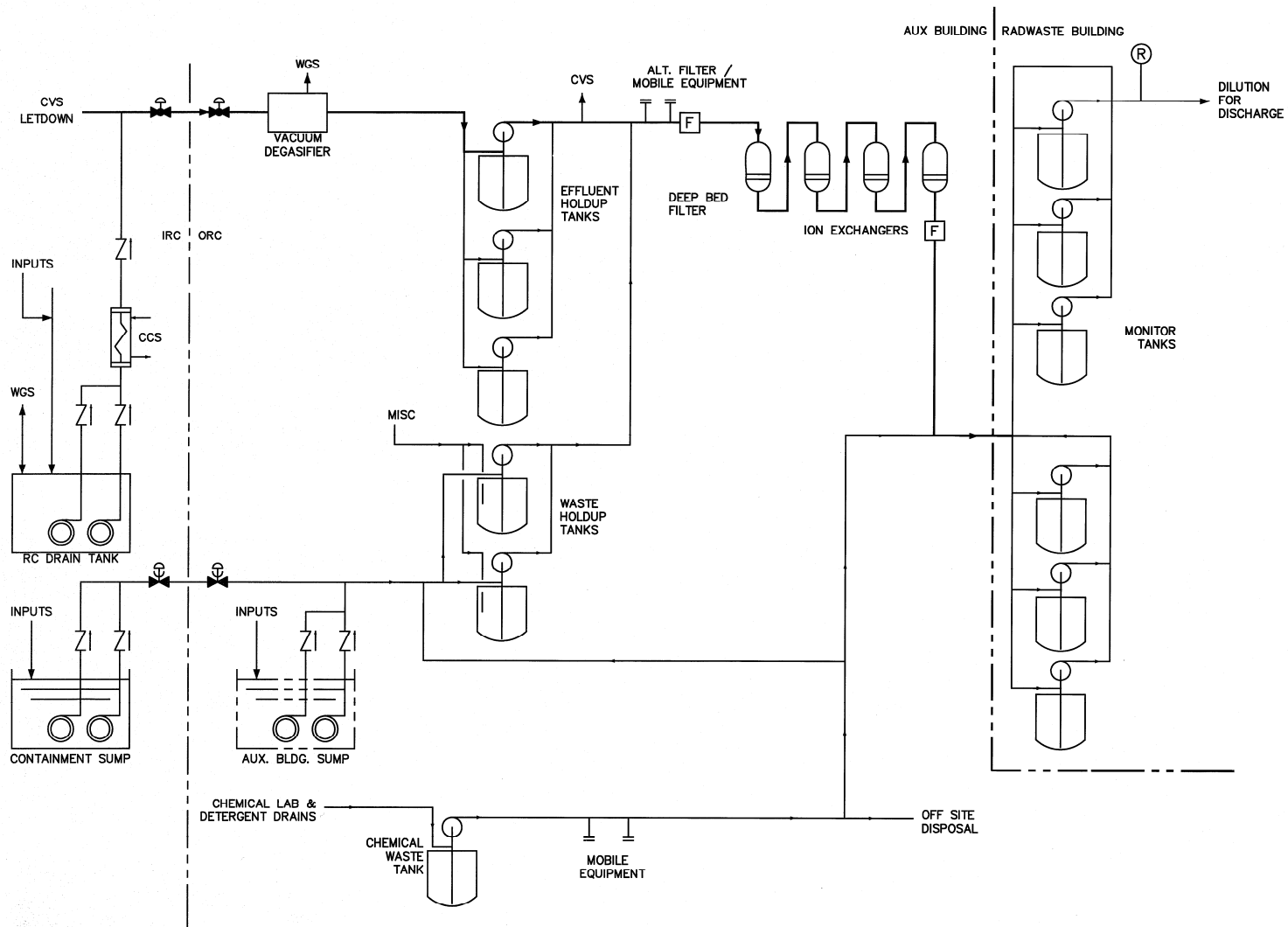

Figure 10.1: AP1000 liquid radwaste system (ER Fig 3.4-1)

392 The WLS has the following equipment:

- a) **Degasifier** – a vacuum degasification system removes hydrogen and dissolved radioactive gases from coolant system effluents and stores the degassed effluent in two effluent hold-up tanks. Gases stripped from the effluents are sent to the WGS. (ERs3.4.3.1). The effluent hold up tanks each have a usable volume of 106 m³. The contents of the effluent hold-up tanks can be:
 - i) returned to the RCS through the CVS;
 - ii) sent to the monitor tanks for discharge;
 - iii) passed through the filtration and ion exchange units of the WLS.
- b) **Pre-filter** – effluents from the effluent hold-up tanks and the waste hold-up tanks are first passed through a filter that is made of stainless steel with disposable filter bags. The filter is claimed to remove 98 per cent of particles with a size greater than 25 µm. (ERs3.3.3.2)
- c) **Deep bed filter** – this is a layered bed of activated carbon above a clinoptilolite zeolite resin. The charcoal adsorbs trace organics and protects downstream resins from oil that could enter floor drains. The zeolite resin is claimed to have a good decontamination factor for caesium. (ERs3.4.3.3)
- d) **Ion exchange system** – this is a three bed system with cation exchange resin in the first bed and mixed resin in the others. Westinghouse provides decontamination factors in ER Table 3.4-4 but notes that ion exchange resins will be selected at the operational stage to optimise performance. (ERs3.4.3.4)
- e) **Filter** – there is a final filter after the ion exchangers to collect particulate such as resin fines. The filter housing is of stainless steel construction with disposable filter cartridges. The filter should remove 98 per cent of particles of size greater than 0.5 µm. (ERs3.4.3.5)

393 The WLS has connections so mobile or temporary equipment can be used if required to cope with unusual circumstances. The radwaste building has truck bays available for such equipment. (ERs3.4.3.8)

394 Westinghouse has provided a BAT case for the WLS that supports using ion exchange and a cartridge filter. Three alternatives are discussed below. (ERs3.4.4)

10.1 Evaporation in place of ion exchange

395 Westinghouse recognises that effluents could be treated by evaporation. (ER Figure 3.4-2). The evaporator bottoms would need to be treated to create a solid waste for disposal. The distillate could be discharged to water after treatment and polishing with demineralisers and filters but would still contain radioactivity. Westinghouse has compared using evaporators against ion exchange in ER Table 3.4-5.

396 Westinghouse claims that reactors located on rivers tend to use evaporators to minimise radioactive liquid discharges as rivers have less capacity for dilution and dispersal of effluents. The GDA case is for discharge of aqueous radioactive waste to sea where dispersal is less of an issue.

397 Westinghouse claims that evaporators tend to be complex and need significant maintenance, with associated occupational radiation exposure of workers. There is also the cost of steam supply to run the evaporators, which diverts steam away from generating electricity.

398 Westinghouse estimates that 102 m³ of evaporator bottoms would need to be disposed of each year. (ER Table 3.4-5) The treatment and disposal of the evaporator bottoms concentrate would have an impact in terms of radiation exposure to workers and costs.

399 Westinghouse claims that using ion exchange and filters offers a simpler and safer option that will still effectively control discharges of radioactivity. Westinghouse believes its impact assessment for the GDA generic site demonstrates that discharges are not excessive. It concludes that the proposed WLS is BAT. (ERs3.4.4.1)

10.2 Boron discharge or boron recycle

400 The AP1000 design does not include boron recycle and any boron present in effluents will be discharged to the sea. Westinghouse claims that the AP1000 design minimises production of aqueous radioactive waste, in particular, using mechanical rather than chemical controls reduces the quantity of boron needed to control reactivity.

401 Westinghouse claims that boron recycling requires a significant amount of additional equipment and because recycling can only occur in the next fuel cycle, borated water would need to be stored for long periods. The operation, maintenance and storage of borated water is likely to increase occupational radiation exposure and Westinghouse does not consider this to be ALARP.

402 In order to protect the marine environment there is an Environmental Quality Standard relating to the concentration of boron in seawater. Westinghouse claims the AP1000 discharge of boron would have a negligible effect on receiving waters, and it concludes that boron discharge is BAT. (ERs3.4.4.3)

10.3 Filtration options

403 The WLS includes a final 0.5 µm disposable cartridge filter to remove particulate material greater than 0.5 µm in size. Westinghouse has considered other filter technologies that potentially could remove smaller particulate material at sizes from 0.1 to 0.001 µm. These include:

- a) microfiltration;
- b) ultrafiltration;
- c) nanofiltration;
- d) reverse osmosis.

404 Westinghouse claims that these techniques have disadvantages that outweigh the benefit of reduced particulates because:

- a) high pressure systems are needed which may increase the risk of leaks;
- b) system designs are more complicated;
- c) membranes used in the system may be subject to degradation by radioactivity;
- d) higher maintenance requirements may lead to potential for higher occupational radiation exposure;
- e) more equipment may be produced which needs to be disposed of as radioactive waste at decommissioning;
- f) higher capital and operating costs.

405 Westinghouse concludes that using cartridge filters is BAT for final liquid filtration in the AP1000. (ERs3.4.4.4)

406 Westinghouse provides data on the annual amount of radioactivity in aqueous discharges that it has calculated using the revised GALE Code (NUREG-0017) and modified by proprietary calculations (ER table 3.4-6). Westinghouse also proposes disposal limits (ER s6.1 and Table 6.1-8). We have summarised the information below in Table 10.1 and included information on our proposed limits and QNLs which are explained further below.

Table 10.1: Aqueous radioactive waste discharges and proposed limits

	Representative 12-month plant discharge in months 7 to 18 of the cycle (GBq y ⁻¹)	Westinghouse estimate of worst-case plant discharge (WCPD) (GBq y ⁻¹)	Annual limit proposed by Environment Agency (GBq y ⁻¹)	Quarterly notification level proposed by Environment Agency (GBq in any 3 calendar months)
Tritium	35,090	57,900	60,000	11,000
Carbon-14	4.42	7.30	7	2.5
Cobalt-60	0.301	0.497	0.5	0.18
Caesium-137	0.03	0.0497	0.05	0.018
Other radionuclides (excepting tritium, carbon-14, cobalt-60 and caesium-137) taken together	2.95	5.35	5	1.8

407 Westinghouse has considered the requirements of the EU Commission Recommendation 2004/2/Euratom to justify the basis for reporting aqueous radioactive waste discharges.

408 Our Radioactive Substances Regulation Environmental Principle RSMDP8 deals with the segregation of waste and requires that best available techniques should be used to prevent mixing radioactive substances with other materials, including other radioactive substances, where mixing might compromise subsequent effective management or increase environmental impacts or risks.

409 We consider that the AP1000 design provides for segregating waste so that subsequent management is not compromised.

410 **We conclude that:**

- a) **all sources of aqueous radioactive waste have been identified;**
- b) **the nature, form and quantity of aqueous radioactive waste has been identified in enough detail to demonstrate that treatment processes and disposal routes can be envisaged for all aqueous radioactive waste;**
- c) **the data Westinghouse has provided relating to the sources of aqueous radioactive waste is comprehensive, justified and reasonable at the GDA stage.**

10.4 Tritium

411 Tritium is present as tritiated water in the reactor coolant. Coolant is processed in the CVS and Westinghouse states that approximately 800 m³ each year will be sent to the WLS for discharge to sea after processing.

412 The filtration and ion exchange systems in the WLS do not effectively remove tritium. Westinghouse reviewed abatement techniques to determine techniques that represent BAT for tritium in aqueous radioactive waste from the AP1000 (BAT Assessment form 1):

- a) adsorption - Westinghouse claims this has no known application for tritium;
 - b) wet scrubbing – Westinghouse claims this is only applicable to particulate in air and not tritiated water;
 - c) evaporation – Westinghouse claims there is no benefit in evaporation as tritiated water behaves as water and no separation is achieved;
 - d) precipitation/filtration – Westinghouse claims this is not applicable for tritiated water;
 - e) ion exchange – Westinghouse claims this is not applicable for tritiated water;
 - f) isotopic concentration/separation – Westinghouse recognises this is a possible technique for abating tritium but the technology is as yet undeveloped and the costs to develop the technology and apply it to the AP1000 would be significant and difficult to justify against the impact of unabated discharges;
 - g) decay by delay – Westinghouse claims this is impractical as the half-life of tritium is 12.3 years.
- 413 Westinghouse claims that, in relation to tritium discharges to sea, direct discharge is BAT. Westinghouse also claims that plant operation can significantly affect the amount of tritium produced and that the AP1000 design that optimises plant availability contributes to minimising tritium production. Management techniques such as operator training which optimise operations are relevant to reducing the production of tritium.
- 414 Westinghouse provides little detail on the techniques for abatement of tritium in aqueous radioactive waste discharges. We consider the optioneering study contains insufficient detail to identify the best option however we recognise that the impact of tritium in liquid discharges without abatement is low therefore we provisionally accept that there are no available techniques to abate discharges of tritium to the sea.
- 415 We recognise, however, that minimising plant shutdowns will be a matter for future operators of the AP1000 and we will continue to seek assurances that the hand over between Westinghouse and future operators will address this matter.
- 416 Westinghouse predicts that the annual average discharge of tritium from the AP1000 to sea will be 33,400 GBq. (ER Table 3.4-6)
- 417 Westinghouse proposes a discharge limit for tritium from the AP1000. It has predicted monthly discharges over an 18-month cycle and used data from the 12 months in which the discharges are highest (month 7 – 18) to calculate the representative 12-month plant discharge to be 35090 GBq. Westinghouse has applied our limit setting methodology (Environment Agency 2005) to calculate the annual worst-case plant discharge (WCPD), which it has rounded to give its proposed limit. (ERs6.1.3)
- 418 Westinghouse proposes an annual limit of 60,000 GBq for tritium in aqueous radioactive waste discharges. (ER Figure 6.1-8 and ER Table 6.1-8).
- 419 We examined historic discharges (where available) from European and US PWRs operating over the last 10 to 15 years and we consider that the range of discharges to water of tritium is 2000 to 30,000 GBq per annum for a 1000 MWe power station. (see Annex 3). The predicted annual average aqueous discharge of tritium from AP1000 normalised for power is slightly above the range, however the impact is low. We conclude that aqueous discharge of tritium is comparable to other power stations across the world.
- 420 Westinghouse estimates that the radiological impact from the representative 12-month plant discharge of tritium to sea will result in a dose to the local fisherman family, selected to represent the exposure pathways associated with discharges from the AP1000 to the coastal environment, of $0.024 \mu\text{Sv y}^{-1}$. (ER table 5.2-1). The fisherman and his family are assumed to spend time on intertidal sediments in the area and consume high levels of locally caught fish and shellfish as well as smaller amounts of

locally produced fruit and vegetables from local sources up to 500m from the aerial discharge point. This group live far enough from the site not to be exposed to direct radiation from atmospheric releases.

421 We have independently calculated limits for tritium discharges that we may grant and based on the information Westinghouse provided for GDA, our proposed disposal limit for tritium by discharge to the sea is 60,000 GBq in any 12 rolling calendar months. The current limit for tritium in aqueous radioactive waste from Sizewell B is 80,000 GBq.

422 Based on the information Westinghouse provided for GDA, our proposed quarterly notification level for tritium is 11,000 GBq.

10.5 Carbon-14

423 Carbon-14 is present in the coolant mainly as dissolved hydrocarbon gases. These gases are mostly removed in the CVS and WLS degasifier and are discharged to the air. Westinghouse claims only a small portion of carbon-14 remains in the liquid effluent, although we note HSE have queried how using zinc acetate may increase the amount of carbon-14 remaining as graphite particles in the liquid. Of the total predicted production of 662 GBq y⁻¹, Westinghouse predicts 53 GBq will be in solid waste, 606 GBq will be discharged to air and 3.3 GBq discharged to the sea. (BAT assessment form 2)

424 Westinghouse claims that the nuclear industry does not currently use any specific techniques to minimise the carbon-14 content of aqueous radioactive waste.

425 Westinghouse has considered the following options for abatement of carbon-14 in aqueous radioactive waste:

- a) ion exchange - The AP1000 design provides ion exchange beds as the primary abatement technique for removing trace dissolved metal radionuclides. These beds will also be effective at removing any carbon-14 in the form of carbonates or bicarbonates, which will result in carbon-14 in certain solid waste, mainly in spent resins.
- b) evaporation – Westinghouse has considered using evaporation but claim this would have little effect as many forms of carbon-14 would remain with the distillate for disposal to the sea.
- c) no abatement – direct discharge of aqueous radioactive waste to the environment.

426 Westinghouse claims, considering the low proportion of carbon-14 remaining in aqueous radioactive waste after the ion exchange beds, that direct discharge is BAT for the AP1000.

427 **We conclude that the techniques Westinghouse has considered for abatement of carbon-14 in aqueous radioactive waste discharges from the AP1000 are comprehensive enough and represent feasible techniques at this stage, but we do recognise that techniques may be developed in the future which may be worth considering. Therefore we expect a detailed and robust justification of options for carbon-14 abatement in radioactive waste discharges to be provided at site-specific permitting (other issue AP1000-OI05).**

428 Westinghouse predicts that the annual average discharge of carbon-14 from the AP1000 to sea will be 3.3 GBq. (ER Table 3.4-6)

429 Westinghouse proposes a discharge limit for carbon-14 from the AP1000. It has predicted monthly discharges over an 18-month cycle and used data from the 12 months in which the discharges are highest (month 7 – 18) to calculate the representative 12-month plant discharge to be 4.42 GBq. Westinghouse has applied our limit setting methodology (Environment Agency 2005) to calculate the annual

- worst-case plant discharge (WCPD), which they have rounded to give their proposed limit. (ERs6.1.3)
- 430 Westinghouse proposes an annual limit of 7 GBq for carbon-14 in aqueous radioactive waste discharges. (ER Figure 6.1-9 and ER Table 6.1-8)
- 431 We have limited information about carbon-14 discharges from PWRs operating over the last 10 to 15 years and we consider that the range of discharges to water of carbon-14 is 3 to 45 GBq y^{-1} for a 1000 MWe power station (see Annex 3). The predicted annual average aqueous discharge of carbon-14 from AP1000 is 3.3 GBq, well within this range. We conclude that aqueous discharge of carbon-14 from the AP1000 is comparable to other power stations across the world.
- 432 Westinghouse estimates that the radiological impact from the representative 12-month plant discharge of carbon-14 to sea will result in a dose to the local fisherman family of 1.6 $\mu\text{Sv } y^{-1}$. (ER table 5.2-1)
- 433 We have independently calculated limits for carbon-14 discharges that we may grant and, based on the information Westinghouse has provided for GDA, our proposed disposal limit for carbon-14 by discharge to the sea is 7 GBq in any 12 rolling calendar months. There is no limit for carbon-14 in aqueous radioactive waste from Sizewell B, however there is a requirement to use BAT to minimise discharges.
- 434 Based on the information Westinghouse has provided for GDA, our proposed quarterly notification level for carbon-14 is 2.5 GBq.

10.6 Iodine radionuclides

- 435 Iodine radionuclides are formed in the fuel and are only present in the coolant in the event of fuel cladding defects. While it is not their primary function, the mixed bed demineralisers in the CVS purification loop will remove significant amounts of iodine radionuclides (BAT Assessment form 5).
- 436 Westinghouse claims that the only technique that might be used to further reduce iodine radionuclides in aqueous radioactive waste is chemical trapping. This would add appropriate chemicals that trap iodine (for example, hydrazine hydrate) to the spray system or to the reactor sump. Westinghouse claims that chemical trapping is not a developed technique, and costs to develop the technology and apply it to the AP1000 would be significant and difficult to justify against the impact of unabated discharges.
- 437 Westinghouse has provided little detail on the techniques for abatement of iodine radionuclides in aqueous radioactive waste discharges from the AP1000. However, we recognise that using demineralisers may contribute to reducing the amount of iodine radionuclides in aqueous radioactive waste.
- 438 ER Table 3.4-6 gives the expected annual release of iodine radionuclides in liquid effluent discharged to the sea as:
- iodine-131 – 0.015 GBq, half-life 8 days;
 - iodine-132 – 0.020 GBq, half-life 2.3 hours;
 - iodine-133 – 0.029 GBq, half-life 20.8 hours;
 - iodine-134 – 0.006 GBq, half-life 52.6 minutes;
 - iodine-135 – 0.024 GBq, half-life 6.61 hours.
- 439 The short half-lives of the iodine radionuclides other than iodine-131 mean they rapidly become insignificant and only iodine-131 is usually considered.
- 440 We have limited information about iodine discharges from PWRs operating over the last 10 to 15 years and we consider that the range of discharges to water of iodine radionuclides is 0.01 to 0.03 GBq per annum for a 1000 MWe power station (see

Annex 3). The predicted aqueous discharge for iodine 131 is 0.015 GBq, which is within this range. We conclude that aqueous discharge of iodine radionuclides from the AP1000 is comparable to other power stations across the world.

441 Westinghouse does not propose an annual disposal limit to sea for iodine radionuclides.

442 Westinghouse has not assessed the impact in terms of dose resulting from the disposal of iodine radionuclides by discharge to the sea. (ER table 5.2-1)

443 We do not consider that a specific limit should be set for iodine radionuclides in aqueous radioactive waste discharges but in the permit we grant we will require that operators demonstrate that BAT is used to minimise the amount of all radionuclides including iodine radionuclides discharged in liquid waste.

10.7 Other radionuclides

444 Aqueous radioactive waste can contain other radionuclides as well as those specifically considered above. These include activation products and fission products. Activation products, for example cobalt-58 and cobalt-60, may be formed by neutron activation of materials within the reactor which may be released into the coolant by corrosion processes and may be present dissolved in the coolant or as particulate material. The reactor materials and coolant chemistry are chosen to minimise both the potential for activation and corrosion. Fission products, for example, caesium-137 may enter the coolant in the event of a fuel pin failure. The coolant is recycled through filters and demineralisers in the purification loop of the CVS to remove suspended and dissolved radioactive materials. However, low concentrations are still found in managed discharges and minor leaks of coolant reaching the WLS.

445 **Strontium-90** is released into the coolant in the event of fuel pin failure. The mixed bed demineraliser and filters in the WLS will remove strontium from aqueous radioactive waste. (BAT assessment form 4)

446 Westinghouse identifies the following abatement techniques for strontium-90 in aqueous radioactive waste:

- a) ion exchange;
- b) wet scrubbing;
- c) no abatement– direct discharge of aqueous radioactive waste to the environment;
- d) evaporation;
- e) precipitation/filtration;
- f) adsorption;
- g) isotopic concentration/separation;
- h) delay tank– delay tanks could be used to delay discharges to take advantage of radioactive decay.

447 Westinghouse claims that the most effective techniques for abating strontium-90 is ion exchange. The AP1000 design includes ion exchange, although it is recognised that the choice of ion exchange resin in the AP1000 is not specifically aimed at strontium-90 removal but is optimised over a range of radionuclides.

448 Westinghouse provides little detail on the techniques for abatement of strontium-90 in aqueous radioactive waste discharges from the AP1000. We consider the optioneering study does not contain enough detail to identify the best option, however we recognise that ion exchange is likely to be the best option.

449 Westinghouse predicts that the annual average discharge of strontium-90 from the AP1000 to sea will be 0.00025 GBq. (ER Table 3.4-6)

- 450 Westinghouse calculates a discharge limit for strontium-90 from the AP1000. They have predicted monthly discharges over an 18-month cycle and used data from the 12 months in which the discharges are highest (month 7 – 18) to calculate representative 12-month plant discharge to be 0.00324 GBq. Westinghouse has applied our limit setting methodology (Environment Agency 2005) to calculate the annual worst-case plant discharge (WCPD), which they have rounded to give its calculated limit. (ERS6.1.3)
- 451 Westinghouse calculates an annual limit of 0.0005 GBq for strontium-90 in liquid discharges. (ER Figure 6.1-3 and ER Table 6.1-6)
- 452 Westinghouse estimates that the radiological impact from representative 12-month plant discharge of strontium-90 to sea will result in a dose to the local fisherman family of $1.5 \text{ E-6 } \mu\text{Sv y}^{-1}$. (ER table 5.2-1)
- 453 We do not consider that a specific limit should be set for strontium-90 in aqueous radioactive waste discharges, but in the permit we grant we will require that operators demonstrate that BAT is used to minimise the amount of all radionuclides, including strontium-90 discharged in liquid waste. Strontium-90 is included in the limit we set for 'all other radionuclides (excepting tritium, carbon -14, cobalt-60 and caesium-137)'.
- 454 There is no limit for strontium-90 in aqueous radioactive waste from Sizewell B, however there is a requirement to use BAT to minimise discharges.
- 455 **Caesium-137** is a fission product which may be present in aqueous radioactive waste as a result of fuel failure or from tramp uranium.
- 456 Westinghouse considers the following abatement techniques for caesium-137 aqueous radioactive waste (BAT assessment form 6):
- a) Demineralisation - zeolite beds and cation resins can remove caesium isotopes. During normal operation the reactor coolant contains lithium hydroxide and the demineraliser in the CVCS used to routinely clean-up reactor coolant on-load can be saturated with lithium ions, making it less effective at removing some radionuclides including caesium-137. A cation resin bed demineraliser located downstream of the mixed bed demineralisers can be used intermittently to control the concentration of lithium-7 (pH control) and caesium concentration in the reactor coolant system.
 - b) Filtration – filtration can be used for removing insoluble species, but most caesium radionuclides are soluble in water, therefore filtration has limited application for removing caesium.
 - c) No abatement – direct discharge of aqueous radioactive waste to the environment.
- 457 Westinghouse claims that demineralisation is BAT for caesium-137. It recognises that demineralisation costs more than direct discharge and will produce secondary waste. But, this is outweighed by reduction in doses to members of the public and environmental impact, bearing in mind that the secondary waste is highly likely to be suitable for disposal as solid waste.
- 458 We consider that the techniques Westinghouse has considered for the abatement of caesium-137 in the AP1000 are comprehensive enough and represent feasible proven techniques.
- 459 **We conclude that Westinghouse has demonstrated that BAT is used to minimise discharges of caesium-137 in aqueous radioactive waste from the AP1000.**
- 460 Westinghouse predicts that the annual average discharge of caesium-137 from the AP1000 to sea will be 0.023 GBq. (ER Table 3.4-6)
- 461 Westinghouse calculates a discharge limit for caesium-137 from the AP1000. It has predicted monthly discharges over an 18-month cycle and used data from the 12 months in which the discharges are highest (month 7 – 18) to calculate the representative 12-month plant discharge to be 0.0301 GBq. Westinghouse has

- applied our limit setting methodology (Environment Agency 2005¹) to calculate the annual worst-case plant discharge (WCPD), which they have rounded to give its calculated limit. (ERs6.1.3)
- 462 Westinghouse calculated an annual limit of 0.05 GBq for caesium-137 in liquid discharges. (ER Table 6.1-6)
- 463 Westinghouse estimates that the radiological impact from the representative 12-month plant discharge of caesium-137 to sea will result in a dose to the local fisherman family of $3.4 \text{ E-3 } \mu\text{Sv y}^{-1}$. (ER table 5.2-1)
- 464 We have independently calculated limits for caesium-137 discharges that we may grant and, based on the information Westinghouse has provided for GDA, our proposed disposal limit for caesium-137 by discharge to the sea is 0.05 GBq in any 12 rolling calendar months. The current limit for caesium-137 in aqueous radioactive waste from Sizewell B is 20 GBq.
- 465 Based on the information Westinghouse has provided for GDA, our proposed quarterly notification level for caesium-137 is 0.018 GBq.
- 466 **Plutonium-241** can be produced by successive neutron capture of uranium in the AP1000. (BAT assessment form 7)
- 467 Westinghouse identifies the following abatement options for plutonium-241:
- a) filtration/ion exchange;
 - b) evaporation;
 - c) fuel storage pool cooling and clean up system - The fuel storage pool water chemistry can be controlled to minimise fuel-clad corrosion and minimise the release of radioactivity into the pool water;
 - d) monitoring of discharges delay tank – delay tanks can be used to delay discharges to take advantage of radioactive decay;
 - e) adsorption;
 - f) wet scrubbing;
 - g) no abatement – direct discharge of aqueous radioactive waste to the environment;
 - h) precipitation.
- 468 Westinghouse claims that using filtration and ion exchange and using the fuel storage pool cooling and clean up system along with monitoring of discharges is BAT for plutonium-241. Westinghouse claims that in the event of a higher than normal level of plutonium-241 in the aqueous radioactive waste the discharge would be terminated.
- 469 We do not consider that monitoring of discharges is an abatement technique, however we recognise that filtration/ion exchange and using the fuel storage pool cooling and clean up system will provide abatement for plutonium-241.
- 470 Westinghouse predicts that the annual average discharge of plutonium-241 from the AP1000 to sea will be 0.00008 GBq. (ER Table 3.4-6)
- 471 Westinghouse calculates a discharge limit for plutonium-241 from the AP1000. It has predicted monthly discharges over an 18-month cycle and used data from the 12 months in which the discharges are highest (month 7 – 18) to calculate representative 12-month plant discharge to be 0.000108 GBq. Westinghouse has applied our limit setting methodology (Environment Agency 2005) to calculate the annual worst-case plant discharge (WCPD), which they have rounded to give its calculated limit. (ERs6.1.3)
- 472 Westinghouse calculates an annual limit of 0.0002 GBq for plutonium-241 in aqueous radioactive waste discharges (ER Table 6.1-6)

- 473 Westinghouse estimates that the radiological impact from representative 12-month plant discharge of plutonium-241 to sea will result in a dose to the local fisherman family of $2.7 \text{ E-6 } \mu\text{Sv y}^{-1}$. (ER table 5.2-1)
- 474 We do not consider that a specific limit should be set for plutonium-241 in aqueous radioactive waste discharges, but in the permit we grant we will require that operators demonstrate that BAT is used to minimise the amount of all radionuclides, including plutonium-241 discharged in aqueous radioactive waste. Plutonium-241 is included in the limit we set for 'all other radionuclides (excepting tritium, carbon -14, cobalt-60 and caesium-137)'.
- 475 There is no limit for plutonium-241 in aqueous radioactive waste from Sizewell B however there is a requirement to use BAT to minimise discharges.
- 476 **Beta emitting particulates** - Westinghouse provides a review of other techniques that are available for removing particulates in liquid such as (BAT Assessment form 9):
- flocculation;
 - particulate separation;
 - evaporation – Westinghouse claims operational experience has shown problems, and that drawbacks outweigh the benefits;
 - precipitation/filtration;
 - using a hydrocyclone;
 - mixed bed demineralisers;
 - ultrasonic fuel cleaning;
 - minimising plant shutdown.
- 477 Westinghouse claims the most effective option for abating beta emitting particulates in aqueous radioactive waste is to minimise plant shutdowns, because plant shutdowns perturb the corrosion characteristics of the primary circuit and may cause more corrosion products to enter the coolant. This, taken with an increase in the amount of effluent for processing as a result of additional letdown, increases the amount of beta emitting particulates in the aqueous radioactive waste. In addition, the AP1000 design includes mixed bed demineralisers.
- 478 Westinghouse claims that the other techniques they have considered are not particularly effective and would be costly to implement and are not included in the AP1000 design.
- 479 **We conclude that the techniques Westinghouse has considered for the abatement of fission and activation products in the AP1000 are comprehensive enough and represent feasible techniques at this stage. However, we recognise that techniques may be developed in the future which may be worth considering.**
- 480 Westinghouse predicts that the annual average discharge of the following activation and fission products from the AP1000 to sea will be: (ER Table 3.4-6)
- iron-55 – 0.49 GBq
 - cobalt-58 – 0.41 GBq
 - cobalt-60 – 0.23 GBq
 - nickel-63 – 0.54 GBq
 - other activation and fission products - 1 GBq.
- 481 Westinghouse calculates discharge limits for activation and fission products from the AP1000. It has predicted monthly discharges over an 18-month cycle and used data from the 12 months in which the discharges are highest (month 7 – 18) to calculate representative 12-month plant discharge (Table 6.1-6). Westinghouse has applied our

- limit setting methodology (Environment Agency 2005) to calculate the annual worst-case plant discharge (WCPD), which they have rounded to give its calculated limit. (ERs6.1.3)
- 482 Westinghouse has calculated annual limits for the following radionuclides in liquid discharges: (ER Figure 6.1-3 and ER Table 6.1-6)
- a) iron-55 – 1.0 GBq
 - b) cobalt-58 – 0.9 GBq
 - c) cobalt-60 – 0.5 GBq
 - d) nickel-63 – 1.0 GBq
 - e) other activation and fission products - 2 GBq.
- 483 We examined historic discharges (where available) from European and US PWRs operating over the last 10 to 15 years and we consider that the range of discharges to water of fission and activation products is of 0.5 to 5 GBq per annum for a 1000 MWe power station (see Annex 3). The predicted annual average aqueous discharge of other radionuclides from AP1000 is within this range. We conclude that the aqueous discharge of other radionuclides from the UK AP1000 is comparable to other power stations across the world.
- 484 Westinghouse estimates that the radiological impact from representative 12-month plant discharge of iron-55, cobalt-58, cobalt-60 and nickel-63 to sea will result in a dose to the local fisherman family of $0.67 \mu\text{Sv y}^{-1}$. (ER table 5.2-1)
- 485 We have independently calculated limits for discharges of cobalt-60, and 'all other radionuclides (excepting tritium, carbon -14, cobalt-60 and caesium-137)' that we may grant and, based on the information Westinghouse has provided for GDA, our proposed disposal limits for activation and fission products by discharge to the sea in any 12 rolling calendar months are:
- a) cobalt-60 – 0.5 GBq;
 - b) all other radionuclides (excepting tritium, carbon-14, cobalt-60 and caesium137) taken together – 5 GBq.
- 486 There is no individual limit for cobalt-60 in aqueous radioactive waste from Sizewell B, however there is a requirement to use BAT to minimise discharges.
- 487 The current limit for all other isotopes without limits in aqueous radioactive waste from Sizewell B is 130 GBq.
- 488 Based on the information Westinghouse has provided for GDA, our proposed quarterly notification level for cobalt-60 is 0.18 GBq and for 'all other radionuclides (excepting tritium, carbon-14, cobalt-60 and caesium-137) taken together' is 1.8 GBq.

10.8 Aqueous radioactive waste disposal to the environment

489 The effluent system of the AP1000 is shown in ER Figure 6.2-2 repeated below as Figure 10.2:

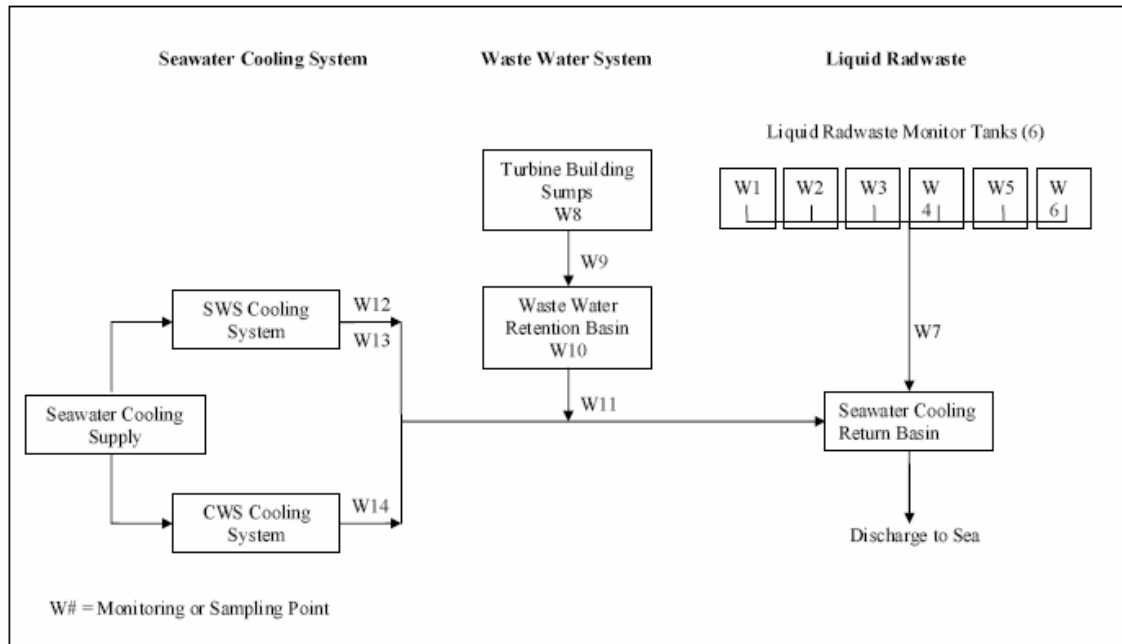

Figure 10.2: AP1000 effluent system (ER Fig 6.2-2)

490 We would place controls on four effluent release points in a permit:

- W7 – discharge for liquid radwaste monitor tanks serving the WLS;
- W11 – discharge line of the wastewater system (WWS) from the wastewater retention basin;
- W14 – discharge line of the circulating water system (CWS);
- W12 – discharge line of the service water system (SWS).

491 Treated radioactive effluent from the WLS is collected in six monitor tanks, each with a usable capacity of 57 m³, located in the auxiliary and radwaste buildings. Westinghouse claims that the average daily radioactive liquid waste arisings are approximately 8 m³. The monitor tanks will, therefore, provide up to 42 days typical storage capacity in normal operation. This storage period will be longer for most operations but reduced for short periods during higher discharges associated with refuelling. (ERs3.4.3.6)

492 There are no direct continuous discharges from the WLS to the sea. When a tank needs to be discharged, its contents are sampled and analysed. Data on the volume and activity of contained radionuclides are used to decide if discharge can be permitted. All data will need to be recorded as operational records – a permit condition. The monitor tank discharge pumps have a design flow rate of 22.7 m³ h⁻¹. We will require the final common discharge line to be fitted with an MCERTS (our certification system for measuring equipment) flowmeter and flow proportional sampler to provide permit compliance data, our release point W7. A radiation monitor will also be installed on the discharge line.

493 The disposal route is initially to join the high volume direct sea water cooling flow (136275 m³ h⁻¹). The combined flow is then sent to an outfall discharging some distance out from the shore. While we do not accept dilution as a reduction technique, once discharges have been minimised by other techniques, pre-dilution in a large flow before discharge to the environment is acceptable to reduce initial concentrations before dispersion in the receiving waters.

- 494 The design and location of outfalls will be a highly site-specific issue. The operator for each specific site will need to demonstrate by modelling that the outfall proposed will be BAT for adequate dispersion in local waters.
- 495 The WWS, the CWS and the SWS should contain only non-radioactive wastewater in normal operation. Only in the event of steam generator tube leaks is there any possibility of these waters being contaminated with radioactivity.
- 496 The WWS collects normally non-radioactive waste water into the turbine building sumps. There is a radiation monitor (W9) on the common discharge line from the sumps to the wastewater retention basin (WWRB). If activity is detected the wastewater is diverted to the WLS.
- 497 The contents of the WWRB are only discharged intermittently after sampling and analysis to confirm discharge can be permitted. The discharge line will need to be fitted with an MCERTS flowmeter and flow proportional sampler to provide permit compliance data, release point W11.
- 498 The CWS is a high volume once through seawater cooling system for the main condensers. There will be a sampling point on the discharge of this system, release point W14. We believe the risk of radioactivity at this point will be minimal and do not intend to impose any disposal limits. Periodic spot sampling will be required at W14 to confirm no significant contamination has taken place.
- 499 The SWS is a much lower volume once through seawater cooling system for cooling water used for cooling components in the turbine building. There will be a sampling point on the discharge of this system, release point W12. There will also be a continuous radiation monitor installed at W13. If radiation levels detected are above acceptable levels the operator will need to take action. We believe the risk of radioactivity at this point will be minimal and do not intend to impose any disposal limits. Periodic spot sampling will be required at W12 to confirm no significant contamination has taken place.

11 Solid radioactive waste

500 We conclude that:

- a) In its submission, Westinghouse describes how low level waste (LLW) and intermediate level waste (ILW) will be generated, managed and disposed of throughout the facility's lifecycle.
- b) Westinghouse has identified all LLW and ILW waste streams that an AP1000 will typically produce.
- c) Waste will be treated and conditioned using proven and recognised techniques. However, HSE will be looking at Westinghouse's plans for the conditioning of waste produced by an AP1000 in more detail as part of its Step 4 assessment, and our final decision will be informed by this work.
- d) The design is not expected to produce LLW and ILW for which there is no foreseeable disposal route. However, the regulators need more information on the potential for degradation of ILW over the longer term that might affect its disposability and safe storage. Westinghouse provided information on 1 March 2010, and whilst our views are presented in this consultation document, we note HSE is continuing to review this information in its Step 4 assessment. We will continue to work with HSE on this, and this work will inform our decision document.
- e) Westinghouse has provided estimates for the annual arisings (during operations and decommissioning) of LLW and ILW. These arisings (during operations) are consistent with those of comparable reactors around the world (Isukul, 2009).
- f) Westinghouse has provided basic evidence of how they will minimise the disposal of LLW and ILW.

501 However, our conclusion is subject to the following two other issues:

- a) Disposability of ILW following longer term interim storage pending disposal (AP1000-OI06)
- b) Providing evidence at site-specific permitting that the specific arrangements for minimising the disposals of LLW and ILW for each site represents BAT (AP1000-OI07).

Consultation Question 6: Do you have any views or comments on our preliminary conclusions on solid radioactive waste?

11.1 Creation of solid waste

502 The sources of solid radioactive waste generated in the AP1000 are summarised in Table 3.5-1 in the ER and a detailed breakdown of the wastes can be found in Appendix A of the ER.

503 Westinghouse provides information in section 3.5.3.1 of the ER about LLW, which includes dry active wastes, general trash and mixed waste as a result of normal plant operation. Section 3.5.3.1 of the ER states that waste will generally contain: plastics, paper, metallic items, clothing, rubber, filters, redundant equipment, glass and wood.

504 In section 3.5.3.2 of the ER, Westinghouse states that ILW comprises mainly of spent ion exchange resins, activated carbon and used filters. It states that the production of these wastes is intermittent and associated with replacement and maintenance procedures.

- 505 The quantities of solid radioactive waste generated by the AP1000 are summarised in ER Table 3.5-1.
- 506 Westinghouse states in ER section 3.5.3 that the solid radioactive waste estimates in the ER are best, realistic estimates. A major source of information for its calculations was consultations with experienced personnel who have worked in the design of the AP1000 and worked on existing plants.
- 507 The estimated gross annual volumes of solid LLW produced during the operation and maintenance of the AP1000 is 163.98 m³ and the estimated volume of treated LLW to be disposed of or stored per year is 61.14 m³. Therefore, for the conditioned waste, assuming the AP1000 design is for a single, pressurised water reactor (PWR) capable of generating in total 1117 MW of electricity, the estimated volume is 54.7 m³ per 1000 MWe plant-year of operation.
- 508 The estimated gross annual volumes of solid ILW produced during the operation of the AP1000 is 10.25 m³ and the estimated volume of final solid ILW packages to be disposed of or stored per year is 40.86 m³. Therefore, for the conditioned waste, assuming the AP1000 design is for a single, pressurised water reactor (PWR) capable of generating in total 1117 MW of electricity, the estimated volume is 36.6 m³ per 1000 MWe plant-year of operation.
- 509 The IWS states that solid ILW decommissioning waste will be handled in a similar way to that used for operational and maintenance waste, but with a size reduction stage incorporated to allow larger waste items (for example, structural steel) to be processed into a form that allows immobilisation.
- 510 The quantities and classification of decommissioning waste associated with the AP1000 are shown in Appendix A3, Appendix A4 and Appendix A6, and summarised in Table 3.5-10 of the ER. An estimated volume of LLW from decommissioning is around 5500 - 6000 m³. An estimated volume of ILW from decommissioning is 800 m³. A typical schematic for treatment of decommissioning waste is shown in Figure 3.5-21 of the ER.
- 511 The estimates in Westinghouse's submission for the volumes of operational LLW and ILW appear to be reasonable for the AP1000. These estimates were derived by Westinghouse using information from consultations with experienced personnel who have worked in the design of the AP1000 and worked on existing plants. Additionally, Westinghouse has provided a comparison of its estimated solid radioactive waste arisings against available operating plant experience in its response to TQ AP1000-383. This supplementary information provides confidence that the estimates are realistic for the UK AP1000.

11.2 Management and disposal of low level waste

- 512 In this section we cover our assessment of the management and disposal of low level radioactive wastes (LLW). LLW is defined in the UK as 'solid radioactive waste having a radioactive content not exceeding 4 GBq per tonne (GBq te⁻¹) of alpha or 12 GBq te⁻¹ of beta/gamma activity', but we also consider here some liquid waste such as contaminated oils. These types of low level waste are usually suitable for disposal at the low level waste repository (LLWR) near Drigg, disposal by on or off-site incineration, or transfer off-site for recovery (for example, of metals).
- 513 Having minimised the overall production of radioactive waste, the application of BAT to minimise the activity in gaseous and aqueous discharges tends to transfer activity to low (and intermediate – see below) level solid waste. This is in line with the principle of preferred use of 'concentrate and contain' over 'dilute and disperse' (DECC 2009a). There is little opportunity to reduce the activity of this waste, except by decay storage when the waste contains radionuclides with short half-lives. However, the volume of LLW requiring final disposal can be reduced by using techniques such as waste

sorting and segregation, compaction, incineration, removal of surface contamination, re-use and recycling.

514 A schematic of solid AP1000 waste management is given in Figure 3.5-2 of the ER, repeated below as Figure 11.1.

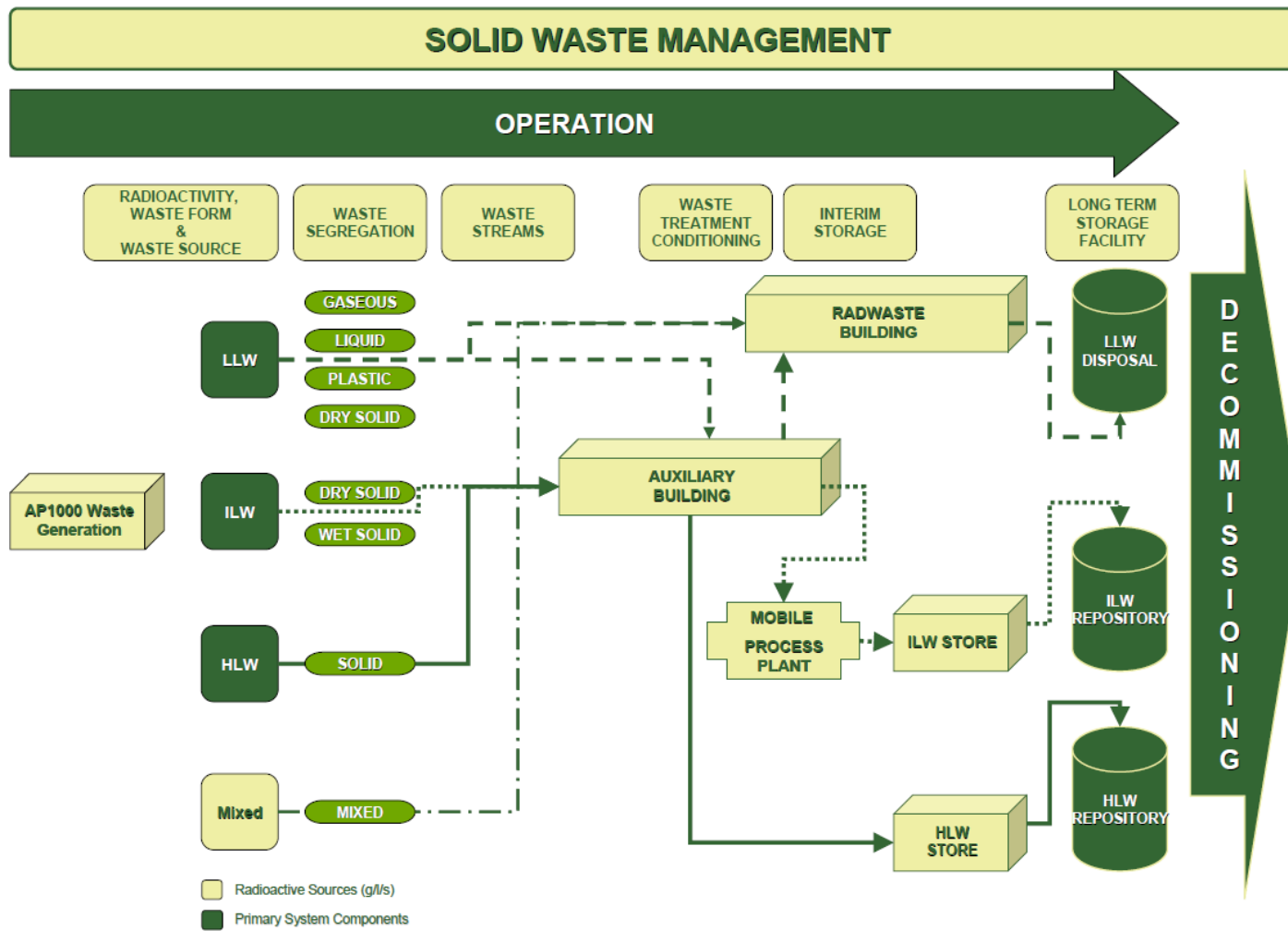

Figure 11.1: Solid AP1000 waste management (ER Fig 3.5-2)

- 515 Waste treatment of LLW is described in section 3.5.7.1 of the ER. LLW will be brought into the radwaste building and sorted to segregate the waste. Whenever possible, Westinghouse claims that waste items will be decontaminated to the extent that allows free release and handling as conventional waste. It also states that compactable LLW items will be sorted and compacted in metal 200 litre drums and non-compactable items will be cut into pieces to allow packing into metal 200 litre drums.
- 516 Westinghouse states in ER Section 3.5.7.1 that contaminated material that may arise from equipment replacement parts, tools and other metallic, plastics or cloth parts from outage operations would normally be classified as LLW. However, in the event that they were initially classified as ILW, the AP1000 plant includes provisions for the decontamination of these types of materials so that they can be decontaminated to a LLW category if feasible.
- 517 A schematic of the LLW processing in the radwaste building is given in Figure 3.5-9 of the ER.
- 518 In section 3.5.7.1 of the ER, Westinghouse states that full drums containing LLW will be assayed with a low resolution gamma spectroscope (LRGS) and placed into half height ISO (HHISO) containers. HHISO containers will be stored on site in the LLW buffer store before being shipped to the LLWR. Westinghouse states in its IWS that the combined capacity for HHISO containers within the buffer store and the radwaste building will provide up to two years of waste arisings. Off-site incineration is considered for certain LLW, for example, waste oil. Solid LLW disposal routes are shown in Figure 3.5-10 in the ER and a schematic of LLW oil disposal is in Figure 3.5-12 of the ER.
- 519 In section 3.5.1.3 of the ER, Westinghouse states that a range of appropriate options for waste treatment, such as evaporation, drying, incineration and cement encapsulation, were considered at an optioneering workshop. It documented the results of this workshop and the chosen options were substantiated. Further details of this (which Westinghouse also calls its BAT assessment) are given in section 3.5.5 of the ER. There is a schematic of LLW options in Figure 3.5-3 of the ER. The study recommended that compaction is adopted as the design option for the treatment of LLW. There is also a schematic of the summary of the selected BAT treatment systems for ILW and LLW waste in Figure 3.5-8 of the ER.
- 520 Disposal of LLW is briefly discussed in section 3.5.9.1 of the ER. Westinghouse will dispose of LLW to the LLWR. Westinghouse's IWS assumes that the national LLWR is available within two years of site operations commencing.
- 521 Westinghouse has completed LLWR form D1s (Request for Agreement in Principle to dispose of radioactive waste at the LLWR) for each of the AP1000 LLW streams. These forms describe the nature of the process producing the waste, the type of radioactive waste generated, the physical and chemical form of the waste, and its radiological characteristics.
- 522 Westinghouse has provided us with signed form D1s from the LLWR, giving agreement in principle for the treatment / disposal of the following LLW:
- a) CPS resin;
 - b) general LLW;
 - c) waste oil;
 - d) steam generator sludge.
- 523 The LLWR recognises that Westinghouse form D1 applications represent assumed waste disposals at some point in the future and, as such, it cannot guarantee future capacity today. However, the LLWR has assessed Westinghouse's application against its current arrangements and can give agreement in principle on the basis that this waste would be suitable for treatment / disposal against its current arrangements.

- 524 Although form D1s have been completed for all AP1000 operational LLW (condensate polishing (CPS) resin, general LLW, waste oil and steam generator sludge), Westinghouse has identified waste streams that are likely to be suitable for incineration to minimise the waste sent to the LLWR. The CPS resin form D1 was included as a contingency, as generally they are not expected to be contaminated, and are proposed to be treated in the high temperature incinerator at Fawley. The form D1 considers the case if the resin contamination prevents it from being accepted at this incinerator.
- 525 Off-site incineration is also considered for waste oil as described in ER section 3.5.7.1. Waste oil will normally be non-radioactive, however, in the event of the oil becoming contaminated with radioactivity it will be shipped to an appropriate incineration facility (for example, the Tradebe Incinerator at Fawley). Westinghouse has carried out a review of this contaminated oil against the conditions of acceptance of this incinerator and shown that they can be met. However, Westinghouse states in section 3.5.7.1 that if any waste oil exceeds the radioactivity acceptance thresholds of the incinerator, it will be solidified by mobile plant before being disposed of to the LLWR.
- 526 Westinghouse has considered the treatment and disposal of large, one-off solid radioactive waste items that could need replacing during the operation of the AP1000. It considers steam generators and reactor pressure vessel heads. Westinghouse states in section 3.5.7.1 that steam generators will be LLW and that they will be reduced in size in a temporary facility, placed in HHISO containers and sent for disposal at the LLWR. Westinghouse states in ER section 3.5.7.1 that the reactor pressure vessel head is not likely to have to be replaced during the operating lifetime but, if it is necessary, it will be treated in a similar way to steam generators.
- 527 In section 3.5.1.1 in the ER, Westinghouse summarises its waste minimisation strategy. It states that waste minimisation is an inherent part of waste management and that waste is minimised by:
- a) the design: The AP1000 was designed with fewer valves, pipes, and other components so less waste will be generated during maintenance activities (repair and replacement) and decommissioning.
 - b) material selection: For example, the level of cobalt in structures is limited to limit the activation of metal components, and surfaces (including steel wall and floor surfaces) will be sealed to prevent penetration and to facilitate decontamination.
- 528 In section 3.5.4.1 of the ER, Westinghouse states how the basic AP1000 design principles minimise the creation of LLW during operations and decommissioning, which are:
- a) good housekeeping;
 - b) operating procedures;
 - c) segregation;
 - d) volume reduction;
 - e) sealed surfaces (including steel wall and floor surfaces) to prevent penetration and to facilitate decontamination;
 - f) limiting the amount of material brought into containment;
 - g) training all staff allowed to enter radiation controlled areas;
 - h) providing waste facilities immediately outside of the radiation controlled areas, for the disposal of unnecessary packaging materials;
 - i) providing tool stores within the reactor containment area (RCA), to prevent contamination of clean tools brought in from outside;
 - j) testing filter performance to ensure filters are only replaced when necessary;

- k) providing radioactive waste advice on radiation work permits.
- 529 In section 3.5.5 of the ER, Westinghouse provides details of the BAT assessment that has been carried out on the radwaste treatment system. This addressed the waste activities from the transportation point of the 'nuclear island' through to dispatch to the ILW storage before disposal or to the LLW disposal.
- 530 Westinghouse states in its IWS that within the design of AP1000, there are many features that facilitate the eventual decommissioning of the plant. For example:
- a) reduced equipment numbers reduce the amount of waste that needs managing;
 - b) carefully selecting materials reduces activation of equipment and structure;
 - c) reduction in activated corrosion products by improved control of primary circuit water chemistry (ph range; 6.9-7.4) and suitable dosing regimes; for example, zinc acetate.
- 531 Westinghouse has provided evidence in its BAT assessment that BAT has been used to prevent and minimise at source generation of radioactive wastes for the AP1000. This includes information such as how the control of the choices of materials in contact with the primary coolant leads to a reduction in the production of corrosion products.
- 532 **Our conclusions:**
- a) **In its submission, Westinghouse describes how LLW will be generated, managed and disposed of throughout the facility's lifecycle.**
 - b) **Westinghouse has identified all LLW waste streams that an AP1000 will typically produce.**
 - c) **Waste will be treated and conditioned using proven and recognised techniques. However, HSE will be looking at Westinghouse's plans for the conditioning of waste produced by an AP1000 in more detail as part of its Step 4 assessment, and our final decision will be informed by this work.**
 - d) **The design is not expected to produce LLW for which there is no foreseeable disposal route. Westinghouse has demonstrated that the waste streams would meet the criteria for disposal in a LLW facility or an incineration facility.**
 - e) **Westinghouse has provided estimates for the annual arisings (during operations and decommissioning) of LLW. The arisings of ILW and LLW exceed the European Utility Requirement (European Utility Requirements for LWR Nuclear Power Plants Rev C Apr 2001 (Volume 2 chapter 2, section 5.2)) objective of $\leq 50\text{m}^3$ per 1000 MWe plant-year of operation, although the operational arisings are consistent with those of comparable reactors around the world (Isukul, 2009).**
 - f) **Westinghouse has provided basic evidence of how it will minimise the disposal of LLW. This includes appropriate characterisation and segregation. Further detailed evidence is required at site-specific permitting (other issue AP1000-OI07).**

11.3 Management and disposal of intermediate level waste

- 533 In this section we cover our assessment of the management of intermediate level radioactive waste (ILW). ILW is waste with activity levels exceeding the upper boundaries for low level waste, but which does not require heat generation to be accounted for in the design of disposal or storage facilities. There are currently no final disposal facilities for ILW in the UK. However, the Government has stated (BERR 2008a) that it is satisfied that:
- a) a geological disposal facility would provide a possible and desirable mechanism for disposing of higher level waste (both from a new nuclear programme and existing legacy waste);
 - b) there are feasible and long-term mechanisms through the Managing Radioactive Waste Safely (MRWS) (Defra et al 2008) programme for identifying a suitable site and for constructing a geological disposal facility.
- 534 Although a permit for final disposal may not be required for a considerable time, we expect Westinghouse to show now whether the waste is:
- a) likely to be suitable for disposal in a geological repository;
 - b) will be appropriately managed in the interim, so as not to prejudice its ultimate disposal.
- 535 A schematic of solid AP1000 waste management is given in Figure 3.5-2 of the ER. Waste treatment of ILW is described in section 3.5.7.2 of the ER and shown in the schematic in Figure 3.5-13.
- 536 ILW will be segregated on an AP1000 nuclear site in the following ways:
- a) ion exchange and spent activated carbon will be monitored and sent to spent resin tanks;
 - b) replacement filter cartridges and any ILW filters will be placed in a Radioactive Waste Management Directorate (RWMD) approved box.
- 537 In section 3.5.1.3 of the ER, Westinghouse states that a range of appropriate options for waste treatment, such as evaporation, drying, incineration and cement encapsulation, was considered at an optioneering workshop. It documented the results of this workshop and the chosen options were substantiated. Further details of this (which Westinghouse also calls its BAT assessment) are given in section 3.5.5 of the ER. There is a schematic of ILW organic resin treatment options in Figure 3.5-4 of the ER and a schematic of ILW filter treatment options in Figure 3.5-7 of the ER. There is also a schematic of the summary of selected BAT for ILW and LLW waste in Figure 3.5-8 of the ER. The solid ILW will be immobilised in a cementitious grout within a RWMD approved container (drums or boxes). Westinghouse's BAT assessment concluded that solid ILW should be encapsulated in cement, stored and ultimately disposed of to a national ILW repository.
- 538 Hence, the spent ion exchange resin and/or activated carbon will be immobilised in a cementitious grout formulation within a RWMD approved drum. The spent filters, etc., will be immobilised in a cementitious grout formulation within a RWMD approved box. The waste encapsulation will be carried out using a mobile encapsulation facility on a campaign basis. The ILW waste packages will be subject to monitoring checks using a high resolution gamma spectroscope (HRGS) to produce a 'fingerprint' of the activity concentrations within the waste packages. Once the cement in the containers has set and passed quality assurance checks, they will be transported to the on-site ILW storage building. The boxes and drums will be stored here until a national ILW repository becomes available. A schematic of ILW treatment and disposal is given in Figure 3.5-13 of the ER.

- 539 Westinghouse claims that the ILW store will be designed for a total inventory of 60 years of operational waste arisings from one AP1000 unit and it will have a 100-year design life.
- 540 ILW will be stored on the sites in dedicated building(s) until a final disposal site for ILW is opened in the UK.
- 541 Westinghouse states in ER section 3.5.8.2 that when a national ILW repository becomes available, it will monitor the waste packages by HRGS before transportation. If the HRGS result of a package indicates that the radionuclides in the package have decayed such that the package could be LLW, the package will be temporarily placed in a LLW storage area. If suitable, these will be disposed of to the LLWR, which will reduce the final quantities of ILW to be disposed of. However, Westinghouse expects that all waste packages sent to the ILW store will remain ILW.
- 542 Westinghouse's proposals for storage of ILW are based on current practice. However, the regulators have requested further information about the proposed storage facilities to support the long-term safe storage of ILW and to ensure ILW does not degrade over the long storage period.
- 543 Disposability of operational ILW is briefly discussed in section 3.5.9.2 of the ER. In order to assess the disposability of ILW, Westinghouse provided the Nuclear Decommissioning Authority (NDA) with a datasheet for each of the AP1000 waste streams. Each datasheet included information on the nature of the waste stream, rate of arising, proposed matrix, package type, physical and chemical composition and radionuclide inventory, package heat output and external dose rate. Westinghouse has provided us with datasheets for the following operational waste types:
- a) filter cartridges (ILW);
 - b) primary resins (ILW);
 - c) mixed resins (ILW).
- 544 Westinghouse has provided us with a datasheet for decommissioning waste.
- 545 Westinghouse has obtained and provided a view from the RWMD of the Nuclear Decommissioning Authority (NDA) (as the UK authoritative source) on the disposability of its proposed arisings of ILW. RWMD concluded that compared with legacy waste, no new issues arise that challenge the fundamental disposability of the waste expected to arise from operation of the AP1000 (See Annex 5). Westinghouse also provided the regulators with its critique of the RWMD disposability assessment, and this is available on its website.
- 546 The regulators requested Westinghouse to make a case for the disposability of spent fuel and ILW, which demonstrates the following:
- a) How the issues identified in its critique of RWMD's Disposability Assessment will be addressed.
 - b) How the issues in Appendix B of RWMD's Disposability Assessment will be addressed.
 - c) How they will manage any risks associated with these issues
- 547 We received Westinghouse's response on 1 March 2010. We note in particular that Westinghouse has consulted with potential operators of the AP1000 on when they would expect to address issues and we recognise that, in most cases, these issues will need to be addressed by future operators of AP1000s, rather than by Westinghouse. It might have been prudent to discuss the timing of resolution of these issues with RWMD, to check how the planned timing fits with its usual expectation for the Letter of Compliance (LoC) process.
- 548 In general, we consider the plans proposed by Westinghouse to address – or, more commonly, for future licensees to address – outstanding disposability issues to be

adequate at this stage. We will expect these plans to be periodically refined and updated in future to reflect developments.

549 We note that Westinghouse has produced a 'RWMC Evidence Report', intended to indicate where the information that will be needed for future Radioactive Waste Management Cases (RWMCs) will come from, and when. This document gives us some assurance at this stage that RWMCs can be compiled at relevant stages in the development of an AP1000 fleet, which is sufficient at this stage of the GDA process. We note, however, that the RWMC evidence report in its current form would not yet fully meet our expectations for the format and content of a RWMC.

550 HSE is reviewing information on long term storage of ILW in its Step 4 assessment. We will continue to work with HSE on this, and this work will inform our decision document.

551 Westinghouse states in section 3.5.4.2 of the ER that ILW will be minimised by the following activities:

- a) optimum operation of the reactor in terms of power generation per tonne of fuel;
- b) select fuel with minimal potential for fuel defects, thereby minimising the radioactive isotope contamination of the primary cooling water circuit. This will reduce load being treated by the ion exchange resin beds and hence the volume of ILW;
- c) fuel is received and carefully inspected for any imperfections;
- d) minimisation of plant shutdowns;
- e) use of grey rods for mechanical shim control;
- f) use of canned coolant pumps eliminates seal leaks and creation of radioactive wastewater;
- g) selecting materials with a composition low in cobalt;
- h) using zinc addition for corrosion control;
- i) selecting ion exchange media to give optimum decontamination factor (DF), which will:
 - i) minimise the number of ion exchange media changes required and reduce the waste volume;
 - ii) give flexibility in routing effluent through the different ion exchange beds to optimise resin uptake.
- j) testing filter performance to make sure filters are only replaced when necessary;
- k) segregation procedures to prevent dilution of ILW streams by mixing them with LLW streams;
- l) formulation trials to determine optimum blend ratio producing the optimum number of waste packages;
- m) operating procedures.

552 Westinghouse states in its RWMC document that minimisation is an important initial step in waste management, and AP1000 operational procedures will seek to design, construct, operate, and decommission the plant in such a way that both the waste volume and radioactivity are minimised. It states that this will be achieved on the AP1000 nuclear site by activities such as:

- a) optimum operation of the reactor in terms of power generation per tonne of fuel, minimise fuel defects, and hence, minimise the activity of primary cooling water circuit, which in turn, minimises volumes of spent ion exchange resin;
- b) good housekeeping: for example, minimising the amount of material brought into containment;

- c) selecting ion exchange media to give optimum decontamination factor, which will minimise the number of ion exchange media changes required and reduce the waste volume;
- d) formulation trials to determine blend ratio producing the optimum number of waste packages;
- e) operating procedures.

553 Westinghouse has provided evidence in its BAT assessment that BAT has been used to prevent and minimise at source generation of radioactive wastes for the AP1000. This includes information such as how the control of the choices of materials in contact with the primary coolant leads to a reduction in the production of corrosion products.

554 **We conclude that:**

- a) **In its submission, Westinghouse describes how ILW will be generated, managed and disposed of throughout the facility's lifecycle.**
- b) **Westinghouse has identified all ILW waste streams that an AP1000 will typically produce.**
- c) **Waste will be treated and conditioned using proven and recognised techniques. However, HSE will be looking at Westinghouse's plans for the conditioning of waste produced by an AP1000 in more detail as part of its Step 4 assessment, and our final decision will be informed by this work.**
- d) **The design is not expected to produce ILW for which there is no foreseeable disposal route. However, the regulators need more information on the potential for degradation of ILW over the longer term that might affect its disposability and safe storage. Westinghouse provided information on 1 March 2010, and whilst our views are presented in this consultation document, we note HSE is reviewing this information in its Step 4 assessment. We will continue to work with HSE on this, and this work will inform our decision document. Therefore, the disposability of ILW following longer term interim storage pending disposal is an issue that continues to need addressing (other issue AP1000-OI06).**
- e) **Westinghouse has provided estimates for the annual arisings (during operations and decommissioning) of ILW. The arisings of ILW and LLW exceed the European Utility Requirement (European Utility Requirements for LWR Nuclear Power Plants Rev C Apr 2001 (Volume 2 chapter 2, section 5.2)) objective of $\leq 50\text{m}^3$ per 1000 MWe plant-year of operation, although the operational arisings are consistent with those of comparable reactors around the world (Isukul, 2009).**
- f) **Westinghouse has provided basic evidence of how they will minimise the disposal of ILW. This includes appropriate characterisation and segregation. Further detailed evidence is required at site-specific permitting (other issue AP1000-OI07).**

12 Spent fuel

555 We conclude that in its submission, Westinghouse describes how spent fuel will arise, be managed and disposed of throughout the facility's lifecycle. Westinghouse provide information on the fuel composition and characteristics, and proposed fuel burn up. Westinghouse considered operating strategies in regard to spent fuel generation, and quantities of spent fuel that will arise. Information is provided in the submission and supporting documents on short and long-term management proposals for spent fuel. Westinghouse has obtained a view from the RWMD of the NDA on the disposability of the fuel and has provided its critique to the regulators.

556 Westinghouse provided detailed responses in regard to disposability in March 2010, and whilst our views are presented in this consultation document, we note HSE is reviewing this information in its Step 4 assessment. The regulators have also requested information about long term storage. We will continue to work with HSE on this, and this work will inform our decision document. Therefore, our conclusion is subject to the potential GDA Issue:

- a) Disposability of spent fuel following longer term interim storage pending disposal (AP1000-I3).

Consultation question 7: Do you have any views or comments on our preliminary conclusions on spent fuel?

557 In this section we cover our assessment of the creation and management of spent fuel. There are currently no final disposal facilities for spent fuel in the UK. However, the Government has stated (BERR, 2008a) that it is satisfied that:

- a) a geological disposal facility would provide a possible and desirable mechanism for disposing of higher level wastes (both from a new nuclear programme and existing legacy waste);
- b) there are feasible and long-term mechanisms through the MRWS (Defra et al 2008) programme for identifying a suitable site and for constructing a geological disposal facility.

558 Although a permit for final disposal may not be required for a considerable time, we expect Westinghouse to show now whether spent fuel:

- a) is likely to be suitable for disposal in a geological repository;
- b) will be appropriately managed in the interim, so as not to prejudice their ultimate disposal.

12.1 Creation of spent fuel

559 The AP1000 reactor core comprises 157 fuel assemblies. Each fuel assembly consists of 264 fuel rods in a 17x17 square array. The fuel rods consist of pellets of slightly enriched uranium dioxide in a zirconium based alloy, Zirlo tubing, which is plugged and seal welded at the ends to encapsulate the fuel. The fuel rods include integral fuel burnable absorbers which may be boride coated fuel pellets, or fuel pellets containing gadolinium oxide mixed with uranium oxide. The reactor control system uses rod cluster control assemblies, RCCAs, and grey rod cluster assemblies as burnable absorber rods. The assemblies include rodlets made from silver/indium/cadmium alloys. Core reactivity is controlled using boric acid which acts as a chemical

- poison dissolved in the coolant, rod cluster control assemblies, RCCAs, grey rod cluster assemblies and burnable absorbers. The initial enrichment of new fuel is up to 4.95 per cent in weight uranium-235.
- 560 New fuel is stored in the new fuel storage facility within the auxiliary building fuel handling area. New fuel assemblies are moved by the new fuel assembly handling tool into the new fuel assembly inspection area. Following inspection, the accepted new fuel assemblies are stored in the new fuel storage rack (and the spent fuel pool in the case of first time fuelling). The new fuel storage rack includes storage locations for 72 fuel assemblies with the maximum design basis enrichment. The racks include integral neutron absorbing material to maintain sub-criticality. The rack layout provides a minimum separation between adjacent fuel assemblies which is sufficient to maintain a sub-critical array even in the event the building is flooded with unborated water, or fire extinguishant aerosols, or during any design basis event. The rack sits on the floor of the new fuel storage pit which is covered to prevent foreign objects from entering the new fuel storage rack.
- 561 The new fuel handling crane is used to load new fuel assemblies into the new fuel rack and to transfer new fuel assemblies from the new fuel pit into the spent fuel pool. A gated opening connects the spent fuel pool and the fuel transfer canal. A fuel transfer tube connects the fuel transfer canal to the in-containment refuelling cavity.
- 562 A new fuel elevator in the spent fuel pool lowers the new fuel to an elevation accessible by the fuel handling machine (FHM). The FHM is part of the fuel transfer system which is used to transport up to two fuel assemblies at a time between the fuel handling area in the auxiliary building and the refuelling cavity in the containment building.
- 563 The FHM is used to perform fuel handling operations in the fuel handling area. Fuel is placed in a basket in the underwater transfer car to pass through the fuel transfer tube into the refuelling cavity.
- 564 The refuelling machine performs fuel handling operations in the containment building. Fuel is moved between the fuel transfer system and the reactor vessel by the refuelling machine. It withdraws the fuel from the refuelling cavity, moves over the core area and inserts the fuel assembly into a vacant core location. During refuelling the vacant core location is created by first removing a spent fuel assembly.
- 565 The initial fuel loading consists of 157 fuel assemblies for one AP1000 unit. Refuelling every 18 months requires an average of 68 assemblies for one unit; in fact the range can be between 64 to 68 fuel assemblies depending on fuel enrichment and operating conditions. Spent fuel assemblies are discharged from the reactor at every refuelling outage and are placed into the spent fuel pool. The spent fuel pool has the capacity to store 889 fuel assemblies. Each refuelling offload discharges 68 fuel assemblies. The spent fuel pool has the capacity for 10 refuelling offloads, which is approximately equal to 18 years of operation, plus one full core offload.
- 566 Operating strategies can influence the amount of spent fuel and the radioactivity of the spent fuel. The amount of spent fuel discharged over time is determined by the energy production rate, that is the overall capacity factor including outages, and the discharge burn up limit. Operating utilities may choose from various cycle lengths for AP1000. For example, annual or 18 month cycles. Depending on the requirements of the utility, if the main objective is to reduce the average number of discharge assemblies per year, then on average, an annual cycle would expend fewer assemblies; 40 when compared with 43 on an 18-month cycle. For a plant lifecycle of 60 years, this translates to a generation of 2400 or 2580 spent fuel assemblies for an annual and 18-month cycle respectively. However, depending on the cost of the extra outage every three years, together with the cost of replacement power during the outage, the impact of outage length on average capacity factor etc, this may not be the most economically efficient operation of the reactor core. Westinghouse states that the majority of its utility customers choose the 18-month fuel cycle.

567 The reference 18-month equilibrium cycle feeds and discharges 64 fuel assemblies every 18 months. On average, this means that approximately 43 assemblies per year are discharged and stored in the spent fuel pool. The cycle is based on an assumed 97 per cent capacity factor and a 21 day refuelling outage. This provides a cycle length of approximately 510 effective full power days. The 18-month reference cycle provides close to the lowest overall electrical production costs.

568 The fuel economics and the amount of spent fuel generated are closely correlated. Both are optimised when the fuel cycle is designed with the fuel being discharged from the reactor as close as is reasonable to the licensed discharge burn up of the fuel. The current licensed limit for Westinghouse fuel in the United States is 62,000 MWD/MTU on the lead rod maximum burn up. However, typically a batch average burn up around 50,000 MWD/MTU is achieved based on inter-assembly power variations and variations of assembly power in assemblies within the same batch.

12.2 BAT for fuel design

569 Fission products may diffuse from the fuel and pass through the fuel cladding through diffusion or from leaks into the reactor coolant.

570 The design of the fuel rod and the cladding for AP1000 is such that in the event of fuel clad defects, the high resistance of uranium dioxide (UO_2) to attack from water protects against fuel deterioration, although limited fuel erosion can occur. The consequences of defects in the clad are significantly reduced by the ability of uranium dioxide to retain fission products, including those which are gaseous or highly volatile.

571 Zirlo is an advanced zirconium based alloy which has a high corrosion resistance to coolant, fuel, and fission products. Selecting Zirlo cladding materials for the AP1000 minimises defects forming that can result in radioactive releases to the reactor coolant.

572 The BAT forms Westinghouse produced in its BAT assessment report consider tritium, which arises mainly from ternary fission of the uranium fuel followed by diffusion through the fuel pin cladding into the reactor coolant system (RCS). Westinghouse considers that this source of tritium is unavoidable in systems using uranium as a fuel. Using zirconium, zirlo cladding reduces diffusion of tritium compared with other cladding material options. Using reactor controls, including grey rod cluster assemblies, to minimise the need for changes to the concentration of soluble boron, and burnable poisons to limit the amount of boron required, are measures that help to minimise the amount of tritium produced in the reactor coolant. The main measures of reducing the formation of tritium relate to the quality of the fuel cladding and minimising fuel defects.

12.3 Management and disposal of spent fuel

573 After spent fuel is removed from the reactor, it will be stored in the spent fuel storage pool to allow radioactive decay to occur and decay heat to be removed. The spent fuel is transferred from the containment building to the spent fuel pool by the fuel transfer system. The fuel handling equipment is designed to handle the spent fuel assemblies underwater from the time they leave the reactor vessel until they are placed into the spent fuel storage pool and eventually in the container for dry storage or shipment from the site.

574 The spent fuel storage pool is located in the auxiliary building and provides storage for spent fuel in borated water with a nominal boron concentration of 2700ppm, to act as a neutron absorber. A spent fuel pool cooling system is provided to remove decay heat generated by the stored fuel assemblies from the water in the spent fuel pool. The decay heat is removed by pumping the high temperature water from within the fuel pool through a heat exchanger, and then returning the water to the pool. A purification system is part of the spent fuel and removes radioactive corrosion products, fission

- product ions, and dust to maintain low spent fuel pool activity levels during plant operation and to maintain water clarity during all modes.
- 575 Spent fuel is stored in high density racks which include integral neutron absorbing material to maintain sub-criticality. The racks are designed to store fuel of the maximum design basis enrichment. An assembly cannot be inserted into a location that is full and the design of the racks is such that a fuel assembly cannot be inserted into a location other than a location designed to receive an assembly. The pool contains three region one rack modules, five region two rack modules and five individual defective fuel assembly storage cells. Region 1 racks are used for storage for new fuel and freshly discharged fuel, and Region 2 racks for storage of less reactive fuel.
- 576 The spent fuel assemblies are usually stored in the pool for up to 18 years, which reduces fission product activity and decay heat generation. After this retention period, batches of assemblies are transferred to the HLW dry cask storage facility. Since spent fuel is not expected to be reprocessed, a facility for dry spent fuel storage is being offered to operators as part of the reference design.
- 577 Westinghouse has proposed the Holtec underground dry spent fuel storage system, the HI STORM 100U system. The spent fuel assemblies are transferred to the storage cask which is designed to shield radiation. The process of loading spent fuel is carried out in a number of steps. The cask handling crane is used to bring in a clean, empty cask to the cask washdown pit where it is washed with demineralised water. The cask lid is removed and stored while the remainder of the cask is washed. The clean empty cask is then properly positioned in the flooded cask loading pit.
- 578 The fuel handling machine is positioned over the specific fuel assembly to be exported out of the spent fuel storage rack. The fuel assembly is picked up and transported into the cask loading pit. During the transfer process the fuel assembly is always maintained with the top of the active fuel at least 2.9 m below the water surface. This ensures that the direct radiation at the surface of the water from the fuel is minimal.
- 579 Once the fuel transfer process is complete, the lid is placed on top of the cask to provide the required shielding. The cask is then moved to the washdown pit and cleaned with demineralised water. Decontamination procedures are implemented at this time. When the cask is satisfactorily decontaminated, the cask handling cranes is used to lift it out of the washdown pit in preparation for transfer to the HLW store. During these operations enough water is maintained between plant personnel and fuel assemblies that are being moved to limit dose levels to those acceptable for continuous occupational exposure.
- 580 The ERs 2.3.6 describes the radioactive waste stores and includes the interim store for spent fuel. The spent fuel store is a seismically qualified below ground storage facility including spent fuel flasks, flask loading equipment, suitable flask transportation vehicles and equipment and below ground storage cells. It will be located within the boundary of the nuclear licensed site and Westinghouse proposes to maintain the potential for extending the store in the future. The proposed location was chosen to minimise the transportation distances between the auxiliary building and the spent fuel store and to facilitate safe transfer of the waste.
- 581 The Holtec HI STORM 100U system is a vertical, ventilated dry spent fuel storage system. Westinghouse and Holtec have confirmed that Holtec equipment can fit in the areas of the AP1000 that need to be reached in order to transfer spent fuel from the spent fuel pool to the underground storage area. The system consists of three primary components:
- a) HI STORM 100U underground vertical ventilated module, VVM - this provides the storage for multi purpose canister (MPC) in a vertical configuration inside a below ground cylindrical cavity. The main function for the VVM is to provide the biological shield and cooling.

- b) multi purpose canister (MPC) – this contains the spent fuel assemblies - the MPCs are identical to those in use in a number of above ground dry spent fuel storage facilities in the USA. The UK Regulators have visited one such above-ground dry spent fuel storage installation as part of an inspection visit during GDA.
- c) Hi-TRAC transfer cask which holds the MPC during loading operations.
- 582 The spent fuel will remain within the HLW store for a determined period of time; at present Westinghouse has allowed up to 100 years. This will enable the heat generating capacity of the spent fuel assemblies to reduce sufficiently to meet the requirements for disposal to the geological disposal facility (GDF).
- 583 Westinghouse has obtained and provided a view from the Radioactive Waste Management Directorate (RWMD) of the Nuclear Decommissioning Authority (NDA) (as the UK authoritative source) on the disposability of its proposed arisings of spent fuel.
- 584 RWMD concluded that compared with legacy waste and existing spent fuel, no new issues arise that challenge the fundamental disposability of the wastes and spent fuel expected to arise from operation of the AP1000 (See Annex 5).
- 585 The disposal route for rod cluster control assemblies, RCCAs will need to be clarified. The RWMD assessment indicates that they will not represent a major addition to the overall inventory, and that they could be conditioned separately as ILW or disposed of with the rest of the fuel assembly.
- 586 The regulators required further information from Westinghouse on the volume and radionuclides/activity for waste, including rod cluster control assemblies (RCCAs), redundant irradiated control rods, neutron source assembly and poison rod assemblies, including evidence that they will be disposable. Westinghouse identified RCCAs include 53 assemblies which are replaced once every 20 years. Similarly, there are also 16 grey rod assemblies, which are replaced every 20 years when they become redundant. Both the RCCAs and grey rod assemblies are disposed within the spent fuel assemblies. There are 72 poison rod assemblies that are used in the first core only and then disposed of as waste. There are two primary and two secondary neutron source assemblies. The primary sources are used once during the first cycle then disposed of and the secondary source assemblies are replaced once every 20 years. Westinghouse proposes all for disposal with the spent fuel.
- 587 Westinghouse provided the regulators with a critique of the RWMD disposability assessment, and this is available on its website. The regulators requested Westinghouse to make a case for the disposability of spent fuel and ILW, which demonstrates the following:
- a) How the issues identified in its critique of RWMD's Disposability Assessment will be addressed.
 - b) How the issues in Appendix B of RWMD's Disposability Assessment will be addressed.
 - c) How they will manage any risks associated with these issues.
- 588 Whilst our views are presented in this consultation document, we note HSE is continuing to review this information in its Step 4 assessment. We will continue to work closely with HSE on this issue, and this work will inform our decision document.
- 589 We received Westinghouse's response on 1 March 2010. We note in particular that Westinghouse has consulted with potential operators of the AP1000 on when they would expect to address issues and we recognise that, in most cases, these issues will need to be addressed by future operators of AP1000s, rather than by Westinghouse. It might have been prudent to discuss the timing of resolution of these issues with RWMD, to check how the planned timing fits with its usual expectation for the Letter of Compliance (LoC) process.

- 590 In general, we consider the plans proposed by Westinghouse to address – or, more commonly, for future licensees to address – outstanding disposability issues to be adequate at this stage. We expect these plans to be periodically refined and updated in future to reflect developments.
- 591 We stress, however, that we expect to see well before any AP1000s begin operation some further information from Westinghouse on the properties of high burn-up spent fuel following long term storage (particularly in relation to the integrity of fuel and Instant Release Fractions (IRFs)). We recognise that detailed and definitive information may not be available until there is direct operational experience (e.g. for the Stage 2 LoC submission), but we expect much earlier than that to see evidence of sufficient progress to provide reasonable confidence that any issues are likely to be manageable.
- 592 We note that Westinghouse has produced a ‘RWMC Evidence Report’, intended to indicate where the information that will be needed for future Radioactive Waste Management Cases (RWMCs) will come from, and when. This document gives us some assurance at this stage that RWMCs can be compiled at relevant stages in the development of an AP1000 fleet, which is sufficient at this stage of the GDA process. We note, however, that the RWMC evidence report in its current form would not yet fully meet our expectations for the format and content of a RWMC.
- 593 The regulators requested information on encapsulation of the spent fuel since this was not considered by the RWMD assessment. Westinghouse responded with information, including an outline of the current option for encapsulation of AP1000 spent fuel for dry storage; a description of the spent fuel repackaging system as a way of demonstrating that the necessary technology exists for encapsulating fuel for the GDF; and information relating to the GDF proposed for Sweden which incorporates features expected for the UK GDF. Section 10 of the radioactive waste management case (RWMC) evidence report for HLW outlines the proposed conditioning and disposability options for spent fuel.
- 594 The regulators asked Westinghouse to provide information on the potential actinide content of solid, liquid and gaseous wastes arising from reasonably foreseeable events during the lifecycle of the AP1000. This included the potential for the fuel to contain tramp uranium, that is traces of uranium on the outside of the cladding left over from manufacture of the fuel, and potentially for fuel failure.
- 595 Westinghouse responded that actinide release to a waste stream is possible if there is a leak in one or more fuel rods. Westinghouse provided information to support low leakage rates from fuel rods for the robust fuel assembly type fuel. The AP1000 fuel design for UK is based on this robust fuel assembly, RFA fuel, which is an improvement on previous fuel designs in that vibrations in the assembly are reduced. Given the low leak rate from fuel rods there should be little actinide activity in the RCS.
- 596 Westinghouse provided information from its fuel manufacturing operations in the US. The smear monitoring carried out on the fuel rods confirmed that tramp uranium contamination is insignificant.
- 597 The regulators requested further information from Westinghouse in regard to disposability of spent fuel and ILW. With particular regard to Westinghouse’s critique of the RWMD disposability assessment, the regulators needed more detail from Westinghouse when considering the impact of the RWMD review on its plans for conditioning, storing and dispatching the waste to a repository (GDF). Westinghouse were asked to make a case for the disposability of spent fuel and ILW to ensure it can be stored, transported and disposed of, including a plan showing how and when these issues will be addressed.
- 598 The HSE has commissioned the National Nuclear Laboratory to carry out work to identify mechanisms that could lead to early failure of the fuel cladding or the fuel assembly during storage. This work will be reviewed in HSE’s Step 4 and the findings will be taken into account in our decision document.

599 HSE wrote to us in March 2010 in regard to its Step 4 assessment, including those aspects that could affect disposability of spent fuel. Regulatory observations have been raised by the regulators on long term storage and disposability of spent fuel as discussed in the preceding paragraphs. HSE through its Step 4 of GDA will continue to work with us to review the information supplied by Westinghouse as it finalises the information contained in its submissions on long-term storage and disposability.

12.4 BAT to minimise disposals of spent fuel

600 The Westinghouse BAT assessment report does not address HLW, namely spent fuel, in detail and refers out to the ER section 3.5.4.3. The BAT report includes information on zinc addition to reduce corrosion product transport to the fuel. There is also information on fuel rod burn up, operational cycle, and fuel rod cladding design in regard to minimising emissions at source.

601 The development of the AP1000 design over a 15 year period, including the predecessor AP600 design, involved a number of design decisions that relate to minimising waste and applying best available techniques, BAT.

602 One of these decisions was using zinc addition to reduce the potential for corrosion product transport to the fuel. The AP1000 design includes a chemical and volume control system (CVS) that incorporates a zinc addition sub-system to reduce the rate of corrosion and the release of corrosion products in the reactor coolant system (RCS), which has the potential to cause primary side stress corrosion cracking and crud induced power shift. Zinc addition also reduces the potential release of active corrosion products into the liquid radwaste system. The other benefit of zinc addition is the potential to reduce occupational radiation exposure. We note HSE has raised some concern about reliance on Zn for fuel protection.

603 The BAT decisions for the longer term interim fuel storage were based on whether to store the fuel wet or dry, also whether to store the fuel above or below ground. Fuel transfers are all carried out underwater. For longer term storage of the fuel in canisters, Westinghouse notes it is preferable to store fuel under an inert gas atmosphere to minimise the corrosion issues associated with long-term wet storage.

604 Westinghouse claims that underground storage has the advantage of providing greater levels of shielding and a more secure solution with respect to the potential for aircraft impact and other catastrophic events. The disadvantages relate to control of groundwater issues and flood risk. Westinghouse notes these issues will need to be considered at the site-specific design stage.

605 For the generic site, Westinghouse proposes a dry spent fuel storage system to be stored inside an underground cylindrical cavity.

606 Westinghouse has not provided information on any discharges from spent fuel storage. We would not expect discharges from interim spent fuel storage to be significant, and unless evidence is provided by Westinghouse to the contrary, we propose any discharges would be within the limits and levels proposed in Chapters 9 and 10 above.

12.5 Summary of our assessment of spent fuel

607 We addressed comments we received on spent fuel from the public involvement process relating to the AP1000 design by 4 January 2008 in our preliminary assessment report (Environment Agency 2008a). Public comments on this subject were received during our detailed assessment stage. One comment requested information about the type of spent fuel cask that would be used to transport spent fuel for processing or disposal. Westinghouse's response was that the exact model of the spent fuel cask to transport spent fuel for processing or disposal has not yet been chosen. It is stated, however, that the cask selected will meet the requirements of

IAEA and UK standards for design and construction. The cask chosen will have been shown to survive a sequence of four simulated accident conditions involving impact, puncture, fire and submersion in water. Both during and after the tests, the cask must contain the nuclear material, limit radiation doses to acceptable levels, and prevent a nuclear reaction.

608 Westinghouse's proposals for storage of spent fuel are based on current practice. Westinghouse states confidence in managing long-term storage on the basis of international experience gained in spent fuel storage, and on the development of dry storage systems where the spent fuel is kept in an inert sealed atmosphere. The regulators have requested further information about the proposed storage facilities to support the long-term safe storage of the spent fuel and to ensure the fuel does not degrade over the long storage period. This is the subject of RO AP1000-74 issued to Westinghouse in April 2010.

609 **We conclude that in its submission, Westinghouse describes how spent fuel will arise, be managed and disposed of throughout the facility's lifecycle. Westinghouse provides information on new fuel composition and characteristics, and proposed fuel burn up. Westinghouse considered operating strategies in regard to spent fuel generation, and quantities of spent fuel that will arise. Information is provided in the submission and supporting documents on short and long-term management proposals for spent fuel. Westinghouse has obtained a view from NDA RWMD on the disposability of the fuel and has provided its critique to the regulators.**

610 **Westinghouse provided detailed responses in regard to disposability in March 2010, and whilst our views are presented in this consultation document, we note HSE is reviewing this information in its Step 4 assessment. As noted above the regulators have asked for information in regard to long term storage. We will continue to work with HSE on this, and this work will inform our decision document. Therefore, our conclusion is subject to the potential GDA Issue:**

- a) **Disposability of spent fuel following longer term interim storage pending disposal.**

13 Monitoring of radioactive disposals

611 We did not conclude that the AP1000 utilises the best available techniques to measure and assess discharges and, therefore, we have identified the following other issue:

- a) The monitoring of gaseous, aqueous and solid discharges and disposals of radioactive waste (AP1000-OI08).

Question 8: Do you have any views or comments on our preliminary conclusions on monitoring of disposals of radioactive waste?

612 We expect the design to use the best available techniques to measure and assess discharges of radioactive waste to the environment. This will enable any operational AP1000 to:

- a) confirm that discharges are as predicted by the designer;
- b) assess compliance with limits;
- c) provide good quality data for dose assessments.

13.1 Monitoring of gaseous disposals

613 Measures for monitoring discharges are described in chapter 6 of the ER and in the document titled '*AP1000 Generic Design Measurement and Assessment of Discharges*' (see Annex 5).

614 For the main plant vent, monitoring will be carried out for: particulates, iodine and noble gases, using continuous sampling and an isokinetic sampling nozzle. Grab samples can also be taken for laboratory analysis. The key radionuclides for the monitoring of aerial discharges were identified as tritium, carbon-14, krypton-85 and iodine-131 and other particulate (for example, cobalt-60 and caesium-137). The proposed limits of detection will not meet those required by EU Commission Recommendation 2004/2/Euratom for iodine-131, strontium-90 and caesium-137.

615 Monitoring of tritium and carbon-14 will be required and Westinghouse stated in ER section 6.2.1.1 that a bubbler system for sampling tritium and carbon-14 will be incorporated into the design of the main stack monitoring system.

616 Westinghouse carried out a review against M11 (Environment Agency 1999a) requirements with broad consistency being claimed, and with reference to American National Standard (ANSI N13.1), although evidence was not provided. It stated that some of the differences were to be addressed at future stages of the design and authorisation process.

617 No formal BAT assessment was carried out when considering the monitoring options.

618 The design of the stack monitoring system is still being developed and the equipment specifications have not been completed. When the instrument to be used for flow rate measurement has been specified, Westinghouse states in ER section 6.2.1.1 that it will review the MCERTS register to see if a suitable instrument is available. Information on monitoring and flow measurement points and upstream and downstream disturbances and the location of filtration have not yet been determined.

619 The design of the area surrounding the monitoring locations is still being developed, but Westinghouse states in ER section 6.2.1.1 that industry codes and standards along with M1 (Environment Agency 2010a) will be considered.

620 Westinghouse states in ER section 6.2.1.2 that the AP1000 will have on site laboratory facilities, but specification of equipment and implementation of processes necessary to gain accreditation to ISO 17025 (BSI 2005) is operator specific.

621 We have assessed the information Westinghouse provided on the AP1000 design for determining gaseous discharges against the requirements of M1 (Environment Agency 2010a) and M11 (Environment Agency 1999a) and other best practice for monitoring.

622 **We have concluded that:**

- a) **No formal BAT assessment has been undertaken for the monitoring of gaseous disposals.**
- b) **The single sampling point for gaseous disposals does not allow the requirement for independent sampling to be satisfactorily met.**
- c) **Not enough information has been provided on the location of the monitoring and flow measurement points, and evidence has not been provided to back up statements about how representative samples would be achieved. Therefore, we cannot assess appropriateness of monitoring of gaseous disposals at this stage.**
- d) **We could not make an assessment on the suitability of the sampling lines. The information is pointing to them being too long as they descend from the sampling points in the stack to the monitoring equipment in the auxiliary building.**

13.2 Monitoring of liquid disposals

623 Measures for monitoring discharges are described in chapter 6 of the ER and in the document titled '*AP1000 Generic Design Measurement and Assessment of Discharges*' (see Annex 5).

624 There are three discharge streams for liquid radioactive effluents: the liquid radwaste; waste water; and service water systems. The latter two could contain low levels of radionuclides and are minor discharge routes under normal conditions. All three streams are released through the same pipeline. For the liquid radwaste stream, there will be continuous online monitoring for caesium-137 in the discharge pipe. Additionally, samples from the discharge tank will be collected and analysed before discharge. Westinghouse has similar arrangements for the minor streams. Westinghouse states that the key nuclides for monitoring are tritium and a fission product, for example caesium-137, but it only intends to monitor for caesium-137 and its limit of detection (LoD) for this meets the EU Commission (Euratom 2004/2/) required value. Westinghouse states that it could determine the other EU Commission recommended radionuclides tritium, cobalt-60 and strontium-90 by grab samples if required.

625 Westinghouse states that it broadly conforms to the objectives and principles in M12 (Environment Agency 1999b), with some of the differences expected to be addressed at future stages of the design and licensing process.

626 No formal BAT assessment was carried out when considering the monitoring options.

627 Westinghouse states in ER section 6.2.1.2 that the instrument for flow rate measurement has not been specified, but when it has, Westinghouse states that it will review the MCERTS register to see if a suitable instrument is available.

628 Westinghouse has indicated in ER section 6.2.1.2 that the design will be able to accommodate both grab sampling as well as proportional sampling to obtain a representative sample (including provision for separate proportional samplers that can be secured to provide independent measurement) on the discharge lines.

- 629 There are requirements for sampling and monitoring equipment to be protected from the weather and interference by unauthorised personnel and for analysis to achieve ISO17025 and MCERTS accreditation. Westinghouse states in ER section 6.2.1.2 that all sampling and monitoring equipment will be housed in weather shielded buildings and will be located in areas where access is controlled. It also stated that there will be an on site laboratory with the capability to be UKAS accredited to ISO17025, but pointed out these would be operator responsibilities.
- 630 We have assessed the information Westinghouse has provided on the AP1000 design for determining aqueous discharges against the requirements of M12 (Environment Agency 1999b) and other best practice for monitoring.
- 631 **We have concluded that no formal BAT assessment has been carried out for monitoring liquid disposals.**

13.3 Monitoring of solid waste disposals

- 632 Westinghouse has provided limited information on the monitoring of solid waste disposals, which appears in line with current practice.

14 Impact of radioactive discharges

- 633 We have assessed the information Westinghouse provided for the AP1000 relating to the impact on members of the public and non-humans as a result of the disposal of aqueous and gaseous radioactive waste by discharging it to the environment.
- 634 We conclude that Westinghouse's generic site parameters and its values, which define its generic site, are appropriate to use in its assessment of radiological impact at the GDA stage.
- 635 We conclude that Westinghouse has made an adequate assessment of the impact of the discharges which assumes the AP1000 is located at a coastal location. The estimates of dose to members of the public are well below the UK constraint for any single new source of $300 \mu\text{Sv y}^{-1}$ and also below the dose constraint proposed by the Health Protection Agency (HPA, 2009) that recommends that the UK Government select a value for the constraint for members of the public from new nuclear power stations to be below $150 \mu\text{Sv y}^{-1}$. We also conclude that the discharges would not adversely affect the integrity of any conservation sites.
- 636 In its assessment of the impact on members of the public Westinghouse carried out a single stage of assessment. Its assessment consisted of a refined assessment at stage 2 using our initial radiological assessment system. This was carried out twice; once for representative discharges and once for its proposed limits – which are higher than the representative discharges. Its estimate of doses was $14 \mu\text{Sv y}^{-1}$ for its representative discharges. This dose was from the operation of a single AP1000, with discharges at the annual limits specified above. We were able to verify all stages of the assessment produced by Westinghouse.
- 637 Westinghouse's estimate of dose is well below the UK constraint for any single new source of $300 \mu\text{Sv y}^{-1}$, and is also below the dose constraint proposed by the Health Protection Agency (HPA 2009) that the UK Government select a value for the constraint for members of the public from new nuclear power stations to be below $150 \mu\text{Sv y}^{-1}$. On the basis of this relatively low dose, Westinghouse did not carry out a more detailed stage 3 assessment.
- 638 We made two assessments of dose; a stage 2 assessment to verify the Westinghouse assessment and a more detailed stage 3 assessment. Our assessment of the doses from the AP1000 was $14 \mu\text{Sv y}^{-1}$ for stage 2 and $8 \mu\text{Sv y}^{-1}$ for stage 3.
- 639 Westinghouse assessed the dose to plants and animals near an operating AP1000. It predicts the highest dose rate to be:
- a) no risk for the most sensitive combination of terrestrial animals;
 - b) $25.2 \mu\text{Gy h}^{-1}$ for a marine organism (polychaete worm).
- 640 We have also made an assessment of radiation dose rates to plants and animals near an operating AP1000. We predict the highest dose rates to be:
- a) $0.1 \mu\text{Gy h}^{-1}$ for a terrestrial organism (a bird egg);
 - b) $0.04 \mu\text{Gy h}^{-1}$ for a marine organism (a mammal).
- 641 These dose-rates are well below $40 \mu\text{Gy h}^{-1}$, which is the value below which we consider that there will be no adverse effect on the integrity of a conservation site (Environment Agency, 2009d).

Question 9: Do you have any views or comments on our preliminary conclusions on the impact of radioactive discharges?

14.1 Verification of assessments of impact

642 Westinghouse has made an assessment of the impact of the discharges of radioactivity from the AP1000 to the environment. We have reviewed its assessment in detail. Our review involved two main processes. Our first process was verifying the assessment Westinghouse provided. The verification aimed to reproduce the impacts Westinghouse assessed, adopting its model and input data. Our second process was to carry out our own assessment of the impacts using best practice and recommended models and assumptions. These are summarised in Table 14.1 below. We also compared the outputs and approach from our own assessment with those of Westinghouse. We followed up any significant discrepancies with Westinghouse, where appropriate. These processes helped us to be sure that the assessment of impacts on people and the environment were correct and valid.

Table 14.1 summary of assessment outputs from the Westinghouse assessment of the AP1000 and our verification for representative annual discharges

Assessment	Westinghouse calculated dose $\mu\text{Sv y}^{-1}$	Verification of Westinghouse assessment	Our calculated dose using our assumptions $\mu\text{Sv y}^{-1}$
Stage 1	N/A	-	N/A
Stage 2	14+	V	14+
Stage 3	N/A	-	8+
Short duration release to atmosphere	12**	VC	12**

*Dose to the representative person including direct radiation
 +Sum of doses to the groups most exposed to gaseous and liquid discharges and direct radiation
 ** units are μSv
 V – verified – able to reproduce their assessment exactly
 VC – validated by comparison between our assessment and AP1000.

14.2 Generic site concept

643 At present, there are no specific sites for which detailed site-specific assessment can be made. At the generic design assessment stage, ahead of an application to build and operate an AP1000 at a particular site, we have requested an assessment to inform us about the potential impact from an operating AP1000. This assessment is based on available information on the design. We have also carried out our own assessment of what the impact could be. To make sure that the assessment is realistic, we have asked Westinghouse to consider a ‘generic site’. The characteristics of the generic site should be appropriate to sites in the UK where nuclear power stations might be built and will define the ‘envelope’ of applicability of any statement of design acceptability that we might issue.

644 We have asked Westinghouse to identify the key factors that will affect the doses received and take them into account when establishing the characteristics of the generic site. The key characteristics that are of interest to us include:

- a) weather and other parameters affecting gaseous dispersion and deposition;
- b) hydrographic and other parameters affecting aqueous dispersion;
- c) location of nearest food production, how close people might reasonably live to the site, the location of sensitive habitats and species;
- d) food consumption rates and other human habits data.

645 Westinghouse has derived its AP1000 generic site characteristics based on information from five coastal nuclear power stations around the UK. The five power stations are Dungeness, Hartlepool, Heysham, Hinkley and Sizewell. Westinghouse considers these sites to be typical of the range of nuclear coastal sites in the UK. Westinghouse has also obtained information from the Government's on-line geographical information system. (ER c5.1)

14.2.1 Westinghouse generic site characteristics and exposed groups

646 Westinghouse's AP1000 generic site characteristics include data on:

- a) **Human population** – Westinghouse has analysed the centres of population within 20km of the five power station sites and has assumed that the generic site has the 80th percentile number of population centres within a given distance. It has derived the number of population centres with a population of more than 100,000, more than 20,000, more than 5000, more than 1000, equal to or less than 1000 and farms and properties at distances of less than 1km, less than 2km, less than 10km and less than 20km from the generic site. For each size of population, it has identified the closest distance that a population of such a size is to the generic site. Westinghouse chose to use the 80th percentile number of population centres within a given distance as they consider that this gives a conservative yet realistic generic site. (ER Table 5.1-1)
- b) **Exposed population groups** – for dose assessment purposes Westinghouse has considered two exposure groups for human population:
 - i) The locally resident farming family selected to represent exposure pathways associated with atmospheric releases from the AP1000. The local resident family comprises infants, children and adults who live 100m from the aerial discharge point. They spend most of their time at home, some of which is spent outdoors. They eat food from local sources and milk from local farms which are 500m from the aerial discharge point. They eat locally caught fish and shellfish.
 - ii) The fisherman family selected to represent the exposure pathways associated with discharges from the AP1000 to the coastal environment. The fisherman and his family are assumed to spend time on intertidal sediments in the area and consume high levels of locally caught fish and shellfish as well as smaller amounts of locally produced fruit and vegetables from local sources up to 500m from the aerial discharge point. This group live far enough from the site not to be exposed to direct radiation from atmospheric releases.
- c) **Habits data** – which includes things such as food consumption rates, breathing rates and occupancy rates for three age groups (1 year old infant, 10 year old child and adult). At existing nuclear sites we have collected habits data to use in our impact assessments. However, for the generic sites, where no site-specific data is available, generic habits data can be used. This data is used to define habits for the exposure groups considered in the assessment. Generic habit data derived from UK national surveys is published in recognised sources such as NRPB-W41. (ER Tables 5.1.2 and 5.1.3). Generic habits normally lead to greater exposure than site-specific habits, resulting in higher predicted doses than may be expected for a site-specific assessment.
- d) **Meteorology** – Meteorological data has been derived for the generic site from worst-case maximum, worst-case minimum and average data for the five power station sites. Data on atmospheric conditions and atmospheric deposition coefficients have been used which are consistent with data published in recognised sources such as our Initial Radiological Assessment Methodology and IAEA SR19. (ER Table 5.1.5 and 5.1.6.)

- e) **Terrestrial environment** – it has been assumed that the highest elevation within 2km of the generic site is 30m high and within 10km is 358m high. Land cover around the generic site is generally assumed to be arable, grassland, dunes and some woodland. A surface roughness of 0.3m has been assumed which is typical of a rural location. It is assumed the land is stable with few geological faults and the geology is glacial clay with sand and gravel lenses. Perched groundwater is assumed to be 2m below the surface and the generic site overlies a major aquifer with a groundwater level 20m below the surface. Based on British Geological Survey data it has been assumed that the generic site has the potential to experience an earthquake of 6.5 magnitude on the Richter scale. A number of sensitive or designated sites are assumed to be present near the generic site, the nearest being a Site of Special Scientific Interest, which is 180m from the generic site. (ER table 5.1.7, 5.1.8 5.1.9, 5.1.10).
- f) **Coastal environment** – tidal ranges have been assumed to be between -0.06m and 11.17m. The volumetric flow rate has been assumed to be $130 \text{ m}^3\text{s}^{-1}$, which is the most conservative exchange rate associated with the five power station sites. Sand, gravel, rock, mud and made ground (or combinations of these substrates) which are found at the five power station sites are assumed to be present in the inter-tidal zone. The bathymetry assumed for the generic site assumes water depth in terms of Admiralty Chart Datum to range from -15m to 5m over a distance of 10km from the generic site. A range of marine biological features such as water and wildfowl areas, sensitive fish areas and seabird nesting colonies are assumed to be present within 10km of the generic site. (ER table 5.1.11, 5.1.12, 5.1.13)

647 **Non-human species** – It is assumed that European and UK protected species may be present including birds, terrestrial mammals, reptiles and amphibians, marine mammals and fish, invertebrates and flora. Westinghouse has assumed that all reference organisms specified in the ERICA integrated approach are present. Using reference organisms with defined anatomical and physiological properties and habits to represent typical organisms in the ecosystem is an accepted practice in assessing the impact on non-human species. Westinghouse has assumed the terrestrial organisms to be located at the site boundary and the marine organisms to be 150m from the discharge point. (ER Table 5.1.4)

648 Westinghouse has used the AP1000 generic site characteristics in its assessment of the potential radiological impact of the AP1000 on members of the public and non-human species.

14.2.2 Our view of the Westinghouse generic site characteristics

649 We have reviewed the Westinghouse generic site characteristics. We believe that they are justified and reasonable and represent a conservative approach, while also being realistic. We consider the parameters and its values that define its generic site are appropriate to use in its assessment of radiological impact at the GDA stage. We recognise that a detailed site-specific assessment of the radiological impact from the AP1000 will be required for any site where the AP1000 is proposed and, therefore, site-specific data will be required for any site at which an AP1000 reactor may be located.

650 **We conclude that Westinghouse's generic site parameters and its values, which define its generic site, are appropriate to use in its assessment of radiological impact at the GDA stage.**

14.3 Our requirements for the assessment of doses to people

651 We have required Westinghouse to make an assessment of doses to the representative person. This assessment should use the generic site characteristics, together with agreed or expected levels of discharges, and suitable models to predict the behaviour and concentrations of radionuclides in the environment once they have

been discharged. We require allowance for build up in the environment from discharges continuing for 50 years. A reference modelling system for carrying out stage 2 assessment is the Environment Agency's initial assessment system. If doses are assessed as above $20 \mu\text{Sv y}^{-1}$; a more detailed assessment may be required. A more detailed assessment (called stage 3) can be carried out using the EC system described in an EC publication number RP-72 and implemented by the HPA in a computer code PC CREAM 98. Westinghouse has carried out a stage 2 assessment, but has not moved to a stage 3 because the doses are less than $20 \mu\text{Sv y}^{-1}$.

652 Doses to members of the public are calculated taking account of the predicted levels of radionuclides in the environment and the habits of members of the public near the site. Those members of the public who are estimated to receive the highest dose overall (from gaseous and aqueous discharges and direct radiation) are described as the 'representative person'. The dose to the representative person is then compared with the dose constraint and dose limit. Doses to members of the public from direct radiation originating from within the site boundary are regulated by HSE. However, for the purposes of comparing doses to the dose constraint, we have estimated doses from direct radiation based on data from Sizewell B in 2007. (Environment Agency, et al, 2008b). HSE will be making an assessment of direct radiation dose as part of its work in Step 4.

653 The assessment approach is designed to make sure that provided the dose to the representative person is below these dose criteria, doses to the public near the site will also be less than the dose criteria. We may also consider doses from liquid discharges or gaseous discharges separately. Where a separate assessment is made for different types of discharges, the term 'representative person most exposed to' is used. Doses from the separate assessments may be added together to provide an estimate of total dose from the reactor. However, this addition is likely to lead to an over-estimate of dose. This is because it is unlikely that any person would have both sets of habits that would lead to most exposure to various types of discharges at the same time. Therefore, the dose to the representative person is calculated using a method that makes realistic combinations of exposures and habits.

654 Westinghouse provides information on its assessment of doses to the public in its submission.

14.3.1 Westinghouse assessment approach

655 Westinghouse carried out a one-staged approach to its assessment. It began in the second stages from our initial radiological assessment methodology (Environment Agency, 2006), which allows a conservative assessment of doses to members of the public from discharges of gaseous and liquid radioactive waste.

- a) Stage 1 is normally a conservative or bounding assessment that can be used as a screening assessment to identify if a more detailed dose assessment is required. Westinghouse did not submit a stage 1 assessment.
- b) Stage 2 is a more refined assessment using more realistic key parameters such as stack height and liquid dispersion factors. Westinghouse used our published dose per unit release factors in a more realistic way. For gaseous discharges, the effective release height was assumed to be 22.5m, which Westinghouse considers to be realistic. This takes into account the physical heights of the release point and building wake effects. A high release height allows more dispersion and results in lower concentrations at ground level. An effective release height of ground level is likely to lead to the highest estimates of dose. For liquid radioactive waste discharges, a key function is dispersion, which is controlled by the amount of water flowing past the release point and exchanging with water around the site. Relatively low exchange rates can lead to higher dose estimates. For liquid discharges, the volumetric exchange rate along the coast was taken to be $130 \text{ m}^3\text{s}^{-1}$. This is the lowest exchange rate (worst case) at five locations around England

and Wales chosen by Westinghouse to represent sites where a new AP1000 reactor might potentially be located. Westinghouse made two stage 2 assessments; one using the representative annual discharges from the reactor and one using their proposed discharge limits.

656 Our initial radiological methodology calculates doses to the most exposed members of the public for gaseous and liquid radioactive waste discharges. Doses to the most exposed members of the public were calculated for three age groups (infant, child and adult) for each radionuclide in the discharge. The doses to the age group which resulted in the highest dose to the most exposed member of the public for each radionuclide have been used to calculate the total dose to the most exposed members of the public.

657 Westinghouse also estimated doses from direct radiation from the AP1000 in order to predict the dose to the representative person.

658 Stage 3 is a more detailed assessment and is usually carried out where stage 2 outputs are above 20 $\mu\text{Sv y}^{-1}$. A stage 3 assessment may also be carried out where doses are lower than this and additional assurances or more detail is needed about predicted doses. Westinghouse did not carry out a stage 3 assessment.

659 We considered the approach and assumptions made by Westinghouse in its stage 2 dose assessment to be reasonable.

14.3.2 Westinghouse’s assessment results

660 Table 14.2 shows the doses Westinghouse predicted.

Table 14.2 Westinghouse predicted doses for the AP1000 design for representative annual discharges.

Pathway	Doses to the public $\mu\text{Sv y}^{-1}$	
	Stage 2	Stage 3
Liquid discharges	2	N/A
Gaseous discharges	8	N/A
Direct radiation	4	N/A
Total dose	14	N/A
Short duration release to atmosphere+	N/A	12+**

+Assuming 1 month’s worth of discharge occurs over 30 minutes. ** units are μSv

661 Westinghouse’s stage 2 assessment resulted in estimated doses to the representative person of the public of 14 $\mu\text{Sv y}^{-1}$ (ER Table 14.2).

662 The highest contribution to dose was from consuming carbon-14 in milk resulting from gaseous discharges.

663 From time to time, processes on site may result in additional discharges to atmosphere. These include de-fuelling and coolant purges. The discharges can range from 30 minutes to several hours. Westinghouse has made an assessment of a short duration release – assuming one month’s discharge is released over 30 minutes. This results in an estimated dose from a short duration release from an AP1000 to the representative person of 12 μSv

664 **We conclude that all the doses Westinghouse assessed are below the dose constraint for members of the public of 300 $\mu\text{Sv y}^{-1}$ and the dose constraint recommended by HPA for new build of 150 $\mu\text{Sv y}^{-1}$.**

14.3.3 Our verification of the Westinghouse assessment results

665 We were able to repeat the stage 2 assessment of the Westinghouse dose assessment except initially for doses due to short duration releases. As a result of our verification exercise, Westinghouse reviewed its assessment of the dose due to short duration release from an AP1000 and provided a revised estimate of 12 μSv .

666 We have also carried out our own more detailed (stage 3) dose assessment, assuming discharges are made at the proposed limits. For this, we used the PC CREAM 98 model and standards practices used by the Environment Agency for regulation under RSA93.

667 Our stage 3 assessment showed the highest estimated doses from an AP1000 is to an infant representative person of 11 $\mu\text{Sv y}^{-1}$, who is most exposed to gaseous discharges (Table 14.3). This assessment outcome is for our proposed annual limits on discharges for the AP1000.

668 The highest doses are from gaseous discharges and the highest contribution was from carbon-14 in milk.

Table 14.3 Summary of our assessed doses to representative person at stage 3 from the AP1000 design at representative annual discharges and our proposed limits.

Pathway	Doses to the public $\mu\text{Sv y}^{-1}$	
	Representative annual discharges	Our proposed limits
Liquid discharges	<1	<1
Gaseous discharges	4	7
Direct radiation	4	4
Total dose	8	11

14.4 Source dose constraint

669 There is a dose constraint (Defra, 2000) for the maximum dose to people that may result from discharges from a new single source (for example, a new power station). The constraint is 300 $\mu\text{Sv y}^{-1}$ and it applies to the dose from proposed discharges and direct radiation.

670 As set out above, our assessment shows that, for the AP1000, the sum of doses to the representative person from representative annual discharges and direct radiation is 8 $\mu\text{Sv y}^{-1}$ and is below the source dose constraint. At our proposed limits, the sum of doses to the representative person is 11 $\mu\text{Sv y}^{-1}$, which is also below the source dose constraint.

671 **We conclude that the sum of doses to the representative person is below the source dose constraint.**

14.5 Site dose constraint

672 There is also a dose constraint (Defra 2000) for the maximum dose to people that may result from discharges from a site as a whole. The constraint is 500 $\mu\text{Sv y}^{-1}$ and it applies to the total dose from the discharges (direct radiation is not included) from all sources at a single location, including discharges from immediately adjacent sites.

673 A number of the sites listed in the nuclear national policy statement (DECC 2009b) as potentially suitable for a new nuclear power station are adjacent to existing nuclear power stations. In GDA, the specific site at which an AP1000 might be located is not known, but we consider, in the light of our assessment, that the highest total dose is estimated to be $11 \mu\text{Sv y}^{-1}$. It is very unlikely that doses at the site will exceed the site dose constraint of $500 \mu\text{Sv y}^{-1}$. We consider that site dose should be assessed at the site-specific stage.

674 **We conclude that site dose should be assessed at site-specific permitting.**

14.6 Dose limit

675 There is also a dose limit (Defra 2000) for the maximum dose to any member of the public from ionising radiation. The dose limit is 1 mSv y^{-1} ($1000 \mu\text{Sv y}^{-1}$) and it applies to the total dose from all artificial sources including past discharges, but excluding medical and accidental exposure.

676 Comparison against the dose limit can only be done at site-specific permitting when contributions from all sources of radiation can be included.

14.7 Doses to people – collective dose

677 Collective dose is sometimes used as a measure of the radiation detriment to a population. It is the sum of all the doses received by the members of a population over a specified period of time. Collective doses are measured in man-sieverts (manSv). There are no limits or constraints for collective dose. However, the International Atomic Energy Agency (IAEA) has set a level for collective doses of less than 1 manSv per year of discharge as part of its criteria for discharges not requiring regulatory control.

678 The UK Health Protection Agency, Radiation Protection Division (HPA-RPD), has provided additional guidance on assessing how important the collective doses are. It advises calculating an average dose to members of the population (per person doses). HPA-RPD advised that if the average per person doses for a population group are only a few nano-sieverts (nSv) per year, we can consider them to be less important. If the per person doses increase above this level, we need to look more carefully at the discharge options.

679 Westinghouse has provided Information on collective dose.

680 Westinghouse has estimated collective dose at the representative annual discharges to UK, Europe and world populations truncated at 500 years using PC CREAM 98. Table 14.4 shows the results of Westinghouse's collective dose assessment.

Table 14.4 Collective doses estimated by Westinghouse from discharges from AP1000 at representative annual discharges

Population	Collective dose manSv y ⁻¹	Per person dose nSv y ⁻¹
UK	0.27	4.9
Europe	2.1	3
World	13	1.3

681 Westinghouse considers that the collective dose to all populations is dominated by releases of carbon-14 in gaseous radioactive waste.

682 We have also carried out our own calculations of collective dose. We did this for the UK, European and world populations over the next 500 years, assuming discharges are made at the representative annual discharges of liquid and gaseous radioactive waste. We used the PC CREAM 98 software to estimate collective dose. Our results are set out in table 14.5 below.

Table 14.5 Our estimate of collective doses from discharges from AP1000 at the representative annual discharges

Population	Collective dose manSv y ⁻¹	Per person dose nSv y ⁻¹
UK	0.26	4.7
Europe	2.1	2.8
World	13	1.2

683 Comparing our assessment of collective dose and the assessment Westinghouse carried out shows almost identical results. Our assessment of collective dose similarly showed collective dose to be dominated by contributions from carbon-14 in discharges of gaseous radioactive waste.

684 For comparison, the annual collective dose to the UK population from background radiation has been calculated as 130,000 manSv (HPA, 2005). The collective dose from the AP1000 is above the IAEA level of 1 manSv per year of discharges, indicating that the discharges should be regulated. As the average per person doses are low, we consider that additional measures to minimise discharges are not required to control collective doses.

14.8 Doses to other species

685 We need to know the likely impact of the proposed discharges on non-human species to show that they will be adequately protected and that relevant conservation legislation will be complied with. In a similar way to the assessment of doses to humans, models of the behaviour and transfer of radionuclides within ecosystems are used to predict environmental concentrations, from which the radiation doses to reference organisms can be estimated. These doses can then be compared to 'guideline values' to assess the level of risk to flora and fauna. As described in our considerations document (Environment Agency, 2009c), we have adopted a value of 40 µGy h⁻¹ as the level below which no further regulatory attention is warranted.

- 686 Westinghouse has provided information on assessment of doses to non-human species (ER Chapter 5.3). Its approach to assessing the impact on non-human species is summarised below:
- a) Westinghouse predicted the expected discharges of radionuclides in aqueous and gaseous radioactive waste that are likely to occur from its AP1000 design. It has used this data to assess the potential impact of the discharges to non-human species.
 - b) In its assessment, Westinghouse used the ERICA (Environmental Risk from Ionising Contaminants: Assessment and Management) integrated approach (Beresford, 2007), which is the accepted practice within the European Union. The ERICA integrated approach aims to ensure that decisions on environmental issues give appropriate weight to the environmental exposure, effects and risks from ionising radiation, with emphasis on ensuring the structure and function of ecosystems.
 - c) To carry out the assessment, Westinghouse used the ERICA tool, which is a software programme that calculates the radiation dose rate that a reference organism is likely to receive from a defined activity concentration of a radionuclide. Reference organisms are used because, given the variation between species, it is not generally possible to develop species-specific assessment systems (as has been done for human radiation protection). Westinghouse has assumed that all reference organisms specified in ERICA are present and has included reference organisms that it considers are typical or representative of terrestrial and marine ecosystems.
- 687 The ERICA integrated approach has a default screening criterion for all ecosystems or organisms which is an incremental dose rate of $10 \mu\text{Gy h}^{-1}$ below which 95 per cent of all species should be protected from ionising radiation (Andersson, 2009).
- 688 The ERICA Integrated Approach takes a tiered approach that allows progressively more detailed assessment depending on the magnitude of the dose rates calculated:
- a) Tier 1 is simple and conservative – it requires a minimal amount of input data, the user can select from a range radionuclides and calculate the dose rate for the most sensitive combination of reference organisms.
 - b) Tier 2 is more specific and less conservative – the user defines the radionuclides of interest and edits transfer parameters. Dose rates are calculated for each reference organism individually.
 - c) Tier 3 is very specific and detailed – used in complex and unique situations and involving a probabilistic risk assessment approach. A tier 3 assessment requires consideration of biological effects data.
- 689 Westinghouse used the following parameters in its assessment:
- a) The expected annual discharges of radionuclides to air and water were used to derive activity concentrations in sea water, sea bed sediments, air and soil using the IAEA SRS-19 model within the ERICA software code.
 - b) Default ERICA values for transfer parameters.
- 690 The ERICA tool does not allow the consideration of the impact of radioactive noble gases that may be discharged. Westinghouse used the R&D 128 method (Environment Agency 2003) for the assessment of the impact of radioactive noble gases on non-human species.
- 691 Westinghouse carried out its assessment of the impact of aerial releases on non-human species at tier 1 and its assessment of the impact of liquid releases at tiers 1 and 2. It considered the risk to terrestrial reference organisms from the predicted gaseous discharges and to marine reference organisms from the predicted liquid discharges.

692 The results of the Westinghouse assessment:

- a) identified that, for the most sensitive combination of reference organisms, the probability of the expected discharges exceeding the screening dose rate of $10 \mu\text{Gy h}^{-1}$ is less than one per cent. (ER c5.3.1 section 5.3.1.1)
- b) for marine organisms at tier 1, the dose rate for the most sensitive combination of reference organisms exceeded the screening dose rate, and therefore an assessment was carried out at tier 2. The results at tier 2 show that the predicted dose rates exceeded the screening dose rate of $10 \mu\text{Gy h}^{-1}$ for the reference organisms polychaete worm, macroalgae, sea anemone/true coral polyp and colony, benthic mollusc, vascular plant, benthic fish and crustacean. The maximum predicted dose rate was $25.2 \mu\text{Gy h}^{-1}$ for the polychaete worm. (ER c5.3.1 section 5.3.1.2)
- c) The greatest radiological impact to non-human species from atmospheric discharges is from carbon-14. The radiological impact from marine discharges is generally greatest from iron-55 or iron-59, particularly for the reference organism that inhabit the sediment or sediment water interface.

693 To assess the risks from noble gases, Westinghouse used the R&D 128 approach, using activity concentrations derived from the gaseous releases and the emission flow rate using the IAEA SRS-19 model. The assessment shows the highest total dose rate to fungi to be $0.00029 \mu\text{Gy h}^{-1}$ which is well below the ERICA screening dose rate of $10 \mu\text{Gy h}^{-1}$.

694 We carried out two evaluations of the assessment Westinghouse carried out using the ERICA tool and the R&D128.

- a) A validation exercise to satisfy ourselves that the results of the Westinghouse assessment were reproducible.
- b) An independent assessment at tier 2 to determine the dose rates using discharge data Westinghouse provided and predicted activity concentrations modelled for us by an independent contractor.

695 We were able to reproduce the results of the assessment Westinghouse carried out using the ERICA model when we used its input parameters.

696 Our assessment identified that, for each reference organism, the probability of the predicted discharges exceeding the screening dose rate of $10 \mu\text{Gy h}^{-1}$ is less than one per cent. The highest predicted dose rate for a terrestrial organism was calculated to be $0.1 \mu\text{Gy h}^{-1}$ for a bird egg and for a marine organism to be $0.04 \mu\text{Gy h}^{-1}$ for a mammal.

697 We were able to reproduce the results of the assessment Westinghouse carried out using the R&D 128 approach when we used its input parameters.

698 To assess the risks from noble gases, we used the R&D128 approach. We used our calculated predicted activity concentrations and calculated the highest predicted dose rate to be $0.00004 \mu\text{Gy h}^{-1}$ for a caterpillar which is well below the ERICA screening dose rate of $10 \mu\text{Gy h}^{-1}$.

699

A summary of the outcomes of a comparison of the Westinghouse assessment with our assessments is set out below:

Assessment type	Data source	Westinghouse results	Our results
Terrestrial			
ERICA tier 1	Westinghouse	No risk for most sensitive combination of reference organisms	No risk for most sensitive combination of reference organisms
ERICA tier 2	Independent	-	No risk for any individual reference organism. Maximum predicted dose rate is 0.1 $\mu\text{Gy h}^{-1}$ for a bird egg
R&D 128	Westinghouse	Maximum predicted dose rate is 0.0003 $\mu\text{Gy h}^{-1}$ for fungi	Maximum predicted dose rate is 0.0003 $\mu\text{Gy h}^{-1}$ for fungi
	Independent	-	Maximum predicted dose rate is 0.00004 $\mu\text{Gy h}^{-1}$ for caterpillar
Marine			
ERICA tier 1	Westinghouse	Maximum predicted dose rate for most sensitive combination of reference organisms is greater than 10 $\mu\text{Gy h}^{-1}$	Maximum predicted dose rate for most sensitive combination of reference organisms is greater than 10 $\mu\text{Gy h}^{-1}$
ERICA tier 2	Westinghouse	The predicted dose rates exceed the screening value of 10 $\mu\text{Gy h}^{-1}$ for 9 reference organisms. The maximum predicted dose rate is 25 $\mu\text{Gy h}^{-1}$ for polychaete worm	The predicted dose rates exceed the screening value of 10 $\mu\text{Gy h}^{-1}$ for 9 reference organisms. The maximum predicted dose rate is 25 $\mu\text{Gy h}^{-1}$ for polychaete worm
	Independent	-	No risk for any individual reference organism. Maximum predicted dose rate is 0.04 $\mu\text{Gy h}^{-1}$ for a mammal

*No risk means the probability of the predicted discharges exceeding the screening dose rate of 10 $\mu\text{Gy h}^{-1}$ is less than one per cent.

700

There is some variation between the results obtained using the predicted activity concentrations Westinghouse provided and those by our independent contractor.

701

For the marine assessment, the results predicted using our data are significantly lower than those using the Westinghouse input data. This is because in its assessment Westinghouse used discharge rates that were converted into activity concentrations using the IAEA SRS 19 methodology. In our assessment we used activity concentrations derived using PC CREAM. The SRS 19 method is a more conservative approach, and, therefore, overestimates the activity concentrations in water and sediment.

702

The results of the terrestrial assessments are different because they were carried out at different tiers of the ERICA tool. However, the results using both the Westinghouse input data and our data are two or more orders of magnitude lower than the screening dose rate. The results of the assessments using the R&D128 approach were not significantly different.

703

We consider the assessment Westinghouse carried out to be conservative and reasonable at the GDA stage, and we consider that Westinghouse has used an appropriate approach to assessing the radiological impact of the AP1000 on non-human species.

704 We note, however, that the marine tier 2 results exceed the screening dose rate of $10 \mu\text{Gy h}^{-1}$, but they do not exceed the dose limit of $40 \mu\text{Gy h}^{-1}$ that we have agreed with Natural England in order to protect Natura 2000 sites. The results of our assessments do not exceed the screening dose rate.

705 **We conclude that at the GDA stage we consider that the maximum predicted gaseous releases and liquid discharges for an AP1000 at the generic site are unlikely to pose a risk to non-human species. We consider that the assessment is suitably conservative at this stage of the GDA process. We recognise that a detailed site-specific assessment of the radiological impact from the AP1000 will be required for any site where the AP1000 is proposed.**

15 Other environmental regulations

15.1 Water abstraction

706 We conclude that the Westinghouse proposal to abstract cooling water only from the open sea is unlikely to require an abstraction licence from us.

Consultation Question 10: Do you have any views or comments on our preliminary conclusions on the abstraction of water?

707 Westinghouse says that the AP1000 will need supplies of freshwater for several purposes and assume for GDA that this will be from a mains supply (ERs2.7):

- a) for the demineralised water treatment plant that provides treated water for the primary and secondary circuits;
- b) to provide potable water for drinking and sanitation needs (showers and lavatories);
- c) to supply the fire protection system.

Westinghouse provides normal and maximum flows for each use in ER Figure 2.7-1, that is up to $100 \text{ m}^3 \text{ h}^{-1}$ in normal operation.

708 Providing freshwater will be a site-specific issue, and we have not considered this at GDA. If a site needs abstracted surface water, then the operator will need to obtain an abstraction licence (under the Water Resources Act 1991) from us before any abstraction takes place.

709 Westinghouse only considers a coastal site at GDA and assumes cooling water requirements will be met by abstraction of seawater. We accept that direct cooling may be the best option for estuarine and coastal sites, provided that the highest standards of planning, design and mitigation are followed (see Environment Agency 2010b).

710 The AP1000 has two cooling systems:

- a) the circulating water system (CWS) (ERs2.7.1) supplies seawater to remove heat from the:
 - i) main condensers;
 - ii) the turbine building closed cooling water system (TCS) heat exchangers;
 - iii) the condenser vacuum pump seal water heat exchangers.
- b) the service water system (SWS) (ERs2.7.2) supplies seawater to remove heat from the non-safety related component cooling water system (CCS) heat exchangers in the turbine building.

711 Westinghouse predicts the following flows and return temperatures (ERs4.2.3.3):

- a) CWS: $38 \text{ m}^3 \text{ s}^{-1}$ at $14 \text{ }^\circ\text{C}$ warmer than intake;
- b) SWS: $1.3 \text{ m}^3 \text{ s}^{-1}$ at $18.3 \text{ }^\circ\text{C}$ warmer than intake.

The returning flows are combined at the seawater return sump where the temperature will be $14.15 \text{ }^\circ\text{C}$ warmer than intake.

712 The abstraction of water from the open sea will not normally require an abstraction licence from us, unless the particular location of the abstraction means that it falls

- within the definition of inland waters. We have assumed for GDA that the cooling water intake will be from the open sea and that the abstraction will not require licensing. We will need to examine carefully the location of abstraction for each specific site to decide whether a licence is needed. Potential operators will need to contact us for advice, giving full details of their proposals.
- 713 The abstracted seawater will need to be filtered to remove debris, including seaweed before it is used. Westinghouse has not provided information on this topic at GDA. Handling the removed material will need to be considered for each site, as it will be a waste for disposal. In some cases, it can be macerated and returned to the sea. The operator for each specific site will need to discuss with us the need for waste or discharge permits for the option chosen for the site. We have not assessed this matter at GDA.
- 714 We have concerns on the seawater intake design because of possible damage to fish and invertebrates through entrapment and impingement on filter screens. We published a report in 2010 '*Cooling Water Options for the New Generation of Nuclear Power Stations in the UK*' (Environment Agency 2010b) that explains the issues and reviews mitigation measures. We expect operators to contact us at the early stages of site-specific designs so that we can advise on techniques to minimise the impact of cooling water intakes on the marine ecology. We will assess and comment on the proposed intake design in our role as statutory consultee in the planning process. If the abstraction were licensable (under the Water Resources Act 1991), then we would also seek to influence the design through agreed conditions on the abstraction licence, for example, requiring the operator to install mitigation measures and/or carry out monitoring programmes.
- 715 **We conclude that the Westinghouse proposal to abstract cooling water only from the open sea is unlikely to require an abstraction licence from us. The design of the sea water intake to minimise damage to marine life will be a site-specific issue.**

15.2 Discharges to water of non-radioactive substances

716 We conclude that we should be able to permit the discharges of non-radioactive substances to water from an AP1000 under EPR 10.

Consultation Question 11: Do you have any views or comments on our preliminary conclusions on discharges of non-radioactive substances to water?

717 We have assessed (within the constraints imposed by the generic site) whether discharges to water from the AP1000 could pose an unacceptable risk to the environment.

718 The underlying objective of our detailed assessment is to determine whether we could grant a discharge permit for the AP1000 design, subject to any matters that can only be dealt with at the site-specific stage.

719 The key issues for assessing non-radioactive discharges to water are the discharge of certain dangerous substances and the discharge of thermally adjusted cooling waters. Both these matters would be subject to control by an environmental permit from us (Environmental Permitting Regulations 2010).

720 Dangerous substances (as specified under the Dangerous Substances Directive) are toxic and pose the greatest threat to the environment and human health. The Directive requires that we either eliminate or minimise pollution by these substances. We define pollution by dangerous substances as exceeding environmental quality standards (EQSs) in the water. The EQS defines a concentration in the water below which we are confident that the substance will not have a polluting effect or cause harm to plants and animals.

721 The requirements of the Dangerous Substances Directive are now integrated in the Water Framework Directive and the Dangerous Substances Directive will be fully repealed in 2013. The Water Framework Directive is designed to improve and integrate the way water bodies are managed throughout Europe. Member states must aim to reach good chemical and ecological status in inland and coastal waters by 2015. This overarching piece of legislation will have wide implications for any new nuclear power station built in Europe, not least of all because EQS compliance serves as a key indicator of both chemical and ecological status.

722 Heat is defined as pollution under the Water Framework Directive. Under the directive, draft temperature standards have been published based on the requirements for coastal and transitional waters of good ecological status. In common with other directly cooled power stations (both conventional and nuclear), the AP1000 will produce and discharge large volumes of thermally adjusted cooling waters. The main environmental effects of these thermal discharges relate to temperature rise and cooling water system biocide residues.

723 Other important legislation to be considered is the Habitats Directive. The Directive created a network of protected areas around the EU called European Sites which form the 'Natura 2000' network. These sites are found in abundance at various locations around the UK's coastline and could potentially be affected by new nuclear power station discharges.

724 At GDA it is not possible to assess the AP1000 discharge under the Habitats Directive. To determine whether a discharge is 'relevant' under the legislation, we would need to pinpoint it to a particular location. If the discharge were 'relevant', we would apply increasingly rigorous assessment stages, ultimately requiring site-specific knowledge

- about how a discharge plume would behave in the receiving water. Detailed dispersion modelling could be required and this is outside the scope of GDA.
- 725 Westinghouse has carried out a generic impact assessment of direct (or once-through) cooling, in terms of water quality and ecology. This is useful as it demonstrates an awareness of the relevant issues, highlights potential impacts and identifies mitigation measures. However, as the assessment is based on a generic UK site, the conclusions can only be qualified through further site-specific work. Westinghouse has identified the need for such work to properly assess potential impacts, particularly those relating to habitats and species.
- 726 Westinghouse says that the AP1000 will generate the following liquid effluents:
- a) effluent from the liquid radwaste system (WLS)(ERs3.4.3). The radioactivity of this effluent is dealt with in our chapter 10, but the effluent will also contain chemicals and metals, for example corrosion products, that will need to be covered in a discharge permit from us;
 - b) effluent from the wastewater system (WWS) that serves the drains in the non-radioactive building areas of the AP1000. The effluent is collected in sumps and then pumped through an oil separator to the wastewater retention basin for settling of suspended solids and treatment, if required. The basin is discharged, after sampling and appropriate discharge approval, to the seawater return sump through release point W11, (ERs4.2.1.1 and ER Figure 6.2-2);
 - c) effluent from the sanitary drainage system that serves rest rooms and locker room facilities in non-radiologically controlled areas. The system design will be site-specific and has not been assessed at GDA.
- 727 The following systems also discharge into the wastewater system (WWS):
- a) the demineralised water treatment system treats raw water using filters, reverse osmosis and electrodeionisation. Chemicals are added in trace quantities to adjust pH and to act as an anti-scalant. The reject flow from reverse osmosis is sent to the WWS (ERs4.2.2.1);
 - b) the steam generator blowdown system takes a blowdown from each steam generator and treats it to reduce impurities. Blowdown is normally recycled into the secondary system but, in event of high impurity levels, can be discharged to the WWS (ERs4.2.2.2). If significant radioactivity is detected in the secondary side systems, blowdown is re-directed to the liquid radwaste system;
 - c) the condensate system provides feedwater to the secondary system. An ion exchange bed is used to polish the feedwater at start-up, the bed is rinsed before use and the rinse water sent to the WWS (ERs4.2.2.3).
- 728 The main chemicals used in the AP1000 and associated with the liquid radioactive effluent are (ERs2.9.1 and s4.2):
- a) boric acid used as a neutron absorber and added to:
 - i) the coolant (concentration from 612 to 2700 ppm);
 - ii) the spent fuel pool and fuel transfer canal;
 - iii) the in-containment refuelling water storage tank/refuelling cavity;
 - iv) the cask wash-down pit.(Concentrations for ii, iii and iv are all 2700 ppm)
 - b) lithium hydroxide added to the coolant to offset the acidity of the boric acid to prevent equipment corrosion;
 - c) hydrazine used as an oxygen scavenger in the feedwater at start-up;
 - d) zinc acetate added to the coolant to be incorporated into oxide films on wetted reactor components to reduce corrosion;

- e) trace metals such as iron, nickel, copper and chromium from corrosion and erosion where coolant and other process waters contact equipment. Westinghouse was unable to provide predictions for quantities of these at GDA. However, effluents are filtered and, in the case of effluent from treating coolant, passed through ion exchange resins. These techniques will minimise the quantities of metals present in discharges.
- 729 Westinghouse lists other chemicals used in the AP1000 and not associated with the radioactive effluent in ER table 2.9-1. Chemicals include ammonium hydroxide, used for pH control; ammonium chloride, used as an algacide; sodium hypochlorite, used as a biocide; and polyphosphate, used as an anti-scalant.
- 730 Seawater cooling circuits need to be protected from biological fouling when the seawater inlet temperature is above 10°C, assumed to be for six months of the year. The AP1000 will use sodium hypochlorite as a biocide (30 per cent solution from an 11.4 te tank). The system will leave residual oxidants, chlorine and halogenated by-products such as bromoform in the returning seawater. (ERs4.2.5.1)
- 731 Westinghouse claims the use of sodium hypochlorite will be minimised by using BAT in the design of the cooling system. ER Table 4.2-3 provides a list of techniques to be considered. Many of these relate to site-specific conditions or operator procedures and, therefore, we could not readily assess for GDA, but they will be important concerns for site-specific permitting.
- 732 Westinghouse has provided an estimate of the impact of biocide dosing on the receiving environment, quantifying the likely concentration of total residual chlorine against its respective EQS. While Westinghouse concludes that the predicted discharge will exceed the EQS at the point of discharge, it expects the concentration to decrease rapidly upon mixing with seawater. It says that there is minimal risk that the EQS would be exceeded at the edge of the mixing zone, but site-specific monitoring would be necessary to prove this. It acknowledges that the required dosing regime is highly site-specific and depends on local water quality conditions. This is why we have not assessed this matter at GDA. Future work involving using local water quality information and dispersion modelling of each discharge would be necessary to support a site-specific application for a discharge permit.
- 733 Suspended solids may come from dirt collected in drain effluents. The waste water retention basin allows for settling of suspended solids before discharge. (ERs4.2.1.1)
- 734 Westinghouse has not provided information on chemical oxygen demand (COD) in effluents from the AP1000 at GDA. An operator will need to provide this information to complete a site-specific permit application.
- 735 Liquid effluents are collected for monitoring before discharge into the seawater sump, where there is immediate and substantial dilution provided by the flow of returning cooling water, approximately $39 \text{ m}^3 \text{ s}^{-1}$. The two main effluent streams, from the liquid radwaste system and the wastewater system, discharge as follows:
- radioactive effluents are collected in the six monitor tanks of the liquid radwaste system and discharged through point W7, a pumped discharge with a design flow rate of $22.7 \text{ m}^3 \text{ h}^{-1}$;
 - non-radioactive effluents from the waste water system are collected in the wastewater retention basin and are discharged through point W11 at a maximum design flow rate of $408 \text{ m}^3 \text{ h}^{-1}$.
- We assume the flow monitoring and sampling equipment at points W7 and W11 will be used for both radioactive and non-radioactive discharge measurements.
- 736 Westinghouse has provided an impact assessment for some of the substances discharged to sea from the AP1000. It has estimated annual discharges of chemicals and calculated discharge concentrations based on dilution in the annual flow of seawater cooling ($1.24 \times 10^9 \text{ m}^3$), ER Table 4.2-2:

Chemical	Quantity (kg y ⁻¹)	Annual average concentration (AAC)(µg l ⁻¹)	Environmental quality standard (EQS)(µg l ⁻¹)	AAC/EQS (%)
Boric acid (boron)	≤7884 ≤(1380)	1.1 (as boron)	7000	0.02
Lithium hydroxide	6.4	0.005	-	-
Zinc acetate	<1.2	<3.4 x 10 ⁻⁵ (as Zinc)	40	0.00009
Trace metals in chemicals	3.3 (based on 1 ppm)	0.0027	lowest EQS is mercury at 0.3	0.9
Sodium hypochlorite	< 121490	< 200	-	-
Ammonium chloride/hydroxide	< 35,670	< 11 (ammonia as N)	21 (our proposed EAL for unionised ammonia as N)	-
Hydrazine	370	0.3	-	-

- 737 Westinghouse assumed a worst case of 1 ppm metal contamination of bulk chemicals used to predict the discharge concentration of trace metals. The predicted discharge concentration is less than 1 per cent of the lowest EQS (mercury). We do not consider substances with discharge concentrations at less than 1 per cent EQS to be significant, and do not require detailed dispersion modelling or further impact assessment. This follows the screening principles set out in our H1 assessment guidance (Environment Agency, 2010e). H1 is used for assessing the risks to the environment and human health from facilities which are applying for a permit under the Environmental Permitting Regulations 2010. Insignificant risks are screened out and more detailed assessment is only needed where the risks justify it.
- 738 As mentioned above, Westinghouse does not predict levels of corrosion products such as iron, nickel, copper and chromium that will be expected in trace quantities in the radioactive effluent.
- 739 An operator will need to provide more accurate predictions of all metals liable to be contained in the liquid effluents to complete a site-specific permit application. This should include details of corrosion products arising from both the primary and secondary circuits and impurities within bulk raw materials.
- 740 We have commissioned a study to help us understand the range and quantity of chemicals discharges: '*Chemical Discharges from Nuclear Power Stations: Historic Releases and Implications for BAT*' (Science Report SC090012/SR). The report should be ready to support our GDA decision in 2011 and our site-specific permitting work.
- 741 Our procedures for permitting dangerous substances to coastal waters are based on the relationship between the discharge concentration and the EQS. We again apply a staged approach which involves more rigorous assessment as each stage is passed. The rigour of each stage is reflected in the need for increasing levels of site-specific information and possibly dispersion modelling studies.
- 742 If the discharge concentration of a substance is much less than the EQS, then it is considered insignificant. At the other end of the scale, we may have to define what is an acceptable *mixing zone* for a particular substance, taking account of local constraints such as sensitive ecological areas and specify appropriate limits for that substance on a discharge permit.

- 743 As mentioned above, more detailed information on dangerous substances, particularly metals, would be required in support of a site-specific permit application.
- 744 Westinghouse claims that the return temperature of seawater used for cooling will be 14-15 °C warmer than at intake. It has provided no information on impact, stating that a site-specific definition of mixing zone and impact evaluation will be required. This is consistent with our understanding and, therefore, we have not assessed potential thermal impact under GDA. Due to the highly localised data requirements of dispersion modelling, a detailed study will be required in support of site-specific application for a discharge permit.
- 745 Westinghouse claims that the wastewater retention basin has enough volume to retain any unplanned emissions of effluents or spillages. Effluents that cannot be discharged can then be treated or disposed of off-site (ERs4.2.6.1). Westinghouse states that the design of the wastewater retention basin is a site-specific matter and has not provided any detailed information. We have, therefore, not been able to assess this aspect at GDA. The operator will be required to submit the design details, including justification of retention volume, to support a site-specific permit application.
- 746 Westinghouse says that storm water falling on the site of an AP1000 will be collected into a storm water pond. The storm water system will need to incorporate an oil separator to cope with any oil spillage on roads or loading areas. The detailed design will be site-specific and has not been assessed at GDA.
- 747 Westinghouse says that fire water from internal fire fighting would be initially retained within buildings. Fire water used externally should be collected in the storm water pond. In both cases, fire water can be treated or disposed of off-site and should not be discharged in an uncontrolled way.
- 748 We have identified above a number of issues to be resolved at the site-specific permitting stage. This is because in order to fully assess the environmental impact of the AP1000 discharge we require an accurate representation of the behaviour of the receiving waters and of their interaction with the various substances to be discharged. This can only be achieved by computational dispersion modelling, using localised monitoring data – this is outside the scope of GDA. Nevertheless, based on our assessment of the information Westinghouse submitted, we believe, in principle and without prejudice to our formal determination of an application in due course, that we should be able to issue a permit to discharge liquid effluents from the AP1000 to the sea.
- 749 **We conclude that:**
- a) **the predicted discharges of non-radioactive substances from an AP1000 are less than one per cent of any environmental quality standards at the point of disposal to the sea and, therefore should be compatible with the Water Framework Directive aim of achieving good ecological and chemical status in the receiving water.**
 - b) **However, this will depend on our determination of site specific applications and any applications for a permit will need to provide a detailed environmental impact assessment based on dispersion modelling.**

15.3 Pollution prevention for non-radioactive substances

750 We conclude that:

- a) the site of an AP1000 should not need to be permitted by us for a discharge to groundwater;
- b) pollution prevention techniques used in the AP1000 are adequate to prevent any leaks or spills entering groundwater.

Consultation Question 12: Do you agree with our preliminary conclusions on pollution prevention for non-radioactive substances?

751 Under the Environmental Permitting Regulations 2010 (EPR 10), a permit is required for the discharge of certain substances, to groundwater, with the aim of preventing or limiting pollution of groundwater.

752 Westinghouse claims that there are no direct or indirect discharges to groundwater from the AP1000 (ERs4.2.1). In that case, an AP1000 should not need to be permitted by us for a discharge to groundwater under EPR 10.

753 Westinghouse lists the following relevant substances as liable to be on an AP1000 site (ER Table 2.9-3/4):

- a) hazardous substances: hydrazine, halogenated by-products of chlorination of seawater (for example, bromoform), hydrocarbons (fuel oil) and radioactive substances;
- b) non-hazardous pollutants: sodium hypochlorite, metals, phosphates and ammonium hydroxide.

754 Diesel fuel (a hydrocarbon) used by the AP1000 stand-by generators will present a potential risk to groundwater. We will make sure that storage of fuel complies with the Control of Pollution (Oil Storage) (England) Regulations 2001 and confirm, by inspection during construction, that any oil handling facilities will prevent any oil leaks or spills reaching groundwater.

755 Westinghouse claims that all AP1000 chemical storage tanks will be provided with secondary containment (bunds) (ERs2.9.4). Details of the secondary containment are provided in the ER Table 2.9-6. We note that some containment issues are deferred until the site-specific design stage.

756 The borehole network discussed in section 8.3 of this document (for monitoring of radioactive contamination) should also be used to monitor for a range of non-radioactive substances to be agreed at the site-specific stage.

757 **We conclude that:**

- a) **the site of an AP1000 should not need to be permitted by us for a discharge to groundwater under the Environmental Permitting Regulations 2010;**
- b) **pollution prevention techniques used in the AP1000 are adequate to prevent any leaks or spills entering groundwater.**

15.4 Environmental Permitting Regulations 2010 (EPR 10) Installations

758 We conclude that the AP1000 does not include any installations that contain activities described in Part 2 of Schedule 1 of EPR 10.

Consultation Question 13: Do you agree with our preliminary conclusions on EPR 10 Schedule 1 activities?

759 The Environmental Permitting Regulations 2010 (before 1 April 2008, this was PPC (Pollution Prevention and Control Regulations 2000)) require operators of installations containing certain activities to apply for and obtain a permit from us before commencing operations. In relation to the AP1000, combustion activities are relevant:

- a) in Part A(1)(a) – where fuel is burned in two or more appliances with an aggregated rated thermal input of 50 MW or more; or
- b) in Part B(a) – burning any fuel in a compression ignition engine, with a rated thermal input of 20 or more megawatts, but a rated thermal input of less than 50 MW.

760 The AP1000 will have two stand-by diesel generators each providing 4 MW of electricity. Westinghouse states that the maximum rated thermal input of each will be 12.9 MW. The aggregate of the two units is therefore 25.8 MW – below the threshold for a Part A EPR activity. Further, the individual units are less than 20 MW and will not fall into Part B. The operator for a single AP1000 site (the GDA case) will not require an EPR 10 permit for the diesel generators. If more than one AP1000 were to be proposed for one location, the operator will need to discuss with us the implications for EPR 10 permitting. (ERs4.1.1.2)

761 The diesel generators will require a supply of fuel. The fuel oil storage tank facility of capacity 454 m³ will need to comply with the Control of Pollution (Oil Storage) (England) Regulations 2001.

15.5 Management of non-radioactive waste

762 We conclude that Westinghouse's strategy and proposals for the management of non-radioactive waste from the AP1000 are consistent with the waste hierarchy and the objective that waste is recovered or disposed of without endangering human health and without using processes or methods that could harm the environment.

763 However, our conclusion is subject to the following other issue:

- a) Waste from construction activities shall be included in the waste strategy for each site at site-specific permitting (AP1000-OI09).

Consultation Question 14: Do you have any views or comments on our preliminary conclusions on non-radioactive waste?

764 All non-radioactive waste management is subject to the requirements of the Environmental Permitting Regulations, and/or certain sections of the Environmental Protection Act 1990 and, where relevant, the Hazardous Waste Regulations 2005. We, therefore, expect Westinghouse's strategy and proposals for non-radioactive waste management to be consistent with:

- a) the waste hierarchy (EC, 2006);
- b) the objective that waste is recovered or disposed of without endangering human health and without using processes or methods that could harm the environment (EC, 2006);
- c) the requirement that waste shall not be treated, kept or disposed of in a manner likely to cause environmental pollution or harm to human health (HMSO, 1990);
- d) the duty to take reasonable measures to prevent waste from escaping (HMSO, 1990).

765 Westinghouse's IWS document outlines its current strategy for managing radioactive and non-radioactive waste produced over the whole lifecycle of the site, including operational and decommissioning activities. The IWS does not include waste from construction activities.

766 Westinghouse states in its IWS that the requirements of the waste management hierarchy are inherent in many aspects of the AP1000 design.

767 Westinghouse's integrated waste strategy (IWS) states that the site's integrated management system will address the following:

- a) control of activities to prevent and minimise waste arisings;
- b) control of waste management activities, which include waste classification and segregation and application of the waste hierarchy;
- c) maintain arrangements and equipment required to: minimise waste arising, management of waste, and monitoring and sentencing of waste;
- d) check the effectiveness of arrangements and equipment required to: minimise waste arising, management of waste, and monitoring and sentencing of waste;
- e) sharing and using good practice across waste streams and projects on the site;
- f) sharing and using good practice with other sites;
- g) identifying research and technology requirements relating to waste management;

- h) identifying competence and skills requirements relating to waste management;
- i) managing records and information;
- j) managing interfaces with other sites.

768 Westinghouse states in its IWS that the expected volumes of conventional solid waste generated will benefit from good management arrangements together with the features inherent in the AP1000. It says that these features, when combined with best industry practice operating regimes, lead to a reduction in the volumes of conventional waste generated. Westinghouse's strategy for conventional waste arisings is that they are collected and sorted onsite before being transported to appropriate permitted facilities for recovery or disposal.

769 The sources of non-radioactive solid waste are summarised in Table 4.3-1 of the ER. A schematic showing the proposed treatment and disposal of non-radioactive waste is shown in Figure 4.3-1 of the ER.

770 **We conclude that Westinghouse's strategy and proposals for the management of non-radioactive waste are consistent with:**

- a) **the waste hierarchy;**
- b) **the Waste Framework Directive objective that waste is recovered or disposed of without endangering human health and without using processes or methods that could harm the environment;**
- c) **the requirement of *The Environmental Protection Act 1990* (EPA 90) that waste shall not be treated, kept or disposed of in a manner likely to cause environmental pollution or harm to human health;**
- d) **the duty under EPA 90 to take reasonable measures to prevent waste from escaping.**

However, Westinghouse has not included waste from construction activities in its waste strategy, which will be required for each site at site-specific permitting (other issue AP1000-OI09).

15.6 Control of Major Accident Hazards Regulations (COMAH)

771 We conclude that an AP1000 will be a COMAH lower tier installation.

Question 15: Do you have any views or comments on our preliminary conclusions on COMAH substances?

772 Westinghouse estimated the quantities of chemicals potentially to be stored on the site of an AP1000 and compared this with the qualifying quantities of named dangerous substances to which COMAH applies (COMAH (Amendment) Regulations 2005). The most significant chemicals are shown below (from ER Tables 2.9-1/2):

Chemical	Stored quantity (te)	Lower tier threshold (te)	Upper tier threshold (te)
Hydrazine (35% solution)	1.1 (as hydrate)	0.5	2
Hydrogen	0.8	5	50
Petroleum spirits (diesel for back-up generators)	467	2,500	25,000

773 Westinghouse, therefore, states that the site of an AP1000 will become a COMAH lower tier installation because of the expected storage quantity of more than 0.5 tonne of hydrazine hydrate. (ERs2.9.2.1)

774 The operator of a lower tier installation needs to notify the Competent Authority (CA) (ourselves and HSE) and prepare a major accident prevention policy (MAPP) before starting operations. The operator also needs to be able to demonstrate to the CA that he has taken all measures necessary to prevent major accidents and limit their consequences to people and the environment. The notification, MAPP and demonstration will be site-specific issues for the operator, and we have not considered this at GDA – our main purpose at GDA was to find out if COMAH would apply.

775 Westinghouse claims that other substances listed in ER Tables 2.9-1/2 are either not hazardous or not stored in sufficient quantity to be considered under COMAH.

776 Hydrazine is used in small quantities as an additive to water in the secondary circuit to consume residual oxygen. Hydrazine is a named carcinogen in the COMAH Regulations – hence the low threshold values – and its main risk is to the workforce.

777 Hydrazine hydrate is a liquid and could have a pathway to the sea in an accident through the site drains. It is classified as dangerous to the environment and is toxic to aquatic organisms. However, its toxicity diminishes with concentration, it is not very bio-cumulable and tends to decompose in the aquatic environment.

778 Westinghouse claims that the following preventative measures will be effective in preventing the accidental pollution of the marine environment with hydrazine (ERs5.4.5):

- a) primary containment in steel tank or tote container in turbine hall;

- b) secondary containment provided by chemical area containment dyke in turbine hall;
- c) spill collection in turbine hall sumps;
- d) final barrier is retention in the waste water retention basin;
- e) external spills controlled by temporary spill barriers;
- f) manual intervention to neutralise spills.

779 Westinghouse claims the above measures make it unlikely that the whole stored quantity of hydrazine (1.1 te) will reach the sea. If hydrazine does enter the sea, then deoxygenation will be the most significant effect. However, Westinghouse believes this would be of a minor, limited spatial extent, for a short duration and local to the release point (ERs5.4.4). We agree with this qualitative risk assessment at this time for GDA. It would appear that a major accident to the environment is highly unlikely from an accident involving hydrazine stored on the AP1000. The operator will need to have a more detailed risk assessment available before site operations commence.

780 **We conclude that:**

- a) **the AP1000 will store hydrazine (a dangerous substance as defined in the COMAH regulations) in quantities exceeding the lower tier COMAH threshold and will, therefore, be a COMAH lower tier installation;**
- b) **the Westinghouse qualitative assessment that a major accident to the environment involving hydrazine is highly unlikely is reasonable. A more detailed risk assessment will need to be provided by the operator before any hydrazine is first stored;**
- c) **the operator should be able to demonstrate that all measures necessary to prevent major accidents and limit their consequences to people and the environment have been taken for an AP1000.**

781 The above conclusion relates only to the consequences of major accidents to the environment from hydrazine storage. Our partner in the Competent Authority for COMAH regulation, HSE, is responsible for assessing matters relating to impacts on people.

15.7 EU Emissions Trading Scheme

- 782 This scheme is one of the policies introduced across the European Union (EU) to help it meet its greenhouse gas emissions reduction target under the Kyoto protocol.
- 783 An AP1000 will have 25.8 MW (thermal) of combustion plant (see above) and will be an installation required to hold a greenhouse gas emissions permit. An operator of a specific site will need to obtain such a permit from us before any combustion plant operates.

16 Conclusion

784 At this stage, we propose that we could issue an interim statement of design acceptability for the AP1000. This would be subject to the GDA Issues and other issues identified throughout this document and in Annex 1 and Annex 2. In particular, it would be valid only for a site meeting the identified generic site characteristics (see section 14.2 above).

785 A draft interim statement of design acceptability is included at Annex 1 to help inform this consultation. But we will not make a final decision on whether to issue a statement of design acceptability until we have considered all relevant responses to this consultation.

Consultation Question 16: Do you have any views or comments on our overall preliminary conclusion on acceptability of the design?

Consultation Question 17: Do you have any overall comments to make on our assessment, not covered by previous questions?

References

- (Anderson, 2009) Andersson, P., Beaugelin-Seiller, K., Beresford, N. A., Copplestone, D., Della Vedova, C, Garnier-Laplace, J., Howard, B. J., Howe, P., Oughton, D.H., Wells, C., and Whitehouse, P., Numerical Ranges for Protecting Species from Radiation in the Environment: Proposed Levels, Underlying Reasoning and Recommendations (2009).
http://www.ceh.ac.uk/protect/outputs/documents/PROTECT_D5_final.pdf
- (Beresford, 2007) Beresford, N., Brown, J., Copplestone, D., Garnier-Laplace, J., Howard, B., Larsson, C., Oughton, D., Prohl, G. and Zinger, I., An Integrated Approach to the Assessment and Management of Environmental Risks from Ionising Radiation (2007).
<https://wiki.ceh.ac.uk/download/attachments/115017395/D-Erica.pdf?version=1>
- (BERR, 2008a) *Meeting the Energy Challenge. A White Paper on Nuclear Power*, BERR, January 2008.
<http://www.berr.gov.uk/files/file43006.pdf>
- (BERR 2008b) Consultation on Funded Decommissioning Programme Guidance for New Nuclear Power Stations
http://www.decc.gov.uk/en/content/cms/what_we_do/uk_supply/energy_mix/nuclear/new/waste_costs/waste_costs.aspx
- (BSI, 2005) BS EN ISO/IEC 17025:2005 General requirements for the competence of testing and calibration laboratories
- (DTI, 2004) The Decommissioning of the UK Nuclear Industry's Facilities, Department of Trade and Industry, Sept 2004.
<http://www.berr.gov.uk/files/file30124.pdf>
- (DECC 2009a) Statutory Guidance to the Environment Agency concerning the regulation of radioactive discharges into the environment, Department of Energy and Climate Change and Welsh Assembly Government, 2009.
http://www.decc.gov.uk/media/viewfile.ashx?filepath=what%20we%20do/uk%20energy%20supply/energy%20mix/nuclear/radioactivity/discharges_ofradioactivity/1_20091202160019_e_@@_guidanceearadioactivedischarges.pdf&filetype=4
- (DECC 2009b) Draft Nuclear National Policy Statement
<https://www.energynpsconsultation.decc.gov.uk/nuclear/>
- (DECC 2009c) Consultation on proposed Regulatory Justification decisions on new nuclear power stations (AP1000 and EPR)
http://www.decc.gov.uk/en/content/cms/consultations/reg_just_cons/reg_just_cons.aspx
- (Defra et al, 2008) *Managing Radioactive Waste Safely. A Framework for Implementing Geological Disposal*, (Cm 7386), Defra, BERR and the devolved administrations for Wales and Northern Ireland, June 2008.
<http://www.official-documents.gov.uk/document/cm73/7386/7386.pdf>
- (Defra, 2000) The Radioactive Substances (Basic Safety Standards) (England and Wales) Direction 2000, Defra, May 2000.]

- (Defra, 2010) Environmental Permitting Guidance, Radioactive Substances Regulation For the Environmental Permitting (England and Wales) Regulations 2010, March 2010, Version 1.1
<http://www.defra.gov.uk/environment/policy/permits/documents/ep2010radioactive.pdf>
- (EC, 2006) Directive 2006/12/EC of the European Parliament and of the Council of 5 April 2006 on waste. Official Journal L114, 27/04/2006, p. 9-21.
<http://eur-lex.europa.eu/LexUriServ/LexUriServ.do?uri=OJ:L:2006:114:0009:0021:EN:PDF>
- (Environment Agency, 1999a) Monitoring of Radioactive Releases to Atmosphere from Nuclear Facilities. Technical Guidance Note (Monitoring). M11 1999 ISBN 0 11 310133 3.
- (Environment Agency, 1999b) Monitoring of Radioactive Releases to Water from Nuclear Facilities. Technical Guidance Note (Monitoring). M12 1999 ISBN 0 11 310135 X.
- (Environment Agency, 2005) Development of Guidance on Setting Limits on Radioactive Discharges to the Environment from Nuclear Sites, (Science Report: SC010034/SR, Environment Agency, December 05)
<http://publications.environment-agency.gov.uk/pdf/SCHO1205BIVK-e-e.pdf>
- (Environment Agency, 2006) Initial Radiological Assessment Methodology (Parts 1 and 2) Science Report SC030162/SR1
<http://publications.environment-agency.gov.uk/pdf/SCHO0106BKDT-e-e.pdf>
- (Environment Agency, 2007) Process and Information Document for Generic Assessment of Candidate Nuclear Power Plant Designs, Environment Agency, Jan 2007.
<http://publications.environment-agency.gov.uk/pdf/GEHO0107BLTN-e-e.pdf>
- (Environment Agency, 2008a) Environment Agency Generic design assessment of new nuclear power plant designs, Statement of findings following preliminary assessment of the submission by Westinghouse Electric Company LLC for its AP1000 design, March 2008.
<http://www.hse.gov.uk/newreactors/reports/ap1000.pdf>
- (Environment Agency, et al 2008b) *Radioactivity in Food and the Environment, 2007* (RIFE – 13), Environment Agency, Food Standards Agency, Northern Ireland Environment Agency and Scottish Environment Protection Agency, 2008.
- (Environment Agency, et al 2009a) *Radioactivity in Food and the Environment, 2008* (RIFE – 14), Environment Agency, Food Standards Agency, Northern Ireland Environment Agency and Scottish Environment Protection Agency, 2009.
- (Environment Agency, 2009b) Creating a better place 2010–2015: Our Corporate Strategy, Environment Agency 2009
<http://publications.environment-agency.gov.uk/pdf/GEHO1109BQXE-e-e.pdf>

- (Environment Agency, 2009c) Considerations for Radioactive Substances Regulation under the Radioactive Substances Act at Nuclear Sites in England and Wales, Environment Agency, Jan 2009 (version 2).
<http://publications.environment-agency.gov.uk/pdf/PMHO0106BKDG-e-e.pdf>
- (Environment Agency, 2009d) Environment Agency, Habitats Assessments for Radioactive Substances (2009)
<http://publications.environment-agency.gov.uk/pdf/SCHO0309BPML-e-e.pdf>
- (Environment Agency, 2010a) Sampling requirements for stack emission monitoring Technical Guidance Note (Monitoring). M1 v6 2010
<http://publications.environment-agency.gov.uk/pdf/GEHO0110BRRO-E-E.pdf>
- (Environment Agency, 2010b) Cooling Water Options for the New Generation of Nuclear Power Stations in the UK (Science Report: SC070015/SR3, Environment Agency 2010)
- (Environment Agency, 2010c) RGS, No RGN RSR 1: Regulatory Environmental Principles (REPs), 2010
<http://publications.environment-agency.gov.uk/pdf/GEHO0709BQSB-e-e.pdf>
- (Environment Agency, 2010d) RGS, No RGN RSR 2: The regulation of radioactive substance activities on nuclear licensed sites, 2010
<http://www.environment-agency.gov.uk/static/documents/Business/GEHO0310BSGF-E-E.pdf>
- (Environment Agency, 2010e) Horizontal Guidance Note H1 – Environmental risk assessment for permits
<http://publications.environment-agency.gov.uk/pdf/GEHO0410BSHR-e-e.pdf>
- European Utility Requirements European Utility Requirements for LWR Nuclear Power Plants Revision C April 2001 (Volume 2, Chapter 2, section 5.2)
<http://www.europeanutilityrequirements.org/eur.htm>
- (HMSO, 1990) Environmental Protection Act 1990, HMSO.
http://www.opsi.gov.uk/acts/acts1990/ukp_ga_19900043_en_1
- (HPA, 2005) Ionising Radiation Exposure of the UK Population – 2005 Review (HPA-RPD-001), Health Protection Agency, May 2005.
http://www.hpa.org.uk/web/HPAwebFile/HPAweb_C/1194947389360
- (HPA, 2009) Application of the 2007 ICRP Recommendations to the UK – Advice from the Health Protection Agency, RCE-12, July 2009
http://www.hpa.org.uk/web/HPAwebFile/HPAweb_C/1246519364845
- (HSE, 2008) Nuclear Power Station Generic Design Assessment – Guidance to Requesting Parties, HSE, Aug 2008 (version 3).
<http://www.hse.gov.uk/newreactors/ngn03.pdf>
- (HSE, 2009a) HSE ND Division 6 Assessment Report No. AR09/022 Step 3 Management of Safety and Quality Assurance Assessment of the Westinghouse AP1000. 2009.
<http://www.hse.gov.uk/newreactors/reports.htm>

- (HSE, 2009b) Public Report on the Generic Design Assessment of New Nuclear Reactor Designs. Update on the Public Involvement Process for GDA Step 3 of the Generic Design Assessment Process, HSE GDA-007 November 2009
www.hse.gov.uk/newreactors
- (IAEA, 2004) International Atomic Energy Agency Technical Report Series 422 – Sediment Distribution Co-efficients and Concentration Factors for Species in the Marine Environment (2004).
http://www-pub.iaea.org/MTCD/publications/PDF/TRS422_web.pdf
- (Isukul, 2009) Isukul, A., Assessing Types and Quantities of Solid Radioactive Waste Arising from Operational Discharge Abatement Plants of Pressurized Water Reactors, September 2009 (MSc sponsored by the Environment Agency as part of the EMPOWER project)
- (Joint Regulators, 2009) Report on the Joint Regulators Team Inspection of Westinghouse Arrangements as part of the Generic Design Assessment (Quality Management Arrangements) March-April 2009
<http://www.hse.gov.uk/newreactors/reports/wec-inspection-report-2009.pdf>
- (Joint Regulators, 2010) Management of GDA Outcomes (including GDA scope, HSE DAC, our SODA and GDA Issues), HSE and Environment Agency, 2010
www.hse.gov.uk/newreactors
- (OCNS, 2007) Guidance Document for Generic Design Activities, Office for Civil Nuclear Security, Jan 2007.
<http://www.hse.gov.uk/nuclear/ocns/ocnsdesign.pdf>
- (US NRC) NUREG-0017, "Calculation of Releases of Radioactive Materials in Gaseous and Liquid Effluents from Pressurized Water Reactors (PWRs)," current revision.

Glossary

Activation product: a material that has been subject to a neutron flux and has been made radioactive as a result.

Alpha activity: some radionuclides decay by emitting alpha particles which consist of two neutrons and two protons.

Becquerel: the standard international unit of radioactivity equal to one radioactive transformation per second.

- megabecquerel (MBq) – one million transformations per second;
- gigabecquerel (GBq) – one thousand million transformations per second;
- terabecquerel (TBq) – one million million transformations per second.

Best available techniques (BAT): the latest stage of development (state of the art) of processes, of facilities or of methods of operation that indicate the practical suitability of a particular measure for limiting discharges, emissions and waste. In determining whether a set of processes, facilities and methods of operation constitute the best available techniques in general or individual cases, special consideration shall be given to:

- a. comparable processes, facilities or methods of operation which have recently been successfully tried out;
- b. technological advances and changes in scientific knowledge and understanding;
- c. the economic feasibility of such techniques;
- d. time limits for installation in both new and existing plants;
- e. the nature and volume of the discharges and emissions concerned.

Beta activity: some radionuclides decay by emitting a beta particle. This has the same properties as an atomic electron. If the particle carries a positive charge it is known as a "positron".

Collective dose: the dose received by a defined population from a particular source of public exposure. This is obtained by adding the dose received by each individual in the population, and is expressed in units of man-sieverts (manSv). Within limits, collective dose can represent the total radiological consequences of the source on the group, over a certain period of time.

Critical group: a group of members of the public whose radiation exposure is reasonably similar and is typical of people receiving the highest dose from a given source.

Decommissioning: the process whereby a facility, at the end of its life, is taken permanently out of service and its site is made available for other purposes.

Direct radiation: radiation received directly from a source such as a nuclear power station, instead of indirectly as a result of radioactive discharges.

Discharge: the release of aerial or liquid waste to the environment.

Disposal: includes:

- placing solid waste in an authorised land disposal facility without plans to retrieve it at a later time;
- releases to the environment (emissions and discharges) of gaseous waste (gases, mists and dusts) and aqueous waste;
- transfer of waste, together with responsibility for that waste, to another person.

Dose: a general term used as a measure of the radiation received by man and usually measured in sieverts.

Dose constraint: a restriction on annual dose to an individual from a single source, applied at the design and planning stage of any activity. The dose constraint places an upper bound on the outcome of any optimisation study.

Dose limit: the UK legal dose limit for members of the public from all man-made sources of radiation (other than from medical exposure) is 1 mSv yr⁻¹.

Final SODA: The Statement of Design Acceptability provided when all GDA Issues have been addressed to the satisfaction of the Environment Agency.

Fission: splitting of atomic nuclei.

Fission products: radionuclides produced as a result of fission.

Gamma radiation: some radionuclides emit gamma radiation when they decay (usually accompanied by emission of an alpha or beta particle). A gamma ray is a discrete quantity of electromagnetic energy without mass or charge.

GDA Issues: An issue considered by regulators to be particularly significant, but still resolvable. Where there are GDA Issues, the Statement of Design Acceptability or Design Acceptance Confirmation would be labelled as 'Interim', and the regulators will expect the RPs to produce a Resolution Plan that identifies how the Issue would be addressed. Example GDA Issue: Additional fault transient analysis needs to be completed for large loss of coolant accidents and the results accepted by HSE.

GDA Submissions: These include the totality of documents presented to regulators in GDA, including the Design Reference, the GDA Safety, Security and Environmental Submissions and related supporting references.

GDA Master Document Submission List: This is a 'live' document that documents precisely what GDA submissions have been made, at any one point in time.

Generic Site Envelope: The Requesting Party specified generic siting characteristics for a range of UK sites against which the regulators assess the acceptability of the design safety case. These characteristics, such as seismic hazard, extreme weather events, environmental receptors, etc., should, so far as possible, envelop or bound the characteristics of any potential UK site so that the reactors could potentially be built at a number of suitable UK locations.

High level waste (HLW): waste in which the temperature may rise, as a result of its radioactivity, to an extent that it has to be accounted for in designing storage or disposal facilities.

Interim SODA: An interim Statement of Design Acceptability while there are remaining GDA Issues.

Intermediate level waste (ILW): waste with radioactivity levels exceeding the upper boundaries for low level waste but which does not require heat generation to be accounted for in the design of disposal or storage facilities.

Low level waste (LLW): waste containing levels of radioactivity greater than those acceptable for disposal with normal refuse but not exceeding 4 GBq te⁻¹ alpha-emitting radionuclides or 12 GBq te⁻¹ beta-emitting radionuclides.

Man-sievert (manSv): a measure of collective dose.

Nuclear safety related construction: This relates to construction of the main nuclear island, which includes the main reactor building and nuclear auxiliary buildings (such as diesel generator buildings) but does not include, for example, sea defences or the cooling water pump houses that are located away from the nuclear island.

MCERTS: the Environment Agency's Monitoring Certification Scheme. It provides the framework for businesses to meet our quality requirements for monitoring. There are existing MCERTS standards on liquid effluent flow and automatic sampling of liquid effluents which are

relevant to nuclear sites and we are developing a new MCERTS standard on radioanalysis of waters.

Radioactive waste: waste that contains radioactivity above levels specified in the Environmental Permitting Regulations 2010.

Radioactivity: the property of some atomic nuclides to spontaneously disintegrate emitting radiation such as alpha particles, beta particles and gamma rays.

Radiological assessment: an assessment of the radiation dose to members of the public, including that from discharges, which will result from operation or decommissioning of a facility.

Radionuclide: a general term for an unstable atomic nuclide that emits ionising radiation.

Regulatory Issue: in the judgement of the regulators, a finding or concern for which, for the design submitted and the mode of operation proposed, the requesting party has not demonstrated (or may not be able to demonstrate) that risks will be reduced as low as reasonably practicable (ALARP), or that regulatory requirements are met, or that the best available techniques (BAT) will be used to minimise the arisings and impact of conventional and radioactive waste, and which is important enough that it would prevent successfully completing GDA or lead to a Statement of Design Acceptability Issue.

Regulatory Observation (RO): an assessment finding that requires further justification by and/or discussion with the requesting party and further assessment by the regulators in the expectation that it can be resolved to the satisfaction of the regulators. A Regulatory Observation that has not been satisfactorily resolved may, at the discretion of a regulator, be converted to a Regulatory Issue (RI).

Sievert (Sv): a measure of radiation dose received.

- millisievert (mSv) – one thousandth of a sievert;
- microsievert (μ Sv or microSv) – one millionth of a sievert;
- nanosievert (nSv) – one thousandth of one millionth of a sievert.

Stellite: a hard, wear- and corrosion-resistant family of nonferrous alloys of cobalt (20-65%), chromium (11-32%), and tungsten (2-5%); resistance to softening is exceptionally high at high temperature.

Technical Query (TQ): A request for clarification or further information resulting from the inspection/assessment process. A Technical Query is not a Regulatory Observation or a Regulatory Issue, but may result in an Observation or Issue being raised by the regulators to the requesting party where the query cannot be satisfactorily resolved.

Substances and measurements

MW	megawatt
MWe	megawatt electric
GBq y ⁻¹	gigabecquerels per year
MBq y ⁻¹	megabecquerels per year
μ Sv y ⁻¹	microSievert per year
te	tonne

Abbreviations

AP1000™	AP1000 is trademark of Westinghouse Electric Company LLC.
Ar-41	Argon-41 - a radioactive isotope of argon
AGR	Advanced gas-cooled reactor
BAT	Best available techniques
C-14	Carbon-14 – a radioactive isotope of carbon
CO ₂	Carbon dioxide
CH ₄	Methane
C&I	Control and Instrumentation
COMAH	Control of major accident hazards regulations
CVS	Chemical and volume control system
CWS	Circulating water system
DCD	Design Control Document
EQS	Environmental Quality Standard
ER	UK AP1000 Environment Report
ERs*.*	Environment Report section reference e.g. 3.2.2.2
GBq/y	gigabecquerels per year
GDA	Generic Design Assessment
HPA-RPD	Health Protection Agency – Radiation Protection Division
HEPA	High efficiency particulate air (filter)
HLW	High level waste
IAEA	International Atomic Energy Agency
ILW	Intermediate level waste
IWS	Integrated Waste Strategy
JPO	Joint Programme Office
LLW	Low level waste
MBq/y	megabecquerels per year
MW	megawatt
MWe	megawatt electric
NDA	Nuclear Decommissioning Authority
ORE	Occupational radiation exposure
PCSR	Pre-Construction Safety Report
QNL	Quarterly Notification Level
RCCA	Rod Cluster Control Assemblies
RCS	Reactor coolant system
RI	Regulatory Issue
RO	Regulatory Observation
RWMD	Radioactive Waste Management Directorate (of NDA)

SBO	Station black out
SG	Steam generator
SWS	Service water system
te	Tonne
TQ	Technical Query
VFS	Containment air filtration system
VTS	Turbine building ventilation system
WCPD	Worst case plant discharge
WEC	Westinghouse Electric Company LLC
WGS	Gaseous radioactive waste system
WLS	Liquid radioactive waste system
WWRB	Wastewater retention basin
WWS	Wastewater system

Annex 1 – Draft interim statement of design acceptability



Generic assessment of candidate nuclear power plant designs

Interim statement of design acceptability for the UK AP1000 design submitted by Westinghouse Electric Company LLC (Westinghouse)

The Environment Agency has undertaken a Generic Design Assessment of the Westinghouse UK AP1000 design, during the period July 2007 to June 2011, using the process set out in the document Process and Information Document for Generic Assessment of Candidate Nuclear Power Plant Designs¹.

The findings of our assessment are summarised in the document Decision Document for the Generic Design Assessment of Westinghouse’s UK AP1000².

The Environment Agency is satisfied that Westinghouse has demonstrated the acceptability for environmental permitting of the AP1000, as defined in Schedule 1, subject to the GDA issues identified in Schedule 2.

This statement is provided as advice to Westinghouse, under section 37 of the Environment Act 1995. It does not guarantee that any site-specific applications for environmental permits for the AP1000 will be successful.

Name

Date

[name of authorised person]	
-----------------------------	--

Authorised on behalf of the Environment Agency

References

1. Process and Information Document for Generic Assessment of Candidate Nuclear Power Plant Designs, Environment Agency, January 2007.
<http://publications.environment-agency.gov.uk/pdf/GEHO0107BLTN-e-e.pdf>
2. Decision Document for the Generic Design Assessment of Westinghouse’s AP1000, Environment Agency, June 2011.

Schedule 1 – Scope of the GDA

This statement of design acceptability refers to the AP1000 as described in the design reference documentation:

Document reference	Title	Version number	Date of issue
UN REG WEC 000124N	Reference Design Point for the AP1000 A revised version was submitted to the Regulators in April 2010, and is currently under review.	-	23.12.2009

As requested by Westinghouse, the following matters are out of scope for this GDA: None

Schedule 2 – GDA Issues

Reference	GDA Issue	Resolution Plan
AP1000-I1	Decommissioning of the AP1000	A resolution plan will need to be developed for each GDA Issue by Westinghouse, and submitted to the Environment Agency for agreement
AP1000-I2	The radiologically controlled area ventilation system (VAS), and any other ventilation systems where there is potential for the release of radioactive waste to the atmosphere which do not have passive HEPA filtration as part of the design.	
AP1000-I3	Disposability of spent fuel following longer term interim storage pending disposal.	

Schedule 3 – Assessment Reports

Document reference	Title
	Generic design assessment AP1000 nuclear power plant design by Westinghouse Electric Company LLC Assessment Report -
EAGDAR AP1000-01	Management Systems
EAGDAR AP1000-02	Integrated Waste Strategy
EAGDAR AP1000-03	Best Available Techniques to prevent or minimise the creation of radioactive wastes
EAGDAR AP1000-04	Gaseous radioactive waste disposal and limits
EAGDAR AP1000-05	Aqueous radioactive waste disposal and limits
EAGDAR AP1000-06	Solid radioactive waste (LLW and ILW)
EAGDAR AP1000-07	Spent Fuel
EAGDAR AP1000-08	Disposability of ILW and Spent Fuel
EAGDAR AP1000-09	Monitoring of radioactive disposals
EAGDAR AP1000-10	Generic site
EAGDAR AP1000-11	Radiological impact on members of public
EAGDAR AP1000-12	Radiological impact on non-human species
EAGDAR AP1000-13	Other Environmental Regulations
IMAS/TR/2010/06 EAGDAR AP1000-14	Independent Dose Assessment

Annex 2 – Compilation of other issues

The following other issues will have to be met for every AP1000 that is constructed in England and Wales.

Reference	Description
AP1000-OI01	The capability to include boron recycle in the AP1000 design shall be kept under review and a BAT assessment provided at site-specific permitting to demonstrate whether boron recycling represents BAT.
AP1000-OI02	Detailed arrangements for the hand over between Westinghouse and future operators shall be provided at site-specific permitting, in particular with respect to matters that relate to the use of BAT to minimise radioactive discharges.
AP1000-OI03	The suitability and availability of appropriate mobile equipment for waste which is not compatible with the aqueous radioactive waste system shall be demonstrated at site-specific permitting.
AP1000-OI04	Information relating to the provision of secondary containment for the monitor tanks shall be provided at site-specific permitting.
AP1000-OI05	A detailed and robust justification of options for carbon-14 abatement in radioactive waste discharges shall be provided at site-specific permitting.
AP1000-OI06	Disposability of intermediate level radioactive waste (ILW) following longer term interim storage pending disposal.
AP1000-OI07	Providing evidence at site-specific permitting that the specific arrangements for minimising the disposals of low level waste and intermediate level waste for each site represents BAT.
AP1000-OI08	The monitoring of gaseous, aqueous and solid discharges and disposals of radioactive waste.
AP1000-OI09	Waste from construction activities shall be included in the waste strategy for each site at site-specific permitting.

Annex 3 – AP1000 – ranges of discharges from operating PWRs

A3.1 Introduction

- 786 The White Paper on Nuclear Power (paragraph 2.87) states that ‘The environment agencies will ensure that radiation exposure of members of the public from disposals of radioactive waste, including discharges, are as low as reasonably achievable (ALARA) by requiring new nuclear installations to use the best available techniques (BAT) to meet high environmental standards. This will help ensure that radioactive wastes created and discharges from any new UK nuclear power stations are minimised and do not exceed those of comparable power stations across the world.’
- 787 Industrial processes produce waste, and power generation is no exception. Although nuclear power stations produce far less gaseous waste than conventional power stations, they produce radioactive waste not only in gaseous waste but in liquid and solid waste as well.
- 788 By gaseous waste we mean contaminated air, particulate, gases and vapours released from the reactor or areas where contaminated materials or waste are handled. Liquid radioactive waste may be reactor coolant or other effluent for example, from workshops handling contaminated plant and equipment or change areas. Solid waste may be contaminated having been in contact with reactor plant and equipment.
- 789 This annex covers only low level radioactive waste, it does not cover higher activity waste or irradiated nuclear fuel.
- 790 Since the beginning of nuclear power generation, regulators have required operators of nuclear power stations to take samples, carry out measurements and assessments and determine radioactivity in discharges.
- 791 These measurements and assessments are particularly valuable in determining what the impact on our environment is and whether there is any impact on the food chain.
- 792 Knowing what radioactive waste was discharged from operational stations also allows us to consider whether technology can be used to minimise the amount of waste from new stations.
- 793 Radioactivity in waste is not just affected by technology used to minimise it. Improvements in reactor design lead to more efficient burn-up of the nuclear fuel, so less radioactive waste is produced for each unit of electricity generated. Other aspects of reactor design can lead to less radioactivity in waste, for example selecting materials, coolant flow rates and operating conditions.
- 794 This annex is in two parts: firstly a section covering the discharges from operating reactors that are immediate predecessors to the AP1000 to compare the discharges per unit of electricity generated with those claimed for the AP1000; secondly a wider view of a larger number of operating PWRs that compares the long-term average discharges normalised to installed electrical capacity. Some of the average data in the second section includes contributions from reactors in the first section.
- 795 Radioactive waste from nuclear power stations contains a wide range of radionuclides. We talk about harm from radioactivity in terms of radiation dose. Some radionuclides are more important than others as they may lead to higher radiation dose. We consider the half life of a radionuclide, its chemical and physical form, its behaviour in the environment and other properties when assessing radiation dose.

A3.2 Radionuclides produced in low level radioactive waste from nuclear power stations

- 796 The major radionuclides or groups of radionuclides produced are:
- a) tritium – a low energy beta emitting radionuclide with a half-life of 12.3 years. It absorbs through pores in the skin as tritiated water;

- b) carbon-14 - a low energy beta emitter with a very long half-life. It can be taken up by crops and marine life;
- c) noble gases – xenon and krypton radionuclides formed by fission (and less importantly argon-41). The highest contributor to the group is xenon-133, with a half-life of 5.25 days. Noble gases are beta and gamma emitters. They neither impact on the food chain nor are absorbed by lungs. The exposure route to members of the public is directly by radiation from the plume. This is a trivial route of exposure for discharges from water cooled reactors;
- d) iodines – several radionuclides of iodine are formed during nuclear fission. The most important of these is iodine-131, with a relatively short half-life of eight days: it is both a beta and gamma emitter. The main pathway for dose to the public is by being deposited on crops and then eaten, for example deposited on grass, grazing by cows, then consumption of contaminated milk;
- e) other radionuclides – we have grouped other radionuclides produced together as they tend to be minimised by the same techniques (for example, filtration or ion exchange) and are usually measured as a group using a gross activity method. The most important of these are:
 - i) cobalt-60 and cobalt-58 - these are activated corrosion products with half-lives of 5.3 years and 71 days respectively. They are both beta and gamma emitters.
 - ii) caesium-137 and caesium-134 - these are fission products with half-lives of 30 and two years respectively. They are both beta and gamma emitters.
- f) cobalt-60 is the most significant of these radionuclides in terms of radiation dose to the public from liquid discharges from water cooled reactors. Cobalt-60 has a medium length half-life. It can accumulate in marine sediments on which, fish and shellfish live and pass to humans who consume seafood;
- g) a number of other activated corrosion products can also be produced in less significant amounts. These radionuclides include iron-55 and nickel-63.

A3.3 Section One – Discharges from operating predecessor reactors

797 We commissioned Areva Risk Management Consulting Ltd to research records of radioactive waste disposal from comparable operating nuclear power stations worldwide. The results of this work are contained in science reports SC070015/SR1 and 2.

A3.3.1 What the science report covered

798 The science report researched information on four types of candidate reactor:

- AP1000 submitted by Westinghouse;
- Evolutionary pressurised reactor (EPR) submitted by EDF and AREVA;
- Economic simplified boiling water reactor, ESBWR submitted by GE-Hitachi;
- ACR-1000, submitted by AECL.

799 This annex covers the AP1000 only.

800 It provides discharge information from six operating nuclear power stations - including Sizewell B - that are predecessors to the AP1000 design.

801 Where discharge information was not provided directly by operators of those nuclear-power stations, it was obtained indirectly from the nuclear regulators in the country where they were operating or from reports from the United Nations Scientific Committee on the Effects of Atomic Radiation (UNSCEAR). The report presents the discharges having normalised them to gigabecquerels per gigawatt-hour (GBq/GWeh).

A3.3.2 Discharges from the operational nuclear power stations

802 The discharge data for the predecessor nuclear power stations allows us to compare and extrapolate so we can predict discharges from candidate nuclear power stations. It is important not to draw comparisons too closely as there are many uncertainties in the datasets. The largest uncertainty is probably differences in sampling and measurement techniques that the predecessor stations evolved and use – these are general improvements in sampling equipment and instrument sensitivity, leading to more accurate measurements being carried out.

A3.3.2.1 Gaseous discharges

Table 1: Releases of gaseous waste from operating station

	Years	Gaseous discharge				
		Tritium (MBq/GWeh)	Carbon-14 (MBq/GWeh)	Noble Gases (MBq/GWeh)	Iodines (kBq/GWeh)	Fission and activation products (kBq/GWeh)
Predecessor actual – AP1000	'90-'06	2 – 1000	20 - 30	0.6 - 900	0.003 - 290	0.06 - 20
	'00-'04	6 – 30	0.4 – 1000	0.003 – 300	0.002 – 60	

A3.3.2.2 Aqueous discharges

Table 2: Releases of liquid waste from operating stations

	Aqueous release	
	Tritium (GBq/GWeh)	Other Radionuclides (kBq/GWeh)
Predecessor actual – AP1000	1 – 8	20 – 10000
	2 – 8	40 - 8000

Notes:

- 1) The ranges presented in tables 1 and 2 represent the range of activity in discharges over the seventeen-year reporting period.
- 2) The science report breaks down discharges of liquid waste into two categories – tritium and other.
- 3) Figures have been rounded to one significant figure.

803 We looked at the ranges for two release categories from more recent discharges – noble gas and iodine discharges to air from the AP1000 predecessor stations during the five year period 2000-2004. We chose this period as the data set is well populated and it represents a long enough period after commissioning that operators should be able to control discharges. Surprisingly, the ranges were almost the same as for the seventeen year period.

A3.3.3 AP1000 PREDECESSOR STATIONS

Gaseous tritium

804 Below is a graph of all of the gaseous tritium discharges for AP1000 predecessor stations:-

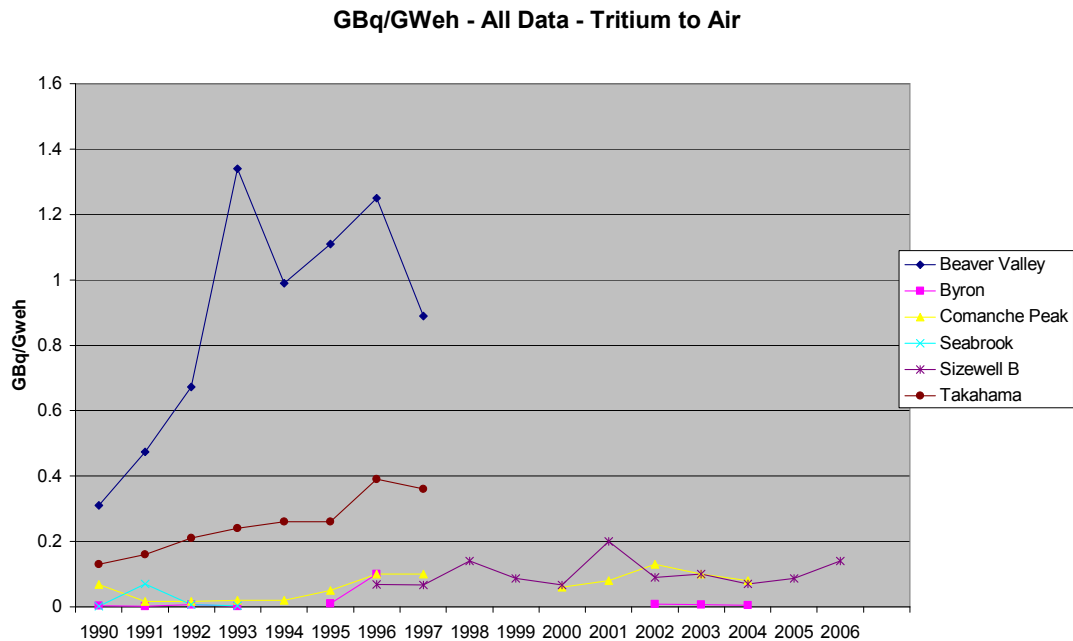

805 The high gaseous releases were mainly from Beaver Valley power station. The science report acknowledged that ‘significantly higher airborne discharges were observed in 1993 and 1996..... a possible cause of this increase in 1993 was the accumulation of gas due to inadequate venting.....etc’

806 It may be prudent to disregard gaseous discharges of tritium from the Beaver Valley power station as they seem unusually high compared to other predecessor stations and we know there has been a period of operation giving rise to particularly high discharges, which might not be relevant to new build stations.

807 **Takahama** the discharges from Takahama seem significantly higher than the remaining predecessor stations. The science report gives no insight as to why that should be.

808 The graph indicates that 75 per cent of discharges were in the range 0.05 - 0.2 GBq/GWeh. This is a comparatively narrow range.

Noble gases

809 Below is a graph of all the gaseous noble gas discharges for AP1000 predecessor stations: -

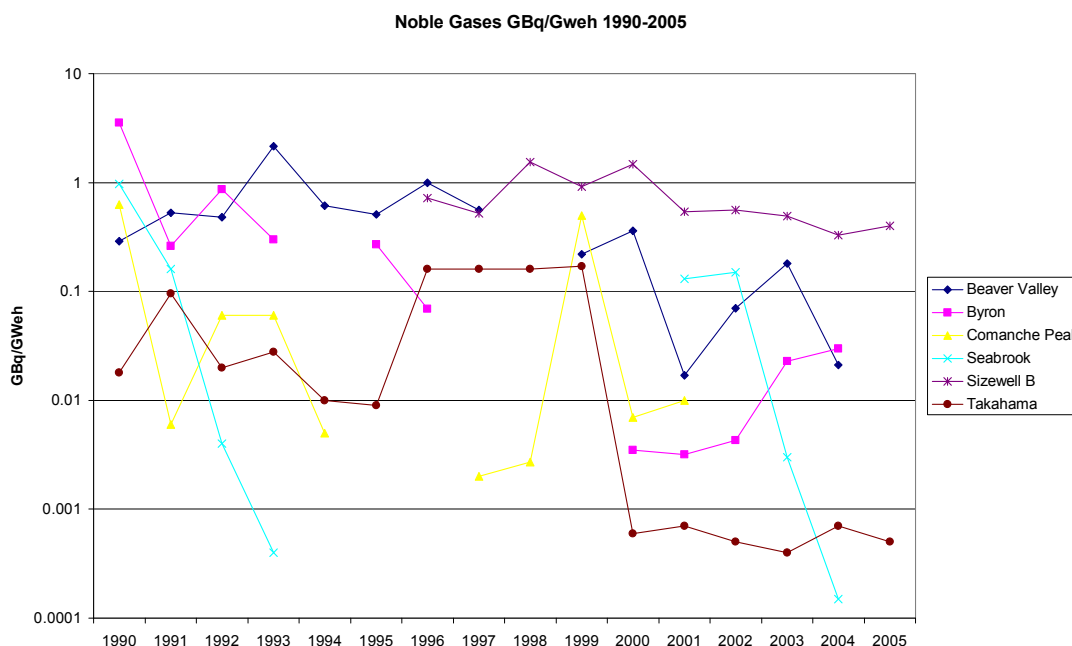

810 The science report indicates the following unusually high discharges of noble gases:

- 1) Beaver Valley power station as indicated in the previous section;
- 2) peak in airborne discharges from the Byron power station for 1990;
- 3) from the Comanche Peak power station in the period 1990 to 1992;
- 4) from the Sizewell B power station for the years 1998 and 2000.

811 Disregarding these unusually high discharges, predecessor stations have operated within a very wide range of discharges of noble gases to air from very low levels up to 1 GBq/GWeh.

812 Recent discharges will be a better indicator for future discharges: 75 per cent of the discharges reported in the last five years are in the range 0.5 – 200 MBq/GWeh - this may be a reasonable range to expect new build stations to better.

Carbon-14

813 The science report found only data for gaseous discharge of carbon-14 from Sizewell B.

MBq/GWeh - Sizewell B - Carbon-14 to Air

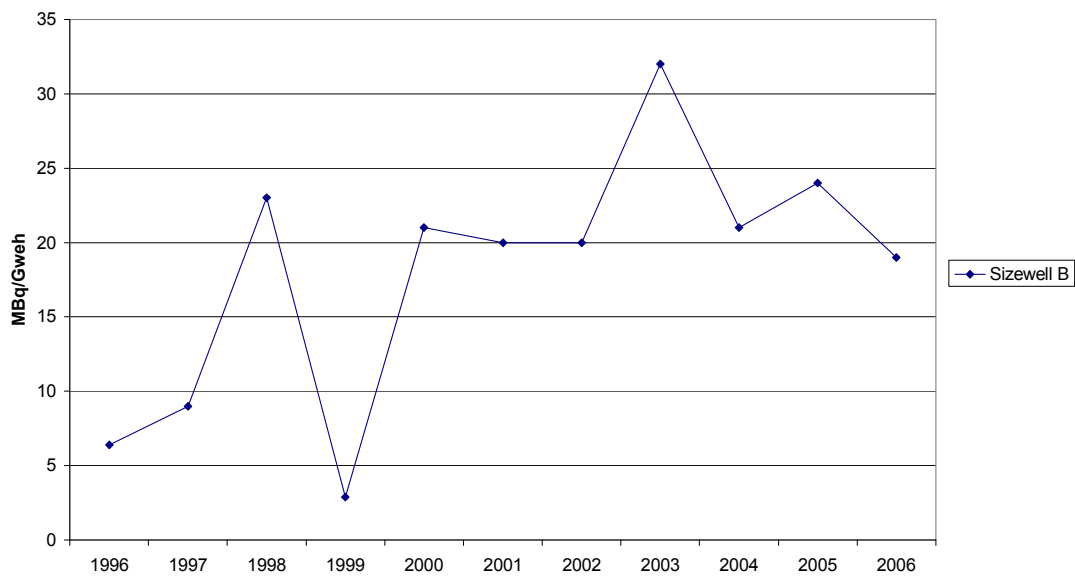

814 This indicates that the Sizewell B power station operated with 75 per cent of carbon-14 discharges in the range: 8-25 MBq/GWeh.

Iodine -131

815 Below is a graph of all the iodine-131 gaseous discharges for AP1000 predecessor stations:

Iodine -131 to Air

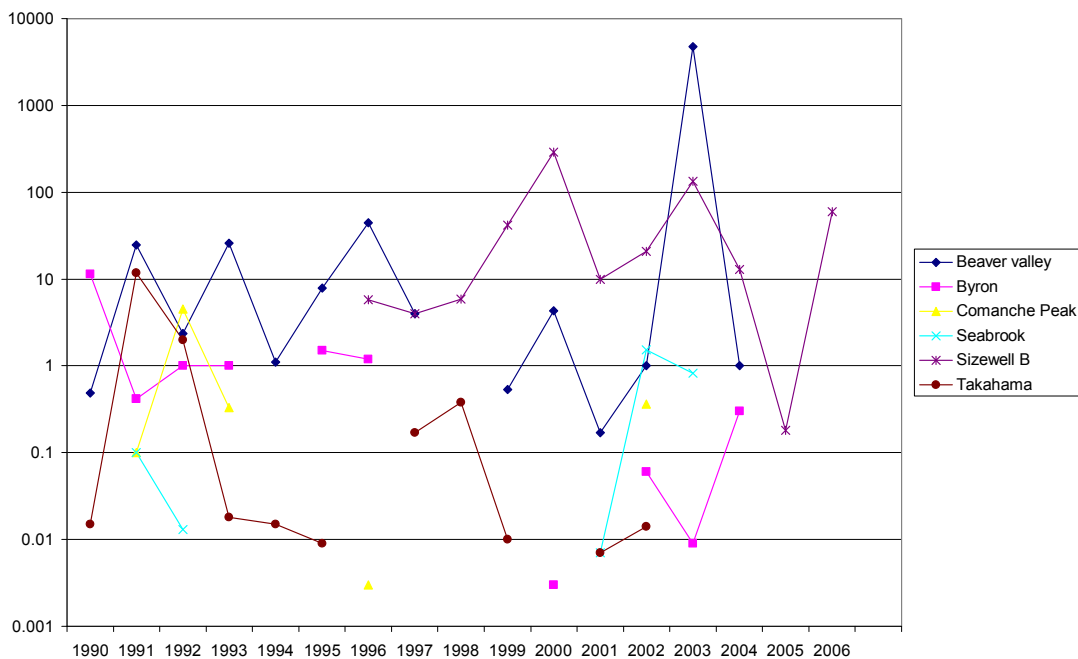

816 The science report excluded the very high discharge from Beaver Valley. The remaining data is extremely variable. Sets of discharge data are largely incomplete for all stations.

817 75 per cent of the reported discharges are within the range 0.01 – 30 kBq/GWeh.

Gaseous particulate

818 Below is a graph of all the particulate gaseous discharges for AP1000 predecessor stations:

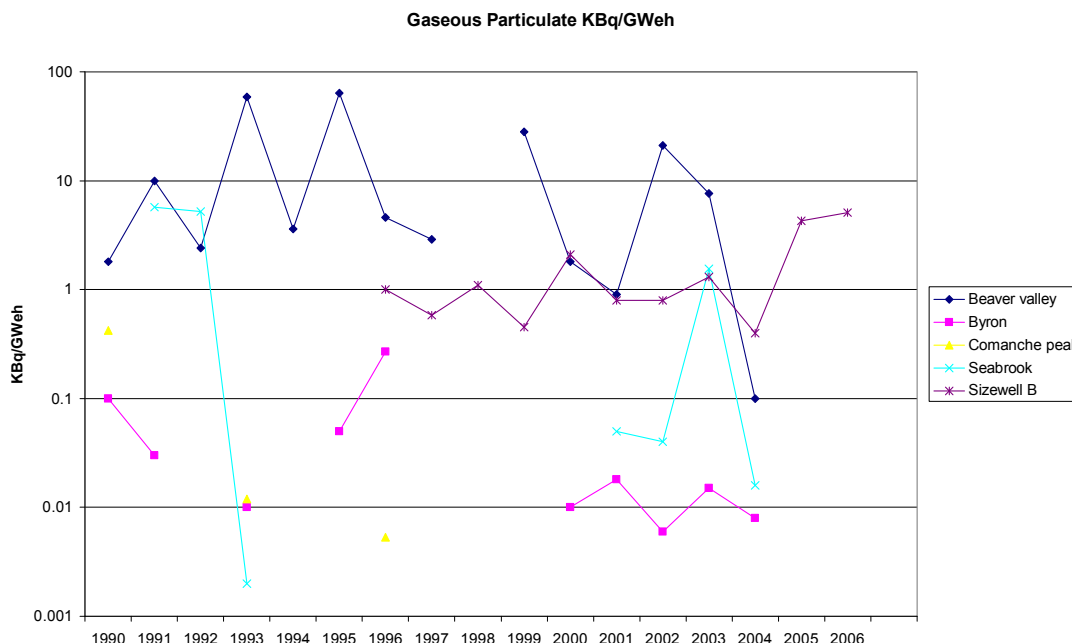

819 The science report indicates no unusually high discharges of gaseous particulate.

820 There is no data for Takahama and limited data for Comanche Peak.

821 The data for Sizewell B power station indicates an average of 1 kBq/GWeh and much higher discharges from Beaver Valley power station.

822 75 per cent of the reported discharges are within the range 0.01 – 5 kBq/GWeh.

Aqueous tritium

823 Below is a graph of all the liquid tritium gas discharges for AP1000 predecessor stations:

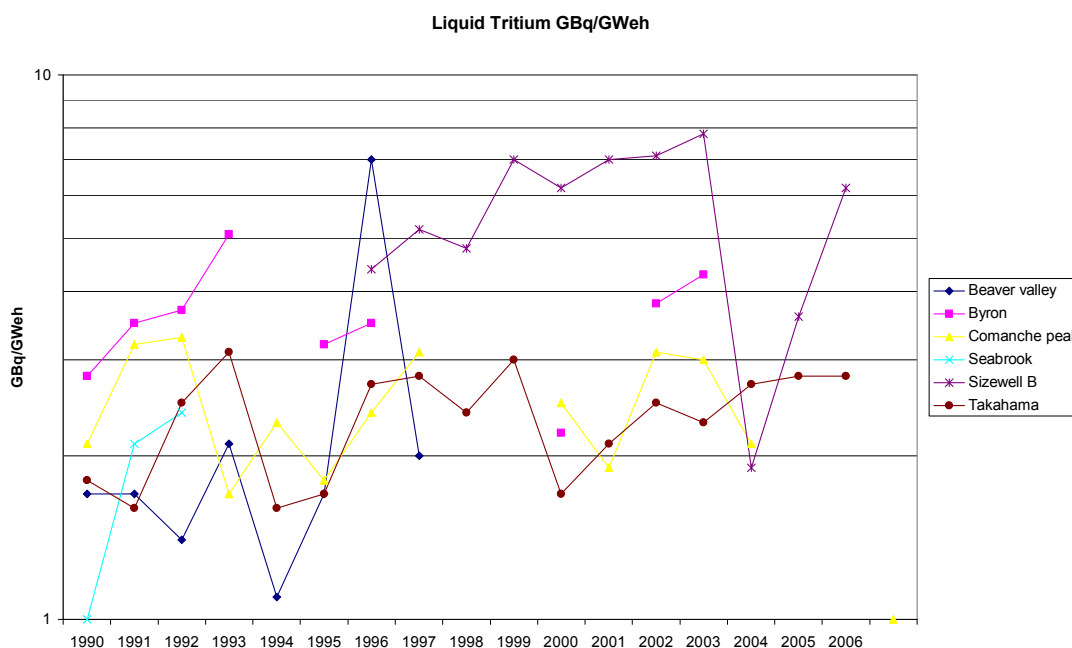

824 This indicates that 75 per cent of the discharges are within the range 2 - 4 GBq/GWeh.

1. The particularly high discharge from Beaver Valley in 1996 is attributed to a particular event as mentioned in the science report.
2. Sizewell B discharges are relatively very high for most years.

Aqueous Other radionuclides

825 Below is a graph of all the liquid other radionuclides for AP1000 predecessor stations:

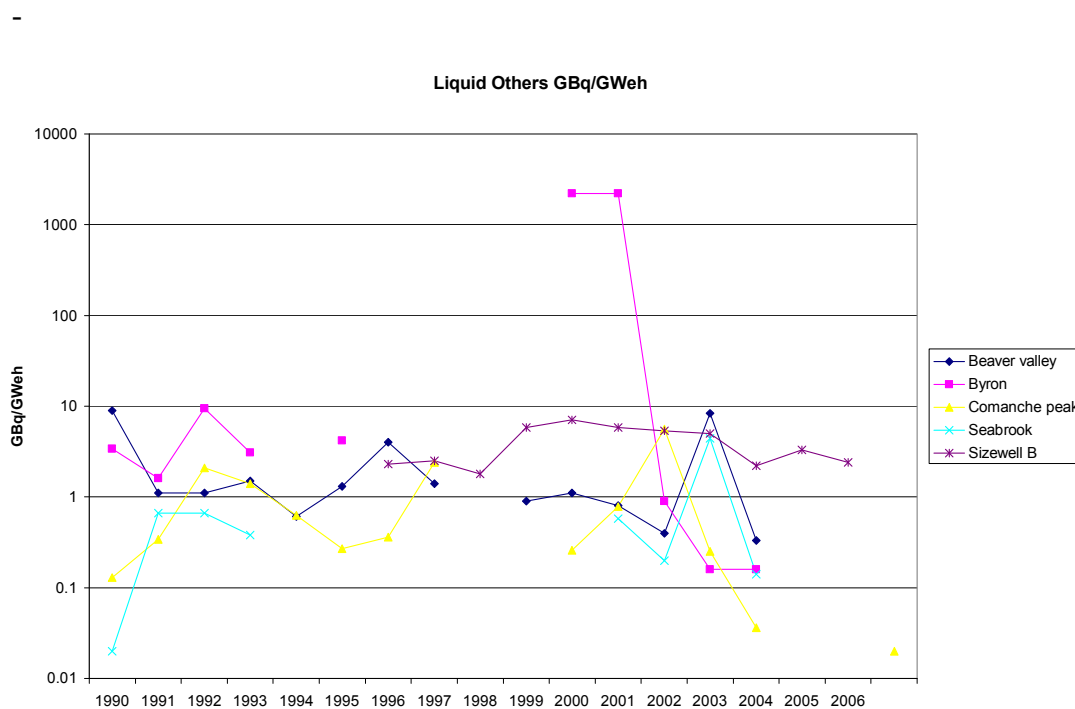

826 This indicates that 75 per cent of the discharges are within the range 0.5 - 10 GBq/GWeh.

A3.4 Section Two - Average discharges from the wider PWR sector

A3.4.1 Atmospheric discharges

Tritium - Atmospheric discharge

827 From our examination of historic discharges from European PWRs (References 1 and 3) and US PWRs (Reference 2) operating over the last ten to 15 years we conclude that there is a normal operating range of 100 to 3600 GBq per annum for a 1000 MWe power station. At the maximum of this range, the dose to the most exposed individual under conservative generic conditions would be less than 0.2 μ Sv. The generalised derived limits (GDL) used in the graph represent the values of discharge leading to doses to the most exposed individual of 1000, 500, 300, 150, 10 and 5 μ Sv.

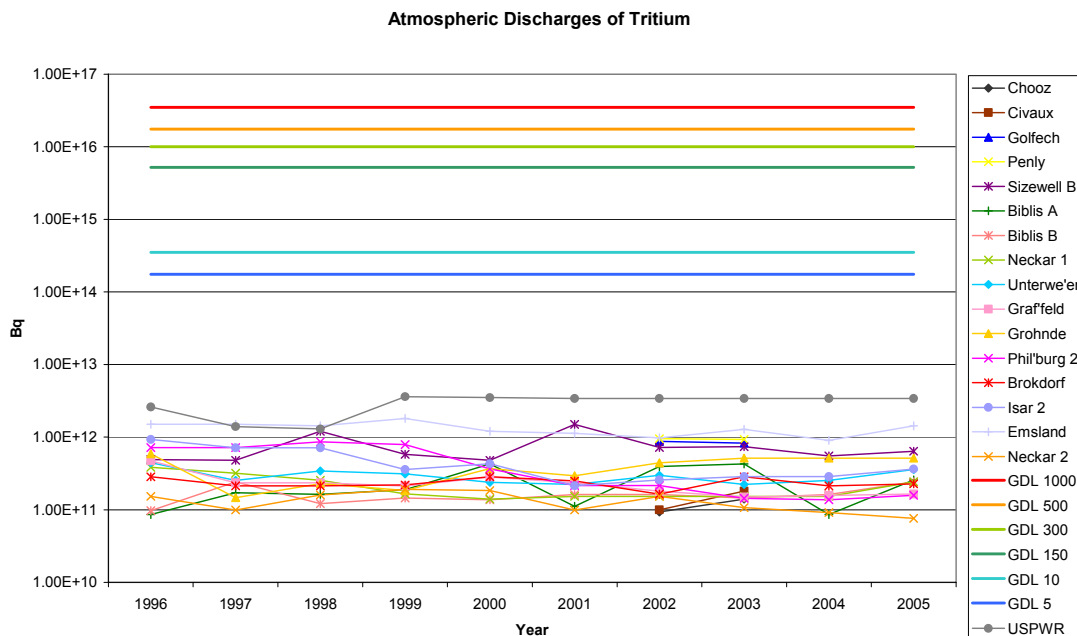

Carbon-14 - Atmospheric discharge

828 From our examination of historic discharges from European PWRs operating over the last 10 to 15 years (see the graph below), we conclude that there is a normal operating range of 40 to 530 GBq per annum for a 1000 MWe power station. At the maximum of this range, the dose to the most exposed individual under conservative generic conditions would be less than 3 μ Sv.

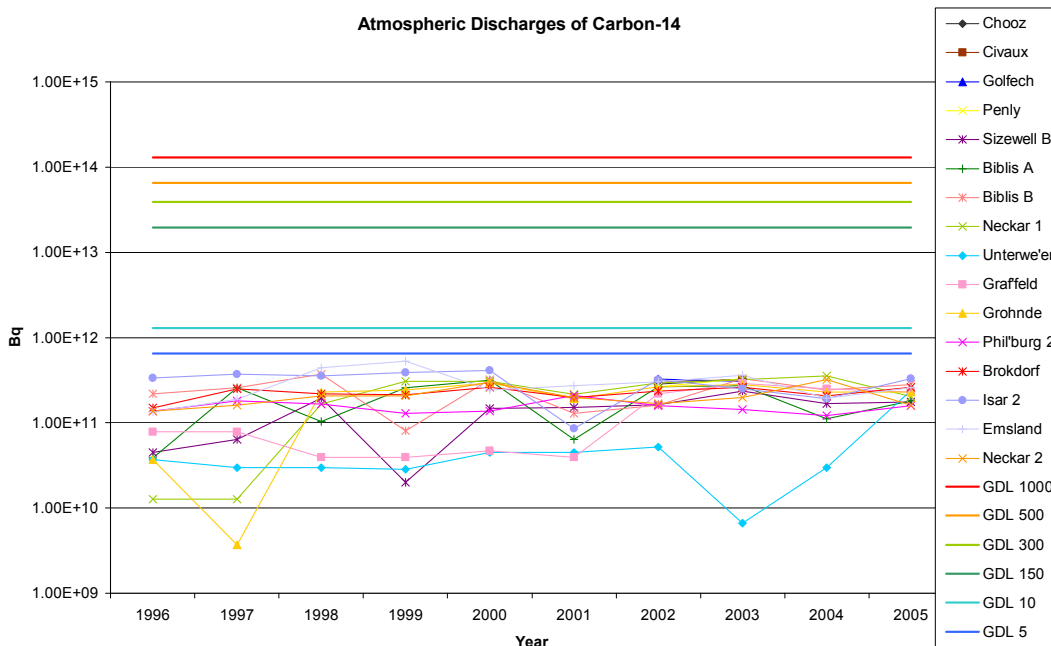

Noble gases - Atmospheric discharge

829

From our examination of historic discharges from European and US PWRs operating over the last 10 to 15 years (see graph below), we conclude that there is a normal operating range of 100 to 10 000 GBq per annum for a 1000 MWe power station. At the maximum of this range, the dose to the most exposed individual under conservative generic conditions would be less than 0.05 µSv (assuming all discharges comprise the most restrictive species krypton-85 - used for the GDL values in the graph).

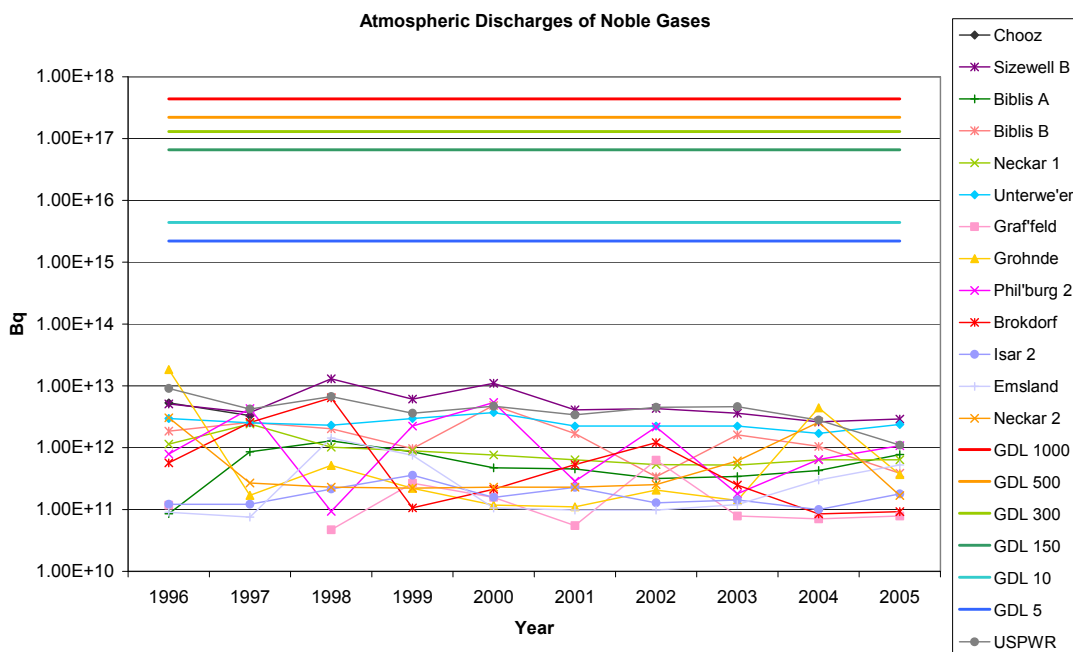

Iodine - Atmospheric discharge

830

From our examination of historic discharges from European and US PWRs operating over the last 10 to 15 years, we conclude that in terms of discharge to atmosphere of iodine-131 there is a normal operating range of from less than 1 to 2000 MBq per annum for a 1000 MWe power station. At the maximum of this range, the dose to the

most exposed individual under conservative generic conditions would be less than 0.5 μSv (assuming all discharge to iodine-131).

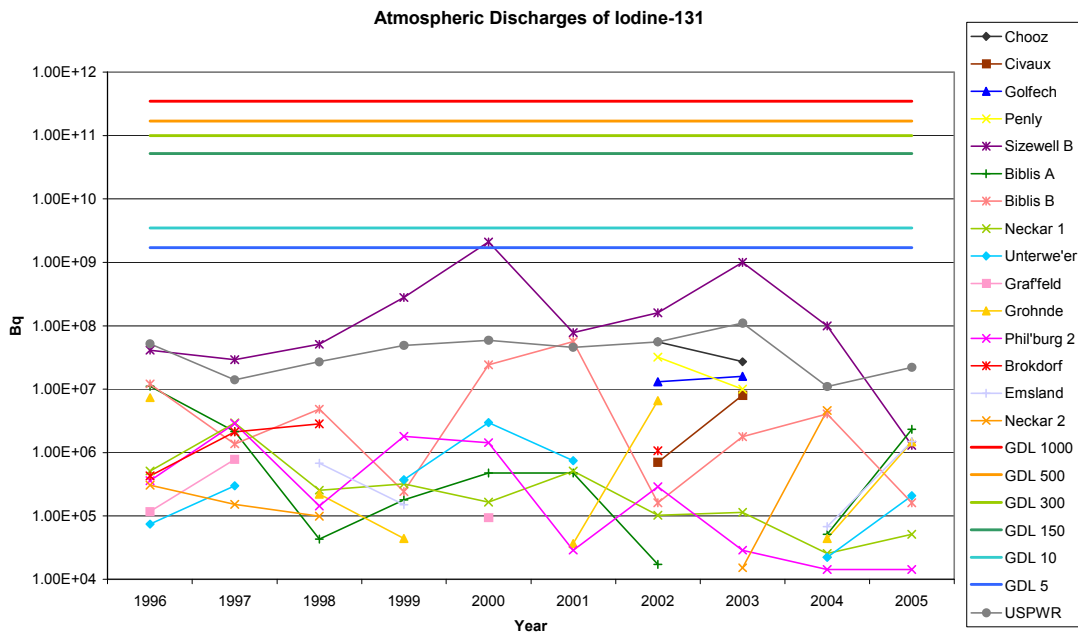

Fission and activation products - Atmospheric discharge

831 From our examination of historic discharges from European and US PWRs operating over the last 10 to 15 years, we conclude that in terms of discharge to atmosphere of fission and activation products there is a normal operating range of from less than one to 1000 MBq per annum for a 1000 MWe power station. At the maximum of this range, the dose to the most exposed individual under conservative generic conditions would be less than 5 μSv (assuming all discharge comprises caesium-137).

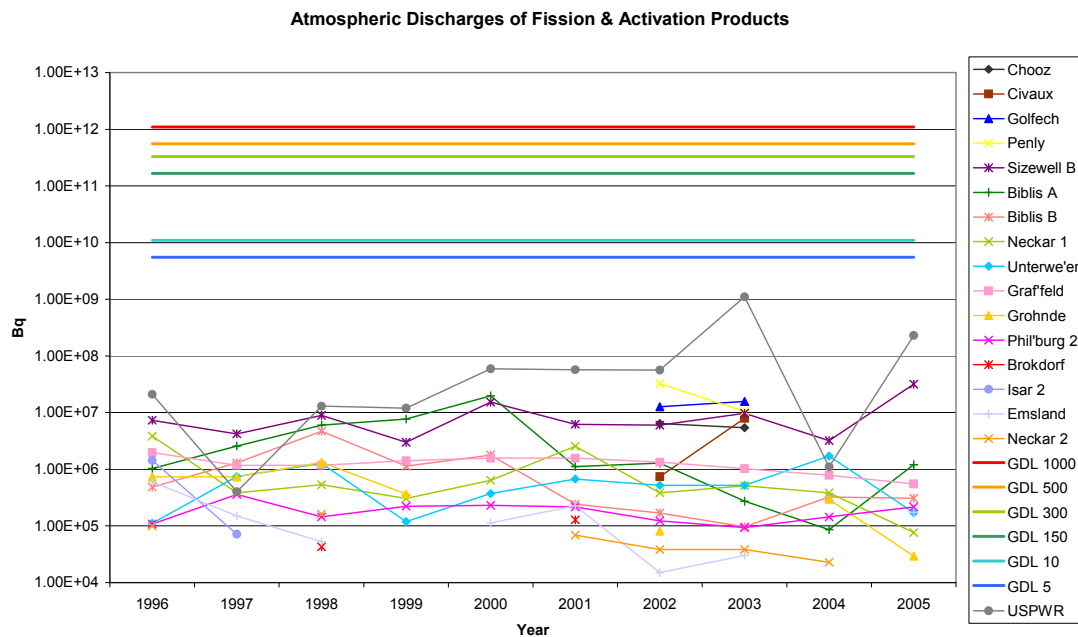

A3.4.2 Aqueous discharges

Tritium - aqueous discharge

832 From our examination of historic discharges from European and US PWRs operating over the last 10 to 15 years, we conclude that in terms of discharge to water of tritium there is a normal operating range of 2000 to 30 000 GBq per annum for a 1000 MWe power station. At the maximum of this range, the dose to the most exposed individual under conservative generic conditions would be less than 0.05 μ Sv.

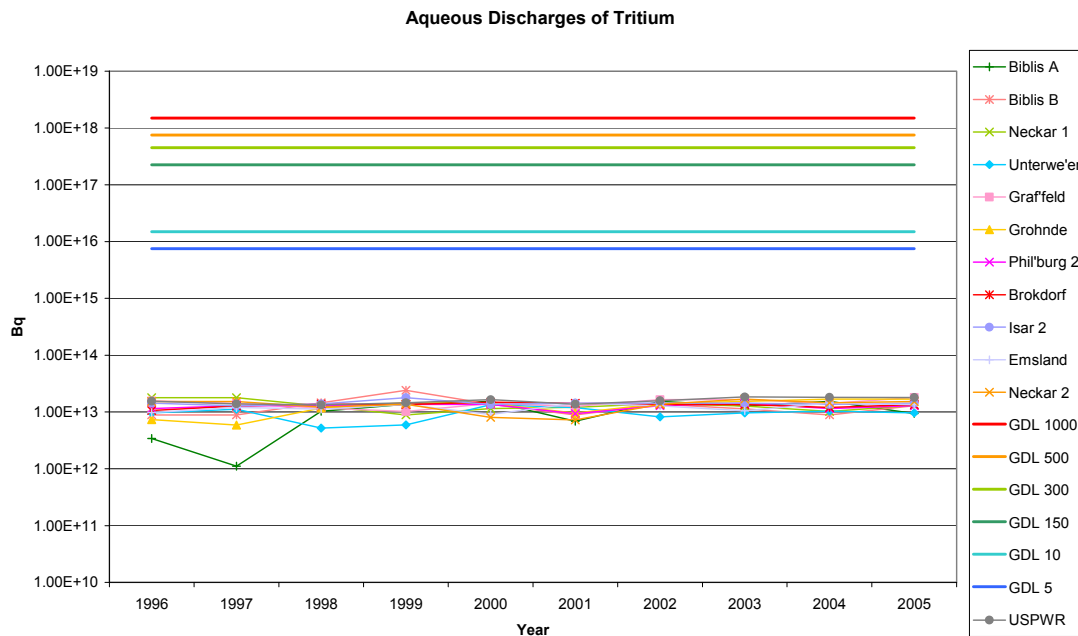

Carbon-14 - Aqueous discharge

833 From our limited information about PWRs operating over the last 10 to 15 years, we conclude that in terms of discharge to water of carbon-14 there is a normal operating range of 3 to 45 GBq per annum for a 1000 MWe power station. At the maximum of this range, the dose to the most exposed individual under conservative generic conditions would be less than 20 μ Sv.

Iodine - Aqueous discharge

834 From our limited information about PWRs operating over the last 10 to 15 years, we conclude that in terms of discharge to water of iodines there is a normal operating range of 0.01 to 0.03 GBq per annum for a 1000 MWe power station. At the maximum of this range, the dose to the most exposed individual under conservative generic conditions would be less than 0.00006 μ Sv. Assuming all the iodine is iodine-131.

Fission and activation products - Aqueous discharge

835 From our examination of historic discharges from European and US PWRs operating over the last 10 to 15 years, we conclude that in terms of discharge to water of fission and activation products there is a normal operating range of from less than one to 15 GBq per annum for a 1000 MWe power station. At the maximum of this range, the dose to the most exposed individual under conservative generic conditions would be less than one μ Sv. Assuming all of the discharge is due to caesium-137

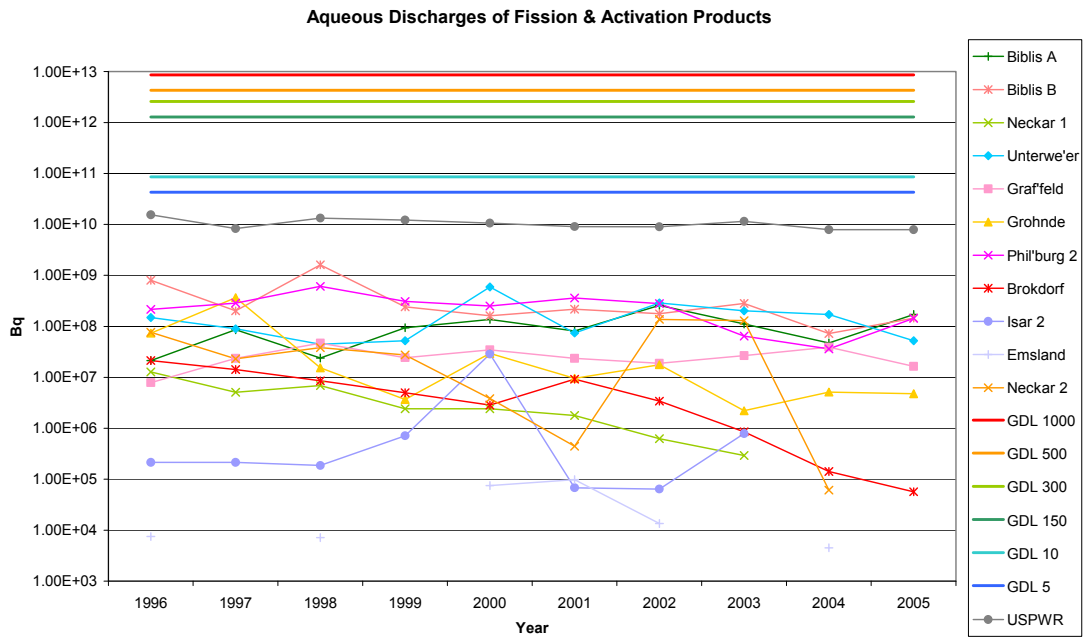

A3.5 Data analysis of normalised discharges from PWR sites

Atmospheric discharges of tritium

Statistic	Normalised to 1000 MWe reactor
Mean discharge from all sites from 1996-2005	592 GBq
Median discharge from all sites from 1996-2005	270 GBq
Standard deviation from all sites from 1996-2005	781 GBq
Standard error of the mean from all sites from 1996-2005	67 GBq
Maximum discharge within one year from a single site (USPWR ⁴ , 1999)	3600 GBq
Minimum discharge within one year from a single site (Neckar 2, 2005)	76 GBq

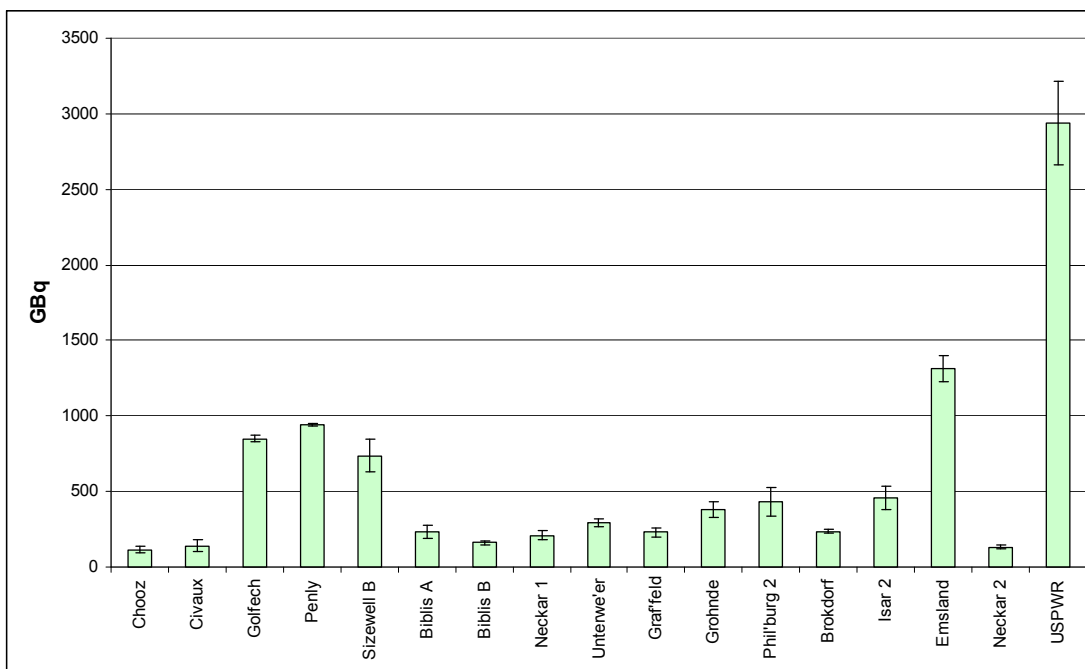

Figure 1: Mean atmospheric discharge of tritium between 1996-2005, for PWR sites, using site-specific data normalised to a 1000 MWe output.

836 The data for atmospheric discharges⁵ of tritium are positively skewed, and therefore, the median value may be a more accurate parameter than the mean, in terms of indicating future discharges. The graph shows that reported discharges lie within a substantial range over several orders of magnitude. USPWRs report substantially greater discharges than the German and French reactors, as well as Sizewell B.

⁴ USPWR data (United States Pressurised Water Reactor) within this report are the average discharges for that year from the USPWR fleet, and not the discharge of a single site.

⁵ Where this section makes reference to 'discharges', this refers to reported discharges which have been normalised to a 1000 MWe reactor, and not actual reported discharges.

Atmospheric discharges of carbon-14

Statistic	Normalised to 1000 MWe reactor
Mean discharge from all sites from 1996-2005	202.61 GBq
Median discharge from all sites from 1996-2005	207.22 GBq
Standard deviation from all sites from 1996-2005	108.14 GBq
Standard error of the mean from all sites from 1996-2005	9.56 GBq
Maximum discharge within one year from a single site (Emsland, 1999)	526.71 GBq
Minimum discharge within one year from a single site (Grohnde, 1997)	3.68 GBq

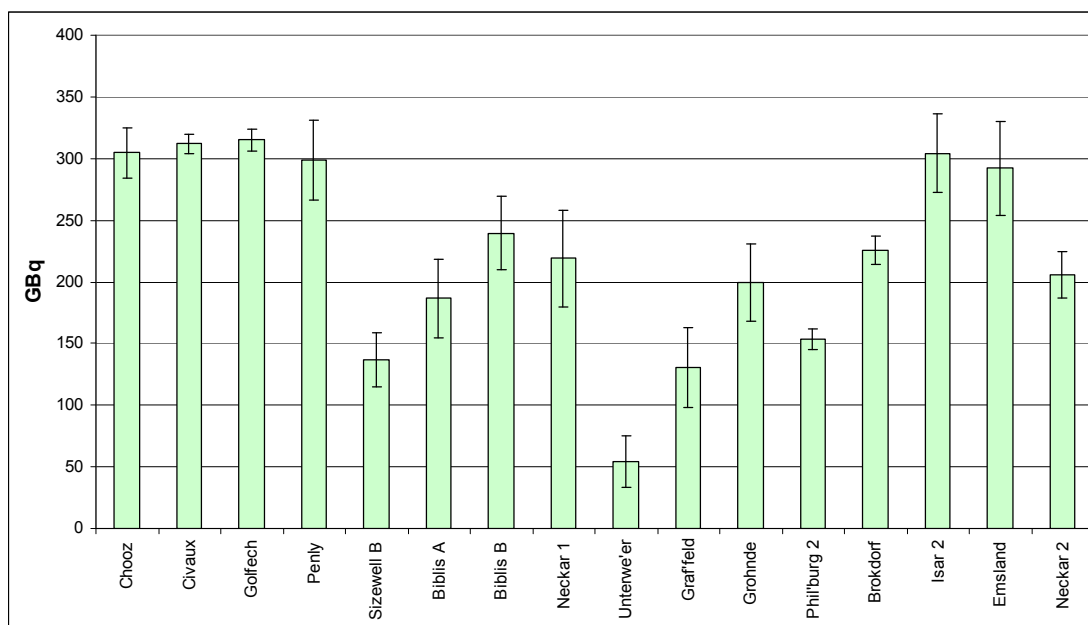

Figure 2: Mean atmospheric discharge of carbon-14 between 1996-2005, for PWR sites, using site-specific data normalised to a 1000 MWe output.

837

The data for atmospheric discharges of carbon-14 are slightly positively skewed, and therefore, the median value may be a more accurate parameter than the mean, in terms of indicating future discharges. The chart and table above show that reported discharges lie within a substantial range over several orders of magnitude. French reactors report greater discharges than the German reactors on average, whilst Sizewell B discharges are on average below mean and median discharges from all sites.

Atmospheric discharges of noble gases

Statistic	Normalised to 1000 MWe reactor
Mean discharge from all sites from 1996-2005	1801 GBq
Median discharge from all sites from 1996-2005	637 GBq
Standard deviation from all sites from 1996-2005	2635 GBq
Standard error of the mean from all sites from 1996-2005	230 GBq
Maximum discharge within one year from a single site (Grohnde, 1996)	18382 GBq
Minimum discharge within one year from a single site (Graf'feld, 1998)	47 GBq

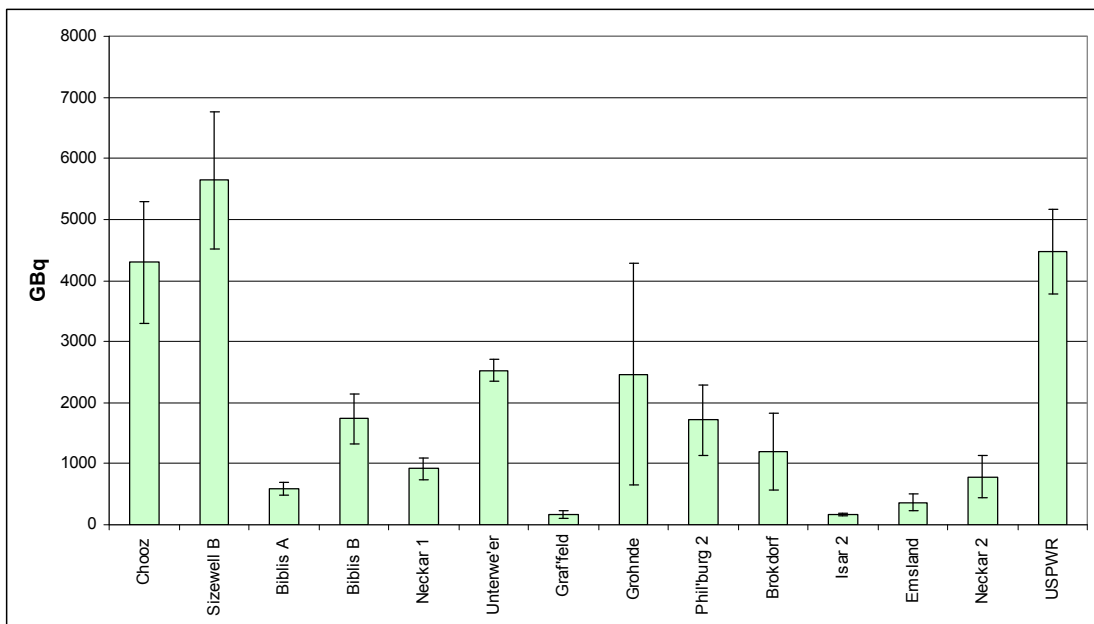

Figure 3: Mean atmospheric discharge of noble gases between 1996-2005, for PWR sites, using site-specific data normalised to a 1000 MWe output.

838

The data for atmospheric discharges of noble gases are positively skewed, and therefore, the median value may be a more accurate parameter than the mean, in terms of indicating future discharges. The graph shows that discharges lie within a broad range. The USPWR, Sizewell B and Chooz sites generally report greater average discharges than the German reactors.

Atmospheric discharges of Iodine-131

Statistic	Normalised to 1000 MWe reactor
Mean discharge from all sites from 1996-2005	0.05 GBq
Median discharge from all sites from 1996-2005	0.0013 GBq
Standard deviation from all sites from 1996-2005	0.24 GBq
Standard error of the mean from all sites from 1996-2005	0.024 GBq
Maximum discharge within one year from a single site (Sizewell B, 2000)	2.10 GBq
Minimum discharge within one year from a single site (Phil'burg, 2005)	0.000014 GBq

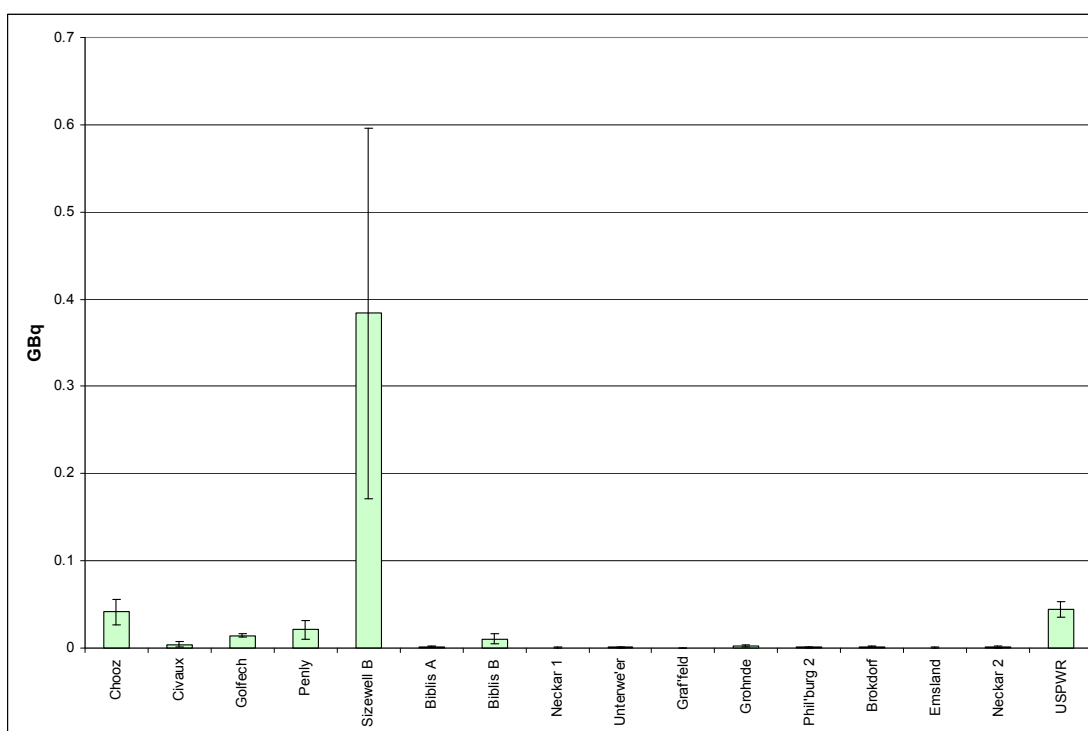

Figure 4: Mean atmospheric discharge of iodine-131 between 1996-2005, for PWR sites, using site-specific data normalised to a 1000 MWe output.

839

The data for atmospheric discharges of iodine-131 are positively skewed, and therefore, the median value may be a more accurate parameter than the mean, in terms of indicating future discharges. The graph shows that average reported discharges from most sites lie well below 0.1 GBq. Average discharges from Sizewell B are substantially greater than the others, which can partially be attributed to two relatively high reported discharges in 2000 and 2003, though discharges from Sizewell B are also generally higher than the other sites. The German reactors typically report lower discharges than the USPWR and French reactor sites.

Atmospheric discharges of fission and activation products

Statistic	Normalised to 1000 MWe reactor
Mean discharge from all sites from 1996-2005	0.016 GBq
Median discharge from all sites from 1996-2005	0.00074 GBq
Standard deviation from all sites from 1996-2005	0.11 GBq
Standard error of the mean from all sites from 1996-2005	0.010 GBq
Maximum discharge within one year from a single site (USPWR, 2003)	1.10 GBq
Minimum discharge within one year from a single site (Emsland, 2002)	0.000015 GBq

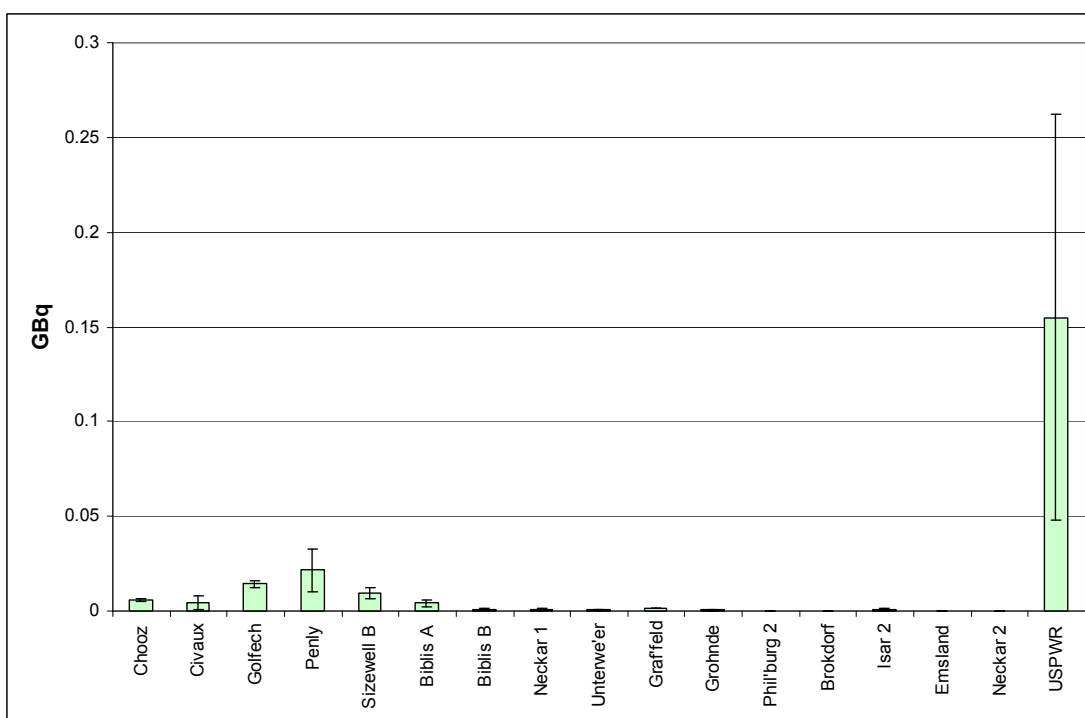

Figure 5: Mean atmospheric discharge of fission and activation products between 1996-2005, for PWR sites, using site-specific data normalised to a 1000 MWe output.

840

The data for atmospheric discharges of fission and activation products are positively skewed, and, therefore, the median value may be a more accurate parameter than the mean, in terms of indicating future discharges. The graph and table above show that reported discharges lie within a substantial range over several orders of magnitude. The USPWR sites on average report substantially greater discharges than all other sites. The German reactors generally perform better than the French reactors and Sizewell B, in terms of discharges of fission and activation products to the atmosphere.

Aqueous discharges of tritium

Statistic	Normalised to 1000 MWe reactor
Mean discharge from all sites from 1996-2005	12817 GBq
Standard deviation from all sites from 1996-2005	3274 GBq
Standard error of the mean from all sites from 1996-2005	299 GBq
Maximum discharge within one year from a single site (Biblis B, 1999)	24194 GBq
Minimum discharge within one year from a single site (Biblis A, 1997)	1114 GBq

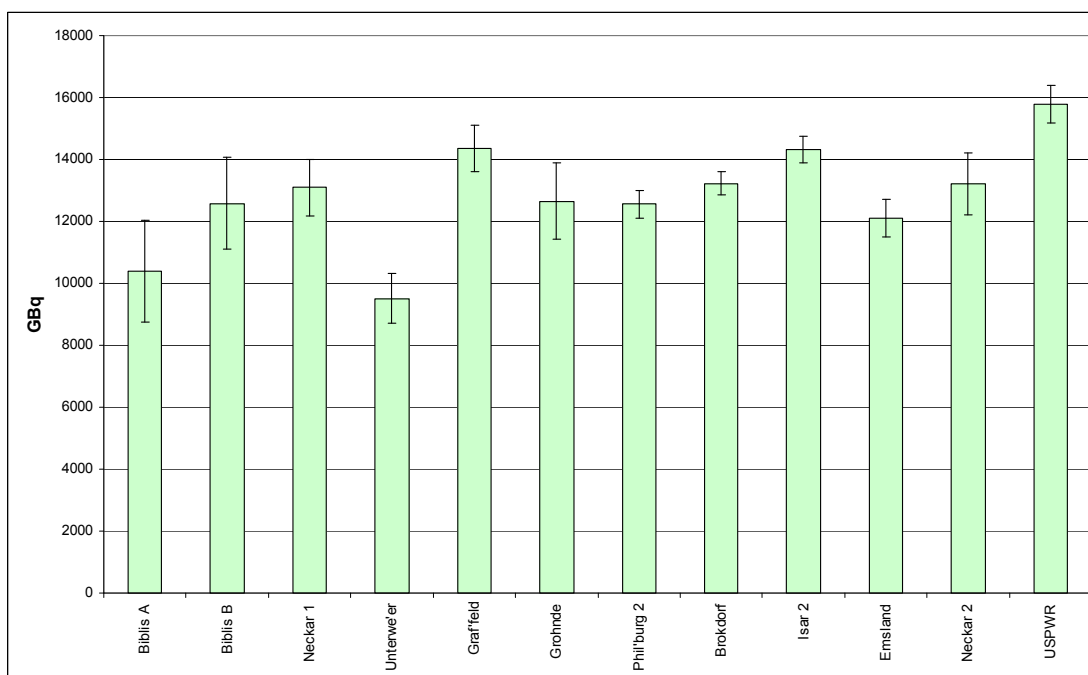

Figure 6: Mean aqueous discharge of tritium between 1996-2005, for PWR sites, using site-specific data normalised to a 1000 MWe output.

841

The data for aqueous discharges of tritium are normally distributed, and, therefore, the mean value may be a useful indicator of future discharges. The graph shows that reported discharges are relatively stable across all sites, with a relatively small range of discharges and a small margin of error. The USPWR sites on average report slightly greater discharges than the German reactor sites.

Aqueous discharges of fission and activation products

Statistic	Normalised to 1000 MWe reactor
Mean discharge from all sites from 1996-2005	1.05 GBq
Median discharge from all sites from 1996-2005	0.04 GBq
Standard deviation from all sites from 1996-2005	3.10 GBq
Standard error of the mean from all sites from 1996-2005	0.29 GBq
Maximum discharge within one year from a single site (USPWR, 1996)	15.50 GBq
Minimum discharge within one year from a single site (Emsland, 2004)	0.0000045 GBq

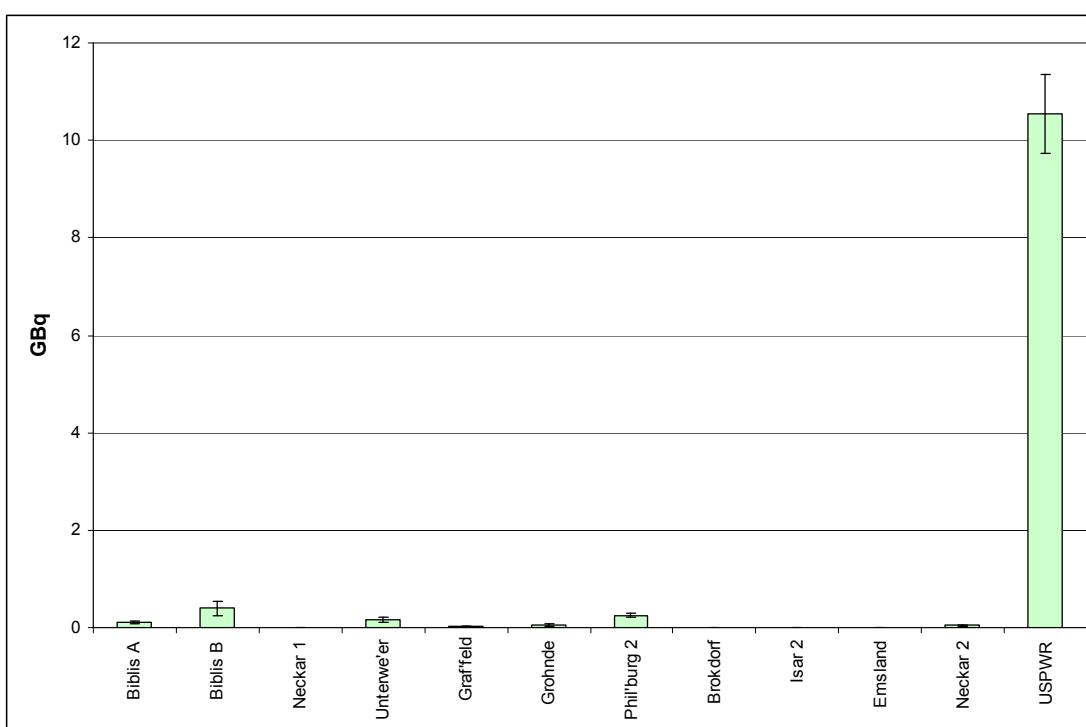

Figure 7: Mean aqueous discharge of fission and activation products between 1996-2005, for PWR sites, using site-specific data normalised to a 1000 MWe output.

842

The data for aqueous discharges of fission and activation products are positively skewed, and, therefore, the median value may be a more accurate parameter than the mean, in terms of indicating future discharges. The graph and table above show that reported discharges lie within a substantial range over several orders of magnitude. The USPWR sites consistently report substantially greater discharges than the German sites, with a mean discharge of over 10 GBq.

Annex 3 References:

1. Berichte der Strahlenschutzkommission (SSK) des Bundesministeriums für Umwelt, Naturschutz und Reaktorsicherheit – Heft 58 (2009) Bewertung der epidemiologischen Studie zu Kinderkrebs in der Umgebung von Kernkraftwerken (KiKK-Studie) – Wissenschaftliche Begründung zur Stellungnahme der Strahlenschutzkommission“
2. Radiological Effluents Released by US Commercial Nuclear Power Plants from 1995-2005. Health Physics December 2008, Volume 95, Number 6
3. Environment Agency Science Reports SC070015/SR1 and 2.

Annex 4 – Sources and types of radioactivity in pressurised water reactors

Introduction

- 843 At the start of its life a pressurised water reactor (PWR) has only a fairly small amount of radioactivity inside it, due to its core of uranium oxide fuel. The quantity depends on two factors:
- 844 a) the total quantity of uranium fuel in the core - typically 100 tonnes;
 - b) the level of enrichment of the uranium in the isotope uranium-235 - typically around two to three per cent, but up to a maximum of five per cent.
- 844 Once it starts operation the nuclear reactions going on in the uranium in the fuel produce heat and increased radioactivity in the form of fission products - two or more 'new' chemical elements from each uranium atom that has split - and 'new' chemical elements that are heavier than uranium - transuranic or actinide elements - that are formed by uranium atoms (strictly the centre part of the atom or 'nucleus') absorbing one or more neutrons without splitting. Fission products and transuranic elements are produced and retained within the uranium oxide fuel. Neutrons that escape from the fuel without causing fission or creating transuranic elements can react with other atoms in the reactor core - or passing through it - to form 'new' elements. These are called activation products.
- 845 This annex describes the types of new radioactive species and the way that they are formed and covers:
- a) fission products;
 - b) transuranic elements;
 - c) activation products.
- 846 Some radioactive elements can be formed by more than one of these mechanisms.

Fission products

- 847 The fission process can be explained using the 'liquid drop' model of an atom's core: the nucleus. In normal circumstances, the nucleus is nearly spherical in shape like a water droplet. After the absorption of a neutron, the nucleus will be in an excited state and start to oscillate and become distorted. If the oscillations cause the nucleus to become shaped like a dumbbell, the repelling electrostatic forces (or charges) will overcome the shorter-range nuclear forces and the nucleus will split. The heaviest nuclei are easily fissionable because they require only a small distortion from the spherical shape to allow the electric forces to overcome the nuclear force to break the nucleus.
- 848 Each fission produces two or more smaller nuclei - fission products - and neutrons, gamma rays and beta particles. All of these have considerable energy for their size, which is given up as heat when they strike nearby atoms in the uranium oxide fuel. Heat from fission is measured in the unit electron-volt (eV) or megaelectron-volt (MeV) - one million electron-volts.
- 849 In a single fission of a uranium nucleus approximately 200 MeV of useful energy is produced as heat. It would take nearly 3000 million million - 3×10^{15} - fissions to produce enough heat to boil enough water for a mug of tea at the same time converting about one millionth of a gram (one microgram - μg) of uranium into fission products.
- 850 Many fission products are themselves radioactive and have some general features in common:

- a) they undergo radioactive decay by emitting a beta particle;
 b) the most common atomic mass numbers are grouped near 95 and 140.

- 851 The amount of each fission product arising in a reactor is called the 'yield' and is expressed as a percentage. For example, strontium-90 and caesium-137 each have a yield of about six per cent, that is they are created in about six per cent of total fissions.
- 852 The vast majority of radioactive fission products have half-lives that are much shorter than the uranium in the fuel (that is they undergo more radioactive decays per second than the same mass of uranium would have done). This means that most fission products are much more radioactive than the original uranium.
- 853 A typical modern nuclear reactor generates 1250 megawatts of electricity (MWe) and operates at a thermal efficiency of 33 per cent (that is 33 per cent of the energy from fission is converted to electricity). The total energy required to operate at full power for a year would need the heat raised by 3.7×10^{27} (3700 million million million million) fissions. This would consume nearly 1.5 tonnes of uranium. The fission yield for caesium-137 is about six per cent so about 50 kilograms (kg) would be produced from the fissioning of the uranium. The radioactivity of the original uranium was about 40 gigabecquerels (GBq). The radioactivity of 50 kg of caesium-137 is about 160 000 terabecquerels (TBq) - or about four million times as great. Caesium-137 has a half-life of about 30 years, so it will take some 660 years for it to fall below that of the original uranium in the fuel.
- 854 The more important fission products are listed in Table 1 with their yields, and half-lives.

Table 1. Fission products

Fission product nuclide	Symbol	Yield % (Total U-235)	Half-life
Tritium	H-3	0.01	12.3 y
Krypton-85	Kr-85	0.286	10.7 y
Krypton-85m	Kr-85m	1.303	4.5 h
Strontium-90	Sr-90	5.73	28.8 y
Zirconium-95	Zr-95	6.5	64 d
Niobium-95	Nb-95	6.5	35 d
Molybdenum-99	Mo-99	6.1	2.7 d
Technetium-99	Tc-99	6.1	210 000 y
Ruthenium-103	Ru-103	3.1	39 d
Tellurium-132	Te-132	4.3	3.2 d
Iodine-129	I-129	0.7	15 000 000 y
Iodine-131	I-131	2.9	8 d
Iodine-133	I-133	6.6	6.6 h
Iodine-135	I-135	6.4	9.1 h
Xenon-133	Xe-133	6.6	5.2 d
Xenon-135	Xe-135	6.6	9 h
Caesium-134	Cs-134	<0.001	2.1 y
Caesium-137	Cs-137	6.2	30 y

Fission product nuclide	Symbol	Yield % (Total U-235)	Half-life
Barium-140	Ba-140	6.3	12.8 d
Lanthanum-140	La-140	6.3	1.7 d
Cerium-141	Ce-141	5.9	32 d
Praesodymium-144	Pr-144	5.5	17 m
Neodymium-144	Nd-144	5.5	2.4 y
Neodymium-147	Nd-147	2.2	10.98 d
Promethium-149	Pm-149	1.05	2.2 d
Promethium-151	Pm-151	0.42	1.18 d

Actinides/transuranics

855 Where the absorption of a neutron in a uranium atom is achieved without the energy to distort the nucleus enough to cause it to fission, a new, heavier nucleus is formed. These are called actinides or transuranic elements. The most common of these are the isotopes of plutonium, americium and curium. Of course, the absorption of further neutrons will lead to either fission or the creation of heavier-still nuclei and so on. In summary, the heat that is ultimately used to raise steam to drive the turbine to make electricity comes from fission; fission occurs in uranium and other heavy atoms created in the fuel; other heavy atoms that will not fission remain in the fuel as actinides/transuranics. It is not possible to use every fissionable atom within the current types of commercial reactor for reasons connected to nuclear physics, and the original fuel must be replaced by fresh uranium when the former has undergone as many fissions as practicable; the old fuel is described as 'spent'. The amount of heat energy extracted from the fuel is described as 'burn-up' and is measured in the percentage of heavy atoms that have fissioned or, more commonly in commercial reactors, in a unit of megawatt-days per tonne of uranium (MWd tU⁻¹) or gigawatt-days per tonne of uranium (GWd tU⁻¹). A reactor generating 1250 MW of electricity; at 33 per cent efficiency; with a core containing 100 tonnes of uranium will require to replace about 30 tonnes of uranium per year. This represents a burn-up of about five percent heavy atoms or 45 000 MWd tU⁻¹.

856 When fresh fuel starts its life in the reactor 100 per cent of the fissions occur in uranium-235 nuclei; the uranium oxide fuel has been enriched in the U-235 isotope in varying quantities - typically two to three per cent but up to five per cent (compared with the natural U-235 content of 0.715 per cent). The enrichment varies across the reactor core, again, for reasons of reactor physics. As the fuel becomes older, other heavy nuclei - uranium-238 and plutonium isotopes created by neutron absorption - make an increasing contribution to the fission process. For example, when fuel enriched to a U-235 content of 2.5 per cent reaches a burn-up of 15 000 MWd tU⁻¹, the U-235 is responsible for half the total fissions. The other major contributors are Pu-239 (37.5 per cent of fissions) and U-238 and Pu-241.

857

Table 2 below contains a list of the important transuranic elements created in a PWR.

Table 2. Transuranic elements

Nuclide	Symbol	Half-life	Decay mode
Neptunium-237	Np-237	2140000 y	α γ
Plutonium-236	Pu-236	2.9 y	α γ
Plutonium-238	Pu-238	87.7 y	α γ
Plutonium-239	Pu-239	24100 y	α γ
Plutonium-240	Pu-240	6560 y	α γ
Plutonium-241	Pu-241	14.4 y	β γ
Plutonium-242	Pu-242	374000 y	α γ
Americium-241	Am-241	433 y	α γ
Americium-242m	Am-242m	141 y	IT γ
Americium-243	Am-243	7360 y	α γ
Curium-242	Cm-242	163 d	α γ
Curium-243	Cm-243	30 y	α γ
Curium-244	Cm-244	18.1 y	α γ
Curium-245	Cm-245	8500 y	α γ
Curium-246	Cm-246	4730 y	α γ
Curium-248	Cm-248	340000 y	α γ
Californium-249	Cf-249	351 y	α γ
Californium-250	Cf-250	131 y	α γ
Californium-251	Cf-251	898 y	α γ
Californium-252	Cf-252	2.65 y	α γ

Activation

858

Some of the neutrons responsible for keeping the fission process going will react with other chemical elements in or passing through the reactor core including:

- the metal cladding surrounding the uranium oxide fuel;
- the structural supporting metal of the core itself;
- the steel pressure vessel;
- the reactor coolant - mostly water but also carrying a variety of chemicals designed to control the fission process by absorbing neutrons; preventing corrosion of fuel cladding and other reactor components; and small quantities of substances arising from the natural erosion and corrosion processes taking place as a result of high pressure hot fluids moving around the circuits.

859

The new substances formed in these reactions are called activation products.

860

Water and any impurities in it are activated only as they pass through the reactor core when there are enough neutrons to cause the reactions. The water only spends a few

seconds in the core, but as the circuits are closed the same water passes through the core over and over again. The rate at which activation products are made depends on a number of things including:

- a) how many atoms of water or impurity are present - sometimes called the parent target atom;
- b) how long the parent atoms spend in the core - flowrate;
- c) how many spare neutrons are present - the neutron flux: neutrons per second passing through one square centimetre. The neutron flux rises as the reactor power increases;
- d) how fast the neutrons are moving - measured as their energy of movement in a quantity called the electron-volt. There is a wide range of neutron speeds but the two important ones for activation products are: fast (F) neutrons with an energy of one megaelectron-volt - MeV - (one MeV is one million electron-volts) - these travel at about $14\,000\text{ km s}^{-1}$; and thermal (T) neutrons with energy of 0.025 eV and a speed of 2200 km s^{-1} ;
- e) the probability that a neutron hitting an atom will cause the reaction of interest. This is a feature of the parent atom and is really a measure of how much of a target area it presents to the neutron so it has a unit related to area - the 'barn' or a fraction of a barn the 'millibarn' - one thousandth of a barn. A barn is equal to 1×10^{-24} of a square centimetre. An atom presenting an area or cross-section of 50 barns is ten times more likely to be activated than an atom of five barns when faced with a neutron of the same energy.

861 Note that other types of radiation can cause activation - for example, protons, gamma rays etc. - and the rate of production will depend on similar factors to the five above.

862 Activation products have three main points of interest:

- a) their half-life - how long will it take for half of the atoms to decay;
- b) the type of radiation - and its energy - they emit when they decay;
- c) their chemical properties - that is will they react chemically and stick to other atoms either in the core, adjoining circuits or coolant clean-up and treatment plant?

863 The process of activation can be complex but may be simplified and written down in shorthand. The key pieces of information are:

- a) what is the target?
- b) how much of the target is there?
- c) what types of radiation are involved? Normally one type - a neutron, say - penetrates the target atom and another type - a gamma ray - escapes.
- d) what is the probability of reaction or cross-section of the target and is this for fast or thermal neutrons?
- e) what new radionuclide is formed?
- f) what is its half-life?
- g) what type of radiation does it emit when it decays?

864 Using the activation of the stable atom carbon-13 to produce radioactive carbon-14 as an example the shorthand is as follows:

C-13(n, γ)C-14 - 1.11% - 0.9 mb(T) - 5730 years - β

In words: the target is carbon-13; it makes up 1.11 per cent of all carbon in the natural world; it is struck by a neutron and gives off a gamma ray; the probability of the reaction is 0.9 millibarns with a thermal neutron; the activation product is carbon-14 with a half-life of 5730 years emitting only beta radiation as it decays.

865

Some of the important activation product data is given in more logical order in Table 3 below.

Table 3. Activation products

Nuclide	Half-life	Emission	Reaction	Parent %	Cross-section
Tritium	12.3 y	β	H-2(n, α)H-3	0.015	0.53 mb(T)
			Li-6(n, α)H-3	7.5	942 b(F)
			B-10(n,2 α)H-3		5.6 mb(F)
Carbon-14	5730 y	β	C-13(n, γ)C-14	1.11	0.9 mb(T)
			N-14(n,p)C-14	99.63	1.8 b(F)
			O-17(n, α)C-14	0.038	240 mb(F)
Carbon-15	2.45 s	β/γ	O-18(n, α)C-15	0.204	1.5 mb(F)
Nitrogen-13	9.97 m	$\beta+$	O-16(p, α)N-13	99.76	50 mb(P)
Nitrogen-16	7.13 s	β/γ	O-16(n,p)N-16	99.76	19 mb(F)
Oxygen-19	26.9 s	β/γ	O-18(n, γ)O-19	0.204	160 mb(T)
Fluorine-18	1.83 h	$\beta+$	O-18(p,n)F-18	0.204	300 mb(P)
Sodium-24	14.96 h	β/γ	Na-23(n, γ)Na-24	100	528 mb(T)
Phosphorus-32	14.28 d	β	P-31(n, γ)P-32	100	190 mb(T)
			S-32(n,p)P-32	95	69 mb(F)
Chlorine-38	37.2 m	β/γ	Cl-37(n, γ)Cl-38	24.2	430 mb(T)
Argon-41	1.83 h	β/γ	Ar-40(n, γ)Ar-41		
Calcium-45	162.7 d	β			
Chromium-51	27.7 d	EC/ γ	Cr-50(n, γ)Cr-51		
			Cr-52(n,2n)Cr-51		
			Fe-54(n, α)Cr-51		

Nuclide	Half-life	Emission	Reaction	Parent %	Cross-section
Manganese-54	312 d	EC/ γ	Mn-54(n,2n)Mn-54		
			Fe-54(n,p)Mn-54		
			Fe-56(n,t)Mn-54		
Iron-59	44.5 d	β/γ	Fe-58(n, γ)Fe-59		
			Co-59(n,p)Fe-59		
			Ni-62(n, α)Fe-59		
Cobalt-58	70.8 d	EC/ β/γ	Co-59(n,2n)Co-58		
			Ni-58(n,p)Co-58		
Cobalt-60	5.27 y	β/γ	Co-59(n, γ)Co-60		
			Ni-60(n,p)Co-60		
			Cu-63(n, α)Co-60		
Nickel-63	100 y	β	Ni-62(n, γ)Ni-63		
Zinc-65	244 d	β	Zn-64(n, γ)Zn-65		T
			Zn-66(n,2n)Zn-65		F
			Zn-67(n,3n)Zn-65		F
Silver-110m	250 d	β/γ			
Antimony-122	2.72 d	β/γ	Sb-121(n, γ)Sb-122		

The main radionuclides

866

Tritium. Symbol H-3, an isotope of hydrogen with one proton and two neutrons in its nucleus. Formed naturally in the upper atmosphere when neutrons arising from cosmic radiation interact with atoms of, for example, lithium. The total quantity of tritium in the biosphere that has been produced naturally is about seven kilograms or 2.5 million TBq. Tritium is also produced in nuclear reactors by fission and activation; it is present in discharges to air and water from nuclear facilities. Tritium is present in water - liquid and vapour - because it readily replaces the non-radioactive hydrogen - H-1 - atoms in a water molecule. Tritium poses a health hazard only if it is taken into the body; it decays with the emission of a very weak beta particle that cannot penetrate the skin

- 867 **Carbon-14.** Symbol C-14, an isotope of carbon with six protons and eight neutrons in its nucleus. Formed naturally in the upper atmosphere when neutrons interact with atoms of nitrogen and, to a lesser extent, carbon (-13) and oxygen. Every year about 1400 TBq of carbon-14 is formed in the atmosphere. The total quantity of carbon-14 in the biosphere that has been produced naturally is about 6000 kg or 1 million TBq, most of which is in the oceans. Carbon-14 is also produced in nuclear reactors by neutron activation of nitrogen, carbon and oxygen; it is present in discharges to air and water from nuclear facilities and in solid radioactive waste. Carbon-14 behaves in the same way as stable carbon isotopes, so it is present in all organic material in the natural carbon cycle in the biosphere. The average person contains between 3000 and 4000 becquerels of carbon-14, which will cause 250 million to 350 million beta particle missions every day. Carbon-14 decays with the emission of a weak beta particle, and its main hazard arises from taking it into the body in food, water or breathing air.
- 868 **Noble gases.** The noble gases comprise helium (He), neon (Ne), argon (Ar), krypton (Kr), xenon (Xe) and radon (Rn). Only radon has significant radioactive isotopes that occur in nature. Argon-40 makes up over 99 per cent of the stable argon present naturally in air, but if it is exposed to neutrons will form the activation product argon-41. Radioactive isotopes of krypton and xenon are formed as fission products in a nuclear reactor and their appearance outside of the reactor core indicates failure of the fuel pin containment, more commonly called the cladding. Noble gases do not become incorporated in food and the main hazard from their radioactive species is due to direct beta and gamma radiation as a plume of gas disperses.
- 869 **Iodine.** Iodine is a very volatile element in that it changes from a solid to a gas at room temperature. It is formed in a reactor as the fission products I-129, I-131, I-133 and I-135. Iodine's appearance outside of the reactor core indicates a failure in the fuel cladding. A small quantity of I-129 forms naturally in the upper atmosphere by the interaction of high energy particles from cosmic rays with xenon. Iodine can be taken into the body in food, water and by breathing.
- 870 **Particulate matter.** A number of metallic radionuclides are generated in the reactor as activation products. These are tiny quantities - in mass terms - of corrosion/erosion species that come from structural components of the reactor. These species have been exposed to neutrons and the most important radionuclides are manganese-54, cobalt-58, iron-59, cobalt-60, chromium-51, nickel-63, silver-110m, antimony-122, -124 and -125. These radionuclides can remain in the reactor coolant water in suspension or solution or become entrained in ventilation air. Both waterborne and airborne radionuclides of this type can be removed before discharge but in practice very small quantities will reach the environment. Their hazard arises from being breathed in or swallowed in food and water.

Annex 5 – Documents forming Westinghouse’s submission for GDA

Document reference	Title	Version number
UKP-GW-GL-790	UK AP1000 Environment Report	3
UKP-GW-GL-054	UK AP1000 Integrated Waste Strategy	0
UKP-GW-GL-026	AP1000 Nuclear Power Plant BAT Assessment	1
UKP-GW-GL -027	Radioactive Waste Arisings, Management and Disposal	1
UKP-GW-GL-025	Generic Site Report	1
UKP-GW-GL-028	Proposed Annual Limits for Radioactive Discharge	1
UKP-GW-GL-033	Assessment of Radioactive Discharges on Non-Human Species	1
UKP-GW-GL-034	Generic Assessment of the Impacts of Cooling Options for the Candidate Nuclear Power Plant AP1000	1
UKP-GW-GL-036	Applicability of the Environmental Permitting (England and Wales) Regulations 2007 to the AP1000	1
UKP-GW-GL-037	Applicability of COMAH Regulations	1
UKP-GW-GL-012	GDA : Summary of Disposability Assessment for Wastes and Spent Fuel arising from Operation of the Westinghouse Advanced Passive PWR (AP1000)	
REG WEC00098	GDA – Disposability Assessment for the Westinghouse Passive Pressurized Water Reactor (AP1000) – Westinghouse Electric Company Opinion	19/10/09
NXA/10897959	GDA : Disposability Assessment for Wastes and Spent Fuel arising from Operation of the Westinghouse Advanced Passive PWR (AP1000) Part 1: Main Report	
LL/10900069	GDA : Disposability Assessment for Wastes and Spent Fuel arising from Operation of the Westinghouse Advanced Passive PWR (AP1000) Part 2: Data Sheets and Inventory Tables	
UKP-GW-GL-057	UKAP1000 NDA Data Sheet Submission	0
UKP-GW-GL-737	Plant Life Cycle Safety Report	1
UKP-GW-GL-061	Acceptability of AP1000 Waste Oil for Incineration	0
APP-GW-GER-005	Safe and Simple :The Genesis and Process of the AP1000 Design	1
UKP-GW-GL-055	UK AP1000 Radioactive Waste Management Case Evidence Report for Intermediate Level Waste	0
UKP-GW-GL-056	UK AP1000 Radioactive Waste Management Case Evidence Report for High Level Waste	0

Document reference	Title	Version number
UKP-GW-GL-732	Pre-Construction Safety Report,	2
EPS-GW-GL-700	European Design Control Document	1
UKP-GW-GL-004	Process Mass Balance for AP1000 Solid Waste	0
UKP-GW-GL-058	UK AP1000 D1 Submission	0
UKP-GW-GL-023	Waste Disposability Schedule for AP1000	0
UKP-GW-GL-039	Radwaste Treatment Options Study Report	0
UKP-GW-GL-003	Solid Waste Activity Calculation from AP1000	0
APP-GW-GLN-098	Compliance with 10CFR.1406	0

Further information including submission documents can be found at:

<https://www.ukap1000application.com>

In addition to the documents above we also considered the following documents to inform our assessment

Document reference	Title	Version number
TQ-AP1000-383	Solid Radioactive Waste Data	07/01/10
SERCO/TAS/002730/003 UKP-GW-GL-029	AP1000 Generic Design Measurement and Assessment of Discharges.	27/11/08
UNREG WEC 000124N	Reference Design Point for the AP1000	23/12/09

Annex 6 – Criteria for consultation

- 871 This consultation follows the Government's Code of Practice. In particular, we aim to:
- a) formally consult at a stage where there is scope to influence the outcome;
 - b) consult for at least 12 weeks with consideration given to longer timescales where feasible and sensible;
 - c) be clear about the consultation process in the consultation documents, what is being proposed, the scope to influence and the expected costs and benefits of the proposals;
 - d) ensure the consultation exercise is designed to be accessible to, and clearly targeted at, those people it is intended to reach;
 - e) keep the burden of consultation to a minimum to ensure consultations are effective and to obtain consultees' 'buy-in' to the process;
 - f) analyse responses carefully and give clear feedback to participants following the consultation;
 - g) ensure officials running consultations are guided in how to run an effective consultation exercise and share what they learn from the experience.

Annex 7 – Places where consultation documents are advertised or can be viewed and list of consultees

Libraries

- 872 A poster advertising the consultation has been sent to 1798 local authority run libraries in England and Wales.
- 873 A poster advertising the consultation has been sent to 743 public sector management libraries in England and Wales.

Print media

- 874 An advert has been placed in one daily local newspaper in each of the areas around potential new build sites listed in DECC's draft Nuclear National Policy Statement consultation.
- 875 An advert has been placed in one weekly local newspaper in each of the areas around potential new build sites listed in DECC's draft Nuclear National Policy Statement consultation.
- 876 Where possible and when available an advert has been placed in local authority magazines which cover areas around potential new build sites listed in DECC's draft Nuclear National Policy Statement consultation.

Environment Agency Offices where the documents can be viewed

Environment Agency,
Ghyll Mount
Gillan Way
Penrith 40 Business Park
Penrith
Cumbria
CA11 9BP

Environment Agency
Coverdale House
Aviator Court
Amy Johnson Way
Clifton Moor
York
YO30 4GZ

Environment Agency
Trentside Office
Scarrington Road
West Bridgeford
Nottingham
NG2 5FA

Environment Agency,
Buckley Office
Chester Road
Buckley
CH7 3AJ

Environment Agency
Rivers House
East Quay
Bridgewater
Somerset
TA6 4YS SW

Environment Agency,
Orchard House
Endeavour Park
London Road
Addington,
West Malling
Kent
ME19 5SH

Environment Agency
Kingfisher House
Goldhay Way
Orton Goldhay
Peterborough
PE2 5ZR

List of consultees

- 877 We have written to a wide range of organisations that we believe might be interested in this consultation. A list of these is available upon request.
- 878 We have also written to MPs, MEPs and Welsh AMs and will be providing information to those who have requested it.
- 879 Our regional teams have developed local engagement plans which we've published on our joint website (www.hse.gov.uk/newreactors/publicinvolvement.htm).

Annex 8 – Response form

How to respond

Visit our website at <https://consult.environment-agency.gov.uk/portal/ho/nuclear/gda>. The online consultation has been designed to make it easy to submit responses to the questions. We would like you to register so you can respond online. This will help us to gather and summarise responses quickly and accurately. To do this you must first [log in](#) or [register](#) if you have not yet done so already.

If that is not possible, you can submit your response by email, letter or fax. Please use this form when responding. It can be downloaded at: <https://consult.environment-agency.gov.uk/portal/ho/nuclear/gda>

If you use any additional sheets, please make sure that each page is clearly labelled and numbered.

This 16 week consultation began on 28 June 2010 and will close on 18 October 2010. Please send your response to arrive by 18 October 2010.

If you have any problems with sending your response, please contact us on:

gda@environment-agency.gov.uk and phone no 08708 506 506* (Mon-Fri 8-6)*

Please read the notices below before sending your response to:

Email: gda@environment-agency.gov.uk

Post: Sue Riley
Environment Agency
Ghyll Mount
Gillan Way
Penrith 40 Business Park
Penrith
Cumbria
CA11 9BP

Fax: 01768 865606

* Approximate call costs: 8p plus 6p per minute (standard landline). Please note charges will vary across telephone providers

Data Protection Notice

How we will use your information

We will use your information to help shape our decision on the generic design assessment of the AP1000.

We may refer to any comments/issues raised by you in our Decision Document and in other Environment Agency documents related to GDA for the AP1000, unless you have specifically requested that we keep your response confidential. We may also publish all responses after the consultation has closed. We will not publish names of individuals who respond. We will publish the name of the organisation for those responses made on behalf of organisations. Please indicate on your response if you want us to treat it as confidential.

We will place your information on our databases, to be accessed by our staff or our agents, as a record of information received. We may send your information to other relevant bodies, including government departments.

We may keep your name and address on our databases so that we can advise you of any further communications relating to GDA or applications for permits for new nuclear power stations, unless you specifically ask us not to do this.

Freedom of Information Act

Confidential responses

We may publish or disclose information you provide in your response to this consultation, including personal information, in accordance with the Freedom of Information Act 2000 (FOIA). If you want us to treat the information that you provide as confidential, please be aware that, under the FOIA, there is a statutory Code of Practice with which public authorities must comply and which deals, amongst other things, with obligations of confidence.

In view of this, it would be helpful if you could explain to us why you regard the information you have provided as confidential. If we receive a request to disclose the information, we will take full account of your explanation, but we cannot give an assurance that we can maintain confidentiality in all circumstances. An automatic confidentiality disclaimer generated by your IT system will not, in itself, be regarded as binding on the Environment Agency.

About you

Name	
Organisation (if relevant)	
Job title (if relevant)	
Address (inc Postcode)	
Email	
Telephone	
Fax	

Response

Q1: Do you have any views or comments on our preliminary conclusions on management systems? If so, please use the box below to provide any details.

--

Q2: Do you have any views or comments on our preliminary conclusions on the radioactive waste and spent fuel strategy? If so, please use the box below to provide any details.

--

Q3: Do you have any views or comments on our preliminary conclusions on best available techniques to minimise the production of radioactive waste? If so, please use the box below to provide any details.

Q4: Do you have any views or comments on our preliminary conclusions on:

- a) best available techniques to minimise the gaseous discharge of radioactive waste**
- b) our proposed gaseous annual disposal limits**
- c) our proposed gaseous quarterly notification levels?**

If so, please use the box below to provide any details.

Q5: Do you have any views or comments on our preliminary conclusions on:

- a) best available techniques to minimise the aqueous discharge of radioactive waste**
- b) our proposed aqueous annual disposal limits**
- c) our proposed aqueous quarterly notification levels?**

If so, please use the box below to provide any details.

Q6: Do you have any views or comments on our preliminary conclusions on solid radioactive waste? If so, please use the box below to provide any details.

Q7: Do you have any views or comments on our preliminary conclusions on spent fuel? If so, please use the box below to provide any details.

Q8: Do you have any views or comments on our preliminary conclusions on monitoring of disposals of radioactive waste? If so, please use the box below to provide any details.

Q9: Do you have any views or comments on our preliminary conclusions on the impact of radioactive discharges? If so, please use the box below to provide any details.

Q10 Do you have any views or comments on our preliminary conclusions on the abstraction of water? If so, please use the box below to provide any details.

Q11: Do you have any views or comments on our preliminary conclusions on discharges of non-radioactive substances to water? If so, please use the box below to provide any details.

Q12: Do you have any views or comments on our preliminary conclusions on pollution prevention for non-radioactive substances? If so, please use the box below to provide any details.

Q13: Do you have any views or comments on our preliminary conclusions on EPR 10 Schedule 1 activities? If so, please use the box below to provide any details.

Q14: Do you have any views or comments on our preliminary conclusions on non-radioactive waste? If so, please use the box below to provide any details.

Q15: Do you have any views or comments on our preliminary conclusions on COMAH substances? If so, please use the box below to provide any details.

Q16: Do you have any views or comments on our overall preliminary conclusion on acceptability of the design? If so, please use the box below to provide any details.

Q17: Do you have any overall views or comments to make on our assessment, not covered by previous questions? If so, please use the box below to provide any details.

Confidentiality

Please identify any parts of your response that you consider to be confidential:

And provide your reasons:

Decision document

Would you like to receive a copy of our decision document when it is available?

Yes	<input type="checkbox"/>
No	<input type="checkbox"/>

**Would you like to find out more about us,
or about your environment?**

Then call us on

08708 506 506* (Mon-Fri 8-6)

email

enquiries@environment-agency.gov.uk

or visit our website

www.environment-agency.gov.uk

incident hotline 0800 80 70 60 (24hrs)

floodline 0845 988 1188

*** Approximate calls costs: 8p plus 6p per minute (standard landline).
Please note charges will vary across telephone providers**



Environment first: This publication is printed on paper made from 100 per cent previously used waste. By-products from making the pulp and paper are used for composting and fertiliser, for making cement and for generating energy.