

# **Impact Assessment on Wetlands: Focus on Hydrological and Hydrogeological Issues**

**R&D Technical Report W6-091/TR1**



**Centre for  
Ecology & Hydrology**

NATURAL ENVIRONMENT RESEARCH COUNCIL

**IMPACT ASSESSMENT OF WETLANDS:  
Focus on Hydrological and Hydrogeological  
Issues**

**Phase 1 Report**

R&D Technical Report W6-091/TR1

M C Acreman and F M Miller

Research Contractor  
Centre for Ecology and Hydrology, Wallingford

**Publishing Organisation**

Environment Agency, Rio House, Waterside Drive, Aztec West, Almondsbury, Bristol  
BS32 4UD Tel: 01454 624400 Fax: 01454 624409

Website: [www.environment-agency.gov.uk](http://www.environment-agency.gov.uk)

© Environment Agency 2004

ISBN 1 844 322718

All rights reserved. No part of this document may be produced, stored in a retrieval system, or transmitted, in any form or by any means, electronic, mechanical, photocopying, recording or otherwise without the prior permission of the Environment Agency and the Centre for Ecology and Hydrology.

The views expressed in this document are not necessarily those of the Environment Agency or the Centre for Ecology and Hydrology. Officers, servants or agents of either organisation, accept no liability whatsoever for any loss or damage arising from the interpretation or use of the information, or reliance on views contained therein.

**Dissemination Status**

Internal: Released to Regions

External: Publicly Available

**Statement of Use**

This report contains the results of the first phase of a two part scoping study on the impact assessment of wetlands. It highlights issues associated with wetlands impact assessment and research needs. The information in this document is for use by Agency staff and others involved in all aspects of wetlands impact assessment.

**Research Contractor**

This document was produced under R&D Project W6-091 by:

Centre for Ecology and Hydrology, Maclean Building, Crowmarsh Gifford,  
Wallingford, Oxfordshire, OX10 8BB

Tel: 01491 838800 Fax: 01491 692424

Website: [www.ceh.ac.uk](http://www.ceh.ac.uk)

**Environment Agency Project Manager**

The Environment Agency's Project Manager for R&D Project W6-091 was:

Felicity Miller, Air Land and Water, Midlands Region

Further copies of this report are available from:  
Environment Agency R&D Dissemination Centre, c/o  
WRc, Frankland Road, Swindon, Wilts SN5 8YF



tel: 01793-865000 fax: 01793-514562 e-mail: [publications@wreplc.co.uk](mailto:publications@wreplc.co.uk)

## **EXECUTIVE SUMMARY**

The Environment Agency is required under various UK and European legislation to assess the anthropogenic impacts, such as abstraction of water, operation of sluices or drainage, at individual wetland sites in England and Wales, in a consistent and defensible way. For many wetlands, there is a lack of understanding of how the water (rainfall, river flows, groundwater) interacts with the rocks, soils and organisms. In such cases, it is difficult to assess how any impacts will change the wetland's hydrology and ecology. In addition, there is no widely accepted method for carrying out an assessment. Consequently, there is a need to establish what is required to improve our conceptual understanding of these sites, as well as to provide guidelines to carry out assessments.

This report covers Phase 1 of a two part scoping study. The objectives of Phase 1 were to identify basic and applied research needs for wetlands in the UK and to identify the Agency's business needs with respect to the assessment of impacts at wetlands sites, in terms of what is required to meet the requirements of the various legislative drivers.

### **Drivers**

- International and European legislation driving impact assessment includes: Ramsar Convention; Habitats Directive (92/43/EEC); Birds Directive (79/409/EEC); Water Framework Directive (2000/60/EC)
- England and Wales legislation includes: Wildlife and Countryside Act 1981; Water Resources Act 1991; The Conservation (Natural Habitats & c.) Regulations 1994 (The 'Habitats Regulations'); Environment Act 1995; Countryside and Rights of Way Act 2000 (CROW); Water Bill
- Programmes involving impact assessment of wetlands include: Restoring Sustainable Abstraction (RSA) Programme; Catchment Abstraction Management Strategies (CAMS); Catchment Flood Management Plans; Flood Defence Catchment Strategies; Water Level Management Plans; Asset Management Programmes; Drought Plans; PSA Targets for SSSIs

### **Projects**

Agency Projects related to the current work include:

- Eco-hydrological guidelines for lowland wetlands;
- Water Resources Strategic Framework Project;
- Scoping study on guidance for the monitoring of wetlands under the requirements of the Water Framework Directive;
- Impact of Groundwater Abstractions on River Flows (IGARF);
- Model for investigation of the impacts of groundwater abstraction;
- Review of water resource assessment methods and licensing practices in fenland areas;
- Wetland Framework and Wetland Framework Extension.

### **Types of wetlands and impacts**

Types of wetland on which impact assessments have been made by the Agency include: floodplains, wet grasslands, wet woodland, wet heath, fens, reed beds, blanket bogs, mires, gravel pits, ditches, coastal grazing marshes.

Types of impact studied include: groundwater abstraction; spring abstraction; diffuse and point source pollution; construction and operation of dams and weirs; soil compaction; urbanisation; forestation/deforestation; channel deepening and widening; construction and removal (managed retreat) of embankments; construction and maintenance of drainage ditches; gravel extraction; peat extraction; vegetation cutting and removal; invasive species; setting of penning boards and sluices; and ditch clearance.

### **Project approach, issues raised and recommendations**

Questionnaires were sent to staff to obtain information on impact assessments including data collected, methods used for assessment and who was involved. Five meetings were held (Solihull, Leeds, Wallingford, Worthing, Exeter), which enabled staff to input their issues and experience and to influence Phase 2 of the project and future R&D in the area of wetlands. The issues raised fell into 8 areas. The key issues and recommendations are as follows.

#### 1. Conceptual Understanding

**Key issue:** Many impact assessments of wetlands are hampered by lack of conceptual understanding of how the wetland works hydrologically.

**Key recommendations:** Guidance and training should be produced for Agency staff on how to develop conceptual understanding of wetlands and their hydrological environment. In addition, a review of current approaches to wetland classification should be undertaken, particularly of past work by Lloyd and Tellam and current work by Wheeler and Shaw, and, if appropriate, a system that captures our conceptual understanding should be recommended. If no such classification exists, a new one should be developed.

#### 2. Objectives

**Key issue:** Within the wide range of drivers that require impact assessment of wetlands, objectives vary considerably.

**Key recommendation:** Guidance for operational staff related to setting and achieving objectives should be developed, including implications of the “do nothing” option; balancing conflicting interest (e.g. people v wildlife) and which designations take priority.

#### 3. Data and monitoring

**Key issue:** Paucity of data on wetlands and lack of guidance on what data to collect is a major limitation for impact assessment.

**Key recommendations:** A consolidated guide to designing and operating wetland monitoring should be produced for Agency staff. This should include best operational practice within the Agency. It should include a route map for planning site investigation. Consideration should be given to defining default values for wetland evaporation and hydraulic conductivity. In addition, work on water regime requirements should be extended to other vegetation types.

#### 4. Data interpretation and analysis

**Key issue:** Many tools, models and methods are available to interpret and analyse wetland data, but there is a lack of guidance on advantages and limitations of different approaches for various circumstances.

**Key recommendation:** A review should be undertaken of the methods and tools available to carry out impact assessment of wetlands, highlighting best practice in the Agency. It should include guidance on data needs of methods and the improvement in accuracy that can be obtained by collecting extra data, such as long time series and spatial heterogeneity and the costs involved.

#### 5. Assessment guidance

**Key issue:** There is currently no agreed procedure for impact assessment of wetlands and different approaches are developing in different Agency regions and areas depending on the type of wetlands, the nature of the impact and the skills and experience of the staff.

**Key recommendation:** An over-arching assessment framework is required that takes staff through the various steps involved, including conceptualisation of the hydrological systems, evaluating objectives, data collection, modelling and final assessment of impacts. The framework should be illustrated by case studies of best practice and should be a risk-based approach that allows for uncertainty and includes the likelihood of the impact.

#### 6. Wetland restoration

**Key issue:** Under the Environment Act (1995), the Agency is required to protect or enhance the environment. However, some wetland restoration or creation projects represent an additional consumptive use of water in an already over-abstracted catchment or may increase flood risk.

**Key recommendation:** Guidance should be developed to determine under what circumstances wetland restoration is appropriate, with particular reference to conflicting priorities between enhancing and protecting the environment and safe-guarding the water needs of abstractors and flood protection.

#### 7. Partnerships, project management and funding

**Key issue:** wetland projects are multi-disciplinary and require collaboration from a range of organisations including water companies, English Nature, NGOs and local authorities.

**Key recommendation:** Guidance on project planning and management specific to wetlands should be developed.

#### 8. Knowledge management

**Key issue:** It is often difficult for staff working on impact assessments of wetlands to find relevant information and best practice from other parts of the Agency.

**Key recommendation:** The potential for establishing wetland groups on a local level should be considered for sharing experience and best practice. A national point of contact for wetland issues and information should be established. The feasibility of a national database to hold information on wetlands should be examined.

### **Database**

Part of the project was concerned with developing a database of reports and published scientific papers related to UK wetlands. These included internal Agency and Centre for Ecology and Hydrology (CEH) reports. The database is in Microsoft Access format and can be found on a CD ROM in the back of this document. Copies of papers and reports should be requested in the first instance through normal inter-library loan facilities; if this proves impossible CEH library should be approached.

## **Research needs**

A workshop was held on 2-3 February 2002 for CEH staff to identify basic and applied research needs. This was part an exercise to develop the Wetlands Research Coordination Group, a multi-disciplinary pool of experts within CEH laboratories across the UK. The scope of the workshop was not exhaustive, but focused principally on the areas of scientific expertise and experience of CEH staff.

Key recommended areas for basic research included:

- Relationships between plant communities, soil moisture and micro-topography.
- Evaporation processes in grasses, reeds and wetland trees.
- Hydraulic connectivity between aquifers and wetlands

Recommended areas for applied research included:

- Methods and tools for restoring wetlands
- Conceptualising and modelling connectivity between aquifers and wetlands
- The role of wetland functions in achieving ‘good ecological status’ of the Water Framework Directive

## **Phase 2**

The second phase of the project will develop four themes:

- Identify or develop a suitable conceptual classification of wetlands for water resources. This will be based on the relationship of the wetland to catchment hydrology and hydrogeology of aquifer units. The end result will be a classification of different conceptual wetland settings to cover the main settings in England and Wales.
- Write guidance on how to undertake a quantitative water balance of a particular wetland site. The need for guidance on how to develop conceptual understanding of wetlands has been highlighted; a quantitative water balance can be used to test understanding and is an essential pre-requisite to any impact assessment.
- Review current knowledge of evaporation rates from different wetland vegetation communities. If possible, look-up tables of default values should be produced, together with guidance on how to estimate evaporation from different methods.
- Review the methods and tools available to undertake assessment of the anthropogenic impacts on wetlands, highlighting best practice in the Agency as a basis for a consistent approach to assessment. The tools reviewed should be incorporated into a hierarchy for assessment, starting with simple analytical methods and ranging up to complex numerical models.

# CONTENTS

<b>EXECUTIVE SUMMARY</b>	<b>i</b>
<b>ACKNOWLEDGEMENTS</b>	<b>vi</b>
<b>1. INTRODUCTION</b>	<b>1</b>
1.1 Background	1
1.2 Objectives	1
1.3 Programme of work	2
<b>2. AGENCY DUTIES</b>	<b>3</b>
2.1 International and European legislation	3
2.2 England and Wales legislation	5
2.3 Programmes	7
<b>3. RELATIONSHIP WITH OTHER PROJECTS</b>	<b>10</b>
3.1 Eco-hydrological guidelines for lowland wetlands	10
3.2 Water Resources Strategic Framework Project	10
3.3 Scoping study on guidance for the monitoring of wetlands under the requirements of the Water Framework Directive (Gavin, 2003)	12
3.4 Impact of Groundwater Abstractions on River Flows (IGARF)	12
3.5 Model for investigation of the impacts of groundwater abstraction	12
3.6 A review of water resource assessment methods and licensing practices in fenland areas (Simons and Clarke, 2002)	13
3.7 Wetland Framework (Wheeler and Shaw, 2000) & Wetland Framework Extension (2002/3)	13
<b>4. TYPES OF IMPACT ASSESSMENT</b>	<b>14</b>
4.1 Types of wetland	14
4.2 Types of impact	14
<b>5. UNDERSTANDING WETLANDS</b>	<b>16</b>
5.1 Conceptual understanding	16
5.2 Why conceptual understanding is important	16
5.3 Conceptual understanding and impact assessment	19
5.4 Hydrological elements	20
5.5 Developing conceptual understanding	24
<b>6. ISSUES IDENTIFIED</b>	<b>26</b>
6.1 Conceptual understanding	27
6.2 Objectives of impact assessment	28
6.3 Data and monitoring	31
6.4 Assessment tools	35
6.5 Assessment guidance and procedures	38
6.6 Restoration and mitigation	39
6.7 Partnerships, project management and funding	41
6.8 Knowledge management	42



<b>7. DATABASE</b>	<b>44</b>
<b>8. RESEARCH NEEDS</b>	<b>45</b>
<b>9. RECOMMENDATIONS</b>	<b>48</b>
9.1 Implementation Class 1 (for Phase 2 of this project)	48
9.2 Implementation Class 2 (for consideration for future work)	48
9.3 Implementation Class 3 (for other functions of the Agency to consider)	49
<b>10. SCOPE OF WORK FOR PHASE 2</b>	<b>51</b>
Objectives	51
Programme of work	51
<b>REFERENCES</b>	<b>52</b>

<b>Annex 1 ABBREVIATIONS</b>	<b>55</b>
------------------------------	-----------

<b>Annex 2 RETURNED QUESTIONNAIRES</b>	<b>56</b>
--	-----------

Alverston	Lower Eastern Rother
Ant Broad and Marshes	Marazion Marsh
Arun Valley	Newbald Becksies
Brading Marshes – Isle of Wight	North Meadow and Clattinger Farm
Cridmore Bog	Oakmere
Crymlyn Bog	Pevensey Levels
Dartmoor	Pulfin Bog
Derwent Valley	Shirley Pool
Dorset Heaths	South Pennine Moors
East Devon Pebble Bed Heaths	Stour Marshes
Emer Bog	Swale Marshes – Low Halstow to Whitstable
Exmoor	Swale Marshes – Sheppey & Iwade
Fenns, Whixall, Wem Cadne & Bettisfield Moss	The Moors
Great Cressingham Fen	Upper Severn
Isle of Wight Chines	Weston Fen
Kennet and Lambourn Floodplain	Witherslack mosses – (Meathop, Nicholls and Foulshaw)

## **CD-ROM**

Database of reports and published scientific papers related to UK wetlands.

## ACKNOWLEDGEMENTS

In addition to the board members, the following Agency staff contributed to the project through attendance at meetings, completing questionnaires and providing supplementary information. The project team would like to thank to all those who provided help and information.

Will Spendlove (Hydrologist, Midlands Region), Gideon Carpenter (Hydrologist, Environment Agency Wales), Monica Garcia (Hydrologist, Midlands Region), Mark Reid (Regulatory Officer, Anglian Region), Paul José (FRB, Anglian Region), Louise Evans (Licensing, Anglian Region), Keith Seymour (Hydrogeology, North West Region), John Ingram (Hydrogeology, North West Region), Iwan Lawton (Hydrogeology, North West Region), Rolf Farrell (Hydrogeology, North East Region), Ineke Jackson (Water Resources, North East Region), David Lindsay (Technical Specialist, North East Region), Liz Chalk (Biodiversity, North East Region), Kath Charles (Policy Advisor Water Resources Habitats Directive, Head Office), Graham Scholey (Conservation Technical Specialist, Thames Region), Rory Callan (Groundwater, Thames Region), Chris Catling (Biodiversity, Thames Region), Mike O'Shea (Water Resources, Southern Region), Rupert Clubb (Flood Defence, Southern Region), Jo Simmons (Water Quality, Southern Region), Ann Skinner (Policy and Process, Head Office), Phil Griffiths (Water Resources, Southern Region), Cathy Howard (Water Resources, Southern Region), Sarah Norton (CAMS Officer, Southern Region), Karen McHugh (Water Resources, Southern Region), Tony Burch (Flood Defence, Southern Region), Alison Rennie (Water Resources, Southern Region), Rod Murchie (Habitats Directive, Southern Region), Tim Holzer (Habitats Directive, Southern Region), Tim Sykes (Biodiversity Technical Specialist, Southern Region), Sean Furey (Water Resources, Southern Region), Bridget Thorn (Water Resources, Southern Region), Ben Bunting (Habitats Directive, South West Region), Margaret Thornley (Groundwater, South West Region), Jim Grundy (Groundwater, South West Region), Cliff Tubb (WR Policy Advisor, Head Office) Anne Kemlo (Hydrology, South West Region), Pauline Johnston (Groundwater, South West Region).

# 1. INTRODUCTION

## 1.1 Background

Wetlands are a fundamental part of the UK landscape, embracing a diverse range of habitats including marshes, fens, bogs, wet grasslands, wet woodland (carrs), floodplains, mudflats, estuaries and ponds. Wetlands are important regulators of the hydrological cycle and provide vital habitat for rare and endangered species. However, wetlands are vulnerable to many influences, which include changes in water availability caused by abstraction of near-by surface or groundwater, flood management (such as operation of weirs and dams) and internal management of ditch water levels and vegetation. The Environment Agency is required under various UK and European legislation to assess the anthropogenic impacts at individual wetland sites in England and Wales, in a consistent and defensible way. For many wetlands, there is a lack of understanding of how the water (rainfall, river flows, groundwater) interacts with the rocks, soils and organisms. In such cases, it is difficult to assess how any impacts will change the wetland's hydrology and ecology. In addition, there is no widely accepted method for carrying out an assessment. Consequently, there is a need to establish what is required to improve our conceptual understanding of these sites, as well as to provide guidelines to carry out assessments. This could take the form of, for example, technical guidance on monitoring or new assessment tools.

This project was established to review the impact assessment of wetlands in two phases. The first phase was aimed at defining the Agency's specific business needs for impact assessment and to identify basic and applied research requirements. It was expected that this would highlight issues related to many different parts of the Agency's business including water resources, water quality, biology and ecology. A second phase of the project was intended to focus on the Agency's business needs related to water resources. Issues outside this area would be passed to other functions to take forward as appropriate.

The project was jointly funded by the former National Groundwater and Contaminated Land Centre (NGCLC) – now part of the Agency's 'Science Group' - and the Centre for Ecology and Hydrology (CEH), under the Memorandum of Understanding between CEH and the Agency. The study was carried out by CEH.

## 1.2 Objectives

The objectives for Phase 1 were:

- To identify basic and applied research needs for wetlands in the UK;
- To identify the Agency's business needs with respect to the assessment of impacts at wetlands sites, in terms of what is required to meet the requirements of the various legislative drivers.

The provisional objectives for Phase 2 at the outset of the project were:

- To improve our conceptual understanding of wetland systems and how they interact with surrounding surface and groundwater systems, highlighting specific water resource issues.
- To review the methods and tools available to carry out assessment of the anthropogenic impacts on wetlands.

### **1.3 Programme of Work**

The programme of work for carrying out Phase 1 of the project was as follows:

- a. Run a workshop to identify basic and applied research needs in general terms.
- b. Write a short review of the Agency's duties with respect to wetland protection under the relevant legislation.
- c. In consultation with key operational Agency staff, assess the Agency's business needs in order to carry out the duties identified in b. above and assess where there are gaps in the Agency's current knowledge or capability in meeting these business needs and how these can be filled e.g. by technical guidance, new procedures/methodologies, new research, technical tools.
- d. Summarise how this project relates to other ongoing work within the Agency.
- e. Recommend future work and define outline proposals for priority projects. (It was anticipated that this could identify some projects that are beyond the scope of Phase 2 of this project and/or are more appropriate to be carried out elsewhere, either within the Agency or externally).
- f. In consultation with the Project Board, define the objectives for Phase 2 of this project.
- g. Compile a database containing the key literature used in the project. This should include a keyword search facility and will include internal Agency reports as well as external work.

## 2. AGENCY DUTIES

There are several different legislative drivers and associated programmes of work that require the Agency to carry out technically defensible impact assessments at wetlands. These are discussed in three sections: International and European legislation; England and Wales legislation; and Programmes.

**Table 2.1: Drivers for assessment of wetlands**

<b>International and European legislation</b>	<b>Programmes</b>
<p>Ramsar Convention  Habitats Directive (92/43/EEC)  Birds Directive (79/409/EEC)  Water Framework Directive (2000/60/EC)</p> <p><b>England and Wales legislation</b>  Wildlife and Countryside Act 1981  Water Resources Act 1991  The Conservation (Natural Habitats &amp; c.) Regulations 1994 (The ‘Habitats Regulations’)  Environment Act 1995  Countryside and Rights of Way Act 2000 (CROW)  Water Bill</p>	<p>Restoring Sustainable Abstraction (RSA) Programme  Catchment Abstraction Management Strategies (CAMS)  Catchment Flood Management Plans  Flood Defence Catchment Strategies  Water Level Management Plans  Asset Management Programmes  Drought Plans  PSA Targets for SSSIs</p>

### 2.1 International and European Legislation

#### 2.1.1 Ramsar Convention

The Convention on Wetlands is an intergovernmental treaty that was adopted on 2 February 1971 in the Iranian city of Ramsar and has come to be known popularly as the "Ramsar Convention". The Convention covers all aspects of wetland conservation and wise use, recognizing wetlands as ecosystems that are extremely important for biodiversity conservation in general, and for the well-being of human communities. As a signatory to the Convention, the UK is required to:

- designate sites to the Ramsar list;
- formulate and implement national land-use planning so as to promote, as far as possible, the wise use of wetlands in their territory;
- establish nature reserves in wetlands, whether or not they are included in the Ramsar List, and they are also expected to promote training in the fields of wetland research, management and wardening.

### **2.1.2 The Habitats Directive**

The Habitats Directive (92/43/EEC) aims to contribute to ensuring biodiversity through the conservation of natural habitats and of wild fauna and flora. The Directive lists habitats and species of European importance and makes provision for designating Special Areas of Conservation (SACs) within which they are represented. The measures set out in the Directive are designed to maintain at, or restore to, a 'favourable conservation status' the listed species and habitats. It also states that land-use planning and development policies should encourage the development of features of the landscape which are of major importance for wild fauna and flora, such as rivers and ponds. The Habitats Directive is implemented in the UK with the Birds Directive under the provisions of The Conservation (natural Habitats & c.) Regulations 1994 (the 'Habitats Regulations').

### **2.1.3 The Birds Directive**

The Birds Directive (79/409/EEC) requires that special measures be taken to conserve the habitats of listed species in order to ensure their survival and reproduction in their area of distribution. The most suitable areas for these species are classified as Special Protection Areas (SPAs). Similar measures are to be taken in respect of regularly occurring migratory species not listed in the Directive. Details of designated sites are available from EN/CCW. A number of important wetlands are designated under the Birds Directive, for example the Somerset Levels and Moors SPA. The Birds Directive is implemented in the UK, along with the Habitats Directive under the provisions of The Conservation (Natural Habitats & c.) Regulations 1994 (the 'Habitats Regulations').

### **2.1.4 Water Framework Directive**

The fundamental objective of the Water Framework Directive (2000/60/EC) is the achievement of 'good status' in all water bodies. Groundwaters, rivers, lakes, transitional waters, coastal waters, and artificial or heavily modified systems can all be defined as water bodies. The achievement of good status in water bodies is aimed at, amongst other things, conservation of associated ecosystems such as wetlands. Article 1 (a) states that the Directive will '*establish a framework for the protection of inland surface waters, transitional waters, coastal waters and groundwaters, which: 'prevents further deterioration and protects and enhances the status of aquatic ecosystems and, with regard to their water needs, terrestrial ecosystems and wetlands directly depending on the aquatic ecosystems.'*' This purpose will be made operational through the application of the Directive's environmental objectives as far as they relate to wetlands, and through the use of wetland protection, creation and restoration to help to fulfil these objectives in a cost effective and sustainable manner. (For further details see Davis *et al*, 2003 and Gavin, 2003)

The Directive will be addressed via River Basin Management Plans, which give particular emphasis to the integrated management of groundwater and surface water. Two of the main aims within this are to prevent further deterioration, protect the status of aquatic ecosystems and associated wetlands, and to promote sustainable water abstraction by developing an appropriate programme of measures.

## **2.2 England and Wales Legislation**

### **2.2.1 The Wildlife and Countryside Act**

The Wildlife and Countryside Act 1981 is one of the major legal instruments for wildlife protection in the UK. This legislation is the means by which the Convention on the Conservation of European Wildlife and Natural Habitats (the 'Bern Convention') is implemented in Great Britain. The Act also prohibits the release of non-native species into the wild (Section 14). This is to prevent the expansion of exotic species that could threaten our native wildlife. The CRoW Act (2000) has amended and updated many of the provisions within the Wildlife & Countryside Act.

### **2.2.2 Water Resources Act**

The Water Resources Act 1991 consolidated enactments relating to the National Rivers Authority (NRA) functions of water resources, water pollution, flood defence and land drainage, fisheries and navigation. The NRA was given the duty to promote the conservation and enhancement of the natural beauty and amenity of inland and coastal waters (and associated land); the conservation of flora and fauna, which are dependent on an aquatic environment; and the use of waters and land for recreational purposes. The NRA also had a duty to conserve, redistribute or otherwise augment water resources in England and Wales, and had to ensure that water companies had sufficient resources to meet their reasonable needs. Taking these duties together, the NRA was not simply an environment protection agency, but had to balance the needs of the abstractor and the environment.

### **2.2.3 The Conservation (Natural Habitats &c.) Regulations 1994 (the 'Habitats Regulations')**

The Conservation (Natural Habitats & c.) regulations 1994, known commonly as the 'Habitats Regulations', implement in Great Britain the requirements of the EU Habitats Directive and also secure the protection of areas classified under the Birds Directive (Council Directives 92/43/EEC and 79/409/EEC respectively).

As a 'Competent Authority' under the Habitats regulations, the Agency has a legal duty to ensure that no Agency activity or permission results in an adverse effect, whether directly or indirectly, on the integrity of a classified Special Protection Area (SPA) or a candidate or designated Special Area of Conservation (SAC).

This has been implemented via a staged risk assessment, and is applicable to all new permissions (under Regulation 48) as well as existing permissions (under Regulation 50 or Regulation 3(4) of the Habitats Regulations).

The 4 stage process is:

Stage 1: Identifying relevant applications or existing abstraction licences;

Stage 2: Assessing likely significant effect (desk study assessment);

Stage 3: Appropriate assessment (numerical impact assessment in proportion to the nature, scale and duration of the activity and sensitivity of the site);

Stage 4: Determination of the application/or existing consent.

For the review of consents, designated sites have been assigned a priority based on known risk to the site from Agency permissions, and the extent to which ‘favourable condition’ of the site can be realised through changes to those permissions. Stage 3 – the ‘appropriate assessment’ must be completed by 31<sup>st</sup> March 2004, 2006 or 2008 for High, Medium and Low priority sites, respectively, and Stage 4 must be completed 2 years after the Stage 3 deadline, ie. by 31<sup>st</sup> March 2006, 2008 and 2010 for High, Medium and Low priority sites respectively.

Specific wetland habitats under the Directive include: fens, bogs and wet habitats (including wet grasslands); riverine habitats and running waters; standing waters; coastal habitats; estuarine and intertidal habitats.

#### **2.2.4 Environment Act**

Under the Environment Act (1995), the duties of the NRA to protect or enhance the environment and meet the reasonable needs of abstractors, were transferred to the Environment Agency. In addition, the Agency acquired the functions of waste regulation authorities (under the Control of Pollution Act 1989 and Environmental Protection Act 1990). The Agency also has a duty to promote the conservation of flora and fauna which are dependent on the aquatic environment by working with and providing advice to:

- Statutory Agencies, Local Authorities and Highways engineers
- DEFRA, agricultural advisors, farmers and landowners
- Environmental organisations, educational and research institutes
- Water companies and the private sector
- The general public and local communities

#### **2.2.5 Countryside and Rights of Way Act (CRoW)**

The CRoW Act 2000 is focused primarily on new provisions for public access to the countryside, to amend the law relating to public rights of way and to enable traffic regulation orders to be made for the purpose of conserving an area's natural beauty. However, it also amends the law relating to nature conservation and the protection of wildlife and areas of outstanding natural beauty.

Any Government departments, in carrying out their functions, should have regard, so far as is consistent with the proper exercise of those functions, to conserve biological diversity in accordance with the Convention on Biological Diversity. A list must be published of the living organisms and types of habitat which are of principal importance for biological diversity. They must also take, or promote the taking by others of, such steps as appear to be reasonably practicable to further the conservation of the living organisms and types of habitat included in any list published by the authority under this section. Under the CRoW Act it will be necessary to undertake assessments of SSSIs.

#### **2.2.6 Water Bill**

The Government, the Agency and others consider that significant changes to the water abstraction licensing system are needed to help ensure water resources are used sustainably. During the last few years, Government proposals and decisions have been set out in a series of consultation and decision papers, resulting in the publication of the



draft Water Bill in November 2000. The proposed Water Bill will complement existing Agency initiatives, such as the review and curtailment of damaging abstractions, the development of a framework for trading in water rights and implementation of the Agency's policy on time limited licences. It may include the requirement to issue licences for previously exempt activities such as canal abstractions and dewatering. The Bill is likely to be introduced during the current Parliamentary Session.

## **2.3 Programmes**

### **2.3.1 Agency's Restoring Sustainable Abstraction Programme**

The overall aim of the Restoring Sustainable Abstraction (RSA) Programme, set up in 1999, is to identify rivers or wetlands that may have been affected by abstraction. This work is the successor to the Alleviation of Low Flows (ALF) Programme and covers both designated (SSSIs, SPAs and SACs) and non-designated sites. The RSA Programme includes the Restoring Sustainable Abstraction Catalogue, a prioritised database of sites suspected of being detrimentally affected by abstraction. Although the database is currently not available, it is being redeveloped, after which it will provide a useful source of information. The remediation strategy for England and Wales will address concerns highlighted by the Environment Agency (the Agency) and Conservation groups, and voiced by Environmental groups about un-sustainable abstraction and aims to put this right. Where possible the RSA Programme provides remedial strategies to restore an ecologically acceptable flow/level regime and/or aesthetic and amenity value. This programme is clearly relevant to wetlands that are impacted by abstraction.

### **2.3.2 Catchment Abstraction Management Strategies**

In March 1999, the Government reviewed the system of issuing licences for abstracting water and made a number of changes. Foremost amongst these was the development of Catchment Abstraction Management Strategies (CAMS). The main aims of CAMS are:

- to make information on water resources and licensing practice available to the public;
- to provide a consistent approach to local water resources management, recognising the reasonable needs of water users and the environment;
- to provide the opportunity for greater public involvement in managing the water resources of a catchment.

In order to try and achieve these aims each CAMS is being developed through a process of consultation with local stakeholders. The CAMS process was launched in April 2001 and involves development of a CAMS for every catchment in England and Wales. These will be reviewed every 6 years on a rolling programme. The Resource Assessment and Management (RAM) Framework provides a consistent technical approach to water resource assessment and management within the CAMS process. However, wetlands are not explicitly included within the RAM Framework. Consequently, an alternative approach has had to be developed for catchments such as the Stour, in Kent, which includes sub-catchments, e.g. the Stour Marshes, which are dominated by wetlands and managed by control of levels rather than flow.

### **2.3.3 Catchment Flood Management Plans and Flood Defence Catchment Strategies**

The aim of Catchment Flood Management Plans (CFMP) is to adopt a whole system approach to the management of flood risk to achieve a flood management strategy that is capable of responding to climate change. CFMPs will have a sound understanding of the hydrological and hydraulic processes at work in the catchment that influence the generation and dissipation of all types and frequencies of river flooding. This offers opportunities to restore wetlands and natural floodplain functioning as a contribution to reducing flood risk and will require appropriate economic incentives to assist landowners to change land management practices where these increase run-off. Within the CFMPs are Flood Defence Catchment Strategies that provide details of economic value and environmental value in terms of the flood defence strategy. These plans and strategies need to consider both impacts on wetlands and the potential to utilise wetlands as agents for flood management.

### **2.3.4 Water Level Management Plans**

Water Level Management Plans were initiated by MAFF (now within DEFRA) to provide a means by which water level requirements for a range of activities in a particular wetland area, including agriculture, flood defence and conservation, can be balanced and integrated. The Agency, where it is the operating authority liaises with English Nature, Internal Drainage Boards, conservation groups and others to prepare plans to ensure key water levels are safeguarded. The initial programme concentrated on SSSIs. Implementation relies largely on the existence of other incentive schemes such as the Wildlife Enhancement Scheme and Countryside Stewardship.

### **2.3.5 Asset Management Programmes**

The economic regulator for the water and sewerage industry in England and Wales (Ofwat) has a primary duty of ensuring that the water companies are able to carry out and finance their functions under the Water Industry Act 1991 (WIA91). Ofwat sets price limits that allow each company to do this while protecting the interests of customers. Price limits are reviewed every five years. As part of the review, water companies put forward asset management plans that detail proposed investments, which can include schemes to mitigate negative environmental impacts of abstraction. Such schemes can include funds for environmental improvements to wetlands.

### **2.3.6 Drought Plans**

Water companies all have arrangements in place to collect, store and transfer water to cope with normal fluctuations in rainfall. In a drought these established arrangements may not be enough to ensure full supplies for an indefinite period ahead. There is a range of actions that may be taken by a water company to manage this situation and ensure security of public water supply. Water companies are required to agree a detailed, publicly available drought plan with the Environment Agency. A drought plan sets out the range of drought situations that may occur, and indicates the range and sequence of actions a company would expect to take at different stages in a drought. When a drought occurs water companies may apply for a drought order or a drought act that relaxes normal restrictions on abstraction to meet their customers' demand for

water. Relaxing the restrictions may lead to degradation of wetlands at a critical time of water stress, although identification of potential environmental impacts together with monitoring and assessment procedures to minimise impacts will have been included in the Drought Plan.

### **2.3.7 Public Service Agreement (PSA) targets for SSSIs**

English Nature aims to maintain a series of Sites of Special Scientific Interest (SSSIs) that are well managed and in favourable condition. The condition is assessed using standards across the UK. A feature on a site (such as a particular plant species) will be recorded as favourable or recovering when the set criteria are met that ensure the feature will be sustained in the long term. The government has set a Public Service Agreement (PSA) target of 95% of SSSIs to be in good condition (or unfavourable recovering) by 2010. Impact assessments will need to be undertaken on wetland SSSIs that are not in good condition and where no previous assessment work has been done.

### **3. RELATIONSHIP WITH OTHER PROJECTS**

The Agency is undertaking a range of projects related to wetlands and impact assessment. It is important to ensure synergy between them and avoid major gaps and overlaps. Each of the projects that relates to the current work is described briefly.

Figure 3.1 shows the major Environment Agency projects on wetlands and how these relate to the various stages involved in an impact assessment from the legislative driver and business need to the ecological response and assessment of impact. Clearly many projects are providing guidance on more than one stage (see numbers against each project that refer to different stages).

Agency staff can also access information about these projects on the Easinet.

#### **3.1 Eco-Hydrological Guidelines for Lowland Wetlands**

The main objective of the project is the production of a user-friendly guide of generic eco-hydrological prescriptions for the requirements of EU-designated freshwater wetland features in the Anglian Region of the Environment Agency. As a result of the generic nature of the guidelines they will have wider applicability to other areas in the lowlands of England and Wales where the same interest features exist. The guidelines contain in a user-friendly format the hydrological, hydro-chemical and site management conditions required by each of 16 wetland plant communities within the National Vegetation Classification (NVC). For some communities, such as wetland grasslands and reed swamps, hydrological requirements are well defined as a result of detailed studies over many years. In contrast, the hydrological requirements of other communities, such as fens, are less accurately defined.

#### **3.2 Water Resources Strategic Framework Project**

This project aims to bring together existing habitat and species literature into one overview document. The work is divided into two main sections.

##### **I. Water Resource Requirements of Particular Habitats and Species (Atkins, 2003)**

Atkins was commissioned by the Agency to produce summaries on the likely water resource requirements for 30 habitats and 26 species listed in Annex I and II of the Habitats Directive. Habitats include mires, bogs, fens and wet heaths. These habitats and species do not represent the full list of habitats and species designated but represent those which were identified as most likely to be impacted from changes to the freshwater regime (depth, flow etc). The guidance notes produced are intended to provide a basic ecological description of each habitat and species identified which will be of use as a starting point but do not represent a comprehensive review of all available material.

## Steps in Assessment

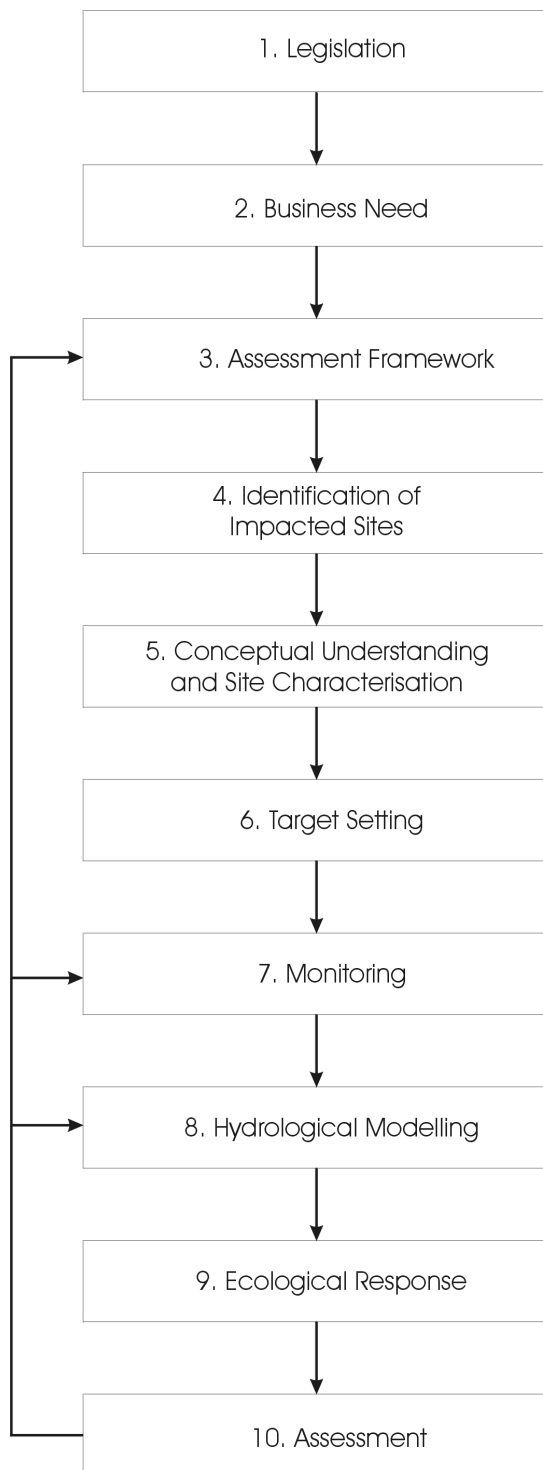

## R+D Projects

Impact Assessment of Wetlands  
(1, 2, 5, 7, 8 & 10)

Agency's Vision and  
Area Business Plans (2)

Water Resources Strategic  
Framework (Entec & Atkins)  
(3, 5, 7, 8 & 9))

Wetland Framework and  
Wetland Framework  
Extension - 'Wetmechs' -  
(Sheffield University) (5 & 9)

WFD Monitoring - (Atkins)  
Monitoring Guidelines (NGWCLC)  
Anglian Monitoring Project (7)

IGARF (NGWCLC)  
Impact Assessment  
of Wetlands - (CEH) (8)

Eco-Hydrological  
Guidelines - (Various/Entec) (5 & 9)

Site assessments - (Entec) (10)

**Figure 3.1: Contribution to impact assessment of key Agency wetland-related projects**

II. Water Resources & Conservation: A framework for the assessment of the hydrological requirements of Habitats and Species. (Betts and Papaioannou, 2003)

This study collated tools and methods that can be used for impact assessment/monitoring to be used when carrying out appropriate assessment both for the review of existing consents and in the determination of new or varied licences. It includes a decision tree that indicates resource requirements/applicability.

### **3.3 Scoping Study on Guidance for the Monitoring of Wetlands under the Requirements of the Water Framework Directive (Gavin, 2003)**

This project included: identification of the types of wetlands that fall under the Directive; the water related factors underpinning these wetlands; guidance on how these factors should be monitored and details of current monitoring activities in wetlands within the Agency and other organisations. Questionnaires were sent to a range of organisations including DEFRA, CCW, Environment Agency, Wildfowl and Wetland Trust, WWF, Wildlife Trusts and RSPB. The key conclusions of the report are that:

- wetland monitoring is conducted in response to specific projects and Agency obligations
- the type and intensity of monitoring depends on the designation of the site
- monitoring was primarily related to groundwater levels with additional monitoring of surface water (flow and level) and ecological features;
- problems encountered are commonly caused by a lack of resources and funding

Key recommendations made by the report are:

- development of monitoring guidance to assess different facets of wetland hydrology/ ecology
- development of user/practical tools for the rapid assessment of wetland water balances (particularly evaporation)
- creation of case studies as guides to further the hydrological understanding for particular wetland types
- development of a UK database of wetland habitat and summary information
- assessment of costs involved in monitoring

### **3.4 Impact of Groundwater Abstractions on River Flows (IGARF)**

The IGARF programme of work consists of guidance and tools, primarily to assist with abstraction licence determinations, to estimate the 'Impact of Groundwater Abstractions on River Flows'. Previous work produced guidance and software tools, some of which are in widespread use across the Agency. These are recognised as valuable tools for Water Resource Management. A project is currently underway to further enhance the functionality and ease of use of IGARF1, and to expand the guidance to bring it in line with the latest best practice as advocated by the National Groundwater and Contaminated Land Centre (now part of the Science Group). The updated version of IGARF1 and associated user manual will be released in 2004.

### **3.5 Model for Investigation of the Impacts of Groundwater Abstraction**

This project, which has recently started, aims to test the capability of the existing pilot object-oriented model (ZOOMQ3D) as a means of estimating the impacts of

groundwater abstraction on river flows. The study will consider whether models can be developed with ZOOMQ3D that produce more accurate estimates than the existing analytical tools IGARF 1 & SPIGARF, but which can be set up in days rather than the years it takes to develop a full regional model. The model will be tested on a series of hydrogeological settings. Although wetlands are not explicitly included in this phase of the work, they will be considered if the first phase is successful.

### **3.6 A Review of Water Resource Assessment Methods and Licensing Practices in Fenland Areas (Simons and Clarke, 2002)**

This work has reviewed the methods that have been used to assess water resources availability in fenland areas and how these translate into abstraction licensing policy and practice. The proposed approach parallels that adopted in the RAM framework by focusing on modelling fenland water levels against levels proposed for ecological protection. However, further work is needed to trial the proposed methodology in practice, and to revise the ecological weighting aspects for level controlled systems before it can be adopted.

### **3.7 Wetland Framework (Wheeler and Shaw, 2000) & Wetland Framework Extension (2002/3)**

The original project used data from over 80 wetlands (fens and bogs only) in Eastern England to develop a classification system of WETland water supply MECHANISM types (WETMECS) that combines landscape situation, water supply mechanism, hydrotopographical elements, acidity (base-richness) and fertility. A key aim was to identify homogeneous wetland types that are supported by the same hydrological processes and thus broad classes of wetlands that would respond in a similar way to external or internal impacts. However, it was clear from the study that there are several different hydrological mechanisms which can deliver the same National Vegetation Classification (NVC) wetland vegetation community when combined with other variables, such as water quality and soil/geology type.

The work has identified 9 main WETMECS for Eastern England, based primarily on water supply mechanism. For each type, the wetlands are further classified into sub-types according to such characteristics as the strength of spring discharges. Within each sub-type, there are two further categories, which define 'ecological types': base-status (base-rich, sub-neutral and base poor) and fertility (oligotrophic, mesotrophic and eutrophic). Base status category can be determined on site by pH measurements. The fertility category requires phytometric analyses of soil samples. For both these categories, the plant communities present may be used as a surrogate indicator. NVC community types are then related to ecological types.

Work carried out under the Wetland Framework Extension project will expand the range of wetland types covered to make it applicable throughout England and Wales. The current phase also includes a training and awareness element. The outputs from this phase of the project include a new suite of 'Wetland guidelines' to supplement the ones outlined in section 2.1.

## **4. TYPES OF IMPACT ASSESSMENT**

### **4.1 Types of Wetland**

The Agency is involved with impact assessments at many types of wetland, including (though not restricted to) the following:

- Floodplains
- Wet grasslands
- Wet woodland
- Wet heath
- Fens
- Reed beds
- Blanket bogs
- Mires
- Gravel pits
- Ditches
- Coastal grazing marshes

### **4.2 Types of Impact**

Many types of impact were identified during meetings held with operational Agency staff. These are listed below. Note that this is not necessarily an exhaustive list of all potential impacts.

Catchment water management

- Groundwater abstraction
- Spring abstraction
- Surface water abstraction and diversion

Catchment land management

- Soil compaction
- Urbanisation
- Forestation/deforestation
- Land tillage
- Diffuse and point source pollution

River engineering

- Channel deepening and widening
- Construction and removal (managed retreat) of embankments
- Construction and maintenance of drainage ditches
- Construction and operation of dams and weirs

Mineral extraction

- Gravel extraction
- Peat extraction
- Mining subsidence



#### Site management

- Vegetation cutting and removal
- Grazing
- Invasive species
- Setting of penning boards and sluices
- Ditch clearance
- Back filling of trenches with materials of different permeability or mineral content

In addition to the above anthropogenic impacts, wetlands are also impacted by natural processes that may alter wetlands from their target ecological state. These include:

- Climatic variation, such as drought
- Extreme flooding
- Saline incursion or intrusion
- Vegetation succession

## **5. UNDERSTANDING WETLANDS**

### **5.1 Conceptual Understanding**

Wetlands are complex systems resulting from the interaction of water, soils, air, energy, rocks, plants and animals. Knowledge of how these components interact with each other and the wider catchment is essential to understand how external and internal changes may impact on a wetland. This knowledge is termed conceptual understanding. This may initially be at a qualitative level, for example whether the major source of water for a wetland is rainfall, surface flow or groundwater. Clearly if the wetland is supported primarily by groundwater then abstraction from the underlying aquifer could have an impact on the wetland's water regime and ecology. If the wetland is isolated from the aquifer by impermeable soils, then groundwater abstraction will have no impact. In contrast, wetlands fed by rivers may be impacted by surface water abstraction, or operation of dams, sluices or weirs that control river water level. However, quantitative information will be required to determine the magnitude of any impact.

Although it is the presence of water, indicated by a high water table or inundation, for some significant period of time that makes wetlands different from terrestrial habitats, the chemical properties of the water also have a marked impact on wetland characteristics. Wheeler and Shaw (1995) have identified three main environmental gradients that determine the dynamics of a wetland system and are thus key elements in conceptual understanding.

- (a) acidity: ranging from acid sites on peat soils/substrates to base-rich (e.g. coming from a Chalk aquifer).
- (b) fertility (availability of nutrients, primarily N and P): ranging from oligotrophic to eutrophic;
- (c) hydrological regime: ranging from highly variable water level (such as floodplains of flashy catchments) to more stable water levels fed by groundwater.

Consequently, it is the combination of hydrological regime and water quality that determines the ecological character of many wetlands. At North Meadow, on the upper Thames floodplain, annual inundation from the river is important not only because it saturates the wetland, but also because it brings nutrients to the soil. Wicken Fen in Cambridgeshire is being impacted by reduced winter flooding (McCartney *et al.* 2000). However, although this may be the mechanism, the problem is not so much the drying-out of the fen, but more the increased acidity, as the flood water is base-rich (coming from a Chalk aquifer).

### **5.2 Why Conceptual Understanding is Important**

Conceptual understanding is a basic pre-requisite for impact assessments of wetlands; if the interaction between a wetland and its sources of water (in terms of quantity and quality) are not defined, then possible impacts cannot be identified, mitigated or resolved. If conceptual understanding is wrong, then the assessment of impacts and possible solution may be wrong. Sound conceptual understanding is particularly vital where there are multiple impacts that may have compound or in-combination effects. Several of these issues are exemplified by the impact assessment of Shirley Pool in Cheshire. Shirley Pool is a peat bog on the Sherwood sandstone, which contains

important archaeological wood remnants of Bronze Age settlements. The site has become drier and English Nature made an application to take water from a Magnesian Limestone aquifer to keep the site wet. However, it was felt that the pH of this water could be too high to conserve the wooden remains. Desiccation was thought to be caused by deepening of land drains rather than groundwater abstraction; so removing the field drains may be the most appropriate action. Overall, identification of restoration solutions has been hampered by a lack of understanding of the hydrology, hydrogeology, drainage and water quality of the site.

In many cases, our conceptual understanding of how the wetland works will change significantly as data are collected and analysed. This will change the assessment of impacts and possible solutions. An example of this is Pulfin Bog in East Yorkshire; a semi natural 300 m x 200 m wetland that lies within an artificial meander of the tidal River Hull. The Chalk rocks that outcrop to form hills up-gradient of the site are covered with drift deposits at Pulfin (principally boulder clay but also silts, sands and gravels) of up to 40m in thickness. (Figure 5.1) The original conceptual understanding was that the drift separated the wetland hydrologically from the Chalk so that the bog would not be affected by low groundwater levels in the aquifer. However, analysis of borehole and wetland dip well data suggests that this is not the case. Soil cores showed that in places the drift was only 6 m thick beneath the wetland and contained a significant sand fraction. Water level data indicated that levels within the bog are controlled by groundwater head rather than surface water level. As a result of improved conceptual understanding it was recognised that the bog is therefore vulnerable to longer term groundwater droughts and that, in theory, groundwater abstraction could impact on the wetland.

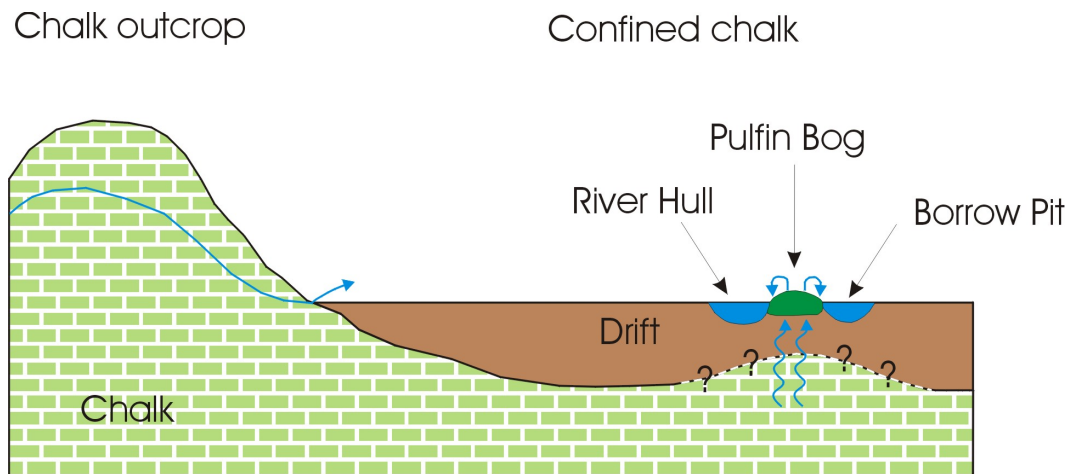

**Figure 5.1: Geological cross-section, Pulfin bog, East Yorkshire (not to scale).**

Conceptual understanding of a wetland system is also vital to interpreting the impacts of indirect alterations to the system. Oak Mere wetland, in Cheshire, lies within a sand sheet underlain by Sherwood Sandstone (Figure 5.2). It was recognised that abstraction from the sandstone aquifer for public supply and from the sand for horticultural use would impact on the wetland. However, a major additional impact has been the extraction of sand that has lowered water levels in the sand sheet due to the interconnection of water bodies, changed the hydraulic gradient and increased evaporation. Water table levels now respond generally to rainfall, so the wetland is very vulnerable to drying during low rainfall periods. Similar problems have also arisen at

Thorne/Hatfield Moors, an SAC/SPA raised mire, where peat extraction was thought to be causing drying-out and degradation of vegetation.

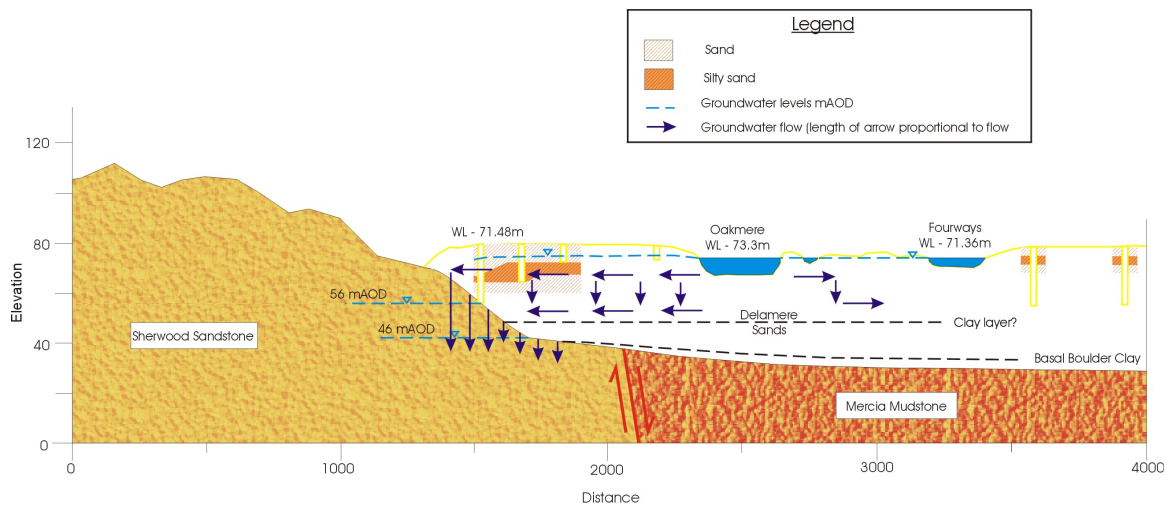

**Figure 5.2: Hydro-geological cross-section through Oakmere**

Wetness within a wetland may be controlled as much by the on-site management of water, as external inputs of water. Internal water levels, held by penning boards, are a feature of many wetlands, such as parts of the Somerset Levels and Moors and Pevensey Levels, where farmers receive subsidies for maintaining high (ecologically beneficial) ditch water levels. In contrast, other sites, such as peat wetland on Exmoor have been impacted by digging of drainage ditches that are designed to lower water levels. Here some ditches had been blocked as a restoration measure. Water levels on Walmore Common floodplain in the River Severn are impacted by ditches (rhynes) controlled by sluice gates. These internal site management measures can mask or even counteract impacts, such as abstraction.

Some impacts may affect part of a wetland and not all of it. So conceptual understanding needs to ensure that a range of impacts in different areas can be assessed. On the Pevensey Levels in Sussex, the eastern part (drained by the Wallers Haven) ditch water levels are impacted by abstraction; in the western part (drained by the Hailsham river), the major issue is water quality and the site is a pilot for a Eutrophication Action Plan, which would target both diffuse pollution from agriculture and sewage treatment works discharges.

Finally it is important to recall that factors other than water quantity and quality may be important in influencing the ecology of wetlands. At Windsor Hill Marsh, Somerset the wetland is being invaded naturally by terrestrial vegetation; the Somerset Wildlife Trust has instigated scrub-clearance to preserve the wetland flora of the SSSI and grazing to keep down future scrub regeneration. The flora of Pevensey Levels is changing due to invasive species, principally the floating pennywort (*Hydrocotyle ranunculoides*). In the Crymlyn Bog, South Wales, the vegetation has become dominated by phragmites reeds and woodland, which may be due to reduced grazing as well as increased wetness.

This study focuses on the hydrological impacts on wetlands.

### 5.3 Conceptual Understanding and Impact Assessment

The preceding discussion demonstrates that conceptual understanding is at the heart of wetlands impact assessment and its importance cannot be overestimated. Conceptual understanding is described by a conceptual model, which can be defined as a synthesis of the current understanding of how the real system behaves, based on both qualitative *and* quantitative analysis of the field data and information. A real hydrological system is so complex that it will never be possible to study everything in detail. A conceptual model is therefore always a simplification of reality, however it will help determine which factors are crucial and thus must be examined in detail.

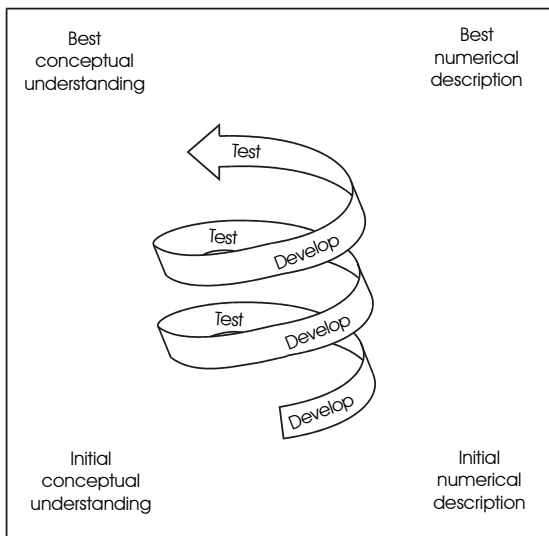

**Figure 5.3: Conceptual model development**

An important feature of the conceptual model is that it must be tested with numbers. This forces hypotheses to be evaluated and alternatives found if necessary. Conceptual modelling is an iterative or cyclical process, illustrated in Figure 5.3. The process of developing a conceptual model is as follows:

- Start with initial ideas, such as observations, hypotheses and areas of uncertainty, and write them down;
- Test the model, by, for example, undertaking some crude water balance calculations;
- Based on the results of the testing, re-evaluate the model, rejecting some hypotheses, keeping some and developing some new ones, as necessary;
- Test the improved model, and then continue the cycle of developing and testing until the initial ideas become the best available conceptual model, as required for the problem to be addressed.

Superimposed on the continuous cycle of conceptual model development and testing is a hierarchical or tiered approach, with basic, intermediate and detailed levels of model. Each tier uses increasingly sophisticated tools for testing the conceptual model. The tiered approach is illustrated in Figure 5.4, within the wider context of impact assessment. It can be seen that the conceptual model is refined within each tier, from an initial understanding to the best available model. The diagram also illustrates that as the investigation progresses through the tiers the data needs and costs increase, but so too

does the confidence in the conceptual model. The point at which the risk has been reduced to an acceptable level, and a decision can be made will depend on the objectives of the study. For example, at highly contentious sites (eg. SACs or SPAs) the degree of certainty may need to be higher than for non-designated sites. The objectives will be determined with or by project partners (such as English Nature), but must be very clear.

For a more detailed discussion on conceptual modelling please refer to Faulkner *et al* (in press).

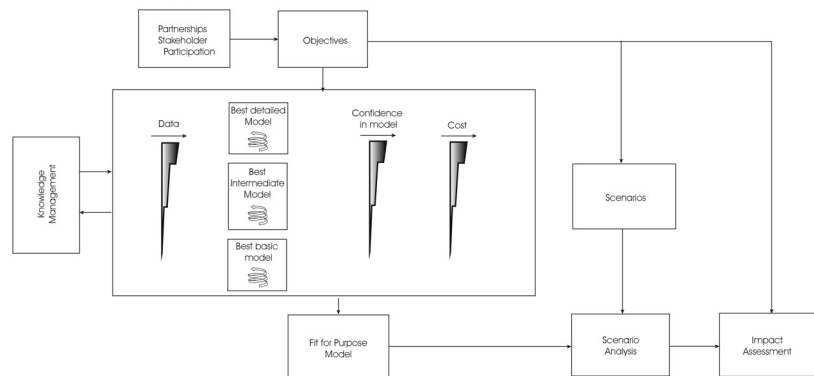
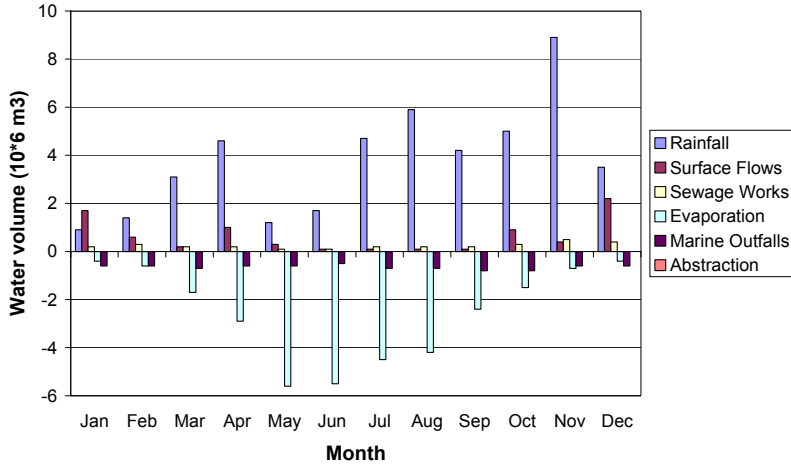

**Figure 5.4: Linking conceptual understanding and impact assessment**

## 5.4 Hydrological Elements

Water sources that support wetlands can be divided into three types: rainfall, surface flow and groundwater. There are key elements in the hydrological system that control which source is the most important at any wetland.

1. **Rainfall:** Few wetlands in the UK are supported only by direct rainfall. However, rainfall can be a dominant component in the hydrological balance, such as on the Pevensy Levels (Figure 5.5). Here as in many other wetlands, land close to ditches is controlled by ditch water levels, whereas the wetness of the field centres is more a reflection of the balance between rainfall and evaporation.



**Figure 5.5: Water balance for Pevensey Levels (after Gasca-Tucker, 2000)**

2. Surface flow: Most wetlands adjacent to water courses, such as floodplains, depend on surface water that is determined by the magnitude, frequency, duration and timing of floods and low flows. An example is Walmore Common, a wet grassland, on the floodplain of the River Severn (Figure 5.6). The site is currently in favourable condition, as floods are broadly natural and inundate the wetland periodically, although reduction in low flows may mean the wetland is at risk during dry periods.

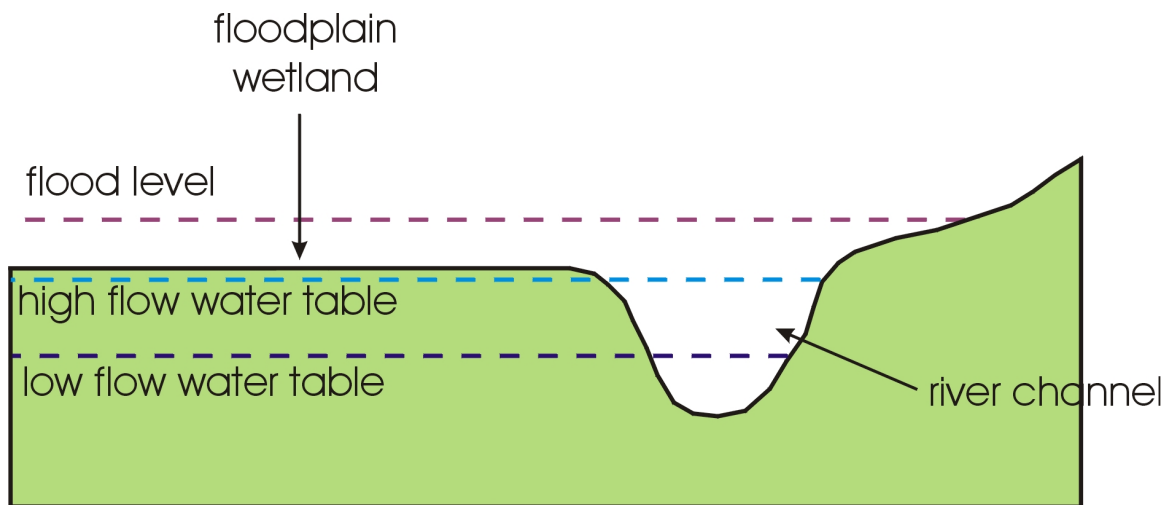
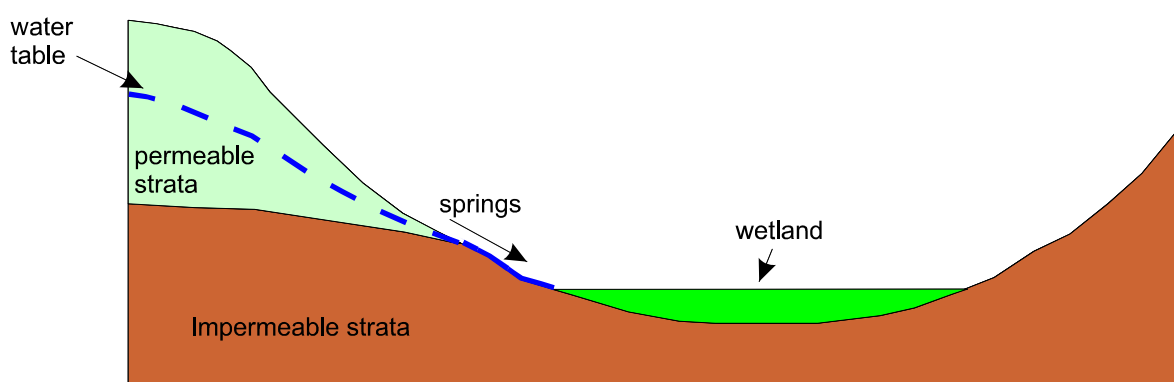

**Figure 5.6: Cross-section of hypothetical floodplain wetland, whose hydrology is controlled by river level**

3. Groundwater: Many wetlands are underlain by aquifers. The extent to which the hydrological regime of any wetland depends on groundwater is determined by the relative water levels in the wetland and the aquifer, and the hydraulic conductivity of the substrate between the two. The substrate may include, for example, glacial till/ Quaternary deposits such as that which overlies much of the Chalk aquifer in

East Anglia, or organic and fine particle material deposited within the wetland. At Ant Broads and Marshes SSSI (a part of the Broads cSAC and Broadland SPA), abstraction for crop irrigation takes place from a shallow sand and gravel aquifer beneath the wetland. Analysis of pumping test results and water level monitoring confirmed that a silty-clay layer between the base of the wetland and the aquifer was acting as a confining layer. This demonstrated that the abstraction was not having an impact on the water levels within the wetland. However, not all wetlands have a substrate between their base and the aquifer, and as such are in hydrological contact with the aquifer eg. Great Cressingham Fen in East Anglia. Such wetlands are therefore hydrologically vulnerable to activities that change water levels in the aquifer eg. groundwater abstraction. Impact assessment is particularly difficult when the geology is complex; ie. where there are many layers (such as clay, sand, Chalk), each of which have their own water table levels, or where the layers are discontinuous and heterogeneous in thickness or conductivity.

In reality, many wetlands are supported by a combination of direct rainfall, surface flow and groundwater. Other hydrological processes may also be important such as springs and shallow groundwater from up-slope. For example, valley bottom wetlands in Devon are sustained by emergent groundwater seepage areas and spring flows from Pebble Bed strata (Figure 5.7). Furthermore, the way a wetland works hydrologically may vary locally so it is not appropriate to transfer knowledge from one site to another.



**Figure 5.7: Hypothetical valley-bottom wetland, whose hydrology is controlled by spring flow from up-slope**



# Birmingham University Wetland Classification

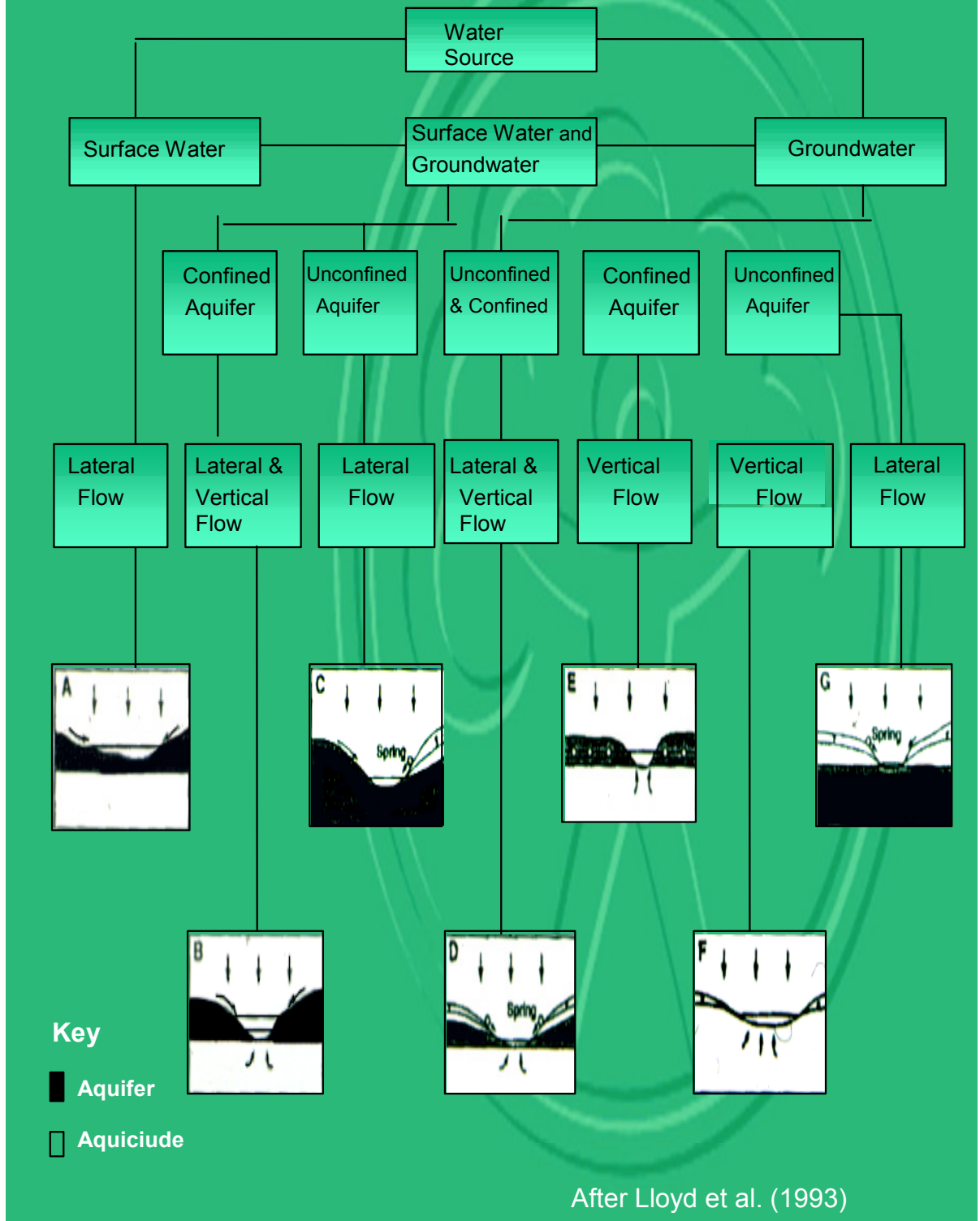

Figure 5.8: Wetland Classification (after Lloyd *et al*, 1993)

Nevertheless, the dominance of either surface or groundwater in controlling wetland hydrology forms the basis of much wetland classification, such as that by Lloyd *et al* (1993), who produced a hydrological classification of East Anglian wetlands, as an aid to assessment of their vulnerability to abstraction (Figure 5.8). Recent Agency research (Wheeler and Shaw, 2000) has focused on trying to identify homogeneous wetland types that are supported by the same hydrological processes and thus respond in a similar way to external or internal impacts. Further details can be found in section 3.7 – Wetland Framework.

## 5.5 Developing Conceptual Understanding

Despite the complexity of wetland systems, there are various techniques available with which to develop conceptual understanding. Some examples are given below.

- Analysis of hydrological data

Analysis of rainfall, river flow, groundwater, soil water and evaporation data can provide a good insight into the hydrological links between wetlands and their wider environment. For example graphs may exhibit a strong relationship between wetland soil water level and underlying aquifer level. Gilman (1994) and Gavin (2003) provide details of data collection and analysis techniques supported by case studies.

- Pumping tests

Pumping tests are a commonly used hydrogeological technique for assessing the response of an aquifer to pumping, and learning about the behaviour of the aquifer. It can also be used to determine the properties of both regional aquifers and wetland soils. It integrates conductivity from rocks or soils around the borehole and thus represents an average value in the case of heterogeneous aquifers. Pumping test and other field data can be used in conjunction with models to make predictions about possible impacts on wetlands.

- Geophysical techniques

Techniques such as ground penetrating radar (GPR) are used for geological and archaeological surveys. The instrument is towed behind a Landrover or tractor (so access is an issue) and is able to detect junctions between different soil and rock types, hydraulic conductivity of different layers and water table depth. Another technique is electrical resistivity tomography (ERT) which measures variations in the electrical conductivity (resistivity) of the earth to identify regions of different physical and/or chemical properties. In situ rock conductivity depends on the nature of the rock (crystal structure, porosity, impurities, weathering) and environmental conditions (moisture content, temperature, pressure) and may vary widely, even within similar lithological groups. GPR has been used by the Agency at the sand dune system at Sefton Coast, a 'wet slack' environment, and resistivity was used in the Eden Valley to investigate the thickness of peat/drift supporting Cliburn Moss, a SSSI, sitting above the Penrith Sandstone. These techniques have the advantage that they are not intrusive, therefore could be useful for delineating clay layers prior to drilling.

- Laboratory analysis

Samples of substrate or aquifer rocks, extracted by drilling or augering, can be analysed in a laboratory to determine particular properties, such as hydraulic conductivity. It is assumed that the sample is representative of the rock or soil as a whole; however samples will often not include preferential pathways for water such as cracks, fissures or natural soil pipes that lead to a field scale hydraulic conductivity many times that of the sample.

- Water chemistry analysis

Water chemistry changes as water passes through soils and rocks. For example, rainfall may be slightly acidic, but water becomes alkaline, with high levels of calcium, after contact with Chalk rocks. Chemical analysis may be used to identify water sources for wetlands. Kent Area (Humphreys and Kellet, 2003) was able to use chemical samples to differentiate those wetlands fed by Chalk springs (Luddenham, Teynham and Faversham) from those fed by water from tertiary deposits (Boughton and Halstow).

- Isotope analysis

Some naturally occurring elements, such as oxygen, exist with different atomic masses, although they possess the same chemical properties, for example oxygen 16 and 18 ( $^{16}\text{O}$ ,  $^{18}\text{O}$ ). The ratio of these isotopes occurring in natural waters can be changed by environmental processes, e.g. water molecules with lighter oxygen isotopes are preferentially evaporated. The dominant water source for a wetland can be determined by comparing the isotope ratio of its water with that of rainfall, river water and groundwater. The disadvantage is that specialist equipment is required and analysing samples can be expensive. Information on the principles and applications of isotopes in hydrology can be found in Mook (2001).

- Modelling

As described above, models should be based on a pre-defined conceptual understanding of the system under study. This conceptual understanding is then often tested using the model, provided that other sources of model error, such as poor data, are accounted for. Models can range from simple spreadsheet models to complex 3-dimensional finite-element groundwater models. Whatever the model, it is important to recall that the model is only as good as the conceptual understanding and degree to which the model actually represents the processes at work in the system. All outputs from models must be interpreted in the light of the level of understanding and the type and structure of the model. This issue is expanded in section 6.4 below.

## 6. ISSUES IDENTIFIED

A key element of this project was to review the impact assessments that had been undertaken or were planned by Agency operational staff. In particular the project aimed to determine the Agency's business needs for impact assessment and the approaches taken. A series of 5 meetings were held:

- Solihull 7 April 2003 - staff from Midlands, Anglian and Wales
- Leeds 12 May 2003 – staff from North West and North East
- Wallingford 23 May 2003 – staff from Thames
- Worthing 25 June 2003 – staff from Southern
- Exeter 2 July 2003 – staff from South West

The meetings were attended by representatives of all 8 regions, plus various members of the project board. In addition, Felicity Miller and Mike Acreman attended the Kent Wetlands Group Meeting on 26 June 2003. Attendees at meetings were identified by a combination of phone calls and E-mails to staff who were thought to be involved with impact assessment of wetlands and discussions with focal points, such as Habitat Directive Coordinators and team leaders.

Questionnaires were sent to staff in advance. These contained questions on the type of wetland and impact, data collected, methods used for assessment, who was involved, and any problems/issues that arose. In all, 32 questionnaires were returned; these are presented as Annex 2. Note that the questionnaires provide representative case studies illustrative of the issues encountered. They do not provide an exhaustive list of sites at which an impact assessment has been carried out.

At each meeting, staff made short presentations on key impact assessments that they had been involved with, highlighting important issues and experiences. These were analysed to identify key problems and gaps in current practice, and are expanded in the following eight sections. Recommendations for further work are made at the end of each section. Some of these will be taken forward in Phase 2 of this project.

**Table 6.1: Broad areas of business need for the Environment Agency**

<ol style="list-style-type: none"><li>1. Conceptual Understanding</li><li>2. Objectives of impact assessment</li><li>3. Data and monitoring</li><li>4. Assessment tools</li><li>5. Assessment guidance and procedures</li><li>6. Restoration and mitigation</li><li>7. Partnerships, project management and funding</li><li>8. Knowledge management</li></ol>
---

## 6.1 Conceptual Understanding

Operational staff within the Agency, who were involved in the project meetings, felt that the biggest problem in impact assessment of wetlands was lack of conceptual understanding of how wetlands work. It was recognised that assessments cannot be undertaken without good conceptual understanding and that incorrect understanding may mean that results are invalid. This issue has been widely described in Chapter 5.

Staff recognised that whatever the assessment technique used, the results and implications must always be viewed within the framework of the conceptual understanding of the wetland and its relationship with the surrounding catchment or aquifer unit. This is particularly important where, for example, the geology is complex, where there are many substrate layers (with each having their own water table level), or where layers are variable in thickness or hydraulic conductivity. In such cases conceptual understanding and the derived models employed will inevitably be a gross simplification of the real system.

Perched water tables, or where springs upslope feed valley bottom wetlands, form another area where conceptual understanding is limited, but the Agency is still required to undertake assessments. For river floodplain wetlands, it is clear how floods provide the primary water source, nutrients and often regulate pH, but the role of low flows in maintaining floodplains (and hence the impact of altering low flows) is not well understood.

A further issue highlighted by Agency staff is the need to understand compound effects or in-combination impacts. For instance, where several abstractions in the vicinity of a wetland are being assessed, it is difficult to understand the effects that individual abstractions are having, especially when they are in different aquifers e.g. sand, gravel and Chalk.

Conceptual understanding also needs to include internal impacts of site management, such as operation of water level control structures. These may mask or counteract external impacts, such as abstraction.

Finally, a key part of conceptual understanding is to recognise natural variability in the hydrological system, as wetlands may operate differently in, for example, droughts and wet periods.

### **Recommendations (1)**

A review of current approaches to wetland classification should be undertaken, particularly past work by Lloyd and Tellam and current work by Wheeler and Shaw, and, if appropriate, a system that captures our conceptual understanding should be recommended. If no such classification exists, a new one should be developed.

Guidance and training should be produced for Agency staff on how to develop conceptual understanding of wetlands and their hydrological environment. This should include sections on the following:

- techniques for identifying the contribution of various water sources, such as geophysical surveys
- complex geology, where there are many substrate layers (with each having its own water table level), or where layers are variable in thickness or hydraulic conductivity.
- perched water tables, or where springs upslope feed valley bottom wetlands
- relationship between floodplains and low river flows
- natural hydrological variability

This guide should link with the Monitoring guide recommended in (3) below.

## **6.2 Objectives of Impact Assessment**

As indicated in Chapter 2, the Agency is undertaking impact assessments of wetlands in response to many different drivers. These drivers may have different objectives, or may relate to different interest features. The RSA Programme, which covers all wetlands, embraces the broad objective of the Agency, which is to balance the needs of abstractors and those of the environment. However, different legislation relevant to different sites may add more or less weight to ecological considerations. For example, the Habitats Directive aims to maintain or restore wetlands to 'favourable conservation status', which may be natural or artificially maintained by pumping or control of water levels by sluice, whereas achieving "good ecological status" required by the Water Framework Directive is more closely linked to naturalness. Different drivers may also have different time-scales and procedures. In any assessment the Agency must be clear what question is being asked and what the priority should be in any conflicting objectives. At Great Cressingham Fen impact assessment focused on flow and water table requirements of what was perceived as the most sensitive habitat feature, ie. M13 (*Schoenus nigricans*-*Juncus subnodulosus* mire). On Thorne/Hatfield Moors (an SAC/SPA raised mire) peat extraction was thought to be causing drying-out and degradation of vegetation. However, desiccation had created a suitable habitat for the night jar. The target hydrological regime would need to be different in the mire restoration areas from those in the night jar habitat.

Many programmes within which the Agency is involved provide the opportunity for integrating water management for people and the natural environment. On the River Idle washlands, a wet grassland that had been reduced from 250 ha to 88 ha. due (according to English Nature) to a flood defence scheme, the development of a Water Level Management Plan has provided a mechanism for coordination of conservation

and flood management. CAMS, CFMP and RSA also provide opportunities for balancing wetland conservation and direct human use of catchments. However, there is a lack of an overall framework for achieving desired conservation objectives. Issues tend to be picked-off in terms of impact assessments (through water resources, flood defence or conservation) according to the relative importance of the driver (e.g. statutory, non- statutory) and to what resources are available; there is a lack of coherence between the drivers that might provide an integrated solution to the issues. Responding to the requirements of the Water Framework Directive may provide this holistic approach.

Although there is much legislation and many programmes and initiatives driving assessments, they do not always provide a framework for a solution. For example, in the eastern part of the Pevensey Levels wetlands, flows in the Wallers Haven catchment are impacted to a very minor extent by groundwater abstraction, but to a greater extent by surface water abstraction. The reduced ditch water levels in the wetland, which have resulted from abstraction, could be mitigated by repairing and up-grading sluice gates at the lower end of the catchment. This would allow increased flexibility for achieving sustainable abstractions. However, although there may be a direct gain in terms of water availability, it may not be appropriate for a water company to fund these measures; the legal position seems unclear, and staff were unsure how to progress the issue.

Addressing many issues in wetlands involves a specific active action, such as reducing an abstraction or altering a weir height. Many wetlands in the UK are in some way artificial and exist because of past engineering. Wetland conservation may thus mean maintaining certain infrastructure. "Doing nothing, i.e. allowing a structure (such as a sluice) to fall into disrepair and thus impacting on a wetland, may put the Agency in breach of legislation such as the CRoW Act. Many staff are unclear on the position.

Assessments at many sites are undertaken because of some evident or perceived degradation of ecological character. However, even for sites that are currently in favourable condition, such as the Arun valley wetlands in Sussex, assessments are often needed to predict the impacts of possible future scenarios. In the Arun, the current actual abstraction from the underlying Folkstone beds is roughly equal to the recharge rate, but the full licensed abstraction amount is 2.5 times the recharge. If the full licensed quantity were to be abstracted this would most likely cause a significant impact. The objectives therefore need to consider possible future situations as well as current issues.

The Agency may face particular difficulty in the future in assessment of environmental mitigation measures. Warmwell Heath in Dorset contains a series of mire that are situated on Tertiary deposits which separate them hydrologically from the underlying Chalk (Figure 6.1). The headwaters of the Tadnoll Brook receive Chalk groundwater baseflow, but flow in the brook is also augmented by water pumped from the underlying Chalk for public water supply and to feed a fish farm. Flow is now perennial, whereas it was previously ephemeral (a winterbourne). Rainfall on top of augmented flow leads to inundation of marginal wetland areas. This has enhanced the environment and even though artificial, the site is now designated under the Habitats Directive. Under the new Water Bill all such abstractions will need to be licensed. This example raises important questions about the sustainability of such schemes and the relationship between habitat conservation and naturalness.

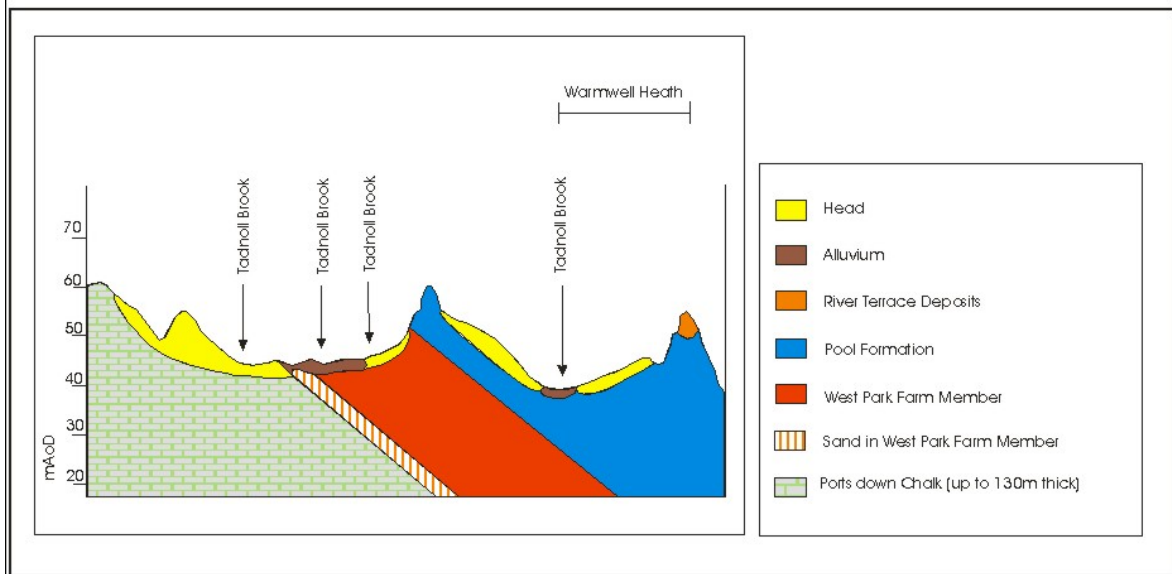

**Figure 6.1: Geological cross-section through Warmwell Heath**

It is a characteristic of many wetlands that in their natural state they are transient features of the landscape; infilling with sediment and being colonised by progressively more terrestrial vegetation. For example, the invasion of alder and willow in the Dorset Heath fens is a natural process being halted by site management. In an ideal world, conservation planning and management would be undertaken at a landscape or catchment scale, such that as some wetlands would be allowed to disappear by natural processes, they would be replaced by others being naturally created elsewhere. However, conservation is currently primarily restricted to designated sites, although the Water Framework Directive is proposing good ecological status of all water bodies and management at a catchment scale. In practice, conservation will remain site based and protection of sites may become increasingly difficult and will require more active management in the face of climate change. This requires increased clarity of the objectives for sites, as restoration to a truly natural condition is rarely an option in the UK. In the inner Thames Marshes in East London, 300 hectares of wetland have recently been acquired by the RSPB from the Ministry of Defence, who used the site as a firing range. The site is separated from the Thames by a sea wall and supports a range of species, including wild fowl, waders, macro-invertebrates, water voles and bats. A major question was to define a base-line for restoration. Should this be 100 years ago, just before the sea wall was built or just after?

### **Recommendations (2)**

Operational staff would like the Agency to provide guidance on a range of issues related to setting and achieving objectives for various drivers. These include:

- Implications of the “do nothing” option and how this varies between different situations;
- How to resolve conflicting interests (eg. people v wildlife);



- How to set and prioritise objectives for a site especially when different drivers appear to conflict.
- In many cases these will involve dialogue with interested parties.

### 6.3 Data and Monitoring

Even where there is already good qualitative conceptual understanding of a wetland, sound impact assessment relies on quantification of the hydrological processes that both maintain the wetland and that may be influenced by external or internal change. In the meetings with operational Agency staff, lack of data and paucity of knowledge on what data to collect were identified as the key limitations for impact assessment. For example, very few data were available for any of the 43 separate SSSIs on the Dorset Heath European Designated Sites that needed assessment. Certain wetland types, such as floodplains supported by shallow (often gravel) aquifers, including those in the upper Thames, were highlighted as lacking data, and evaporation was often considered the greatest unknown in the water balance, such for the Marazion marshes in Cornwall. Many staff found it difficult to plan monitoring especially on large heterogeneous sites, such as the mosaic of wetlands and other habitats that occur on Dartmoor with the National Park.

In most areas of England and Wales, general hydrological information is available. Groundwater level data are often available for major aquifers, rainfall data for a region and average evaporation figures for 40 x 40 km grid squares are provided by the Meteorological Office. However, these data are often inadequate and too general for detailed impact assessments at individual wetland sites, which require a water balance and quantification of different water inputs and losses.

Overall, key hydrological data types needed for impact assessment include rainfall, inflow, outflows, evaporation and water table level data (both in the wetland soils themselves and in any underlying aquifers). Where possible additional data, such as barometric pressure, should be recorded, as this affects water table levels. In general, water quality monitoring has tended to be neglected, but water quantity requirements cannot be separated from nutrient levels. For example the upper Thames floodplains, such as North Meadow, require periodic inundation as much for the nutrient brought by the flood waters as for the water itself, (see Lowland Wetland Guidelines prescription for MG4). The exact types of data required and their collection frequency depend on site conditions. Short time step (e.g. 15 minutes) data are needed at some sites, especially where surface water dominates (here data loggers have proved invaluable at many sites), or where diurnal pumping operations occur, whereas fortnightly data are adequate for slowly responding systems, often fed by groundwater.

Another problem is that long-term data (more than 20 years) are needed, covering droughts and wet periods, to be able to put short-term records into a historical perspective. Without these data, it is very difficult to develop understanding of natural variability in wetland systems. In most cases, monitoring is only initiated once a problem has been identified, but impact assessment really needs pre-impact baseline data. At Pulfen Bog in East Yorkshire, wetland degradation had been noted during several years of drought. However, long term data (despite gaps and suspect individual observations) showed that abstractions were small in relation to natural climatic

variability and so were thought to have little impact on the wetland. Indeed the wetland recovered significantly during a recent wet period. This demonstrates that falling water levels are not necessarily due to abstraction, but may just be a feature of natural variability. In addition, post project monitoring is needed to appraise objectively the success of any actions and this has not always been undertaken.

A solution would be to develop a national network of wetland monitoring sites where key variables were recorded systematically over a long term. Much experience has been gained in Anglian region, where a network of 51 hydrological monitoring sites was established in 1996. Ideally sites should include both those that are impacted and those that are in good condition. This would provide a more strategic approach to wetland monitoring rather than waiting until data are needed at a site for an assessment, when it may be too late to start recording. Another major problem is that wetlands are unique and transfer of data from one site to another is problematic.

A more practical solution may be to train and support reserve wardens and/or Agency staff to collect data that are easy and inexpensive. Several monitoring reports have been produced by the Agency (Environment Agency, in press; Gavin, 2003) and these could be assimilated to produce consolidated guidance for site owners. There are several relatively cheap and quick means of data collection that can be useful. However, even these can be thwarted by problems. For example, gauge boards can be installed to measure water levels in wetlands. However, the board may rise and fall as the soil (in many cases peat) expands and contracts as it is saturated and then dries out. Some installations have one or more fixed bench marks, usually a metal rod that penetrates consolidated substrate beneath the wetland, such as clay, at the base of the peat. The gauge board is then periodically levelled into the bench mark to check its absolute elevation. Several Agency staff highlighted the benefits of simple and inexpensive, rapid surveying of sites. Identifying flow directions, blockages in ditch networks, or augering to examine soil properties were all possible within a short field visit. Local knowledge of the site managers was also felt to be an important source of information, although anecdotal accounts need to be treated with care. Advice on site assessment, equipment installation, such as putting dip wells into the peat, has been provided by research organisations and some basic references exist (eg. Gilman, 1994, Gavin 2003).

In addition to published reports there are numerous examples of good practice developed by the Agency that have not been well disseminated. Anglian region established monitoring at many wetlands, including Weston Fen, and have good experience on the layout and construction of piezometers for assessing the impacts of groundwater abstraction, including which horizons to take head measurements/water levels from, and which intervals to screen. In cases where the geology is more complex, such as the Kennet and Lambourn catchments and associated wetlands, piezometers may be required into many different strata (Chalk, Greensand, clay, gravel, peat). In all cases, location, depth, screening and installation techniques must all be selected carefully to produce useful data.

Figure 6.2 shows a possible layout for monitoring to assess whether a wetland may be impacted by groundwater abstraction. In this hypothetical case, the main issue is whether a superficial layer separates the wetland hydrologically from the Chalk aquifer. The layout includes: (1) two piezometers near to the groundwater abstraction site, to assess direct impact (2) two similar piezometers near to the wetland, to determine

impact below the wetland (3) dip wells into the wetland to assess the actual impact on wetland water levels. The Figure is not intended to show all construction details, but the deeper piezometers would be cased through the superficial deposits to measure hydraulic heads in the Chalk. The dip well in the peat would be measuring open water level. Where the superficial deposits show distinct stratification eg. gravel and till layers, addition piezometers into each layer would be required.

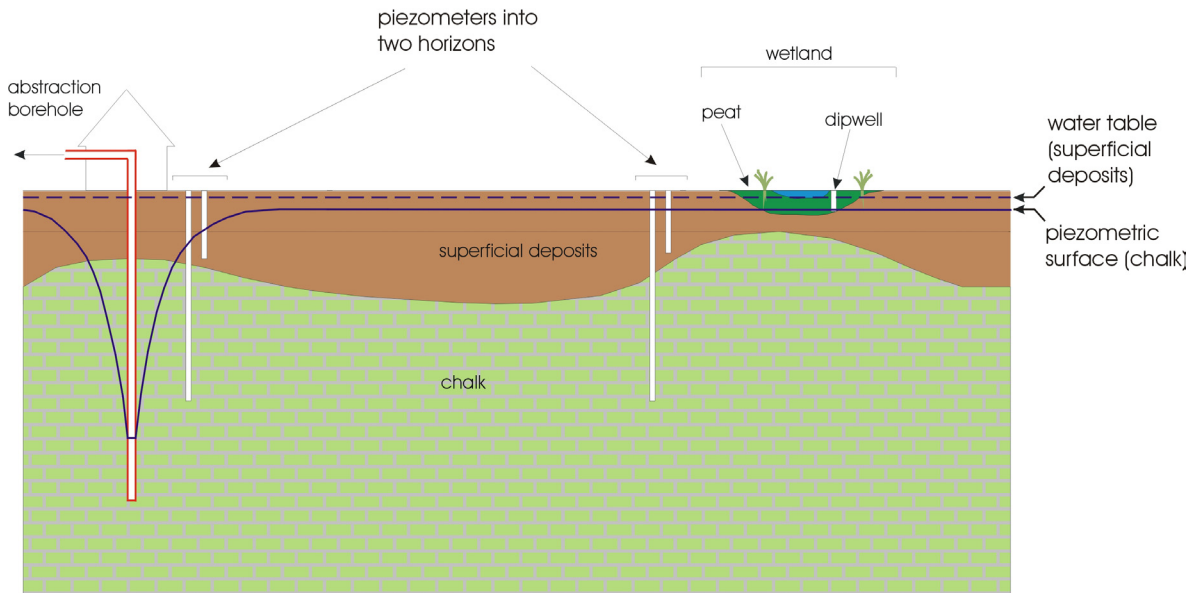

**Figure 6.2: Possible layout of piezometers for assessment impacts of groundwater abstraction on wetlands fed by underlying aquifers. Superficial deposits may be a mixture of materials such as sand, gravel and clay.**

In recent years, data are increasingly being collected using remote sensing techniques. The most widely used are methods for determining spatial variations in surface elevation to produce digital topography, such as Laser Induced Direction and Range (LIDAR). This is operated from an aircraft and produces a 1 x 1m grid of spot heights to a claimed vertical resolution of 0.1m. It has been used by the Environment Agency for flood risk maps. Topographic maps can also be produced from satellites equipped with Synthetic Aperture Radar (SAR). LIDAR has been used to model floodplain wetlands (Marks and Bates, 2000). However, the vertical resolution of both LIDAR and SAR are inadequate to define the subtle relief in many wetlands. The System for Hydrology Land Observation for Model Calibration (SHYLOC) includes a remote sensing technique that provides estimates of water levels within wetland channels from Landsat TM satellite images. This was tested on Elmley Marshes, North Kent (Al-Khudhairy *et al*, 2001). The method provides good results but is time consuming to setup and calibrate.

Discussions with Agency staff highlighted four types of hydrological data that are in particularly short supply.

1. Vertical leakage rates from wetlands. As highlighted in section 5.1, the degree of interaction between a wetland and any underlying aquifer in response to a specific

pressure is controlled by the relative water levels, the hydraulic conductivity and the thickness of sediments at the wetland/aquifer interface. Where possible, simple look-up tables of hydraulic conductivity for typical soils types and aquifers should be developed for use as a default where no other data are available.

2. Water requirements of wetlands. Water regime requirements of 16 different wetland plant communities are being addressed, at least partially, by the Ecohydrological guidelines project (see Section 2.1). This work needs to be extended to other vegetation types, such as wet woodlands and upland raised bogs. In addition, there is an increasing number of impact assessments being undertaken at coastal sites and the freshwater needs of coastal wetland ecosystems remains a key requirement.
3. Evaporation is known to dominate the water regimes of many wetlands. Evaporation rates can be high in reedbeds (Fermor *et al*, 2001) and can vary greatly between different vegetation communities (Acreman *et al*, 2003). Guidance is needed on what equipment to use, for example at Crymlyn Bog in South Wales, an automatic weather station was installed to collect data to estimate evaporation. Methods are required for using available data (e.g. from MORECS or nearby meteorological sites) and how these can be adjusted for different wetland conditions. Look up tables for typical wetland plant communities would be useful as default values; if precise values are unknown. Even ranking of land cover types (such as forests, wetlands, agricultural land, open water) according to their evaporative rates could provide useful information for impact assessment. The guidance should include details of how evaporation changes with different water level regimes.
4. Losses to the sea. On many coastal wetland systems, such as the Swale marshes in Kent, water loss from the wetland through tidal flaps is a major component of the water balance. Normally there are few data and so there is little information on how much water is lost from the system. Quantification would require water levels to be measured on both sides of the structure and hydraulic equations applied according to the flap dimensions and mode of operation, although this may be irregular. Tidal levels may be available from near-by tide gauges.

However, in spite of all the problems with data collection, even small amounts of data can be very useful in impact assessments. For example, when studying the blanket peat in the South Pennine Moors, where there are many small abstractions near by, data from Yorkshire Water boreholes indicated that the aquifer level was lower than the water table level in the wetlands. Thus the wetland water levels were unlikely to be supported by the aquifer and groundwater abstraction was unlikely to have an impact. Likewise at the Moors SSSI wetland at the head of the River Hamble, fed by springs from the Chalk, there were no dip well or baseline ecological data available. Data were available from observation boreholes near to the springs, and a flow gauge in the Hamble, below the wetlands. A study showed that when an abstraction borehole near to the wetland is operated (normally only in droughts) the water table level drops by 4 metres and the flow in the Hamble reduces by more than 50%, suggesting a major impact on the wetland.

### **Recommendations (3)**

A consolidated guide to designing and operating wetland monitoring should be produced for Agency staff. This should include best operational practice within the Agency, including simple techniques. It should include a route map (e.g. see flowchart in Lloyd and Tellam 1995) for planning site investigation. Particular focus should be on what data to collect (e.g. groundwater heads from different layers) and on the frequency of data collection (e.g. hourly, daily or weekly). Outputs should also include a leaflet for site owners on what standard data should be collected where possible at all sites.

A scoping study should be initiated to consider the feasibility and requirements for producing look-up values for leakage/hydraulic conductivity at the wetland/aquifer interface. This should include details of what is known and what needs to be researched.

Current knowledge on evaporation rates from different wetland vegetation communities should be reviewed and where possible, look-up tables of default values should be reviewed. Guidance is needed on how to estimate evaporation from different methods.

Work on water regime requirements of wetland plant communities should be extended to other inland vegetation types e.g. raised bogs, wet heath, wet woodland and to coastal wetlands.

## **6.4 Assessment Tools**

There are many types of tools available to assist with impact assessment of wetlands. These range from simple spreadsheet-based water balance models to complex multi-dimensional hydro-dynamic models of surface and groundwater flow. Nevertheless, simple graphical analysis can be very revealing and can provide a solution in itself or valuable information before detailed modelling is undertaken. Graphs of groundwater level against stream flow were employed to assess the impacts of abstraction at Great Cressingham Fen and at the Moors SSSI wetland, at the head of the River Hamble in Hampshire.

Hydrological models used in impact assessment of wetlands can be divided into five types.

### **1 Simple conceptual water balance models**

These are often based on computer spreadsheets, such as PINHEAD, that was produced for the Pevensy Levels in Sussex, to relate ditch water level to spatial extent of flooding (Gasca-Tucker and Acreman, 1999). For groundwater fed systems, spreadsheet models often incorporate standard analytical equations, such as the Theis equation (Theis, 1935). This was used at Weston and Great Cressingham Fens as a coarse screening method. The Theis equation requires values for hydraulic conductivity and storativity of the aquifer to determine the impact of abstraction at different rates and distances, on water table levels. This type of approach normally only provides very approximate indications of impacts and is frequently used as a screening technique.

2. **One dimensional hydro-dynamic models**

One-dimensional surface flow models are widely used to determine the water level in a river channel or wetland for a given flow discharge. These can model changes in channel geometry and operation of structures. For example, MIKE II was used to determine the impacts of barrage operation and surface water abstraction on water levels in the lower Derwent river and its floodplain (the Derwent Ings). ISIS was employed to assess the impact on inundation of the floodplain and downstream towns of restoring the channel of the River Cherwell in Oxfordshire (Acreman *et al.*, 2003). ISIS and MIKE II do not explicitly include movement of water through floodplain soils and are hence most applicable to clay based sites where infiltration is minimal.

3. **Two-dimensional models based on land drainage concepts**

Much of the basic soil physics theory that underlies these models is described by Youngs *et al.*, (1989; 1991). Most wetland studies at the field scale to simulate the water table levels have been undertaken with this type of model. Examples include FDRAIN on the Somerset Levels (Armstrong *et al.*, 1980; Armstrong, 1993) and DITCH (an adaptation of FDRAIN) on South Lake Moor Somerset and Halvergate Marshes, Norfolk (Armstrong and Rose, 1999). Similar models have been used in the USA (DRAINMOD – Skaggs, 1982) and The Netherlands (SWATRE - Belmans *et al.*, 1983).

4. **Three-dimensional groundwater models.**

These include MODFLOW, which has been used to model water table levels within several wetlands, including: Pevensey Levels (Bradford and Acreman, 2003); Badley Moor (Gilvear *et al.* 1993); Weston Fen (Lloyd and Tellam, 1995); Narborough Bog (Bradley, 1996); Catfield Fen, Norfolk (Gilvear *et al.*, 1997); Great Cressingham Fen (ENTEC, 2003). A similar model AQUA3D has been employed at Thorne Moor (Bromley *et al.*, 1999). Detailed groundwater models, such as MODFLOW often provide the only solution to understanding the relationship between wetlands and complex regional aquifer systems such as the Chalk, Greensand, clay, gravel and peat that underlie the wetlands of the Kennet and Lambourn catchments. In this assessment, groundwater modelling has helped identify which parts of the catchments are most impacted. However, groundwater modelling is always a simplification of reality, and there is frequently insufficient data to construct an accurate model of the geology, particularly where layers vary in thickness and hydraulic conductivity. In addition, the predictions of groundwater level in a wetland given by a groundwater model, may range over the tolerance of many different types of vegetation.

5. **Catchment distributed models.**

Attempts have also been made to model entire catchments, (including surface runoff and water movement in the saturated and unsaturated zones) containing wetlands, using spatially distributed models. The MIKE-SHE modelling system combines surface and sub-soil flow and has been used for modelling the North Kent Marshes (Al-Khudhairy *et al.*, 1999) but this model requires considerable data and expertise in calibration and running.

Despite the wide range of models available, many are not applicable to impact assessment at the local scale. A major problem is that many tools are not sensitive

enough (i.e. their resolution is too coarse) or data cannot be collected to allow the model to represent effectively the key processes involved in assessing the impact. For the Thames Marshes in East London, a 300 ha former grazing marsh, consultants undertook level surveys and produced an ISIS hydrodynamic model of the site to assess the extent of flooding within the wetland and the risk to surrounding properties. However, the model did not represent local effects, such as blocked ditches, which seem to be a major factor in determining those areas of wetland and properties that get flooded. Similar problems of lack of sufficient resolution meant that the Agency did not embark on detailed modelling of the Brading Marshes, on the Isle of Wight, to determine the impact on flood risk of increasing water levels to restore fringing areas of the wetland.

Scale is also an important consideration when using 3-D groundwater models. If an aquifer, whose areal extent is many 10s of kilometres, is represented by a grid (e.g. 200 m x 200 m), then a small wetland (e.g. 500 m across) overlying the aquifer, would be contained within a few grid squares. Thus subtle variations in water level, hydraulic conductivity etc. over a few metres, would not be modelled.

Wetland impact assessments often need to be undertaken at short notice and with limited funding. As a result operational staff have highlighted the need for a desktop tool that can be applied relatively rapidly and cheaply to help develop their conceptual understanding of the wetland, and quantify the impact of a specific action, such as a groundwater abstraction. This would plug a gap between simple spreadsheet based analytical tools, and fully distributed numerical models. Nonetheless, wetlands are complex systems and there will be a trade-off between rapidity/cheapness and accuracy/confidence in the results. It is noteworthy that Government guidance requires the Agency to take a risk-based approach and a tiered approach would fulfil this.

It is also worth noting that some wetland impact assessments concern very specific issues, and as such cannot be represented by a model. An example is the assessment of mining subsidence in the East Kent coalfield that affects Hacklinch Marshes at Sandwich Bay.

With so many different tools available for analysis of wetland data, operational staff are uncertain as to which models are most appropriate for impact assessment of different wetlands. Clear and concise guidance is needed on the advantages and limitations of the various methods, the data that are needed and the improvement in accuracy that can be obtained by collecting extra data, such as long time series and spatial heterogeneity. Additional guidance is required on establishing and testing scenarios, such as abstraction options.

#### **Recommendations (4)**

A review should be undertaken of the methods and tools available to carry out assessment of the anthropogenic impacts on wetlands, highlighting best practice in the Agency as a basis for a consistent approach to assessment. This should include guidance on the skills and resources needed to use each method, their data needs and the improvement in accuracy that can be obtained by collecting extra data, such as long time series and spatial heterogeneity. The tools reviewed should be incorporated into a hierarchy for assessment, starting with simple analytical methods and ranging up to more complex numerical models.

The feasibility of producing a desktop tool for wetlands impact assessment to plug the gap in the hierarchy between simple spreadsheet tools, and fully distributed numerical models should be investigated.

## 6.5 Assessment Guidance and Procedures

As indicated Agency staff are faced with undertaking impact assessments of wetlands for many different reasons. Some are part of strategic systematic process, such as the Habitats Directive assessments, whilst others arise due to evidence of site specific degradation highlighted by, for example, a Wildlife Trust. Different approaches to assessments are developing in different Agency regions and areas depending on the type of wetlands, the nature of the impact and the skills and experience of the staff.

There is currently no agreed procedure for including wetlands within CAMS. However, an approach has been developed for the Stour in Kent, which includes sub-catchments, e.g. the Stour Marshes, which are dominated by wetlands and managed by control of levels rather than flow. In addition, a review has been undertaken for the Agency of the methods used to assess water resources availability in fenland areas and how these can translate into abstraction licensing policy and practice (Simons and Clarke, 2002). The proposed approach parallels that adopted in the RAM Framework by focusing on modelling fenland water levels against levels proposed for ecological protection. However, further work is needed to trial the proposed methodology in practice, and to revise the ecological weighting aspects for level controlled systems as opposed to flow, before it can be adopted.

An over-arching assessment framework for wetlands impact assessment is required that takes staff through the various steps involved, including conceptualisation of the hydrological systems, evaluating objectives, data collection, data analysis, modelling and final assessment of impacts. Tools should include a range of approaches from rapid screening techniques to detailed models. The framework needs to be generic, recognising that each wetland will have unique characteristics, so that it can be tailored to specific sites. The Wetland Framework studies of Wheeler and Shaw (2000) and the follow-up project may make a substantial contribution to this but the outputs need to be disseminated to operational staff. The eventual framework needs to include a step-by-step guide and checklist and to make use of best practice in the Agency illustrated by case studies. It should be a risk-based approach that allows for uncertainty and includes the likelihood of the impact, for example if it only occurs during drought years.

Particular emphasis in the framework needs to be paid to evaluating various possible causes of impacts to wetlands. Abstraction is often first to be blamed but does not always cause the greatest impact. For example, relatively small activities, such as back filling of trenches dug for highways or pipelines can change hydraulic pathways depending on fill material used. This can have a major effect and is often exempt from planning so the Agency is not informed. At Taw Marsh in Devon, a peat wetland fed by outflow from gravels overlying granite, 13 shallow boreholes, with radial collector pipes, had been dug in the 1950s for water supply. It was reported that the area had been marshy before abstraction started. However, the marsh did not return to its former wet condition following decommissioning of the boreholes, except where clay lenses



supported a perched water table. It is thought that the heavy machinery used to drill the boreholes may have compacted the ground. In the Braunton sand dune wetlands, Devon, where water tables are controlled by variations in lithology e.g. clay lenses, many possible causes for changing water levels have been registered, such as abstraction for golf course watering, but climate was identified as the most important driver. Invasive species were also an issue, but of a much lower order.

#### **Recommendations (5)**

An over-arching assessment framework is required that takes staff through the various steps involved, including conceptualisation of the hydrological systems, evaluating objectives, data collection, data analysis, modelling and final assessment of impacts. The framework should adopt a risk-based approach that allows for uncertainty and includes the likelihood of the impact.

### **6.6 Restoration and Mitigation**

During the past 100 years many areas of wetland have been lost or degraded in the UK and there are numerous schemes to restore wetlands, create new ones and to mitigate negative impacts. The UK Biodiversity Action Plan for example, gives a target of 1,200 hectares of reedbed wetlands to be restored by 2010.

In many cases restoration would appear to be simply a matter of reversing the cause of the impact. For peat wetland sites on Exmoor, whose hydrology had been impacted by drainage ditches, some ditches had been blocked as a restoration measure. Dip wells have been installed and flows measured to test the effectiveness. It was uncertain as to whether the experimental design was correct (for example is a control site needed) and how long a data set is required to be representative. The three-year dataset collected was considered insufficient. The plant communities appeared to be changing very slowly, so it would take a long time to gather definitive results. The lag between water level change and vegetation change was noted.

Wetland conservation may also be achieved through mitigation of impacts rather than addressing the root cause. For example on Pevensy Levels, Sussex, it has been suggested that reduced water levels in ditches, which has resulted from upstream abstraction could be mitigated by operation of sluices. However, such solutions are not always available and they often raise issues of sustainability. The health of Great Cressingham Fen, which is impacted by abstraction for public water supply abstraction and spray irrigation for agriculture, relies on flow as well as level, so the appropriate hydrological regime could not be obtained by use of penning boards to maintain water levels. The water supply for the Fen needs to be high in calcite and of low nutrient status.

To some extent wetland restoration can bring very positive benefits for water management in a catchment. The potential benefits of restoring floodplains in the River Cherwell, Oxfordshire, in terms of reducing flood risk in towns inundated during the Easter 1998 floods was demonstrated in the Wise Use of Floodplains project, in which the Agency was involved (Acreman *et al*, 2003). Nevertheless, wetland restoration does

not always have positive impacts. On Brading Marshes, Isle of Wight for example, a 200 ha SPA, cSAC, Ramsar site containing saline lagoons and grazing marshes has been created by the installation of flood defences. RSPB had applied to raise the level of the sluice at the seaward end of the marshes to raise water levels and achieve favourable status. It was estimated that this would result in the loss of 10,000 m<sup>3</sup> of flood storage. Although this was equivalent to only 1% of the 100 year flood volume, it may increase flood risk in properties surrounding the wetland. This presents an awkward dilemma for the Agency, since under the Environment Act (1995), it is required to protect or enhance the environment. However, it must respond equitably to all applications and it is likely that, for example, a proposal for residential or commercial property development that would reduce flood storage would not be supported.

A further problem with wetland restoration and creation is that wetlands typically have higher evaporation rates than many other land cover types. Where wetlands are being created they represent a new consumptive use of water resources and are competing with other demands including public supply and irrigation. This is a particular problem in catchments with very scarce resources, such as the Eastern Yar, on the Isle of Wight. At Alverstone Marshes also on the Isle of Wight, a 0.5 km reach of river, running through the wetland, was to be re-instated. This raised concern that rehabilitating the wetlands would increase evaporation and reduce water availability in an already over-abstracted catchment. Mindful of the need to carefully assess water resource availability for wetland creation, the Agency has been involved in several evaluation studies at a national and regional scale, e.g. the Anglian Region (Environment Agency, 2001; Souch *et al*, 2000) which indicate that to restore 2500 ha of reedbed requires 45 MI/d and to restore 6000 ha of coastal and floodplain grazing marsh needs 92.9 MI/d. Water requirements have also been calculated for specific wetland projects, such as for the proposed Great Fen in Cambridgeshire (Manchester *et al*, 2003). Where wetlands are being restored, there is an argument that high evaporation from wetlands is simply a natural feature of the catchment. Indeed, the Agency national and regional Water Resources Strategies (2001) recognised wetlands as a legitimate water user. However, water resource evaluation, allocation and licensing may have been undertaken at a time when the wetlands were not present.

Even where water quantity is not an issue for restoration, its quality may have changed so that it is no longer suitable to support a wetland. At Oak Mere in Cheshire, returning the groundwater table to its former high level would not necessarily be good for the wetland because the aquifer's high nitrate load may degrade the current low nutrient wetland status.

#### **Recommendations (6)**

Guidance should be developed to determine under what circumstances wetland restoration is appropriate, with particular reference to conflicting priorities between enhancing and protecting the environment and safe-guarding the water needs of abstractors and flood protection.

## 6.7 Partnerships, Project Management and Funding

Impact assessment of wetlands requires an integrated approach, both technically and institutionally. Studies of wetlands require a multi-disciplinary approach that brings together a range of technical specialists including hydrologists, soil scientists, ecologists and hydrogeologists. Although one person, often the hydrologist, will take the lead, it is vital that other expertise is consulted at an early stage. Expertise may lie within the Agency in the same or other functions, such as Flood Defence, Water Quality or Fisheries, within a partner organisation, such as English Nature, or may need to be contracted from a university, research laboratory or consultancy. Indeed for many impact assessments led by the Agency, English Nature or Countryside Council for Wales has provided the ecological input rather than Agency staff. It has been recognised that combined site visits by all disciplines involved are an important part of any study. The level of expertise required often depends on the severity of the impact and the implications. Whilst a lone hydrologist may be content to undertake an assessment where there appears to be little impact on a non-contentious site, specialist support will be needed where the site is high profile, the situation is complex and the impacts may result from a variety of different interacting circumstances.

Institutional linkages are as vital as technical cooperation. Partnerships need to be established between the Agency and water companies, English Nature, local authorities and key NGOs, such as the RSPB, where they are land owner or have a vested interest. Partnerships should be formed at the beginning of the study so that each party takes ownership of the process, buys-in to the method followed and accepts more readily the results produced. Partnerships provide a wide and sound skills base, help build consensus and stimulate action by others. This follows general guidance already available within the Agency, such as that for appropriate assessments on Habitats Directive sites.

To undertake effective impact assessments, the Agency also needs good project managers with both technical and coordination skills, as well as sufficient time to manage the project. Good inter-personal skills are required to communicate information both internally within the Agency and externally. This should include the ability to present clear and concise information on issues and results for non-technical partners. For large projects it may be appropriate to contract specialist consultants to manage the study and to organise and run workshops. A key activity is to manage the expectations of the different partners.

Undertaking impact assessments can be expensive. Studies of the Kennet and Lambourn floodplain, that provide habitat for Desmoulin whorl snails, included substantial monitoring and modelling and is likely to cost £1.4 million over 4 years. Clearly it is not possible to provide this level of funding for many projects and many staff are having to undertake assessments on very limited budgets. Partnerships may provide opportunities to raise funds, such as through the Asset Management Plan (AMP) process or through university research funding.

The impact assessment of the Derwent Ings (Yorkshire) provides an excellent example of both inter-disciplinary studies and stakeholder partnerships. The 1995/6 drought stimulated a partnership between English Nature, the Agency and Yorkshire Water to assess impacts on the site from abstraction, operation of a barrage and other sources. A

range of modelling was undertaken including hydrological (HYSIM), hydraulic (MIKE II) and phosphate (CATNAP) modelling. The project was managed by a contracted consultant. Technical workshops for partners and interest groups (30-40 people) have been a feature of the study. Funds came from both within the Agency (regional and national flood defence and water resources) and Yorkshire Water through AMP3.

### **Recommendations (7)**

Agency staff need to be made aware of guidance that has been prepared on working with external partners.

Simple non-technical literature should be developed for partners that describes Agency procedures for impact assessment and the issues faced to help manage expectations.

Guidance on project planning and management, specific to wetlands should be developed. Where appropriate Agency staff should attend a project management course. This needs to be linked to the development of competencies through personal development plans and performance objectives for individual staff.

## **6.8 Knowledge Management**

Through monitoring, data analysis and modelling, the Agency and other groups, including universities, research laboratories, consultants, NGOs and water companies have built up a vast knowledge of the wetlands of England and Wales. This information is expensive to collect and represents a national resource that not only serves any particular project, for which it may have been collected, but also provides the basis for understanding the functioning of wetlands and other ecosystems. Unfortunately sometimes this information is either irretrievably lost (e.g. deleted from computer files), not readily retrievable or staff simply do not know that it exists. For example, at Newbald Becksies, a spring-fed Chalk wet grassland, pumping test data from water supply boreholes could not be found, although these may have provided a good insight into the hydraulic conductivity of the aquifer. At Walmore Common, a wet grassland on the floodplain of the River Severn, reports of previous studies of how the wetland functioned hydrologically could not be found.

As with any large organisation, staff within the Agency eventually change posts, get promoted or leave. This can lead to a lack of institutional memory. Consequently, it is vital that a good quality assurance system and database structure is maintained to ensure that data and reports from projects and studies can be located. Often very useful pieces of information are recorded and stored on, for example, abstraction licence files which would not normally be consulted by staff outside the local area. There are also limited mechanisms for recording non-impacts.

In an ideal world all project results and data would be stored on a national database that is accessible and searchable by all staff. However, this would present a large overhead on staff to provide summaries of every activity on a national scale. A more realistic approach would be to undertake periodic reviews to update databases and guidance

documents with the latest experience, data and results. A reference database is provided at part of this study (Chapter 7).

A key element of knowledge management is interaction between staff with common interests and responsibilities. Mechanisms need to be put in place to facilitate the exchange of information and best practice. Communication between Agency staff working on wetlands should not be restricted to specific projects. Regular meetings of staff, such as the Kent Wetlands Group, provide opportunities to discuss general issues, share experience and best practice.

Many Agency staff highlighted knowledge management as a key issue. However, it is recognised that there is a current initiative within the Agency to address this. As a result the subject is not dealt with extensively in this report.

### **Recommendations (8)**

The potential for establishing wetland groups on a local level should be considered for sharing experience and best practice.

A national point of contact for wetland issues and information should be established.

The feasibility of a national database to hold information on wetlands should be examined.

## 7. DATABASE

Part of the project was concerned with developing a database of reports and published scientific papers related to the impact assessment of wetlands. The Centre for Ecology and Hydrology at Wallingford has established a small library of literature in this area over the past 5 years. These include internal Agency and CEH reports. This library was used as the basis for a new database. References in commonly available journals and books were added, though these are not necessarily available directly from CEH.

The database is in Microsoft Access format and can be found on a CD ROM in the back of this document. It comprises two parts:

- 1) References produced, including published, refereed papers, internal reports and chapters of books.
- 2) Wetland research projects, mainly undertaken by CEH, for which a body of data has been collected on a wetland, but is not necessarily connected to a published paper.

Part 1) of the database contains 1487 references, 32% of which are based on studies within the UK, 591 (40%) are references on general Wetland topics, 230 references (15%) are within the subject area of Water Resources and 159 (10%) are on Environmental flows. The database includes information on the location of the reference, author, date of publication/production, title, which book, report or journal it appears in, abstract, country where study was based and key words. Searching the database can be done via a word search of the title, abstract of key words, or through searching for the author's name or country of research.

Part 2) of the database contains 164 projects covering wetland research projects mainly carried-out by CEH. Seventy-seven (approx. 50%) of the projects have been conducted by researchers based at CEH Wallingford. Information on the title of the project, or the wetland on which research was carried out, is listed, along with the country or region in which it was located, the CEH/NERC project code, project leader, and period of time over which data was collected.

The plan is that the database will not be a static list of references, but will grow as more relevant published or unpublished material is located. Thus updated copies of the database will need to be produced in future. Where possible CEH will obtain hard or electronic copies of the documents particularly from the more obscure sources that the Environment Agency may have trouble locating easily.

In the first instance, Agency staff should seek copies of references through normal channels such as inter-library loan, and the British Lending Library. Where papers or reports cannot be traced, a request should be made to the library of the Centre for Ecology and Hydrology at Wallingford. The database indicates if CEH holds a copy.

## **8. RESEARCH NEEDS**

A workshop was held on 2-3 February 2002 for CEH staff to identify basic and applied research needs. This was part an exercise to develop the Wetlands Research Coordination Group, a multi-disciplinary pool of experts within CEH laboratories across the UK. The scope of the workshop was not exhaustive, but focused principally on the areas of scientific expertise and experience of CEH staff. The following areas were identified as highest priority for research. Several of these overlap with issues highlighted by Agency staff, and are included within the recommendations of this project.

### **Basic science issues**

#### Water/plant relations

- Relationships between soil moisture and soil water level - linking plants, water level and micro-topography.
- Water table regimes v plant species/communities. Duration, timing and extremes.
- Consequences for ditch fauna of different water level regimes.
- Trees in wetlands – plant physiology

#### Water quality/nutrients

- Water quality as a controller of wetland community assemblages.
- Water quality functioning of wetlands. Process and control. Nutrients and contaminants.

#### Water and gas fluxes

- Water/microbe interaction in wetlands and implications for carbon cycling (methane and CO<sub>2</sub> fluxes)
- Evaporation processes in grasses, reeds and wetland trees.

#### Broad scale analysis

- Remote sensing techniques for wetland modelling
- Integrated landscape and catchment management tools for farming, fauna and flora

#### Water and viruses

- Impact of wetland wetness on cattle and wildlife viruses

#### Surface/groundwater interactions and wetlands

- Hydraulic connectivity between aquifers and wetlands
- Conductivity of low permeability layers between aquifers and wetlands
- Spatial heterogeneity in conductivity

## **Applied science issues**

### Restoration/creation

- Methods and tools for restoring cut-over peatlands.
- Approaches to wetland creation to supply irrigation needs

### Surface/groundwater interactions and wetlands

- Conceptualising connectivity between aquifers and wetlands
- Modelling groundwater fed wetlands
- Handling spatial heterogeneity in conductivity in impact assessment

### Decision-support

- Conservation choices/conflicts - best options for wetland management
- Managing greenhouse gas emission from wetlands for water management, greenhouse gas
- Assessment of different land/water management options
- Decision support systems for integrating water, agriculture and biodiversity

### Water/plant relations

- Managing wetlands for reed production
- Potential for biofuels – willow coppice
- Evaporation rates for different wetland species

### Birds

- Managing wetlands for specific bird populations

### Functional analysis

- Assessment of wetland function and vulnerability to change

### Water quality improvement

- Interception and remediation of road and urban runoff
- Buffering nitrate in groundwater
- Defining wetland load thresholds

### Greenhouse gas emission

- Effect of management on processes (greenhouse gas emissions) – develop predictive ability
- Modelling climate feedback from large scale wetlands
- Land use change (draining or creating wetlands) and greenhouse gases
- Greenhouse gas budget on regional and landscape scale

### Water Framework Directive

- Role of wetland functions in achieving ‘good ecological status’
- Protecting wetlands from abstraction and gravel extraction

### Catchment management

- Linking water level management plans with flood catchment management plans
- Including wetlands within Catchment Abstraction Management Strategies



## Viruses

- Human cattle virus management

## **9. RECOMMENDATIONS**

The impact assessment of wetlands represents a broad area of interest for the Agency and a wide range of recommendations came from discussions with staff. Some recommendations were felt to be important, but beyond the scope of the water resources function. These might be considered by other functions of the Agency (implementation Class 3). Recommendations relating to water resources are sub-divided into those that will be taken forward in the second phase of this project (Class 1), and those that will be considered in future work (Class 2).

### **9.1 Implementation Class 1 (for Phase 2 of this project)**

A review of current approaches to wetland classification should be undertaken, particularly past work by Lloyd and Tellam and current work by Wheeler and Shaw, and, if appropriate, a system that captures our conceptual understanding should be recommended. If no such classification exists, a new one should be developed.

Current knowledge on evaporation rates from different wetland vegetation communities should be reviewed and where possible, look-up tables of default values should be reviewed. Guidance is needed on how to estimate evaporation from different methods.

A review should be undertaken of the methods and tools available to carry out assessment of the anthropogenic impacts on wetlands, highlighting best practice in the Agency as a basis for a consistent approach to assessment. This should include guidance on the skills and resources needed to use each method, their data needs and the improvement in accuracy that can be obtained by collecting extra data, such as long time series and spatial heterogeneity. The tools reviewed should be incorporated into a hierarchy for assessment, starting with simple analytical methods and ranging up to more complex numerical models.

### **9.2 Implementation Class 2 (for consideration for future work)**

An over-arching assessment framework is required that takes staff through the various steps involved, including conceptualisation of the hydrological systems, evaluating objectives, data collection, data analysis, modelling and final assessment of impacts. The framework should adopt a risk-based approach that allows for uncertainty and includes the likelihood of the impact.

Guidance and training should be produced for Agency staff on how to develop conceptual understanding of wetlands and their hydrological environment. This should include sections on the following:

- techniques for identifying the contribution of various water sources, such as geophysical surveys;
- complex geology, where there are many substrate layers (with each having its own water table level), or where layers are variable in thickness or hydraulic conductivity;
- perched water tables, or where springs upslope feed valley bottom wetlands;
- relationship between floodplains and low river flows;
- natural hydrological variability.

A consolidated guide to designing and operating wetland monitoring should be produced for Agency staff. This should include best operational practice within the Agency, including simple techniques. It should include a route map (e.g. see flowchart in Lloyd and Tellam 1995) for planning site investigation. Particular focus should be on what data to collect (eg. groundwater heads from different layers) and on the frequency of data collection (eg. hourly, daily or weekly). Outputs should include a leaflet for site owners on what standard data should be collected where possible at all sites.

A scoping study should be initiated to consider the feasibility and requirements for producing look-up values for leakage/hydraulic conductivity at the wetland/aquifer interface. This should include details of what is known and what needs to be researched.

The feasibility of producing a desktop tool for wetlands impact assessment to plug the gap in the hierarchy between simple spreadsheet tools, and fully distributed numerical models should be investigated. This should be considered after completion of the proof of concept of the OO Code.

Guidance on project planning and management, specific to wetlands should be developed. Where appropriate, Agency staff should attend a project management course. This needs to be linked to the development of competencies through personal development plans and performance objectives for individual staff.

### **9.3 Implementation Class 3 (for other functions of the Agency to consider)**

Operational staff would like the Agency to provide guidance on a range of issues related to setting and achieving objectives for various drivers. These include:

- Implications of the “do nothing” option and how this varies between different situations;
- How to resolve conflicting interests (e.g. people v wildlife);
- How to set and prioritise objectives for a site especially when different drivers appear to conflict.

In many cases these will involve dialogue with interested parties.

Work on water regime requirements of wetland plant communities should be extended to other inland vegetation types e.g. raised bogs, wet heath, wet woodland and to coastal wetlands. This is already being considered.

Guidance should be developed to determine under what circumstances wetland restoration is appropriate, with particular reference to conflicting priorities between enhancing and protecting the environment and safe-guarding the water needs of abstractors and flood protection.

Agency staff need to be made aware of guidance that has been prepared on working with external partners.

Simple non-technical literature should be developed for partners that describes Agency procedures for impact assessment and the issues faced to help manage expectations.

The potential for establishing wetland groups on a local level should be considered for sharing experience and best practice.

A national point of contact for wetland issues and information should be established.

The feasibility of a national database to hold information on wetlands should be examined.

## **10. SCOPE OF WORK FOR PHASE 2**

The original project specification included a preliminary scope of work for Phase 2. However, it was recognised that this would need to be reviewed, in the light of priority business needs for water resources as identified in Phase 1. The revised programme of work for Phase 2 is outlined below.

### **Objectives**

- To improve our conceptual understanding of wetland systems and how they interact with surrounding surface and groundwater systems.
- To review the methods and tools available to carry out assessment of the anthropogenic impacts on wetlands.

### **Programme of work**

Task 1 - Identify or develop a suitable conceptual model based classification of wetland habitats for water resources. This should be based on the relative setting of the wetland with respect to the hydrological and hydrogeological system. The end result will be a classification of different conceptual wetland settings to cover the main England and Wales situations.

Task 2 - Write guidance on how to carry out a quantitative water balance for a particular site. The need for guidance on how to develop conceptual understanding of wetlands has been highlighted as a major issue. A quantitative water balance can be used to test understanding, and is an essential prerequisite to any impact assessment.

Task 3 - Review current knowledge of evaporation rates from different wetland vegetation communities. If possible, look-up tables of default values should be produced, together with guidance on how to estimate evaporation from different methods.

Task 4 - Review the tools available to test our conceptual models and carry out impact assessments at wetlands. The tools reviewed should be fitted into a tiered hierarchy according to their complexity, data needs, costs and expertise, with basic, intermediate and detailed levels of model. The output should include a functionality matrix relating the models/tools to wetland processes, superimposing the tiers.

Task 5 – Produce a scientific paper for a peer-reviewed journal on impact assessment at wetlands.

## REFERENCES

- Acreman, M.C., José, P. (2000) Wetlands. In: Acreman, M.C. (ed) *The hydrology of the UK; a study of change*. Routledge, London.
- Acreman, M.C., Booker, D.J., Riddington, R. 2003 Hydrological impacts of floodplain restoration: a case study of the river Cherwell, UK. *Hydrology and Earth System Sciences*. 7,1, 75-86
- Acreman, M.C., Harding, R.J., Lloyd, C.R., McNeil, D.D. 2003 Evaporation characteristics of wetlands; experience from a wet grassland and a reedbed using eddy correlation measurements. *Hydrology and Earth System Science*, 7, 1, 11-22
- Al-Khudhairi, D.H.A., Leemhuis, C., Hoffman, V., Calaon, R., Shepherd, I.M., Thompson, J.R., Gavin, H., Gasca-Tucker, D.L. 2001 Monitoring wetland ditch water levels in the North Kent Marshes using Landsat TM imagery and ground-based measurements. *Hydrological Sciences Journal*, 46, 4, 585-597.
- Al-Khudhairi, D.H.A., Thompson, J.R. Gavin, H. and Hamm, N.A.S. 1999. Hydrological modelling of a drained grazing marsh under agricultural land use and the simulation of restoration management scenarios. *Hydrol Sci. J.* 44, 6, 943-971.
- Armstrong, A.C., Rycroft, D.W. and Welch, D.J. 1980. Modelling water table response to climatic inputs - its use in evaluating drainage designs in Britain. *J. Agric. Eng. Res.* 25, 311-323.
- Armstrong, A.C. 1993. Modelling the response of in-field water tables to ditch levels imposed for ecological aims: a theoretical analysis. *Agriculture, Ecosystems and Environment*, 43, p345-351.
- Armstrong, A. and Rose, S. 1999. Ditch water levels managed for environmental aims: effect on soil water regimes. *Hyd. and Earth Syst Sc.*, 3(3), 385-394.
- Belmans, C., Wesseling, J.G. and Feddes, R. 1983. Simulation of the water balance of a cropped soil: SWATRE. *J. Hydrol.*, 63, p271
- Betts, S., Papaioannou, A. (2003) *Guidance for assessing the hydrological requirements for Habitats Directive interest features*. Report to Environment Agency.
- Davis, R., Cunningham, R., Avis, C. 2003 *The Role of Wetlands in the Water Framework Directive*. UK Technical Advisory Group
- Environment Agency (in press) A guide to monitoring water levels and flows at wetland sites. Environment Agency, Bristol
- Environment Agency (2001) Water resources for the future. A strategy for Anglian region. Environment Agency, Bristol

ENTEC 2003 Environment Agency Anglian Region Strategy for Groundwater Investigations and modelling – Guidance for the Appropriate Assessment of Impacts from Licensed Abstractions on the Hydrological Regime of Groundwater Fed wetlands. Technical Note. September 2003

Faulkner, D., Maudsley, J., Brassington, F., Boak, R., Fletcher, S., Johnson, D., Evers, S. (in press) *Risk-based decision-making for water resources licensing. Phase 2: Guidance on conducting a hydro-geological impact appraisal.* R&D Technical Report W6-071/TR2.

Fermor, P., Hedges, P., Gilbert, J., Gowing, D. 2001 Reedbed evapotranspiration rates in England, *Hydrological Processes*, 15, 621-631

Gavin, H. 2003 Scoping study on guidance for the monitoring of wetlands under the requirements of the Water Framework Directive. Report to Environment Agency by WS Atkins.

Gilvear, D.J., Sadler, P.J.K., Tellam, J.H. and Lloyd, J.W. 1997. Surface water processes and groundwater flow within a hydrologically complex floodplain wetland, Norfolk Broads, UK. *Hydrol. and Earth Syst. Sci.*, 1, 115-135.

Gilman, M.C. 1994 *Hydrology and wetland conservation.* Wiley, Chichester and Institute of Hydrology, Wallingford.

Humphreys, I, Kellett, K. 2003 *A biological and chemical classification of the north Kent springs – results of second survey.* Environment Agency, Kent.

Lloyd J, Tellam J, Rukin N, Lerner D 1993 Wetland Vulnerability in East Anglia: A Possible Conceptual Framework and Generalized Approach. *Journal of Environmental Management*, 9, 37, 87-102.

Marks, K. Bates, P., 2000. Integration of high-resolution topographic data with floodplain flow models. *Hydro. Proc.*, 14, 2109-2122.

Manchester, S.J., McCartney, M.P., Mountford, J.O., Wadsworth, R.J. 2003 *Wildlife Habitats and their requirements within the Great Fen project.* Final Report to the Great Fen Project Steering Group. Centre for Ecology and Hydrology.

McCartney, M., de la Hera, A., Acreman, M.C. & Mountford, M.O. 2000. *An investigation of the water budget of Wicken Fen.* Report to National Trust. CEH Wallingford

Mook, W.G. 2001 *Environmental isotopes in the hydrological cycle principles and applications.* UNESCO International Hydrological Programme.

Simons, E., Clarke, S.J. 2002 *A review of water resource assessment methods and licensing practices in fenland areas.* Report by ENTEC to Environment Agency National Groundwater and Contaminated Land Centre - NC/01/63

Skaggs, R.W. 1980. A water management model for artificially drained soils. North Carolina Agric. Res. Service, State University Tech Bull, 267.

Souch, C., Gilbert, J., Gowing, D., Hess, T., Fiorini, E. 2000 Anglian Region joint study on water resources availability for wetland creation. Report to Environment Agency, RSPB and English Nature. Cranfield University.

Theis, C.V. 1935 The lowering of the piezometric surface and the rate of discharge of a well using groundwater storage. *Transactions American Geophysical Union*. 16, 519-524.

Wheeler, B.D., Shaw, S.C. 2000 A wetland framework for impact assessment at statutory sites in Eastern England. Environment Agency R&D Report W6-068/TR1.

Youngs, E.G., Leeds-Harrison, P.B. and Chapman, J.M. 1989. Modelling water movement in flat low-lying lands. *Hydrol. Proc.*, **3**, 301-315.

Youngs, E.G., Chapman, J.M., Leeds-Harrison, P.B. and Spoor, G. 1991. The application of a soil physics model to the management of soil water conditions in wildlife habitats. In: *Hydrological Basis of Ecologically Sound Management of Soil and Groundwater*. Proc. of Vienna Symposium, Aug 1991. IAHS Publ. no 202, 91-100.



## Annex 1 ABBREVIATIONS

ALF	Alleviation of Low Flows
AMP	Asset Management Plan
AQUA 3D	a 3d groundwater model
Bern Convention	Convention on the Conservation of European Wildlife and Natural Habitats
CAMS	Catchment Abstraction Management Strategies
CATNAP	a phosphate model
CEH	Centre for Ecology and Hydrology
CFMP	Catchment Flood Management Plans
CROW	Countryside and Rights of Way (Act)
DEFRA	Department for Environment, Food and Rural Affairs
DITCH	a soil moisture model
DRAINMOD	a soil moisture model
EA	Environment Agency
EC	European Commission
ERT	electrical resistivity tomography
EU	European Union
FDRAIN	Soil moisture model
GPR	ground penetrating radar
HYSIM	a hydrological model
IGARF	Impact of Groundwater Abstractions on River Flows
MIKE II	a hydraulic model
MODFLOW	a 3d groundwater model
LIDAR	Laser Induced Direction and Range (LIDAR).
MAFF	Ministry of Agriculture, Fisheries and Food
MORECS	Meteorological Office Rainfall Evaporation Calculation System
NGCLC	National Groundwater and Contaminated Land Centre
NVC	National Vegetation Classification
OfWat	Office of Water
PINHEAD	a ditch water level model for wetlands
RAM	Resource Assessment and Management (Framework)
Ramsar	International Convention on Wetlands
RSA	Restoring Sustainable Abstractions
SAC	Special Area of Conservation
SAR	Synthetic Aperture Radar
SHYLOC	System for Hydrology Land Observation for Model Calibration
SPA	Special Protection Area (for birds)
SSSI	Site of Special Scientific Interest
SWATRE	a soil moisture model
WETMECS	WETland water supply MEChanism types

## Annex 2 RETURNED QUESTIONNAIRES

### Wetland Impact Assessments

1. Wetland Name		Alverstone SSSI
2. Wetland type		3. Water source
Fen/reed bed Wet Grassland <input checked="" type="checkbox"/> Bog/ mire (upland/lowland) Wet heath Wet woodland Other (please specify)		Surface-water fed Groundwater fed * <input checked="" type="checkbox"/> Combined surface-water/ groundwater fed  * Intermittent surface water feeding from over-topping & sluice operation.
4. What question were you trying to answer? ie. the reason for carrying out the assessment, type of impact etc.		
Impact of river restoration works on flood risk and water resources.		
5. What was your conceptual understanding of the wetland system and how certain were you? Did you consider hydrology, hydrogeology, ecology?		
It was assumed the bog is in hydrological contact with groundwater as well as fed by rainfall. Available data confirmed this and that reversal of previous deep drainage would raise water levels on the bog.		
6. Who did the work (Agency/consultants etc)? How many people were involved and what were their backgrounds (hydrology, hydrogeology, ecology, water quality etc).		
Atkins Water hydrologist		
7. Roughly how long did the study take?		
<input checked="" type="checkbox"/> A few days <input type="checkbox"/> Months <input type="checkbox"/> Years		
8. What was the cost?		
<input checked="" type="checkbox"/> <£10k <input type="checkbox"/> £10-50k <input type="checkbox"/> >£50k		
9. Did the assessment follow a standard procedure?		
Yes, please provide details		
No		

<p><b>10. Please provide a brief overview of what was done in carrying out the assessment.</b></p> <p>Data were used to examine relationship between water levels and the proposed water course and groundwater levels. Ultimately, the assessment was to show that restoration would not significantly consume water or exacerbate flood risk.</p>
<p><b>11. Was the assessment purely desk based, or did it involve site investigation?</b></p> <p>1 day site visit; 1 day levelling; 4-5 days desk study</p>
<p><b>12. What data were used, were there enough, were the data representative?</b></p> <p>The area was levelled and profiles of the old and new water courses were taken. Groundwater was measured. LIDAR data were also used.</p>
<p><b>13. What, if any, specific tools or models were used in the assessment? How useful were they?</b></p> <p>Levelling tools, LIDAR, ARCVIEW.</p>
<p><b>14. Was the study successful? What problems arose? How confident were you in the results? .</b></p> <p>As there were no records of winter and summer flow at Knighton, it was not ultimately possible to calculate to what extent this restoration would consume water.</p>
<p><b>15. What gaps or needs did you identify? What would help you overcome the problems identified in Qu 14? Score 1-5 (1 =most important, 5 = least important)</b></p> <p>I strongly feel that the issues we tackled should have been tackled at National Policy Level.</p> <p>Does river restoration constitute a consumptive use of water and, if so, can it be prevented (by Agency Water Resources) in an over-abstracted catchment despite the necessity to improve the SSSI?</p>

Karen McHugh

## Wetland Impact Assessments

<b>1. Wetland Name</b> Ant Broad and Marshes SSSI (component of Broads cSAC, Broadland SPA and Broadland Ramsar site).	
<b>2. Wetland type</b>  Fen/reed bed <input checked="" type="checkbox"/> Wet Grassland Bog/ mire (upland/lowland) Wet heath <input checked="" type="checkbox"/> Wet woodland <input checked="" type="checkbox"/> Other (please specify) Broad	<b>3. Water source</b>  Surface-water fed Groundwater fed Maybe <input checked="" type="checkbox"/> Combined surface-water/ groundwater fed  Well points 20 x 10 m x 50 mm 150 m west of designated site.
<b>4. What question were you trying to answer?</b> ie. the reason for carrying out the assessment, type of impact etc.  Assessing the impact of operational abstraction on the designated features of the European site, with a view to securing an abstraction licence.	
<b>5. What was your conceptual understanding of the wetland system and how certain were you?</b> Did you consider hydrology, hydrogeology, ecology?  Assessment in the form of a pumping test was designed to determine the impact of operational abstraction on the designated site. Limited understanding of the hydrology/hydro-geology and their interactions with the site. Project set out to enhance hydro-geological understanding with a view to determining the impacts.	
<b>6. Who did the work (Agency/consultants etc)?</b> How many people were involved and what were their backgrounds (hydrology, hydrogeology, ecology, water quality etc).  External consultant (hydrologist). Funded by applicant. Technical data collection (sub-contracted). Internal auditing EA Hydrogeologist and Regulatory Officer.	
<b>7. Roughly how long did the study take?</b> A few days <input checked="" type="checkbox"/> Months <input type="checkbox"/> Years <input type="checkbox"/>	
<b>8. What was the cost?</b> <£10k <input checked="" type="checkbox"/> £10-50k <input type="checkbox"/> >£50k <input type="checkbox"/>	
<b>9. Did the assessment follow a standard procedure?</b> Yes, please provide details <input checked="" type="checkbox"/> No	

**10. Please provide a brief overview of what was done in carrying out the assessment.**

Desk assessment, previous pumping test, environmental reports, new and existing piezometers monitored with data loggers during the test. Rainfall, barometric pressure, broad level, abstraction, sw drain data collected. Analysed to show presence of confining layer isolating peat water table from aquifer.

**11. Was the assessment purely desk based, or did it involve site investigation?**

No, desk and on-going monitoring - April -September 2002  
Several site visits, consultant, EA, data collection.

**12. What data were used, were there enough, were the data representative?**

Very limited data available before the test. Use of data loggers vital for identification of evaporation and tidal effects. Piezometers at different levels (deep piezos in water table above drain level throughout vertical gradients (and changes) assessed. Levelling undertaken.

**13. What, if any, specific tools or models were used in the assessment? How useful were they?**

Consultant used for modelling - finite distributed model  
Not vital to decision-making

**14. Was the study successful? What problems arose? How confident were you in the results? .**

Yes, licence issued 04/03. Highlighted importance of daily rate.  
Endorsed by English Nature as good example. Further work related to RoC.  
Abstraction not affecting shallow water table in wetland. Evaporation largest impact.  
Potential for upward groundwater movement retained.

**15. What gaps or needs did you identify? What would help you overcome the problems identified in Qu 14? Score 1-5 (1 =most important, 5 = least important)**

Need for a data logger on peat piezometers.  
Abstracted water from where ? to where ?  
Water quality questions.

Mark Reid

## Wetland Impact Assessments

<b>1. Wetland Name</b>		Arun Valley SPA, Ramsar, component SSSI's
<b>2. Wetland type</b>		<b>3. Water source</b>
Fen/reed bed <input checked="" type="checkbox"/> Wet Grassland Bog/ mire (upland/lowland) Wet heath Wet woodland Other (please specify)		Surface-water fed <input checked="" type="checkbox"/> Groundwater fed * Combined surface-water/ groundwater fed  * Intermittent surface water feeding from over-topping & sluice operation.
<b>4. What question were you trying to answer? ie. the reason for carrying out the assessment, type of impact etc.</b>		
<p>Phase 1: to identify the significance of existing Southern Water groundwater abstraction at Hardham on water levels within, and water inputs into the designated Arun Valley wetland system.</p> <p>Phase 2 (proposed): to appropriately assess the impact of the groundwater abstraction on the designated interest features of the site (to satisfy the requirements of the Habitats Regulations 1994).</p>		
<b>5. What was your conceptual understanding of the wetland system and how certain were you? Did you consider hydrology, hydrogeology, ecology?</b>		
<p>The site was understood to be predominantly groundwater fed from the Folkstone Beds aquifer, with minimal surface water input via flood bank overtopping and sluice gate operation. Greater understanding of the hydrogeology was necessary to demonstrate actual 'mechanism for effect' and quantify the extent to which water levels within the site are vulnerable to groundwater abstraction.</p> <p>Ecology of the site is understood to be in favourable condition; assessment of water level requirements and ecological impacts were outside the scope of the Phase 1 assessment, although need to be considered at the appropriate assessment stage.</p>		
<b>6. Who did the work (Agency/consultants etc)? How many people were involved and what were their backgrounds (hydrology, hydrogeology, ecology, water quality etc).</b>		
Entec consultants. Subsequent consultation/ verification with EA and English Nature.		
<b>7. Roughly how long did the study take?</b>		
A few days <input checked="" type="checkbox"/> Months    Years		

<p><b>8. What was the cost?</b></p> <p>&lt;£10k    <input checked="" type="checkbox"/> £10-50k    &gt;£50k</p>
<p><b>9. Did the assessment follow a standard procedure?</b></p> <p>Yes, please provide details</p> <p><input checked="" type="checkbox"/> No</p>
<p><b>10. Please provide a brief overview of what was done in carrying out the assessment.</b></p> <p>Phase 1:  Desk-top study of regional geology and hydrogeology;  site conceptual models of the three component SSSI's drawing on information regarding geology, groundwater level behaviour, hydrology, and water inputs and outputs within the sites, to assess the potential vulnerability to groundwater abstraction;  preliminary estimation of natural water budgets, including long-term average components of surface water, rainfall and groundwater inflows, and evaporative and surface water outflows.</p>
<p><b>11. Was the assessment purely desk based, or did it involve site investigation?</b></p> <p>Mainly desk based.</p>
<p><b>12. What data were used, were there enough, were the data representative?</b></p> <p>Meteorology, hydrology, hydrogeology and geology datasets.</p> <p>No surface water flows were measured at any of the three (SSSI) sites, therefore it was not possible to verify the water budgets by comparison with observed flows.</p>
<p><b>13. What, if any, specific tools or models were used in the assessment? How useful were they?</b></p> <p>Penman-Grindley soil moisture accounting method, used to estimate recharge of the regional aquifer.  Preliminary water budgets.</p>
<p><b>14. Was the study successful? What problems arose? How confident were you in the results?</b></p> <p>The study was successful in demonstrating a mechanism for effect between the groundwater abstraction, and Pulborough and Waltham SSSI's; insufficient evidence to conclude on Amberley Wildbrooks but geographical structure probably protects this site.</p>

**15. What gaps or needs did you identify? What would help you overcome the problems identified in Qu 14? Score 1-5 (1 =most important, 5 = least important)**

Lack of hydrological data (levels, flows etc) to maximise the reliability of the modelling on which the assessment has primarily been based.

Jo Simmons  
23/6/03



## Wetland Impact Assessments

<b>1. Wetland Name</b> Brading Marshes	
<b>2. Wetland type</b> <input checked="" type="checkbox"/> Fen/reed bed <input checked="" type="checkbox"/> Wet Grassland Bog/ mire (upland/lowland) Wet heath Wet woodland Other (please specify)	<b>3. Water source</b> <input checked="" type="checkbox"/> Surface-water fed Groundwater fed Maybe Combined surface-water/ groundwater fed  The site is part of the reclaimed estuary of the Eastern Yar (1870s). It is protected by a sea wall. The river Yar runs through the site & a tide gate in the sea wall.
<b>4. What question were you trying to answer? ie. the reason for carrying out the assessment, type of impact etc.</b>  What is the impact of recreating the wetland for biodiversity purposes on (1) flood risk (2) water resources. (1) raising water levels reduced floodplain storage which increases flood risk (2) wetting-up land increases evaporation, which places a demand on water resources.	
<b>5. What was your conceptual understanding of the wetland system and how certain were you? Did you consider hydrology, hydrogeology, ecology?</b>  The site is the sump of the river system behind a sea wall. It is below mean sea level. The river running through the site & the sea wall is tide-locked on each tidal cycle. The penning level (of the river behind the tide gates) directly affects groundwater levels in the site. The river floods the site during the wet season.	
<b>6. Who did the work (Agency/consultants etc)? How many people were involved and what were their backgrounds (hydrology, hydrogeology, ecology, water quality etc).</b>  We propose to develop a fluvial and coastal management strategy (DEFRA needs). This will cover extreme events and dominant regimes. It will aim to answer (1) and (2) above in Question 4.	
<b>7. Roughly how long did the study take?</b> A few days      Months <input checked="" type="checkbox"/> Years      Estimated time to develop strategy 1.5 years	
<b>8. What was the cost?</b> <£10k      £10-50k <input checked="" type="checkbox"/> >£50k      Estimated costs of strategy £250,000	

<p><b>9. Did the assessment follow a standard procedure?</b></p>	<p>Yes, please provide details</p>	<p>N/A</p>
<p>No</p>		
<p><b>10. Please provide a brief overview of what was done in carrying out the assessment.</b></p>		
<p>We will monitor fluvial and coastal processes gain an understanding of these processes, model them where appropriate. Then consider various management options.</p>		
<p><b>11. Was the assessment purely desk based, or did it involve site investigation?</b></p>		
<p>It will be both desk-based and site investigations.</p>		
<p><b>12. What data were used, were there enough, were the data representative?</b></p>		
<p>We will use historical "coarse" data to give an overview and trends. We will use new "finer" data to get/design details.</p>		
<p><b>13. What, if any, specific tools or models were used in the assessment? How useful were they?</b></p>		
<p>FEH, ISIS etc</p>		
<p><b>14. Was the study successful? What problems arose? How confident were you in the results? .</b></p>		
<p>Wait and see.</p>		
<p><b>15. What gaps or needs did you identify? What would help you overcome the problems identified in Qu 14? Score 1-5 (1 =most important, 5 = least important)</b></p>		
<p>We will do a post-project appraisal to identify gaps.</p>		

Tony Burch

## Wetland Impact Assessments

1. Wetland Name: Cridmore Bog SSSI, Isle of Wight	
2. Wetland type  Fen/reed bed <input checked="" type="checkbox"/> Wet Grassland <input checked="" type="checkbox"/> Bog/ mire (upland/lowland) <input checked="" type="checkbox"/> Wet heath  Wet woodland  Other (please specify)	3. Water source  Surface-water fed  Groundwater fed <input checked="" type="checkbox"/> Combined surface-water/ groundwater fed
4. What question were you trying to answer? ie. the reason for carrying out the assessment, type of impact etc.  <p>Surface water abstraction (reservoir dug into SSSI in early 1980s) perceived to be drying out bog and associated wet habitats. The reservoir was meant to be winter fill, but was in fact intercepting ground water and was filled under artesian pressure from below. Examination of site in 1996 suggested that damage to wetland was more likely to be resulting from deep drains through the wetland, draining down surface waters. The Agency ended up moving the abstraction license from the reservoir anyway, but also undertook works to plug up main drains to bring water levels back up in the Bog. This appears to have helped, but similar work is required over a much larger area of the wetland to secure the future of the SSSI. No formal EIA was ever done - this office is not resourced to undertake such EIA. However, the restoration works were the subject of consultation with EN, IoWCC ecology and archaeology, land owner, and Wildlife Trust. Some biological and hydrological survey / monitoring undertaken. My feeling is that the impact to the Bog is primarily the result of surface water drainage, although some ground water influence is also possible. More works are proposed over the next three years to raise water levels in other areas of the Bog.</p>	
5. What was your conceptual understanding of the wetland system and how certain were you? Did you consider hydrology, hydrogeology, ecology?  <p>Dip wells installed indicated very clearly a cone of depression towards drainage ditches with very good conductivity through open structured peat. Water level in the adjacent reservoir has always been higher than ground surface in the bog. Underlying lenses of clay in the greensand were apparent from intrusive investigation. pH in the reservoir was around 4.4, but closer to 6 or 7 at the surface in the Bog. My theory was primarily a surface fed, perched wetland with lateral movement of water from the steep valley sides and potentially some upward movement of water from the underlying greensand aquifer which was clearly under pressure. Discussions with a hydrologist on site broadly confirmed this.</p>	

6. Who did the work (Agency/consultants etc)? How many people were involved and what were their backgrounds (hydrology, hydrogeology, ecology, water quality etc).

I did by far the bulk of the work based on first hand observation over many site visits within the first year. Prior to that, no one from the Agency or English Nature had given the site enough thought to begin to understand the nature of the issues, e.g EN believing the abstraction from ground water was the problem, when this was likely to only be a small component. I am an ecologist, not a hydrologist, but my conceptual understanding was confirmed by a hydrologist from the Area Water Resources Team. Discussions with numerous other ecologists with good knowledge of the Bog's plant communities resulted in broad agreement. Some biological input (sampling of macroinverts and fish) from Area fish and biology teams - but this more to do with the watercourse than the Bog itself. Since 1996 about at least a dozen people have been involved, but mostly on a verbal basis with occasional site visits.

7. Roughly how long did the study take?

A few days  Months  Years, but this is a project which has no defined end point. Its very much a suck it and see project based more on pragmatism and opportunistic involvement by various people.

8. What was the cost?

<£10k  £10-50k  >£50k this is the cost of the restoration works undertaken in 1998. The actual site investigations, survey and monitoring undertaken since 1996 probably cost between £10 and £20, mostly in staff time. A handful of dipwells cost pence, but it takes many site visits (to the Island, which costs in travel as well as time) to get a good feel for what is going on.

9. Did the assessment follow a standard procedure?

Yes, please provide details

No I made it up as I went along. This Area has no formal training in EIA, we have no EIA officers and support for a project like this is difficult to pin down. I more-or-less took the site under my wing to make something happen rather than see the Bog quite clearly deteriorate because no one else could be bothered to put the time, effort or money in. This site was suffering considerable neglect, not least because of poor relations between various, poorly informed officers and the land owner, which, over many years, had soured the likelihood of any progress. I had to do a lot of bridge building.

<p>10. Please provide a brief overview of what was done in carrying out the assessment.</p> <p>This one was not rocket science. Fine tuning was not the order of the day. You have a peat wetland (Bog) which appears to be drying out in places and you have a great big drain going through the middle. Stick some dipwells in and, low and behold, you find a nice cone of depression. It was fairly logical what needed doing next.</p>
<p>11. Was the assessment purely desk based, or did it involve site investigation?</p> <p>Both, but mostly field based observation.</p>
<p>12. What data were used, were there enough, were the data representative?</p> <p>To begin with Dipwell data was collected about every month through a year. This showed the greatest impact to water levels during the summer when the cone of depression extended furthest from the drain. High flows (following rainfall events in this very flashy catchment) in the ditch were observed to have a very rapid effect on the water table in the peat, followed by a rapid return to draw down when ditch levels fell again.</p>
<p>13. What, if any, specific tools or models were used in the assessment? How useful were they?</p> <p>None.</p>
<p>14. Was the study successful? What problems arose? How confident were you in the results?</p> <p>Restoration work (to block the main drains) was almost instant in terms of removing the cone of depression in the Bog. The same restoration work needs to be extended to other areas on the same SSSI and I will be installing dipwells shortly to examine the relationship between water tables and proximity to drains.</p>
<p>15. What gaps or needs did you identify? What would help you overcome the problems identified in Qu 14? Score 1-5 (1 =most important, 5 = least important)</p> <p>It would be nice to get a better handle on the potential importance of ground water and what effect the reservoir has or has not had just by being there. I think it may have changed hydrological conditions locally. However, this fine tuning is of little significance whilst there are still significant areas of peat drying out because of main drains taking surface water away. My feeling is that more of the same restoration, with a few dipwells to confirm the effects on water levels is the most pragmatic way forward for this site and will get it 95% of the way there in terms of 'favourable condition'. You could spend a load of money on better understanding the complexities of the site which has a very variable surface geology, hydrology and ecology, but I'm not sure what this will achieve. The biggest obstacle to sorting this site out has been a lack of time and inclination to walk the site, observe what is going on at the surface for all to see, and then do something about it.</p>

## Wetland Impact Assessments

Wetland Name <b>CRYMLYN BOG, SWANSEA (High Priority cSAC and SSSI)</b>	
<p>2. Wetland type</p> <p><input checked="" type="checkbox"/> Fen/reed bed Wet Grassland</p> <p><input checked="" type="checkbox"/> Bog/ mire (upland/lowland) Wet heath Wet woodland Other (please specify)</p>	<p>3. Water source</p> <p><input checked="" type="checkbox"/> Surface-water fed Groundwater fed Combined surface-water/ groundwater fed</p>
<p>4. What question were you trying to answer? ie. the reason for carrying out the assessment, type of impact etc.</p> <p>To determine if any links exist between a canal system within and adjacent to the bog and groundwater levels within the bog area. Also to investigate the nature of these interactions and quantify potential impacts i.e. groundwater rising or falling. The environmental impact of the licensed abstraction supplying the canal is under investigation as part of the Habitats Directive Review of Consents.</p>	
<p>5. What was your conceptual understanding of the wetland system and how certain were you? Did you consider hydrology, hydrogeology, ecology?</p> <p>The site is quite complex and a lot of work was involved ground truthing before a realistic conceptual understanding could be developed. The project is still in early stages of implementation and data collection. It is assumed that the bog is a relatively closed system, with little inter basin hydrogeological influence. The system appears to be primarily surface water fed, with a canal system and associated hydraulic structures potentially acting as the major downstream control on water levels. The study focuses on site hydrology and will involve calculation of a site water balance.</p>	
<p>6. Who did the work (Agency/consultants etc)? How many people were involved and what were their backgrounds (hydrology, hydrogeology, ecology, water quality etc).</p> <p>The project is being carried out in association with the Countryside Council for Wales. The Environment Agency is managing the project with CCW staff contribution being 1 Ecologist and 2 Site Wardens (access permissions, practical site work and data collection). Agency work is being carried out by 1 Licensing Officer (Project management), 1 Hydrologist (technical management &amp; data analysis), 2 Hydrometry staff (instrumentation, data collection and data analysis).</p>	

External contractors have been/will be commissioned for topographic and structures surveys and peizometer installation.
7. Roughly how long did the study take? A few days      Months <b>X</b> Years (Estimated duration 18 months to two years)
8. What was the cost? <£10k <b>X</b> £10-50k      >£50k
9. Did the assessment follow a standard procedure? Yes, please provide details <b>X</b> No (Back of a fag packet procedure)
10. Please provide a brief overview of what was done in carrying out the assessment.  A limited amount of historical groundwater level data were available but of little use without present day comparative data. No current environmental data collection programmes were in place although a limited amount of vegetation mapping has recently been carried out by CCW. It was therefore necessary to initiate a completely new monitoring programme to collect baseline hydrological and hydrogeological information.  To provide enough information for a basic water balance and determine canal-bog interactions the following assessment work is underway: quantification of inflows to the site, based on streamflow measurement (V notch weir and current meterings) and rainfall-runoff estimation (from rainfall totals recorded at the site rain gauge) measurement of surface water losses from the system (assuming all surface water is discharged via the canal) using stage discharge equations for canal control structures linked to canal stage logger and calibration current meterings. Estimation of evaporative losses from evapotranspiration derived from data collected at automatic weather station. Monitoring groundwater levels over a network of piezometers recently installed. Topographic survey to provide absolute levels for canal structures, piezometer datum pins and canal cross sections. Structures survey to provide information from which stage-discharge equations are derived.
11. Was the assessment purely desk based, or did it involve site investigation?  The study has, so far, been very much field orientated with the collection of new data. The issues are complicated further by decommissioning of an oil refinery alongside the bog with associated site remediation and changes to the industrial drainage system. Considerable time has been spent on liaison with CCW and the oil company with regards access permissions and data requirements. Environmental monitoring requires monthly staff time of about 5 man days. However with a data set developing, emphasis will move now to office based analysis.

12. What data were used, were there enough, were the data representative?

Monthly groundwater data for a range of sites are available for a 5 years period up to 1990. This data seems to be of good quality but requires comparison with present day data as changes have been made in the intermediate period to bog drainage and canal operation.

The current data collection programme beginning 1 Jan 2003 will provide:

- Fortnightly groundwater levels (mAOD) at 12 piezometers throughout the site.
- 15 min canal stage data ( measured at short intervals to capture variations in operational levels and response to rainfall events. This will enable a total volume passing over discharge structures to be determined.)
- Monthly spot gaugings on stream inflows
- 15 minute flow data from one V-notch and stage logger installed on a representative catchment
- Monthly storage and logged tipping bucket rain gauge data.
- 5 minute maximum, minimum, humidity, solar radiation, wind speed data from automatic weather station (to be installed shortly)

Remote sensing data for bog vegetation collected at the same time as the 1985 to 1990 groundwater are apparently available and currently being sourced. 2001 digital aerial photography is also available for comparison.

13. What, if any, specific tools or models were used in the assessment? How useful were they?

It had been proposed to use a Modelmaker software package as a framework for the water balance although software convergence problems may prevent this.

14. Was the study successful? What problems arose? How confident were you in the results?

The study has yet to be completed although most problems and delays to date have been associated with land access permissions, practical implementation of site work, i.e. transport of materials, cable checks and field staff availability, corporate issues such as delays associated with procurement, policy, finance etc.



15. What gaps or needs did you identify? What would help you overcome the problems identified in Qu 14? Score 1-5 (1 =most important, 5 = least important)

Project management guidance to include practical considerations - 2

Project management guidance to include a summary of relevant procurement procedures - 1

Technical guidance on wetland investigation methodologies - 2

Technical guidance on instrumentation available for data collection - 2

Case studies - 3

## Wetland Impact Assessments

1. Wetland Name: <b>Dartmoor</b>		
2. Wetland type		3. Water source
Fen/reed bed Wet Grassland <input checked="" type="checkbox"/> Bog/ mire (upland/lowland) <input checked="" type="checkbox"/> Wet heath Wet woodland Other (please specify)		Surface-water fed Groundwater fed <input checked="" type="checkbox"/> Combined surface-water/ groundwater fed
4. What question were you trying to answer? ie. the reason for carrying out the assessment, type of impact etc.		
Review of existing abstractions required under Habitats Directive legislation, to assess whether they are having an unacceptable impact on designated species - blanket bog, wet heath and southern damselfly.		
5. What was your conceptual understanding of the wetland system and how certain were you? Did you consider hydrology, hydrogeology, ecology?		
Generally, the mechanism of impact is a reduction in groundwater levels as a result of (non returned) surface water or groundwater abstractions. Specific conceptual models for individual sites were not developed for Stage 2 of the review work (e.g. whether there is hydraulic continuity between areas of wet heath and underlying aquifer).		
6. Who did the work (Agency/consultants etc)? How many people were involved and what were their backgrounds (hydrology, hydrogeology, ecology, water quality etc).		
Agency hydrologist carried out Stage 1 of the review - a very broad brush determination of "relevant licences" using surface catchment boundaries.  Consultants carried out Stage 2 of the review, which was a slightly more detailed desk study using criteria based on abstraction volume, and distance from wetland site (for gw licences) or licensed volume as a percentage of flow in the watercourse.		
7. Roughly how long did the study take?		
<input checked="" type="checkbox"/> A few days over a period of 3.5 years.      Months      Years		

<p><b>8. What was the cost?</b></p> <p>X &lt;£10k      £10-50k      &gt;£50k</p>
<p><b>9. Did the assessment follow a standard procedure?</b></p> <p>? Yes, please provide details in as much as we referred to the Agency guidance available for HD review work (but this was not detailed), and we carried out a Stage 1 review followed by a more detailed Stage 2 review.</p> <p>No</p>
<p><b>10. Please provide a brief overview of what was done in carrying out the assessment.</b></p> <p>Consultants used licence volumes from the Agency, existing hydrogeology information and professional judgement to make conservative estimates of zones of impact of groundwater abstractions. Surface water abstraction volumes were assessed and compared to (theoretical) flow levels in watercourses.</p>
<p><b>11. Was the assessment purely desk based, or did it involve site investigation?</b></p> <p>Purely desk based.</p>
<p><b>12. What data were used, were there enough, were the data representative?</b></p> <p>No site specific flow or level data have been measured so far. At Stage 3 (detailed assessment) this may be necessary. This stage of work must be completed by April 2006 for this site.</p> <p>Data used were those already available - licensed volumes (not actual abstractions), hydrogeology data from maps etc.</p>
<p><b>13. What, if any, specific tools or models were used in the assessment? How useful were they?</b></p> <p>GIS tools (Arcview). Excel.</p>
<p><b>14. Was the study successful? What problems arose? How confident were you in the results?</b></p> <p>The work is ongoing.</p> <p>We could have undertaken the consultants' Stage 2 work, which was straightforward, with guidance. Results so far are conservative, and as such, reliable. Possibly the results of Stage 2 should have been more detailed and site specific.</p> <p>Further work needed to determine impact at specific sites. Problems associated with identifying exactly what monitoring is needed and what will</p>

count as significant impact (related to more detailed conceptual model, and also quantitative information on susceptibility of wetlands and designated features, clear objective needed). Relatively large area of wetland to be monitored.

**15. What gaps or needs did you identify? What would help you overcome the problems identified in Qu 14? Score 1-5 (1 = most important, 5 = least important)**

Information on previous wetland assessment studies and how monitoring analysis was carried out.

? Workshop to discuss the above for relevant staff who will be doing assessment work.

Standard, but more detailed, guidance or pointers on procedures for assessment, how to establish monitoring needs (scale, and timing).

Early consideration of monitoring requirements - since several years' data will be needed.

## Wetland Impact Assessments

1. Wetland Name Derwent Valley SPA and cSAC	
2. Wetland type	3. Water source
<input checked="" type="checkbox"/> Fen/reed bed ( <b>Phalaris, Glyceria</b> ) <input type="checkbox"/> Wet Grassland ( <b>lowland hay meadows MG4 grassland</b> ) Bog/ mire (upland/lowland) Wet heath <input checked="" type="checkbox"/> Wet woodland ( <b>alluvial forest with alder and ash</b> ) Other (please specify)	<input checked="" type="checkbox"/> Surface-water fed Groundwater fed Combined surface-water/ groundwater fed
4. What question were you trying to answer? ie. the reason for carrying out the assessment, type of impact etc.	
<p>Initially to understand the impact of abstractions on the river and its floodplain to produce guidance for the sustainable management of water resources in the Lower Derwent Valley, following concerns about potential drought impacts. Expanded to encompass an assessment of the impact of drainage and the Barmby Barrage, the latter meeting a High Court Consent Order to assess the impact of the barrage on the MG4 grassland. The work is also needed to assess the impact of permissions for the Habitats Directive Review of Consents. The current phase aims to determine the relationship between the ecological indicators, and the factors that influence them on individual ings, examine the impact of the operation of the barrage on these indicators and produce practical guidance for management. It includes both water and nutrient budgets.</p>	
5. What was your conceptual understanding of the wetland system and how certain were you? Did you consider hydrology, hydrogeology, ecology?	
<p>A surface water system with bird and grassland main interest features and a limited understanding of river and floodplain interactions. The project examined the river and floodplain linkage and included hydrology and hydrodynamics, water quality, structures e.g. flapped outfalls, weirs, soils, ecology, historical and current farming practices.</p>	
6. Who did the work (Agency/consultants etc)? How many people were involved and what were their backgrounds (hydrology, hydrogeology, ecology, water quality etc).	
<p>The work was carried out as a partnership project with YWS Ltd, English Nature, the Agency and latterly the Internal Drainage Boards forming a Project Board and the Agency Project Managing. There were two sub groups reporting to the Project Board,</p>	

<p>comprising hydrology and ecology experts from within the partnership; internal water quality modellers were also involved with the nutrient modelling. There was also a database of consultees and focus groups involving other organisations such as Yorkshire Wildlife Trust and the RSPB. The Project Board and subgroups developed the process and completed some of the ecology work. The majority of the work was carried out by various consultants, with one firm of Consulting Engineers used throughout for modelling and integrating ecology and other information. Individual contracts were used for topographic, soils and ecological surveys, farming practices work and nutrient modelling. Experts were also used in an advisory capacity via workshops or direct commission. The Agency National Centre provide the Lidar data, which was obtained for both project and flood defence purposes.</p>
<p>7. Roughly how long did the study take?  A few days      Months      <input checked="" type="checkbox"/> 6      Years</p>
<p>8. What was the cost?  &lt;£10k      £10-50k      <input checked="" type="checkbox"/> &gt;£50k</p>
<p>9. Did the assessment follow a standard procedure?  Yes, please provide details  <input checked="" type="checkbox"/> No The process was developed by the Project Board and evolved and expanded over time to meet requirements and accommodate new components e.g. Habitats Directive Review of Consents and implications of findings</p>
<p>10. Please provide a brief overview of what was done in carrying out the assessment.</p> <p>Initial data were collected supplemented by surveys to develop a MIKE 11 and HYSIM model. In parallel a conceptual ecological model was produced. The two were then linked to assess the impact of abstractions on the river levels and ecology using worst case and current and no abstraction scenarios. The work was then expanded to cover both river and floodplain developing the model further and collecting additional information on topography, structure and drain dimensions, soils and ecology. This was then used to assess the interrelationships. Best available expert information was used on requirements of interest features. Vegetation data were reviewed over time.</p>
<p>11. Was the assessment purely desk based, or did it involve site investigation?  Desk plus site investigation and survey</p>
<p>12. What data were used, were there enough, were the data representative?  Data were used and that collected over the time scale of the project ensured a representative range of wet and dry years and a comprehensive set of data to work with in order to cover individual floodplain units and the river.</p>
<p>13. What, if any, specific tools or models were used in the assessment? How useful were they?</p>

HYSIM & MIKE 11 models, experiential ecological model, GIS layering, CATNAP nutrient model.

14. Was the study successful? What problems arose? How confident were you in the results?

The project is currently completing the second phase focusing on drainage. The first phase successfully assessed impact of abstraction on river. Indications are that second phase will establish cause and effect and focus what management actions are needed. It will also help to sharpen conservation targets. Nutrient modelling is pinpointing actions needed on the river and nutrient dynamic work is being developed this year to link the river and floodplain, following some initial analysis of hay samples and sediments from the floodplain. The Project Board have worked very well together and benefited from each others technical and business skills.

15. What gaps or needs did you identify? What would help you overcome the problems identified in Qu 14? Score 1-5 (1 =most important, 5 = least important)

We have filled the gaps as we have gone along e.g. comprehensive NVC survey information. We are now at the stage of beginning to consider options and associated risks and monitoring requirements associated with any actions. We are limited by how good the data are over a longer period of time in evaluating changes, for example in vegetation over time in relation to target setting. We will be disseminating the findings to interested parties in the valley and working with them to develop management plans and help implement actions.

## Wetland Impact Assessments

1. Wetland Name Dorset Heaths	
2. Wetland type	3. Water source
<ul style="list-style-type: none"> <li>✓ Fen/reed bed</li> <li>Wet Grassland</li> <li>✓ Bog/ mire (upland/lowland)</li> <li>✓ Wet heath</li> <li>Wet woodland</li> <li>Other (please specify)</li> </ul>	<ul style="list-style-type: none"> <li>Surface-water fed</li> <li>Groundwater fed</li> <li>✓ Combined surface-water/ groundwater fed</li> </ul>
4. What question were you trying to answer? ie. the reason for carrying out the assessment, type of impact etc.	
<p>Determine if abstractions were having an impact on any of the 43 composite SSSIs within the Dorset Heaths network for Stage 2 of the Review of Consents</p>	
5. What was your conceptual understanding of the wetland system and how certain were you? Did you consider hydrology, hydrogeology, ecology?	
<p>Most of the wet features on the Dorset Heaths appear to be perched on relatively impermeable soils over the main aquifer, receiving surface water runoff and with restricted vertical movement. Certain.</p>	
6. Who did the work (Agency/consultants etc)? How many people were involved and what were their backgrounds (hydrology, hydrogeology, ecology, water quality etc).	
<p>Internal Agency (Helen Lawrie) and Marcus Hodges Environmental (Dave Gibson). Both hydrogeologists.</p>	
7. Roughly how long did the study take?	
<p>A few days    ✓    Months    Years</p>	
8. What was the cost?	
<p>&lt;£10k    <span style="background-color: #ff00ff;">█</span>    £10-50k    &gt;£50k</p>	
9. Did the assessment follow a standard procedure?	
<p>✓ Yes, please provide details <a href="#">See attached proforma</a></p> <p>No</p>	
10. Please provide a brief overview of what was done in carrying out the assessment.	



<p>The site was characterised using OS maps, habitat maps, geology and hydrogeology maps and cross sections. The available data were used to produce a simple conceptual model and assess potential interaction between the consents and the wet features of the site. If no potential for interaction was identified then the consent was excluded from further study. No quantitative analysis was undertaken.</p>
<p>11. Was the assessment purely desk based, or did it involve site investigation?</p> <p>Stage 2 was desk based.</p>
<p>12. What data were used, were there enough, were the data representative?</p> <p>The desk based study did not include any quantitative analysis. This is to be part of Stage 3. The data used were to provide a simple qualitative conceptual model for each site.</p>
<p>13. What, if any, specific tools or models were used in the assessment? How useful were they?</p> <p>None</p>
<p>14. Was the study successful? What problems arose? How confident were you in the results?</p> <p>The assessment predicted the potential for impact but made no attempt to quantify it or evaluate the significance. Confident in results.</p>
<p>15. What gaps or needs did you identify? What would help you overcome the problems identified in Qu 14? Score 1-5 (1 =most important, 5 = least important)</p> <p>No standard procedure exists hence the production of the proforma. The Stage 2 review identified that a generic study is not applicable for Stage 3. The sites and consents all require site specific further quantitative investigation which is of a different level and type depending on the identified issue. Therefore although a standard procedure was of importance for Stage 2, it is no longer applicable and a data collection programme and a simple tool are of more importance. The Dorset Heaths wet features mostly occur on relatively impermeable, waterlogged soils therefore guidance/information on soil hydrology, matrix potentials and calculating the amount of drawdown in the underlying aquifer to induce leakage would be extremely useful.</p>

## Wetland Impact Assessments

1. Wetland Name East Devon Pebble Bed Heaths cSAC	
2. Wetland type Fen/reed bed Wet Grassland Bog/ mire (upland/lowland) Wet heath Wet woodland <b><i>Other - Dry heath with valley wetlands</i></b>	3. Water source  Surface-water fed <b><i>Groundwater fed</i></b> Combined surface-water/ groundwater fed
4. What question were you trying to answer? ie. the reason for carrying out the assessment, type of impact etc.  <i>Needed to assess the impacts of existing licensed GW &amp; SW abstractions on wetland habitats within the designated SAC and their significance, as part of the Review of Consents under the Habitats Directive. If the study showed these to be significant it should identify actions needed to effects become insignificant.</i>	
5. What was your conceptual understanding of the wetland system and how certain were you? Did you consider hydrology, hydrogeology, ecology?  <i><u>Ecology</u>: EN already had a habitat study that defined wetland plant communities and their locations. Status of site was favourable. <u>Hydrogeology</u>: Desk study supported by site visits confirmed expectation that valley bottom wetlands are sustained by emergent GW seepage areas and spring issues from Pebble Bed strata. Inspections confirmed that seepage faces and springs align with lowermost levels of Pebble Beds strata and emerge adjacent to where erosion has removed aquifer and exposed underlying Permian Marl aquiclude. <u>Hydrology</u>: Flow accretion profiles and recession characteristics established by historical data analysis supplemented by targeted three month spot gauging study.</i>	
6. Who did the work (Agency/consultants etc)? How many people were involved and what were their backgrounds (hydrology, hydrogeology, ecology, water quality etc).  <i><u>Consultants</u>: Site ecology and habitat study <u>EA</u>: Hydrological and hydrological study and report; recommendations for actions to ensure current favourable conservation status of site is maintained. <u>EN</u>: Subsequent review of conclusions of hydrogeological/hydrological study and negotiation for changes with water company.</i>	

<p>7. Roughly how long did the study take?</p> <p>A few days      <b>Months</b>      Years</p>
<p>8. What was the cost?</p> <p>&lt;£10k      <b>£10-50k</b>      &gt;£50k (Staff time for site inspections, plus</p>
<p>9. Did the assessment follow a standard procedure?</p> <p><b>Yes</b>, please provide details</p> <p><i>Used Review of Consents Stage 2 assessment process combined with standard hydrological and hydrogeological techniques for investigating and predicting abstraction impact effects.(See 13. Below)</i></p> <p>No</p>
<p>10. Please provide a brief overview of what was done in carrying out the assessment</p> <p><i>This study looked at the hydrological impact mechanisms and their sensitivity to abstractive impacts. It was carried out by an experienced hydrogeologist who had an excellent working knowledge of the area and the strata involved and taking into account the results of stream flow gauging studies along the small valley systems that were organised and analysed by a hydrologist.</i></p> <p><i>An expert opinion was provided on the significance of the abstractions with a recommendation on what (if any) action was needed to ensure site remained in favourable condition.</i></p>
<p>11. Was the assessment purely desk based, or did it involve site investigation?</p> <p><i>Site investigation had already been carried out to identify sensitive species and habitat locations</i></p> <p><i>Desk-based hydrogeological assessment first, followed by site inspections (3 days) and spot gaugings over a three month period and their subsequent analysis.</i></p>
<p>12. What data were used, were there enough, were the data representative?</p> <p><i>Historic data and knowledge of the aquifer and its hydrological responses was used, together with some limited long term flow gaugings. The latter were augmented by a three month local flow monitoring study.</i></p>
<p>13. What, if any, specific tools or models were used in the assessment? How useful were they?</p> <p><i>Standard hydrogeological drawdown vs.distance and recession analytical techniques</i></p>

14. Was the study successful? What problems arose? How confident were you in the results?

*Outcome was successful:*

*Difficulty in establishing sensitivities of particular species to changes in water availability were not necessary because arguments based on hydrogeological impact mechanisms were sufficient in this case.*

*Impacts of small private sources judged to be insignificant (Note the paperwork has to be endorsed by EN).*

*Preference for cessation of historic, continuous spring flow/stream intake abstractions that transfer water out of the catchment by underground pipeline, despite lack of firm evidence of their unacceptability. Water company was supportive and carried out agreed works to permanently close off the intakes.*

15. What gaps or needs did you identify? What would help you overcome the problems identified in Q14? Score 1-5 (1 = most important, 5 = least important)

*Knowledge of water availability sensitivities of critical wetland species - 3*

*Simpler tools for assessing impact of groundwater abstractions on wetlands - 3*

## Wetland Impact Assessments

1. Wetland Name EMER BOG cSAC	
2. Wetland type	3. Water source
<p>** Fen/reed bed Wet Grassland</p> <p>** Bog/ mire (upland/lowland**)</p> <p>** Wet heath</p> <p>** Wet woodland</p> <p>** Other (please specify) Ponds and swamp</p>	<p>Surface-water fed</p> <p>Groundwater fed</p> <p>** Combined surface-water/ groundwater fed</p>
4. What question were you trying to answer? ie. the reason for carrying out the assessment, type of impact etc.	
<p>To assess the likelihood that discharges licences, when considered alone or in combination, were adversely affecting the integrity of Emer Bog cSAC</p>	
5. What was your conceptual understanding of the wetland system and how certain were you? Did you consider hydrology, hydrogeology, ecology?	
<p>Earlier field work work had indicated that the site was nutrient enriched and that there were contrasts in water reaction around the site with strongly acidic and alkaline surface flows and wetlands. Relationships between groundwater flow and surface water flow were uncertain. Studies demonstrated flows into, across and out of the mire/fen system and those areas enriched in P and N and revealed the shape of the peat basins and their relationships to wetland wildlife habitats.</p>	
6. Who did the work (Agency/consultants etc)? How many people were involved and what were their backgrounds (hydrology, hydrogeology, ecology, water quality etc).	
<p>Work primarily undertaken by consultant hydro-ecologist with skills in field mapping, soil and peat science, water chemistry and geology/hydrogeology and wetland wildlife habitat assessment, assisted in field by nature reserve warden. Topographic surveying of the wetland areas was undertaken by a firm of topographic surveyors working to a specific brief.</p>	
7. Roughly how long did the study take?	
<p>A few days    **    Months    Years</p>	
8. What was the cost?	
<p>&lt;£10k    **    £10-50k    &gt;£50k</p>	

<p>9. Did the assessment follow a standard procedure?</p> <p>Yes, please provide details</p> <p><b>**</b> No Procedures were bespoke and developed for this site.</p>
<p>10. Please provide a brief overview of what was done in carrying out the assessment.</p> <p>A detailed desk study had been previously undertaken and also studies about 10 years previously. Desk study and earlier work were reviewed and a programme of field work agreed to address issues raised. Results of desk study and field programme were carefully assessed and reported upon.</p> <p>These studies included detailed field mapping of surface hydrology, interpretation of hydrogeology, wildlife habitat distribution, soil types and water regimes, and peat depths and type together with hydrochemistry (both seasonal and in comparison with earlier studies). The study was considerably assisted by a specially commissioned topographic survey and which allowed detailed mapping of hydro-ecological features in a remote site. Plotting of data on the topographic base allowed relationships to be assessed.</p>
<p>11. Was the assessment purely desk based, or did it involve site investigation?</p> <p>Desk based followed by a substantial field investigation. Field investigation probably involved about 10 days.</p>
<p>12. What data were used, were there enough, were the data representative?</p> <p>Previous water chemistry and dipwell data were assessed, coupled with a new programme of water sampling from autumn and winter studies, site substrate, surface hydrology and soil investigation. Adequate information was obtained to gain an understanding of the hydro-ecological relationships of the site.</p>
<p>13. What, if any, specific tools or models were used in the assessment? How useful were they?</p> <p>Tools in the field involved field mapping skills, topographic survey use of soil/peat augers and water sampling from surface waters</p> <p>Models were paper based using detailed plotting of peat depths, water chemistry characteristics, geology and wetland habitats in relation to hydrology, boreholes and topography.</p>
<p>14. Was the study successful? What problems arose? How confident were you in the results?</p> <p>The study was successful and no problems arose</p> <p>The assessment demonstrated that the discharge licences being assessed in the Review of Consents, when considered alone or in combination, are not adversely affecting the ecological integrity of Emer Bog cSAC.</p>

The matter of nutrient enrichment and apparent changes in water chemistry/acidity across the site with time were almost certainly due to other factors (historic, hydro-geological, agricultural or other) unrelated to the consented discharges.

**15. What gaps or needs did you identify? What would help you overcome the problems identified in Qu 14? Score 1-5 (1 =most important, 5 = least important)**

Considering the nature of the discharges and the hydrological characteristics of the site and substrate, further confirmatory studies would not be cost effective and unlikely to yield additional critical or issue specific information.

Hydrological and hydrochemical conditions, unrelated to the consented discharges, are very likely to be having an adverse effect on the special characteristics of this wetland cSAC/SSSI and nature reserve. Botanical and hydro-chemical monitoring is recommended as the key to further understanding changes occurring at this site.

## Wetland Impact Assessments

<p>1. Wetland Name Exmoor (MIRE Project)</p>	
<p>2. Wetland type</p> <p>Fen/reed bed</p> <p>Wet Grassland</p> <p>✓ Bog/ mire (upland/lowland)</p> <p>Wet heath</p> <p>Wet woodland</p> <p>Other (please specify)</p>	<p>3. Water source</p> <p>Surface-water fed</p> <p>Groundwater fed</p> <p>✓ Combined surface-water/ groundwater fed</p>
<p>4. What question were you trying to answer? ie. the reason for carrying out the assessment, type of impact etc.</p> <p><b>1. Whether the creation of large ditches on Exmoor had contributed to a more flashy regime in the River Exe, and hence whether blocking the ditches would reverse this effect.</b></p> <p><b>2. Whether blocking the ditches that drain the mire would have the effect of raising the water table and hence increasing the abundance of mire plants and communities.</b></p>	
<p>5. What was your conceptual understanding of the wetland system and how certain were you? Did you consider hydrology, hydrogeology, ecology?</p> <p><b>It was assumed that the blocking the ditches would raise the water level in the ditch and hence the water level in the mire. Staff gauges were installed in the ditch and dipwells in the fields adjacent to the ditches to provide data to confirm this assumption - monitoring equipment was installed at two sites, one to be used as a control and the other to have its ditches blocked. Data were collected for two years before the ditches were blocked and then for a similar time after ditch blocking and for the same period at the control site.</b></p>	
<p>6. Who did the work (Agency/consultants etc)? How many people were involved and what were their backgrounds (hydrology, hydrogeology, ecology, water quality etc).</p> <p><b>Agency hydrometric staff installed the monitoring equipment and undertook the monitoring on a monthly basis over 5 years.</b></p> <p><b>Agency ecologists, a hydrogeologist and hydrologist were involved in the set up of the project.</b></p> <p><b>Exmoor National Park staff installed the dams that blocked the ditches.</b></p>	



<p><b>Staff from the Agency, English Nature, ENPA and DEFRA on the project board. Agency hydrologist analysed hydrological data obtained during the project.</b></p>
<p>7. Roughly how long did the study take?  A few days      Months    <input checked="" type="checkbox"/> Years</p>
<p>8. What was the cost?  &lt;£10k    <input checked="" type="checkbox"/> £10-50k    &gt;£50k</p>
<p>9. Did the assessment follow a standard procedure?  Yes, please provide details  <input checked="" type="checkbox"/> No</p>
<p>10. Please provide a brief overview of what was done in carrying out the assessment.</p> <p><b>Ditch water level data and water table data from the dipwells for the period before the ditches were blocked were compared to the data collected after the ditches were blocked to ascertain whether the water table was higher after the change. The Hydrologist undertook statistical testing to determine whether the effect, if any, was significant.</b></p> <p><b>Conservation Officers from the Agency and English Nature visited the site to observe the plant species/communities present approximately 2 years after blocking the ditches.</b></p>
<p>11. Was the assessment purely desk based, or did it involve site investigation?</p> <p><b>The hydrological analysis was desk-based. Subjective assessment of the vegetation change was made by Conservation Officers on a site visit.</b></p>
<p>12. What data were used, were there enough, were the data representative?</p> <p><b>Nearly 5 years water table data and ditch water level data were available for the site; the ditches were blocked approximately half way through the time period. Data for a transect of 12 dipwells were available for manually dipped wells. Three of the dipwells were logged using pressure transducers but harsh weather conditions, vandalism and damage by animals at regular intervals through out the recording period meant that there is much missing data.</b></p> <p><b>Due to the year before the ditch blocking being extremely wet and the year after being extremely dry, any change in water table height that may have been caused by blocking the ditches was masked by the climatic conditions. Data were not collected for long enough before the ditches were blocked and consequently the 'baseline' dataset was not representative.</b></p> <p><b>Spatial coverage was good, and well thought out. Data were needed over a longer time period before the ditches were blocked.</b></p>
<p>13. What, if any, specific tools or models were used in the assessment? How useful were they?</p>

**The Minitab statistical analysis package. Extremely powerful and useful package.**

14. Was the study successful? What problems arose? How confident were you in the results?

**The baseline dataset at the ditch-blocked site proved to be not representative of the true long term condition experienced at the site. The aim of the project had been to demonstrate an increase in the water table level. In fact it was possible to demonstrate a statistically significant decrease in the water table after blocking the ditches.**

**Further analysis was undertaken to ascertain whether it is possible to use the data from the control site as a baseline, block the ditches at this site and measure any impact against the longer baseline of 5 years. Further monitoring will be required at this site to demonstrate a change in the water table against this longer, representative baseline dataset.**

15. What gaps or needs did you identify? What would help you overcome the problems identified in Qu 14? Score 1-5 (1 =most important, 5 = least important)

**A set of guidelines indicating the length of time required for monitoring water tables before a change is made, frequency of observations necessary etc would be useful - 2.**

## Wetland Impact Assessments

1. Wetland Name Fenns, Whixall, Wem Cadne & Bettisfield Moss	
2. Wetland type  Fen/reed bed Wet Grassland <input checked="" type="checkbox"/> Bog/ mire (upland/lowland) Wet heath Wet woodland Other (please specify)	3. Water source  Surface-water fed Groundwater fed Combined surface-water/ groundwater fed Mainly rainfall with some groundwater influence. Site needs nutrient poor water.
4. What question were you trying to answer? ie. the reason for carrying out the assessment, type of impact etc..  The aim of the investigation is to further develop the Agency's understanding of the groundwater system beneath, and in the vicinity of, the Fenns and Whixall Moss. This will be used to determine the vulnerability of the Moss to groundwater abstractions. Stage 3 assessment as part of the Habitats Directive.	
5. What was your conceptual understanding of the wetland system and how certain were you? Did you consider hydrology, hydrogeology, ecology?  EN had already data and basic conceptual models on the site but the hydrogeology needed to have more investigation. Hydrology, hydrogeology, ecology, water quality was considered as part of the study.	
6. Who did the work (Agency/consultants etc)? How many people were involved and what were their backgrounds (hydrology, hydrogeology, ecology, water quality etc).  Agency Project Team - Hydrologist (Project Manager), Hydrogeologist (from Midlands and EA Wales) Consultants to collate the data, undertake some field work and write the report - hydrogeologists and GIS work. EN staff - Site manager and CO for the area. Technical Specialist - Hydrologist who had worked for EN on the site and very familiar with the site.	
7. Roughly how long did the study take?  A few days      Months <b>1</b> Years	

8. What was the cost? <input type="checkbox"/> <£10k <input checked="" type="checkbox"/> £10-50k <input type="checkbox"/> >£50k
9. Did the assessment follow a standard procedure? Yes, please provide details <input checked="" type="checkbox"/> No
10. Please provide a brief overview of what was done in carrying out the assessment.  This will require the following steps: <ul style="list-style-type: none"> <li>• Startup meeting at the Agency's offices in Shrewsbury and a subsequent meeting at Fenns and Whixall with English Nature.</li> <li>• Review of the existing data held by the Agency and other organisations, including: <ul style="list-style-type: none"> <li>– Existing reports on the Moss undertaken on behalf of the Agency and English Nature,</li> <li>– External reports, particularly on the geology of the area, for example reports on for sand and gravel resources undertaken in the 1980s,</li> <li>– All the available geological logs from boreholes in the area. It is expected that most of this will be held by the Agency and English Nature, but some provision may be required for obtaining additional data from the British Geological Survey,</li> <li>– Water level measurements from within the site and the surrounding area. This will include data from monitoring undertaken by English Nature within the SSSI, monitoring undertaken by the Agency adjacent to Wardle Metals, on Wem Moss and at the Roving Bridge scrap yard,</li> <li>– Abstraction records, where these are available,</li> <li>– Search of local authority records to establish the presence of any unlicensed abstractions,</li> <li>– Flow gauging records of outflows from the Moss.</li> </ul> </li> <li>• Groundwater monitoring. This will include the monitoring of water levels on a monthly basis in the 22 wells identified by the Agency. In addition, seven boreholes located along the line of the Shropshire Union Canal are dived at the same time. These boreholes were constructed on behalf of British Waterways (BW) and the Agency obtained permission for these to be added to the monitoring network. As the draft report is due in January 2003, it is anticipated that four visits to the monitoring boreholes will be made. Due to the seven BW boreholes being accessible on foot only, it has been assumed that the monitoring round will take more than 1 day to complete.</li> <li>• Additional fieldwork may be necessary, particularly in respect of identifying where the peat body is underlain by sand and where this is replaced by glacial or lacustrine clay. The extent of this work is likely to be more certain after a review of the existing data and following discussions with English Nature.</li> </ul> There may also be a need for some spot flow measurements at the outflows from the Moss. The necessity for this will be reviewed after the initial data have been studied.. It may also be advantageous to undertake some geophysical logging on selected boreholes with no geological records in order to obtain sufficient information to adequately define the superficial geology. A decision on this can be made following an evaluation of the existing geological data.

- The data collected will be used to develop an understanding of the geology of the superficial deposits and the groundwater flow direction within the permeable deposits beneath the site and in the surrounding area. This understanding will be expressed in the form of cross sections and groundwater contour maps. A conceptual model of the site and the surrounding area will be developed and used to assess the potential impact of licensed and unlicensed groundwater abstractions on the Moss. Where applicable scoping calculations will be made to determine likely impacts. Consideration of recharge to the Moss and the superficial aquifer will be undertaken in order to put the abstractions in the context of the overall water budget of the area. In this regard it may be possible to make use of work already being undertaken in connection with the Shropshire groundwater modelling project. A comprehensive report will be completed, detailing the data available, the current understanding of the superficial geology and groundwater flow system. The potential for groundwater abstractions to impact on the Moss will be detailed together with any outstanding uncertainties and recommendations for accounting for these.

11. Was the assessment purely desk based, or did it involve site investigation?

Initially desk based, then site visit, some coring work and other monitoring.

12. What data were used, were there enough, were the data representative?

See 10.

13. What, if any, specific tools or models were used in the assessment? How useful were they?

LIDAR data, Auger, basic groundwater levels etc.

14. Was the study successful? What problems arose? How confident were you in the results?

Report has been reviewed in draft stage and has illuminated the impact of abstraction on the moss - as originally thought. Once EN and Agency agree then this site will be signed off at stage 3.

15. What gaps or needs did you identify? What would help you overcome the problems identified in Q14? Score 1-5 (1 = most important, 5 = least important)

Standard procedures are useful BUT each site needs to be considered on its own merits and so the procedures need to be flexible - a common sense approach is best.

## Wetland Impact Assessments

1. Wetland Name <b>Great Cressingham Fen (Norfolk Valley Fens cSAC)</b>	
2. Wetland type  <input checked="" type="checkbox"/> Fen/reed bed Wet Grassland Bog/ mire (upland/lowland) Wet heath Wet woodland Other (please specify)	3. Water source  Surface-water fed <input checked="" type="checkbox"/> Groundwater fed Combined surface-water/ groundwater fed
4. <b>What question were you trying to answer?</b> ie. the reason for carrying out the assessment, type of impact etc.  <b>Whether the proposed abstraction would affect the integrity of the site under Habs Regs as an appropriate assessment. Focused on flow/water table requirements of what was perceived as the most sensitive habitat feature</b>	
5. <b>What was your conceptual understanding of the wetland system and how certain were you?</b> Did you consider hydrology, hydrogeology, ecology?  <b>It was assumed that the wetland was in hydrological contact with the aquifer. Monitored borehole levels &amp; observed flows were considered. The topography &amp; ecology of the interest feature were considered.</b>	
6. <b>Who did the work (Agency/consultants etc)?</b> How many people were involved and what were their backgrounds (hydrology, hydrogeology, ecology, water quality etc).  <b>Agency WR licensing &amp; hydro-geologist. 2 at any one time, excluding auditing function by team leaders.</b>	
7. <b>Roughly how long did the study take?</b> A few days      Months      Years <b>Several weeks</b>	
8. <b>What was the cost?</b> <£10k      £10-50k      >£50k <b>not quantified</b>	
9. <b>Did the assessment follow a standard procedure?</b> Yes, please provide details <input checked="" type="checkbox"/> <b>No Appropriate assessment can be supplied.</b>	

<p><b>10. Please provide a brief overview of what was done in carrying out the assessment.</b></p> <p>Available data were used to examine the relationship between g/w levels and ditch flow. The ecological impact was considered by the licensing team in consultation with EN.</p>
<p><b>11. Was the assessment purely desk based, or did it involve site investigation?</b></p> <p>Mainly desk based. Additional information from EN (NUC map) and other applicants in area (topography).</p>
<p><b>12. What data were used, were there enough, were the data representative?</b></p> <p>Groundwater level data from more than one borehole, Chalk &amp; drift. No groundwater level data available from the centre of the site to enable estimates of seepage into the site.</p>
<p><b>13. What, if any, specific tools or models were used in the assessment? How useful were they?</b></p> <p>Theis - to give predicted drawdown, acknowledged as inexact. Graphical relationship between groundwater level and stream flow - real data. Estimation from monitored water level data &amp; predicted drawdown and preferred water level of sp. What effect of abstraction.</p>
<p><b>14. Was the study successful? What problems arose? How confident were you in the results?</b></p> <p>Lack of confidence of no effect resulted in refusal of the application. Theis drawdown used as a fall-back position. More realistic predictions of drawdown and ecological monitoring in conjunctions with near-surface water level monitoring in the long term required.</p>
<p><b>15. What gaps or needs did you identify? What would help you overcome the problems identified in Qu 14? Score 1-5 (1 =most important, 5 = least important)</b></p> <p>data collection programme = 1 simple tool for assessment = 2 standard procedure for assessment = 3</p>

Louise Evans

## Wetland Impact Assessments

1. Wetland Name: Isle of Wight Chines (South Wight Maritime cSAC)	
2. Wetland type  Fen/reed bed Wet Grassland Bog/ mire (upland/lowland) Wet heath Wet woodland <input checked="" type="checkbox"/> Other (please specify) Stream gorge through vegetated sea cliffs	3. Water source  Surface-water fed Groundwater fed <input checked="" type="checkbox"/> Combined surface-water/ groundwater fed
4. What question were you trying to answer? ie. the reason for carrying out the assessment, type of impact etc.  Whether abstraction upstream is significantly reducing the rate of erosive processes that maintain the special interest of this cSAC habitat.	
5. What was your conceptual understanding of the wetland system and how certain were you? Did you consider hydrology, hydrogeology, ecology?  It was assumed that the rate of stream erosion might be critical in allowing the nick point at the top of the gorge to keep ahead of the receding face of the sea cliffs.	
6. Who did the work (Agency/consultants etc)? How many people were involved and what were their backgrounds (hydrology, hydrogeology, ecology, water quality etc).  Internal assessment by hydrologist and geomorphologist informed by data collected by external contractor.	
7. Roughly how long did the study take? A few days      Months      Years      Ongoing	
8. What was the cost? <input checked="" type="checkbox"/> <£10k      £10-50k      >£50k	
9. Did the assessment follow a standard procedure? Yes, please provide details <input checked="" type="checkbox"/> No	



<p>10. Please provide a brief overview of what was done in carrying out the assessment.</p> <p>Actual and naturalised catchment flow models were created. The 'loss of erosive power' is being calculated by examining flow and turbidity/bed movement relationships.</p>
<p>11. Was the assessment purely desk based, or did it involve site investigation?</p> <p>Data collection and site familiarisation visits, then desk based modelling study.</p>
<p>12. What data were used, were there enough, were the data representative?</p> <p>Flow readings, accretion gauging studies, turbidity, suspended solids, channel sediment grain size.</p>
<p>13. What, if any, specific tools or models were used in the assessment? How useful were they?</p> <p>Low Flows 2000, Catchmod (in-house rainfall-runoff model).</p>
<p>14. Was the study successful? What problems arose? How confident were you in the results?</p> <p>Study still to complete. Hopeful!</p>
<p>15. What gaps or needs did you identify? What would help you overcome the problems identified in Qu 14? Score 1-5 (1 =most important, 5 = least important)</p> <p>N/A right now.</p>

## Wetland Impact Assessments

1. Wetland Name <b>Kennet and Lambourn Floodplain cSAC</b>	
2. Wetland type	3. Water source
XFen/reed bed Wet Grassland Bog/ mire (upland/lowland) Wet heath Wet woodland Other (please specify)	Surface-water fed Groundwater fed Combined surface-water/ groundwater fed
4. What question were you trying to answer? ie. the reason for carrying out the assessment, type of impact etc.  <b>To assess if regional Groundwater and Surface Water abstractions are having a significant impact on the habitat of the Desmoulin's Whorl Snail. Significance will be defined by a Site Action Group (English Nature, Thames Water, Environment Agency and Atkins) who preside over the project.</b>	
5. What was your conceptual understanding of the wetland system and how certain were you? Did you consider hydrology, hydrogeology, ecology?  <b>The wetland interest features (snails) are dependent (to an unknown extent) on water levels within the peat layer.</b>  <b>We have considered hydrology, hydrogeology and ecology. We have called the technique "the Critical Path" . This path involves defining an impact in hydrological terms and mapping its path through various pathways to end up with an ecological indicator. E.g. abstractions draw down the water table by <math>x\text{cm}</math> which affects the site water balance by <math>y</math> amount which leads to an <math>z\%</math> loss of available habitat which will lead to an <math>x\%</math> reduction in snails.</b>  <b>Our conceptual understanding is that the Peat is in hydraulic continuity with the underlying gravels which in turn are in continuity with the underlying Chalk aquifer. Peat water levels are also dependent on surface water levels in neighbouring water courses. There is a predominance of putty chalk in the upper layers of the chalk which confines the aquifer. There are many impact mechanisms ranging from management of surface water levels by river keepers, regional drawdown of the chalk aquifer affecting the piezometric head of the aquifer beneath the sites and derogation of surface water flow by abstraction.</b>	

<p>6. Who did the work (Agency/consultants etc)? How many people were involved and what were their backgrounds (hydrology, hydrogeology, ecology, water quality etc).</p> <p><b>Scoping, Site Action Group (excluding Thames Water). Implementation, Atkins consultants Project Management, Environment Agency</b></p> <p><b>Background of people.</b></p> <p><b>Hydrology and hydrometry, hydrogeology and drilling supervision, ecology, project management.</b></p>
<p>7. Roughly how long did the study take?</p> <p>A few days      Months      <b>4</b> Years (finish March 2006)</p>
<p>8. What was the cost?</p> <p>&lt;£10k      £10-50k      &gt;£50k <b>well in excess of £50k</b></p>
<p>9. Did the assessment follow a standard procedure?</p> <p>Yes, please provide details</p> <p>No <b>Procedure followed was in line with EA HD guidance, guidance relates to policy rather than procedure, hence the need for a detailed scoping study.</b></p>
<p>10. Please provide a brief overview of what was done in carrying out the assessment.</p> <p><b>See attached newsletters.</b></p>
<p>11. Was the assessment purely desk based, or did it involve site investigation? <i>eg. Mainly desk based. A half-day visit was made to the site.</i></p> <p><b>See attached newsletters</b></p>
<p>12. What data were used, were there enough, were the data representative?</p> <p><b>See attached newsletters</b></p>
<p>13. What, if any, specific tools or models were used in the assessment? How useful were they?</p> <p><b>Groundwater Model (Mod Flow) Mike 11 (hydraulic modelling) Arcview Surfer</b></p>

14. Was the study successful? What problems arose? How confident were you in the results?

**4 year study is in its first year. Steep learning curve. Early signs show some successful outcomes in line with objectives. 4 month slippage in first year but spend on target.**

15. What gaps or needs did you identify? What would help you overcome the problems identified in Qu 14? Score 1-5 (1 =most important, 5 = least important)

**Gaps identified so far;**

**Need, Quantitative understanding of the hydrological preference of the snails 4.  
Will be overcome by hydro-ecological studies.**

**Need, good project management, installation is best undertaken in the  
spring/summer when ground is drier.**

**Will be overcome by planning installations and contingency in the spring/summer.  
Risk of meeting artesian conditions in chalk beside wetland need to be addressed  
5.**

**Need, good land owner liaison 3.**

**Will be overcome by intelligent project management.**

## THE KENNET AND LAMBOURN STUDY

This second newsletter provides an update on the progress of the Kennet and Lambourn wetlands project. The first newsletter was issued in August.

### Background

**The project aims to investigate the impacts of water abstraction on the Kennet and Lambourn valley wetlands.**

The Kennet and Lambourn valleys comprise one of the finest chalk stream systems in the UK. Many such systems have been affected by human activities, however, these valleys still retain most of the characteristic features of the chalk stream valley landscape. An important component of this landscape are the wetlands located along the river valleys. These are of high ecological value and support numerous rare and endangered flora and fauna.

The project is studying the hydrology of the wetlands in relation to the habitat of Desmoulin's Whorl Snail; a rare European mollusc. This study will provide valuable information that will be used to help conserve and protect these habitats.

### Progress to Date

**2002 snail surveys complete and a monitoring network is being installed.** The project has been divided into two phases. Phase 1 looks at the Lambourn valley wetlands at Bagnor, Boxford, Hunt's Green and Weston. Snail surveys have been completed for phase 1 and a hydrometric monitoring (water measurement) network is now being installed.

Phase 2 will look at the Kennet valley wetlands at Chilton Foliat, Eddington and Thatcham Reedbeds. This will begin in 2003.

December 2002 NEWSLETTER



## **Snail sampling in the Kennet and Lambourn valleys**

### **Desmoulin's Whorl Snail Surveys**

**Strong populations at Boxford and Weston but some decline recorded at other sites.** Initial surveys of snail distribution and abundance were carried out in July 2002. These were undertaken at four sites on the River Lambourn at Bagnor, Boxford, Hunt's Green and Weston. The technique for sampling Desmoulin's Whorl Snail involves shaking the reed and sedge vegetation over a plastic sheet and counting the dislodged snails.

The surveys showed differences between the four sites. Boxford and Weston have very high population densities of the snail and are thought to support an optimum habitat. Snail populations at Bagnor and Hunt's Green have declined since the previous surveys in the late 1990s. This could be due to a number of factors including changes in vegetation at the sites. These factors will be investigated during the project.

These initial surveys determined where the transect lines and grids were to be placed for the October 2002 snail sampling at the four sites. The results of these surveys will be reported in the next newsletter.

### **Hydrometric Installations**

**Water level monitoring points (boreholes) are currently being installed** in the peat, gravel and chalk layers of the four wetland sites. This will determine water movement in the wetlands and rivers. Boreholes are holes of various sizes and depths that are used to measure water levels below the ground surface. We are using new technology to install boreholes to minimise our environmental impact on the sites.

### **The Kennet Groundwater Model**

**A computer model of the Kennet and Lambourn catchments is almost complete.** We have used data from the last 30 years to develop a model which simulates groundwater levels and river flows. It looks at how they respond to factors such as rainfall, evaporation, abstractions from boreholes and discharges of effluent to rivers.

The model allows us to predict how abstractions may affect groundwater levels and river flows within the Kennet and Lambourn floodplains.

## The Kennet and Lambourn Study Website

**The website is now available on the Internet.** It contains information on the project, wetland habitats and Desmoulin's Whorl Snail. The site will provide regular updates on our progress and findings. The website can be found at:

<https://pronet.wsatkins.co.uk/KennetandLambournStage3>

A representative of the Atkins project team will be visiting interested community groups, including schools to promote the website and talk about the project in January.

## How Can You Get Involved?

Over the next few months we will install our hydrometric monitoring network. As data becomes available from this study, we can begin to investigate the factors which influence the distribution and abundance of Desmoulin's Whorl Snail.

Throughout the project, we hope to keep a number of community organisations informed on our progress through newsletters and the project website. If you have any queries or are interested in obtaining further information about the project please contact one of the people below.

### Contacts

Rory Callan – Environment Agency Manager

*Email:* [Rory.Callan@environment-agency.gov.uk](mailto:Rory.Callan@environment-agency.gov.uk)

*Tel:* (01491) 828 506

Paul Wright – Atkins Project Manager

*Email:* [Paul.wright@atkinsglobal.com](mailto:Paul.wright@atkinsglobal.com)

*Tel:* (07803) 237 751

Clare Spencer – Environmental Consultant

*Email :* [Clare.spencer@atkinsglobal.com](mailto:Clare.spencer@atkinsglobal.com)

*Tel :* (01865) 734603

## Wetland Impact Assessments

1. Wetland Name Lower Eastern Rother (Kent Area)	
2. Wetland type  Fen/reed bed Wet Grassland Bog/ mire (upland/lowland) Wet heath Wet woodland <input checked="" type="checkbox"/> Other (please specify) Lowland arable	3. Water source  <input checked="" type="checkbox"/> Surface-water fed Groundwater fed Combined surface-water/ groundwater fed
4. What question were you trying to answer? ie. the reason for carrying out the assessment, type of impact etc. To investigate whether improvements can be made to the flow data at Blackwall Bridge; To investigate whether the existing data at Scots Float can be used to derive a flow record; To review the pattern of water movement by considering pumped drainage and water level records; To investigate the need for additional flow measurement structures in the catchment.	
5. What was your conceptual understanding of the wetland system and how certain were you? Did you consider hydrology, hydrogeology, ecology?  The Lower Rother contains large areas of marshland with water levels controlled by sluices and with water pumped through ditch systems. A detailed knowledge of water movements was not known and it was a requirement of the project that the pattern of water movements should be investigated and the need for any additional flow measurements addressed. Ecology was not considered.	
6. Who did the work (Agency/consultants etc)? How many people were involved and what were their backgrounds (hydrology, hydrogeology, ecology, water quality etc).  JBA Consulting Engineers & Scientists	
7. Roughly how long did the study take?  A few days <input checked="" type="checkbox"/> Months    Years	
8. What was the cost?  <£10k <input checked="" type="checkbox"/> £10-50k    >£50k	



<p>9. Did the assessment follow a standard procedure?</p> <p>Yes, please provide details</p> <p><input checked="" type="checkbox"/> No</p>
<p>10. Please provide a brief overview of what was done in carrying out the assessment.</p> <ul style="list-style-type: none"> <li>• Analysis of hydrometric data</li> <li>• 2 water balance models of areas within the Lower Rother</li> <li>• HEC-RAS Flood Routing Model of the Lower Rother</li> </ul>
<p>11. Was the assessment purely desk based, or did it involve site investigation?</p> <p>Mainly a desk study with some site visits.</p>
<p>12. What data were used, were there enough, were the data representative?</p> <p>All available hydrometric data, including pumping station records, were used. They were generally representative but there are some major tributaries with no flow records.</p>
<p>13. What, if any, specific tools or models were used in the assessment? How useful were they?</p> <p>Excel spreadsheet water balance model: uncalibrated but provides some understanding of the water movements through the catchment.</p> <p>HEC-RAS (v.3) was used, however there were instability problems associated with the operation of the fish pass in the tidal sluice at Scots Float. The model is limited to the period of available pumping data .</p>
<p>14. Was the study successful? What problems arose? How confident were you in the results?</p> <p>1 &amp; 2 – No flow data could be derived from these two important sites in the Lower Rother. This means we have very limited historical data, other than the marsh pumping stations (there are 20)</p> <p>3. There is better understanding of the water movement within the marsh but its highly managed nature means that resource and impact assessment is still not straightforward. This has implications not only for the Rother Marshes but also the availability of water from the Royal Military Canal, Romney Marsh and Walland Marsh.</p> <p>4. Flow monitoring in such large, slow flowing channels remains a problem.</p>
<p>15. What gaps or needs did you identify? What would help you overcome the problems identified in Qu 14? Score 1-5 (1 =most important, 5 = least important)</p> <p>Modelling managed systems: 1</p> <p>Hydrometry in wetland and low-lying areas: 1</p>

## Wetland Impact Assessments

1. Wetland Name <b>Marizion Marsh SSSI/SPA, Cornwall</b>	
2. Wetland type  <input checked="" type="checkbox"/> Fen/reed bed <input type="checkbox"/> Wet Grassland <input type="checkbox"/> Bog/ mire (upland/lowland) <input type="checkbox"/> Wet heath <input type="checkbox"/> Wet woodland <input type="checkbox"/> Other (please specify)	3. Water source  <input type="checkbox"/> Surface-water fed <input type="checkbox"/> Groundwater fed <input checked="" type="checkbox"/> Combined surface-water/ groundwater fed  <i>Assumed (its part of the research objectives)</i>
4. What question were you trying to answer? ie. the reason for carrying out the assessment, type of impact etc.  <b>Better understanding of site's water balance to enable various EA consents to be reviewed in terms of water quantity and quality (loadings). To assess impacts of proposed RSPB management alterations.</b>	
5. What was your conceptual understanding of the wetland system and how certain were you? Did you consider hydrology, hydrogeology, ecology?  <b>It was assumed that the various in flowing water courses provided varying flow/loading to the site - this needed quantifying. Groundwater regime believed to be .important here, also needed quantifying</b>	
6. Who did the work (Agency/consultants etc)? How many people were involved and what were their backgrounds (hydrology, hydrogeology, ecology, water quality etc).  <b>EA scope (Conservation and Hydrology). Consultants carried out assessment, EA reviewed. All stages in collaboration with EN and RSPB.</b>	
7. Roughly how long did the study take? <input type="checkbox"/> A few days <input checked="" type="checkbox"/> Months <input type="checkbox"/> Years <b>(finish March 2006)</b>	
8. What was the cost? <input type="checkbox"/> <£10k <input checked="" type="checkbox"/> £10-50k <input type="checkbox"/> >£50k <b>Phase 1 6k Phase 2 20k</b>	
9. Did the assessment follow a standard procedure?	

<p>X Yes, please provide details    <b>Use of data esp, abstraction licences &amp; flow/rainfall plus RSPB site monitoring data</b></p> <p>No</p>
<p>10. Please provide a brief overview of what was done in carrying out the assessment.</p> <p><b>Rainfall data, abstraction licence limits &amp; returns &amp; flow data from adjacent catchment used to establish relative <math>Q_{95}</math> in each water course to enable each licence impact to be assessed. Geology map used to assess aquifer characteristics.</b></p>
<p>11. Was the assessment purely desk based, or did it involve site investigation?</p> <p><b>Mainly desk based, one day site visit</b></p>
<p>12. What data were used, were there enough, were the data representative?</p> <p><b>See 10 above for data used. There were/are significant gaps in the data, hence the need for Phase 2, which seeks to address this.</b></p>
<p>13. What, if any, specific tools or models were used in the assessment? How useful were they?</p> <p><b>Contact me if you want this info, <a href="mailto:martin.mule@en">martin.mule@en</a></b></p>
<p>14. Was the study successful? What problems arose? How confident were you in the results?</p> <p><b>Assessment indicated the relevant EA licences are sustainable, but also indicated a need for more research (eg. boreholes) to confidently enable proposed management changes to be implemented.</b></p>
<p>15. What gaps or needs did you identify? What would help you overcome the problems identified in Qu 14? Score 1-5 (1 =most important, 5 = least important)</p> <p><b>Always need more real data, especially of a reasonable time frame - had to model flows from the adjacent catchment</b></p>

## Wetland Impact Assessments

1. Wetland Name Newbald Becksies	
2. Wetland type  Fen/reed bed <b>X</b> Wet Grassland Bog/ mire (upland/lowland) Wet heath Wet woodland Other (please specify)	3. Water source  Surface-water fed <b>X</b> Groundwater fed - <b>springs</b> Combined surface-water/ groundwater fed
4. What question were you trying to answer? ie. the reason for carrying out the assessment, type of impact etc.  <b>Impact of existing water company groundwater abstraction close to site. If adverse impact need to vary licence to ensure sustainable abstraction regime.</b>	
5. What was your conceptual understanding of the wetland system and how certain were you? Did you consider hydrology, hydrogeology, ecology?  <b>Assume hydrological contact because site was a mosaic of flush &amp; wetland communities dependent on chalk springs within the site. Abstractions is from chalk 2-300m up valley.</b>	
6. Who did the work (Agency/consultants etc)? How many people were involved and what were their backgrounds (hydrology, hydrogeology, ecology, water quality etc).  <b>Agency planning &amp; carrying out baseline monitoring - hydrogeologist, hydrologist and Biodiversity input. Also EN (site is SSSI) and Yorkshire Wildlife Trust (managers of site) Vegetation survey to be carried out by external contract. Water company to plan &amp; carry out pump tests &amp; modelling of impacts.</b>	
7. Roughly how long did the study take? <b>anticipated to be Years</b>	
8. What was the cost? <b>anticipated to be &lt;£10k to Agency, cost to Water company not known (planning &amp; carrying out pump testing &amp; interpretation of results, modelling impacts</b>	
9. Did the assessment follow a standard procedure? <b>No</b>	

10. Please provide a brief overview of what was done in carrying out the assessment.

**Install temporary flow measurement at stream leaving from site and near upper end of site on flow from some of the springs. Aim to tie in data with flows measured at existing gauging station downstream. Install piezometers at two points along length of site, in line away from water company boreholes.**

**Detailed methods of analysis still to be determined. Comparison of abstraction , groundwater, rainfall and surface water flows to determine links (and scale of links) between abstraction and hydrology of site. Considering using simple model to calculate water levels at various points around the site as this will affect vegetation which is key feature for which the site is designated.**

**Need to separate natural variations from abstraction-influenced changes. Plan to seek nearby observation borehole in similar situation which is not influenced by abstraction to compare trends in groundwater levels with data taken from site.**

**Intend to identify key species/communities for which the site is important and carry out literature review of water level requirements and tolerance to drying. Then could relate this to the consequences of different abstraction regimes.**

**As actual abstraction is much less than licensed, need water company to carry out pump testing to assess the effects of different abstraction regimes on the site so that the licence can be modified if this is necessary to protect the site.**

11. Was the assessment purely desk based, or did it involve site investigation?

**will involve site investigation**

12. What data were used, were there enough, were the data representative?

**not able to answer yet beyond info given in 10 above**

13. What, if any, specific tools or models were used in the assessment? How useful were they?

**not able to answer yet, beyond information given in 10 above. Considering HECRAS?**

14. Was the study successful? What problems arose? How confident were you in the results?

**Not able to answer yet. Assessment only just starting.**

15. What gaps or needs did you identify? What would help you overcome the problems identified in Qu 14? Score 1-5 (1 =most important, 5 = least important)

**Unsure what standard procedures can be used for analysis of data to identify cause & effect and determine max sustainable abstraction rates in this type of situation. (need to end up with a robust assessment of the degree to which abstraction affects groundwater levels/sw flows beyond natural variation). So this relates to 1 & 3 above. Data collection programme hasn't presented a problem, but would have more confidence in it if had a clearer idea of the methods to be used for assessment at the end - design of data collection programme should follow from plan of how eventual analysis will be carried out**

## Wetland Impact Assessments

1. Wetland Name North Meadow and Clattinger Farm	
2. Wetland type  Fen/reed bed <b>X</b> Wet Grassland Bog/ mire (upland/lowland) Wet heath Wet woodland Other (please specify)	3. Water source  Surface-water fed Groundwater fed <b>X</b> Combined surface-water/ groundwater fed
4. What question were you trying to answer? ie. the reason for carrying out the assessment, type of impact etc.  <b>The work on this site is a Stage 3 Habitats Directive Appropriate Assessment to investigate whether there is <i>significant</i> impact of 3 existing Public Water Supply Licences on the MG4 grassland for which the sites have been designated.</b>	
5. What was your conceptual understanding of the wetland system and how certain were you? Did you consider hydrology, hydrogeology, ecology?  <b>The conceptual understanding of the wetland system is very difficult due to the complex nature of the hydrogeology. The path way for impact between the abstraction from the Oolitic Limestone aquifer and the wetland sites is via the main surface water features - the River Thames, the River Churn, the Swill Brook and the Flagham Brook. This is because there is no direct continuity between the wetland sites and the aquifers from which the abstractions are made, therefore abstraction from the aquifer can only impact by effecting the headwaters of the rivers where the aquifer outcrops. This is further complicated by the extensive gravel extraction in the area, which has resulted in a series of large lakes with various level control structures and some of which are still being quarried. Therefore, there are obviously a lot of influences on the hydrology of the sites which might effect their status.</b>	
6. Who did the work (Agency/consultants etc)? How many people were involved and what were their backgrounds (hydrology, hydrogeology, ecology, water quality etc).  <b>The work is presently being undertaken by consultants from Atkins in consultation with the EA, EN and the local Wildlife Trust who own and manage part of the site. The following people are involved: Don Ross - project manager/hydrogeologist (Atkins)</b>	

<p>Liz Hammock - Ecologist (Atkins)  David Gasca - Hydrogeologist (Atkins)  Lesley McWilliams - Hydrogeologist (Atkins)  Tim Frayling - EN; Paul Hill - WWT  Me - Hydrologist (EA); Vin Robinson - Hydrogeologist (EA)</p>
<p>7. Roughly how long did the study take?  <b>The study is still underway - at present the work has only been planned for a year but is likely to take several as the deadline for the completion of the project is March 2006.</b></p>
<p>8. What was the cost?  &lt;£10k      £10-50k    <b>X</b>    &gt;£50k</p>
<p>9. Did the assessment follow a standard procedure?  Yes, please provide details  ● No</p>
<p>10. Please provide a brief overview of what was done in carrying out the assessment.</p> <p><b>All available data is being collated and an additional monitoring network has been installed at Clattinger Farm as water levels at this site have not really been recorded. Considerable research is being conducted at North Meadow where a hydroecological model has been developed relating water levels to habitat - specifically MG4 grassland.</b></p> <p><b>It is hoped to develop a water level balance for the gravel aquifer and to revisit previous work on the Oolitic aquifers. This will be done by looking at available hydrological and meteorological data.</b></p> <p><b>It is hoped that the hydroecological model developed at North Meadow can be revisited using different abstraction scenarios and equally that there may be some way of transferring this methodology to the Clattinger Farm Site.</b></p> <p><b>At present only the first year of the investigation has been planned.</b></p>
<p>11. Was the assessment purely desk based, or did it involve site investigation?</p> <p><b>The assessment will be a combination of desk-based work looking at historical flow and level data and pump test results and also field based making further spot flow recordings and downloading data from water level loggers. A soil survey will also be undertaken.</b></p>
<p>12. What data were used, were there enough, were the data representative?</p> <p><b>There is reasonable amount of data available however further data are being</b></p>



collected especially at the Clattinger Farm site where there is little historical data available. Hopefully this will mean that the information is representative, especially if the dry weather continues.

13. What, if any, specific tools or models were used in the assessment? How useful were they?

It is intended that Dr David Gowings SEV hydro-ecological will be used in the assessment - however it is as yet unclear how useful this will be in ultimately drawing a conclusion about impact as it is dependent on expert hydrogeological opinion for its inputs.

No regional groundwater model is being developed as this has been unsuccessfully attempted before due to the complex nature of the hydrogeology.

14. Was the study successful? What problems arose? How confident were you in the results?

The study is yet to be concluded, however the main problem at present is the complexity of the hydrogeology in the area, which makes understanding or determining impact very difficult.

15. What gaps or needs did you identify? What would help you overcome the problems identified in Qu 14? Score 1-5 (1 =most important, 5 = least important)

If there was some form of standard methodology to follow for investigations such as these it may make it easier - however, in this instance I would think it was very difficult to use a generic approach given the specific problems highlighted here. Some guidance as to possible approaches and the extent to which these should be taken, I think would be very useful.

## Wetland Impact Assessments

1. Wetland Name Oakmere	
2. Wetland type	3. Water source
Fen/reed bed Wet Grassland Bog/ mire (upland/lowland) Wet heath Wet woodland <input checked="" type="checkbox"/> Other (please specify) - lowland mere	Surface-water fed <input checked="" type="checkbox"/> Groundwater fed Combined surface-water/ groundwater fed
4. What question were you trying to answer? ie. the reason for carrying out the assessment, type of impact etc  <b>Whether Oakmere is impacted by pws groundwater abstraction from adjacent sandston, or other activities e.g. quarrying of the sand sheet which underlies Oakmere</b>  <b>Q1 - is there any hydraulic continuity between water body of Oakmere and underlying sand?</b> <b>Q2 - is there Hydraulic continuity between sand sheet and sandstone aquifer - see below</b> <b>Q3 - If pws abstraction stopped would this increase feed in to Oakmere?</b> <b>Q4 - Does sand extraction all around Oakmere affect the hydraulic gradient and increase evaporation such that it would potentially depress gwl below Oakmere and hence increase leakage Note:WL in Oakmere is slightly higher than surrounding groundwater in sand.</b>	
5. What was your conceptual understanding of the wetland system and how certain were you? Did you consider hydrology, hydrogeology, ecology?  <b>Oakmere at top of a groundwater mound, peat lined but sitting on sand sheet., over mudstones. Mudstones in faulted contact with sandstone, used for pws. Groundwater levels in sandstone depressed well below ground level, due to historic long term pws abstraction. Some 'cascading' of groundwater in to sandstone from sand.'</b>  <b>Oakmere is rainfall feed, with no surrounding surface water catchments, but dependant on maintaining groundwater levels within sand so as not to increase natural head gradient and hence leakage.</b>	

<p>6. Who did the work (Agency/consultants etc)? How many people were involved and what were their backgrounds (hydrology, hydrogeology, ecology, water quality etc).</p> <p><b>Construction of piezos around site contract managed by Agency - experienced hydrogeologist</b>  <b>Investigative modelling of sandstone aquifer done in-house by hydrogeologist /modeller</b>  <b>Data collection, collation and conceptual modelling and water balance by WMC.Ltd - Hydrogeological focus</b></p>
<p>7. Roughly how long did the study take?</p> <p>A few days    <input checked="" type="checkbox"/> Months - for desk study analysis    <input checked="" type="checkbox"/> Years - for monitoring - gw/sw</p>
<p>8. What was the cost?</p> <p><input type="checkbox"/> &lt;£10k    <input checked="" type="checkbox"/> £10-50k    <input type="checkbox"/> &gt;£50k</p>
<p>9. Did the assessment follow a standard procedure?</p> <p>Yes, please provide details</p> <p><input checked="" type="checkbox"/> <b>No - designed to suit situation and the specific questions</b></p>
<p>10. Please provide a brief overview of what was done in carrying out the assessment.</p> <p><b>Desk study - GWL and rainfall data collection , borehole records from quarrying companies + their monitoring data to produce long term hydrographs</b>  <b>Water Balances,</b></p>
<p>11. Was the assessment purely desk based, or did it involve site investigation?</p> <p><b>Piezos drilled around site and loggers installed</b>  <b>Deep bh drilled in to sandstone (part of another project)</b>  <b>Site area visit, instigated programme of spot gaugings around sand sheet to aid in water balance</b>  <b>Data logger installed on Oakmere</b></p>
<p>12. What data were used, were there enough, were the data representative?</p> <p><b>GWL records from old mineral monitoring boreholes (from 1990, but incomplete in recent years + more recent records from data loggers on new piezos from 2001.</b>  <b>Historic long-term hydrographs for sandstone aquifers</b></p>
<p>13. What, if any, specific tools or models were used in the assessment? How useful were they?</p> <p><b>No specific tool used for looking at sand sheet- Vistas used for investigative model of sandstone aquifer</b></p>

14. Was the study successful? What problems arose? How confident were you in the results?

**Successful - satisfied from the conceptual understanding that the pws sandstone abstractions do not affect Oakmere. Potentially at risk from quarrying, but Mineral Planning Authority is the Competent Authority to assess significance, so advised EN and MPA to investigate further the significance of these activities.**

15. What gaps or needs did you identify? What would help you overcome the problems identified in Qu 14? Score 1-5 (1 =most important, 5 = least important)

**Linking/correlating interaction/interdependance of Ecology/Oakmere levels/GWLs - since not Agency remit no further work rests on Agency. If it were then key issues would be:**

**Vertical leakage through an unknown peat base to lake (properties, head dependence (2)**

**Significance of surrounding scrub vegetation i.e transpiration loss as vegetation matures c.f overall water balance (2).**

## Wetland Impact Assessments

1. Wetland Name		Pevensey Levels Ramsar, component SSSI's	
2. Wetland type		3. Water source	
Fen/reed bed <input checked="" type="checkbox"/> Wet Grassland Bog/ mire (upland/lowland) Wet heath Wet woodland Other (please specify)		<input checked="" type="checkbox"/> Surface-water fed Groundwater fed Combined surface-water/ groundwater fed	
<p>4. What question were you trying to answer? ie. the reason for carrying out the assessment, type of impact etc.</p> <p>To determine whether or not the surface water abstraction and groundwater augmentation scheme within the Wallers haven sub-catchment of the Pevensey Levels, is having a significant impact on the water balance and water levels.</p> <p>This assessment has been divided into several phases:          Phase 1 considers the abstraction of groundwater in the upper catchment (used to augment low river flow and sustain downstream river abstraction) and the likely impact of the augmentation scheme on the overall movements of water flowing through the system. Phase 2 has just been completed (draft report stage) to evaluate the surface water abstraction relative to the requirements of the wetland system.</p>			
<p>5. What was your conceptual understanding of the wetland system and how certain were you? Did you consider hydrology, hydrogeology, ecology?</p> <p>The ecological value of the system has declined in recent years, thought likely due to the change in water management; a scheme to maintain relatively high water levels in the ditches has succeeded in improving the ecological value of the ditches, but has had limited success in adjacent fields. It is suggested that the wetland ecology would be enhanced by regular winter flooding of whole fields, and by maintaining higher water levels during the summer months.</p> <p>The Wallers Haven channel is a major water source for sustaining the wetland system. The hydrology and hydrogeology of the eastern catchment required a detailed investigation to quantify the likely impact of the water company scheme on surface run-off required to allow inundation and high water levels within the system.</p>			

<p><b>6. Who did the work (Agency/consultants etc)?</b> How many people were involved and what were their backgrounds (hydrology, hydrogeology, ecology, water quality etc).</p> <p><b>Phase 1: Consultants (Water Resources Associates) on behalf of South East Water plc (AMP3 driven investigation):</b> various people (hydrologist, hydrogeologist, GIS specialist etc.) Subsequent consultation/ verification with EA hydrologist and ecologist, external consultation with English Nature (EN).</p> <p><b>Phase 2: Consultants (WS Atkins) on behalf of South East Water plc (AMP3 driven investigation):</b> various people (hydrologist, wetland hydrologist, ecologist, GIS specialist). EA/ EN consultation.</p>
<p><b>7. Roughly how long did the study take?</b></p> <p>A few days    <input checked="" type="checkbox"/> Months    Years</p>
<p><b>8. What was the cost?</b></p> <p>&lt;£10k    <input checked="" type="checkbox"/> £10-50k    &gt;£50k</p>
<p><b>9. Did the assessment follow a standard procedure?</b></p> <p>Yes, please provide details</p> <p><input checked="" type="checkbox"/> No</p>
<p><b>10. Please provide a brief overview of what was done in carrying out the assessment.</b></p> <p><b>Phase 1: Existing data and information (of upper catchment) were collated and reviewed to produce a desk-top hydrogeological understanding of catchment, and to enable the development of (i) a Hysim model for run-off predictions and (ii) a complementary water balance model for understanding groundwater flow in the region. Subsequently a rainfall-runoff model was developed using Hysim and available data (hydrometric, meteorological etc.) to simulate both natural and artificially influenced discharge regimes. The model was then interpreted to predict the likely impact of abstraction, in the upper catchment, on the water levels within the Pevensey Levels.</b></p> <p><b>Phase 2 (draft report received 23/6/03): water balance model of the lower catchment, to compare availability of water with full authorised and historic actual abstractions, against the baseline of no abstraction.</b></p>
<p><b>11. Was the assessment purely desk based, or did it involve site investigation?</b></p> <p><b>Phase 1: Mostly desk based. Short reconnaissance of the upstream catchment, to identify location of all existing boreholes. 1-day field survey of springs in upper catchment, to gauge flow. 1-day field visits to assess various water management structures.</b></p> <p><b>Phase 2: Literature review, stakeholder consultation, field work and water balance modelling.</b></p>

12. What data were used, were there enough, were the data representative?

Various short/ long term pumping test data;  
Meteorological data for run-off predictions (various representative years);  
Local rainfall gauge data over period 1920 - 1998;  
River discharge records (some 50-year 1950-2000);  
EA/ water company abstraction data (actual and licensed);  
MRF data.

One data gap was that there were no long-term hydrographs were available, from observation wells sited in the main aquifer; this influenced the approach that was used for the water balance model.

13. What, if any, specific tools or models were used in the assessment? How useful were they?

- (i) HYSIM modelling for run-off modelling, and rainfall-runoff simulation
- (ii) Water Balance modelling - a new model, used here as insufficient groundwater level data were available for traditional water balance calculations.
- (iii) Water balance Model (WHAAM) to predict the impacts of the surface water abstraction on water levels in the Wallers haven.

These (complementary) modelling components were all fundamental to answering the key question of the study.

14. Was the study successful? What problems arose? How confident were you in the results?

Phase 1: The study was able to conclude with confidence, following internal/ external consultation, that the groundwater augmentation is small in relation to other groundwater flow components.

Phase 2: Report currently being evaluated: initial conclusions show that the abstraction currently has an impact on the wetland system; impacts could possibly be reduced by repairing sluice gate leaks and improved management of the feed system.

15. What gaps or needs did you identify? What would help you overcome the problems identified in Qu 14? Score 1-5 (1 = most important, 5 = least important)

Lack of hydrological data (levels, flows etc) to maximise the reliability of the modelling on which the assessment has primarily been based.

Jo Simmons  
23/6/03

## Wetland Impact Assessments

1. Wetland Name Pulfin Bog	
2. Wetland type  Fen/reed bed Wet Grassland <input checked="" type="checkbox"/> Bog/ mire (upland/lowland) Wet heath Wet woodland Other (please specify)	3. Water source  Surface-water fed Groundwater fed <input checked="" type="checkbox"/> Combined surface-water/ groundwater fed
4. What question were you trying to answer? ie. the reason for carrying out the assessment, type of impact etc.  <b>Degrading habitat post mid 90's drought - Yorkshire Wildlife Trust looking into means to re-wet the site but lacking any real knowledge on what controlled water levels.</b>	
5. What was your conceptual understanding of the wetland system and how certain were you?  <b>Originally assumed surface water fed (entirely surrounded by water, understood to be underlain by significant depth of clay over chalk). Local assumption was that it was groundwater fed - but this purely based on knowledge that this was a 'chalk' area.</b>	
6. Who did the work (Agency/consultants etc)? How many people were involved and what were their backgrounds (hydrology, hydrogeology, ecology, water quality etc).  <b>Internal Agency assessment (self!) One or two others involved in project from Ec and Rec perspective - but not in the conceptualisation.</b>	
7. Roughly how long did the study take? A few days      Months <b>2</b> Years	
8. What was the cost? <input checked="" type="checkbox"/> <£10k      £10-50k      >£50k	
9. Did the assessment follow a standard procedure? Yes, please provide details <input checked="" type="checkbox"/> No	



<p>10. Please provide a brief overview of what was done in carrying out the assessment.</p> <p><b>Mainly involved analysis of EA and YWT monitoring data to determine relationships between bog, river, adjacent borrow pit and groundwater.</b></p>
<p>11. Was the assessment purely desk based, or did it involve site investigation?</p> <p><b>Mainly desk based - one visit to the site.</b></p>
<p>12. What data were used, were there enough, were the data representative?</p> <p><b>Intermittent level data from YWT - sporadic as site inaccessible in wet conditions. Also habit of using trees as datum points! Some monitoring points changed and were not always monitored for long. EA data more reliable and consistent. Data marginal but just adequate.</b></p>
<p>13. What, if any, specific tools or models were used in the assessment? How useful were they?</p> <p><b>No specific tools other than spreadsheets</b></p>
<p>14. Was the study successful? What problems arose? How confident were you in the results?</p> <p><b>Study reasonably successful. Enough evidence to suggest that a proposed method of remediating the problem would be unsuccessful (this being to re-open an old surface water channel into the bog). Indicated that the flora and fauna depended on pools within the bog that were supplied by groundwater. The past few wet years have seen the site improve so the problem sorted itself out to some extent.</b></p>
<p>15. What gaps or needs did you identify? What would help you overcome the problems identified in Qu 14?</p> <p><b>The main problem though was conceptualising. Local opinion was that the bog was fed by chalk - due to not understanding finer points of geology. My original opinion was that it wasn't chalk fed due to published data about chalk. Finally turned out to be chalk after all due to mis-interpretation in Geol maps of depth of chalk!</b></p>

## Wetland Impact Assessments

1. Wetland Name Shirley Pool SSSI	
2. Wetland type  <input checked="" type="checkbox"/> Fen/reed bed <input checked="" type="checkbox"/> Wet Grassland Bog/ mire (upland/lowland) Wet heath Wet woodland Other (please specify)	3. Water source  Surface-water fed Groundwater fed <input checked="" type="checkbox"/> Combined surface-water/ groundwater fed
4. What question were you trying to answer? ie. the reason for carrying out the assessment, type of impact etc..  <b>Drying out of pool and adjacent boggy land (with bronze age archaeological site)</b>	
5. What was your conceptual understanding of the wetland system and how certain were you? Did you consider hydrology, hydrogeology, ecology?.  <b>Pool and bog in continuity with drift/Sherwood Sandstone. Not much data though. Degraded by agricultural drainage.</b>	
6. Who did the work (Agency/consultants etc)? How many people were involved and what were their backgrounds (hydrology, hydrogeology, ecology, water quality etc).  <b>Agency</b>	
7. Roughly how long did the study take? <input checked="" type="checkbox"/> A few days      Months      Years	
8. What was the cost? <£10k      £10-50k      >£50k	
9. Did the assessment follow a standard procedure? Yes, please provide details <input checked="" type="checkbox"/> No	
10. Please provide a brief overview of what was done in carrying out the assessment.  <b>Merely theoretical assessment of situation plus advice on mitigation.</b>	

<p>11. Was the assessment purely desk based, or did it involve site investigation?</p> <p><b>One site visit</b></p>
<p>12. What data were used, were there enough, were the data representative?</p> <p><b>Some piezo data available - recommended more for later installation</b></p>
<p>13. What, if any, specific tools or models were used in the assessment? How useful were they?</p>
<p>14. Was the study successful? What problems arose? How confident were you in the results?</p> <p><b>Enough understanding to dissuade EN from pursuing misguided application to replenish from Magnesian Limestone Aquifer.</b></p>
<p>15. What gaps or needs did you identify? What would help you overcome the problems identified in Qu 14? Score 1-5 (1 =most important, 5 = least important)</p>

## Wetland Impact Assessments

<p>1. Wetland Name <b>South Pennine Moors</b></p>	
<p>2. Wetland type</p> <p>Fen/reed bed</p> <p>Wet Grassland</p> <p><input checked="" type="checkbox"/> Bog/ mire (upland/lowland)</p> <p><input checked="" type="checkbox"/> Wet heath</p> <p>Wet woodland</p> <p>Other (please specify)</p>	<p>3. Water source</p> <p>mostly rainwater/shallow gw fed</p>
<p>4. What question were you trying to answer? ie. the reason for carrying out the assessment, type of impact etc..</p> <p><b>Impact of a number of existing abstractions, at different locations, on designated features of the Habitats Directive site. The features classified as sensitive to abstraction were blanket bog and wet heath (including transition mires)</b></p>	
<p>5. What was your conceptual understanding of the wetland system and how certain were you? Did you consider hydrology, hydrogeology, ecology?</p> <p><b>Established conceptual understanding through site visits.</b></p> <p><b>Example: borehole adjacent to site, at lowest point of large 'crater' shaped area. Not used since last drought but required by water company as emergency source. Had some geological knowledge of area which suggested impermeable layers between features and the borehole. Rest water level in borehole substantially below ground and all of surrounding designated area considerably higher than borehole so there appeared to be no hydraulic continuity between the groundwater from which the abstraction was taking place and the water supplying the features. The closest parts of the site were wet heath, and further away, on higher plateau surrounding this, was blanket bog. Effect on blanket bog was ruled out due to distance/difference in elevation and additionally the assumption that the bog had developed as a result of rainwater retained by vegetation &amp; soil on underlying impermeable layers.</b></p> <p><b>Other boreholes: desk assessment carried out by hydrogeologist to produce theoretical drawdown. All of these were very small abstractions (generally around or less than 20m<sup>3</sup>/day) and drawdown was concluded not to have a significant effect on the site.</b></p>	

<p><b>Springs: mainly feeding wet flushes in areas of often degraded wet heath. Generally an impact was ruled out based on either the length of time over which the abstractions had taken place (at least 40 years, during which time the vegetation would have adapted) and the presence of some leakage from spring chambers, and wet flushes still existent downstream of the springs. None of the springs were in areas of blanket bog.</b></p>
<p><b>6. Who did the work (Agency/consultants etc)? How many people were involved and what were their backgrounds (hydrology, hydrogeology, ecology, water quality etc).</b></p> <p><b>Agency water resources in consultation with EN. Involved enforcement officers for licences, For the borehole with large licensed quantity also involved Biodiversity and Hydrogeologist who came on site visit and gave advice.</b></p>
<p><b>7. Roughly how long did the study take?</b></p> <p><b>A few days work in total      A few months to organise &amp; complete</b></p>
<p><b>8. What was the cost?</b></p> <p><b>negligible - time and minimal resources only      &lt;£10k</b></p>
<p><b>9. Did the assessment follow a standard procedure?</b></p> <p><b>Only in so far as it followed best practice from other Regions/Areas in approaching similar problems by a site visit.</b></p>
<p><b>10. Please provide a brief overview of what was done in carrying out the assessment.</b></p> <p><b>Assessed theoretical drawdown of all abstractions. One abstraction had an extremely large area of drawdown (several km<sup>2</sup>). Others very small - insignificant.</b></p> <p><b>Initially checked locations of springs and available data on abstraction rates and licensed quantities. Discussed local knowledge held by e.g. Agency enforcement officer and EN Conservation Officer. Established conceptual understanding of the types of impacts being looked for and the mechanisms by which these could take place as a result of different kinds of abstraction.</b></p> <p><b>Looked at aerial photographs and nvc information/EN Phase 1 maps (none of this information was particularly useful - still needed site visits).</b></p> <p><b>Wrote site visit report with photographs and maps of site. This will form basis of appropriate assessment under HD.</b></p>
<p><b>11. Was the assessment purely desk based, or did it involve site investigation?</b></p> <p><b>For small borehole abstractions was desk based. For springs and large borehole needed to visit site (approx ½ day per licence).</b></p>

12. What data were used, were there enough, were the data representative?

**No data except standard transmissivities etc. to calculate theoretical drawdown at boreholes.**

13. What, if any, specific tools or models were used in the assessment? How useful were they?

**None**

14. Was the study successful? What problems arose? How confident were you in the results?

**Yes, was successful. Further monitoring of groundwater levels at the large borehole has been recommended to confirm that the observed rest water level during the site visit was typical (i.e. to confirm that the groundwater would not at other times be in continuity with the designated features of the site)**

15. What gaps or needs did you identify? What would help you overcome the problems identified in Qu 14? Score 1-5 (1 =most important, 5 = least important)

**A standard procedure for this kind of assessment would be useful in the future, particularly in case there were any new applications for abstraction licences.**

## Wetland Impact Assessments

1. Wetland Name <b>Stour Marshes (Kent Area)</b>	
2. Wetland type  Fen/reed bed Wet Grassland Bog/ mire (upland/lowland) Wet heath Wet woodland Other (please specify) Grazing Marsh & low-lying arable	3. Water source  Surface-water fed Groundwater fed <input checked="" type="checkbox"/> Combined surface-water/ groundwater fed
4. What question were you trying to answer? ie. the reason for carrying out the assessment, type of impact etc.  Water availability for Stour CAMS	
5. What was your conceptual understanding of the wetland system and how certain were you? Did you consider hydrology, hydrogeology and ecology?  Good qualitative understanding but poor quantitative understanding: lack of data. Springs feed a marsh system that may or may not be in hydrological continuity with the underlying aquifer. The system is then drained through the sea wall either through tidal flaps or pumps directly into the sea at Reculver or into the Stour. There is a high degree of level management almost exclusively for flood defence management, though the Agency operates a pumping station to transfer water from the Stour into the Chislet Marshes, to the west of Thanet. Hydro-ecological understanding is not that good.	
6. Who did the work (Agency/consultants etc)? How many people were involved and what were their backgrounds  Internal Agency assessment by a Water Resources Hydrologist.	
7. Roughly how long did the study take? A few days <input checked="" type="checkbox"/> Months    Years	
8. What was the cost? <input checked="" type="checkbox"/> <£10k    £10-50k    >£50k	
9. Did the assessment follow a standard procedure? Yes, please provide details <input checked="" type="checkbox"/> No	

<p>10. Please provide a brief overview of what was done in carrying out the assessment.</p> <p>A water balance was estimated with the following components: rainfall, inflow from tributaries, sluice feeds, water pumped in, field evaporation, ditch evaporation and abstractions. Discharges were considered to be insignificant.</p>
<p>11. Was the assessment purely desk based, or did it involve site investigation?</p> <p>Mainly desk based, with site visits with local flood defence and IDB officers.</p>
<p>12. What data were used, were there enough, were the data representative?</p> <p>Standard hydrometric data. There was not enough data, especially continuous flow and level measurement and what data was available was only representative of a small part of the site. Groundwater levels were analysed by no significant trends were found and there was a lot of variability.</p>
<p>13. What, if any, specific tools or models were used in the assessment? How useful were they?</p> <p>None.</p>
<p>14. Was the study successful? What problems arose? How confident were you in the results?</p> <p>It was successful in being able to present a water status that could be included in the CAMS, however the large uncertainty makes it of very limited use for implementing abstraction policy in the marsh.</p>
<p>15. What gaps or needs did you identify? What would help you overcome the problems identified in Qu 14? Score 1-5 (1 =most important, 5 = least important)</p> <p>Continuous level measurements: 1  Continuous flow measurements: 1  Measurements of what leaves the marsh system, e.g. through tidal flaps.: 1  A standard RAM-like methodology: 2</p>



## Wetland Impact Assessments

1. Wetland Name <b>Swale Marshes - Low Halstow to Whitstable</b>	
2. Wetland type  Fen/reed bed Wet Grassland Bog/ mire (upland/lowland) Wet heath Wet woodland <input checked="" type="checkbox"/> Other (please specify) Grazing Marsh & saline mudflats	3. Water source  Surface-water fed Groundwater fed <input checked="" type="checkbox"/> Combined surface-water/ groundwater fed
4. What question were you trying to answer? ie. the reason for carrying out the assessment, type of impact etc.  <b>(1) Water availability for North Kent CAMS</b> <b>(2) Appropriate Assessment for Habitats Directive.</b>	
5. What was your conceptual understanding of the wetland system and how certain were you? Did you consider hydrology, hydrogeology, ecology?  <b>Good qualitative understanding but poor quantitative understanding: lack of data. Springs feed a marsh system that may or may not be in hydrological continuity with the underlying aquifer. The system is then drained through the sea wall either through tidal flaps or pumps. There is a high degree of level management almost exclusively for flood defence management, though some areas are managed for ESA and other environmental schemes. Hydro-ecological understanding is not that good.</b>	
6. Who did the work (Agency/consultants etc)? How many people were involved and what were their backgrounds (hydrology, hydrogeology, ecology, water quality etc).  <b>Internal Agency hydrogeologist with a background in geology.</b>	
7. Roughly how long did the study take? A few days <input checked="" type="checkbox"/> Months    Years	
8. What was the cost? <input checked="" type="checkbox"/> <£10k    £10-50k    >£50k	

<p>9. Did the assessment follow a standard procedure?</p> <p>Yes, please provide details</p> <p><b>X No</b></p>
<p>10. Please provide a brief overview of what was done in carrying out the assessment.</p> <p><b>Crude water balance was estimated. Did try to use a flushing time methodology but could not agree an ecology requirement for water turnover.</b></p>
<p>11. Was the assessment purely desk based, or did it involve site investigation?</p> <p><b>Mainly desk based. A few visits were made to the site.</b></p>
<p>12. What data were used, were there enough, were the data representative?</p> <p><b>Standard hydrometric data. There was not enough data, especially continuous flow and level measurement and what data was available was only representative of a small part of the site.</b></p>
<p>13. What, if any, specific tools or models were used in the assessment? How useful were they?</p> <p><b>None</b></p>
<p>14. Was the study successful? What problems arose? How confident were you in the results?</p> <p><b>Not very successful due to lack of data so not decent characterisation of the marshes was possible.</b></p>
<p>15. What gaps or needs did you identify? What would help you overcome the problems identified in Qu 14? Score 1-5 (1 =most important, 5 = least important)</p> <p><b>Continuous level measurements: 1</b>  <b>Continuous flow measurements: 1</b>  <b>Measurements of what leaves the marsh system, e.g. through tidal flaps.: 1</b></p>

## Wetland Impact Assessments

1. Wetland Name <b>Swale Marshes - Sheppey &amp; Iwade (Kent Area)</b>	
2. Wetland type  Fen/reed bed Wet Grassland Bog/ mire (upland/lowland) Wet heath Wet woodland X Other (please specify) Grazing Marsh & saline mudflats	3. Water source  X Surface-water fed Groundwater fed Combined surface-water/ groundwater fed
4. What question were you trying to answer? ie. the reason for carrying out the assessment, type of impact etc.  <b>Water availability for North Kent CAMS Appropriate Assessment for Habitats Directive.</b>	
5. What was your conceptual understanding of the wetland system and how certain were you? Did you consider hydrology, hydrogeology, ecology?  <b>Good qualitative understanding but poor quantitative understanding: lack of data. The marsh is entirely surface water fed because of the underlying London Clay. The system is then drained through the sea wall either through tidal flaps or pumps. There is some level management for shooting on Iwade and ESA on Sheppey. There are multiple water levels with water being pumped up into Capel Fleet. Hydro-ecological understanding is not that good.</b>	
6. Who did the work (Agency/consultants etc)? How many people were involved and what were their backgrounds (hydrology, hydrogeology, ecology, water quality etc).  <b>Internal Agency hydrogeologist with a background in geology (Michael Cheetham)</b>	
7. Roughly how long did the study take? A few days    X Months    Years	
8. What was the cost? X <£10k    £10-50k    >£50k	

<p>9. Did the assessment follow a standard procedure?</p> <p>Yes, please provide details</p> <p><input checked="" type="checkbox"/> No</p>
<p>10. Please provide a brief overview of what was done in carrying out the assessment.</p> <p><b>Crude water balance was estimated.</b></p>
<p>11. Was the assessment purely desk based, or did it involve site investigation? <i>eg.</i></p> <p><b>Mainly desk based. A few visits were made to the site.</b></p>
<p>12. What data were used, were there enough, were the data representative?</p> <p><b>Standard hydrometric data. There was not enough data, especially continuous flow and level measurement and what data was available was only representative of a small part of the site.</b></p>
<p>13. What, if any, specific tools or models were used in the assessment? How useful were they?</p> <p><b>None</b></p>
<p>14. Was the study successful? What problems arose? How confident were you in the results?</p> <p><b>Not very successful due to lack of data so not decent characterisation of the marshes was possible.</b></p>
<p>15. What gaps or needs did you identify? What would help you overcome the problems identified in Qu 14? Score 1-5 (1 =most important, 5 = least important)</p> <p><b>Continuous level measurements: 1</b>  <b>Continuous flow measurements: 3</b>  <b>Measurements of what leaves the marsh system, e.g. through tidal flaps.: 1</b></p>

## Wetland Impact Assessments

1. Wetland Name		<b>The Moors SSSI, Bishops Waltham</b>
2. Wetland type	3. Water source	
<ul style="list-style-type: none"> <li>✓ Fen/reed bed</li> <li>✓ Wet Grassland</li> <li>Bog/ mire (upland/lowland)</li> <li>Wet heath</li> <li>✓ Wet woodland</li> <li>Other (please specify)</li> </ul>	<ul style="list-style-type: none"> <li>Surface-water fed</li> <li>✓ Groundwater fed</li> <li>Combined surface-water/ groundwater fed</li> </ul>	
4. What question were you trying to answer? ie. the reason for carrying out the assessment, type of impact etc.		
<b>Impact of groundwater abstraction for public water supply as a precursor to AMP3 application.</b>		
5. What was your conceptual understanding of the wetland system and how certain were you? Did you consider hydrology, hydrogeology, ecology?		
<b>Abstraction was perceived to be lowering the water table and therefore drying up springs. The Chalk aquifer was assumed to supply water to the site.</b>		
6. Who did the work (Agency/consultants etc)? How many people were involved and what were their backgrounds (hydrology, hydrogeology, ecology, water quality etc).		
<b>Investigation by EA hydrogeologist followed by hydro-ecological assessment by consultant</b>		
7. Roughly how long did the study take?		
<b>5 Years</b>		
8. What was the cost?		
<b>£25k</b>		
9. Did the assessment follow a standard procedure?		
Yes, please provide details		
<b>No</b>		

<p>10. Please provide a brief overview of what was done in carrying out the assessment.</p> <p><b>Flows measured, new boreholes drilled and monitored, dip tube data collected, ecological surveys completed</b></p>
<p>11. Was the assessment purely desk based, or did it involve site investigation?</p> <p><b>Field work and data analysis and collation.</b></p>
<p>12. What data were used, were there enough, were the data representative?</p> <p><b>Data loggers and monthly monitoring of groundwater levels over several years Monthly current meter gauging of stream flows Monitoring was increased at times of high abstraction to monitor impacts more precisely.</b></p> <p><b>Surveys of wet grassland, molluscs, soils, etc.</b></p>
<p>13. What, if any, specific tools or models were used in the assessment? How useful were they?</p> <p><b>Standard hydrogeological analysis Ecological survey practice</b></p>
<p>14. Was the study successful? What problems arose? How confident were you in the results?</p> <p><b>Hydrogeology sound but as usual proving a definite connection between impacts on groundwater and impacts on ecology difficult - however, accepted by Ofwat and Defra in AMP3.</b></p>
<p>15. What gaps or needs did you identify? What would help you overcome the problems identified in Qu 14? Score 1-5 (1 =most important, 5 = least important)</p> <p><b>Published information on linking lowered groundwater levels to ecology - 3 Examples of monitoring protocols to support approach used - 3</b></p>

# Wetland Impact Assessments

1. Wetland Name	Upper Severn RSA
-----------------	------------------

## Introduction

As part of the Restoring Sustainable Abstraction Programme, the Agency must assess the possible effect of abstraction on the sites listed on the catalogue. The site list in Upper Severn consists of 29 sites, all of which require the existing abstraction regime to be reviewed. In order to gain a better understanding of the sites it is important to establish baseline data.

## Project proposal

From the existing sites in Upper Severn, there are 14 sites, which require further detailed hydrological and hydrogeological. Previous reports have been prepared for the Agency, which have proved to be invaluable in the assessment of other sites. The 14 sites that have been identified are listed on the excel attachment.

The work will aim to collate the baseline data for the sites including: -

- Previous reports
- Abstraction maps
- Surfacewater and groundwater abstraction information.
- Hydrogeological environment - maps, borehole logs etc.
- Hydrological environment - gaugings, catchment area, rainfall etc.
- Vulnerability to abstraction

Following the collection of the data, each site will be reviewed and if a further detailed report is required, the term consultancy company will be selected and invited to undertake the work. The work brief will be to provide a base line report based on a supplied list of information and data.

## Benefit

The Agency will gain a better understanding of the newly designated sites in order to fulfil our obligations in providing information to benefit the environment. The reports will enable us to assess the impact of abstraction on the RSA sites and identify further work.

## **Structure of report**

### **1. Site Details**

- 1.1. SSSI details, Name, location, NGR of site, EN reference
- 1.2. Brief description.
- 1.3. References and maps used

### **2. Geological details**

- 2.1. Ground level
- 2.2. Superficial details
- 2.3. Solid geology

### **3. Hydrogeological Environment**

- 3.1. Hydrogeology
- 3.2. Name and details of Agency observation boreholes within 3km of edge of site
- 3.3. Water features present on site
- 3.4. Evidence of link with groundwater e.g. borehole water levels, springs, gain/loss of stream flow.
- 3.5. Main groundwater abstractions (within 3km of site boundary).
- 3.6. Groundwater Management Policy
- 3.7. Vulnerability to groundwater abstractions

### **4. Hydrological Environment**

- 4.1. Hydrology
- 4.2. Name and location of nearest raingauge and its long term average.
- 4.3. Name and location of stream flow measurement site
- 4.4. Main surfacewater abstractions (upstream of the site).
- 4.5. Surfacewater Management Policy
- 4.6. Vulnerability to surfacewater abstractions.

### **5. Recommendations for further work.**

#### **Maps**

- I. Map of site
- II. Map of geology
- III. Map of borehole locations
- IV. Map of surfacewater and groundwater abstractions.



## Wetland Impact Assessments

1. Wetland Name <b>Weston Fen SSSI (Waveney &amp; Ouse valley Fens SAC)</b>	
2. Wetland type  <input checked="" type="checkbox"/> Fen/reed bed Wet Grassland Bog/ mire (upland/lowland) Wet heath Wet woodland Other (please specify)	3. Water source  Surface-water fed <input checked="" type="checkbox"/> Groundwater fed Combined surface-water/ groundwater fed
4. What question were you trying to answer? ie. the reason for carrying out the assessment, type of impact etc.  <b>Whether the proposed abstraction would affect the integrity of the site. Appendix II assessment of likely significant effect under Habs Regs.</b>	
5. What was your conceptual understanding of the wetland system and how certain were you? Did you consider hydrology, hydrogeology, ecology?  <b>It was assumed that the wetland was in hydrological contact with the aquifer. Groundwater flow and recharge considered. Ecology not considered in great detail because convincing case made for no likely effect on hydrology.</b>	
6. Who did the work (Agency/consultants etc)? How many people were involved and what were their backgrounds (hydrology, hydrogeology, ecology, water quality etc).  <b>Applicant had environmental report prepared by consultants. Checked by Agency hydro-geologist, assessment compiled by licensing officer.</b>	
7. Roughly how long did the study take? A few days      Months      Years <b>weeks</b>	
8. What was the cost? <£10k      £10-50k      >£50k <b>not quantified</b>	
9. Did the assessment follow a standard procedure? Yes, please provide details <input checked="" type="checkbox"/> <b>No Not standard for Agency WR</b>	

<p>10. Please provide a brief overview of what was done in carrying out the assessment.</p> <p><b>This had been used in a previous assessment. A short term licence had been issued because of favourable water levels and no direct evidence of lowered groundwater at the surface of the fen to enable applicant to produce an environmental report. Consultants used zone of capture method.</b></p>
<p>11. Was the assessment purely desk based, or did it involve site investigation?</p> <p><b>Mainly desk based.</b></p>
<p>12. What data were used, were there enough, were the data representative?</p> <p><b>Groundwater level data, groundwater contour maps, recharge data and calculations. Monitored near-surface groundwater level data used in a previous assessment.</b></p>
<p>13. What, if any, specific tools or models were used in the assessment? How useful were they?</p> <p><b>This limited use, as coarse screen Zone of capture - seemed useful in this case Actual water level data from the site (near-surface and lower)</b></p>
<p>14. Was the study successful? What problems arose? How confident were you in the results?</p> <p><b>Yes successful. Moderately high degree of confidence. Hopeful that the regional groundwater model will confirm.</b></p>
<p>15. What gaps or needs did you identify? What would help you overcome the problems identified in Qu 14? Score 1-5 (1 = most important, 5 = least important)</p> <p><b>Near surface dipwells should be levelled in</b></p>

Louise Evans

## Wetland Impact Assessments

<p>1. Wetland Name  <b>Witherslack mosses - actually 3 mosses; Meathop, Nicholls and Foulshaw</b></p>	
<p>2. Wetland type</p> <p>Fen/reed bed</p> <p>Wet Grassland</p> <p><input checked="" type="checkbox"/> Bog/ mire (upland/<u>lowland</u>)</p> <p>Wet heath</p> <p>Wet woodland</p> <p>Other (please specify)</p>	<p>3. Water source</p> <p><input checked="" type="checkbox"/> Surface-water fed</p> <p>Groundwater fed</p> <p>Combined surface-water/ groundwater fed</p>
<p>4. What question were you trying to answer? ie. the reason for carrying out the assessment, type of impact etc. <i>eg. Impact of proposed groundwater abstraction, or to assess whether the requirements of a specific wet grassland community are being met.</i></p> <p><b>Investigating the effects of Environment Agency land drainage maintenance regimes on raised mires and adjacent agricultural land.</b></p>	
<p>5. What was your conceptual understanding of the wetland system and how certain were you? Did you consider hydrology, hydrogeology, ecology? <i>eg. It was assumed that the fen is in hydrological contact with regional aquifer. Available data confirmed this.</i></p> <p><b>Rain fed raised mire system with extensive drainage networks, both perimeter and radial. A new conceptual model relating the hydrology of the raised mires with the water level of the main rivers was also developed.</b></p> <p><b>Considered all of the above from an early stage.</b></p> <p><b>Site investigations and existing information on the mosses confirmed this, some uncertainty remains in terms of the how the hydrology is affected by the extent of the peat surrounding the main body of the moss, especially where the peat thins.</b></p>	
<p>6. Who did the work (Agency/consultants etc)? How many people were involved and what were their backgrounds (hydrology, hydrogeology, ecology, water quality etc). <i>eg. Internal Agency assessment by hydrogeologist and ecologist</i></p> <p><b>Work sanctioned by EA (Flood Defence, Operations) due to the requirements of the Habitats Regulations and carried out by the Institute of Water and Environment at Cranfield University. Names cited by Cranfield - Tim Hess, Ian Holman, Peter Leeds-Harrison, Helen Gavin and Richard Behan. The nature of the project would require hydrologists, hydrogeologists (to a lesser extent) and ecologists.</b></p>	

7. Roughly how long did the study take? A few days      Months <b>2</b> Years
8. What was the cost? <£10k      £10-50k <b>  </b> >£50k
9. Did the assessment follow a standard procedure? Yes, please provide details <b>  </b> No
10. Please provide a brief overview of what was done in carrying out the assessment.  <b>Approach to assessment;</b> -Conceptual model - existing literature reviewed and conceptual model discussed above developed. -Surface hydrology - surface drainage system walked and mapped. Rough velocity - area method used to calculate flows using surface floats and appropriate adjustments. Allowed identification of principle drains. Other information such as freeboard and depth to clay boundaries was also collected. -Climate analysis - long term rainfall records analysed -Peat thicknesses - measured on site -Nature of Agricultural soils - measured on site and compared to published soil descriptions for the area. -Seepage modelling - series of cases modelled using simple 2D analysis.
11. Was the assessment purely desk based, or did it involve site investigation? <i>eg. Mainly desk based. A half-day visit was made to the site.</i>  <b>Extensive field work was carried out over a total of 14 days. 44 page report produced.</b>
12. What data were used, were there enough, were the data representative?  <b><i>Fairly extensive record of rainfall data for 3 local sites.</i></b> <b><i>Extensive network of dipwells on one of mosses involved.</i></b> <b>Augerring of peat and agricultural land to identify soil types.</b> <b>Crude measurement of flows in ditches - enough to get an idea of principle drains in the system.</b>
13. What, if any, specific tools or models were used in the assessment? How useful were they?  <b>Fairly simple 2D model used to predict flows and volumes. No need for exact values so useful in providing relative values of flows. This allowed important ditches to be identified.</b>

14. Was the study successful? What problems arose? How confident were you in the results?

**Successful study with well justified conclusion. Possible question mark over the time scale over which data was collected and seasonal nature of some of the data - difficult to avoid in the circumstances.**

15. What gaps or needs did you identify? What would help you overcome the problems identified in Qu 14? Score 1-5 (1 =most important, 5 = least important)

- 1. Data collection programme**
- 2. Simple tool for relating water levels in main rivers to that on the mosses**