

Certificate

Pursuant to section 12 of the Weights and Measures Act 1985

Certification No 2506

Valid Until 10 September 2008

In accordance with the provisions of section 12 of the Weights and Measures Act 1985, the Secretary of State for Trade and Industry hereby certifies as suitable for use for trade a pattern of a cubic measure as described in the descriptive annex to this Certificate, and having the following characteristics:-

Cubic brim measures of 0.5 m³, 0.6 m³ and 0.8 m³ capacity, with a bottom discharge mechanism, for use in association with a lifting and tipping mechanism in measuring ballast and agricultural materials.

Note: This certificate relates to the suitability of the equipment for use for trade only in respect of its metrological characteristics. It does not constitute or imply any guarantee as to the safety of the equipment in use for trade or otherwise.

Submitted by: **Strimech Engineering Ltd**
Longmore Avenue
Bentley
Walsall
West Midlands
WS2 0BW

Signatory:
for



J W Goulding
Director
National Weights & Measures Laboratory
Department of Trade and Industry
Stanton Avenue
Teddington
Middlesex TW11 0JZ
United Kingdom

Reference No: STD 9281

Date: 11 September 1998

CONTENTS

CERTIFICATION NO 2506

1 INTRODUCTION

2 CONSTRUCTION

2.1 Mechanical

2.2 Legends

2.3 Stamping

3 ADDITIONAL INFORMATION

ILLUSTRATIONS

- Figure 1 The pattern side 1
- Figure 2 The pattern side 2
- Figure 3 Top view of measure
- Figure 4 Side view of measure

04

Descriptive Annex

1 INTRODUCTION

This pattern of a brim measure of 0.5 m³, 0.6 m³ or 0.8 m³ is for use in measuring ballast and agricultural materials. It is a bag filler bucket, with a bottom discharge mechanism, designed for use in association with a lifting and tipping mechanism mounted on a vehicle.

2 CONSTRUCTION

2.1 Mechanical

The general arrangement of measure is illustrated in Figures 1 and 2. The measure is of welded steel construction, the steel plate being of at least 5 mm in thickness. The main body is constructed such that the upper and lower sides of the measure are at an angle of 40 degrees and 20 degrees respectively. Two side plates of 5 mm thickness are normal to the upper and lower side of the measure and are 30 degrees to one another respectively. The lower front end of the measure, which comes into contact with the ground during the filling operation, has a reinforcing toe plated of at least 16 mm thickness along its entire length. Two external wear strips of 100 x 10 thickness are attached behind the toe plate and external side strips of 100 x 10 are attached to each side plate. A reinforcing box section 80 x 80 x 5 mm thick is attached to the upper internal side of the measure.

No part of the measure projects beyond the plane formed by the upper and lower front edges and the side plates giving a clear strikeable brim and no part retains material when the measure is discharged in the normal way.

2.2 Legends

The legend 0.5 m³, 0.6 m³ and 0.8 m³ with the symbol m³ being regarded as forming only one character, is conspicuously and durably welded in characters at least 25 mm high and 10 mm wide on the nearside of the measure as it is, or is to be, mounted on a vehicle.

2.3 Stamping

The inspector's stamp shall be applied into a lead filled disc adjacent to the measure's capacity legend.

3 ADDITIONAL INFORMATION

3.1 The following may be used to check the capacity of the measure using the internal dimensions and angles shown in Figures 1 and 2.

VOLUME OF BOTTOM SECTION

$$\text{Side 1} = [(0.5 \tan E(C-D)^2) + (0.5 \tan G(C-D)^2) + (A(C-D))] I$$

$$\text{Side 2} = 2(0.5 (0.5 (H-I)) (C-D) A]$$

$$\text{Corners} = \frac{2}{3} [\tan E(C-D)^2 ((H-I)/2) + (\tan G (C-D)^2 ((H-I)/2))]$$

Volume of bottom section = side 1 + side 2 + corners

VOLUME OF TOP SECTION

$$[(0.5 D^2 \tan J) + (\sin (90-G + F) K) (\cos (90-G + F) K) \\ + [(A + (\tan E (C-D))) + (\tan G (C-D)) - (\sin (90-G + F) K)] D] H$$

Total volume = volume of bottom section + volume of top section

Note: If all above length dimensions are input as mm then the final answer should be divided by 1000,000 to give an answer in litres.

3.2 Nominal internal dimensions of each measure should be:

	0.5 m ³	0.6 m ³	0.8 m ³
A	400 mm	400 mm	400 mm
B	1023 mm	1127 mm	1250 mm
C	610 mm	670 mm	770 mm
D	100 mm	100 mm	100 mm
E	40°	40°	40°
F	6°	5.8°	5°
G	20°	20°	20°
H	1308 mm	1390 mm	1500 mm
I	730 mm	730 mm	730 mm
J	34°	35°	35°
K	80 mm	80 mm	80 mm

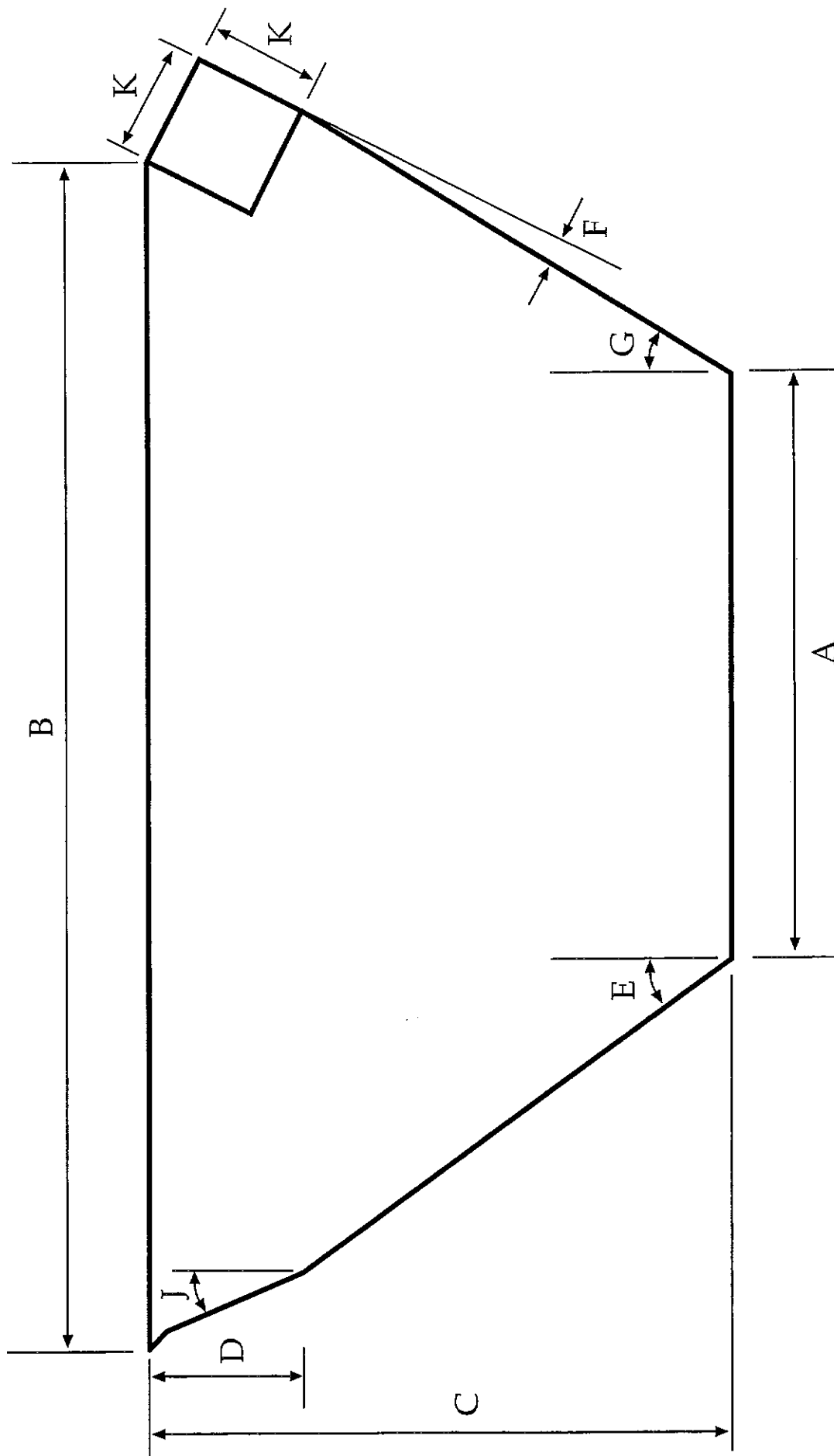

Figure 1 Line drawing, with dimensions, of the pattern side 1

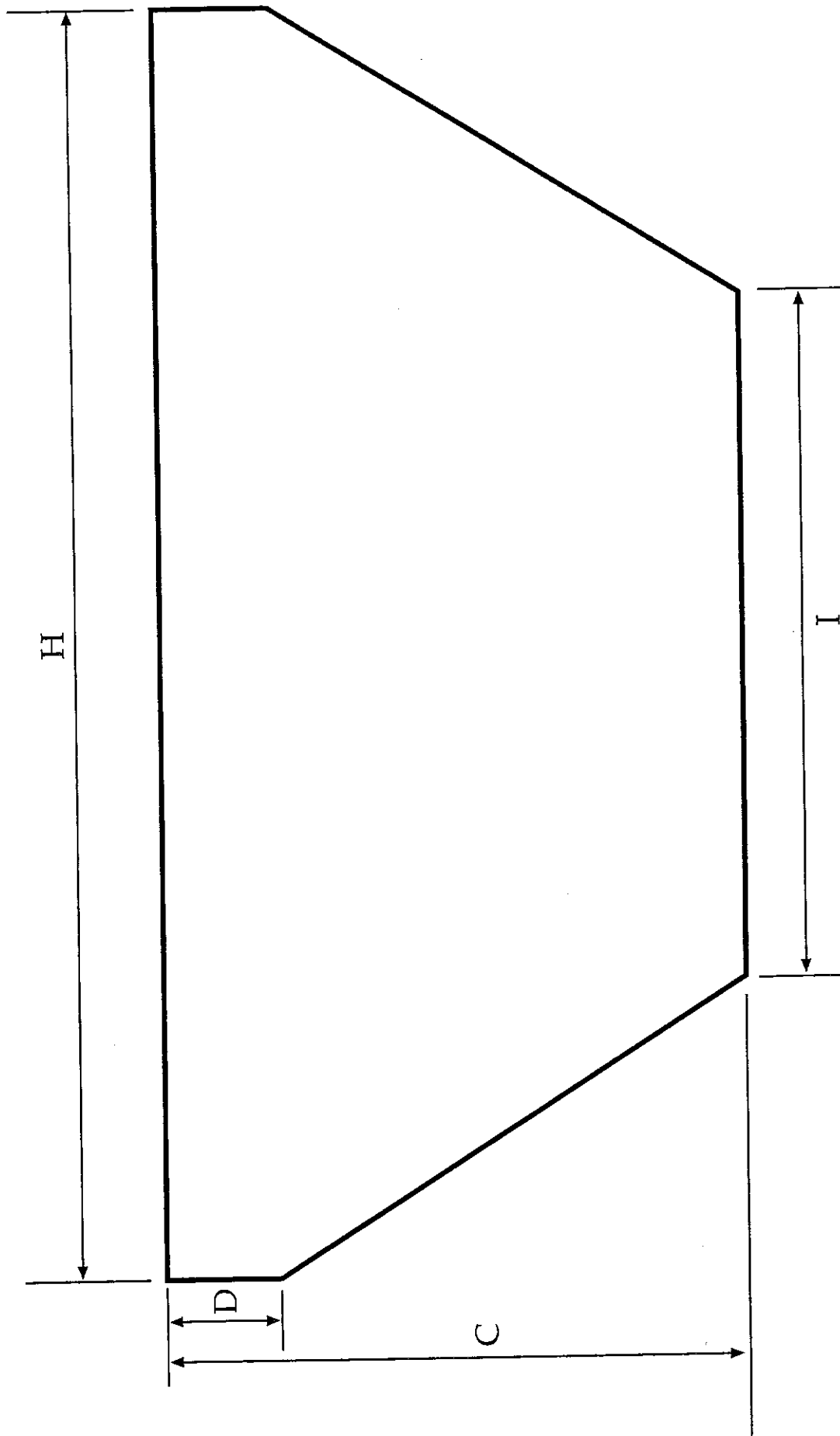

Figure 2 Line drawing, with dimensions, of the pattern side 2

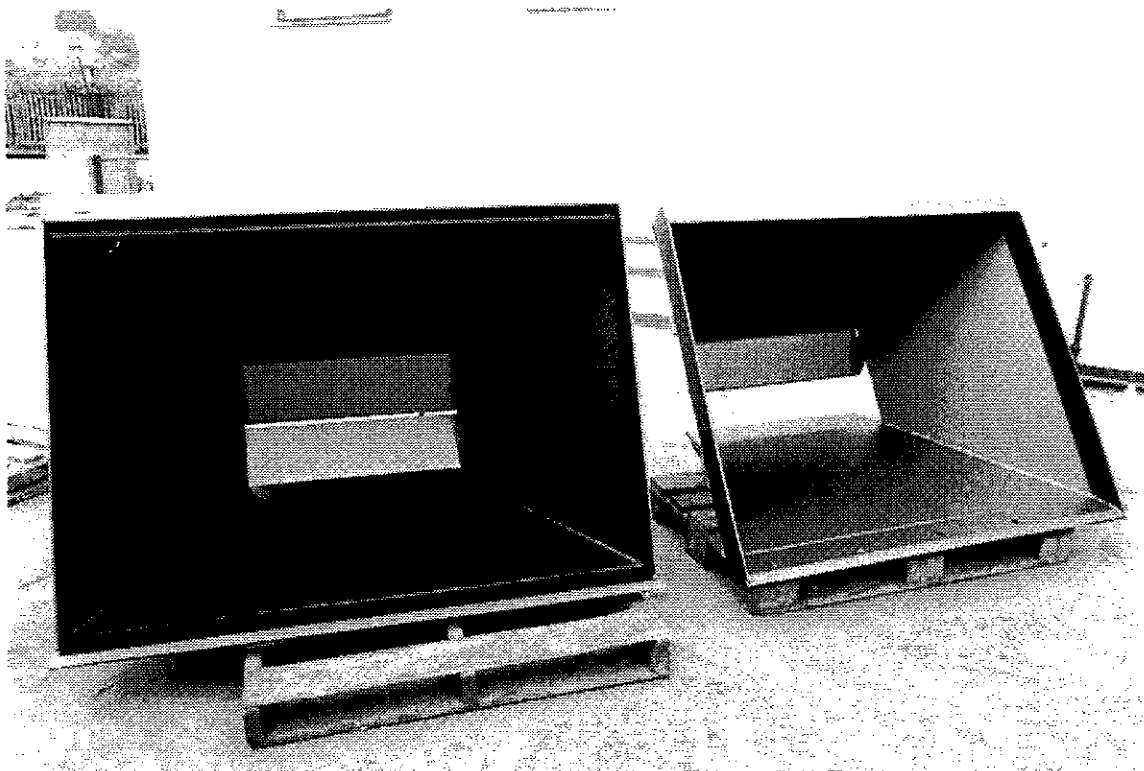

Figure 3 Top view of measure

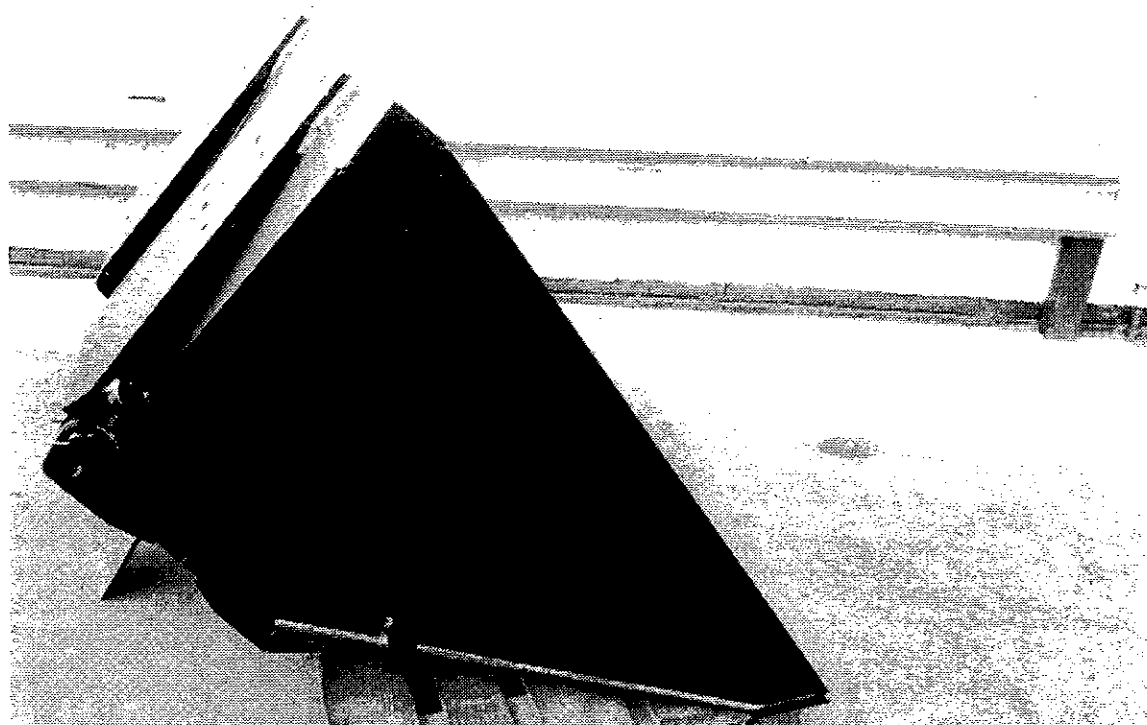

Figure 4 Side view of measure

Price £ 5.00 net

© Crown Copyright 1998

NATIONAL WEIGHTS AND MEASURES LABORATORY

Department of Trade and Industry

Printed in the UK for the Department of Trade and Industry