

(2650/76)

III(5)a

# Certificate

## Pursuant to section 12 of the Weights and Measures Act 1985

### Certification No 2650/76

*Valid Until 1 July 2016*

*In accordance with the provisions of section 12 of the Weights and Measures Act 1985, the Secretary of State for Business, Innovation & Skills hereby certifies as suitable for use for trade a pattern of a liquid flowmeter as described in the descriptive annex to this Certificate, and having the following characteristics:-*

*DISPENSER:* Gilbarco SK700 series dispensers as described in the Descriptive Annex


*POINT OF SALE SYSTEMS:* As described in the associated certificates: 2650/55

*VAPOUR RECOVERY SYSTEM:* As described in the associated certificates: 2650/55 and in the Descriptive Annex

*Under the provisions of section 12(6) of the said Act, the validity of this certificate is limited as shown above.*

*Note: This certificate relates to the suitability of the equipment for use for trade only in respect of its metrological characteristics. It does not constitute or imply any guarantee as to the safety of the equipment in use for trade or otherwise.*

*Submitted by:* **Gilbarco Veeder-Root  
Crompton Close  
Basildon  
Essex, SS14 3BA  
United Kingdom**

*Signatory:*   
*for* **P R Dixon  
Chief Executive  
National Measurement Office  
Department for Business, Innovation & Skills  
Stanton Avenue  
Teddington  
Middlesex TW11 0JZ  
United Kingdom**

Reference No: T1117/0008

Date: 22 November 2012

# Descriptive Annex

## 1 INTRODUCTION

This pattern is for an electrically driven liquid fuel dispensing system termed SK700. The SK700 series models (Figure 1) are multi-product and have up to six pumping units for 6 grades of fuel. Only one nozzle per side can be used at any one time: the withdrawal of a nozzle to start a refuelling operation prevents the delivery of any other product on the same side.

The transaction data for each side is shown on the display of the control head. The dispenser can indicate up to 999.99 Litres, giving an indication every 0.01 Litres. The price-to-pay indication indicates up to £999.99 in intervals of £0.01. The unit price increments every 0.1 pence per Litre up to a maximum of 999.9 pence per Litre.

The dispenser consists of up to six hydraulic grades, containing electrically driven monobloc pumps, hoses, optional dry break coupling, automatic nozzles, meters and pulsers connected to the electronic unit and Display Assembly. The dispenser can be operated in a self service mode via the 2 wire communication loop, or IFSF (LON) communications - and can also be operated in a standalone mode. Flow from either nozzle can be at standard rate (45 Litres/minute nominal) or at high flow rate (85 Litres/minute nominal), or at an Ultra high flow rate (120 Litres/minute).

Nozzles are mounted on one or both sides of the dispenser, providing a maximum of 6 discreet products. Both sides of the dispenser can be used at the same time. The Hose Cabinet can be either a standard hanging hoses version or can incorporate a hose retraction system. When the hose retraction system is used, the height of the Hose Cabinet is reduced.

The meter has no mechanical calibration device. The dispenser is calibrated electronically within the electronic unit.

This pattern is suitable for liquids other than water of low viscosity (<20mPa.s) except liquefied gases.

## 2 CONSTRUCTION

### 2.1 Mechanical

The frame construction is Non-Modular. There are four basic sections to the build - the hydraulic section, the electronics module, the Display module and the Hose Cabinet section. The housing of the hydraulics is constructed from a welded and bolted metal frame, the side, end and top sections being clad with metal or fibreglass panels, secured by key type locks. The electronics module is located within the top of the hydraulic housing and sits above an IP67 barrier effectively separating the two sections. The Display module is clad with metal or fibreglass panels with transparent display windows. The Hose Cabinets are constructed from a welded and bolted frame with stainless front sheathing holding the nozzle boot assemblies.

## **2.2 Hydraulics**

This consists of the monobloc pumping units, meters, solenoid valves and interconnecting pipework. Flow rate options are 40 L/Min, 80 L/Min and 120 L/Min. The option for 120 L/Min would use 2 meters in parallel.

### **2.2.1 Combined pump and air separator - Monobloc**

This is a Blackmer Monobloc unit which is to an OIML approved design, and incorporates a screw in gas detector unit which electrically connects to the electronics Intrinsically Safe Barrier board and stops the flow of fuel if excess air or gas is detected.

### **2.2.2 Meter**

There are two types of meter used in this dispenser. The 'C+ Meter' and the 'Ecometer'

The C+ meter is a positive displacement type manufactured by Gilbarco. It converts the flow of fuel into a rotary motion. The rotary motion is transmitted mechanically to the pulser. The meter may be fitted with either 4 bolts or 8 bolts. Both meters with 4 and 8 bolt fixings are shown in figure 2.

The Ecometer is a twin screw meter manufactured by Gilbarco, which converts the flow of fuel into a rotary motion which is transmitted to the attached pulser.

In both cases, for calibration purposes, an electronic calibration unit is used as described in Section 3.2

### **2.2.3 Solenoid Valves**

This is a double stemmed digital proportional valve. This valve can be used to vary the flow rate from full flow to zero flow in small increments. It is suitable for both non-preset and preset applications. It can also be used for prepay transactions, provided the kiosk equipment has been suitably approved for such.

Having an alternative valve that is analogue (proportional), with the functionality remaining the same. A picture of the proportional valve is shown in figure 3. An alternative valve driver board (part number M02044) is required to drive the proportional valve.

## 2.2.4 Nozzles

The following nozzles may be used:

Manufacturer	Model/Description	Type
Elaflex	ZVA 4.4R for use with unleaded petrol	Automatic Shut-off
Elaflex	ZVA 4.4 for use with leaded petrol and diesel	Automatic Shut-off
Elaflex	ZVA 25.41 high flow nozzle for diesel	Automatic Shut-off
Elaflex	ZVA Slimline Drip Stop nozzle Minimum Delivery 5 litres. (A legend indicating a 5 litre minimum delivery will be marked on the spout of the nozzle, this marking overrides that marked on the dispenser).	Automatic Shut-off
Elaflex	ZVA Slimline 2	Automatic Shut-off
Elaflex	ZVA X204 GRV3G for use with unleaded petrol	Vapour Recovery
Elaflex	ZVA X204 GRV3R-BL for use with leaded petrol	Vapour Recovery
Elaflex	ZVA X204M GRVP	Vapour Recovery
Elaflex	ZVA Slimline 2 GR	Vapour Recovery
Husky	Type 'X' series, single and double poppet designs. Optional accessories including swivel joints, sight glass option, and alternative spouts and splash guards which may be fitted as required.	Automatic Shut-off
Goodyear	GTR 50 for flowrates up to 50 litres /minute	Automatic Shut-off
Goodyear	GTR 80 for flowrates up to 80 litres /minute	Automatic Shut-off
Goodyear	GTR 120 for flowrates up to 120 litres /minute	Automatic Shut-off
Goodyear	GTR 50 VR	Vapour Recovery
OPW	11 VAIE-0035 for use with unleaded petrol	Vapour Recovery
OPW	11 VAIE-0037 for use with leaded petrol	Vapour Recovery
OPW	12 EN (may be fitted with different sizes of spout depending on the product type)	Automatic Shut-off
OPW	12 EN V (may be fitted with different sizes of spout depending on the product type)	Vapour Recovery

## 2.2.5 Hoses

The following hoses may be used:

Manufacturer	Model	Maximum length (Metres)
Elaflex, Germany	Conti – Slimline 25 Low temperature	6
Elaflex, Germany	Conti – Slimline 21 Low temperature	10
Elaflex, Germany	Conti – Slimline 16 Low temperature	13
Elaflex, Germany	Conti – Slimline 21 MPD	7
Good Year, USA	EN1360 TYPE 3 25mm 16 BAR M 1Q00 0310	15
Good Year, USA	EN1360 TYPE 3 16mm 16 BAR M 1Q99 0749	15
Good Year, USA	3/4" Hardwall Petrol Hose	15

## 2.2.6 Alternative Hydraulics

### 2.2.6.1 GPU 140 global pumping unit and integrated air separator

Having a Gilbarco Veeder-Root GPU 140 global pumping unit and integrated air separator. It is suitable for use in flow rates up to 140 litres per minute from a single nozzle, or 70 litres per minute for two nozzles.

The GPU 140 cover and control valve is sealed to the pumping unit as shown in figure 4. The seal wire passes through two bolt heads in the control valve body, then routed through two bolt heads in the pumping top cover casting. The two ends of the wire are then passed through the lead seal, pulled taut, and sealed.

### 2.2.7.2 Global pumping unit (figure 5a).

As described in the certificate, but having optionally fitted an alternative pumping unit:- the Gilbarco Veeder-Root Global pumping unit type GPU-90. This pumping unit is suitable for use at flow rates of up to 90 litres per minute.

The pumping unit cover and control valve is sealed to the pumping unit as shown in figure 5b. The seal wire passes through pre-drilled holes in two bolt-heads in the control valve body and is then routed through pre-drilled holes in two bolt-heads in the pumping top cover casting. The two ends of the wire are then passed through the lead seal, pulled taut, and sealed.

## 2.3 Electrical

Mains power to the dispenser is single-phase 230 V, 50 Hz, or 3 phase 400 V, 50 Hz.

The motors that drive the pumping unit are single phase or 3 phase rated up to 1.5 kW.

## 2.4 Electronics

The Electronics are known as Sandpiper. The main electronics are housed within the Electronics Module. The Display Module contains the Pump Door nodes (transaction displays), The Price Per Unit displays, the optional Electromechanical Totalisers, Power supplies, optional Battery Back up board, and Keypads.

The optional Battery Back up board supplies power to the electronics for a period of 15 minutes after mains power fail. This allows the dispenser to communicate to the kiosk equipment during power fail, and send it any transaction data stored in the dispenser. It is mainly intended for use with certain types of Kiosk equipment operating over IFSF communications and working in Buffered transaction mode.

### 2.4.1 Electronics Module

This is located above the Hydraulic section in a separate enclosure. It contains some or all of the following electronic components –

Pump Control Node board	M00056A001 or M01922A001
Valve board	M00059A002 or M02044*
STP board	M00047A001
IS Barrier board	M01267A002
IFSF Interface board	M00074G001
Vapour Recovery Controller	140489603 (MCVR125)
Ecal board	M01270A001
Pulsers (C+ Meter) (see 2.4.3)	M00786B001
	*for analogue solenoid valve control

### 2.4.2 Display Module

This contains the following electronic components –

Pump Door Node	M00062A001 or M01785A001
PPU Board	M00065A001
Electromechanical Tote Board	M00077A001
Power Control Module	M02262A001
Battery Back up Board	140 774 056
Keypad	****

### 2.4.3 Pulse Generators

The Ecometer Pulser is part of the Ecometer design and is integrated into an explosion proof housing.

The C+ meter pulser is not explosion proof and is located in the electronics module. The pulser shaft is sealed as it passes through the electronic module lower barrier and is coupled to the meter shaft.

Alternatively the SK700 pulser manufactured by Gilbarco GmbH & Co. KG may be used. The sealing arrangement is shown in figure 6

## 2.5 Displays and legends (Figure 7)

A typical dialface is shown in Figure 7. This shows the legends and the display positions.

**Notes:** The minimum delivery specified is either 2 or 5 Litres, but this may optionally be higher dependant on the maximum flow rate of the dispenser.

A dispenser may also have additional Price per unit displays for each nozzle.

<b>LEGEND</b>	<b>CHARACTER HEIGHT (mm)</b>
£	16
Litres	12
Pence Per Litre	5
Minimum Delivery 2 Litres	5

## **2.6 Standard Sealing**

### **2.6.1 Pump Control Node Sealing (Figure 8)**

The Board is fitted with a metal cover which is sealed in place with sealing wire and a lead seal. The calibration switch fitted to the metal cover is also sealed with sealing wire and a lead seal. Alternatively a plastic seal wire, rather than metallic may be used.

### **2.6.2 C+ Meter (Figure 9)**

A sealing wire passes through holes in each of the cylinder covers, the seal wire is then drawn tight and sealed with a lead seal. The meter is also sealed to the frame of the dispenser via the upper cylinder cover hole using a sealing wire and lead seal.

### **2.6.3 C+ Meter Pulser Sealing (Figure 10)**

A seal wire passes through the heads of bolts at the top of the pulser, through small holes in the pulser top and is sealed using a lead seal.

### **2.6.4 Ecometer & Pulser Sealing (Figure 11)**

A seal wire passes through 2 of the pulser fixing bolts and is sealed with a lead seal. The meter is also sealed to the frame of the dispenser using a sealing wire and lead seal.

### **2.6.5 Monobloc Gas Detector Sealing (Figure 12)**

A seal wire passes through a hole in the lower corner of the Gas Detector unit and then through a hole in the Monobloc unit and is then sealed with a lead seal. Alternatively, taking the seal wire on through a bolt at the front of the Monobloc, and through a bolt at the rear of the Monobloc in order to prevent access to the inside of the air separator.

### **2.6.6 ECAL Board Sealing (Figure 13)**

The Board is fitted with a metal cover which is sealed in place with sealing wire and a lead seal. The calibration switches are also individually sealed with sealing wire and a lead seal. Alternatively the unused switch seal plates may all be tied together with one seal wire and one lead seal. Alternatively a plastic seal wire, rather than metallic may be used.

### **3 DISPENSER OPERATION**

#### **3.1 Operating Sequence**

At the start of the transaction, the dispenser displays the previous sale. When the dispenser is in the self-service mode, the customer selects the grade of fuel required. As a result of the purchaser's activity, the operator through the kiosk control unit (if applicable), may authorise the use of the dispenser. After a display test (all '8's, all 'blanks', then all '0's). The unit price is displayed and the customer then delivers the required amount of fuel and replaces the nozzle in its stowage.

Where both sides of the dispenser are available for use, each side operates independently and separate transactions may occur simultaneously.

#### **3.2 Electronic Calibration (ECAL)**

To calibrate the dispenser a calibration coefficient is obtained by delivering a quantity of fuel into a reference volume measure. The error from the reference fuel delivered is entered into the calculator and a calibration coefficient is obtained and is stored automatically into non volatile memory. The calibration coefficient can be displayed for future reference using the appropriate keypad entries. Full details of the calibration procedure may be found in the Gilbarco technical documentation.

#### **3.3 Interlocks and Security Features**

Interlocks are provided as follows :-

- (a) The delivery is stopped when the pump detects an error condition.
- (b) In the event of a mains supply failure, displays at the dispenser are maintained for at least 15 minutes.
- (c) A period of 5 seconds must elapse before a delivery of fuel can be authorised following the replacement of the nozzle in the previous transaction.
- (d) Price per unit volume cannot be changed after any operation has been made on the dispenser to initiate a transaction and before the expiry of the 5 second guard time (as in (c)).
- (e) Any operations on the keypad inside the computing head are inhibited when a transaction is in progress on either side of the pump.
- (f) A transaction cannot be started with a price per unit volume setting of zero.

### **4 AUTHORISED ALTERNATIVES**

#### **4.1 Alternative Enclosure Arrangements**

**4.1.1** There may be any configuration of hydraulic units up to maximum of twelve hoses. There may be an unequal number of hoses.



**4.1.2** Arranged to dispense from one side of the unit only, in which case without: meters, pulsers, solenoid valves and associated pipework for the blank side. The dial mask displays and associated electronic circuitry are replaced with a blanking plate.

**4.1.3** Without electromechanical totes.

**4.1.4** Having the fuel supplied to the dispenser unit by a Submersible Turbine Pump (STP), in which case motors, pumping units & air separators are not fitted. A check valve is fitted at each of the meters in the dispensing unit and a solenoid valve is fitted. The storage tank from which the STP delivers the product shall be equipped with a level detection device. The level detection device is connected to the system to prevent the pumping unit from operating when a low level is detected.

**4.1.5** Preset operation in the kiosk, whereby the amount of volume of fuel or the price to pay for the fuel is preset or prepaid in the kiosk. In this case the dispenser must ensure the transaction stops on the exact amount of fuel preset or prepaid.

**4.1.6** With or without a hose retraction system. With the hose retraction system, the overall height is 1850 mm. Without the hose retraction system, the overall height is increased to 2165 mm.

**4.1.7** Having either one price per unit display, or price per unit displays for each grade of fuel.

**4.1.8** Multiplex version of dispenser. One Ecometer is shared by up to 3 specific grades in this configuration. This uses a Valve Block with integrated steering valves and directly connected Ecometer, and steering valves for hose selection.

The grades specified for sharing must be fuels that will not suffer cross-contamination, for example, various petrol grades.

Dispensers thus modified shall indicate that minimum delivery is 5 litres.

**4.1.9** With any nozzle with high flow-rate capability configured as dual speed (standard flow or high flow) selectable via a push-button switch adjacent to the nozzle. The nozzle shall return automatically to standard flow upon completion of high flow delivery.

**4.1.10** With high flow nozzles on both sides of the dispenser driven by an ultra high flow monobloc (120 L/min).

## **4.2 Alternative Dispenser Styles**

### **4.2.1 LPG module**

Having an LPG dispensing module, either in the form of a separate dispenser, or in addition to other modules, such as being integrated into a multiproduct dispenser. The LPG module contains parts suitable for use with LPG. Transaction data for the LPG section may connect to approved site control equipment.

**Note:** The LPG hydraulics are not prescribed under the Liquid Fuel and Lubricants Regulations.

#### **4.2.2 H Frame construction - Encore 510 (Figure 14)**

As described in the Certificate, but having a new style enclosure designated the 'Encore 510'. This is an 'H' Frame style of dispenser, having a hose retractor unit separate from the main hydraulics. The manager keypad and electromechanical totalisers are accessible via hinged drop down doors situated on the front panel of the computer head

Sealing is similar to that of the standard with the exception of the pulser used with the C+ meter, the wire passes through the bolt which fixes the pulser to the pulser bracket, the wire then passes through the bolt which fixes the pulser bracket to the meter. The ends are brought together and both covered by a seal. The pulser is manufactured by Eltomatic and the sealing method is illustrated in figure 15.

#### **4.2.3 Encore 500G (Figure 16)**

This is an 'H' Frame style of dispenser. An alternative Transaction Display board is included (M07856), which has a single piece LCD glass with larger Price to Pay Digits.

The manager keypad and optional Electromechanical Totalisers are accessible via hinged drop down lockable doors situated on the front panel of the Computer Head.

Note: The Computer Head is designed to be fitted with optional Card Reader components (Display, Card Reader, PIN PAD, and printer). These do not form part of this approval, and the Computer Head is fitted with blanking plates to cover the apertures for these devices.

#### **4.2.4 Infoscreen (Figure 17)**

Having an Info Screen terminal attached, this is a display terminal, providing picture and sound for advertising, safety announcements, and travel information etc. The signal can be supplied from disk, satellite broadcast, ethernet or any other suitable display source, all of which are either mounted remotely from the dispenser, or located inside the Computer Head. The dispenser may be configured with a screen on one, or both sides. The screen sizes can be typically 5.7", or can be up to a PC screen size of typically 17".

#### **4.2.5 End Accessed SK700 Dispenser**

As described in the certificate, but having the Dispenser hoses in an 'End Accessed' style.

- Single Hose Version (Figure 34). A single hose version can serve both sides of the dispenser with the transaction being displayed on both sides of the Computer Head simultaneously. This only requires one set of hydraulics.
- Two hose version (Figure 35). A two hose version can dispense the same grade of fuel to each side, or can dispense different Grades of fuel to each side, dependent on the hydraulics fitted.

Flow rates can be either 40 LPM, 80LPM or 120 LPM also dependent on the hydraulic and type of Pumping unit fitted. LPG hydraulics may be installed as described in section 4.2.1.

#### **4.2.6 Adblue**

Having an Adblue dispensing module, either in the form of a separate dispenser, or in addition to other modules, such as being integrated into a multiproduct dispenser. The Adblue module contains parts suitable for use with Adblue. Transaction data for the Adblue section may connect to approved site control equipment.

**Note:** The Adblue hydraulics are not prescribed under the Liquid Fuel and Lubricants Regulations.

#### **4.2.7 Nordic Lane Dispenser (Figure 46)**

As described in the certificate, but with Cosmetic changes to the packaging.

The Computer Head is slightly smaller than the standard SK700, and the optional PPU displays are fitted vertically on the Computer Head Door. Several of the panels are now curved, to give a more rounded look to the Dispenser aesthetics.

#### **4.2.8 Taller Hose Cabinet SK700 (Figure 48)**

As described in the certificate, but with an increased hose cabinet height which is approximately 2400mm high which allows for a longer hose reach.

Any approved payment terminal under certificate 2650 may be fitted as an option, either below the computer head as shown, or integrated into a larger computer head.

Any approved display types may be fitted. The 'Price Per Unit' displays may be fitted either horizontally or vertically in the computer head.

#### **4.2.9. Horizon Dispenser (Figure 49)**

This is an alternative 'H' frame style of dispenser. It may include the transaction display (M07856) with larger digit displays as introduced with the Encore 500G dispenser. The electronics enclosure is accessed via a large door, which is normally manufactured from plastic. Painted steel versions are also permitted. This door also carries the nozzle boots. The computer head is designed to be fitted with optional card reader components. These do not form part of this approval, and the computer head is fitted with blanking plates to cover the apertures for these devices.

#### **4.2.10 Horizon Dispenser with integrated SPOT M3 (Figure 51)**

Having the Horizon style dispenser frame as described in section 4.2.9, with the Spot M3 payment terminal as approved in Supplement Certificate Series S030 integrated into the dispenser housing.

#### **4.2.11 Horizon Dispenser with Hose Retraction (Figure 56)**

Having the Horizon style dispenser as described in section 4.2.9 fitted with a hose retraction system in the space above the electronics enclosure.

## 4.2.12 397G Dispenser (Figure 61)

As described in the certificate but having an alternative style enclosure designated 397G. This is most commonly configured as a single or two product dispenser with nozzles mounted in the columns and with displays allowing use of the nozzle on either side of the dispenser. However, alternative arrangements exist which have a single display per side and dedicated hoses per side (up to two products and four nozzles, max of one nozzle active per side).

## 4.3 ALTERNATIVE ELECTRONICS – SANDPIPER 2

### 4.3.1 General Description

The original electronics are replaced with the Sandpiper 2 electronics within the Computer Head. The only electronic board now within the hydraulic unit is an ‘IS Hub’ which is used to interface to pulsers and switches.

Sandpiper 2 also includes alternative pulsers. The Ecometer now uses an Eltomatic Pulser ME01-04, and the C+ Meter uses a Gilbarco Veeder-Root IS Pulser type M03127. Sealing of these pulsers and associated boards are described in section .

Cables are routed into the computer head via a new cable channel in the column and enter the computer head via a ventilated channel underneath. Alternatively for the Encore 510, H-frame construction, the cables are routed into the computer as before, via optional cable glands into the side of the head. Minor changes have also been made to the Hydraulic Frame, the panels and the Computer Head.

The Sandpiper 2 Boards consist of –

CPU board	M06104
Display board	M06113
ECAL board	M06110
Valve board	M06031
IS interface board	M06202
STP connector board	M06107
Single phase AC connector board	M06214
IS hub board	M06205
Battery back-up board	M06208
PPU board	M04329
IFSF board	M00074

Vapour recovery and vapour monitor boards may also be added.

### 4.3.2 Securing (Sealing)

#### 4.3.2.1 In the computer head

CPU board: - (Figure 18) The board is fitted with a metal cover which is sealed in place with a securing (sealing) wire (metal or plastic) and a seal. The calibration switch is protected by a sealed plate which is sealed by a securing (sealing) wire (metal or plastic) and a seal.

ECAL board:- (Figure19) The board is fitted with a metal cover which is sealed in place with a securing (sealing) wire (metal or plastic) and a seal. The meter calibration switches (16 total) are

each protected by a sealed plate which is sealed by a securing (sealing) wire (metal or plastic) and a seal.

IS interface board:- (Figure 20) The board is fitted with a metal cover which is sealed in place with a securing (sealing) wire (metal or plastic) and a seal.

#### 4.3.2.2 In the hydraulic unit

IS hub:- (Figure 21) The board is fitted with a metal cover which is sealed in place with a securing (sealing) wire (metal or plastic) and a seal. The pulser connectors (8 total), the switch connector, the gas detector connector (where fitted) and the Comms connector (to computer head) are each protected by a sealed plate which is sealed by a securing (sealing) wire (metal or plastic) and a seal.

C+ pulser:- (Figure 22) The pulser is sealed in place to the frame with a securing (sealing) wire (metal or plastic) and a seal. The cover of the pulser is sealed with a securing (sealing) wire (metal or plastic) and a seal.

Ecometer and pulser:- (Figure 23) The Ecometer and associated pulser is sealed with a securing (sealing) wire (metal or plastic) and a seal. The meter is also sealed to the frame of the dispenser with a securing (sealing) wire (metal or plastic) and a seal, except for the Encore 510, H-frame constructed model.

C+ Meter :- (Figure 24) A seal wire passes through holes in each of the cylinder covers, and is sealed with a securing (sealing) wire (metal or plastic) and a seal. The meter is also sealed to the frame of the dispenser via the upper cylinder cover hole with a securing (sealing) wire (metal or plastic) and a seal, except for the Encore 510, H-frame constructed model.

#### 4.4 ALTERNATIVE METER – ENDRESS AND HAUSER CORIOLIS METER

As described in the certificate but with all or some of the meters replaced with an ‘Endress and Hauser’ Coriolis meter type ‘LPGMass’ model DN15. The meter connects to the existing ‘IS Hub’, but the IS Hub is now located within the Computer Head of the Dispenser. The meter is calibrated using the same electronic calibration procedure as before.

The Meter is sealed as shown in Figure 47. There are 2 seals connected to one seal wire, which seal the 2 compartments, protecting the wiring terminals and configuration switches. The position of the 4 Switches in the meter electronics housing should be set as below:

Switch a	-	Down	
Switch b	-	Down	
Switch c	-	Up	(Set to Volume Mode using the measured density of the liquid)
Switch d	-	Up	(Set to ‘Secure Operation Mode’ No Write access is possible)

#### 4.5 ALTERNATIVE METER – V+ METER (Figure 50)

As described in the certificate but with all or some of the meters replaced with a V+ meter. The meter is based upon the C and C+ meter families, but has modifications to the meter cylinder end covers. A single seal wire seals all four meter cylinder covers and picks up two seal wire points in the meter top cover. The exact routing of the seal wire may vary dependent upon the model of dispenser in which the meter is installed. The meter is also separately sealed to the frame of the dispenser via a hole in one of the cylinder covers.

#### **4.6 ALTERNATIVE PULSER - SECURE INTELLIGENT PULSER (SIP)**

The Secure Intelligent Pulser (SIP) mounts to the C+ or V meter and determines the quantity of fuel dispensed by counting revolutions of the pulser input shaft. It stores the calibration factor for its associated meter. A W&M-sealable switch is provided to control the changing of the calibration data, and other basic configuration data. When the calibration switch is in the normal sealed position, the pulser rejects any attempts to change the calibration data or configuration data. When the switch is in the unsealed position, the pulser accepts correctly formulated data from the CPU, and saves the data in non-volatile storage. Data encryption is employed for the CPU to pulser communication. There is a non-volatile log of the most recent change, which can be read by the CPU via the serial bus. To put the pulser into calibration mode, a cap is removed and an LED, provided by GVR, is inserted into the top of the calibration light tube/ programming port. Typical pulser is sealed as shown in Figure 52.

#### **4.7 ALTERNATIVE SEALING METHOD – ECAL, IS HUB, ATC HUB**

The pulser connections into the IS hub, and the temperature probe connections to the ATC Hub, may alternatively be sealed using tamper evident sticker seals over the flat screw heads used to secure the sealing plates. The ECAL board may use similar tamper evident sticker seals to cover the small access holes to the ECAL switches. Examples are shown in Figure 53.

#### **4.8 ALTERNATIVE DISPLAY BOARD**

The amount, volume and price per unit may be combined into a single display board (M10738) as shown in Figure 54. Price per unit displays for multiple fuel grades may optionally be mounted onto a single board (M10735) as shown in Figure 55.

#### **4.9 ADDITIONAL RS485 COMMUNICATIONS INTERFACE CONVERTER (M06211)**

An additional board may be used for conversion of the communications to RS485.

#### **4.10 VOLUME ONLY DISPENSERS**

Having the dispenser display masked such that only the volume is displayed.

#### **4.11 ALTERNATIVE DISPLAY BOARDS**

The amount, volume and price per unit may be indicated by a multimedia display (DIMP) as shown in Figure 58. Display digits and text heights are in accordance with those defined within this certificate. The metrologically relevant indication is permanently displayed, and is segregated from non-metrological display content. In the event of a power fail, the primary display is provided by an internal display as shown in Figure 59.

#### **4.12 Alternative version of SIP Pulser**

As described in the certificate but with the Secure Intelligent Pulser (SIP) in a smaller housing and with an alternative calibration switch arrangement. The same light activated calibration circuit is used; but the pulser is fitted with an internal light source. To put the pulser into calibration mode, the seal wire is removed from a screw feature, and the screw is rotated by 90 degrees to turn a mechanical light reflector. The pulser is typically sealed as

shown in Figure 60.

## 5 STAGE II VAPOUR RECOVERY

### 5.1 Construction

#### 5.1.1 Components

The systems described typically consist of a mix of standard components described below:-

(a)	Vapour recovery nozzle	See section 2.2.4
(b)	Vapour recovery hose	See section 2.2.5
(c)	Vapour pumps	ASF 8014 series Durr MEX 0831 series GR125 Alternatively any vapour recovery pumps approved for use by TUV (Note: These vapour pumps are typically driven via either a single ended or double ended AC motor)
(d)	Proportional valve	Burkert 2832 series Burkert 6022 series
(e)	Fuel / vapour splitter adaptor	Elaflex ZAF series
(f)	Electronic control unit for vapour recovery system	Burkert 1094 series Gilbarco VRC390/392 series MCVR125
(g)	Optional vapour meter	Gilbarco Veeder-Root GE1 meter. Alternatively any Gilbarco Veeder-Root (or Fafnir – Figure 57) meter for vapour monitoring systems approved for use by TUV
(h)	Electronic control unit for vapour monitoring system	Gilbarco VMC390 /392 series Alternatively any Gilbarco Veeder-Root (or Fafnir) electronic control unit for vapour monitoring systems approved for use by TUV
(i)	Kiosk alarm indicator	Gilbarco KAI392 Any kiosk equipment (eg: POS) with suitable interface. Alternatively any Gilbarco Veeder-Root electronic control unit for vapour monitoring systems approved for use by TUV

## **5.2 Operation**

**5.2.1** When fuelling commences, the fuel delivered displaces the vapour contained within the vehicle fuel tank and the vapour is therefore forced out. The vapour pump is used to collect the vapour as it emerges from the fuel tank. Referring to figure 25, the path of the vapour flow is:-

Via the outer ring of the nozzle >  
On into the inner core of the coaxial hose >  
Into the splitter hose connector (ZAF) >  
Out of the splitter hose connector into the vapour pipe >  
Through the vapour monitor meter (if fitted) >  
Through the proportional valve >  
Through the vapour pump >  
Then out through the shear valve and back to the underground tank.

**5.2.2** The vapour recovery controller electronics is used to match the recovered vapour rate with the fuel flow rate. It does this by adjusting the proportional valve to obtain the vapour flow rate in line with the fuel flow as indicated by the fuel meter pulser. This way, the vapour recovery volumetric efficiency is kept within the 95 to 105% level.

**5.2.3** The vapour recovery controller electronics is calibrated using an external gas meter connected to a handheld terminal. The handheld terminal interfaces to the vapour recovery electronics by a serial port and initiates a calibration sequence. This is accomplished without any fuel delivery and with only air being measured, also with a calibration factor being used which makes allowance for the difference between air and vapour and the particulars of the system components used.

**5.2.4** An optional vapour monitoring system may also be used. This is used to check the correct operation of the vapour recovery system. A vapour meter is used to measure the vapour being recovered. This interfaces to the vapour monitor electronics, which compares this with the fuel delivered and, if after a number of consecutive transactions the vapour recovered is outside of specification, the monitor will indicate an alarm. This gives the owner time to have the system repaired before the fuelling point is automatically shut down.

**5.2.5** If a vapour monitoring system is not used, the recovery system will need to be checked for correct operation on a regular basis.

**5.2.6** The monitor alarm can be either indicated at the dispenser (eg: via an LED) or a signal can be sent to the kiosk via the standard data communication line to the POS and indicated at the POS itself. Optionally, a special 'kiosk alarm indicator' (KAI) can be fitted which interfaces to the monitor system via a serial channel and indicates the alarm details in the kiosk

## **5.3 Additional Two Wire Enhanced Vapour Recovery Monitor (TEM)**

The TEM is used to allow Vapour Recovery Alarms to be returned from Vapour Monitoring Controllers in dispensers, to the Automatic Tank Gauge (ATG) in the kiosk. This utilizes the normal Gilbarco Two-Wire dispenser - kiosk communication channels, and avoids the need to lay extra cables. The Alarms can be retrieved from the ATG using its existing interfaces.

A typical site using a TEM is as shown in Figure 36. This shows the existing Two-Wire



cables from the Site Controller to the dispensers now passing through the TEM inside the Kiosk. No modification is required to the Site Controller. The TEM collects status data which is already present in the existing messages. One TEM is capable of connecting to, and monitoring, up to eight Two-Wire loops (only four are shown).

The TEM Module is shown in Figure 37, it consists of a metal box housing a standard CE-marked power-supply module and a printed circuit board. The Two-Wire cables connect to the printed circuit board, which is a passive monitor of the data on the Two-Wire current-loops. The TEM is a read only device on the Two-Wire current loop, it cannot write to the loop or change the data in any way. The Two-Wire current loops are unbroken even when the TEM is powered down. The TEM connects to the Two-Wire current loops by means of optoisolators (one per loop) with a minimum breakdown voltage of 5300 V (Figure 38).

## **6 VOLUME CONVERSION DEVICES**

### **6.1 TVC volume conversion device (Temperature compensation device)**

#### **6.1.1 System Description**

The TVC is a conversion device for use with two meters, intended for correcting volumes of fuel as if dispensed at 15°C. The temperature compensation function is added by connecting the TVC unit between the pulse output of the dispenser pulser and dispenser calculator. The TVC provides a pulse output stream corrected for temperature by monitoring the temperature of the fluid passing through the meter. The pulse output is no longer a fixed number of pulses per rotation of the meter output shaft, but adjusts the volume of fuel as if it is dispensed at 15°C. The TVC unit is shown in figure 26.

The conversion calculation for a certain density of fuel is determined by the selection of a suitable density block (module) as shown in figure 28. The density block contains the calculations as specified in the ASTM manual D1250-80, table 4. The density blocks are identified as follows:

Module identification	Density range in kg/m <sup>3</sup>
B1	720 - 730
B2	730 - 740
B3	740 - 750
B4	750 - 760
B5	760 - 770
B6	770 - 780
D1	810 - 820
D2	820 - 830
D3	830 - 840
D4	850 - 860

#### **6.1.2 Construction**

##### **6.1.2.1 TVC unit**

The TVC circuit board is housed in a secure box which prevents unauthorised access to the calibration button and the power supply, data link, temperature sensor, density block and pulser connections. The box has a clear lid to allow inspection of the density block.

Optionally an LCD display (figure 27) may be installed which allows access to the following data by pressing the scroll button:

- Fixed Density
- Temperature (Actual temperature from liquid)
- Uncompensated volume 1(last delivery, 2 digits behind the comma)
- Uncompensated volume 2(last delivery, 2 digits behind the comma)
- When test button is pressed, display shows “bypass”
- Display shows “ERROR” when the TVC is defective or errors occur

#### **6.1.2.2** Temperature sensor

A temperature sensor manufactured by E. Meurs BV and designated LM335 is connected to the TVC unit. The temperature sensor (figure 29) is installed in the fuel delivery pipe within one metre from the flow meter; a typical installation is shown in figure 30.

#### **6.1.2.3** Software

An infrared port in the TVC unit allows the reading of data and performing the calibration via an infra red reader connected to a portable PC running the Windows based software ‘Fuel Monitor’, produced by E. Meurs BV. A typical data display is shown in figure 33

The software version number is: V1.01 and can be accessed with the ‘Fuel Monitor’ software, or by viewing the LCD screen in the TVC unit where fitted.

#### **6.1.2.4** Indication of measurement result

A legend shall be affixed adjacent to the volume indication clearly indicating that the volume dispensed is corrected to 15 °C.

#### **6.1.3** Adjustments

Adjustments to the calibration and temperature compensation of the TVC unit may be made using a PC having an infra red link and running ‘Fuel Monitor’ software or using the scroll buttons if the TVC unit has an LCD display.

#### **6.1.4** Sealing

**6.1.4.1** The TVC unit is sealed as shown in figure 31.

**6.1.4.2** The temperature sensor is secured to prevent removal from the T-connector and the T-connector from the fuel pipe by routing a sealing wire through the sensor and around the pipe connection (figure 32).

#### **6.1.5** Recommended tests

Check that the correct software version is installed in the TVC unit

## **6.2 Gilbarco ATC (Automatic Temperature Compensation)**

### **6.2.1 System Description**

The ATC system compensates for temperature effects on the measured volume, thus the temperature compensated volume correspond to the product volume at 15 °C. The volume conversion factor, VCF, which is the quotient between the uncompensated and the compensated volume is calculated, and used to do the compensation.

The VCF is based on three quantities; product type and its corresponding density; and product temperature. Product type and product density are entered in the ATC setup and the system reads the momentary product temperature and calculates the VCF. The compensated volume is used for the normal transaction data i.e. showed on the display.

### **6.2.2 Construction and Installation**

The ATC system is consists of:

ATC Hub Board M07876 (Figure 39)

ATC Manifold 140911293 (Figure 40)

ATC temperature sensor with NPT 1/4" BQ109009-RTD 1,2 or 3 (Figure 41)

The ATC Hub is connected to the IS-Interface (M06202) via IS cable 140 847 166. Each ATC Hub can have up to 4 temperature sensors and therefore 4 pumping units, if there are more than 4 units a second ATC HUB is required. This second hub is connected as shown in figure 42.

The Hub board is in a prefabricated case, it is installed on the supporting rail in the hydraulic section of the dispenser using M5 self cutting screws, as shown in figure 43. If a second Hub is installed this is fitted in the hydraulic section for the fifth and sixth units, which are on the other side of the hose cabinet.

### **6.2.3 Settings**

The ATC set up is done via the dispenser manager keypad in the computer head, the calibration switch on the dispenser CPU must be switched on. Once installation is complete the calibration switch should be turned off and the CPU sealed as described in the descriptive annex.

**6.2.3.1** The density of each product is set in parameter 75, in the following format: 75 1 X, where "1" is the relevant pumping unit and X is the product type. The product types and their appropriate densities are set as follows, where the density is in kg/m<sup>3</sup>:

1 - CNG (730)

2 – Na-Diesel (840)

3 – VK 92/95 (745)

4 - VK 98 (745)

5 – Diesel (833)

6 – VK 98 leaded(755)

7 – E85 (785)

**6.2.3.2** The temperature and non-compensated volume can be checked whilst in calibration mode by pressing key "7" on the manager keypad during a dispense. The displays will switch to the ATC test mode, the price display shows the non-compensated volume, and the litre display shows the compensated volume. The price per litre display shows the current liquid temperature.

#### **6.2.4** Sealing

**6.2.4.1** The IS Interface and calibration switch are sealed as described in section 4.3.

**6.2.4.2** The ATC Hub is sealed by a cover seal on one of self cutting screws securing the Hub to the supporting rail in the hydraulic section. Additional hooks over the cabling protect the temperature sensor connections (Figure 44).

**6.2.4.3** The temperature probes are secured into the manifold as shown in Figure 45.

#### **6.2.5** Conditions

For dispensers providing temperature compensation, the primary indicator (dispenser display) shall clearly indicate that the volume dispensed is corrected to 15 °C.

## **7 CONNECTION TO MID APPROVED FUEL DISPENSERS AND SELF-SERVICE DEVICE SYSTEMS**

### **7.1** Self-Service Devices

The dispensers in this approval may be connected to any compatible MID POS having an EC Parts Certificate.

The dispensers may be connected to the Passport POS system having EC Evaluation Certificate TC7581.

### **7.2** Fuel Dispensers

The dispensers may be used in a system which also includes dispenser models described in this certificate but which have been conformity assessed in accordance with The Measuring Instruments (Liquid Fuel and Lubricants) Regulations 2006 (SI 2006 No 1266) which implement the Measuring Instruments Directive (2004/22/EC). These dispensers may be as described in the following MID EC type-examination certificates:

UK/0126/0073 (Horizon),  
T10055 (SK700, SK700-2, Encore 510, SK700-2/Horizon, SK700-2/xxx),

### **7.3** Non-prescribed Liquid Dispensers

The dispensers may be used in a system which also includes Adblue and/or LPG dispenser models having a MID EC type-examination certificate. These dispensers may be as described in the following MID EC type-examination certificates:

T10058 (SK700 Adblue),  
T10154 (SK700-2, Encore 510, SK700-2/xxx LPG dispensers)

## **8 CONNECTION TO UK NATIONAL APPROVED POINT OF SALES SYSTEMS**

**8.1** The validity date of 1 July 2016 applies to the following point of sales approvals:  
2650/55

## **9 RECOMMENDED TESTS**

**9.1** Verify the accuracy of measurements and computation at the dispenser using both current unit prices and near maximum unit prices.

**9.2** Check that a display test - all '8's, blanks, and all '0's appear on the dispenser display at the start of sale

**9.3** Check that unit price changes are inhibited when a sale is in progress.

## **10 ILLUSTRATIONS**

- Figure 1 SK700 Dispenser**
- Figure 2 Alternative meter caps**
- Figure 3 Analogue Solenoid Valve**
- Figure 4 GPU 140 global pumping unit and integrated air separator**
- Figure 5a GPU-90 Pumping Unit**
- Figure 5b GPU-90 Pumping Unit Sealing**
- Figure 6 SK700 sealing arrangement**
- Figure 7 Typical Dialface Legends**
- Figure 8 Pump Control Node Sealing**
- Figure 9 C+ Meter Sealing**
- Figure 10 C+ Meter Pulser Sealing**
- Figure 11 Ecometer Pulser & Meter Sealing**
- Figure 12 Monobloc Gas Switch Sealing**
- Figure 13 ECAL Board Sealing**
- Figure 14 General view of Encore 510 dispenser**
- Figure 15 Encore 510 pulser securing**
- Figure 16 General View of Encore 500G**
- Figure 17 Typical Computer Head Door with Infoscreen. (Encore 500G)**
- Figure 18 Sandpiper 2 - CPU board securing (sealing)**
- Figure 19 Sandpiper 2 - ECAL board securing (sealing)**
- Figure 20 Sandpiper 2 - IS interface board securing (sealing)**
- Figure 21 Sandpiper 2 - IS hub securing (sealing)**
- Figure 22 Sandpiper 2 - C+ pulser securing (sealing)**
- Figure 23 Sandpiper 2 - Ecometer securing (sealing)**
- Figure 24 Sandpiper 2 - C+ Meter securing (sealing)**
- Figure 25 Typical vapour recovery system**
- Figure 26 TVC unit without LCD display**
- Figure 27 TVC unit with LCD display**
- Figure 28 TVC Density blocks**
- Figure 29 TVC Temperature sensor: LM335**
- Figure 30 TVC Typical installation of temperature sensor**
- Figure 31 TVC unit sealing arrangement**

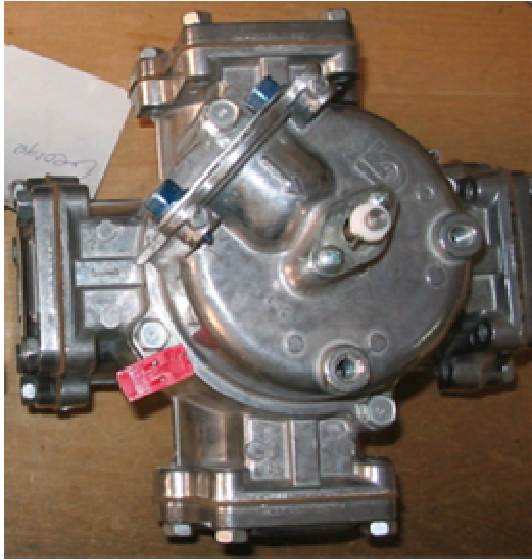
<b>Figure 32</b>	<b>TVC Typical installation of temperature sensor and sealing arrangement</b>
<b>Figure 33</b>	<b>TVC Typical display of measurement data using ‘Fuel Monitor’ software</b>
<b>Figure 34</b>	<b>Typical Single Hose Dispenser</b>
<b>Figure 35</b>	<b>Typical 2 Hose Dispenser</b>
<b>Figure 36</b>	<b>Forecourt System Diagram showing TEM</b>
<b>Figure 37</b>	<b>TEM Module</b>
<b>Figure 38</b>	<b>TEM Block Diagram</b>
<b>Figure 39</b>	<b>ATC Hub Board</b>
<b>Figure 40</b>	<b>ATC Manifold showing temperature sensor and test sleeve</b>
<b>Figure 41</b>	<b>ATC Temperature Sensor</b>
<b>Figure 42</b>	<b>ATC Hub Connections</b>
<b>Figure 43</b>	<b>ATC Hub mounted on hydraulic section supporting rail</b>
<b>Figure 44</b>	<b>ATC Hub Sealing</b>
<b>Figure 45</b>	<b>ATC Temperature Sensor Sealing</b>
<b>Figure 46</b>	<b>Nordic Lane Dispenser RHS</b>
<b>Figure 47</b>	<b>Coriolis Meter Sealing</b>
<b>Figure 48</b>	<b>Taller Hose Cabinet SK700</b>
<b>Figure 49</b>	<b>Horizon Dispenser</b>
<b>Figure 50</b>	<b>V meter sealing example</b>
<b>Figure 51</b>	<b>Horizon Dispenser with integrated Spot M3</b>
<b>Figure 52</b>	<b>Typical Secure Intelligent Pulser (SIP) sealing</b>
<b>Figure 53</b>	<b>Alternative Sealing – Tamper evident sticker seals</b>
<b>Figure 54</b>	<b>Combined Amount, Volume and Price per Unit Display</b>
<b>Figure 55</b>	<b>Multiple Price per Unit Display</b>
<b>Figure 56</b>	<b>Horizon Dispenser with Hose Retraction</b>
<b>Figure 57</b>	<b>Fafnir Vapour Monitor</b>
<b>Figure 58</b>	<b>DIMP Multimedia Display – typical display arrangement</b>
<b>Figure 59</b>	<b>Internal display for DIMP Multimedia Display</b>
<b>Figure 60</b>	<b>Typical Secure Intelligent Pulser (SIP) sealing – shorter body version</b>
<b>Figure 61</b>	<b>397G Dispenser</b>

**11 CERTIFICATE HISTORY**

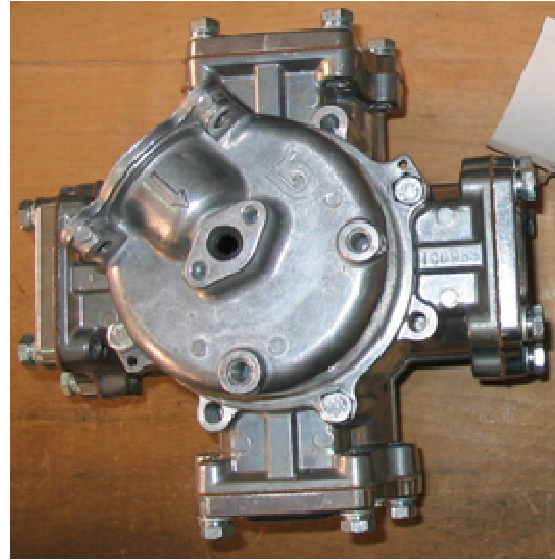
<b>ISSUE NO.</b>	<b>DATE</b>	<b>DESCRIPTION</b>
2650/76	23 November 2012	Certificate first issued.



**Figure 1** SK700 Dispenser



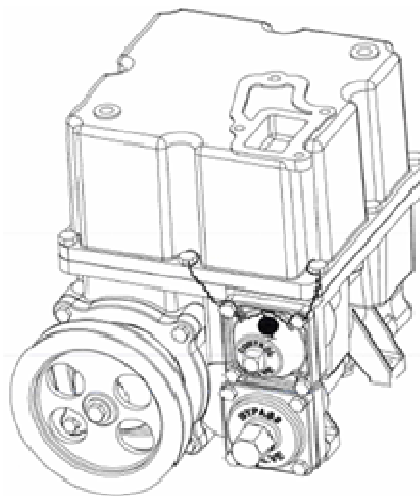
**4 Bolt meter cap**  
**Figure 2**



**8 Bolt meter cap fitted with 4 bolts**  
**Alternative meter caps**

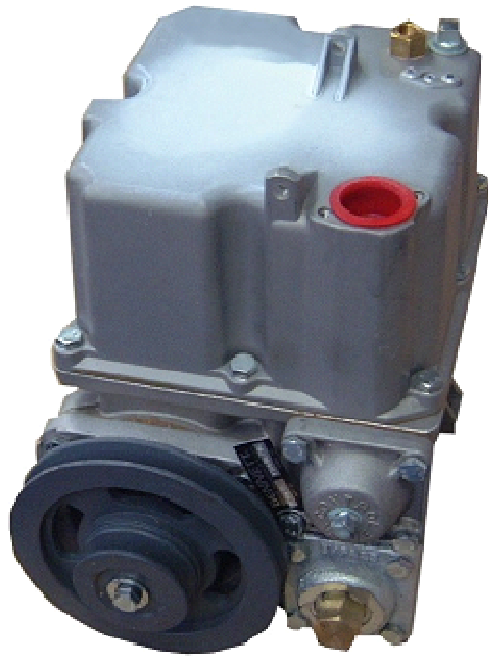


**Figure 3** **Analogue Solenoid Valve**



**Figure 4** **GPU 140 global pumping unit and integrated air separator**





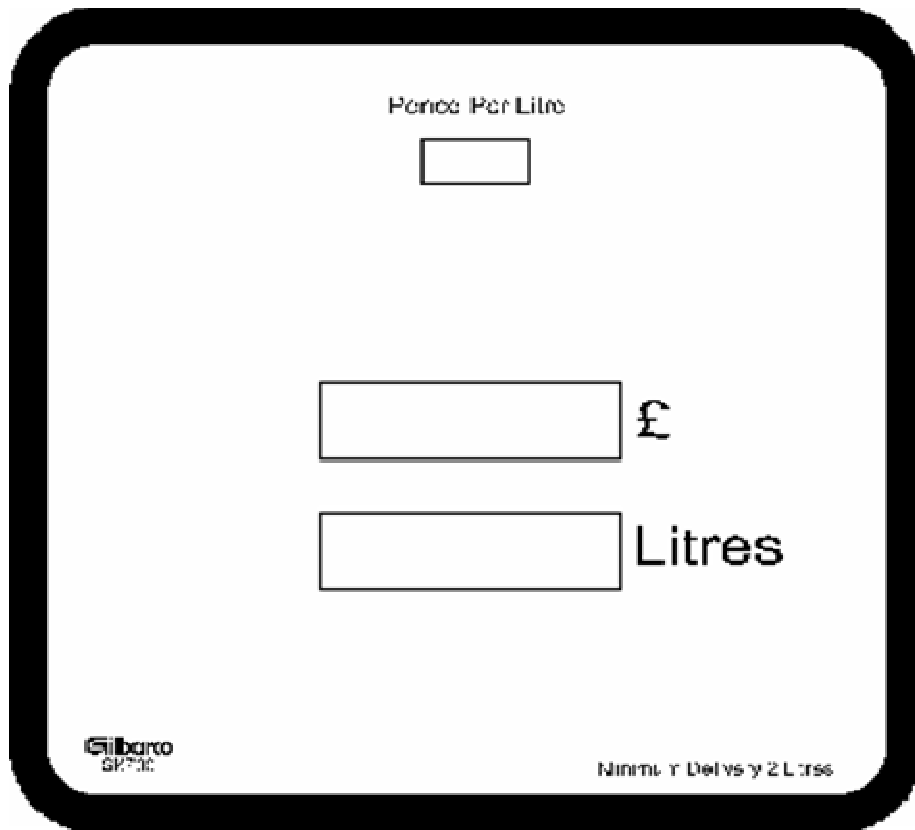
**Figure 5a GPU-90 Pumping Unit**



**Figure 5b GPU-90 Pumping Unit Sealing**



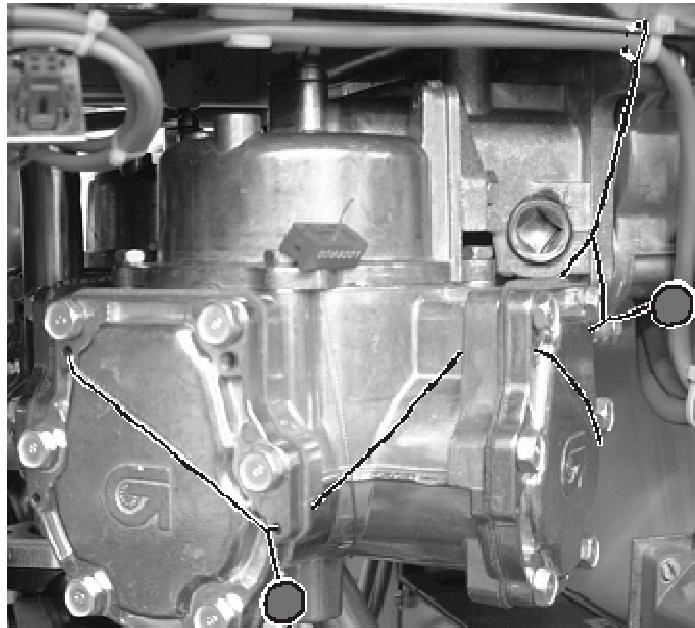
**Figure 6 SK700 sealing arrangement**



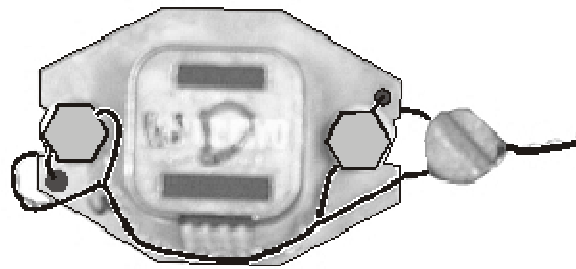
**Figure 7** Typical Dialface Legends



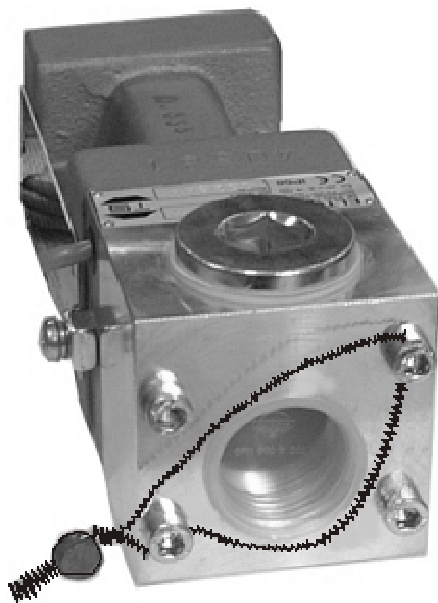
**Figure 8.** Pump Control Node Sealing



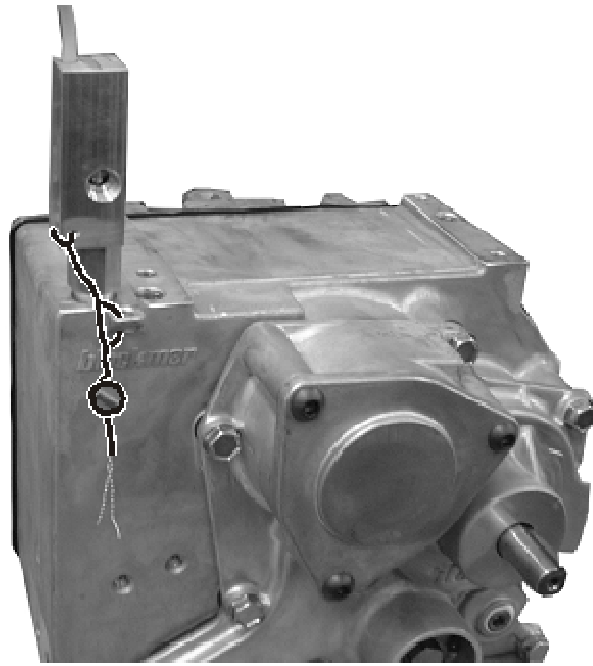
**Figure 9 C+ Meter Sealing**



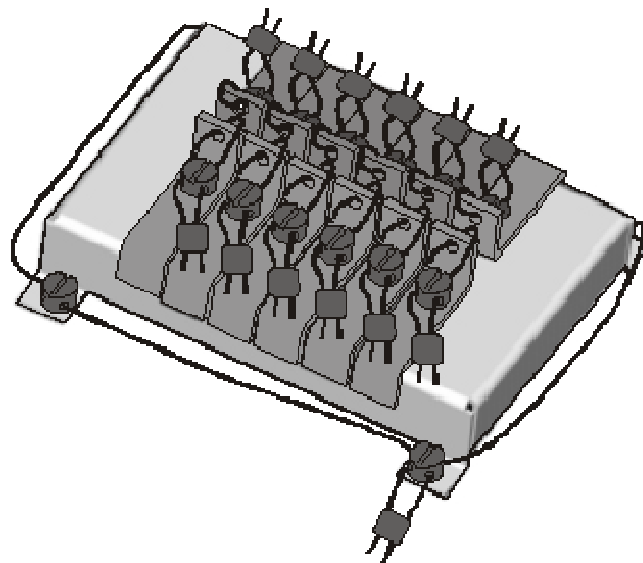
**Figure 10 C+ Meter Pulsar Sealing**



**Figure 11 Ecometer Pulsar & Meter Sealing**



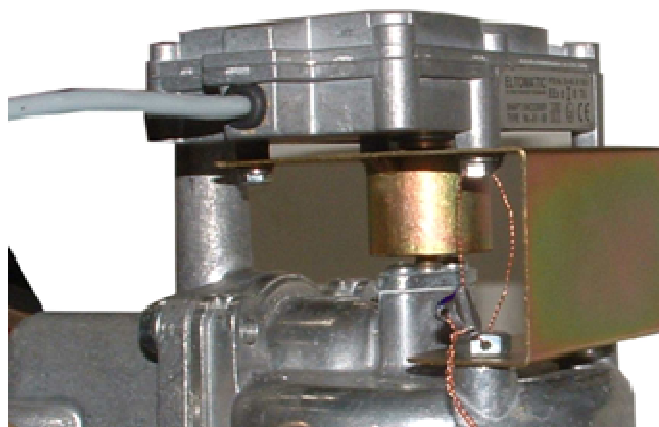
**Figure 12** Monobloc Gas Switch Sealing



**Figure 13** ECAL Board Sealing



**Figure 14** General view of Encore 510 dispenser



**Figure 15** Encore 510 pulser securing



**Figure 16** General View of Encore 500G



**Figure 17** Typical Computer Head Door with Infoscreen. (Encore 500G)

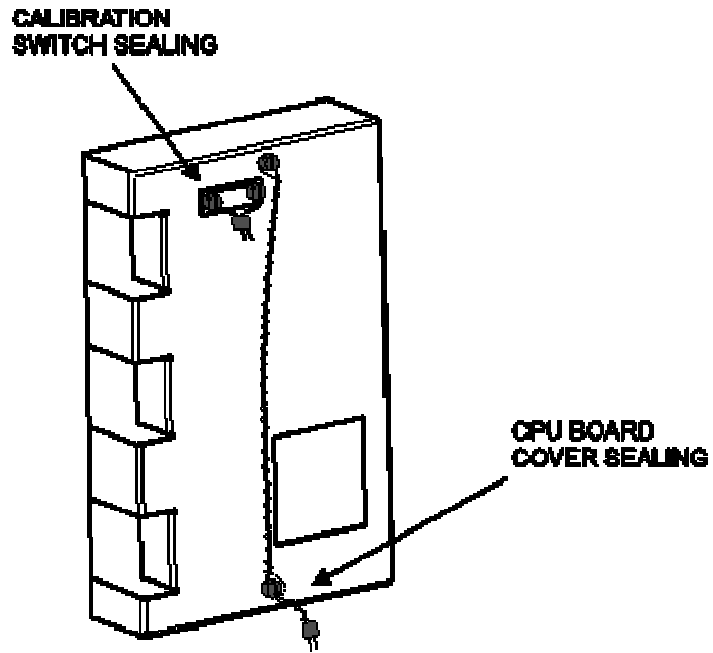


Figure 18 Sandpiper 2 - CPU board securing (sealing)

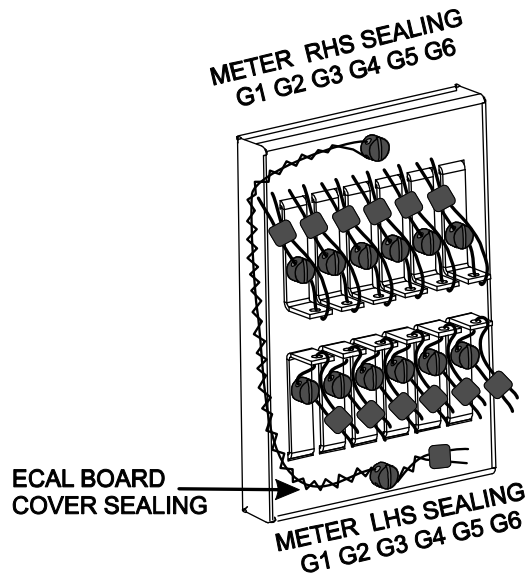


Figure 19 Sandpiper 2 - ECAL board securing (sealing)

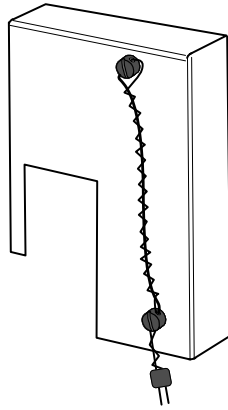


Figure 20 Sandpiper 2 - IS interface board securing (sealing)

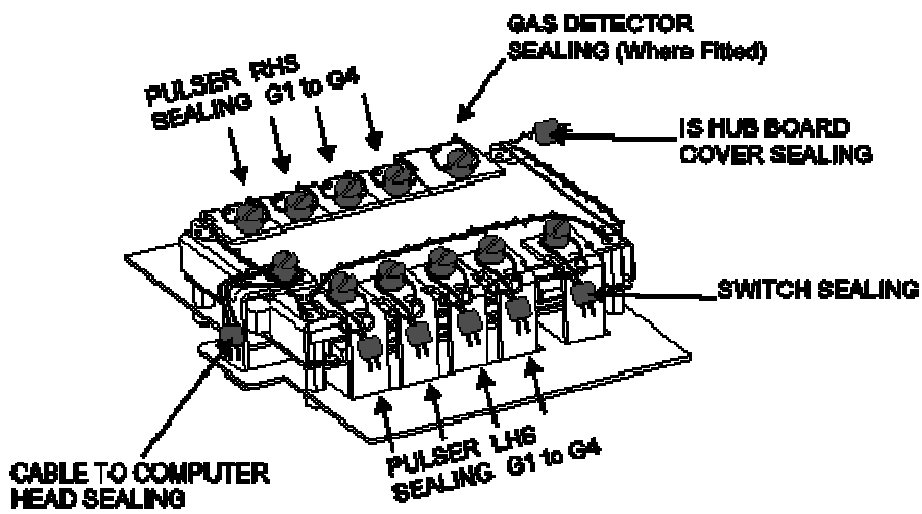


Figure 21 Sandpiper 2 - IS hub securing (sealing)

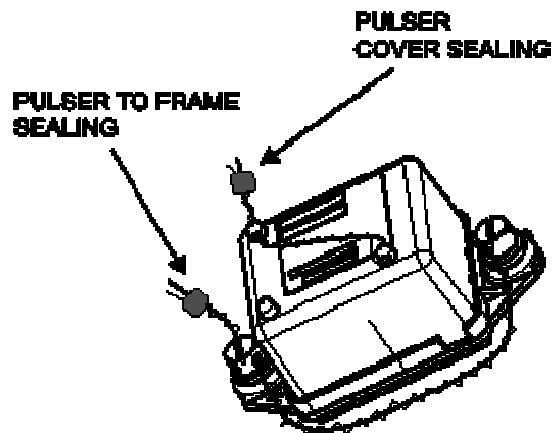
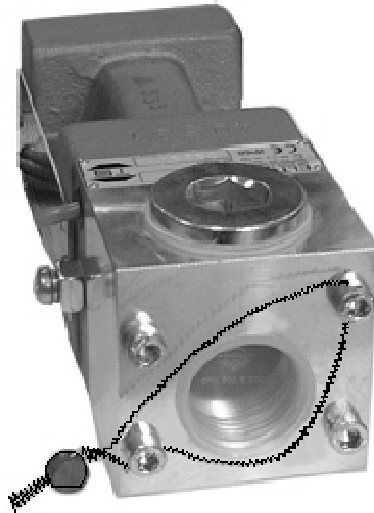
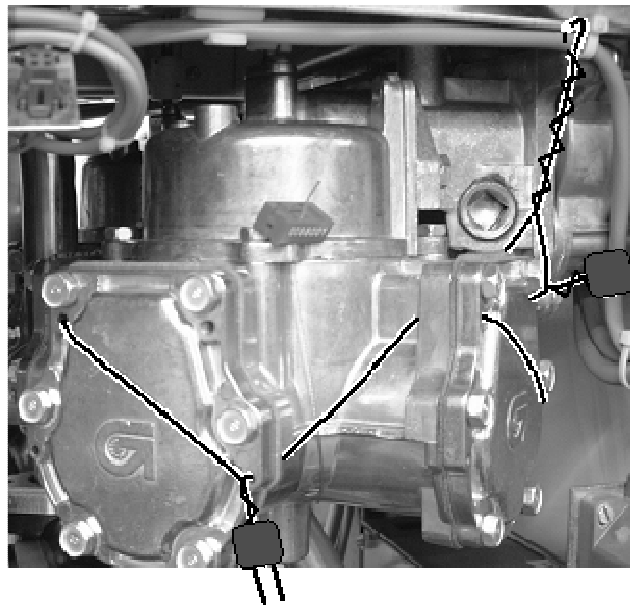


Figure 22 Sandpiper 2 - C+ pulser securing (sealing)





**Figure 23 Sandpiper 2 - Ecometer securing (sealing)**



**Figure 24 Sandpiper 2 - C+ Meter securing (sealing)**

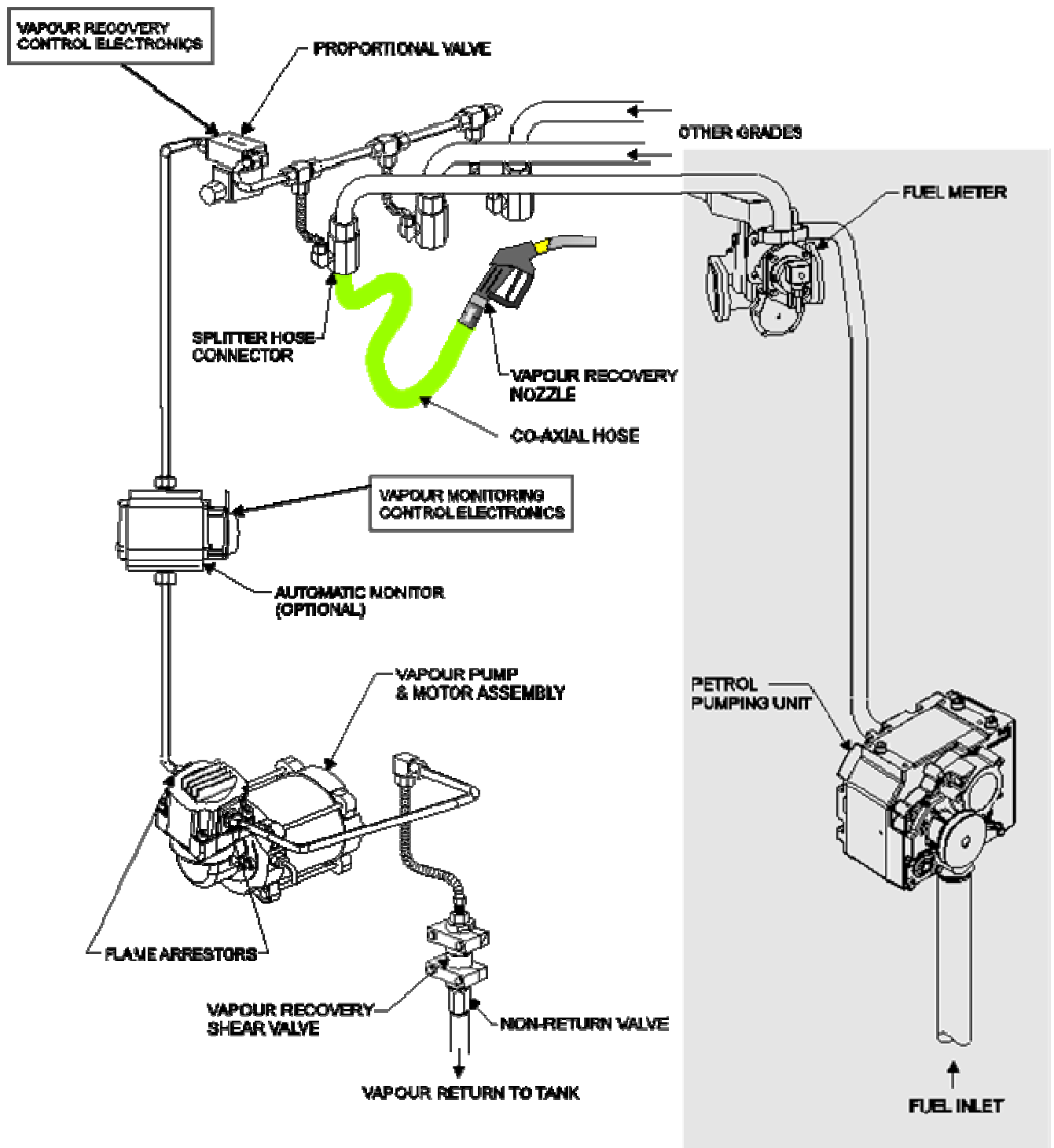
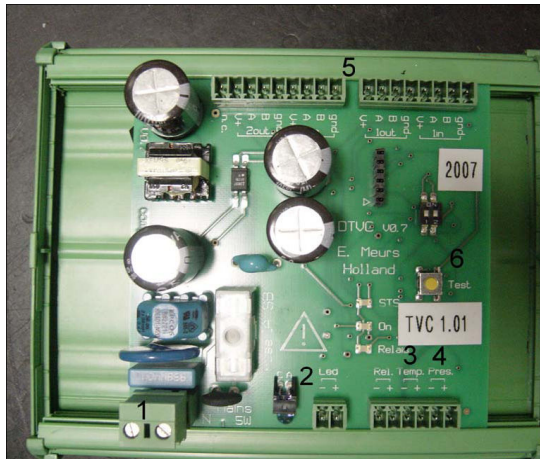
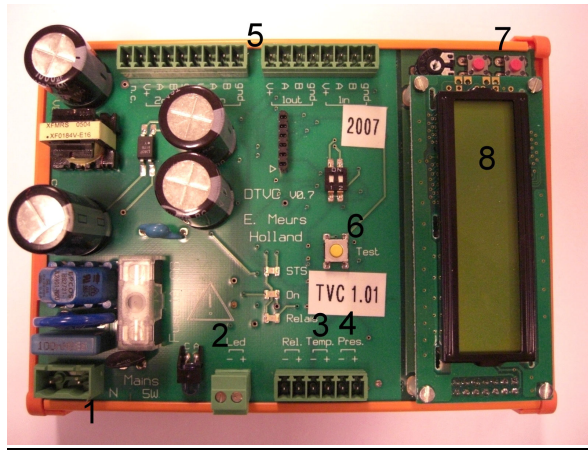


Figure 25 Typical vapour recovery system  
(Non-vapour recovery components shown within greyed area)



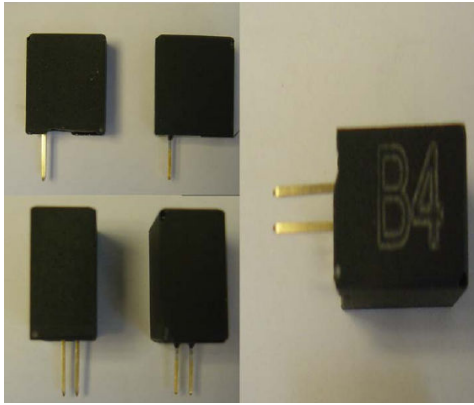
- 1 Power Supply connection 230V
- 2 Infrared Port for Data communication
- 3 Temperature sensor connection
- 4 Density block connection
- 5 Pulser channel connection
- 6 Calibration button TVC system on/off

**Figure 26** TVC unit without LCD display



- 1 Power Supply connection 230V
- 2 Infrared Port for Data communication
- 3 Temperature sensor connection
- 4 Density block connection
- 5 Pulser channel connection and Calculator connection
- 6 Calibration button TVC system on/off
- 7 Scroll function for display information
- 8 Display

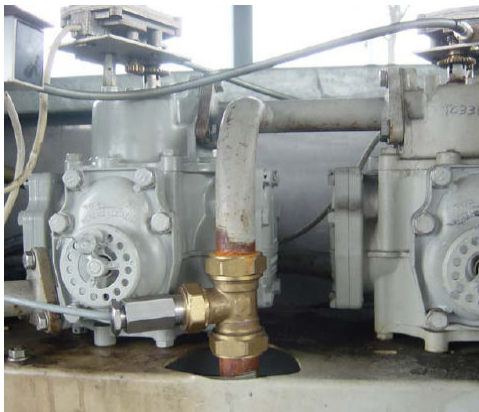
**Figure 27** TVC unit with LCD display



**Figure 28 Density blocks**



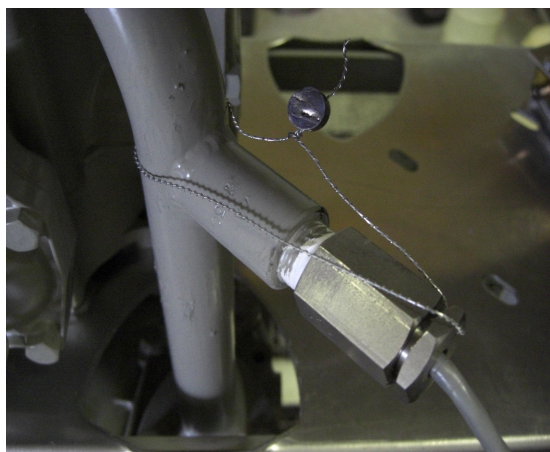
**Figure 29 Temperature sensor: LM335**



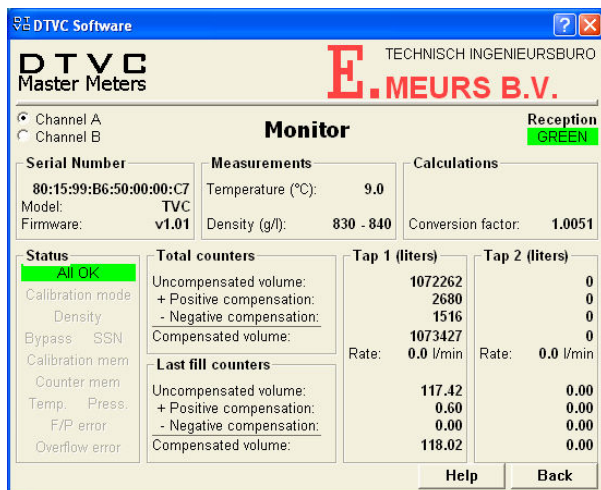
**30 Typical installation of temperature sensor**



**Figure 31 TVC unit sealing arrangement**



**Figure 32 Typical installation of temperature sensor and sealing arrangement**



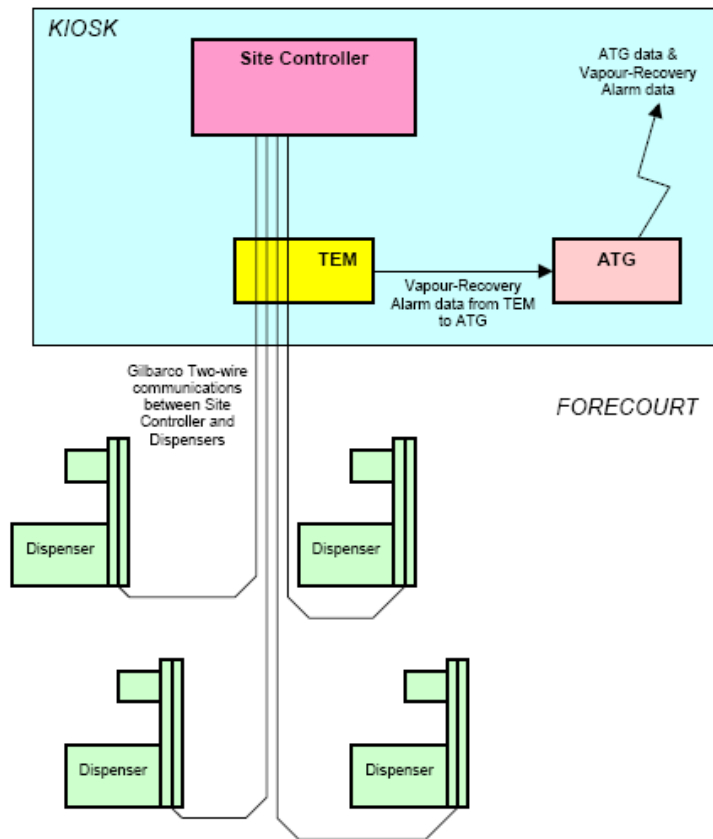
**Figure 33 Typical display of measurement data using 'Fuel Monitor' software**



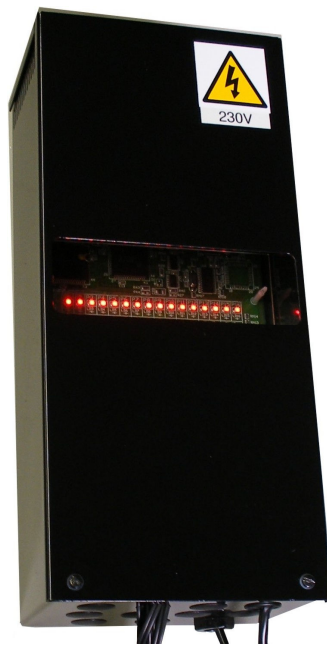
**Figure 34** Typical Single Hose Dispenser



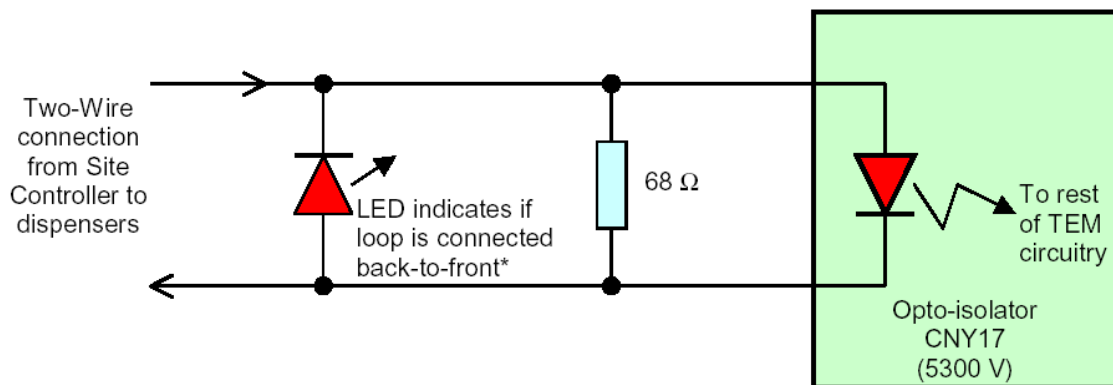
**Figure 35** Typical 2 Hose Dispenser



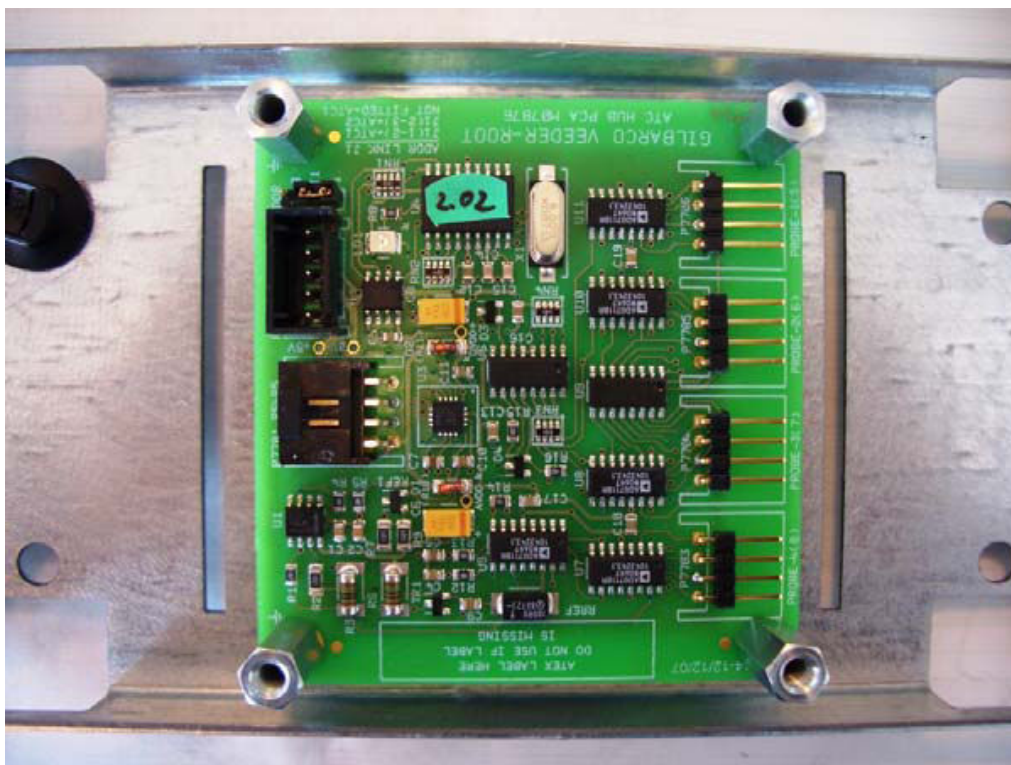
**Figure 36 Forecourt System Diagram showing TEM**



**Figure 37 TEM Module**

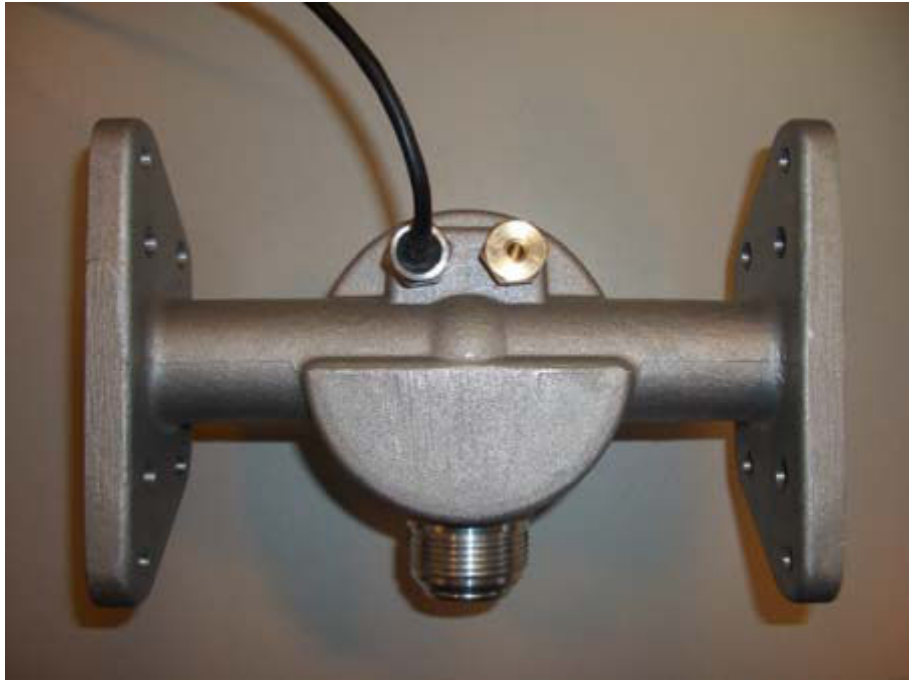


**Figure 38 TEM Block Diagram**



**Figure 39 ATC Hub Board**

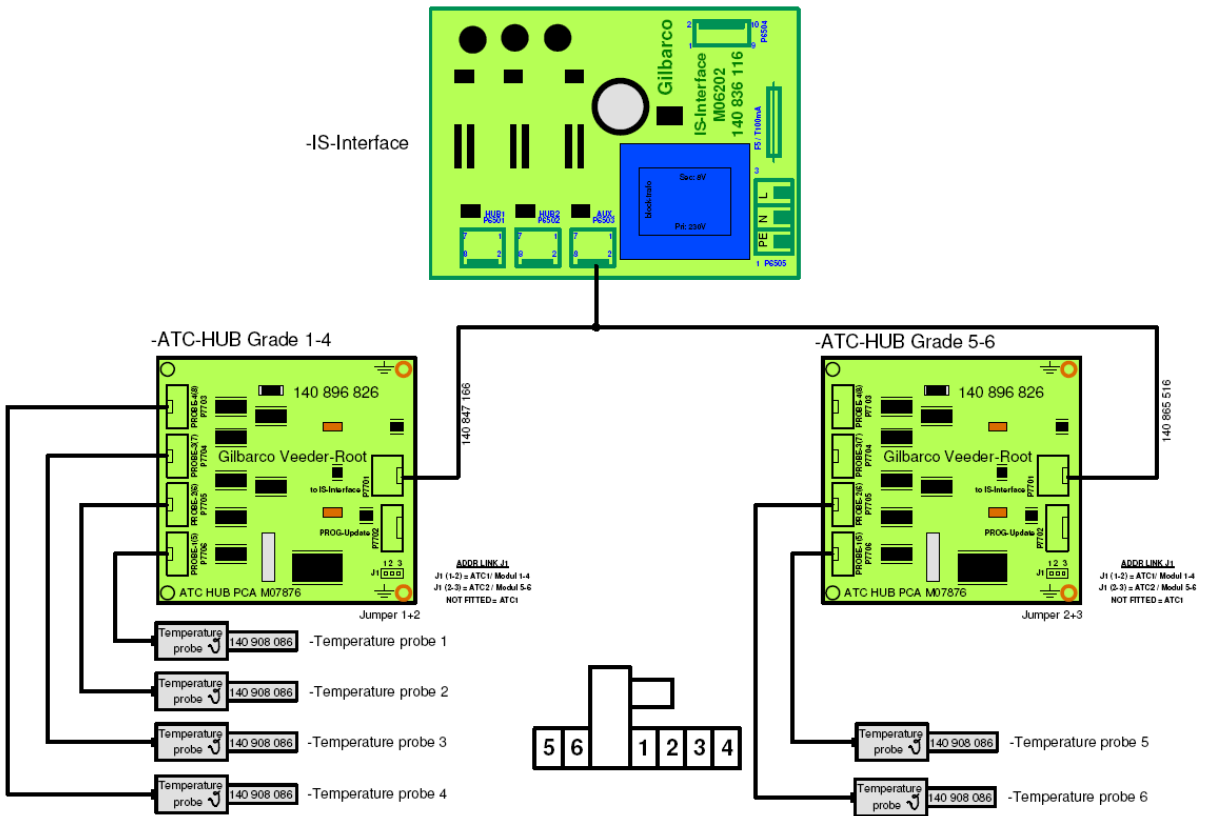




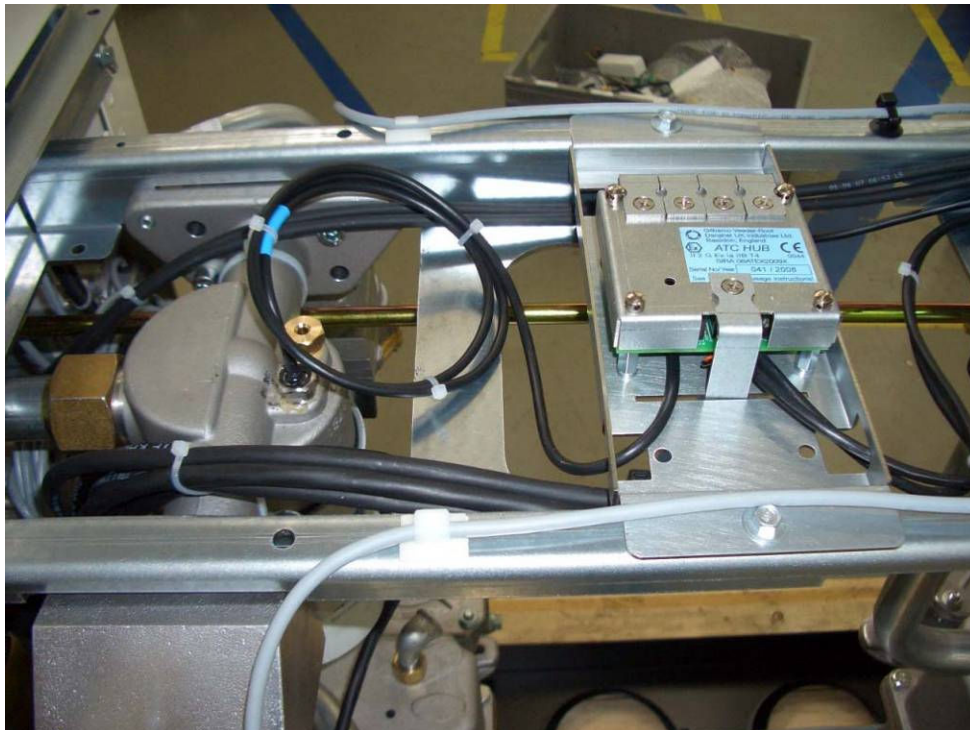
**Figure 40** ATC Manifold showing temperature sensor and test sleeve



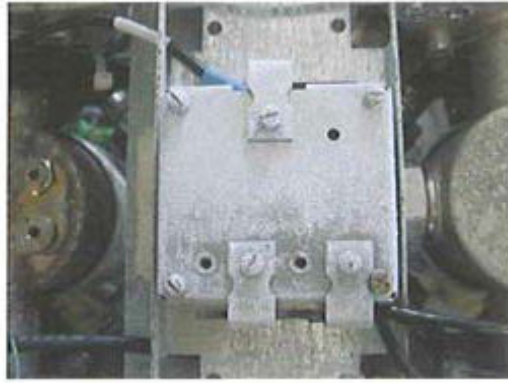
**Figure 41** ATC Temperature Sensor



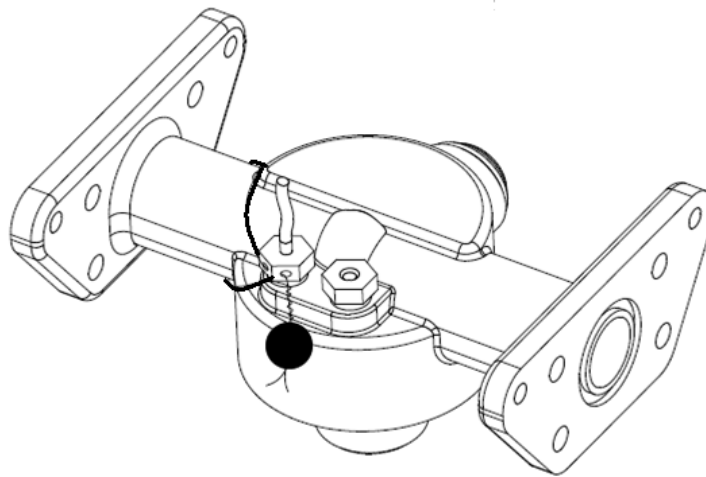
**Figure 42 ATC Hub Connections**



**Figure 43 ATC Hub mounted on hydraulic section supporting rail**



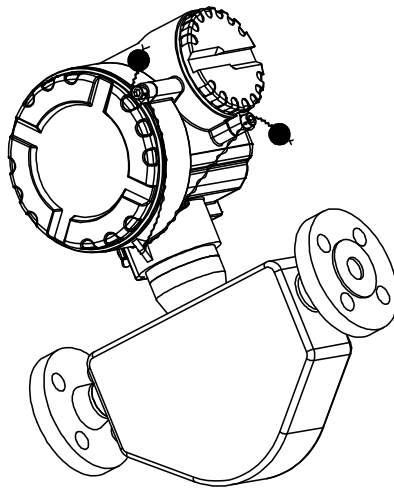
**Figure 44 ATC Hub Sealing**



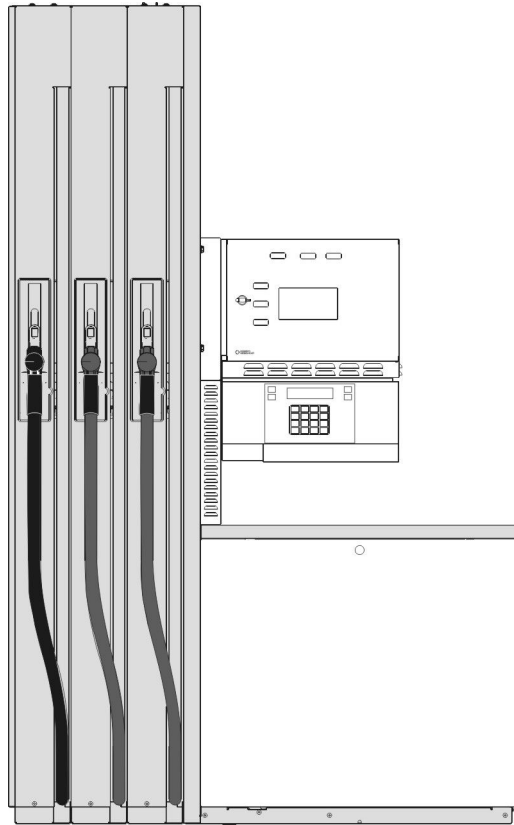
**Figure 45 ATC Temperature Sensor Sealing**



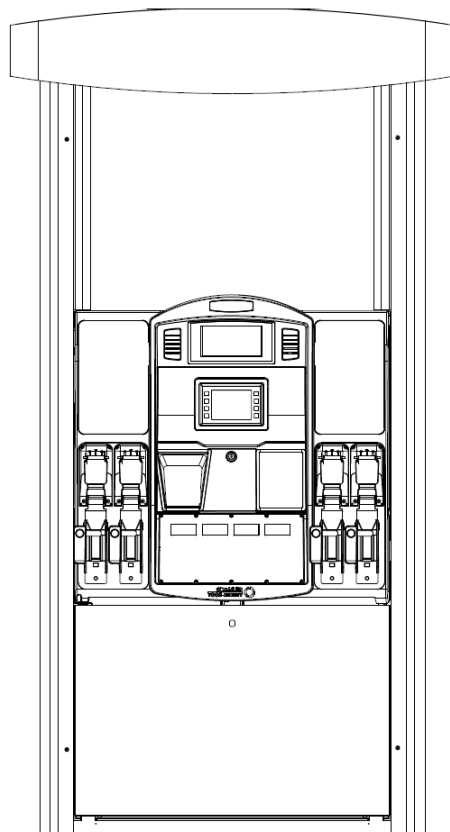
**Figure 46** Nordic Lane Dispenser RHS



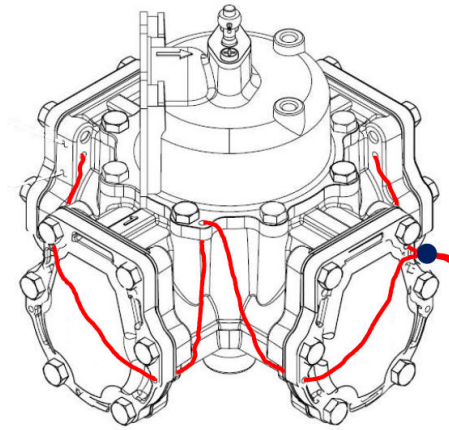
**Figure 47** Coriolis Meter Sealing



**Figure 48** Taller Hose Cabinet SK700



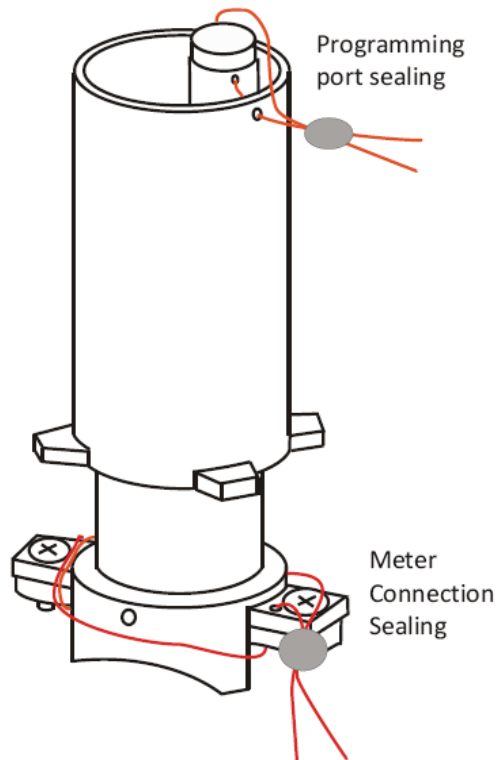
**Figure 49** Horizon Dispenser



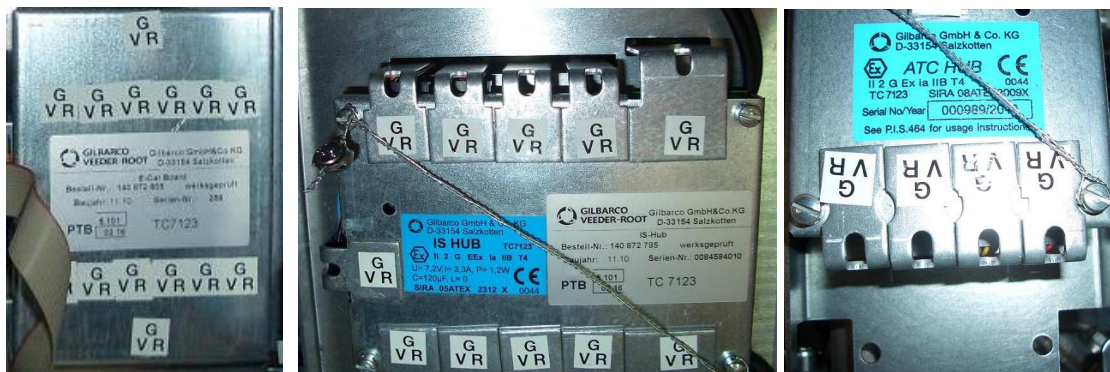
**Figure 50** V meter sealing example



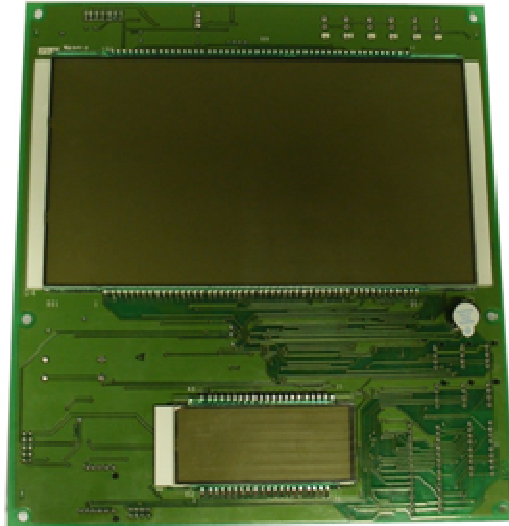
**Figure 51** Horizon Dispenser with integrated Spot M3



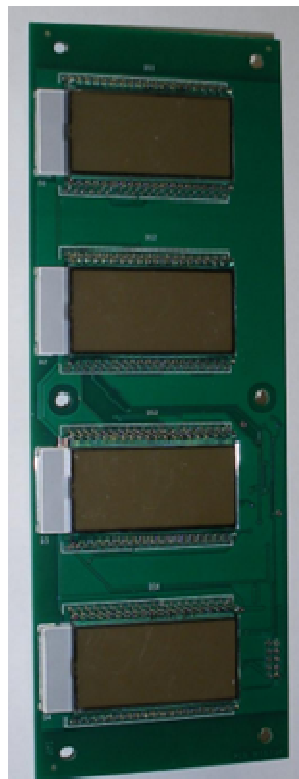
**Figure 52 Typical Secure Intelligent Pulser (SIP) sealing**



**Figure 53 Alternative Sealing – Tamper evident sticker seals**



**Figure 54** Combined Amount, Volume and Price per Unit Display



**Figure 55** Multiple Price per Unit Display





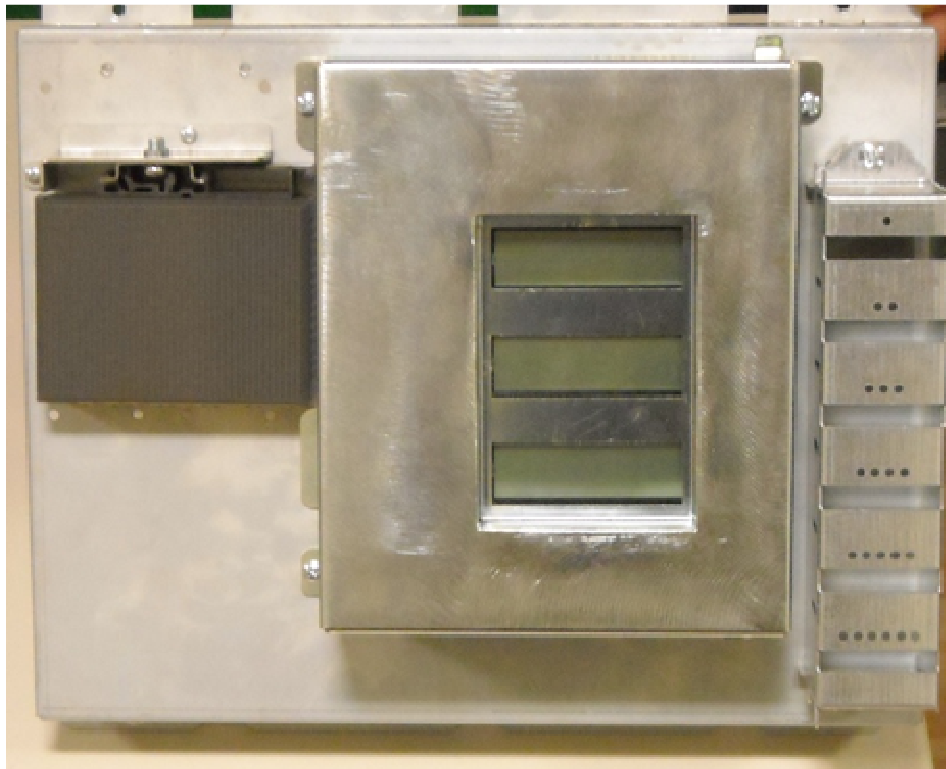
**Figure 56**     **Horizon Dispenser with Hose Retraction**



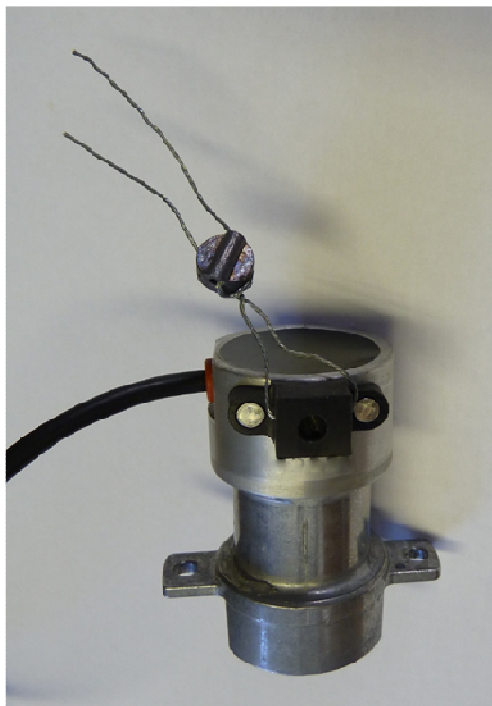
**Figure 57**     **Fafnir Vapour Monitor**



**Figure 58** DIMP Multimedia Display – typical display arrangement



**Figure 59** Internal display for DIMP Multimedia Display



**Figure 60** Typical Secure Intelligent Pulser (SIP) sealing – shorter body version



**Figure 61** 397G Dispenser