



# 2012 consultation on changes to the Building Regulations in England

## **Section one**

Introduction to the consultation package and proposals on  
Parts A, B, C, K, M and N, Access Statements, security,  
Changing Places toilets and Regulation 7



# 2012 consultation on changes to the Building Regulations in England

## **Section one**

Introduction to the consultation package and proposals on  
Parts A, B, C, K, M and N, Access Statements, security,  
Changing Places toilets and Regulation 7

© Crown copyright 2012

You may re-use this information (not including logos) free of charge in any format or medium, under the terms of the Open Government Licence. To view this licence, visit <http://www.nationalarchives.gov.uk/doc/open-government-licence/> or write to the Information Policy Team, The National Archives, Kew, London TW9 4DU, or e-mail: [psi@nationalarchives.gsi.gov.uk](mailto:psi@nationalarchives.gsi.gov.uk).

This document/publication is also available on our website at [www.communities.gov.uk](http://www.communities.gov.uk)

If you require this publication in an alternative format please email:  
[alternativeformats@communities.gsi.gov.uk](mailto:alternativeformats@communities.gsi.gov.uk)

Any enquiries regarding this document/publication should be sent to us at:

Department for Communities and Local Government  
Eland House  
Bressenden Place  
London  
SW1E 5DU  
Telephone: 030 3444 0000

January 2012

ISBN: 978-1-4098-3317-8

# Summary form

## Scope of the consultation

<b>Topic and scope of this consultation:</b>	<p>The Building Regulations and the associated statutory guidance set out in Approved Documents seek to ensure buildings meet certain standards for minimum health, safety, welfare, convenience and sustainability.</p> <p>This document is one of four sections of a consultation that covers a number of proposed changes to the Building Regulations regime and the building control system.</p> <p>This section covers proposals relating to Eurocodes, fire safety, radon, Access Statements, rationalisation of Parts M, K and N, domestic security, Changing Places toilets and the Approved Document supporting Regulation 7.</p>
<b>Geographic scope:</b>	<p>This consultation relates to Building Regulations for England only. The previous application of Building Regulations to England and Wales ceased on 31 December 2011 when powers for making Building Regulations in relation to Wales were transferred to the Welsh Ministers.</p>
<b>Impact Assessment:</b>	<p>Six Impact Assessments have been produced to accompany the proposals contained in Chapters 2 to 6. Chapters 7 and 8 do not relate to regulatory changes and Impact Assessments are therefore not necessary. No Assessment has been produced for the proposals in Chapter 9 as these are changes necessary as a consequence of other regulations (for which an Impact Assessment has already been produced). The other three sections to this consultation package are also accompanied by their own Impact Assessments.</p>
<b>IA Number</b>	<p>Part A (Eurocodes) – DCLG/0076  Part B – DCLG/0083  Local Acts – DCLG/0037  Part C (Radon) – DCLG/0077  Rationalisation of Parts M, K and N – DCLG/0078  Access Statements – DCLG/0079</p>

## Basic consultation information

<b>To:</b>	<p>This consultation is aimed primarily at firms, individuals and their representative bodies within construction and construction-related industries and the building control bodies that enable the building control system to operate. Specific elements may be of interest to members of the public.</p> <p>The Department has published an easier to read summary of the proposals which provides a useful introduction to the consultation package and highlights those aspects of the consultation which may be of interest to consumers. This is available at:</p> <p><a href="http://www.communities.gov.uk/planningandbuilding/buildingregulations/buildingregulationschanges/">www.communities.gov.uk/planningandbuilding/buildingregulations/buildingregulationschanges/</a></p>
<b>Body/bodies responsible for the consultation:</b>	The Building Regulations and Standards Division within the Department for Communities and Local Government.
<b>Opening date:</b>	31 January 2012
<b>Closing date:</b>	27 April 2012
<b>Enquiries about the subject being consulted on or the policy being considered:</b>	<p>Email to:</p> <p><a href="mailto:building.regulations@communities.gsi.gov.uk">building.regulations@communities.gsi.gov.uk</a></p> <p>or write to:</p> <p>Building Regulations Consultation          Building Regulations and Standards Division          Department for Communities and Local Government          Zone 5/G9          Eland House          Bressenden Place          London SW1E 5DU</p>

<p><b>How to respond to this consultation:</b></p>	<p>A response form for section one of the consultation is provided at Annex J of this document. It has also been published separately as part of the consultation package on the Department's website at:</p> <p><a href="http://www.communities.gov.uk/publications/planningandbuilding/brconsultationsection1">www.communities.gov.uk/publications/planningandbuilding/brconsultationsection1</a></p> <p>Consultees are invited to email responses to:</p> <p><a href="mailto:building.regulations@communities.gsi.gov.uk">building.regulations@communities.gsi.gov.uk</a></p> <p>Those who prefer to submit a paper copy of their response should send these to:</p> <p>Building Regulations Consultation  Building Regulations and Standards Division  Department for Communities and Local Government  Zone 5/G9  Eland House  Bressenden Place  London SW1E 5DU</p>
<p><b>Additional ways to become involved:</b></p>	<p>The Department will continue to engage with external partners throughout the consultation period and beyond on the range of consultation proposals. In particular, we will seek out opportunities presented by our partners to engage with relevant sectors on specific issues at relevant industry events around the country. The views of the public are also welcomed.</p> <p>If you require this publication in an alternative format please email:</p> <p><a href="mailto:alternativeformats@communities.gsi.gov.uk">alternativeformats@communities.gsi.gov.uk</a></p>
<p><b>After the consultation:</b></p>	<p>The Department will consider the responses to the consultation and finalise regulatory proposals. We will also publish a summary of responses on the Department's website, in line with the consultation protocols.</p> <p>The general aim is for deregulatory changes to come into force in April 2013 with provisions which have a regulatory impact coming into force in October 2013.</p>
<p><b>Compliance with the Code of Practice on Consultation:</b></p>	<p>This consultation complies with the Government's Code of Practice on consultation, which can be downloaded from:</p> <p><a href="http://www.bis.gov.uk/policies/bre/consultation-guidance">www.bis.gov.uk/policies/bre/consultation-guidance</a></p>

<p><b>How to complain or make a comment about the process of this consultation and/or whether it adhered to the Code of Practice on Consultation:</b></p>	<p>Should you want to raise any issues in this respect, you should write to:</p> <p>Consultation Co-ordinator  Department for Communities and Local Government  Zone 4/H3  Eland House  Bressenden Place  London SW1E 5DU</p> <p>or email:  <a href="mailto:ConsultationCoordinator@communities.gsi.gov.uk">ConsultationCoordinator@communities.gsi.gov.uk</a></p>
---	--

## Background

<p><b>Getting to this stage:</b></p>	<p>In July 2010 we invited external partners to submit ideas and evidence on ways to improve the Building Regulations, on reducing the regulatory burdens and on ways to deliver even better levels of compliance. We received several hundred responses which we used, along with contributions gathered at seminars and workshops, in developing a programme of work to examine a number of areas of the regulations. In December 2010 the Building Regulations Minister, Andrew Stunell, announced a programme of work to develop proposals for consultation in advance of changes in 2013.</p> <p>This document is one of four sections of a consultation on proposed changes to the building control system and to the technical aspects of the Building Regulations which are the result of that work. The consultation package is largely deregulatory in nature.</p>
<p><b>Previous engagement:</b></p>	<p>Through 2011 we have continued to work with a variety of external partners including the Building Regulations Advisory Committee, Working Parties and Advisory Groups to develop detailed proposals for consultation.</p>

# Contents

Summary of the consultation, scope and background	3
Code of practice on consultation, freedom of information and data protection	9
Chapter 1: Introduction to the consultation package	11
Chapter 2: Amendments to Part A (Structure)	19
Chapter 3: Amendments to Part B (Fire safety) and changes to the Local Acts	30
Chapter 4: Amendments to Part C (Site preparation and resistance to contaminants and moisture)	37
Chapter 5: Amendments to Parts K, M and N (Protection from falling, collision and impact, Access and Glazing), and new style for Approved Documents	42
Chapter 6: Amendments to guidance on Access Statements in Part M (Access to and use of buildings)	46
Chapter 7: Domestic security	53
Chapter 8: Changing Places toilets	58
Chapter 9: Amendments to the Approved Document supporting Regulation 7 (Materials and workmanship)	62
Annex A: Overview of the regulatory costs and benefits associated with the consultation proposals	66
Annex B: Equality Impact Assessment Initial Screening of the 2010 Building Regulations	70
Annex C: Equality Impact Assessment – Access Statements	74
Annex D: Equality Impact Assessment – Changing Places	81
Annex E: Proposed amendments to Approved Document A	87
Annex F: Draft Statutory Instrument to repeal Local Acts provisions	116
Annex G: Proposed amendments to Approved Document C	121



Annex H:	Proposed amendments to Approved Document M	124
Annex I:	Draft Approved Document to support Regulation 7 (materials and workmanship)	131
Annex J:	Response form for Section 1	157

# Code of Practice on Consultation, freedom of information and data protection

## Code of Practice on Consultation

The Code of Practice on Consultation is issued by the Better Regulation Executive (BRE) in the Department for Business, Innovation and Skills (BIS). The Code sets out seven consultation criteria, to which formal public consultation must adhere:

1. Formal consultation should take place at a stage when there is scope to influence the policy outcome.
2. Consultations should normally last for at least 12 weeks with consideration given to longer timescales where feasible and sensible.
3. Consultation documents should be clear about the consultation process, what is being proposed, the scope to influence and the expected costs and benefits of the proposals.
4. Consultation exercises should be designed to be accessible to, and clearly targeted at, those people the exercise is intended to reach.
5. Keeping the burden of consultation to a minimum is essential if consultations are to be effective and if consultees' buy-in to the process is to be obtained.
6. Consultation responses should be analysed carefully and clear feedback should be provided to participants following the consultation.
7. Officials running consultations should seek guidance on how to run an effective consultation exercise and share what they have learned from the experience.

Where this consultation paper does not adhere to the Code, it will be explained in the Consultation Profile.

Your opinions are valuable to us. Thank you for taking the time to read this document and respond.

If this is a formal, written, public consultation, are you satisfied that this consultation has followed these criteria? If not or you have any other observations about how we can improve the process please write to:

DCLG Consultation Co-ordinator  
Zone 4/H3  
Eland House  
Bressenden Place  
London SW1E 5 DU

or email:

ConsultationCoordinator@communities.gsi.gov.uk

## Freedom of information and data protection applicable to consultation

Representative groups are asked to give a summary of the people and organisations they represent, and where relevant who else they have consulted in reaching their conclusions when they respond.

Information provided in response to this consultation, including personal information, may be published or disclosed in accordance with the access to information regimes (these being primarily the Freedom of Information Act 2000 (FOIA), the Data Protection Act 1998 (DPA) and the Environmental Information Regulations 2004).

If you want the information that you provide to be treated as confidential, please be aware that, under the FOIA, there is a statutory Code of Practice with which public authorities must comply and which deals, amongst other things, with obligations of confidence. In view of this it would be helpful if you could explain to us why you regard the information you have provided as confidential. If we receive a request for disclosure of the information we will take full account of your explanation, but we cannot give an assurance that confidentiality can be maintained in all circumstances. An automatic confidentiality disclaimer generated by your IT system will not, of itself, be regarded as binding on the Department.

The Department for Communities and Local Government will process your personal data in accordance with DPA and in the majority of circumstances this will mean that your personal data will not be disclosed to third parties. Individual responses will not be acknowledged unless specifically requested.

# Chapter 1

## Introduction to the consultation package

### Background

1. Building Regulations control certain types of building work, principally the erection and extension of buildings and provision or extension of certain services or fittings, chiefly to ensure that buildings meet certain standards of health, safety, welfare convenience and sustainability.
2. Compliance with the Building Regulations is the responsibility of the person carrying out the work and the building control system helps to ensure that the required level of performance has been met. The role of a building control body, either the Local Authority or a private sector Approved Inspector, is to act as an independent third-party check to help achieve compliance. As an alternative to third-party checking by building control, some types of work may be self-certified as being compliant by installers who are registered as a member of a competent person self-certification scheme and have been assessed as competent to do so.
3. Building Regulations greatly influence how our buildings are constructed and used. As such, they help to deliver significant benefits to society. Regulation though can also impose costs on both businesses and individuals. The “functional” nature of the Building Regulations seeks to minimise this cost and also, by having regulation setting out what the broad requirement is rather than prescribing how compliance must be achieved, to ensure innovation is not hindered. Guidance in the Approved Documents that accompany the regulations then sets out some of the ways that these requirements can be met. This approach provides clarity for building control bodies and industry alike.
4. To avoid the risk of unnecessarily onerous and costly standards being imposed on industry it is important that a proper cost/benefit assessment and consultation with industry has been undertaken by Government to assess what reasonable minimum standards are appropriate.
5. It is also important to ensure that the Building Regulations regime remains current and fit-for-purpose. That is why the Department for Communities and Local Government (DCLG) undertook an exercise in the latter half of 2010 to determine what changes were necessary to the Building Regulations. The exercise emphasised a desire to identify measures that would reduce the cost of regulation to business. It

also asked for evidence and ideas about what other “must do” regulatory changes there were, as well as seeking ideas as to how we might deliver even better levels of compliance in the future. There were 248 individual responses from external partners to this exercise (as well as several hundred responses as part of a campaign for inclusion in the regulations of provision of Changing Places toilets). In addition, we drew upon ideas and suggestions submitted to the Cabinet Office’s *Your Freedom*<sup>1</sup> and DCLG’s own *Cut red tape*<sup>2</sup> websites plus other reviews and sources of evidence.

6. Few responses questioned the principle of regulations setting national standards that ensure buildings are built to baseline standards. Many specifically recognised the positive role Building Regulations played and welcomed the fact that there was a nationally applied set of minimum requirements. However, the exercise did suggest that there were areas where aspects of the regime might be streamlined to reduce the burden on business and others, where compliance might be improved yet further or where there was a strong case for considering further regulation. In the light of the ideas submitted, Building Regulations Minister, Andrew Stunell, set out in December 2010 the areas of work that would be taken forward in advance of consultation on detailed proposals.

## The consultation package

7. This document is one of four sections of a consultation package that now sets out those detailed proposals. On 31 December 2011 responsibility for the Building Regulations for Wales transferred to Welsh Ministers. Proposals in these consultations, therefore, relate to England only.
8. The four sections are:
  - Section one – Parts A, B (including Local Acts), C, K, M and N, Access Statements, security, Changing Places toilets and Regulation 7
  - Section two – Part L (Conservation of fuel and power)
  - Section three – Part P (Electrical safety – dwellings)
  - Section four – the building control system.

These can be found at:

[www.communities.gov.uk/planningandbuilding/buildingregulations/buildingregulationschanges/](http://www.communities.gov.uk/planningandbuilding/buildingregulations/buildingregulationschanges/)

<sup>1</sup> [webarchive.nationalarchives.gov.uk/20100824180635/http://yourfreedom.hmg.gov.uk/](http://webarchive.nationalarchives.gov.uk/20100824180635/http://yourfreedom.hmg.gov.uk/)

<sup>2</sup> [www.communities.gov.uk/localgovernment/about/helpcutredtape/](http://www.communities.gov.uk/localgovernment/about/helpcutredtape/)

9. Alongside this consultation document we have published six Impact Assessments to cover the proposals set out in chapters 2 to 6 and which are available at:

[www.communities.gov.uk/publications/planningandbuilding/brconsultationsection1](http://www.communities.gov.uk/publications/planningandbuilding/brconsultationsection1)

10. Similarly, Impact Assessments have been produced to support the proposals set out in the other three consultation documents. As stated above, we were particularly keen to explore the opportunity to deliver deregulatory savings as part of this review and **Annex A** provides an overview of the costs and benefits associated with the proposals in all four of the sections.
11. This package seeks to achieve a reasonable balance between regulatory “ins” and “outs”, in line with the Government’s commitments to reduce regulation and in particular to ensure that the regulatory burden on housebuilders is reduced by 2015. The Part L proposals in particular, if taken forward as proposed, will involve extra costs for house builders. The consultation package identifies some reductions in regulation to offset these, and we will ensure that other regulatory “outs” are identified at least to balance the “ins”, for example those secured by abolishing Home Information Packs, before changes are brought into effect.
12. The Government announced on 23rd March 2011 in ‘The Plan for Growth’ a commitment to exempt micro businesses and start-ups from new regulations introduced up to 2014. However, we think that there would be significant practical difficulties in exempting these firms from the changes proposed in this package. Many developments subject to Building Regulations involve businesses of various sizes working together. A situation where some businesses were subject to the changes, but others were not, would create confusion and complexity, potentially increasing the costs of compliance and working against achieving the deregulatory benefits we seek. We would therefore welcome your views on the applicability of the micro business moratorium to the proposals set out in this consultation.

### Question 1.1

Do you have any views as to the applicability of the micro business moratorium to these proposals?

13. As stated previously, the package contains a significant deregulatory element and the Department’s intention is that these changes will come into force in April 2013. For other regulatory changes, we currently intend that these will mainly come into force in October 2013 (with the exception of changes in Part L in relation to consequential improvements). Notwithstanding paragraph 12 above, the transitional arrangements that will accompany these changes will determine when and how these changes will actually impact on business. We therefore intend to use the period of consultation,

and beyond, to consider further the timing and transitional arrangements for bringing these proposals into effect, and how different approaches might reduce their impacts. We would welcome the views of consultees on this.

### Question 1.2

Should the timing of regulatory changes and/or transitional arrangements be changed to minimise the impact on business and, if so, how should this be done?

14. Government is committed to reviewing any changes it makes to regulations to establish if they are still the best way of achieving the objectives sought, whether they can be revoked or whether they can be modified to reduce burdens<sup>3</sup>. We therefore plan a five-year review of changes made after the coming into force of changes to the regime.
15. The Department carried out an equalities screening in 2010 on the Building Regulations current then to establish whether there were equalities issues that should be examined as proposals were developed for this consultation package. As a result of that screening the Department has also produced full Equality Impact Assessments on our proposals on Access Statements and Changing Places toilets. The reports on these are at **Annexes B, C and D** respectively.
16. Many consultees will be interested in only certain technical elements of the four sections. However, we would also draw to all consultees' attention and encourage responses in relation to:
  - Proposals contained in Chapter 9 of this document which proposes changes to the Approved Document supporting Regulation 7. This provides guidance in relation to materials and workmanship and thus will also be of interest to many consultees
  - Proposals on a new style for Approved Documents that are described in Chapter 5 and shown as an example in the draft version of Approved Document K (Protection from falling, collision and impact and glazing safety) provided alongside this consultation document at:  
[www.communities.gov.uk/publications/planningandbuilding/brconsultationsection1](http://www.communities.gov.uk/publications/planningandbuilding/brconsultationsection1)

<sup>3</sup> [www.bis.gov.uk/assets/biscore/better-regulation/docs/s/11-682-sunsetting-regulations-guidance](http://www.bis.gov.uk/assets/biscore/better-regulation/docs/s/11-682-sunsetting-regulations-guidance)

17. Respondents are asked to reply to this section of the consultation package using the response form at **Annex J**. This is available electronically at:

[www.communities.gov.uk/publications/planningandbuilding/brconsultationsection1](http://www.communities.gov.uk/publications/planningandbuilding/brconsultationsection1)

**Responses should reach the Department by 27 April 2012 and should preferably be submitted via e-mail to:**

[building.regulations@communities.gsi.gov.uk](mailto:building.regulations@communities.gsi.gov.uk)

## Development of these proposals

18. DCLG relies heavily on input and support from industry and other external partners in developing policy on changes to the Building Regulations. In spring 2011 we established with industry a number of working groups and advisory groups to offer views on emerging analysis and results and to provide advice on the developing consultation options. These groups provided additional support and advice to that obtained from experts on the Building Regulations Advisory Committee (BRAC). We are extremely grateful for the advice and assistance provided by the participants in these groups, and we look forward to working with them as we finalise proposals after we have received the consultation responses.

## Main issues covered in this consultation paper

### **Part A (Structure)**

19. The main changes proposed in Chapter 2 are replacement of the currently-referenced standards in Approved Document A guidance with the updated British Standards based on Eurocodes. Other more minor and generally related amendments are proposed, for example, in relation to disproportionate collapse and wind maps.

### **Part B (Fire safety) and the Local Acts**

20. Chapter 3 sets out two proposals intended to resolve practical problems in the application of Requirement B2 (Internal fire spread (linings)). Firstly, it is proposed to make a technical amendment to ensure wall coverings are not inadvertently and unnecessarily disadvantaged because of how certain wall coverings are assessed under the European classification system for fire performance. Secondly, in the light of evidence submitted to the Department, to amend the existing guidance in relation to lighting diffusers which is now believed to be unnecessarily onerous.
21. We are also taking this opportunity to confirm that we intend to take forward the repeal of the fire protection provisions in Local Acts and to seek the views of consultees on the draft statutory instrument that would achieve this.



### **Part C (Site preparation and resistance to contaminants and moisture)**

22. The main element of the proposals in Chapter 4 is an amendment to align the Approved Document C guidance with the most up-to-date radon maps, in effect, ensuring that the current safety provisions are targeted at the appropriate parts of the country. Other minor amendments to the Approved Document proposed include updating a number of referenced standards to reflect their replacement with British Standards based on Eurocodes.

### **Consolidating elements of Parts K, M and N (Protection from falling, collision and impact, Access and Glazing), and new style for Approved Documents**

23. The proposals contained in Chapter 5 seek to rationalise the inter-related guidance in these three Approved Documents. By rationalising the existing technical guidance these proposals seek to address areas of overlap and conflict and thereby provide cost savings for industry. They also provide an example of a new publishing style for Approved Documents.

### **Access Statements**

24. Chapter 6 contains proposals relating to guidance on the role of Access Statements in assisting with compliance with Part M (Access to and use of buildings). The proposals seek to promote a more risk-based approach to communicating compliance which is proportionate to the nature and complexity of the building work.

### **Security**

25. Chapter 7 explains the work that has been undertaken to understand whether there is a case to support regulating for a minimum standard of domestic security. In particular, it provides information on the analysis undertaken to establish the cost-effectiveness of security standards in homes and explains how we will take this work forward into the future.

### **Changing Places toilets**

26. Chapter 8 sets out the work the Department has done to consider whether Government intervention is necessary to increase the provision of Changing Places toilets. In the light of that, it considers the potential benefits in seeking to facilitate a collaborative approach between external partners to try and remove barriers and realise opportunities to deliver better levels of provision.

### **Regulation 7**

27. The proposals in Chapter 9 relate to changes to the Approved Document supporting Regulation 7 and are to clarify that Declarations of Performance and CE marking, as required under the EU Construction Products Regulation 2011, will become the main source of information on the performance characteristics of construction products from July 2013. We are also taking the opportunity to propose other minor changes to the Approved Document. No changes are proposed to Regulation 7 itself.

## Proposals not to be taken forward

28. The Ministerial announcement made in December 2010 set out the areas of work that would be considered in advance of public consultation on detailed proposals. However, work during this period has established that for a number of workstreams it would not be appropriate to take forward possible changes at this time. More information on these areas is set out below.

### **Part D (Toxic substances)**

29. Part D seeks to ensure toxic fumes from cavity wall insulation do not permeate into buildings. The Approved Document then outlines how this particularly applies to urea formaldehyde foam insulation.
30. We have examined the possibility of removing Part D, a revocation that would streamline the Building Regulations. However, we have established that urea formaldehyde foam insulation is still being installed in around 700 buildings a year and industry is looking to expand the use of this technology. We have no evidence that the health impact associated with formaldehyde in buildings has changed since Part D was first introduced.
31. We have concluded that there is a continuing need for the safeguards for the health of building occupants provided by Part D and we propose, therefore, not to change Part D or its Approved Document at this time.

### **Part E4 (Resistance to the passage of sound)**

32. This provision currently requires that schools are “suitable” acoustically. Guidance in the Approved Document then cross-refers to Department for Education (DfE) guidance. We committed to consider with DfE whether this provision was the most appropriate and effective way of achieving appropriate standards for school buildings.
33. Following the outcomes of the James Review, DfE will be consulting later this year on the acoustic design of schools. This will include proposed new guidance and any necessary changes to the provisions on acoustic standards in E4 of the Building Regulations.

### **Part H6 (Drainage and waste disposal)**

34. Part H6 currently requires the provision of adequate space for waste storage and suitable access arrangements. The statutory guidance in Approved Document H explains how compliance with this might be achieved and cross-refers to relevant legislation on waste collection.

35. As part of the announcement made in December 2010, we said that the existing national regulatory approach would be reviewed given the different local approaches to waste collection.
36. Localised waste management approaches continue to develop and Government more widely is working with key partners on future approaches to waste management, including collection frequencies, recycling and separate collection of food waste.
37. We recognise that the current Building Regulations approach provides a level of certainty. Alongside this there is also the potential that alternative approaches may become more suitable to the waste collection approaches of the future. We are not convinced that an amendment should be made until we are clearer on how waste management practices will develop over the coming years in light of the Government’s Waste Review, including its commitment to work with local authorities – through the planned Weekly Collections Support Scheme – to increase the frequency and quality of waste collections and to make it easier to recycle. We have concluded, therefore, that it would be premature to change the current approaches outlined in Approved Document H6. We will keep this provision under review and examine whether future changes would be appropriate to support waste collection practices and local choices, and to protect the health, safety and welfare of building users.

**Question 1.3**

Consultees are welcome to provide information on any of the points raised in Chapter one of this document. They can also take this opportunity to submit ideas and evidence that they would like us to take into account as we consider future approaches to the Building Regulations.

# Chapter 2

## Amendments to Part A (Structure)

### Background

38. The Department set out last December that it did not believe there was sufficient evidence to support a wholesale review of Part A. However, the Department did commit to looking at whether Approved Document A should be updated to reference the most recent British Standards based on Eurocodes. In addition, it recognised that there was some support for clarifying the guidance currently provided on disproportionate collapse and considering further whether there was merit in a scheme, similar to that already operating in Scotland, to allow for third-party certification of structural designs.
39. The Department has engaged a number of industry experts as it examined options and their helpful and valued contributions have informed the set of proposals discussed below and detailed at Annex E. The proposals on third-party certification for structural designs is being discussed as part of a wider consultation on third-party certification in the linked consultation on changes to the building control system which is available at:
- [www.communities.gov.uk/publications/planningandbuilding/brconsultationsection4](http://www.communities.gov.uk/publications/planningandbuilding/brconsultationsection4)
40. We are not proposing any changes to the Part A legislative provisions in the Building Regulations. Proposals to change the guidance in Approved Document A<sup>4</sup> will be made by amendment slip rather than by publishing a new Approved Document. Annex E sets out the amendments proposed, which are described below.

### Eurocodes

41. The development of Eurocodes, a pan-European harmonised approach to structural design, has been promoted and supported by the European Commission over many decades to remove barriers to trade and services created by the different national design approaches that existed across Europe. The Commission has outlined expectations that EU Member States will support this harmonisation and market liberalisation by ensuring national regulations refer to standards based upon the Eurocodes.

<sup>4</sup> Approved Document A: Structure. 2004 edition incorporating 2004 amendments. Available at [www.planningportal.gov.uk/uploads/br/BR\\_PDF\\_AD\\_A\\_2004.pdf](http://www.planningportal.gov.uk/uploads/br/BR_PDF_AD_A_2004.pdf)

42. The technical work to develop these standards has been led by the European standards body CEN and has involved the national standards bodies of Europe, including the British Standards Institution (BSi) for the UK. These organisations set a timetable and, in line with this, on 1 April 2010 BSi replaced their standards dealing with structural design to reflect the approach incorporated in the Eurocodes and withdrew the previous nationally-based ones. Approved Document A currently makes extensive reference to the withdrawn British Standards when providing guidance on what is a reasonable level of structural safety in design. These withdrawn standards are no longer being technically maintained by BSi and existing guidance is at risk, therefore, of becoming increasingly out of date with time.
43. In addition, there is a risk that the UK could face legal challenge from the European Commission if it were not to align the current references in the Approved Document to those British Standards based upon Eurocodes. This would be a particular problem beyond 2015 when the withdrawn standards are likely to be considered sufficiently outdated by the passage of time and any public policy justification for retaining references would be extremely difficult to maintain.
44. We therefore propose to replace the current references to these withdrawn standards with references to the new British Standards based on Eurocodes and the relevant UK National Annexes. Alongside these we propose also to include a number of references to BSi Published Documents (PD's) where these provide designers with essential and other informative advice.
45. Annex E shows where these references will change throughout Approved Document A. This includes a replacement of Section 1 of Approved Document A that lists codes, standards and other references for structural design. Annex E also shows where we propose to change references to supporting standards such as BS8103 "Structural design of low-rise buildings" series of standards which have already been amended as Eurocodes compatible.

### **Question 2.1**

Do you agree that the structural design standards currently referenced in Approved Document A should be replaced by the Eurocodes-based British Standards with their National Annexes as proposed? Please explain why if you do not.

**Question 2.2**

It is generally accepted that use of the Eurocodes-based British Standards with their National Annexes and non-conflicting complementary information provides at least an equivalent level of safety and serviceability to the withdrawn British Standards currently referenced. Do you have evidence that this is not the case?

**Question 2.3**

We believe that our approach in Annex E to referencing BSi Published Documents provides essential and helpful additional information in support of Eurocodes implementation. Do you agree (and if not which, if any, are essential to include)?

## Implementation of Eurocodes changes

46. The proposed changes to Approved Document A are intended to come into force in 2013. As the Impact Assessment accompanying this consultation document recognises, there are one-off, transitional costs to business associated with a move to a structural design approach based on the Eurocodes. A proportion of industry has already incurred this cost wholly or to some extent. However, a significant proportion of industry has not and Government accepts that many of the firms that might potentially be impacted upon are smaller businesses.
47. It is important to remember, however, that the proposed Eurocodes-related changes affect only the guidance contained in the Approved Document and not the functional requirements contained in the Building Regulations themselves. Further, the functional nature of the Building Regulations means that this guidance does not necessarily need to be followed, that is, alternative approaches may well be acceptable, subject to them being shown to satisfy the functional requirements of the Regulations.
48. In order to ensure this flexibility of approach is properly understood by business and building control bodies, we therefore propose to supplement guidance in the Approved Document with additional advice, perhaps through an accompanying Circular with the final changes, that clarifies:
  - that until withdrawn British Standards become significantly outdated, probably some time after 2015, use of currently-referenced structural design standards could still be used to demonstrate compliance with the Building Regulations

- that beyond 2015 use of these withdrawn standards may in some circumstances still be acceptable and that building control bodies should accept an approach where a designer is able to demonstrate it is appropriate for the particular building structure proposed. This is likely to be particularly appropriate for smaller-scale building development.
49. This will assist business, and small firms in particular, in two ways. Firstly, it will provide at least an additional two years for firms to prepare for, and spread the costs over, the switch to a regime based on Eurocodes-based structural design. Secondly, it will also allow certain types of firm, principally those very small firms whose work is made up of smaller-scale buildings in the domestic sector, to continue to use the currently referenced withdrawn British Standards, thereby avoiding the additional costs associated with a switch to Eurocodes-based British Standards.

#### **Question 2.4**

Do you agree that additional guidance should be provided in a Circular, or similar, to clarify how currently referenced and withdrawn British Standards might continue to be used up to and beyond 2015?

## Impact Assessment

50. In the Impact Assessment that accompanies these proposals we have set out the costs of moving to a system based on Eurocodes. Our initial work suggests that these costs are one-off associated with the transition to a new system rather than ongoing ones. In particular, we believe that overall there are no additional costs of constructing buildings designed using standards based on Eurocodes, but we would welcome evidence in support of this assumption.

#### **Question 2.5**

Do you agree that the actual cost of constructing buildings using standards based on Eurocodes are neutral overall and what evidence do you have to support or refute this?

51. The transitional costs in the Impact Assessment are dependent on the estimates and assumptions set out in that document. We would welcome the views of consultees on this assessment and in particular on the following assumptions/costs:
- costs/savings associated with the cost of construction are on the whole neutral
  - the estimates on the individual elements of the cost on firms – in particular software, other design aids, productivity and familiarisation costs

- that large firms would mainly have incurred the costs of moving to Eurocodes voluntarily
- that the make-up of those firms that will incur additional cost is 80:20 in favour of the smallest firms
- the number of firms that will not move over to Eurocodes within the 2015 timescale or at all
- that approximately a half of firms that will have purchased Eurocodes have yet to incur 75% of their costs.

### Question 2.6

Do you agree with the estimated transitional costs? If not, please identify which assumptions/estimates you disagree with and, if possible, provide evidence to support your response.

52. Paragraphs 58 to 60 of the Impact Assessment address the potential benefits of moving towards a design approach based on Eurocodes. We would welcome the views and any available evidence that would support better understanding of the benefits to industry and others of moving to referencing Eurocodes in Approved Document A.

### Question 2.7

Do you have any further information to support or refute the assessment of the benefits associated with referencing the Eurocodes-based standards in Approved Document A?

## Other Eurocodes-related changes

53. We are bringing forward for consultation a number of other Eurocodes-related changes, in addition to updating the standards references, to ensure consistency in the Approved Document A guidance.
54. Section 2 of the Approved Document contains guidance for stability and sizing of structural elements for certain residential buildings and other small buildings of traditional construction. This guidance includes information on how wind loads impact on the building height. We propose to amend the wind map provided in Diagram 6 in Approved Document A and the associated calculation approach outlined in Diagram 7 that can be used to establish maximum allowable building heights.



55. The main changes, as shown in Annex E, reflect and align the diagram with the Eurocodes-based British Standards structural design approach. In addition, we are minded to introduce the alternative approach, shown as a new Figure 3 to Diagram 6. This would introduce a graphical option for determining the orography Factor O that is used in establishing maximum allowable building height. This is believed to provide economy of design for sites where orography is a significant factor, without affecting safety.

### Question 2.8

Do you agree that the changes proposed to Diagram 6 and the calculation procedure in Diagram 7 provide equivalent safety to the current guidance?

### Question 2.9

Do you agree the new optional procedure for determining Factor O given in Diagram 6, Figure 3 provides equivalent safety and economy of design?

56. We propose also to amend the guidance on cavity wall ties in Approved Document A. The revised Table 5, shown in Annex E, has obsolescent references removed with BS EN 845-1 becoming the principal reference product specification standard. We propose also to make corresponding changes to the guidance on wall ties and spacing in cavity walls in 2C8 and 2C19. We believe this is consistent with current product specification standards and the Eurocodes-based design approach.
57. The following section outlines proposals in relation to Approved Document A guidance on robustness and disproportionate collapse. Some of these are Eurocodes related. Others are brought forward following the work we have done since we set out last December that we would be examining improvements in this guidance.

## Robustness and disproportionate collapse

58. We are also bringing forward a number of proposals to amend the guidance in Section 5 of Approved Document A on robustness and disproportionate collapse, to reflect the implementation of a design approach based upon Eurocodes. These are shown in Annex E.
59. We propose to update the British Standards references in paragraph 5.2 of the Approved Document with references to BS EN 1990, BS EN 1991-1-7 and the relevant materials-based Eurocodes structural design Standards. Alongside this we also propose to amend the existing Table 11 Building classes on page 41 of Approved

Document A to make its classification terminologies consistent and compatible with Eurocode-based British Standards.

60. In addition, we also propose to change the Approved Document guidance, in paragraph 5.3, on design for key elements to align it with supporting Eurocodes-based British Standards. This provides a compatibility of design approach.
61. We are minded to amend Diagram 24 which shows tolerable limits on the area of collapse for accidental events as shown in Annex E. This would align it with the guidance in BS EN 1991-1-7 "General actions – Accidental actions". It has been suggested that this, which would extend the area of collapse to 100m<sup>2</sup> from the current 70m<sup>2</sup> does not represent a significant increase in safety risk over the current guidance, given the evolution in modern buildings design which tends to larger grid dimensions, particularly for framed building structures.
62. We also propose to include additional guidance in relation to seismic design, shown in Annex E as a new paragraph 5.5 for Approved Document A. This reflects the introduction of Eurocode 8 (BS EN 1998) for seismic design as a part of the Eurocodes suite of standards, but clarifies how and where designers might and might not need to consider this.
63. In addition to these Eurocodes-related changes to the guidance on robustness and disproportionate collapse, we are minded to modify the existing guidance to indicate that Consequence Class 2a and 2b buildings should additionally meet the robustness measures for Consequence Class 1 buildings (5.1c & 5.1d of Approved Document A). This provision has always been implied, but some external partners have suggested it would be useful to state it more clearly in guidance.
64. It has been suggested that it would be helpful to designers and not incompatible to include a reference in the Alternative approach guidance of Section 5 (specifically paragraph 5.4) to the recent design guidance published by the Institution of Structural Engineers which provides alternative recommendations on design for robustness and disproportionate collapse of building structures.

### **Question 2.10**

The changes proposed to Section 5 guidance, particularly in referencing Eurocodes-based British Standards for structural design, are intended to provide an equivalent level of safety and robustness to the current approach based upon withdrawn British standards. Do you agree?

### Question 2.11

Do you agree that changing the area limit in Diagram 24 from 70m<sup>2</sup> to 100m<sup>2</sup> to align guidance with BS EN 1991-1-7 “General actions – Accidental actions” introduces no significant additional risks?

### Question 2.12

Do you agree that it is helpful to include reference to the ISE Practical Guide to Structural Robustness and Disproportionate Collapse in Buildings as an Alternative approach reference?

65. In October 2011 the Department published a report of a review by Arup Consulting that had been commissioned under the previous administration in conjunction with the Centre for the Protection of National Infrastructure into international research on structural robustness and disproportionate collapse. This report is available for free download at:

[www.communities.gov.uk/publications/planningandbuilding/robustness](http://www.communities.gov.uk/publications/planningandbuilding/robustness)

66. Many of the report’s 28 recommendations are aimed at industry and education, but a number relate to Part A (Structure) and Approved Document A. Some of these recommendations coincide with proposals being brought forward as part of this current Building Regulations review. The proposals in this consultation on amendments to guidance in Section 5 which in effect accept recommendations are the:
- Proposed implementation for disproportionate collapse of Eurocodes-based British Standards for structural design
  - Proposed guidance that Consequence Class 2a and 2b buildings should additionally be provided with Consequence Class 1 buildings minimum robustness
  - Proposal to amend Diagram 24 so it describes 100m<sup>2</sup> as the tolerable area at risk of collapse in the event of an accident
  - Referencing of the Institution of Structural Engineers publication “Practical Guide to Structural Robustness and Disproportionate Collapse in Buildings (2010)” as optional alternative guidance procedures.
67. Additionally, the Department is supporting work proposed in the report and currently being undertaken by The Institution of Structural Engineers to develop a methodology and design guidance for Consequence Class 3 buildings which require a systematic risk assessment of structure to be undertaken.

68. Other report recommendations which are Part A-related are either less compelling or require further examination and we have not brought forward proposals in this consultation in response to these. However, we would welcome consultees providing evidence and data to assist our future examination of the report's recommendations.

## Other changes which are not Eurocodes related

69. Whilst other areas of Approved Document A guidance might benefit from updating, the focus of the current review is on deregulatory opportunities and essential changes only and we are, therefore, not undertaking a full revision of the Approved Document. However, there are a number of issues which, following discussions with external partners, we would like to explore during the current consultation and these are outlined below.
70. We propose to address a conflict between the guidance in Approved Document A and that in Approved Document K (Protection from falling, collision and impact) by amending paragraph 3.5 of Section 3 of Approved Document A, as shown in Annex E. This will bring the guidance on wall cladding functioning also as pedestrian guarding into line with that contained in Approved Document K.
71. We are minded to amend the guidance in paragraph 2E4 of Approved Document A on the minimum depth of strip foundations to reflect current industry practice. We would welcome views on amending the guidance to a three-tier graduated approach for minimum foundation depths in clay soils, as shown in Annex E.

### **Question 2.13**

Do you agree it would be a helpful change in line with industry practice to amend the guidance in Approved Document A (2E4) to a three-tier graduated approach for minimum foundation depths in clay soils?

72. It has been suggested that the Section 4 guidance relating to loading resulting from the re-covering of roofs should refer back to the original roof, to protect against possible cumulative changes in loading on buildings which have been re-roofed a number of times over the life of the building. Annex E shows a draft amendment that indicates that the acceptable change in loading should be measured against the loading of the roof as originally built. We would be interested in consultees' views on how common or significant this concern is in practice, and whether this is a practical or the best way to highlight this in what is general guidance.

73. It has also been suggested that it would be appropriate and helpful in certain situations if we defined the “significant” decreased loading in paragraph 4.7 as more than 15% from the original as-built condition, with regard to the potential risk due to roof uplift stability from wind loadings. We would welcome consultees’ views on this, particularly whether 15% is too high or too low.

## Freestanding and retaining boundary walls

74. A number of collapses of freestanding and retaining boundary walls occur each year, occasionally causing injury and, fortunately even more rarely, death. These collapses tend to arise from poor maintenance as well as design and construction inadequacies, often related to older walls.
75. There have been a number of interventions by Government and industry that encourage good construction and maintenance practice. These include:
- Guidance the Department has previously issued on boundary wall design, construction and maintenance – *“YOUR GARDEN WALLS – Better to be safe than sorry!”* – which can be downloaded for free from:  
[www.planningportal.gov.uk/buildingregulations/approveddocuments/parta/associateddocuments/gardenwall](http://www.planningportal.gov.uk/buildingregulations/approveddocuments/parta/associateddocuments/gardenwall)
  - Regulations made under the Health and Safety at Work etc Act 1974 which, amongst other things, requires that all practicable steps are taken to ensure the stability of any new or existing structures (for example, boundary walls) when carrying out construction work – although these requirements do not apply when domestic owner-occupiers carry out building work themselves
  - NHBC Technical Standards, which provide guidance for registered builders and which satisfy the requirements necessary to obtain Buildmark Warranty on newly constructed homes, make reference to relevant BRE guidance and to related standards for boundary walls.
76. In addition, local authorities have powers under the Building Act 1984 to take action to make dangerous structures safe, which may include boundary walls which become unsafe.

77. However, these types of walls are not currently addressed by the Building Regulations. In response to concerns about the incidents associated with boundary wall collapse, the Department has previously examined whether extending the Building Regulations to address the design and construction of boundary walls would be appropriate. To support this, the Department commissioned research by the Building Research Establishment into these collapses and the associated injuries and fatalities. This work also included an appraisal of the benefits and the costs that might arise if the scope of Building Regulations was extended.

78. The report of this is available on the DCLG web site alongside this consultation at:

[www.communities.gov.uk/publications/planningandbuilding/brconsultationsection1](http://www.communities.gov.uk/publications/planningandbuilding/brconsultationsection1)

This reached the conclusion that whilst extending Building Regulations might raise construction standards of new build boundary walls and provide an economic benefit for wall owners in terms of longer wall life and reduced maintenance costs, the additional regulatory costs would exceed the corresponding health and safety benefits obtained. The Department has therefore brought no proposals forwards to extend the Building Regulations to address the risks from boundary walls.

79. Although there are no plans to bring these walls under control through the Building Regulations, we will keep this issue and alternative approaches under review and would welcome contributions of evidence and analysis from consultees and their ideas on how good practice might further be promoted.

**Question 2.14**

Are you able to provide information to inform further consideration of any of the topics raised in or related to this consultation chapter, for example, in relation to freestanding walls or to loading increase and decrease associated with re-covering of roofs?

# Chapter 3

## Amendments to Part B (Fire safety) and changes to the Local Acts

### Background

80. Requirement B2 (Internal fire spread – linings) of the Building Regulations seeks to restrict the spread of flame and heat release rate of the products used in lining any partition, wall, ceiling or other internal structure. The guidance in Approved Document B sets reasonable standards by reference to both the European (EN) and British (BS) test and classification systems. The appropriate classification varies in the guidance depending on the location of the wall lining and either system of classification can be used. These design standards provide a baseline set of technical performance requirements for fire safety, but are not exclusive of other options being used to show compliance.
81. We are considering two amendments to the Approved Document intended to reduce any unnecessary burdens whilst ensuring that an adequate level of safety is maintained. These relate to the application of Requirement B2 to decorative wall coverings and for thermoplastic lighting diffusers.
82. In addition, this Chapter also confirms our intention to take forward the repeal of the fire protection provisions in the Local Acts.

### Decorative wall linings

83. The existing guidance in Approved Document B covering the application of Requirement B2 to wall linings does not clearly differentiate between decorative wall coverings and wall linings that form part of the construction. As a result there is uncertainty as to how decorative coverings should be addressed.
84. The guidance in Approved Document B sets reasonable standards by reference to both the European (EN) and British (BS) test and classification systems. The appropriate classification varies in the guidance depending on the location of the wall lining and either system of classification can be used.

85. At present most decorative wall coverings for use in non-domestic applications are rated as “Class O” under the British Standard classification system and would be acceptable for use in corridors and other circulation spaces. However, the same products tend to be rated as “Class C” or worse under the European classification system and, under the current guidance in Approved Document B, their use would not be permitted in those locations. This presents a technical disincentive to the use of the European System as currently acceptable products would need to be replaced or reformulated. This is a problem peculiar to thin wall coverings such as wall papers and does not manifest itself for other lining products subject to the same guidance.
86. We propose to append a new note to the existing table 10 Classification of linings in Approved Document B which will clarify the position and ensure that the use of the European classification system for reaction to fire does not present a disadvantage (see note 5 to Table 10 below).
87. We have commissioned research to test these proposals and the final report will be made available on the Department’s website at:  
  
[www.communities.gov.uk/publications/planningandbuilding/brconsultationsection1](http://www.communities.gov.uk/publications/planningandbuilding/brconsultationsection1)
88. It should be noted that the proposed amendments are not intended to reduce standards of safety and would not change the need or otherwise to apply the CE marking to products in accordance with the upcoming Construction Products Regulation. However, it is possible to mitigate some of the unintended consequences of imposing the European classifications by amending our own national provisions.



## Decorative wall coverings – proposed amendment to Table 10 of Approved Document B Volume 2

<b>Table 10 Classification of linings</b>		
<b>Location</b>	<b>National class <sup>(1)</sup></b>	<b>European class <sup>(1)(3)(4)</sup></b>
Small rooms (2) of area not more than: a. 4m <sup>2</sup> in residential accommodation b. 30m <sup>2</sup> in non-residential accommodation	3	D-s3, d2
Other rooms (2) (including garages)	1	C-s3, d2
Other circulation spaces, including the common areas of blocks of flats	0	B-s3, d2 <b>(5)</b>
<b>Notes:</b> 1. See paragraph B2.v. 2. For meaning of room, see definition in Appendix E. 3. The National classifications do not automatically equate with the equivalent classifications in the European column, therefore, products cannot typically assume a European class, unless they have been tested accordingly. 4. When a classification includes 's3, d2', this means that there is no limit set for smoke production and/or flaming droplets/particles. <b>5. This includes decorative wallcoverings which conform to BS EN 15102:2007 <i>Decorative wallcoverings – roll and panel form products, which achieve at least Class C-s3,d2 and are bonded to a Class A2-s3,d2 substrate.</i></b>		

### Question 3.1

Do you agree that the proposed amendments to Table 10 are reasonable and maintain the necessary standards of safety?

## Thermoplastic lighting diffusers

89. The existing guidance in Approved Document B covering the application of Requirement B2 to lighting diffusers was developed some time ago. Since then lighting technology has changed considerably and requirements for energy efficiency have become more stringent. At the time, it was designed to allow the use of diffuser products that could not be classified in the normal way due to their tendency to soften and fall out of the test apparatus. Products that can be classified in the normal way are not affected by these provisions.
90. The guidance separates thermoplastics into two groups, TPa and TPb. TPa materials tend to perform better in relation to fire spread than TPb materials and this is reflected in the restrictions that apply to their use. However, the most efficient diffusers tend to be manufactured using TPb materials. This presents a growing conflict between the provisions for fire safety and those for energy efficiency. The Lighting Industry Federation has asked us to look again at this guidance to see if this conflict can be resolved.

91. In support of this request, Zumtobel Lighting Ltd has provided a report by BRE Ltd which demonstrates that TPb materials can be used in more efficient layouts without adversely affecting fire safety.
92. We propose to insert a new row into the existing Table 11 in Approved Document B (supported by a new Diagram 28) which will provide spacing criteria for TPb diffusers which we believe will allow the lighting industry to deliver efficient lighting whilst maintaining a reasonable standard of fire safety (see the revised Table 11 below).

**Question 3.2**

Do you agree that the proposed amendments to Table 11 are reasonable and maintain necessary standards of safety?

**Question 3.3**

Do you think the proposed new Diagram 28 is necessary to illustrate the changes to Table 11?

## Lighting diffusers – proposed amendment to Table 11 of Approved Document B Volume 2

<b>Table 11 Limitations applied to thermoplastic rooflights and lighting diffusers in suspended ceilings and Class 3 plastic rooflights</b>				
<b>Minimum classification of lower surface</b>	<b>Use of space below the diffusers or rooflight</b>	<b>Maximum area of each diffuser panel or rooflight <sup>(1)</sup> (m<sup>2</sup>)</b>	<b>Max total area of diffuser panels and rooflights as percentage of floor area of the space in which the ceiling is located (%)</b>	<b>Minimum separation distance between diffuser panels or rooflights <sup>(1)</sup> (m)</b>
TP(a)	Any except protected stairway	No limit <sup>(2)</sup>	No limit	No limit
<b><u>D-s3, d2</u></b>  Class 3 <sup>(3)</sup>  or TP(b)	Rooms	<b>1</b>	<b>50</b> <sup>(4)(5)</sup>	<b>A distance equal to the largest plan dimension of the largest diffuser or roof light or</b>
		5	50 <sup>(4)(5)</sup>	3 <sup>(5)</sup>
	Circulation spaces except protected stairways	5	15 <sup>(4)</sup>	3
<b>Notes:</b>				
1. Smaller panels can be grouped together provided that the overall size of the group and the space between one group and any others satisfies the dimensions shown in Diagram 27.				
2. Lighting diffusers of TP(a) flexible rating should be restricted to panels of not more than 5m <sup>2</sup> each, see paragraph 6.16.				
3. There are no limits on Class 3 material in small rooms. See paragraph 6.1, Table 10.				
4. The minimum 3m separation specified in Diagram 27 between each panel <b>or group</b> must be maintained. Therefore, in some cases it may not also be possible to use the maximum percentage quoted.				
5. Class 3 rooflights to rooms in industrial and other non-residential purpose groups may be spaced 1800mm apart provided the rooflights are evenly distributed and do not exceed 20% of the area of the room.				
6. This table is not relevant to products which meet the provisions in Table 10.				

**Diagram 28** Layout restrictions on small Class 3 plastic rooflights, TP(b) rooflights and lighting diffusers

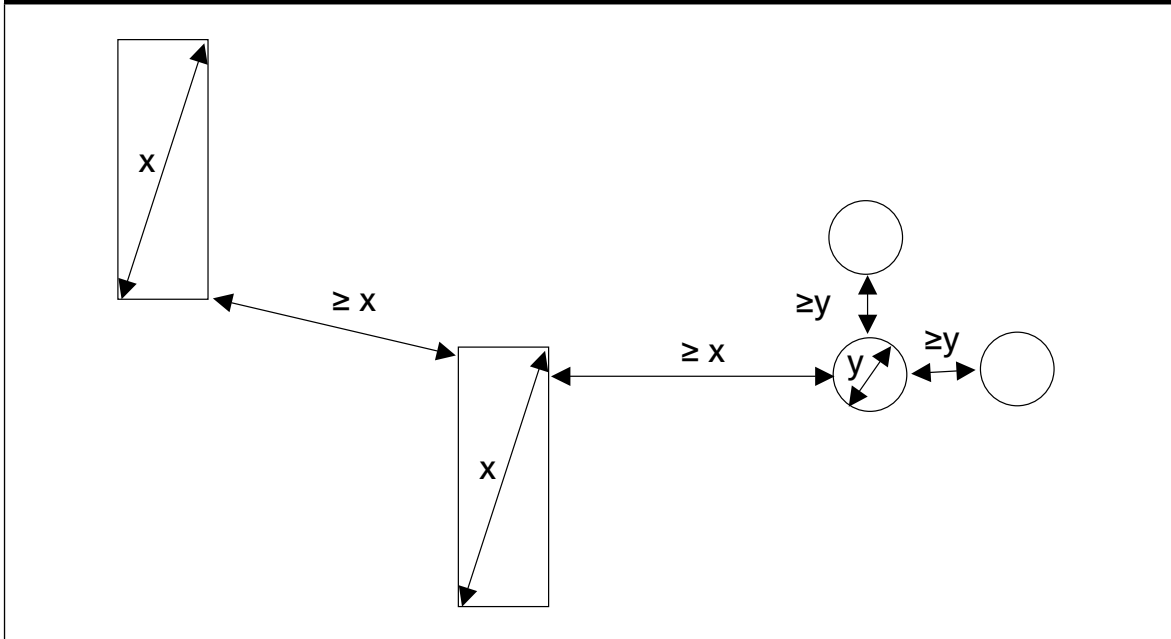

### Question 3.4

Are you able to provide information to inform further consideration of any of the topics raised in or related to this consultation chapter?

## Local Acts

93. Local Acts contain a wide range of miscellaneous provisions applying to a particular local authority area – dealing with such things as street trading, dog fouling, parks etc. Around 28 of them have one or more specific provisions for fire precautions which are in addition to national Building Regulations (for England and Wales) requirements and apply only in the area that the Act covers.
94. Whilst the fire protection provisions of the Acts vary, they tend to include provisions which give the local authority the discretion to impose additional requirements for fire protection which are more onerous than would be required in national building regulations for warehouses, car parks and tall buildings. In 2005 a study, commissioned by the Department, concluded that although there was evidence that these provisions had some effect on reducing property losses, they have no statistically significant impact on life safety. The final report from this study is available online at:

[www.bre.co.uk/filelibrary/pdf/rpts/partb/Local\\_Acts.PDF](http://www.bre.co.uk/filelibrary/pdf/rpts/partb/Local_Acts.PDF)

95. The Department wrote to interested groups on 18 August 2010 asking for comment on the proposed repeals. We received 45 responses of which 21 respondents supported the repeals and 17 objected, with the majority citing concerns for fire-fighter safety and/or property protection. A further 7 respondents were neutral or gave a mixed response. Supporters broadly felt that Local Acts imposed unnecessary bureaucratic and cost burdens on developers. Several local authorities supported repeal because they did not enforce the local Acts.
96. Some respondents suggested that Local Acts currently provided better protection for fire-fighters than is provided by the Building Regulations. However, no rationale was given as to why fire-fighters should be better protected in some areas than in the rest of the country. It was also suggested that Local Act provisions also contributed to reducing financial losses from fires. However, the Department does not consider this to be an appropriate objective for regulation as the management of business risks is a matter for the business community and their insurers
97. Large fires do result in the release of carbon dioxide and other damaging substances into the environment, but any environmental benefits from enhanced fire protection need to be balanced against the environmental damage of costs of manufacturing and installing fire protection systems. Recently published research by the Business Sprinkler Alliance has suggested that enhanced fire protection in some large warehouse buildings could bring an overall environmental benefit. Whilst this may well be true, this is not considered sufficient to justify retaining these provisions.
98. Having considered the responses to the 2010 consultation it has been decided to take the repeals forward. A draft statutory instrument setting out the repeals is at Annex F and the Department would be grateful if the affected local authorities would check the drafting of the order for accuracy.

# Chapter 4

## Amendments to Part C (Site preparation and resistance to contaminants and moisture)

### Background

99. We outlined last December that we would undertake work to consider further essential changes to the guidance in Approved Document C, particularly in relation to the introduction of British Standards based on Eurocodes and the revision of radon maps.
100. The Department has engaged a number of industry experts as it examined options and their helpful and valued contributions have informed the set of proposals discussed below and detailed at Annex G. We are not proposing any changes to the Part C legislative provisions in the Building Regulations. Proposals to change the guidance in Approved Document C will be made by amendment slip rather than by republishing Approved Document C and the amendments proposed are set out at Annex G.

### Radon

101. The Requirement C1 of Part C in Schedule 1 to the Building Regulations currently requires reasonable precautions to be taken to protect the health and safety of building occupants from contaminants. This includes the risks associated with radon, a naturally occurring radioactive gas that has been identified as the second largest cause of lung cancer in the UK after smoking. Approved Document C provides guidance on where protective measures should be installed in new buildings and extensions in radon affected areas.
102. This is one of a number of Government interventions to address health risks associated with radon. These include a Department of Health programme with the Health Protection Agency to address risks in existing homes by raising awareness, encouraging homeowners to survey the radon levels in their properties, and encouraging those with elevated radon levels to have work carried out to reduce the radon levels. In addition, radon in workplaces is addressed under the Health

and Safety at Work etc. Act. This is supported by the Health and Safety Executive guidance<sup>5</sup>, including an Approved Code of Practice for employers with premises in higher-risk radon areas.

103. The guidance in Approved Document C refers to guidance published by the Building Research Establishment, and radon maps published by the Health Protection Agency and British Geological Survey in 1999. These publications were revised in 2007 to reflect improved knowledge on the prevalence of radon across the UK. We have examined the costs and benefits of aligning the Approved Document guidance with the 2007 radon maps, and this analysis is shown in the Impact Assessment that accompanies this consultation and which is available at:

[www.communities.gov.uk/publications/planningandbuilding/brconsultationsection1](http://www.communities.gov.uk/publications/planningandbuilding/brconsultationsection1)

104. In addition, we have examined the costs and benefits associated with the Health Protection Agency recommendation that Building Regulations should be extended to require all new buildings, extensions, conversions and refurbished buildings in the UK to include (at least) basic radon protective measures.
105. The Health Protection Agency also recommended that the regulations should require radon tests to be carried out in new homes. Government and the Agency continue to explore alternatives to encourage home owners to seek radon testing, which might bring increased consumer awareness and incentivise owners to introduce additional protection where appropriate. We believe it would be premature to develop proposals in respect of this recommendation whilst these investigations continue and none are included in this consultation.
106. Our Impact Assessment shows that there is a strong net economic/health benefit from updating to align Approved Document C with the 2007 radon maps. However, we were not able to produce an economic case to support extending the Building Regulations to require radon protection measures to all new buildings, rather than only those identified from the maps as being in areas of higher radon risk. The evidence base on radon epidemiology continues to be developed and we will continue to work further with the Health Protection Agency and other specialists over coming years to understand the significance of this.
107. Therefore, we propose, subject to consultation, updating Approved Document C in 2013 to align it with the 2007 radon maps.

<sup>5</sup> <http://www.hse.gov.uk/radiation/ionising/radon.htm>

108. We have used a number of working assumptions in this analysis which we will refine during this consultation process and we would welcome evidence and data to assist us with this. These which are outlined in paragraph 86 of the Impact Assessment include estimates of the costs of installing radon protective measures (Impact Assessment paragraph 36 and 37); the assumption that there will be no transitional costs for aligning the regulatory intervention with the BR211 maps although there would be for aligning with the Health Protection Agency recommended extension (Impact Assessment paragraphs 47 and 69 to 73) and the assumptions on how radon protective measures reduce radon levels in homes by 50% and extensions by 25% (Impact Assessment paragraphs 52, 50 and 60).

#### **Question 4.1**

Do you have any evidence that would be helpful when we refine our analysis, including the working assumptions in the Impact Assessment, post consultation?

## Site investigation

109. Following a review with key industry partners we propose no substantial changes to Section 1 of Approved Document C other than to update some references to align these with the introduction of the Eurocodes-based British Standards that were discussed in Chapter 2. These are shown at Annex G.

## Guidance related to contaminated land

110. Our recent review has also considered whether the guidance on contaminated land in Approved Document C is providing what is needed. This work continues and we will be examining in the future whether changes might be appropriate in the light of changes to related legislation such as the proposed simplification of the contaminated land regime under Part 2A of the Environmental Protection Act 1990 which Government recently consulted on. Revised Part 2A statutory guidance is expected to come into force early this year, and it is expected that this will be followed by new technical guidance later in the year to help clarify when land is, and is not, "contaminated land" as defined. As we prepare for this we would welcome views on the current Approved Document C guidance.
111. However, we do propose to remove the current Annex A of Approved Document C in 2013 as this provides little assistance and may actually add confusion rather than clarification.



### Question 4.2

Would removing Annex A of Approved Document C cause problems?

### Question 4.3

Do you have any other suggestions for change that you believe we should consider in our future review work?

## Flooding

112. As part of the December 2010 announcement on areas that would be subject to further consideration, the Department said it would look at whether there was a case for incorporating consideration of flooding within the Building Regulations. This was in response to continuing calls for regulation in this area and the recommendation in the Pitt Report on Flooding<sup>6</sup> that said Building Regulations should be revised to ensure that all new or refurbished buildings in areas of high flood-risk are flood resistant or resilient. It also recognised that some evidence indicated that there was a cost-benefit case to support a targeted approach in certain high flood-risk areas.
113. The work was carried out within the context of the Government's commitment to preventing unnecessary building in areas of high flood risk and an approach that views regulation as a last resort to address problems that cannot be addressed effectively in other ways. Consideration covered both incorporating flood resilience and resistance in new buildings and in the repair of existing buildings in areas of high flood-risk. Usefully, it looked at this as part of a much wider piece of work that considered a wide-range of possible interventions to address the issue.
114. This further work has principally been undertaken as part of the Department's involvement with the Department for Environment, Food and Rural Affairs-led work considering flood-risk management and flood insurance. In particular, the issue was considered as part of one of the working groups made up of key external partners looking at how resistance and resilience measures could reduce risk and how the take-up of resilient repair could be better promoted and communicated.
115. In relation to incorporating resilience and resistance into new development, it was agreed that it was sometimes necessary and appropriate to address any residual level of flood risk through property-level measures. However, despite the absence of any legislative requirement, the group was of the opinion that there was no evidence which suggested that there was currently a significant problem with new

<sup>6</sup> *Learning lessons from the 2007 floods* (June 2008) is available at: <http://webarchive.nationalarchives.gov.uk/2008096001/cabinetoffice.gov.uk/thepittreview.aspx>

development not properly addressing the potential risks from flooding where it was appropriate to do so. Appropriate consideration appears to be being delivered through decisions taken at the local level through the planning system.

116. With regard to repair of properties, it was generally accepted that for some buildings in areas of high flood-risk it would be cost-effective for repairs to incorporate flood resilience/resistance and thereby reduce the impact of a future flood. However, it was also recognised that such repairs can cost significantly more than standard repairs and would only pay back in the event of further flooding. Further, and for a variety of reasons, some individuals have been resistant to undertake such repairs even where they have the information at their disposal explaining what can be done and how it might benefit them.
117. The group felt that there remained opportunities to better promote the voluntary take-up of such measures and, therefore, agreed that the immediate focus should be on raising awareness and information sharing. On that basis, the Department does not believe that regulation which would require people to repair their property in a certain way is currently desirable. Government will, however, monitor how the take-up of resilient repair changes in the future as information needs are better met and market innovation in this area increases.
118. However, to help support appropriate voluntary provision, the Department is keen to ensure that the guidance in the Approved Document properly signposts relevant additional information. To that end, we propose to update the references in Approved Document C to further sources of information as shown at Annex G – principally to refer to guidance in *Improving the flood performance of new buildings – Flood resilient construction* produced jointly by the Department, Defra and the Environment Agency in 2007.

## Minimum U-value of floors, external walls and roofs

119. We are currently examining whether changes should be made to the Approved Document C guidance on thermal transmittance (U-value) to prevent surface condensation and mould growth in floors (paragraph 4.22), walls (paragraph 5.36) and roofs (paragraph 6.14) to reflect insulation changes in Part L. However, no changes are currently proposed.

# Chapter 5

## **Amendments to Parts K, M and N (Protection from falling, collision and impact, Access and Glazing), and new style for Approved Documents**

### Background

120. The Ministerial announcement in December 2010 set out our intention to look at rationalisation of the Approved Documents that support Parts K, M and N to address areas of potential conflict and overlap. In doing so we have sought to provide clarification so as to reduce the cost to industry associated with complying with these provisions.
121. Part K (Protection from falling, collision and impact) primarily deals with the design of staircases, handrails, guarding to areas where falls are possible, projecting surfaces such as windows and collision risks from doors. The Health and Safety Executive estimates that slips, trips and falls in the workplace cost society £800m per year and result in 40 fatalities per year<sup>7</sup>. Approved Document K sets out reasonable and cost-effective measures to limit the likelihood of this type of injury where building work is undertaken. The Approved Document was last updated in 1998.
122. Part M (Access to and use of buildings) primarily deals with ensuring that the built environment is accessible to all users in both employment and in accessing services. Approved Document M sets out reasonable provision for access in most common circumstances and establishes a baseline of cost-effective measures. The supporting Approved Document includes guidance on the design of staircases, handrails, guarding, manifestation of glazing (markings to prevent people walking into glass panels) and collision risks from doors, which overlaps with the guidance that supports Part K and Part N.
123. Part N (Glazing) deals primarily with safe breakage of glazing in critical locations, manifestation of glazing to prevent collision, safe cleaning of windows in commercial buildings, prevention of falling from windows and glazed openings. Much of the Part N guidance is duplicated within Part K or M, although often with different limits in terms of its cited application. However, Approved Document M then states that

<sup>7</sup> Health and Safety Executive Press Release 123:2010 ([www.hse.gov.uk/press/2010/hse-1232010.htm](http://www.hse.gov.uk/press/2010/hse-1232010.htm))

its guidance should be given precedence over Part N where duplication occurs, for instance guidance on manifestation.

124. Changes to Approved Document M in 2004 created a degree of duplication with aspects of Approved Documents K and N. Whilst it might be expected that industry would have adapted to the contradictions between the various different parts of guidance, discussions with designers, building control bodies and contractors support the view that problems persist and that unnecessary costs are being incurred as a result.

## Proposed changes

125. Our proposals seek, therefore, to revise and streamline existing guidance in order to minimise these costs whilst maintaining the critical aspects which deliver a safe and accessible built environment.
126. To achieve this we propose that the guidance supporting Parts K and N, along with some overlapping guidance that currently resides in Approved Document M, will be incorporated into a new consolidated Approved Document K (to be re-titled "Protection from falling, collision and impact and glazing safety"). As a result it is proposed that Approved Document N will be withdrawn. Changes to Approved Document M will be made through the issue of an amendment slip rather than the issue of a new Approved Document (the proposed changes are set out at Annex H alongside the changes proposed on Access Statements which are discussed in the next chapter).
127. Technical changes have been kept to the minimum and are limited to those necessary to resolve conflicts with the existing guidance or with current construction practice. The draft version of Approved Document K (Protection from falling, collision & impact and glazing safety) and accompanying Impact Assessment is provided alongside this consultation document at:

[www.communities.gov.uk/publications/planningandbuilding/brconsultationsection1](http://www.communities.gov.uk/publications/planningandbuilding/brconsultationsection1)

128. Copies of existing Approved Document K, N and M are available to enable comparison of the new and existing guidance from:

[www.planningportal.gov.uk/buildingregulations/approveddocuments](http://www.planningportal.gov.uk/buildingregulations/approveddocuments)

129. It is not intended that the process of consolidation will change existing technical provision, but we are aware that in the process of resolving duplication, minor changes have been necessary. We want to know, therefore, if the revised Approved Document K will create any change in practice.

**Question 5.1**

Are there any changes to the technical provisions in the proposed draft Approved Document K which would impact on the way in which industry applies the existing guidance? If so, can you identify specifically what has changed and what that impact would be.

130. We are also interested in learning whether there are any other additional changes that need to be made to address areas of cost to business as a result of conflicting or confusing advice.

**Question 5.2**

Do you have any further suggestions for areas of consolidation/rationalisation between guidance relating to Parts K, M and N?

## A “new look” Approved Document K

131. The Department has, in conjunction with external partners, been developing a new style for Approved Documents with the intention of making them easier to use. The draft Approved Document K has been produced in the proposed new style and we would be grateful for the views of consultees on the proposed style and format.

**Question 5.3**

Do you think that style and layout of the Approved Document makes it easier to read and use?

132. We have also sought to re-write the revised Approved Document K in a more simple, “plain English” style. This is not intended to change the essence of the guidance or industry practice, but we would welcome views if this potentially creates any difficulty for industry.

#### **Question 5.4**

Are there any changes in the words used in the proposed draft Approved Document K which will impact on the way industry would apply the guidance? If so, can you identify specifically what has changed and what that impact would be.

## Impact Assessment

133. In Table 1 of the Impact Assessment that accompanies these proposals we have set out the transitional costs of implementing and using the revised guidance in Approved Document K. This includes estimates of the number of people likely to be affected, the cost per hour of their time and the likely time required to become familiar with the revised guidance.

#### **Question 5.5**

Do you agree with the estimated transitional costs? If not, please identify which assumptions you disagree with and provide evidence to support alternative values.

134. We have also set out our views as to the likely benefits that will be realised by undertaking this technical guidance consolidation exercise. The potential value of the savings are set out in Table 2 (Central value i.e. our best estimate of savings), Table 3 (High value) and Table 4 (Low value) of the Impact Assessment.

#### **Question 5.6**

Do you agree with the estimated benefits for the rationalisation/consolidation? If not, please identify which assumptions you disagree with and provide evidence to support alternative values.

#### **Question 5.7**

Are you able to provide information to inform further consideration of any of the topics raised in or related to this consultation chapter?

# Chapter 6

## **Amendments to guidance on Access Statements in Part M (Access to and use of buildings)**

### Background

135. The December 2010 announcement set out our intention to review existing guidance that promotes the use of Access Statements in order to consider whether they remain necessary while maintaining the standards of accessibility we are seeking to achieve.
136. This was prompted by a range of concerns expressed during the consultation on future changes to Building Regulations in 2010, and subsequent discussions with key external partners. Whilst there was general agreement that the scope of guidance in Approved Document M is broadly right, there was also agreement that quality of compliance could be improved.
137. Access Statements are a well understood document used both at the stage that a planning application is submitted (as part of the Design and Access Statement in developments where this is a mandatory requirement) and as a recommendation in accompanying building control applications. Access Statements were intended to improve communications between applicants and statutory bodies, and to help ensure that adequate consideration of access issues formed part of the design process.
138. In order to understand better the linkages between Access Statements, the guidance in Approved Document M and effective compliance, we arranged a series of ten workshops involving a wide range of external partners. We discussed our findings (set out below) at a final large scale workshop on 27 July 2011 in order to check that they reflected wider industry viewpoints, and to ask for people's views as to next steps. This consultation sets out the results of this engagement and our proposed actions.
139. In order to further ensure that the anecdotal evidence collected during this process is robust, we have commissioned independent research to determine the frequency and nature of Access Statements submitted at building control stage, an estimate of the likely cost of producing such documents and an assessment of how Access

Statements are typically used in communication with building control bodies. The findings from this research will report during the consultation period.

## Results of initial industry engagement

140. The functional nature of the Building Regulations means that following the guidance in Approved Document M is not the only means by which to demonstrate compliance. Alternative solutions can be proposed providing that they satisfy the building control body that the level of provision is 'reasonable' and satisfies the requirements of Part M. The recommendation to supply an Access Statement was intended to support applicants in setting out why the proposed level of provision was reasonable.
141. The views of external partners vary as to how effective this recommendation has been in practice. Access officers, who work across the planning and building control regimes, stated that they found Access Statements useful in understanding the approach to access adopted by applicants, but noted that even where an Access Statement is mandatory (at the planning stage) the quality and usefulness of Access Statements varied considerably. Access officers also noted that there was confusion as to how planning and building control stages overlapped or were intended to work together.
142. Groups representing disabled people found that Access Statements helped them to understand and comment on proposals prior to implementation, and believed they should be more widely used in particular to address common errors in provision. They also expressed concern as to the level of priority given to access issues by building control bodies and designers and suggested that inclusive design training needed to be improved.
143. Building control officers supported the view that the quality of Access Statements varied considerably and noted that they were typically poor, other than on larger and complex schemes with well-resourced design teams where they were a valuable tool in agreeing reasonable provision. Where Access Statements were not provided or were of poor quality this was not viewed as a particular problem, as building control officers tended to use other information submitted (typically drawings and specifications) to check compliance, and only referred to Access Statements as a secondary resource. This was primarily because written statements could not be relied upon to describe provision accurately and often misrepresented what was included in proposals. Building control officers also suggested that in some instances where access issues were not appropriately considered at the planning stage this could affect good levels of compliance with Approved Document M at the building control stage.



144. Designers noted that Access Statements were most useful in communicating with planning and building control bodies in larger and more complex works, but were not well-suited to supporting improved consideration of access issues during the design process. In part this was because designers found written statements to be divorced from usual working practice and by their nature both difficult and time consuming to integrate into the design process. They were also frequently produced by third-parties outside the design team. Designers suggested that alternative approaches to communicating compliance could be more effective, such as the use of annotated drawings, or meetings which adopted a ‘walkthrough’ approach to explaining access provision. Designers also suggested that inclusive design would be better supported by improving the clarity of the guidance in Approved Document M to make it easier to understand what and when particular provision is required and how this is best achieved.

## Conclusions and proposals

145. In some circumstances Access Statements remain a useful way to communicate how access issues have been approached within proposals, in particular in larger or more complex projects, or to help people less familiar with interpreting drawings to understand proposals. In this respect Access Statements remain a useful tool.

146. However, it is also clear that Access Statements are not always as useful to designers and building control officers, and that the current one-size-fits-all approach is poorly aligned with design and assessment practice and not the most effective way to improve the quality of access. As a result, Access Statements accompanying some building control applications add administrative cost, but little value.

147. There was, however, a broader consensus as to the principle issues affecting quality of access outcomes. These were:

- That where access issues were not adequately considered at the planning permission stage this affected the ability of building control bodies to ensure compliance with the Building Regulations
- The need to raise the profile of inclusive design amongst designers and to consider how skills and understanding amongst professionals can be improved
- The need to consider a revised approach to demonstrating compliance with Approved Document M which more positively engages designers and focuses on quality of outcome
- The need to clarify the relationship between Approved Document M and the Equality Act to ensure that designers and clients are making well informed decisions as to the level of provision when undertaking building work

- The need to review and improve existing guidance in Approved Document M so that it is easier to apply and better supports designers and clients in ensuring that reasonable provision is made in accessing and using facilities within buildings.

148. We propose a number of actions to address these findings and these are set out below.

## A revised approach to demonstrating compliance

149. We believe that the current guidance should be revised to move away from reliance on written documents and instead set out the need to agree an access strategy for proposed building work which ensures reasonable provision by focusing on key risks and issues. The revised approach is also intended to encourage a wider range of interaction between applicants and building control bodies which may be better suited to the skills and resources available to applicants. The proposed revised wording is set out at Annex H (alongside the amendments that result from the consolidation of guidance in Approved Documents K, M and N dealt with in the previous chapter).

### Question 6.1

Do you agree that the proposed alternative approaches to written Access Statements can be effective in helping to communicate compliance?

## Clarifying the relationship between Approved Document M and the Equality Act 2010

150. Almost all of the people we talked to expressed the view that the duties now required by the Equality Act 2010, and the way in which these relate to Part M of the Building Regulations, are poorly understood. In order to provide clarity we have already issued a Circular letter to building control bodies, and we are also proposing to amend guidance setting out this relationship in Approved Document M. The proposed text is at Annex H.

### Question 6.2

Does this revised wording clarify the relationship between Approved Document M and the Equality Act 2010? If not please suggest how this could be made clearer.

## Access Statements at planning and building control stage applications.

151. We recognise that there continues to be confusion as to which matters are best considered at the planning stage and those matters which are best considered at building control stage.
152. Developers should already be aware that local authorities have a duty to consider access and equality issues both in setting out their local plan policies and also in making decisions on planning applications. Since 2004, most types of planning application are required to include a Design and Access Statement to ensure that access is considered right at the outset of the preparation and design of developments.
153. To address this, as part of our work with professional bodies, the Department will consider how a clearer understanding of access considerations at a planning and building control stage can be promoted.

## Improving skills and understanding amongst design professionals

154. Professionals, including building control officers, planners, access officers, architects, landscape architects, engineers, surveyors and interior designers all have an important role in improving the quality of access in the built environment. Inclusive design now forms part of most continuing professional development programmes and educational curriculae. Extensive guidance has also been produced by a range of bodies including the British Standards Institute and the Campaign for the Built Environment.
155. To encourage further improvements to training and to raise the profile of inclusive design amongst built environment professionals, we will hold a roundtable of professional bodies to explore how they can work together to further support professionals in designing accessible environments.

## Improving guidance in Approved Document M

156. Approved Document M was last fully reviewed in the period 2000-2004. We do not propose to undertake a full review of the guidance as part of this programme of work leading to changes in 2013.

157. We do, however, recognise the widely held view that the existing guidance in Approved Document M can be improved in order to address common errors in application which reduce amenity for disabled people when using buildings and their facilities, and that there is room for improvement in making it easier for designers and builders to meet the provision of Part M in practice.
158. We will therefore start a process of scoping research to understand the potential benefits of broader review of guidance supporting Part M of the Building Regulations.

## Impact Assessment

159. An Impact Assessment setting out the overall costs and benefits of this proposals is available at:
- [www.communities.gov.uk/publications/planningandbuilding/brconsultationsection1](http://www.communities.gov.uk/publications/planningandbuilding/brconsultationsection1)
160. As part of this consultation we are seeking views as to the accuracy of the assumptions underpinning the accompanying Impact Assessment.

### Question 6.3

Table 3 on page 9 of the Impact Assessment sets out the percentage of building control applications currently accompanied by an Access Statement, banded by project size. Does this seem reasonable or do you have evidence to substantiate alternative figures?

### Question 6.4

Table 5 on page 10 of the Impact Assessment sets out as transitional costs the time and cost to industry in becoming familiar with revised guidance within Approved Document M and developing revised approaches to communicating compliance. Does this seem reasonable or do you have evidence to substantiate alternative figures?

### Question 6.5

Table 6, 7 and 8 on pages 12 and 13 of the Impact Assessment sets out the extent to which revised guidance will deliver efficiencies to industry and seeks to evaluate the benefits this will bring. Do you agree with our estimate of time, and cost which will be saved by a more focused risk-based approach to demonstrating compliance? If not, please suggest what values should be considered and provide any supporting evidence.

**Question 6.6**

Table 7 on page 12 of the Impact Assessment sets out the underlying assumptions in the calculations of savings to homebuilders – do you agree with these figures? If not, please suggest what values should be considered and provide any supporting evidence.

**Question 6.7**

Are there any costs to industry not identified within the consultation stage Impact Assessment that we should include? If so, what are they and what can be provided to substantiate such costs?

**Question 6.8**

Are you able to provide information to inform further consideration of any of the topics raised in or related to this consultation chapter?

# Chapter 7

## Domestic security

### Background

161. There are currently no requirements within the Building Regulations for domestic security, although the Building Act (as amended by the Sustainable and Secure Buildings Act 2004) gives the Secretary of State powers to make regulations for this purpose.
162. This consultation sets out the background to the Department's evaluation of whether there is a case for regulatory intervention to require minimum security standards for new domestic properties and for replacement doors and windows in existing homes.
163. A number of responses to our July 2010 "call for ideas" suggested that the Building Regulations should be extended to include provisions to ensure adequate security measures are incorporated into domestic buildings. There was no consensus, however, as to what provisions would be appropriate. In his Written Ministerial Statement in December 2010, Andrew Stunell then set out the Department would:
- "Explore further the case in relation to minimum standards for security in homes and consider whether national regulation might be a more effective approach than voluntary and local interventions."
164. This work has been taken forward in collaboration with the Home Office. We have also engaged in a series of workshops with key industry partners to consider what role the Building Regulations might play in reducing the risk of burglary through the introduction of target hardening<sup>8</sup> security measures.
165. To better understand this issue the Department has commissioned the Building Research Establishment (BRE) to undertake independent research to evaluate the costs and benefits of varying levels of security and assess their likely effectiveness in reducing the risk of burglary in domestic properties.

<sup>8</sup> The strengthening of the security of a building through the use of locks to doors and windows in order to reduce or minimise the risk of attack or theft.

## Analysis and consultation

166. We have already undertaken extensive consultation with industry through a series of workshops, bilateral discussions and questionnaires in order to obtain information on the various security standards available, their likely effectiveness in reducing the risk of burglary and their cost of installation. This information has helped BRE develop the assumptions for this analysis.
167. Evidence gathered to date clearly supports the assertion that improved levels of effective security helps to reduce the likelihood of unauthorised access. However, whether this is cost-effective on a national basis is reliant on the cost of the security measures applied, by how much they are likely to reduce forced entry and the prevalent rate of burglary. We would welcome any further evidence on these factors in order to ensure that our current assumptions are robust.
168. Discussions with industry indicate that security standards in new homes and in replacement doors and windows have improved considerably over the last ten years. At the same time the rate of burglary has dropped by 63% since its peak in 1995. This means that the balance of risk has considerably reduced, and initial analysis suggest that this has had the effect of marginalising the benefits of adopting higher levels of security on a national level.
169. Table 1 below sets out the different levels of security considered. Separate analysis has been undertaken for main doors, other doors (such as side or rear doors) and for windows to reflect the varying levels of risk associated with forced entry for each.

**Table 1: Description of levels of security**

Level of security	Description	Relevant application
Level 4	<p>A good quality door with a single standard cylinder type lock or two locks not both set apart as required for level 5 within the same vertical third of the door.</p> <p>Windows generally double glazed without key locks.</p>	DIY market and heritage buildings.
Level 5	<p>Good quality door that is double glazed or contains no glazing and a strong frame.</p> <p>Either an auto deadlocking rim lock in the top one-third of the door plus a mortise lock in the lower third of the door or a multipoint locking system with hook bolts.</p> <p>Double glazed windows with key locks (to the relevant British Standard for basic security).</p>	Typical private housing, replacement door and windows application.
Level 6	<p>A security door system (including door, frame and lock) certified to the relevant British Standard.</p> <p>Double glazed windows with key locks (to the relevant British Standard for enhanced security).</p>	Enhanced security.
Level 7	<p>Excellent quality door (no apertures) assessed to third-party security standard for enhanced security.</p> <p>Windows of extremely robust construction (lock standards above level 6). Assessed to third-party security standard for enhanced security.</p>	Currently very limited application (possible adoption for embassy buildings or other high security buildings).



## Conclusions

170. Initial findings suggest that existing industry standards (which sit just below level 5) are generally cost-effective.
171. At the current rate of burglary it would appear there are benefits in adopting level 5 security for main doors only (around £400k benefit per annum). However, if applied to other doors and windows, the level 5 standards would appear not cost-effective and cumulatively could create a net cost of approximately £2- 3m per annum. Higher standards would not appear to show any net benefit at a national level given the current conditions.
172. It is still too early to be clear whether the latest figures from the British Crime Survey suggest any real change in the medium-term trend for burglary which has been relatively stable since 2004/05. That said, there are some areas in England which already experience burglary rates higher than the national average and the modelling suggests a targeted locally applied approach could prove cost beneficial and support real reductions in the risk of burglary in those areas. In order to be sure that such an approach is viable we would need to establish more finely grained evidence on cost and performance of security products and localised variations in burglary.
173. Speaking with key external partners it has been suggested that consumers purchasing new homes or deciding on replacement doors and windows might also benefit from being better informed as to the relative security performance of the products they are buying, much as they are now able to do in considering the energy performance of appliances or varying levels of car security. Currently information is poor at the point of purchase, but if a targeted approach proves to be viable, this would imply that improved consumer advice could be developed on the same basis.

## Next steps

174. The initial analysis appears to indicate that targeted application of higher levels of security could be effective. Further work is required to refine evidence and to establish if such a risk-based approach is practical and viable. We will work with industry in order to determine how applying higher security standards on a localised basis could work outside of regulation.

175. Overall the initial results suggest that there is no case to take forward the development of regulatory proposals for a minimum security standard on a national basis at this time. However, if circumstances change over time the balance could shift in favour of adopting minimum standards. We therefore propose to keep this policy under review, and will report on any significant developments to Ministers in 2013.
176. That said, we believe that consumers should have greater opportunity to decide themselves whether they wish to invest in enhanced levels of security when buying new homes or replacement doors and windows. To address this we propose to facilitate work with industry and the Home Office to develop a consumer friendly, industry-led security rating system for domestic security products to support more informed choice at point of purchase.

**Question 7.1**

Are you able to provide information to inform further consideration of any of the topics raised in or related to this consultation chapter?

# Chapter 8

## Changing Places toilets

### Background

177. We set out in December 2010 our intention to consider whether there was a case for Government intervention to deliver better provision of Changing Places toilets. These toilets provide extra facilities for people with profound and multiple learning disabilities, as well as other serious impairments such as spinal injuries, muscular dystrophy, multiple sclerosis or an acquired brain injury. They are different from standard disabled toilets with more space and extra features such as adjustable changing tables and hoists.
178. The number of disabled people who require such facilities is steadily increasing; primarily due to improved health care ensuring profoundly disabled children live into adulthood and old age where previously they would have been unlikely to do so. It has been estimated that up to 230,000 people would benefit in the UK from improved provision.
179. There are currently no requirements to provide such facilities. Current provision is largely dependent, therefore, on developers providing them voluntarily and/or local authorities either providing them directly or requiring others to do so, for example, through the planning system.
180. The level of provision achieved so far has been largely influenced by the work and campaigning undertaken by the Changing Places consortium and individuals and local groups across the country. That effort has delivered significant advances over a relatively short period of time and as of November 2011 there were 257 Changing Places toilets in England.
181. However, provision of these facilities does vary significantly between areas and there have been calls, given the clear need to ensure provision continues to improve into the future, for Government to incorporate a requirement in the Building Regulations for them to be provided in certain buildings.
182. In the light of the above, the Department committed to considering the issue further as part of the wider work looking at possible changes to the Building Regulations.

## Considering the options

183. The Government believes that regulation should only ever be used as a last resort and alternative, non-regulatory approaches, are favoured where they are equally or more effective in addressing a particular issue.
184. This means, therefore, that before a regulatory option could be brought forward to improve the provision of Changing Places toilets, it would be necessary to establish and demonstrate that non-regulatory approaches would not work. Fundamental to doing this is a thorough understanding of the nature and scale of the problem.
185. As a starting point we have worked closely with Mencap and the Changing Places campaign to assess what evidence is available and to clarify the current barriers to increased provision of Changing Places toilets. This work suggests that where local authorities and business are aware of the need for Changing Places at a corporate and policy level, other difficulties – including cost, maintenance, insurance and location – can be resolved more easily. There is also broad support to explore a positive, collaborative approach before looking to make business construct facilities which they may then be reluctant to properly manage in use.
186. We believe that there are other benefits in adopting a collaborative approach beyond building owners positively embracing their role in the on-going management of facilities. These include the ability for local partnerships to plan strategically to put facilities where they will achieve greatest benefit; a much broader reach than can be achieved through regulation (the Building Regulations do not apply to ports, airports or railway stations amongst other buildings) and the ability for organisations to work in partnership to maximise their own strengths and abilities.
187. To understand how this might work, the Department sought information and evidence from a number of key external partners to establish the current situation on the ground and to assess the potential appetite and opportunity for a “voluntary” (rather than regulatory) approach to providing better provision. The results of these discussions have been encouraging.
188. Government intends, therefore, to try and facilitate an approach involving external partners working together to deliver better provision in the future. Whilst the Department will play an active role at the outset, in the longer-term our ambition is for our external partners to take this work forward. However, we will also be keen to monitor whether such an approach is actually delivering the better provision hoped for. We hold open, therefore, the option of returning to the issue of regulation at some point in the future if alternative approaches are shown to be ineffective in delivering better provision.

## Approved Document M (Access to and use of Buildings)

189. Current provisions within Part M of the Building Regulations do not require a Changing Places toilet or other similar facility to be provided. However, there is relevant guidance already in Approved Document M which seeks to encourage consideration of the issue. This suggests in paragraph 5.17 under “design considerations” for toilets in buildings other than dwellings that:
- “In large building complexes, such as retail parks and large sports centres, there should be one wheelchair-accessible unisex toilet capable of including an adult changing table”.
190. The guidance contained in Approved Document M was last updated in 2004 and prior to the development of the more detailed technical guidance on the requirements for adult changing facilities which are now known as Changing Places toilets. As such, the current Approved Document fails to provide as much information as would be helpful for those who are looking to provide such a facility voluntarily.
191. Given that lack of understanding and awareness have been identified as significant barriers to increasing provision, we believe that this existing information represents a missed opportunity. Therefore, whilst we are not proposing to make provision of an adult changing facility a requirement, we believe there is merit in updating the Approved Document to include better information about how to ensure facilities are adequate where they are being considered on a voluntary basis.
192. Information as to what items are necessary and as to the size and layout of the room are already contained in BS 8300: 2009 *Design of buildings and their approaches to meet the needs of disabled people*. Although it would be possible to simply reference the relevant part of the British Standard we would welcome the views of consultees as to whether it would be more helpful to provide supplementary information in the Approved Document itself which sets out the substance of what is considered necessary to ensure a facility is adequate, for example, by providing a diagram to show the features and layout of a typical adult changing facility.

### Question 8.1

Should Approved Document M be amended to provide information about what is needed from a Changing Places toilet and, if so, should this be a simple reference to BS8300 or should the information be in the body of the Approved Document?

193. The proposed approach relies on the fact that Approved Documents provide a powerful way to communicate information to a large number of people responsible for the design and construction of buildings (even where, as is proposed here, this information is not backed up by a statutory requirement). However, because of that, the Department is also mindful of the need to ensure there are no adverse impacts that arise as a result of providing supplementary information alongside statutory guidance. Whilst the Department believes that providing information on something that is provided voluntarily does not impose any adverse impacts on potential providers, we would welcome the views of consultees as to whether this is the case.

**Question 8.2**

Would providing additional guidance of the sort proposed lead to any adverse impacts on building providers/occupiers?

# Chapter 9

## Amendments to the Approved Document supporting Regulation 7 (Materials and workmanship)

### Background

194. The EU Construction Products Regulation (Regulation 305/2011) came into force in April 2011 with most of its provisions applying from 1 July 2013. From that date, most construction products will have to be tested against harmonised EU standards and CE marked before they can be placed on the market in the UK.
195. We therefore propose to amend Approved Document 7 to clarify that the declarations of performance and CE marking required under the EU Regulation will become the main source of information on the performance characteristics of construction products from July 2013. We have also taken this opportunity to propose other minor changes to the Approved Document. No changes are proposed to Regulation 7 itself.
196. The EU Regulation enters directly into UK law, without the need for transposing domestic regulations. However, the current UK Construction Products Regulations (SI 1991/1620 & SI 1994/3051) will need to be revoked and replaced by regulations providing for enforcement of the EU Regulation in the UK. We intend to lay these new regulations in April 2013 for implementation in July 2013. An Impact Assessment will accompany these regulations.
197. Our proposed amendments to the Approved Document are at Annex I and are explained below.

### Introductory sections

198. *Use of guidance:* This section is common to all the Approved Documents and the proposed amendments are to:
- Delete reference to Wales, as the power to make Building Regulations in relation to Wales transferred to Welsh Ministers on 31 December 2011

- Refer to amendments to guidance on meeting Regulation 7 contained in other Approved Documents
- Delete references to European Technical Approvals and harmonised European standards, as they are out-of-date and/or discussed more fully in section 1.

199. *The Requirement and Guidance*: The changes we propose in these sections are to:

- Confirm that Regulation 7 applies across all Parts of the Building Regulations
- Clarify the distinction between materials and products
- Delete the text on the environmental impact of building work.

200. We have deleted the paragraph on the environmental impact of building work because developments since the Approved Document was published mean that this issue now goes much wider than Regulation 7. So, for example, domestic water efficiency is now covered in Part G, and Part L changes are made in the context of the move towards zero carbon standards for new buildings. As such, we do not consider that this reference to recycled/recyclable materials adds anything, and propose to remove it.

## Section 1: Materials

201. We propose to re-order and update the text to give due prominence to the consequences of the Construction Products Regulation 2011. We see this as the most significant change that we are making to the Approved Document. The new Regulation was adopted in March 2011 and published in the Official Journal of the EU on 4 April 2011 as Regulation EU 305/2011. Whilst it came into force on 24 April most of the provisions apply from 1 July 2013. It replaces and simplifies the Construction Products Directive 1988 (which will cease to be effective in 2013). The Regulation applies directly in UK law.

202. The Construction Products Directive is an internal market Directive which aims to overcome the technical barriers to trade created where different countries in Europe have different standards, testing and labelling approaches for the same products. The Directive introduced the concept of CE marking for construction products as a “passport” enabling products to be placed legally on the market in any Member State. Most EU Member States have made CE marking mandatory for all products within the scope of the Directive which are placed on their markets. In the UK, this is voluntary. The new Regulation seeks to clarify, simplify and improve the credibility of the CE marking provisions. Further information on the implementation of the Regulation and proposed changes to secondary legislation will be published in 2012.



203. Neither the Directive nor the new Regulation affect the rights of Member States to set performance requirements for products used in building or civil engineering works. But they do prohibit authorities from imposing additional testing requirements for those products, because the CE marking should contain all the information needed to assess whether or not the product meets any regulatory requirements for use. The Building Regulations do not prescribe which products can be used in works, simply (via Regulation 7) that these are fit for their intended purpose. Guidance in the Approved Documents to other Parts of the Regulations may refer to performance values for materials and products as part of suggested design solutions, but these do not prohibit designers from demonstrating that the works meet the regulatory requirements in other ways.
204. Many UK manufacturers already CE mark their products on a voluntary basis under the Directive, whether for export or sale/use in the UK, and harmonised European standards are progressively becoming the norm for testing and declaring performance, as national standards are withdrawn. However, under the new Regulation, from 1 July 2013 manufacturers of construction products covered by harmonised European product standards will be required to make a declaration of performance and to CE mark products in accordance with the relevant harmonised technical specification in order to place the products on the market. As the majority of construction products are covered by harmonised European product standards, these declarations of performance and CE markings will become the main source of information on the performance characteristics of construction products.
205. The Regulation concerns the conditions which apply when placing a product on the market. As such, we do not intend to amend Regulation 7 itself, and CE marking will not be mandatory for the use of products in controlled building works. Other methods of showing fitness for purpose will continue to be allowed, and examples are/will be described in the Approved Document. However, in practice, most products will carry the CE marking, as this will have been affixed when the products were put on the market.
206. We have also taken the opportunity to make minor amendments, updating and clarifying other parts of this section.
207. We have deleted paragraph 1.8 on resistance to moisture and 1.9 on resistance to substances in the sub-soil, on the basis that they are covered, and in more detail, in Approved Document C.

## Section 2: Workmanship

208. We have updated, but not made any substantial changes to, Section 2 on workmanship.

## Appendices

209. *Appendix A*: Lists where other Approved Documents give guidance on the application of Regulation 7 that is to be replaced by amended text.

210. *Appendix B*: We have changed this from a list of abbreviations and glossary to a list of sources of further information.

211. *Appendix C*: We have updated the list of relevant standards in the BS 8000 and 9000 series.

### **Question 9.1**

Do you have any comments on the proposed amendments to Approved Document 7?

# Annex A

## Overview of the regulatory costs and benefits associated with the consultation proposals

1. The Government is committed to reducing the burden that falls on business as a result of regulation. It believes regulation should be a last resort and used only where it can be established that alternative approaches would not provide an effective response to a particular problem.
2. To assist with the drive to reduce the regulatory burden, Government has adopted a “one-in, one-out” approach to regulation. This requires that where a new regulation imposes a net cost on business (an “in”) this is offset by at least an equivalent net reduction or benefit (an “out”). In addition, the Government has a separate, specific commitment to reduce the total regulatory burden on the house building industry during this Spending Review period – April 2011 to March 2015. The Impact Assessments that are produced alongside changes to regulation also inform these two commitments.
3. This consultation package is accompanied by nine Impact Assessments which set out the evidence on issues that our proposals seek to address and explain the rationale for a regulatory response. These assessments provide information on the costs and benefits associated with the proposals and establish where they will fall.
4. These figures may change in the light of the consultation (with the exception of the Local Acts assessment which is a final one), both as proposals are refined and/or as we develop an even better understanding of the costs and benefits. Such changes would be reflected in the Impact Assessments that accompany the implementation of proposals. However, they currently provide our best estimate of how the proposals will impact on business and the table below illustrates the overall regulatory picture for the package as a whole.
5. As can be seen, in terms of the overall impact on business, the package of proposals includes a significant deregulatory element which delivers a net benefit to business (or “out”) of £63.1m per year.

<b>Regulatory Overview of the Proposed Changes</b>		
	<b>Overall Regulatory Out (£m per year)</b>	<b>Overall Regulatory In (£m per year)</b>
<b>Part P (Electrical Safety)</b>	9.7	–
<b>Rationalise Parts M, K &amp; N</b>	8.4	–
<b>Access Statements</b>	17.5	–
<b>Part L (Conservation of fuel and power)</b>	–	Zero (see separate table below)
<b>Part B (Fire safety)</b>	25.4	–
<b>Radon</b>	–	0.5
<b>Eurocodes<sup>9</sup></b>	–	0 (8)
<b>Building Control System</b>	1.8	–
<b>Local Acts</b>	<b>0.8</b>	–
<b>TOTAL</b>	<b>63.6</b>	<b>0.5</b>

6. However, these “outs” do not fall uniformly across business. In particular, most of the regulatory savings relate to the non-domestic sector rather than the house building industry (only £5m of the £63.6m total savings<sup>10</sup>). Conversely, the proposals contained in Part L to further improve the energy performance of new homes represent a significant “in” for house builders. This is principally because the energy savings which are a consequence of these increased costs accrue to homeowners rather than to developers. This is considered further in the paragraphs below dealing with new homes.
7. Given where these and associated Part L costs fall, the table below provides further information about the costs and benefits of this element of the package. Consultees may wish to note that for assessing one-in, one-out, the preferred overall Part L package, taken as a whole, is viewed as being neutral – neither an “in” nor an “out”. This is because Part L is a regulatory package (a potential “in”) where the overall benefits to business outweigh those costs (by £7m). However, for the purposes of one-in, one-out an “in” cannot be negative. In these circumstances, the net cost is treated as zero.

<sup>9</sup> This £8m annual equivalent cost is a Europe-related change and therefore does not count as an “in” for the purposes of one-in, one-out.

<sup>10</sup> The savings to house builders relate to £3m from proposals about Access Statements, £1m from the rationalisation of Parts M, K and N and £1m because of changes to the building control system.

<b>Part L 2013 Impacts on Business<sup>11</sup></b>			
	<b>Equivalent annual cost to business (£m)</b>	<b>Equivalent annual benefit to business (£m)</b>	<b>Equivalent annual net (cost) or benefit to business (£m)</b>
<b>New Homes</b>	(103)	0	<b>(103)</b>
<b>New non-domestic buildings</b>	(210)	311	<b>101</b>
<b>Improved standards for extensions to existing non-domestic buildings</b>	(6)	11	<b>5</b>
<b>Consequential improvements in existing non-domestic buildings</b>	(1)	5	<b>4</b>
<b>Total</b>	-	-	<b>7</b>
<b>One-in, One-out</b>	-	-	<b>zero</b>

## New Homes

8. As set out above, there is a significant regulatory cost to house builders associated with improving the energy performance of new homes. The transitional provisions which will accompany the Part L changes will impact on the scale and timing of these costs and this has been taken into account in our analysis. The Part L Impact Assessment reflects the fact that some developments will be able to use the “existing” 2010 regulations during the transition to the “new” regime. This means that any regulatory changes that come into force in 2013 will not affect the whole market at once. For the purposes of the consultation stage Impact Assessment we have assumed that transitional provisions will result in 40% of new homes in 2014 being built to the new 2013 standards and 60% in 2015. We will be reviewing these in the light of consultation responses.
9. The assumption, therefore, is that the proportion of new homes built to the new regulations will continue to rise over time until 2017, from which point it is assumed that 100% of new homes would be built to the new 2013 standards.
10. Under the methodology for Impact Assessments, we set out costs and benefits in annual equivalent terms (i.e. the total discounted sum of costs and benefits divided by the number of years assumed for the lifetime for the policy). For the Part L changes, once the policy has fully come into effect, the annual equivalent cost to house builders over the lifetime of the policy is estimated to be £103m. Because

<sup>11</sup> Summary of analysis for preferred Option 4 taken from Part L 2013 Consultation Stage Impact Assessment Tables 1.1 to 1.3. Where benefits to business of a regulation exceed costs this represents a zero ‘in’ for one-in, one-out purposes.

this review covers 2013 changes only, even when calculated over ten years we do not include any of the costs which would result from a further change in 2016 to introduce zero carbon standards.

11. The Government is committed to ensuring that the costs on house builders will be at least offset by equivalent deregulatory changes and work is currently in hand to identify these. The Government will announce the equivalent “outs” to balance the “ins” when it brings forward its response to this consultation. If sufficient “outs” cannot be found the Government will adjust its final package accordingly.

## New non-domestic buildings

12. For one-in, one-out purposes, the costs associated with raising the standards for new non-domestic buildings can be offset (unlike for housebuilders where it is individuals rather than businesses who benefit) by the energy savings which are enjoyed by the building occupiers. This means that (based on the Government’s preferred option) for the non-domestic element of the package there is an annual net benefit of £101m (annual costs of £210 million are more than offset by annual benefits of £311 million). This too is based on assumptions about transitional arrangements and the phasing-in of the new standards.
13. **All of the Impact Assessments that accompany these proposals are available alongside the consultation sections on the Department’s website. We would welcome evidence from consultees which helps us develop these assessments further. Areas where we would particularly appreciate your input are spelt out in the relevant part of the consultation.**

# Annex B

## Equality Impact Assessment Initial Screening of the 2010 Building Regulations

**Name of the current regulations being assessed:**

2010 Building Regulations

**Team responsible for completing the screening:**

Building Regulations and Standards Division completed this with assistance from Departmental equalities specialists.

**Main aim or purpose of the current policy:**

The Building Act 1984 enables Building Regulations to be made for England and Wales with respect to the design and construction of buildings and the services, fittings and equipment provided in or in connection with buildings for a number of purposes. These purposes include securing the health, safety, welfare and convenience of persons in and about buildings, preventing waste, undue consumption, misuse or contamination of water, furthering the protection or enhancement of the environment, and facilitating sustainable development.

The 2010 Building Regulations set out procedural requirements (the Building Control System) and, in Schedule One and the guidance in the associated Approved Documents, baseline technical (health, safety, accessibility and sustainability) standards for buildings.

**Sources of evidence used to identify likely impacts on different groups of people:**

This screening was carried out to ascertain whether there are equalities issues with the 2010 Building Regulations which need to be considered as part of the planned review looking at drivers for changing the regulations in 2013. This was done by interviewing the Division's policy leads, drawing on and challenging their understanding of whether there are equalities issues related to the aims and content of the Regulations and the Approved Documents, considering also research, reviews, consultations and Impact Assessments carried out in the past.

It was considered that the team working with the policy leads had sufficient evidence to establish whether the 2010 Building Regulations have any equality impact that needs to be addressed in the review.

### Having analysed the sources of information the conclusions of the screening are:

#### A. Building Regulations Schedule One

- **Schedule One, Part A (Structure)** and the Approved Document providing guidance on meeting the requirements.  
*The screening identified no evidence of equalities issues as provisions on structural stability are likely to impact on all groups equally.*
- **Part B (Fire safety)** and the Approved Document providing guidance on meeting the fire safety requirements.  
*The final Regulatory Impact Assessment that accompanied changes to Part B and its approved Document in 2006 looked at sectors and groups affected and included a race equality assessment and it was felt the changes would not lead to a disproportionate impact on any particular racial group. People with impaired mobility or with cognitive impairments through age or disability are more susceptible to injury or death as a result of fire, but the guidance supporting Part B incorporates measures intended to mitigate the increased risk for disabled people though the risks remain different.*
- **Part C (Site preparation and resistance to contamination and moisture), Part D (Toxic substances), Part E (Resistance to the passage of sound)**, and the Approved Documents providing guidance on meeting the requirements of the Parts.  
*The screening identified no evidence of equalities issues.*
- **Part F (Ventilation)** and the related Approved Document.  
*The screening identified no evidence of equalities issues. However, there are concerns about summer overheating which are outlined under Part L below.*
- **Part G (Sanitation, hot water safety and water efficiency)** and the Approved Document providing guidance on meeting the requirements.  
*Part G was revised in 2010 and the final Impact Assessment for those changes indicated no evidence of equalities issues. However, the Department is aware of concerns that documents referenced in the Approved Document might lead to issues related to adequacy of toilet provision. The Department plans to conduct further research into this.*
- **Part H (Drainage and waste disposal)** and the related Approved Document.  
*The screening identified no evidence of equalities issues.*



- **Part J (Combustion appliances and fuel storage systems)** and the related Approved Document.  
*The screening identified no evidence of equalities issues. Whilst young and older people may be more susceptible to the risks of carbon monoxide poisoning, which Part J addresses, the guidance supporting Part J incorporates measures intended to mitigate the risks although the risks remain different.*
  - **Part K (Protection from falling collision and impact)** and the related Approved Document.  
*The screening identified no evidence of equalities issues. It identified that there are concerns about risks to younger and less mobile people from powered gates, but these are not considered to need Building Regulation intervention as the Health and Safety Executive is examining controls under existing alternative regimes.*
  - **Part L (Conservation of fuel and power)** and the related Approved Documents.  
*The screening identified no evidence of equalities issues. However, there are concerns about how summer overheating which could particularly affect older and disabled people – the Department intends commissioning research to ascertain whether this requires intervention.*
  - **Part M (Access to and use of buildings), Part N (Glazing – safety in relation to impact, opening and cleaning) and Part P (Electrical safety – dwellings)** and the related Approved Documents.  
*The screening identified no evidence of equalities issues other than items already slated for consideration in 2011 for the 2013 review.*
- B. Regulation 7 (materials and workmanship)** and the related Approved Document.  
*The screening identified no evidence of equalities issues.*
- C. Building Control System** (various Regulations) – including compliance checks by the local authority or by Approved Inspectors in the private sector.  
*The screening identified no evidence of equalities issues as the scheme applies equally to all.*
- D. Competent Persons Schemes** (statutory mechanisms which allow registered members of schemes which have been assessed as competent to self-certify that their work complies with the Building Regulations).  
*The screening identified no evidence of equalities issues.*

### **Is a full Equality Impact Assessment Required? No**

This initial screening looked at whether the existing regime has differential impacts on different groups in society including men, women, people from ethnic minorities and people with disabilities that should be examined further in the forthcoming review. We consider the current Building Regulations scheme to be reasonable and proportionate and, in summary, the screening has established no equalities impacts that need to be addressed with further equalities impact assessments of the 2010 Building Regulations, their technical standards and Approved Documents.

The screening identified a number of areas where risks are known to apply in different ways to different groups, such as the young and older people, although it is considered that even in these areas the baseline standards in place are appropriate to the range of risks. It did identify a couple of questions about possible equalities issues and although these were not unequivocal the Department is now looking to understand these better.

Further equalities screening (and, if necessary, equalities impact assessments) will be undertaken of options for change being considered within the various projects reviewing aspects of Building regulations.

Name of Person Signing Off the Initial Screening:

Bob Ledsome.

Bob Ledsome  
Deputy Director, Building Regulations and Standards

21 December 2011

# Annex C

## Equality Impact Assessment – Access Statements

**1. Which group(s) of people has been identified as being disadvantaged by your proposals? What are the equality impacts?**

Part M (Access to and use of buildings) has specific relevance to a wide range of building users ranging from older and disabled people to expectant mothers and parents with younger children. It is therefore important to ensure that the revision of guidance within Part M has no adverse effect on groups with protected characteristics as outlined in the Equality Act.

Extensive discussions with external partners indicate that the current one size fits all approach to demonstrating compliance with the requirements of Part M by submitting an Access Statement, which sets out the approach taken to inclusive design, has not proven effective across all types and scale of building work. In particular, Access Statements are less effective in relation to smaller and less complex works where developers, designers and builders do not have the expertise or resources available in larger scale projects. As a result, Access Statements accompanying some applications add administrative cost but do not improve the quality of access in the resultant building work.

The proposed changes seek to encourage applicants and building control bodies to focus on critical aspects of provision and in particular those areas where alternative approaches to those set out in Approved Document M are adopted. Focusing on critical aspects rather than expending resource on describing where compliance has been easily achieved will help to ensure that quality of outcomes is improved. The proposals also suggest that adopting methods of compliance other than a written statement may be both more effective and more appropriate in some cases. This in turn will improve compliance whilst reducing cost.

The proposals do not change guidance as to what constitutes reasonable provision in most common circumstances, and establishing what should be provided on a case by case basis will remain for individual building control bodies to determine. In other words, the level of provision will not decrease as a result of these proposals. We therefore do not foresee this policy having any adverse equality impact on the groups outlined as possessing protected characteristics under the Equality Act 2010.

However, improving compliance could have positive impacts and specific consideration is given below to the impact of the policy on individual groups:

### ***Disabled People***

Ensuring that, where new buildings are constructed or other building work takes place, suitable provision is made for access to and in the new or refurbished building, could have a significant impact on the opportunities available for disabled people, for example, in terms of employment opportunities and the choices available to them. Changing current guidance to improve consideration of access considerations by designers and building control officers in new and refurbished buildings should impact positively on the quality of life for disabled people.

### ***Older People***

There is a strong correlation between increased disability and old age, and as the population ages, the importance of living in an accessible environment will increase. A broad range of the measures within Approved Document M including those relating to mobility, visual and hearing impairment are relevant to older peoples' ability to access and use the built environment. Any improvement in the quality of access will therefore have a beneficial impact on this group as a result.

### ***Women***

Women still shoulder a disproportionately greater amount of caring responsibilities for family members in old age, young children or for disabled people. Improved outcomes in terms of higher levels of accessibility for vulnerable people, resulting from revised guidance in Approved Document M, could materially improve the situation for carers.

### ***People with young children***

Part M includes a number of provisions which benefit families with young children ranging from level thresholds at doorways which facilitate easier access for wheelchair users to baby changing facilities in publicly accessible buildings.

**2. In brief, what changes are you planning to make to your current or proposed new or changed policy, strategy, procedure, project or service to minimise or eliminate the adverse equality impacts?**

The changes to the guidance regarding Access Statements will be formally consulted upon with new guidance coming into force in 2013.

In order to be able to understand further the impact of revising the guidance, DCLG has commissioned research to assess costs and impacts associated with these policy proposals. This research will additionally provide a benchmark against which changes in policy can be measured at a future date and will report during the consultation period.

However, from discussions with industry and disabled people we recognise that revising guidance alone will not by itself necessarily capture all of the opportunity for improvement. We therefore also propose further work to make compliance with Approved Document M easier which will further improve quality of access to buildings where building work takes place. In the short term, we intend to;

1. Issue a circular letter to building control bodies which clarifies the relationship between Part M and the Equalities Act and the terms of the exemption from the Act with regards to requirements within Approved Document M. This circular will be sent out prior to the 2013 changes, and this clarified guidance will then be incorporated into the amended published Approved Document M.
2. Establish a forum for broader engagement with professional bodies to explore how they can raise profile, awareness and skills amongst their members in order to improve quality of access where building work takes place.
3. Beyond changes proposed for inclusion in the 2013 review;

DCLG will commission scoping work to assess what needs to be done to address issues within existing guidance, and to consider what research is needed to support a broader review of Approved Document M with the aim of ensuring that it continues to meet the needs of a broad range of people in the longer term.

**3. Please provide details of whom you will consult on the proposed changes and if you do not plan to consult, please provide the rationale behind that decision. Please note that you are *required* to involve disabled people in decisions that impact on them.**

DCLG held a series of ten workshops between January and July 2011 to informally gather the views of a wide range of external partners, including Access Officers, designers, disabled people and their representative organisations and building control officers.

A final workshop held in July provided feed back to key partners on the outcomes from this process of engagement to test officials' understanding of the variety and range of views expressed and to ensure that the basis for initial policy development was sound. At the same workshop, DCLG asked for the views of a range of key partners as to what might be done in order to address the issues identified.

Findings from this programme of engagement have fed into the proposals to be taken forward for formal public consultation provisionally scheduled for early in 2012. The Building Regulations Advisory Committee (BRAC) has advised Ministers on the consultation proposals. BRAC includes members with a particular interest in access issues.

The consultation exercise will be conducted in line with the Consultation Code of Practice. DCLG will arrange workshops with industry and interested organisations during the consultation period in order to ensure that they have the opportunity to comment on proposals in detail and the policy will then be amended as necessary once the responses have been received and analysed.

**4. Can the adverse impacts you identified during the initial screening be justified without making any adjustments to the existing or new policy, strategy, procedure, project or service? Please set out the basis on which you justify making no adjustments.**

The starting point for this review was an assumption that Access Statements were not proving effective in use and that better outcomes could be achieved through the removal of all guidance relating to Access Statements in Approved Document M.

However, following extensive engagement with key external partners, including disabled people and their representative organisations, it became apparent that Access Statements remain of use in some circumstances, particularly when accompanying applications relating to larger scale and more complex projects.

We incorporated these findings into our final policy proposal, having recognised the value of retaining guidance on Access Statements but encouraging applicants to adopt a more risk-based approach to communicating compliance to both reduce unnecessary administrative burden and achieve better outcomes in terms of accessibility.

The formal consultation and the results of ongoing research will both provide evidence to substantiate the view that there will be no adverse effects as a result of revising current guidance in Approved Document M and we will continue to take equalities issues in to account as policy detail develops.

**5. You are legally required to monitor and review the proposed changes after implementation to check they work as planned and to screen for unexpected equality impacts.  
Please provide details of how you will monitor/evaluate or review your proposals and when the review will take place.**

The Building Regulations have typically been subject to a three year cyclical review, with the proposed changes coming into effect in 2013. It is unlikely that further changes will be made before 2016.

In addition, beyond the scope of the 2013 changes to Part M, DCLG has committed to starting work in scoping research to ensure that Part M and Approved Document M remain proportionate, well-evidenced and will continue to meet the needs of disabled people in the longer term. We will review the impact of these proposed changes as part of that ongoing work.

Name of Person Signing Off the full Equality Impact Assessment:

Bob Ledsome.

Bob Ledsome  
Deputy Director

6 December 2011

## Full Equality Impact Assessment – action plan

Actions taken or proposed	Rationale for the action	Beneficiaries of the action	Timing	Responsibility
<b>Changes made:</b> Changes that have been made to policy as a result of the Equality Impact Assessment.				
Renewed emphasis on longer term fundamental review of Part M to remove and amend as appropriate disproportionate or outdated guidance and ensure provision is targeted and focused on key issues relevant to the project on a case by case basis.	To ensure better outcomes are delivered for the broadest range of users including disabled people and to review the impact of changes to guidance brought in by this policy.	Older people; Groups with a physical disability or reduced mobility; women; mother and pregnant women.	Provisionally leading to further changes in 2016	DCLG
<b>Mitigation:</b> For areas where a policy may have a differential impact on certain groups, what arrangements are in place or proposed to mitigate these effects?				
Formal public consultation will allow affected groups to raise concerns over policy impacts before implementation.	Stakeholder engagement thus far has not raised concern at the suggested approach but formal consultation will provide another route for engagement with key groups.	All affected groups who consider there to be adverse impacts of policy surrounding simplifying guidance on Access Statements and clarifying legal obligations.	January 2012 – April 2012	DCLG
<b>Justification:</b> For areas where a policy may impact negatively (but not illegally) on certain groups but mitigation is not possible (e.g. an overriding societal driver) there needs to be a strategy for handling issues of unfairness.				
NA				



Actions taken or proposed	Rationale for the action	Beneficiaries of the action	Timing	Responsibility
<b>Opportunities:</b> Please state actions designed to maximise positive effects, i.e. opportunities identified for: promoting equality, good relations or knowledge about groups; increasing civic and democratic participation; or addressing inequalities.				
Possible review of guidance within Part M will further advance positive outcomes for a broad range of users, including older and disabled people.	Need to ensure that current guidance is proportionate and effective.	Older people; Groups with a physical disability or reduced mobility; women; mother and pregnant women.	Begin scoping work following implementation of 2013 changes	DCLG
<b>Monitor:</b> How will you monitor the impact and effectiveness of the new policy?				
The periodic review of the Building Regulations will include consideration of Part M and the changes made to guidance resulting from this policy.	To monitor the effectiveness of guidance within Part M at delivering better outcomes.	Older people; Groups with a physical disability or reduced mobility; women; mother and pregnant women.	Post 2013 is likely to be the next review date.	DCLG and external partners.
Work closely with external partners to monitor the impact of policy in practice.	To monitor the impact and effectiveness of the policy on individual cases.	Older people; Groups with a physical disability or reduced mobility; women; mother and pregnant women.	Ongoing.	DCLG/Local Authority Building Control/Approved Inspectors.
<b>Publish:</b> Give details of how the results of the EqIA will be published.				
Full Equality Impact Assessment to be published on the DCLG website	In the interests of transparency.	Members of the public, external partners, local authorities, MPs and other interested parties.	TBC	DCLG

# Annex D

## Equality Impact Assessment – Changing Places

### 1. Which group(s) of people has been identified as being disadvantaged by your proposals? What are the equality impacts?

Changing Places toilet facilities are large highly specialised toilets incorporating an adult changing bench, hoist, peninsular WC shower and other facilities to make suitable provision for the sanitary needs of people who require high levels of support. It is estimated that up to 230,000 people in the UK would benefit from increased numbers and availability of this type of facility.

Currently there are around 300 Changing Places facilities in the UK, and Ministers committed in December 2010 to consider whether there was a case for targeted regulation to support further improvements in numbers of facilities, or for other forms of Government intervention.

Government policy requires that regulation must be considered as a last resort once all other non-regulatory means of intervention are proven to be exhausted. Work undertaken by DCLG has established that more can be done by using government's influence to promote improved awareness and understanding in industry and Local Authorities in order to increase the supply of facilities, without resorting to regulation in the first instance.

We therefore propose to take forward the development of a voluntary approach promoting collaborative working by industry and campaigners to provide more Changing Places facilities.

Our Equality Impact Screening identified that this policy could have positive or negative impacts on certain equality groups, namely:

#### ***Disabled People***

The availability of Changing Places facilities could have a significant impact on the quality of life and day to day choices of disabled people and their carers, for example, by improving their quality of life. Lack of provision of suitable facilities does have a negative impact on this equality group.

### **Older People**

There is a strong correlation between increased disability and old age, and as the population ages, the number of people with very high care needs is likely to increase. Lack of provision of suitable facilities does have a negative impact on this equality group.

### **Women**

Women still shoulder a disproportionately greater amount of caring responsibilities for family members in old age, young children or for disabled people. Improved outcomes in terms of increased provision of changing facilities for vulnerable people, could materially improve the situation for carers. Lack of provision of Changing Places facilities could have a negative impact on this group.

**2. In brief, what changes are you planning to make to your current or proposed new or changed policy, strategy, procedure, project or service to minimise or eliminate the adverse equality impacts?**

This policy seeks to identify the most effective way by which supply of Changing Places toilets can be improved in England. To understand how best this can be achieved, we have been in extensive dialogue representatives of the Changing Places Consortium and MENCAP who lead in England on this issue.

From these discussions, and from evidence we have been able to gather (including directly commissioned research by an independent contractor) we have come to understand that there are significant geographical variations in provision of Changing Places facilities, and a lack of provision in certain types of buildings. However, over 300 facilities have been provided over the last 4 years as the result of local campaigning and collaboration with industry and Local Authorities.

It has become clear that the principle difference between those areas pro-actively developing improved provision and those areas with low or no provision is the extent to which corporate buy in at a high level has been achieved in both industry and local government. Our work therefore focused on understanding what needed to be done to ensure that these barriers are removed so that the success in some areas of the UK can be more broadly replicated.

As a result we have undertaken bi-lateral discussion with key retail and service providers, transport providers, and public bodies which have been identified as having a role in improving future provision of Changing Places facilities. These discussions have revealed general positive support for the development of a voluntary approach and we propose to bring campaign groups and industry representatives together early in 2012 to discuss how a collaborative approach might work.

There are many advantages to such an approach including a wider range of influence than can be achieved by regulating through the Building Regulations (airports, ports, rail

infrastructure and crown buildings are not subject to Building Regulations for instance); that willing engagement is more likely to result in well managed and accessible facilities (Building Regulations do not cover management once building work is complete, cannot guarantee that facilities remain open and/or are maintained properly); and the ability to work strategically to ensure facilities are in the right or best place to benefit users (Building Regulations would only apply where building work is already taking place).

However, we recognise that there is some way to go in establishing how effective a voluntary approach will be. We have therefore committed to review progress in the longer term to identify whether further action by government is necessary.

**3. Please provide details of whom you will consult on the proposed changes and if you do not plan to consult, please provide the rationale behind that decision. Please note that you are *required* to involve disabled people in decisions that impact on them.**

DCLG held a series of meetings between January and July 2011 to informally gather the views of a wide range of external partners, including representatives from the British Retail Consortium, the British Council of Shopping Centres, the British Property Federation, the Planning Officers Society and the Local Government Association as well as the Changing Places Campaign.

The Department has also led regular meetings with Mencap and members of the Changing Places Campaign to understand how these issues affect people in day to day life. We will meet with members of the Changing Places Consortium in January 2012 to consult further on how a voluntary approach could work.

Findings from this engagement have fed into the proposals to be taken forward for formal public consultation provisionally scheduled for early 2012. The Building Regulations Advisory Committee (BRAC) has advised Ministers on the consultation proposals. BRAC includes members with a particular interest in this issue, and have already been consulted on our proposed approach.

**4. Can the adverse impacts you identified during the initial screening be justified without making any adjustments to the existing or new policy, strategy, procedure, project or service? Please set out the basis on which you justify making no adjustments.**

The rationale behind taking action is that more Changing Places facilities are required to meet the needs of a growing number of people with multiple and severe disability that require high levels of assistive care.

In the view of Government a successful voluntary and collaborative approach is preferable to a successful regulatory approach.

Clearly there are risks in adopting a voluntary approach to increasing provision – not least that this may not ultimately deliver the desired outcomes overall. However, we are confident from the work we have undertaken that such an approach can work, and potentially be more effective in practice than a regulatory approach as set out in paragraph 2 above. We believe that this approach is highly likely to ensure a long term increase in provision.

The policy will not have adverse impacts on the affected groups, but it remains to be seen whether regulation may still be necessary in certain circumstances where a voluntary approach may not be successful, to ensure that the benefits of the policy for affected groups are fully realised. To safeguard against this possibility we have committed to keeping progress under review in the short to medium term.

**5. You are legally required to monitor and review the proposed changes after implementation to check they work as planned and to screen for unexpected equality impacts.**

**Please provide details of how you will monitor/evaluate or review your proposals and when the review will take place.**

The Building Regulations are typically subject to a rolling process of review. Some changes are already proposed for 2013, but we do not propose to include requirements for Changing Places at that time. We are commencing scoping work to identify whether further changes to Part M of the Building Regulations will be needed after 2013, and monitoring progress on Changing Places will remain a specific element of this development.

Name of Person Signing Off the full Equality Impact Assessment:

Bob Ledsome.

Bob Ledsome  
Deputy Director

6 December 2011

## Full Equality Impact Assessment – action plan

Actions taken or proposed	Rationale for the action	Beneficiaries of the action	Timing	Responsibility
<b>Changes made:</b> Changes that have been made to policy as a result of the Equality Impact Assessment.				
A decision has been made to pursue a voluntary approach to increase provision of Changing Place facilities.	To ensure a broader reach in terms of increased provision and an in-depth engagement amongst industry with the need for these facilities.	Older people; Groups with a physical disability or reduced mobility; women.	As part of 2013 review	DCLG to bring industry partners together.
<b>Mitigation:</b> For areas where a policy may have a differential impact on certain groups, what arrangements are in place or proposed to mitigate these effects?				
Formal public consultation in 2012 will allow affected groups to raise concerns over policy impacts before implementation.	Stakeholder engagement thus far has not raised concern at the suggested approach, but formal consultation will provide another route for engagement with key groups.	All affected groups.	Formal consultation January – April 2012	DCLG
<b>Justification:</b> For areas where a policy may impact negatively (but not illegally) on certain groups but mitigation is not possible (e.g. an overriding societal driver) there needs to be a strategy for handling issues of unfairness.				
NA				

Actions taken or proposed	Rationale for the action	Beneficiaries of the action	Timing	Responsibility
<b>Opportunities:</b> Please state actions designed to maximise positive effects, i.e. opportunities identified for: promoting equality, good relations or knowledge about groups; increasing civic and democratic participation; or addressing inequalities.				
Facilitating a group of external partners to work together to improve provision of Changing Places toilets.	A voluntary approach provides an opportunity to secure a long-term framework for delivering better provision of these facilities. It will bring together potential providers and representatives of those that would benefit most from better provision.	Older people; Groups with a physical disability or reduced mobility; women.	An initial meeting is planned for the first quarter of 2012 with the subsequent workplan to be agreed by that group.	DCLG to bring industry partners together.
<b>Monitor:</b> How will you monitor the impact and effectiveness of the new policy?				
Work closely with external partners to monitor the impact of the voluntary approach in practice.	To assess how effective a voluntary approach is at increasing provision of Changing Place facilities.	Older people; Groups with a physical disability or reduced mobility; women.	Ongoing.	DCLG/ Changing Places consortium.
<b>Publish:</b> Give details of how the results of the EqIA will be published.				
Full Equality Impact Assessment to be published on the DCLG website	In the interests of transparency.	Members of the public, external partners, local authorities, MPs and other interested parties.	TBC	DCLG

# Annex E

## Proposed amendments to Approved Document A

Page 4

### **EUROCODES**

*Delete existing text and insert the following*

#### **“EUROCODES**

The British Standards Institution notified the British Standards for structural design referenced in the 2004 edition of this Approved Document as withdrawn on 31 March 2010. British Standards for structural design based upon the Eurocodes were correspondingly implemented by the British Standards Institution on 1 April 2010 and it is these standards with their UK National Annexes which are now referenced in this Approved Document as practical guidance on meeting Part A requirements.

There may be alternative ways of achieving compliance with the requirements and there might be cases where the use of withdrawn standards no longer maintained by the British Standards Institution might be appropriate for meeting Part A requirements but their use would need to be justified. The Department will ensure further information on these withdrawn standards is made available.”

### **A1/2 Guidance**

Page 6

#### **Introduction**

*Delete existing paragraph 0.3 and insert the following:*

**“0.3** Grandstands and structures erected in places of public assembly may need to sustain the synchronous or rhythmic movement of numbers of people. It is important to ensure that the design of the structure takes these factors into account so as to avoid the structure being impaired or causing alarm to people using the structure.

Guidance on the design and testing of grandstands may be found in ‘*Dynamic performance requirements for permanent grandstands subject to crowd action – Recommendations for management, design and assessment*’ published by The Institution of Structural Engineers, December 2008.”



## **A1/2 SECTION 1: Codes, standards and references for all building types**

*Page 7*

*Delete all text from “Introduction” up to and including that in paragraph 1.8 and insert the following:*

### **“Introduction**

**1.1** This section is relevant to all building types and lists codes, standards and other references for structural design and construction.

### **References**

#### **1.2 Basis of structural design and loading:**

Eurocode: Basis of Structural Design

BS EN 1990:2002+A1:2005 Eurocode – Basis of structural design; with UK National Annex to BS EN 1990:2002+A1:2005

Eurocode 1: Actions on Structures

BS EN 1991-1-1:2002 Eurocode 1: Actions on structures – Part 1.1: General actions – Densities, self weight, imposed loads for buildings; with UK National Annex to BS EN 1991-1-1:2002

BSI PD 6688-1-1:2011 Published Document – Recommendations for the design of structures to BS EN 1991-1-1

BS EN 1991-1-3:2003 Eurocode 1: Actions on structures – Part 1.3: General actions – Snow loads; with UK National Annex to BS EN 1991-1-3:2003

BS EN 1991-1-4:2005+A1:2010 Eurocode 1: Actions on structures – Part 1.4: General actions – Wind actions; with UK National Annex to BS EN 1991-1-4:2005

BSI PD 6688-1-4:2009 Published Document – Background information to the National Annex to BS EN 1991-1-4 and additional guidance

BS EN 1991-1-5:2003 Eurocode 1: Actions on structures – Part 1.5: General actions – Thermal actions; with UK National Annex to BS EN 1991-1-5:2003

BS EN 1991-1-6:2005 Eurocode 1: Actions on structures – Part 1.6: General actions – Actions during execution; with UK National Annex to BS EN 1991-1-6:2005

BS EN 1991-1-7:2006 Eurocode 1: Actions on structures – Part 1.7: General actions – Accidental actions; with UK National Annex to BS EN 1991-1-7:2006

BSI PD 6688-1-7:2009 Published Document – Recommendations for the design of structures to BS EN 1991-1-7

BS EN 1991-3:2006 Eurocode 1: Actions on structures – Part 3: Actions induced by cranes and machines; with UK National Annex to BS EN 1991-3:2006

### **1.3 Structural work of reinforced, pre-stressed or plain concrete:**

Eurocode 2: Design of Concrete Structures

BS EN 1992-1-1:2004 Eurocode 2: Design of concrete structures – Part 1.1: General rules and rules for buildings; with UK National Annex to BS EN 1992-1-1:2004

BSI PD 6687-1:2010 Published Document – Background paper to the UK National Annexes to BS EN 1992-1 and BS EN 1992-3

BSI PD 6687-2:2008 Published Document – Recommendations for the design of structures to BS EN 1992-2:2005

BS EN 13670:2009 Execution of concrete structures

### **1.4 Structural work of steel:**

Eurocode 3: Design of Steel Structures

BS EN 1993-1-1:2005 Eurocode 3: Design of steel structures – Part 1.1: General rules and rules for buildings; with UK National Annex to BS EN 1993-1-1:2005

BS EN 1993-1-3:2006 Eurocode 3: Design of steel structures – Part 1.3: General rules – Supplementary rules for cold-formed members and sheeting; with UK National Annex to BS EN 1993-1-3:2006

BS EN 1993-1-4:2006 Eurocode 3: Design of steel structures – Part 1.4: General rules – Supplementary rules for stainless steels; with UK National Annex to BS EN 1993-1-4:2006

BS EN 1993-1-5:2006 Eurocode 3: Design of steel structures – Part 1.5: Plated structural elements; with UK National Annex to BS EN 1993-1-5:2006

BS EN 1993-1-6:2007 Eurocode 3: Design of steel structures – Part 1.6: Strength and stability of shell structures

BS EN 1993-1-7:2007 Eurocode 3: Design of steel structures – Part 1.7: Plated structures subject to out of plane loading

BS EN 1993-1-8:2005 Eurocode 3: Design of steel structures – Part 1.8: Design of joints; with UK National Annex to BS EN 1993-1-8:2005

BS EN 1993-1-9:2005 Eurocode 3: Design of steel structures – Part 1.9: Fatigue; with UK National Annex to BS EN 1993-1-9:2005

BSI PD 6695-1-9:2008 Published Document – Recommendations for the design of structures to BS EN 1993-1-9

BS EN 1993-1-10:2005 Eurocode 3: Design of steel structures – Part 1.10: Material toughness and through-thickness properties; with UK National Annex to BS EN 1993-1-10:2005

BSI PD 6695-1-10:2009 Published Document – Recommendations for the design of structures to BS EN 1993-1-10

BS EN 1993-1-11:2006 Eurocode 3: Design of steel structures – Part 1.11: Design of structures with tension components; with UK National Annex to BS EN 1993-1-11:2006

BS EN 1993-1-12:2007 Eurocode 3: Design of steel structures – Part 1.12: Additional rules for the extension of EN 1993 up to steel grades S 700; with UK National Annex to BS EN 1993-1-12:2007

BS EN 1993-5: Piling:2007 Eurocode 3: Design of steel structures – Part 5: Piling; with UK National Annex to BS EN 1993-5:2007

BS EN 1993-6:2007 Eurocode 3: Design of steel structures – Part 6: Crane supporting structures; with UK National Annex to BS EN 1993-6:2007

BS EN 1090-2:2008+A1:2011 Execution of steel structures and aluminium structures – Part 2. Technical requirements for the execution of steel structures

BRE Digest 437 Industrial platform floors: mezzanine and raised storage

## **1.5 Structural work of composite steel and concrete:**

Eurocode 4: Design of Composite Steel and Concrete Structures

BS EN 1994-1-1:2004 Eurocode 4: Design of composite steel and concrete structures – Part 1.1: General rules and rules for buildings; with UK National Annex to BS EN 1994-1-1:2004

## **1.6 Structural work of timber:**

Eurocode 5: Design of Timber Structures

BS EN 1995-1-1:2004+A1:2008 Eurocode 5: Design of timber structures – Part 1.1: General – Common rules and rules for buildings; with UK National Annex to BS EN 1995-1-1:2004+A1:2008

BSI PD 6693-1-1:2012 Published Document – Recommendations for the design of timber structures to BS EN 1995-1-1 (to be published by BSI in 2012)

BS 8103-3:2009 Structural design of low-rise buildings – Part 3: Code of practice for timber floors and roofs for housing

### **1.7 Structural work of masonry:**

Eurocode 6: Design of Masonry Structures

BS EN 1996-1-1:2005 Eurocode 6: Design of masonry structures – Part 1.1: General rules for reinforced and unreinforced masonry structures; with UK National Annex to BS EN 1996-1-1:2005

BS EN 1996-2:2006 Eurocode 6: Design of masonry structures – Part 2: Design considerations, selection of materials and execution of masonry; with UK National Annex to BS EN 1996-2:2006

BSI PD 6697:2010 Published Document – Recommendations for the design of masonry structures to BS EN 1991-1-1 and BS EN 1996-2

BS EN 1996-3:2006 Eurocode 6: Design of masonry structures – Part 3: Simplified calculation methods for unreinforced masonry structures; with UK National Annex to BS EN 1996-3:2006

BS 8103-1:2011 Structural design of low-rise buildings – Part 1: Code of Practice for stability, site investigation, foundations, precast concrete floors and ground floor slabs for housing

BS 8103-2:2005 Structural design of low-rise buildings – Part 2: Code of practice for masonry walls for housing

### **1.8 Geotechnical work and foundations:**

Eurocode 7: Geotechnical Design

BS EN 1997-1:2004 Eurocode 7: Geotechnical design – Part 1: General rules; with UK National Annex to BS EN 1997-1:2004

BS EN 1997-2:2007 Eurocode 7: Geotechnical design – Part 2: Ground investigation and testing; with UK National Annex to BS EN 1997-2:2007

### **1.9 Seismic aspects:**

Eurocode 8: Design of Structures for Earthquake Resistance

BS EN 1998-1:2004 Eurocode 8: Design of structures for earthquake resistance – Part 1. General rules, seismic actions and rules for buildings; with UK National Annex to BS EN 1998-1:2004

BS EN 1998-5:2004 Eurocode 8: Design of structures for earthquake resistance – Part 5. Foundations, retaining structures and geotechnical aspects; with UK National Annex to BS EN 1998-2:2004

BSI PD 6698:2009 Published Document – Recommendations for the design of structures for earthquake resistance to BS EN 1998

### **1.10 Structural work of aluminium:**

Eurocode 9: Design of Aluminium Structures

BS EN 1999-1-1:2007+A1:2009 Eurocode 9: Design of aluminium structures – Part 1.1: General structural rules; with UK National Annex to BS EN 1999-1-1:2007+A1:2009

BS EN 1999-1-3:2007+A1:2011 Eurocode 9: Design of aluminium structures – Part 1.3: Structures susceptible to fatigue; with UK National Annex to BS EN 1999-1-3:2007

BSI PD 6702-1:2009 Published Document – Structural use of aluminium – Part 1. Recommendations for the design of aluminium structures to BS EN 1999

BS EN 1999-1-4:2007+A1:2011 Eurocode 9: Design of aluminium structures – Part 1.4: Cold-formed structural sheeting; with UK National Annex to BS EN 1999-1-4:2007

BS EN 1999-1-5:2007 Eurocode 9: Design of aluminium structures – Part 1.5: Shell structures; with UK National Annex to BS EN 1999-1-5:2007

BS EN 1090-3:2008 Execution of steel structures and aluminium structures – Part 3. Technical requirements for aluminium structures

BSI PD 6705-3:2009 Published Document – Structural use of steel and aluminium – Part 3. Recommendations for the execution of aluminium structures to BS EN 1090-3”

*Page 8*

#### **Ground movement (Requirement A2b)**

*Change paragraph numbering:*

Replace “**1.9**” with “**1.11**”

*Page 8*

#### **Existing buildings**

*Change paragraph numbering:*

Replace “**1.10**” with “**1.12**”

Page 8

### **Existing buildings**

*Delete existing paragraph 1.10b. and insert the following:*

“1.12b. The Institution of Structural Engineers Technical Publication ‘Appraisal of existing structures (Third edition), 2010’

Note: With reference to ‘design checks’ in the referenced Institution of Structural Engineers’ Technical Publication the choice of various partial factors should be made to suit the individual circumstances of each case.”

### **A1/2 Section 2A: Basic requirements for stability**

Page 10

**2A2** sub paragraph d. “Note:”

*Delete existing text and insert the following:*

“Note: A traditional cut timber roof (i.e. using rafters, purlins and ceiling joists) generally has sufficient built in resistance to instability and wind forces (e.g. from hipped ends, tiling battens, rigid sarking or the like). However, the need for diagonal rafter bracing equivalent to that recommended in BS EN 1995-1-1:2004 with its UK National Annex and additional guidance given in BSI Published Document PD 6693-1-1:2012 and BS 8103-3:2009 for trussed rafter roofs should be considered, especially for single-hipped and non-hipped roofs of greater than 40° pitch to detached houses.”

### **A1/2 Section 2B: sizes of certain timber members in floors and roofs for dwellings. Areas at risk from house longhorn beetle**

#### **Sizing of members**

Page 11

**2B1**

*Delete existing text and insert the following:*

“Guidance on the sizing of certain members in floors and roofs is given in ‘Span tables for solid timber members in floors, ceilings and roofs (excluding trussed rafter roofs) for dwellings’, published by TRADA, available from Chiltern House, Stocking Lane, Hughenden Valley, High Wycombe, Bucks HP14 4ND.

Alternative guidance is available in BS EN 1995-1-1:2004 Design of timber structures, General – common rules and rules for buildings with its UK National Annex and BS 8103-3:2009 Structural design of low-rise buildings, Code of practice for timber floors and roofs for housing.”

## House longhorn beetle

Page 11

**2B2** second paragraph

*Delete existing text and insert the following:*

“Guidance on suitable preservative treatments is given within The Wood Protection Association’s manual ‘Industrial Wood Preservation Specification and Practice (2011)’, available from 5C Flemming Court, Castleford, West Yorkshire, WF10 5HW.”

## A1/2 Section 2C: Thickness of walls in certain small buildings

### The use of this section

Page 12

**2C3** sub paragraph c.

*Delete existing text and insert the following:*

“c. walls should comply with the relevant requirements of BS EN 1996-2:2006 with its UK National Annex and additional guidance given in BSI Published Document PD 6697:2010, except as regards the conditions given in paragraphs **2C4** and **2C14** to **2C38**.”

Page 12

**2C3** sub paragraph e. second paragraph

*Delete existing text and insert the following:*

“BS EN 1996-1-1:2005 with its UK National Annex gives design strengths for walls where the suitability for use of masonry units of other compressive strengths is being considered.”

### Thickness of walls

Page 13,

**2C8**

*Delete existing text and insert the following)*

**“2C8 Cavity walls in coursed brickwork or blockwork:** All cavity walls should have leaves at least 90mm thick and cavities at least 50mm wide. The wall ties should have a horizontal spacing of 900mm and a vertical spacing of 450mm, or alternatively should be spaced such that the number of wall ties per square metre is not less than 2.5 ties/m<sup>2</sup>. Wall ties should also be provided, spaced not more than 300mm apart vertically, within a distance of 225mm from the vertical edges of all openings, movement joints and roof verges. For selection of wall ties for use in a range of cavity widths refer to Table 5. For specification of cavity wall ties refer to paragraph 2C19.”

Page 16

### 2C13

Delete existing text and insert the following:

**“2C13 Modular bricks and blocks:** Where walls are constructed of bricks or blocks having modular dimensions, wall thicknesses prescribed in this section which derive from a dimension of brick or block may be reduced by an amount not exceeding the deviation from work size permitted by a British Standard relating to equivalent sized bricks or blocks made of the same material.”

Page 16

### 2C16

Delete existing text and insert the following:

**“2C16 Maximum height of buildings:** The design guidance in this section is based on BS EN 1991-1-4:2005 with its UK National Annex. The maximum heights of buildings given in Table c of Diagram 7 correlate to various site exposure conditions and wind speeds. A map showing wind speeds is given in Figure 1 of Diagram 6.”

## Construction materials and workmanship

Page 17

### 2C19

Delete existing text and insert the following:

**“2C19 Wall ties:** Wall ties should comply with BS EN 845-1 and should be material references 1 or 3 in BS EN 845-1 Table A1 austenitic stainless steel. Wall ties should be selected in accordance with Table 5 of this Approved Document.”

Page 17

### 2C20

Delete existing text and insert the following:

**“2C20 Masonry units:** Walls should be properly bonded and solidly put together with mortar and constructed of masonry units conforming to:

- a. clay bricks or blocks to BS EN 771-1;
- b. calcium silicate bricks or blocks to BS EN 771-2;
- c. concrete bricks or blocks to BS EN 771-3 or BS EN 771-4;
- d. manufactured stone to BS EN 771-5;
- e. square dressed natural stone to the appropriate requirements described in BS EN 771-6.”



Pages 18-19,

Diagram 6

Delete the existing Diagram 6 and insert the following:

**Diagram 6 Map showing wind speeds in m/s for maximum height of buildings**

See para 2C16

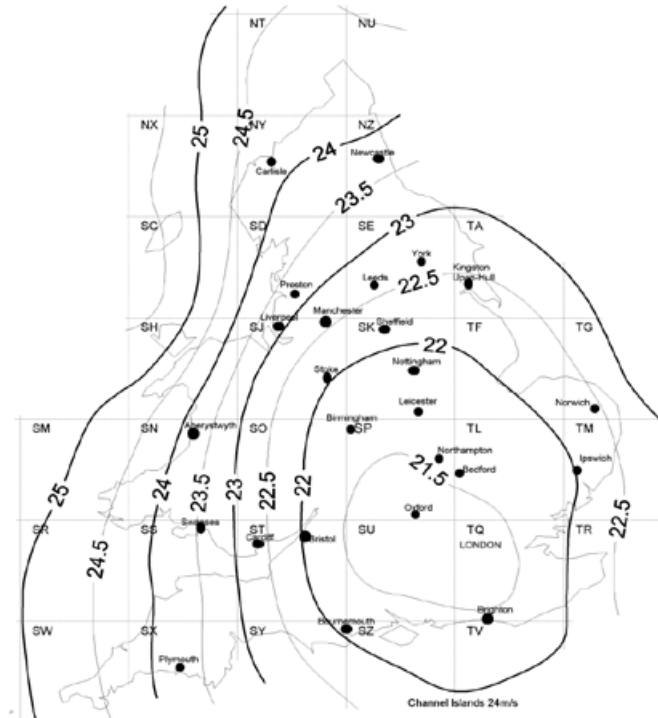

Figure 1 Map of wind speeds (V) in m/s

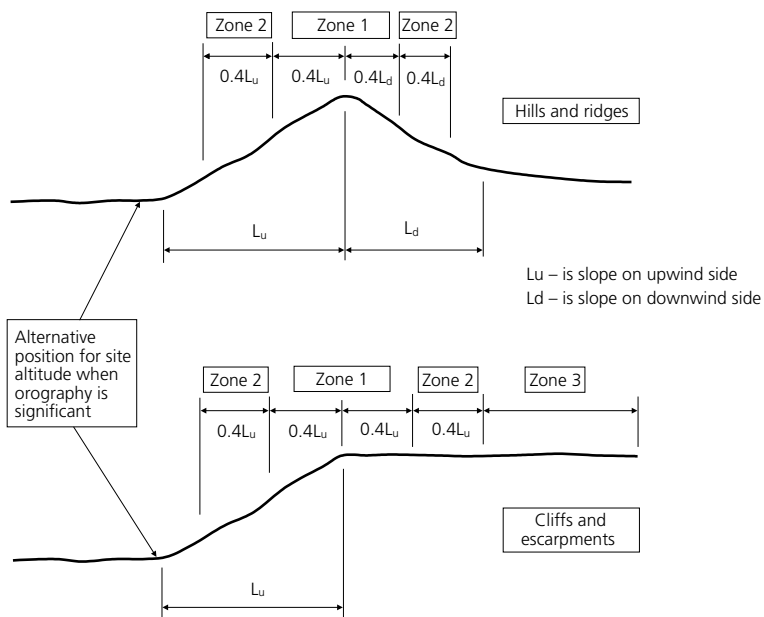
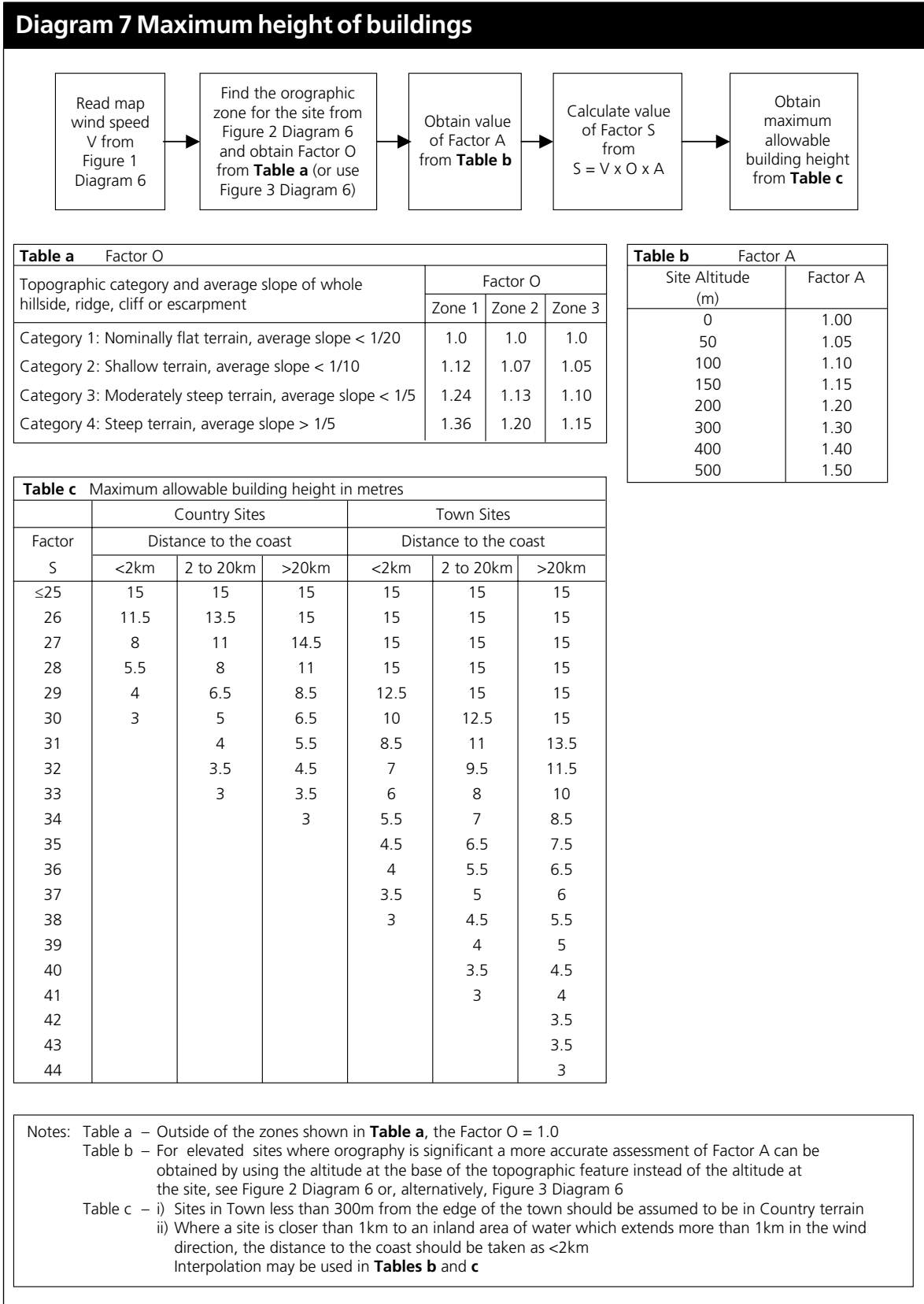

Figure 2 Orographic zones for Factor O

Note: A more detailed approach for obtaining Factor O is given by Figure 3 Diagram 6

Pages 18-19, Diagram 7

Delete the existing Diagram 7 and insert the following:



Pages 18-19, Diagram 6  
 Add new Figure 3 to Diagram 6

**Diagram 6 Map showing wind speeds in m/s for maximum height of buildings**

**Figure 3 Alternative graphical method for determining orography Factor O**

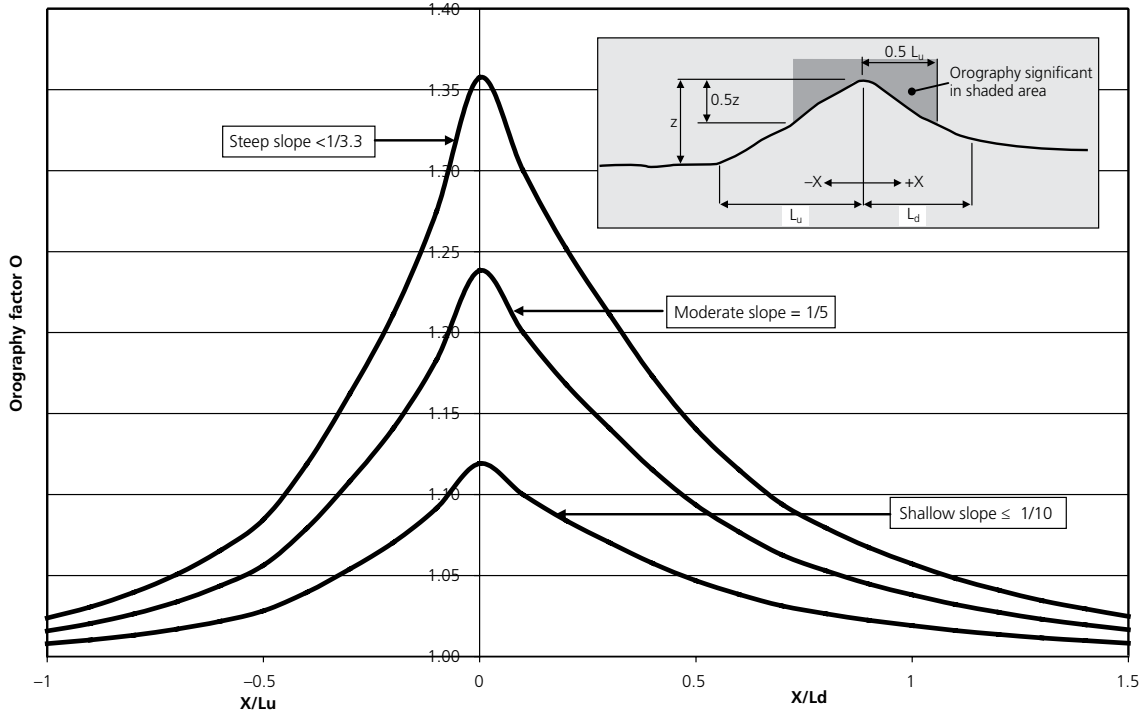

Figure 3a Orography Factor O for hills and ridges  
 (interpolation between curves may be used)

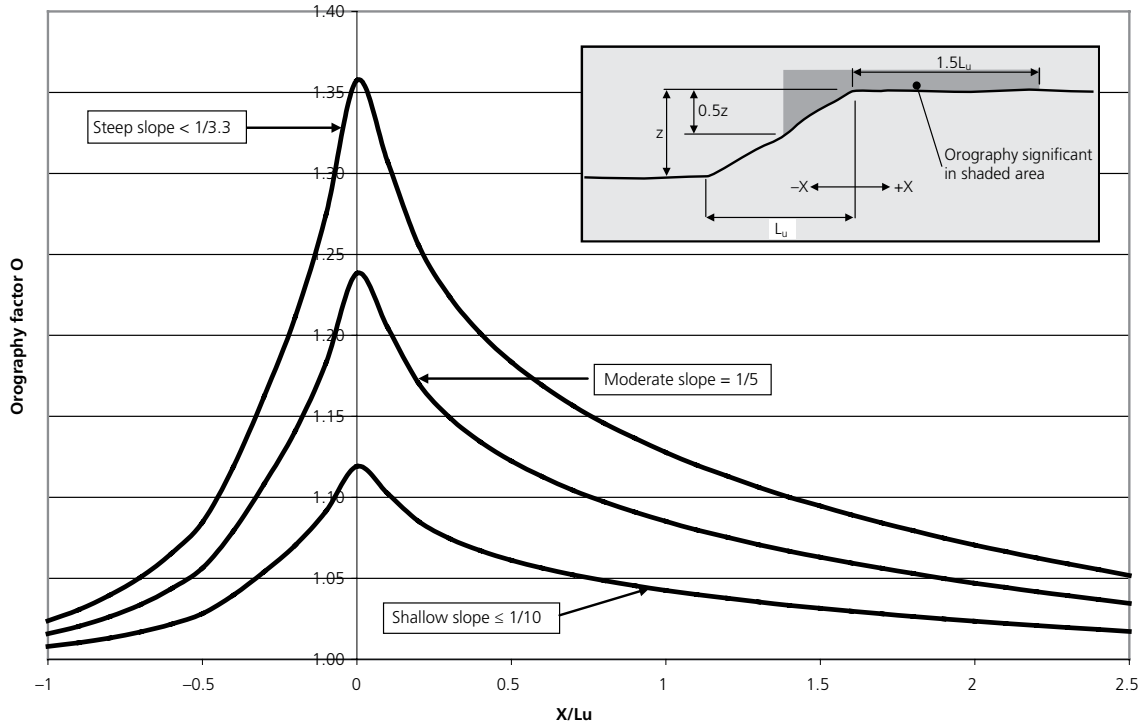

Figure 3b Orography Factor O for cliffs and escarpments  
 (interpolation between curves may be used)

Page 21

Table 5 **Cavity wall ties**

Delete the existing Table 5 and insert the following:

Table 5 <b>Cavity wall ties</b>		
<b>Nominal cavity width mm (Note 1)</b>	<b>Tie length mm (Note 2)</b>	<b>BS EN 845-1 wall tie</b>
50 to 75	200	Type 1, 2, 3 or 4 to PD 6697:2010 and selected on the basis of the design loading and design cavity width.
76 to 100	225	
101 to 125	250	
126 to 150	275	
151 to 175	300	
176 to 300	(See Note 2)	

**Notes:**

1. Where face insulated blocks are used the cavity width should be measured from the face of the masonry unit.
2. The embedment depth of the tie should not be less than 50mm in both leaves. For cavities wider than 175mm calculate the length as the nominal cavity width plus 125mm and select the nearest stock length. For wall ties requiring embedment depths in excess of 50 mm, increase the calculated tie length accordingly.

Page 23

**2C22**

Delete existing text and insert the following:

**"2C22 Mortar:** Mortar should be:

- a.
  - i. Mortar designation (iii) according to BS EN 1996-1-1:2005 with its UK National Annex;
  - ii. Strength class M4 according to BS EN 998-2;
  - iii. 1:1:5 to 6 CEM I, lime, and fine aggregate measured by volume of dry materials, or
- b. of equivalent or greater strength and durability to the specification in a. above."

## Lateral support by roofs and floors

Page 27

Diagram 14 **Sizes of openings and recesses, Note 8**

Delete existing text and insert the following:

**“Note 8** Take the value of the factor X from Table 8, or it can be given the value 6, provided the compressive strength of the bricks or blocks (in the case of a cavity wall – in the loaded leaf) is not less than 7N/mm<sup>2</sup>.”

Page 28

**2C35** sub paragraph b.

Delete existing text and replace with the following:

**“2C35** b. in the longitudinal direction of joists in houses of not more than 2 storeys, if the joists are carried on the supported wall by joist hangers in accordance with BS EN 845-1 of the restraint type described by additional guidance given in BSI Published Document PD 6697:2010 and shown in Diagram 15(c), and are incorporated at not more than 2m centres, and”

## Small single-storey non-residential buildings and annexes

Page 30

**2C38 Size and proportion i. General** sub paragraph h.

Delete existing text and insert the following:

**“2C38** h. The roof is braced at rafter level, horizontally at eaves level and at the base of any gable by roof decking, rigid sarking or diagonal timber bracing, as appropriate, in accordance with BS EN 1995-1-1:2004 with its UK National Annex and additional guidance given in BSI Published Document PD 6693-1-1:2012 or BS 8103-3:2009.”

Page 32

Diagram 19 **Lateral restraint at roof level, Key** Note:

Delete existing text and insert the following:

**“Note:** Fixings should be in accordance with Diagram 16”

## A1/2 Section 2E: Foundations of plain concrete

### Minimum depth of strip foundations

Page 35

#### 2E4

Delete existing text and insert the following:

**2E4** Except where strip foundations are founded on rock, the strip foundations should have a minimum depth of 0.45m to their underside to avoid the action of frost. This depth, however, will commonly need to be increased in areas subject to long periods of frost or in order to transfer the loading onto satisfactory ground.

In clay soils subject to volume change on drying ('shrinkable clays', with Modified Plasticity Index greater than or equal to 10%), strip foundations should be taken to a depth where anticipated ground movements will not impair the stability of any part of the building taking due consideration of the influence of vegetation and trees on the ground. The depth to the underside of foundations on clay soils should not be less than 0.75m on low shrinkage clay soils, 0.9m on medium shrinkage clay soils and 1.0m on high shrinkage clay soils, although these depths will commonly need to be increased in order to transfer the loading onto satisfactory ground, or where there are trees nearby."

## A1/2 Section 3: Wall cladding

Page 36

### Loading

Delete existing 3.3, 3.4, 3.5 and 3.6 and insert the following):

**3.3** Wind loading on the cladding should be derived from BS EN 1991-1-4:2005 with its UK National Annex with due consideration given to local increases in wind suction arising from funnelling of the wind through gaps between buildings.

**3.4** Where the cladding is required to support other fixtures, e.g. handrails, and fittings, e.g. antennae and signboards, account should be taken of the loads and forces arising from such fixtures and fittings.

**3.5** Where the wall cladding is required to function as pedestrian guarding to stairs, ramps, vertical drops of more than 600mm in dwellings or more than the height of two risers (or 380mm if not part of a stair) in other buildings, or as a vehicle barrier, then account should be taken of the additional imposed loading, as stipulated in Approved Document K, Protection from falling, collision and impact.

**3.6** Where the wall cladding is required to safely withstand lateral pressures from crowds, an appropriate design loading is given in BS EN 1991-1-1:2002 with its UK National Annex and the Guide to Safety at Sports Grounds (4th Edition, 1997). "

## **A1/2 Section 4: Roof covering**

*Page 38*

### **Materials and Re-covering of roofs**

*Delete existing 4.1, 4.4 and 4.7 identified texts only and insert the following:*

"**4.1** All materials used to cover roofs, including transparent or translucent materials, but excluding windows of glass in residential buildings with roof pitches of not less than 15°, shall be capable of safely withstanding the concentrated imposed loading upon roofs specified in BS EN 1991-1-1:2002 with its UK National Annex.

**4.4** A significant change in roof loading is when the loading upon the roof is either increased or decreased by more than 15% from its original condition.

**4.7** Where work will decrease the roof dead loading by more than 15% from its original condition, the roof structure and its anchorage to the supporting structure should be checked to ensure that an adequate factor of safety is maintained against uplift of the roof under imposed wind loading."

## **A3 Section 5: Reducing the sensitivity of the building to disproportionate collapse in the event of an accident**

*Pages 41-42*

*Delete existing Section 5 inclusive of paragraphs 5.1 to 5.4, Table 11 and Diagram 24 and insert the following:*

"**5.1** The requirement will be met by adopting the following approach for ensuring that the building is sufficiently robust to sustain a limited extent of damage or failure, depending on the class of the building, without collapse.

**a.** Determine the building Consequence Class from Table 11.

**b. For Consequence Class 1 buildings** – Provided the building has been designed and constructed in accordance with the rules given in this Approved Document, or other guidance referenced under Section 1, for meeting compliance with requirement A1 and A2 in normal use, no additional measures are likely to be necessary.

**c. For Consequence Class 2a buildings** – In addition to the Consequence Class 1 measures, provide effective horizontal ties, or effective anchorage of suspended floors to walls, as described in the Standards listed under paragraph 5.2 for framed and load-bearing wall construction (the latter being defined in paragraph 5.3 below).

**d. For Consequence Class 2b buildings** – In addition to the Consequence Class 1 measures, provide effective horizontal ties, as described in the Standards listed under paragraph 5.2 for framed and load-bearing wall construction (the latter being defined in paragraph 5.3 below), together with effective vertical ties, as defined in the Standards listed under paragraph 5.2, in all supporting columns and walls.

**Table 11 Building classes**

Consequence Class	Building type and occupancy
1	Houses not exceeding 4 storeys Agricultural buildings Buildings into which people rarely go, provided no part of the building is closer to another building, or area where people do go, than a distance of 1.5 times the building height
2a Lower Risk Group	5 storey single occupancy houses Hotels not exceeding 4 storeys Flats and other residential buildings not exceeding 4 storeys Offices not exceeding 4 storeys Industrial buildings not exceeding 3 storeys Retailing premises not exceeding 3 storeys of less than 2000m <sup>2</sup> floor area in each storey Single-storey educational buildings All buildings not exceeding 2 storeys to which members of the public are admitted and which contain floor areas not exceeding 2000m <sup>2</sup> at each storey



<b>Table 11 Building classes (continued)</b>	
2b Upper Risk Group	Hotels, blocks of flats, apartments and other residential buildings greater than 4 storeys but not exceeding 15 storeys Educational buildings greater than 1 storey but not exceeding 15 storeys Retailing premises greater than 3 storeys but not exceeding 15 storeys Hospitals not exceeding 3 storeys Offices greater than 4 storeys but not exceeding 15 storeys All buildings to which members of the public are admitted which contain floor areas exceeding 2000m <sup>2</sup> but less than 5000m <sup>2</sup> at each storey Car parking not exceeding 6 storeys
3	All buildings defined above as Consequence Class 2a and 2b that exceed the limits on area and/or number of storeys Grandstands accommodating more than 5000 spectators Buildings containing hazardous substances and/or processes
<p><b>Notes:</b></p> <ol style="list-style-type: none"> <li>1. For buildings intended for more than one type of use the Consequence Class should be that pertaining to the most onerous type</li> <li>2. In determining the number of storeys in a building, basement storeys may be excluded provided such basement storeys fulfil the requirements of Consequence Class 2b</li> <li>3. BS EN 1991-1-7:2006 with its UK National Annex also provides compatible guidance to Table 11</li> </ol>	

Alternatively, check that upon the notional removal of each supporting column and each beam supporting one or more columns, or any nominal length of load-bearing wall (one at a time in each storey of the building), the building remains stable and that the area of floor at any storey at risk of collapse does not exceed 15% of the floor area of that storey or 100m<sup>2</sup>, whichever is smaller, and does not extend further than the immediate adjacent storeys (see Diagram 24).

Where the notional removal of such columns and lengths of walls would result in an extent of damage in excess of the above limit, then such elements should be designed as a 'key element' as defined in paragraph 5.3 below.

**e. For Consequence Class 3 buildings** – A systematic risk assessment of the building should be undertaken taking into account all the normal hazards that may reasonably be foreseen, together with any abnormal hazards.

Critical situations for design should be selected that reflect the conditions that can reasonably be foreseen as possible during the life of the building. The structural form and concept and any protective measures should then be chosen and the detailed design of the structure and its elements undertaken in accordance with the recommendations given in the Standards given in paragraph **5.2**.

Further guidance is given in Annexes A and B to BS EN1991-1-7:2006 Eurocode 1: Actions on structures – Part 1.7: General actions – Accidental actions; with UK National Annex to BS EN 1991-1-7:2006 and BS EN 1990:2002+A1:2005 Eurocode – Basis of structural design; with UK National Annex to BS EN 1990:2002+A1:2005.

**5.2** Details of the effective horizontal and vertical ties including tie force determination, together with the design approaches for checking the integrity of the building following the notional removal of vertical members and the design of key elements, are given in the following Standards:

BS EN 1990 :2002+A1:2005 Eurocode – Basis of structural design; with UK National Annex to BS EN 1990 :2002+A1:2005

BS EN 1991-1-7 :2006 Eurocode 1 : Actions on structures – Part 1.7 : General actions – Accidental actions ; with UK National Annex to BS EN 1991-1-7 :2006

BS EN 1992-1-1:2004 Eurocode 2: Design of concrete structures – Part 1.1: General rules and rules for buildings; with UK National Annex to BS EN 1992-1-1:2004

BS EN 1993-1-1:2005 Eurocode 3: Design of steel structures – Part 1.1: General rules and rules for buildings; with UK National Annex to BS EN 1993-1-1:2005

BS EN 1994-1-1:2004 Eurocode 4: Design of composite steel and concrete structures – Part 1.1: General rules and rules for buildings; with UK National Annex to BS EN 1994-1-1:2004

BS EN 1995-1-1:2004+A1:2008 Eurocode 5: Design of timber structures – Part 1.1: General – Common rules and rules for buildings; with UK National Annex to BS EN 1995-1-1:2004+A1:2008

BS EN 1996-1-1:2005 Eurocode 6: Design of masonry structures – Part 1.1: General rules for reinforced and unreinforced masonry structures; with UK National Annex to BS EN 1996-1-1:2005

BS EN 1999-1-1:2007+A1:2009 Eurocode 9: Design of aluminium structures – Part 1.1: General structural rules; with UK National Annex to BS EN 1999-1-1:2007+A1:2009

## 5.3 Definitions

### Nominal length of load-bearing wall

The nominal length of load-bearing wall construction referred to in **5.1d** should be taken as follows:

- in the case of a reinforced concrete wall, the distance between lateral supports subject to a maximum length not exceeding  $2.25H$ .
- in the case of an external masonry wall, or timber or steel stud wall, the length measured between vertical lateral supports.
- in the case of an internal masonry wall, or timber or steel stud wall, a length not exceeding  $2.25H$ .
- where  $H$  is the storey height in metres.

Note: Annex A of BS EN 1991-1-7:2006 with its UK National Annex provides corresponding guidance.

### Key elements

A 'key element', as referred to in paragraph **5.1d**, should be capable of sustaining an accidental design loading of  $34\text{kN/m}^2$  applied in the horizontal and vertical directions (in one direction at a time) to the member and any attached components (e.g. cladding etc.) having regard to the ultimate strength of such components and their connections. Such accidental design loading should be assumed to act simultaneously with all normal characteristic loading (i.e. wind and other imposed loading).

Note: Annex A of BS EN 1991-1-7:2006 with its UK National Annex provides corresponding guidance for 'key elements'.

BS EN 1990:2002+A1:2005 with its UK National Annex provides guidance on accidental design loading application for 'key elements' and expression 6.11b of that standard is relevant.

### Load-bearing construction

For the purposes of this Guidance the term 'load-bearing wall construction' includes masonry cross-wall construction and walls comprising close centred timber or lightweight steel section studs.

## Alternative approach

**5.4** As an alternative to Table 11, for any building which does not fall into the classes listed under Table 11, or for which the consequences of collapse may warrant particular examination of the risks involved, performance may be met by following the recommendations given in the following Reports and Publication:

*'Guidance on Robustness and Provision against Accidental Actions'*, dated July 1999.

*'Calibration of Proposed Revised Guidance on meeting Compliance with the requirements of Building Regulation Part A3'*. Revision of the Allott and Lomax proposals. Project Report No. 205966.

Both of the above documents are available on the DCLG web site [www.communities.gov.uk](http://www.communities.gov.uk)

*'Practical Guide to Structural Robustness and Disproportionate Collapse in Buildings'* dated October 2010. Published by The Institution of Structural Engineers, London."

Page 42

*Insert the following new sub title and paragraph 5.5:*

### **"Seismic design**

**5.5** Seismic design is not usually required for buildings classified by Table 11 as being in Consequence Classes 1 and 2. For buildings classified as Consequence Class 3 the risk assessment should consider if there is any need to carry out seismic design, although such a need is not an explicit requirement for these buildings."

Page 43

Diagram 24 **Area at risk of collapse in the event of an accident**

*Insert the following:*

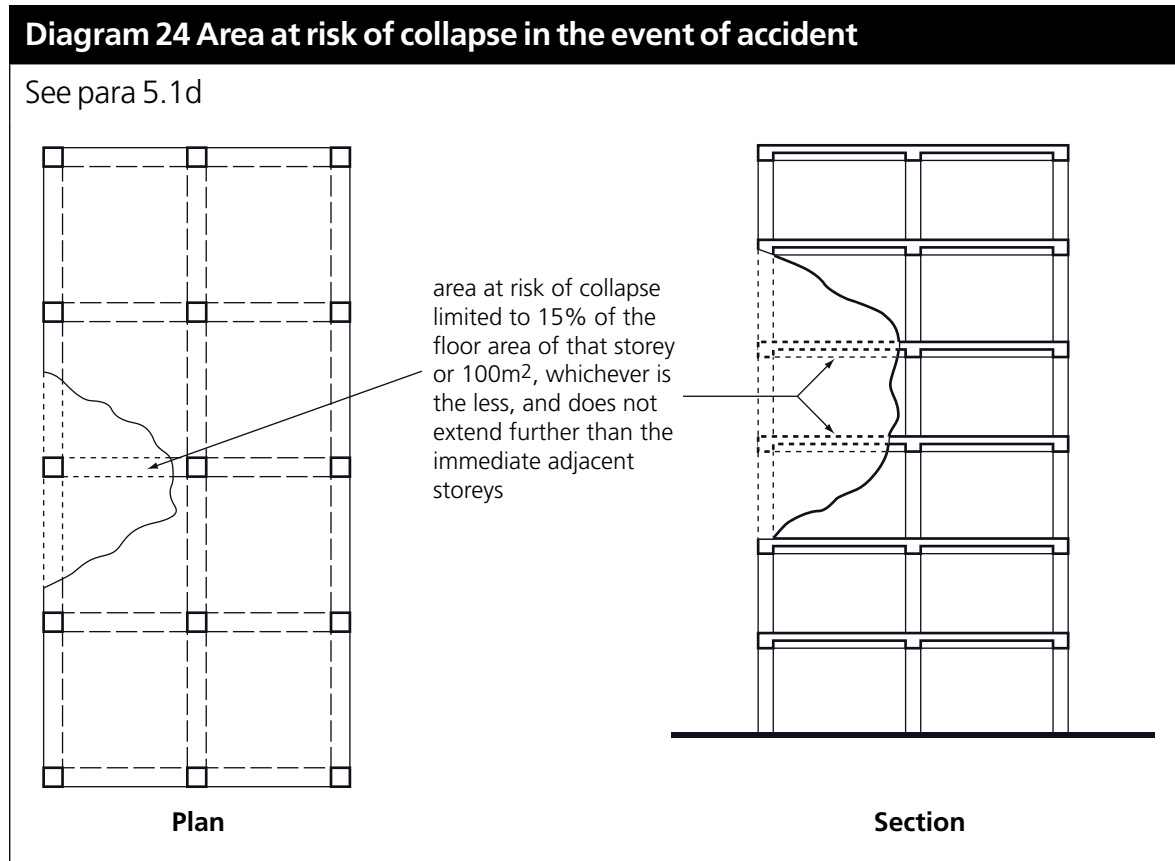

Pages 44-45

**A Standards referred to**

*Delete the reference list and insert the following:*

**"A1/2**

**BS 5080-1:1993**

Structural fixings in concrete and masonry. Method of test for tensile loading.

**BS 8103-1:2011**

Structural design of low-rise buildings. Code of practice for stability, site investigation, foundations, precast concrete floors and ground floor slabs for housing.

**BS 8103-2:2005**

Structural design of low-rise buildings. Code of practice for masonry walls for housing.

**BS 8103-3:2009**

Structural design of low-rise buildings. Code of practice for timber floors and roofs for housing.

**BS 8297:2000**

Code of practice for design and installation of non-loadbearing precast concrete cladding. AMD 11064 2000, AMD 13018 2000.

**BS 8298:1994**

Code of practice for design and installation of natural stone cladding and lining.

**BS 8500-1:2002**

Concrete. Complementary British Standard to BS EN 206-1. Method of specifying and guidance for the specifier. AMD 14639 2003.

**BS 8500-2:2002**

Concrete. Complementary British Standard to BS EN 206-1. Specification for constituent materials and concrete. AMD 14640 2003.

**BS EN 197-1:2000**

Cement. Composition, specifications and conformity criteria for common elements. AMD 15209 2004.

**BS EN 197-2:2000**

Cement. Conformity evaluation.

**BS EN 771-1:2003**

Specification for masonry units. Clay masonry units. AMD 15998 2005.

**BS EN 771-2:2001**

Specification for masonry units. Calcium silicate masonry units. (Withdrawn and superseded by BS EN 771-2:2003 Specification for masonry units. Calcium silicate masonry units. AMD 15974 2005.)

**BS EN 771-3:2003**

Specification for masonry units. Aggregate concrete masonry units (dense and light-weight aggregates).

**BS EN 771-4:2001**

Specification for masonry units. Autoclaved aerated concrete masonry units. (Withdrawn and superseded by BS EN 771-4:2003 Specification for masonry units. Autoclaved aerated concrete masonry units. AMD 16000 2005.)

**BS EN 771-5:2003**

Specification for masonry units. Manufactured stone masonry units. AMD 15999 2005.

**BS EN 771-6:2001**

Specification for masonry units. Natural stone masonry units. (Withdrawn and superseded by BS EN 771-6:2005 Specification for masonry units. Natural stone masonry units.)

**BS EN 845-1:2001**

Specification for ancillary components for masonry. Ties, tension straps, hangers and brackets. (Withdrawn and superseded by BS EN 845-1:2003 Specification for ancillary components for masonry. Ties, tension straps, hangers and brackets. AMD 14736 2003.)

**BS EN 845-2:2001**

Specification for ancillary components for masonry. Lintels. (Withdrawn and superseded by BS EN 845-2:2003 Specification for ancillary components for masonry. Lintels.)

**BS EN 845-3:2001**

Specification for ancillary components for masonry. Bed joint reinforcement of steel meshwork. (Withdrawn and superseded by BS EN 845-3:2003 Specification for ancillary components for masonry. Bed joint reinforcement of steel meshwork.)

**BS EN 998-2:2002**

Specification for mortar for masonry. Masonry mortar. (Withdrawn and superseded by BS EN 998-2:2003 Specification for mortar for masonry. Masonry mortar.)

**BS EN 1090-2:2008+A1:2011**

Execution of steel structures and aluminium structures – Part 2. Technical requirements for the execution of steel structures.

**BS EN 1090-3:2008**

Execution of steel structures and aluminium structures – Part 3. Technical requirements for aluminium structures.

**BS EN 1990:2002+A1:2005**

Eurocode – Basis of structural design; with UK National Annex to BS EN 1990:2002+A1:2005.

**BS EN 1991-1-1:2002**

Eurocode 1: Actions on structures – Part 1.1: General actions – Densities, self weight, imposed loads for buildings; with UK National Annex to BS EN 1991-1-1:2002.

**BS EN 1991-1-3:2003**

Eurocode 1: Actions on structures – Part 1.3: General actions – Snow loads; with UK National Annex to BS EN 1991-1-3:2003.

**BS EN 1991-1-4:2005+A1:2010**

Eurocode 1: Actions on structures – Part 1.4: General actions – Wind actions; with UK National Annex to BS EN 1991-1-4:2005+A1:2010.

**BS EN 1991-1-5:2003**

Eurocode 1: Actions on structures – Part 1.5: General actions – Thermal actions; with UK National Annex to BS EN 1991-1-5:2003.

**BS EN 1991-1-6:2005**

Eurocode 1: Actions on structures – Part 1.6: General actions – Actions during execution; with UK National Annex to BS EN 1996-1-6:2005.

**BS EN 1991-1-7:2006**

Eurocode 1: Actions on structures – Part 1.7: General actions – Accidental actions; with UK National Annex to BS EN 1991-1-7:2006.

**BS EN 1991-3:2006**

Eurocode 1: Actions on structures – Part 3: Actions induced by cranes and machines; with UK National Annex to BS EN 1991-3:2006.

**BS EN 1992-1-1:2004**

Eurocode 2: Design of concrete structures – Part 1.1: General rules and rules for buildings; with UK National Annex to BS EN 1992-1-1:2004.

**BS EN 1993-1-1:2005**

Eurocode 3: Design of steel structures – Part 1.1: General rules and rules for buildings; with UK National Annex to BS EN 1993-1-1:2005.

**BS EN 1993-1-3:2006**

Eurocode 3: Design of steel structures – Part 1.3: General rules – Supplementary rules for cold-formed members and sheeting; with UK National Annex to BS EN 1993-1-3:2006.

**BS EN 1993-1-4:2006**

Eurocode 3: Design of steel structures – Part 1.4: General rules – Supplementary rules for stainless steels; with UK National Annex to BS EN 1993-1-4:2006.

**BS EN 1993-1-5:2006**

Eurocode 3: Design of steel structures – Part 1.5: Plated structural elements; with UK National Annex to BS EN 1993-1-5:2006.

**BS EN 1993-1-6:2007**

Eurocode 3: Design of steel structures – Part 1.6: Strength and stability of shell structures.



**BS EN 1993-1-7:2007**

Eurocode 3: Design of steel structures – Part 1.7: Plated structures subject to out of plane loading

**BS EN 1993-1-8:2005**

Eurocode 3: Design of steel structures – Part 1.8: Design of joints; with UK National Annex to BS EN 1993-1-8:2005.

**BS EN 1993-1-9:2005**

Eurocode 3: Design of steel structures – Part 1.9: Fatigue; with UK National Annex to BS EN 1993-1-9:2005.

**BS EN 1993-1-10:2005**

Eurocode 3: Design of steel structures – Part 1.10: Material toughness and through-thickness properties; with UK National Annex to BS EN 1993-1-10:2005.

**BS EN 1993-1-11:2006**

Eurocode 3: Design of steel structures – Part 1.11: Design of structures with tension components; with UK National Annex to BS EN 1993-1-11:2006.

**BS EN 1993-1-12:2007**

Eurocode 3: Design of steel structures – Part 1.12: Additional rules for the extension of EN 1993 up to steel grades S 700; with UK National Annex to BS EN 1993-1-12:2007.

**BS EN 1993-5: Piling:2007**

Eurocode 3: Design of steel structures – Part 5: Piling; with UK National Annex to BS EN 1993-5:2007.

**BS EN 1993-6:2007**

Eurocode 3: Design of steel structures – Part 6: Crane supporting structures; with UK National Annex to BS EN 1993-6:2007.

**BS EN 1994-1-1:2004**

Eurocode 4: Design of composite steel and concrete structures – Part 1.1: General rules and rules for buildings; with UK National Annex to BS EN 1994-1-1:2004.

**BS EN 1995-1-1:2004+A1:2008**

Eurocode 5: Design of timber structures – Part 1.1: General – Common rules and rules for buildings; with UK National Annex to BS EN 1995-1-4+A1:2008.

**BS EN 1996-1-1:2005**

Eurocode 6: Design of masonry structures – Part 1.1: General rules for reinforced and unreinforced masonry structures; with UK National Annex to BS EN 1996-1-1:2005.

**BS EN 1996-2:2006**

Eurocode 6: Design of masonry structures – Part 2: Design considerations, selection of materials and execution of masonry; with UK National Annex to BS EN 1996-2:2006.

**BS EN 1996-3:2006**

Eurocode 6: Design of masonry structures – Part 3: Simplified calculation methods for unreinforced masonry structures; with UK National Annex to BS EN 1996-3:2006.

**BS EN 1997-1:2004**

Eurocode 7: Geotechnical design – Part 1: General rules; with UK National Annex to BS EN 1997-1:2004.

**BS EN 1997-2:2007**

Eurocode 7: Geotechnical design – Part 2: Ground investigation and testing; with UK National Annex to BS EN 1997-2:2007.

**BS EN 1998-1:2004**

Eurocode 8: Design of structures for earthquake resistance – Part 1: General rules, seismic actions and rules for buildings; with UK National Annex to BS EN 1998-1:2004.

**BS EN 1998-5:2004**

Eurocode 8: Design of structures for earthquake resistance – Part 5. Foundations, retaining structures and geotechnical aspects; with UK National Annex to BS EN 1998-2:2004.

**BS EN 1999-1-1:2007+A1:2009**

Eurocode 9: Design of aluminium structures – Part 1.1: General structural rules; with UK National Annex to BS EN 1999-1-1:2007+A1:2009.

**BS EN 1999-1-3:2007+A1:2011**

Eurocode 9: Design of aluminium structures – Part 1.3: Structures susceptible to fatigue; with UK National Annex to BS EN 1999-1-3:2007.

**BS EN 1999-1-4:2007+A1:2011**

Eurocode 9: Design of aluminium structures – Part 1.4: Cold-formed structural sheeting; with UK National Annex to BS EN 1999-1-4:2007.

**BS EN 1999-1-5:2007**

Eurocode 9: Design of aluminium structures – Part 1.5: Shell structures; with UK National Annex to BS EN 1999-1-5:2007.

**BS EN 12620:2002**

Aggregates for concrete. AMD 15333 2004.

**BS EN 13670:2009**

Execution of concrete structures.

**BSI PD 6687-1:2010**

Published Document – Background paper to the UK National Annexes to BS EN 1992-1 and BS EN 1992-3.

**BSI PD 6687-2:2008**

Published Document – Recommendations for the design of structures to BS EN 1992-2:2005.

**BSI PD 6688-1-1:2011**

Published Document – Recommendations for the design of structures to BS EN 1991-1-1.

**BSI PD 6688-1-4:2009**

Published Document – Background information the National Annex to BS EN 1991-1-4 and additional guidance.

**BSI PD 6688-1-7:2009**

Published Document – Recommendations for the design of structures to BS EN 1991-1-7.

**BSI PD 6693-1-1:2012**

Published Document – Recommendations for the design of timber structures to BS EN 1995-1-1 (to be published by BSI in 2012).

**BSI PD 6695-1-9:2008**

Published Document – Recommendations for the design of structures to BS EN 1993-1-9.

**BSI PD 6695-1-10:2009**

Published Document – Recommendations for the design of structures to BS EN 1993-1-10.

**BSI PD 6697:2010**

Published Document – Recommendations for the design of masonry structures to BS EN 1991-1-1 and BS EN 1996-2.

**BSI PD 6698:2009**

Published Document – Recommendations for the design of structures for earthquake resistance to BS EN 1998.

**BSI PD 6702-1:2009**

Published Document – Structural use of aluminium – Part 1. Recommendations for the design of aluminium structures to BS EN 1999.

**BSI PD 6705-3:2009**

Published Document – Structural use of steel and aluminium – Part 3. Recommendations for the execution of aluminium structures to BS EN 1090-3.

**A3****BS EN 1990:2002+A1:2005**

Eurocode – Basis of structural design; with UK National Annex to BS EN 1990:2002+A1:2005.

**BS EN 1991-1-7:2006**

Eurocode 1: Actions on structures – Part 1.7: General actions – Accidental actions; with UK National Annex to BS EN 1991-1-7:2006.

**BS EN 1992-1-1:2004**

Eurocode 2: Design of concrete structures – Part 1.1: General rules and rules for buildings; with UK National Annex to BS EN 1992-1-1:2004.

**BS EN 1993-1-1:2005**

Eurocode 3: Design of steel structures – Part 1.1: General rules and rules for buildings; with UK National Annex to BS EN 1993-1-1:2005.

**BS EN 1994-1-1:2004**

Eurocode 4: Design of composite steel and concrete structures – Part 1.1: General rules and rules for buildings; with UK National Annex to BS EN 1994-1-1:2004.

**BS EN 1995-1-1:2004+A1:2008**

Eurocode 5: Design of timber structures – Part 1.1: General – Common rules and rules for buildings; with UK National Annex to BS EN 1995-1-4+A1:2008.

**BS EN 1996-1-1:2005**

Eurocode 6: Design of masonry structures – Part 1.1: General rules for reinforced and unreinforced masonry structures; with UK National Annex to BS EN 1996-1-1:2005.

**BS EN 1999-1-1:2007+A1:2009**

Eurocode 9: Design of aluminium structures – Part 1.1: General structural rules; with UK National Annex to BS EN 1999-1-1:2007+A1:2009.

# Annex F

*DRAFT*

---

STATUTORY INSTRUMENTS

---

**2012 No.**

**BUILDING AND BUILDINGS, ENGLAND**

**The Building (Repeal of Provisions of Local Acts) Regulations  
2012**

*Made* - - - - - \*\*\*  
*Laid before Parliament* \*\*\*  
*Coming into force* - - - - - \*\*\*

The Secretary of State makes the following Regulations in exercise of the powers conferred by sections 1(1) of, and paragraphs 10 and 11(1)(c) of Schedule 1 to, the Building Act 1984<sup>(11)</sup>, having consulted, in accordance with section 14(4) of that Act<sup>(12)</sup>, the Building Regulations Advisory Committee, such persons or bodies as appear to him to be representative of local authorities and such other bodies as appear to him to be representative of the interests concerned, and being satisfied that certain provisions of local Acts are unnecessary in consequence of building regulations:

**Citation, commencement and application**

1.—1. These Regulations may be cited as the Building (Repeal of Provisions of Local Acts) Regulations 2012 and shall come into force on [ ] 2012.

(1) These Regulations apply in relation to England only.

**Repeal of certain provisions of local Acts**

2. The following local Acts are repealed to the extent specified in the third column.

<i>Act</i>	<i>Citation</i>	<i>Extent of repeal</i>
London Building Acts (Amendment) Act 1939	1939 c. xcvii	Sections 20 and 21; in section 148(2), remove number (ix) in the table of offences; in section 151(3) and (4) omit “or in section 20 (Precautions against fire in certain buildings and cubical extent of buildings) or section 21 (Uniting of buildings)”.

---

<sup>(11)</sup> 1984 c. 55. Paragraph 11(1)(c) of Schedule 1 was inserted by the Deregulation and Contracting Out Act 1994 (c. 40), section 32(1). The majority of functions exercised by the Secretary of State under the 1984 Act, so far as exercisable in relation to Wales, were transferred to the Welsh Ministers by The Welsh Ministers (Transfer of Functions) (No.2) Order 2009 (SI 2009/3019), article 2, made under the Government of Wales Act 2006 (c.32), section 58.

<sup>(12)</sup> Section 14(4) was inserted by the Deregulation and Contracting Act 1994, section 32(2).

County of Merseyside Act 1980	1980 c. x	Sections 50, 52 and 53; in section 132(2) omit “In section 50 (Parking places: safety requirements), subsection (6); in section 52 (Fire precautions in high buildings), subsection (5); in section 53 (Fire precautions in large storage buildings), subsection (6);”; in section 139(2) omit “Section 53 (Fire precautions in large storage buildings);”; section 140.
West Midlands County Council Act 1980	1980 c. xi	Section 44; in section 112(2) omit “In section 44 (Parking places: safety requirements), subsection (6);”; in section 117(2) omit “Section 44 (Parking places: safety requirements);”.
Cheshire County Council Act 1980	1980 c. xiii	Sections 48 and 55; in section 103(2) omit “in section 48 (Parking places: safety requirements), subsection (6); in section 55 (Further precautions against fire in high buildings), subsection (4);”; in section 110(2) omit “Section 48 (Parking places: safety requirements);”.
Isle of Wight Act 1980	1980 c. xv	Section 30; in section 58(2) omit “In section 30 (Parking places: safety requirements), subsection (6);”; in section 64(2) omit “Section 30 (Parking places: safety requirements);”.
South Yorkshire Act 1980	1980 c. xxxvii	Sections 53 and 57; in section 100(2) omit “In section 53 (Parking places: safety requirements), subsection (6);”.
Greater Manchester Act 1981	1981 c. ix	Sections 61, 64 and 65; in section 172(2) omit “In section 61 (Parking places: safety requirements), subsection (6); in section 64 (Fire precautions in high buildings), subsection (5); in section 65 (Fire precautions in large storage buildings), subsection (6);”; in section 181(2) omit “Section 65 (Fire safety precautions in large storage buildings), so far as it relates to conditions with respect to the matters specified in subsection (3)(d) of that section;”.
County of Kent Act 1981	1981 c. xviii	Section 51; in section 123(2) omit “In section 51 (Parking places: safety requirements), subsection (6);”; in section 129(2) omit “Section 51 (Parking places: safety requirements);”.
Derbyshire Act 1981	1981 c. xxxiv	Section 28; in section 57(2) omit “In section 28 (Parking places: safety requirements), subsection (6);”; in section 63(2) omit “Section 28 (Parking places: safety requirements);”.
Humberside Act 1982	1982 c. iii	Sections 12 and 88; in section 95(2) omit “Section 12 (Parking places: safety

		requirements);”
County of Avon Act 1982	1982 c. iv	Sections 7 and 51; in section 58(2) omit “Section 7 (Parking places: safety requirements);”; in section 59(2) omit “Section 7 (Parking places: safety requirements);”.
Cumbria Act 1982	1982 c. xv	Section 23; in section 59(2) omit “In section 23 (Parking places: safety requirements), subsections (6) and (9);”; in section 63(2) omit “Section 23 (Parking places: safety requirements);”; in section 64(2) omit “Section 23 (Parking places: safety requirements);”.
Hampshire Act 1983	1983 c. v	Sections 11, 13 and 76; in section 82(2) omit “Section 11 (Parking places: safety requirements); Section 13 (Fire precautions in certain large buildings);”; in section 84(2) omit “Section 13 (Fire precautions in certain large buildings);”.
Staffordshire Act 1983	1983 c. xviii	Section 25; in section 66(2) omit “In section 25 (Parking places: safety requirements), subsection (6);”; in section 71(2) omit “section 25 (Parking places: safety requirements);”.
County of Lancashire Act 1984	1984 c. xxi	Section 34.
Surrey Act 1985	1985 c. iii	Sections 18, 19, 27 and section 33(2).
Bournemouth Borough Council Act 1985	1985 c. v	Sections 16, 17, 18 and 60; in section 68(2) omit “Section 17 (Fire precautions in certain large buildings); Section 18 (Fire precautions in high buildings);”.
Leicestershire Act 1985	1985 c. xvii	Sections 49, 52 and 53; in section 98(2) omit “In section 49 (Parking places: safety requirements), subsection (6); In section 52 (Fire precautions in high buildings), subsection (5); In section 53 (Fire precautions in large storage buildings), subsection (6).”; in section 109(3) omit “Section 52 (Fire precautions in high buildings); Section 53 (Fire precautions in large storage buildings).”.
Hereford City Council Act 1985	1985 c. xlii	Sections 17 and 36; in section 42(2) omit “Section 17 (Parking places: safety requirements).”.
Worcester City Council Act 1985	1985 c. xliii	Sections 46 and 56; in section 61(2) omit “Section 46 (Parking places: safety requirements).”.
Poole Borough Council Act 1986	1986 c. i	Sections 10, 14 and 15; in section 32(2) omit “In section 10 (Parking places: safety requirements), subsection (5); In section 14 (Fire precautions in certain large buildings), subsection (6); In

		section 15 (Fire precautions in high buildings), subsection (5).”; in section 39(2) omit “Section 14 (Fire precautions in certain large buildings); Section 15 (Fire precautions in high buildings).”.
Berkshire Act 1986	1986 c. ii	Sections 36, 37 and 38; in section 67(2) omit “In section 36 (Parking places: safety requirements), subsection (5); In section 37 (Fire precautions in large storage buildings), subsection (6); In section 38 (Fire precautions in high buildings), subsection (5); in section 75(2) omit “Section 37 (Fire precautions in large storage buildings); Section 38 (Fire precautions in high buildings).”.
County of Cleveland Act 1987	1987 c. ix	Section 6.

### Existing conditions

3. Any condition imposed under a provision repealed by regulation 2 before [the day on which these Regulations come into force] shall cease to have effect from that day, and no proceedings or other action may be begun or continued to enforce such condition or conditions on or after that day.

Signed by authority of the Secretary of State

Address  
Date

*Name*  
[Parliamentary Under Secretary of State]  
Department for Communities and Local Government



### **EXPLANATORY NOTE**

*(This note is not part of the Regulations)*

These Regulations repeal certain provisions in local Acts in England relating to fire precautions in car parks, large storage buildings and high buildings, as set out in regulation 2. The provisions impose conditions beyond those required by building regulations and are unnecessary as a result of Part B of Schedule 1 to the Building Regulations 2010 (S.I. 2010/2214) which provides for the safety and welfare of persons in and around buildings.

Regulation 3 provides that at the date of repeal any existing conditions imposed under a provision repealed by regulation 2 will cease to have effect. An impact assessment has been prepared in relation to these Regulations, and is obtainable from [the Department for Communities and Local Government website].

# Annex G

## Proposed amendments to Approved Document C

page 9

### **FLOOD RISK**

Delete the first sentence of paragraph 0.8 and replace with:

**“0.8** Policies set out in the [draft] National Planning Policy Framework aim to avoid inappropriate development in areas at risk of flooding.”

Delete footnote reference 7 on pages 9 and 44 and replace with:

<sup>7</sup>[Draft] National Planning Policy Framework.

page 10

Delete footnote references 8 to 10 and replace 8 with:

<sup>8</sup> *Improving the flood performance of new buildings – Flood resilient construction*, Communities and Local Government, Defra and the Environment Agency (May 2007)

pages 12, 16 and 41

### **SECTION 1**

Delete footnote references 14 and 36 on pages 12, 16 and 41 and replace with:

<sup>14, 36</sup> BS EN 1997-2:2007: Eurocode 7: *Geotechnical design – Part 2: Ground investigation and testing* and UK National Annex to BS EN 1997-2:2007.

Delete footnote reference 21 on pages 12 and 41 and replace with:

<sup>21</sup> BS 8103-1:2011 *Structural design of low-rise buildings – Part 1: Code of Practice for stability, site investigation, precast concrete floors and ground floor slabs for housing*

Delete footnote reference 37 on pages 16 and 41 and replace with:

<sup>37</sup> BS 10175:2011 *Code of practice for investigation of potentially contaminated sites*.

page 21

## **RADON**

*Delete paragraph 2.40 and replace with:*

**“2.40** Guidance on whether an area is susceptible to radon, and appropriate protective measures for domestic properties, can be obtained from BRE Report BR 211<sup>75</sup>. The maps in BR 211 are based on the indicative atlas published by the Health Protection Agency and the British Geological Survey.

BR211 provides guidance on the different radon protective measures appropriate in areas where more than three percent of homes and areas where more than 10% of homes are predicted to have radon at or above the Radon Action Level.

BR 211 also provides guidance on radon risk reports which may be used as an alternative approach to the maps it provides for assessing the need for protective measures. These reports are available from:

- UK Radon, [www.UKradon.org](http://www.UKradon.org) , for extensions to dwellings.
- BGS Georeports, [www.shop.bgs.ac.uk/Georeports](http://www.shop.bgs.ac.uk/Georeports) , for other development sites.
- The Health Protection Agency, [radon@hpa.org.uk](mailto:radon@hpa.org.uk) , for large workplaces.

A European Council Directive establishes a common basis for radiation protection legislation in all Member States. The Ionising Radiations Regulations<sup>76</sup> set a national reference level for radon gas and employers and self-employed persons responsible for a workplace are required to measure radon levels on being directed to do so. See also the HSE/BRE guide ‘Radon in the workplace’<sup>77</sup>.

The Health and Safety Executive provides guidance on protection from radon in the workplace ([www.hse.gov.uk/radiation/ionising/radon.htm](http://www.hse.gov.uk/radiation/ionising/radon.htm)). Additionally techniques for installing radon resistant membranes described in BR 211 may be suitable for use in domestic sized buildings with heating and ventilation regimes similar to those used in dwellings but this should be done with caution. Information in ‘Radon in the workplace’ provides guidance for existing non-domestic buildings.”

*Delete paragraph 2.41.*

*Delete footnote references 75 and 81 on pages 21, 24 and 43 and replace with:*

“<sup>75,81</sup> BRE Report BR 211 Radon: guidance on protective measures for new buildings. 2007 edition.”

*Delete footnote reference 77 on pages 21 and 43 and replace with:*

*“<sup>77</sup>Radon in the workplace, A guide for building owners and managers, 2011, ISBN 978-1-84806-177-4”*

*Delete footnote reference 78*

*pages 28, 38, 40 and 43*

***Resistance to condensation***

*Delete footnote references 99, 131 and 144 on pages 28, 38, 40 and 43 and replace with:*

*“<sup>99, 131, 144</sup> Accredited Construction Details which can be downloaded from [www.planningportal.gov.uk/buildingregulations/approveddocuments/part1/bcassociateddocuments9/acd](http://www.planningportal.gov.uk/buildingregulations/approveddocuments/part1/bcassociateddocuments9/acd)”*

*Pages 47 and 48*

***Annex A: Guidance on the assessment of land affected by contaminants***

Delete.

# Annex H

## Proposed amendments to Approved Document M

Page 7

### Use of guidance

*Delete all existing text under and including the heading “DISABILITY DISCRIMINATION ACT 1995 AND THE DISABILITY DISCRIMINATION (EMPLOYMENT) ACT 1996” and insert the following:*

“The Equality Act 2010 and the Disability Regulations 2010

The Equality Act 2010 brings together existing equalities legislation, including the Disability Discrimination Act 1995 (DDA), with the aim of harmonising existing provisions into a single streamlined framework of equalities legislation to deliver better outcomes for the protected groups listed.

The Equality Act (<http://www.legislation.gov.uk/ukpga/2010/15/contents>) states that reasonable adjustments to a building or its facilities must be made in relation to accessibility and this duty is set out in paragraph 2 of both Schedule 2 (in relation to public authorities and service providers); Schedule 8 (in relation to employers) and Schedule 15 (in relation to associations) of the Equality Act.

Although the guidance in this Approved Document (AD M), if followed, tends to demonstrate compliance with Part M of the Building Regulations, this does not necessarily equate to compliance with the obligations and duties set out in the Equality Act 2010. This is because service providers and employers are required by the Equality Act to consider any feature which might put a person belonging to the identified equality groups at a substantial disadvantage. In some instances this will include designing features or making adjustments to features which are outside the scope of AD M. It remains for the persons undertaking building work to consider if further provision, beyond that described in AD M, is advisable.

10 Year Exemption for associations and service providers

An exemption from the duty to make reasonable adjustment, as set out above, is provided in Regulation 9 (Reasonableness and design standards) of and the Schedule to the Equality Act 2010 (Disability) Regulations 2010;

<http://www.legislation.gov.uk/uksi/2010/2128/regulation/9/made>

This schedule prescribes that it is not reasonable for a provider of services, a public authority carrying out its functions, or an association to have to remove or alter a physical feature which has been provided to assist access to the building or its facilities and which accords with the relevant objectives, design considerations and provisions in the edition of Approved Document M applicable at the time the building work was carried out.

Applicants should be aware that this is not a blanket exemption from duties under the Equality Act, and relates only to the duty to make reasonable adjustment to physical features built in strict accordance with the guidance provided in AD M. As with all other types of building work, service providers will still need to consider the needs of disabled people which are outside the scope of AD M. It is for applicants, not building control bodies to consider how these obligations are to be met.

(Please note that the exemption for employers was revoked by The Disability Discrimination (Employment Field) (Leasehold Premises) Regulations 2004 as set out in the 2004 edition of Approved Document M)."

Page 9

## Notes

### Stairs and ramps

*Delete: 'Protection from falling, collision and impact'*

*Delete: 'The guidance in AD M reflects more recent ergonomic research conducted to support BS 8300 (see below) and should take precedence over guidance in AD K where it may appear to conflict.'*

*Insert: After 'Approved Document K*

*Protection from falling, collision and impact and glazing safety'*

### Manifestation on glazed doors and glazed screens:

*Delete: 'Approved Document N – 'Glazing – safety in relation . . . . . until Part N and AD N are revised.'*

*Insert:*

*'Approved Document K, Section 7 contains guidance on manifestation.'*

Page 14

## **Section 0: General guidance**

### **Access statements**

#### **0.20**

*Delete 'Access statements' and existing 0.20 text and insert the following:*

**'Access strategy' '0.20** It is important that applicants clearly communicate to the building control body how their chosen approach to meeting the accessibility needs of the likely end users of a building and its facilities demonstrates compliance with the requirements of Part M of the Building Regulations. The guidance in this Approved Document is designed to indicate only one way in which those requirements may be met, and it is relatively common that alternative, equally satisfactory ways of meeting the requirements can be adopted depending on the size, scale, nature and intended use of the building.'

Page 15

### **Access statements**

#### **0.21**

*Delete existing 0.21 text and insert the following:*

**'0.21** Where alternative solutions are proposed, the onus remains with the applicant to demonstrate that those solutions are appropriate and meet the requirements, for example by showing that it is equivalent to the provisions set out in this Approved Document. This should include the use of appropriate research evidence or reference to recognised British (or other) Standards as necessary to support the chosen approach. It is advisable to ensure that the appropriate level of provision is agreed with the building control body prior to commencing building work, as retrospective alterations can be costly and disruptive'.

#### **0.22**

*Delete existing 0.22 text insert the following:*

**'0.22** Applicants should therefore seek to engage with Building Control bodies at the earliest possible stage to identify key issues and risks, and to discuss the best way to demonstrate the access strategy for the building work taking place. To avoid unnecessary administrative burden, communication should focus on areas where proposals diverge from the guidance in this Approved Document rather than providing an exhaustive explanation where features comply'.

**0.23**

*Delete existing 0.23 text and insert the following:*

**0.23** Provision of a written Access Statement is not required to accompany a Building Control application though it may be useful in some circumstances. The key focus should be on ensuring that applicants and Building Control Bodies are agreed as to the appropriate level of provision in the completed building work’.

**0.24**

*Delete existing 0.24 text and insert the following:*

**0.24** In smaller or simpler works this could be achieved by having a conversation to review the proposals and recording the outcome of discussions by correspondence. In large, complex works or where there are significant constraints imposed by an existing site, this might involve a written statement setting out key aspects of the access approach, supported by annotated drawings as well as face to face meetings to resolve key issues. It is for the Building Control body and applicant to agree which, if any of these proposed approaches should be used on a case by case basis to ensure that the functional requirements of Part M of the Building Regulations are satisfied’.

*Page 16*

**Access statements****0.25**

*Delete existing 0.21 text and insert the following:*

**0.25** It should be noted that approval of proposed works by a Building Control body does not by necessity indicate compliance with duties under the Equalities Act 2010. Applicants need to consider these wider equality obligations when undertaking building work and whether provision in some circumstances should exceed that set out within this Approved Document. The relationship between Part M of the Building Regulations and the Equality Act is set out on page 7 of this Approved Document’.

*Page 16*

**Definitions****0.29**

*Insert: After the definition for ‘Dwelling’*

**‘Easy access**, for use by a broad range of users and used on a day to day basis for primary circulation between different levels.’



Page 25

## Section 1: Access to buildings other than dwellings

### Hazards on access route

#### Provisions

##### 1.39

Delete: Colon after 'Requirements M1 or M2 will be satisfied if'. Paragraphs a. and b. Diagram 8.

Insert: After 'Requirements M1 or M2 will be satisfied if'

'Approved Document K, Section 8 is complied with.'

Page 25

## Section 2: Access into buildings other than dwellings

### Doors to accessible entrances

#### Provisions

##### 2.13c

Delete: Paragraph c. Diagram 9.

Insert:

'c. in accordance with Approved Document K, Section 10.'

New Diagram 9 as below:

**Diagram 9** Effective clear width of doors

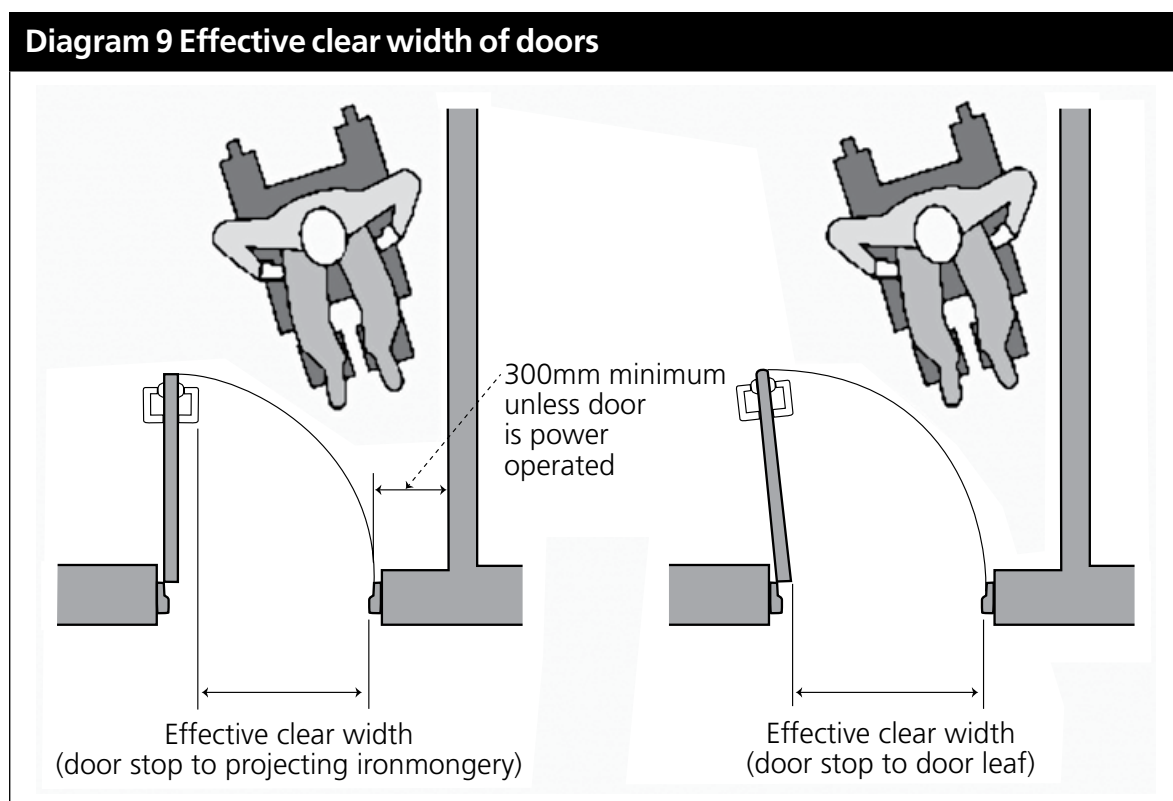

Page 30

## **Glass entrance doors and glazed screens**

### **Provisions**

#### **2.24**

*Delete: Colon after 'Glass entrance doors and glazed screens will satisfy Requirement M1 or M2 if' Paragraphs a–d.*

*Insert: After 'Glass entrance doors and glazed screens will satisfy Requirement M1 or M2 if'*

*'in accordance with Approved Document K, Section 7.'*

Page 41

## **Section 3: Horizontal and vertical circulation in buildings other than dwellings**

### **Internal stairs**

#### **Provisions**

#### **3.51**

*Delete: 'Internal stairs will satisfy Requirement M1 or M2 if:' Paragraphs a–e. Diagram 12. Last paragraph 'Note: For school buildings, in respect of 3.51(c) and (d), the rise should not exceed 170mm with a preferred going of 260mm. Also for schools, refuges should be provided for all stairs where no other arrangement is in place (see AD B, B1 xvi, and BS 5588-8 for details of refuges).'*

*Insert:*

*'Easy access stairs will satisfy Requirement M1 or M2 if they are in accordance with Approved Document K, Section 1.'*

Page 41

### **Internal ramps**

#### **Provisions**

#### **3.53**

*Delete: Colon after 'Internal ramps will satisfy Requirement M1 or M2 if' Paragraphs a–e.*

*Insert: After 'Internal ramps will satisfy Requirement M1 or M2 if'*

*'they are in accordance with Approved Document K, Section 2.'*

Page 41

## **Handrails to internal steps, stairs and ramps**

### **Provisions**

#### **3.55**

*Delete: 'all the provisions contained in 1.37'.*

*Insert: After 'Handrails to internal steps, stairs and ramps will satisfy Requirement M1 or M2 if they comply with'*

*'Approved Document K, Sections 1–3'.*

Page 68

## **Section 7: Circulation within the entrance storey of the dwelling**

### **Vertical circulation within the entrance storey**

#### **Provisions**

#### **7.7**

*Delete: Colon after 'A stair providing vertical circulation within the entrance storey of the dwelling will satisfy Requirement M1 if' Paragraphs a–c.*

*Insert: After 'A stair providing vertical circulation within the entrance storey of the dwelling will satisfy Requirement M1 if'*

*'it is in accordance with Approved Document K, Section 1'.*

Page 70

## **Section 9: Passenger lifts and common stairs in blocks of flats**

### **Common stairs**

#### **9.5**

*Delete: After 'Requirement M1 will be satisfied if a building containing flats, in which a passenger lift is not to be installed, is provided with a suitable stair' delete 'which has:'. Paragraphs a–f. Diagram 30.*

*Insert: After 'Requirement M1 will be satisfied if a building containing flats, in which a passenger lift is not to be installed, is provided with a suitable stair'*

*'in accordance with Approved Document K, Section 1.'*

Note: the use of an easy access stair in this situation would be the most suitable means of access.

# Annex I

## Draft Approved Document to support Regulation 7 (Materials and workmanship)

### Contents

<b>Use of guidance</b>	<b>2</b>
The Approved Documents	2
<b>Materials and Workmanship The Requirement: Regulation 7</b>	<b>4</b>
<b>Guidance</b>	<b>5</b>
Performance	5
<b>Section 1: Materials</b>	<b>6</b>
Ways of establishing the fitness of materials	6
Short-lived materials	9
Materials susceptible to changes in their properties	10
Resistance to moisture	10
Resistance to substances in the subsoil	10
<b>Section 2: Workmanship</b>	<b>11</b>
Ways of establishing the adequacy of workmanship	11
a. Standards	11
b. Technical approvals	11
c. Management systems	11
d. Past experience	11
e. Tests	12
<b>Appendix A: <del>Abbreviations and glossary</del> <u>Other Approved Documents</u></b>	
<b><u>Appendix B: Further information</u></b>	<b>13</b>
<b>Appendix <del>B</del><u>C</u>: Standards referred to in this document</b>	<b>17</b>
<b>DIAGRAM</b>	
1. CE marking	8

## Use of guidance

### THE APPROVED DOCUMENTS

The Building Regulations ~~2000~~ **2010** (SI 2010/2214), ~~which~~ came into operation on 1 October 2010, to replace the Building Regulations 2000 (SI ~~2000~~**2531**) and consolidate them including all subsequent revisions to those regulations. This document is one of a series that has been approved and issued by the Secretary of State for the purpose of providing practical guidance with respect to the requirements of Schedule 1 to and Regulation 7 of the Building Regulations 2010 for England and Wales.

~~At the back of this document is a list of all the documents that have been approved and issued by the Secretary of State for this purpose.~~

Approved Documents are intended to provide guidance for some of the more common building situations and, under the Building Act 1984 section 7(1)(b), proof of compliance with such a document may be relied on as tending to negative liability for alleged contravention of a requirement of the Building Regulations. However, there may well be alternative ways of achieving compliance with the requirements. **Thus there is no obligation to adopt any particular solution contained in an Approved Document if you prefer to meet the relevant requirement in some other way.**

#### Other requirements

The guidance contained in an Approved Document relates only to the particular requirements of the Regulations which the document addresses. The building work will also have to comply with the ~~R~~ requirements of any other relevant paragraphs in Parts of Schedule 1 to the Regulations.

There are Approved Documents which give guidance on each of the Parts of Schedule 1 some of which also give guidance on the application of Regulation 7 in respect of the requirement of the particular Part. Appendix A lists amendments to the text in these Approved Documents. In all case where the Construction Products Directive 1988 is referenced, this should be read as a reference to the Construction Products Regulation 2011.

#### Technical specifications

Building Regulations are made for specific purposes, primarily the health and safety, ~~energy conservation and the welfare and convenience of disabled people,~~ and for energy conservation. Standards and ~~other~~ technical approvals are specifications may provide relevant guidance to the extent that they relate to these considerations. However, they may also address other aspects of performance such as serviceability, or aspects which although they relate to health and safety are not covered by the Regulations.



When an Approved Document makes reference to a named standard, the ~~relevant~~ version of the standard **to which it refers** is the one listed at the end of the publication. However, if this version has been revised or updated by the issuing standards body, the new version may be used as a source of guidance provided it continues to address the relevant requirements of the Regulations.

~~The appropriate use of a product which complies with a European Technical Approval as defined in the Construction Products Directive will meet the relevant requirements.~~

~~The Department intends to issue periodic amendments to its Approved Documents to reflect emerging harmonised European Standards. Where a national standard is to be replaced by a harmonised European Standard, there will be a co-existence period during which either standard may be referred to. At the end of the co-existence period the national standard will be withdrawn.~~



## The Requirement

This Approved Document deals with Regulation 7 of the Building Regulations 2010.

<i>Requirement</i>	<i>Limits on application</i>
<b>Materials and workmanship</b>	
7. Building work shall be carried out -	
(a) with adequate and proper materials which -	
(i) are appropriate for the circumstances in which they	
are used,	
(ii) are adequately mixed or prepared, and	
(iii) are applied, used or fixed so as adequately to perform the functions for which they are	
designed; and	
(b) in a workmanlike manner.	

~~Note: Attention is drawn to the requirements of Regulation 8 (Limitation on requirements) of the Building Regulations 2010:~~

~~'8. Parts A to K and N of Schedule 1 to these regulations shall not require anything to be done except for the purpose of securing reasonable standards of health and safety for persons in or about buildings (and any others who may be affected by buildings or matters connected with buildings).'~~



## Guidance

### Performance

- 0.1** In the Secretary of State's view the requirements of Regulation 7 will be met where **materials** are:
- of a suitable nature and quality in relation to the purposes and conditions of their use; and the **workmanship** is such that
  - where relevant, materials are adequately mixed or prepared; and
  - applied, used or fixed so as to perform adequately the functions for which they are intended.

**Materials** include **both manufactured** products, **such as** components, fittings, **items of equipment and systems, as well as** naturally occurring materials, e.g. **such as** stone, timber and thatch, **items of equipment** and backfilling for excavations in connection with building work.

### ~~0.2 Environmental impact of building work~~

~~The environmental impact of building work can be minimised by careful choice of materials, and where appropriate the use of recycled and recyclable materials should be considered. The use of such materials must not have any adverse implications for the health and safety standards of the building work.~~

### 0.32 Limitations

**Regulation 7 applies across all Parts of the Building Regulations.**

**However, in accordance with Regulation 8, for Parts A to D, F to K, N and NP (except for paragraphs G2, H2 and J7) of Schedule 1, the**

**standards of materials and workmanship need be no more than are necessary to secure reasonable standards of health or safety for persons in or about the building.**

For Parts L and M of Schedule 1, the standards of materials and workmanship need be no more than are necessary to conserve fuel and power and to provide access and facilities for disabled people respectively. **For Part E of Schedule 1, the standards of materials and workmanship need be no more than are necessary to secure reasonable resistance to the passage of sound for the welfare and convenience of persons in or about the building.**

### 0.43 Continuing control

There are no provisions under the Building Regulations for continuing control over the use of materials following the completion of building work. It should be noted that Section 19 of the Building Act 1984 enables local authorities to impose conditions with regard to prescribed materials where it is proposed to



# 1

## Materials

construct a building of short-lived materials, notwithstanding that the plans conform with the Regulations. However, this section has no effect at present, as no materials are currently prescribed for its purpose.

## Section 1: Materials

### 1.1 Schedule 1 to the Building Regulations 2010 sets out the requirements that building works must comply with in broad functional terms.

Approved Documents contain references to materials or products covered by European harmonised product standards, British Standards, by certificates issued by European Technical Approvals issuing bodies, or by and other technical specifications. ~~but~~ **However, as there is no obligation to adopt any particular solution contained in an Approved Document in order to meet functional requirements**, the references are not exclusive and other materials or products may be suitable in the particular circumstances.

#### Ways of establishing the fitness of materials

1.2 There are a number of ways in which the suitability of a material for use for a specific purpose may be assessed. The following are aids which may be used for establishing this:

##### a. CE marking

###### CE marking under the Construction Products Regulation

Many construction products and materials will be CE marked. By law<sup>1</sup> this will be the case if the product is on the EU market and:

- it is covered by a harmonised European product standard<sup>2</sup>, or
- it is covered by a European Technical Assessment<sup>3</sup>. These are used by manufacturers of products which are not covered by a harmonised standard, but who still wish their products to be CE marked.

The CE marking will show (among other information) the reference of the product standard and levels or classes of performance being declared against some or all of the characteristics covered by the standard. The CE marking will be on the product, its label, the packaging or accompanying documents. In addition, the product will have a Declaration of Performance containing more detailed information on the product. This may be a paper or electronic document, or it may be on a website.

In the absence of indications to the contrary, the building control body should assume that the information in the declaration and CE marking is accurate and reliable, and that the product meets the declared performances. Provided that the declared performances correspond to

1 Regulation (EU) No 305/2011 laying down harmonised conditions for the marketing of construction products and repealing Council Directive 89/106/EEC <http://eur-lex.europa.eu/LexUriServ/LexUriServ.do?uri=OJ:L:2011:088:0005:0043:EN:PDF>

2 A list of the harmonised product standards under the Construction Products Regulation can be found at <http://ec.europa.eu/enterprise/newapproach/nando/index.cfm?fuseaction=cpd.hs> For further information see under CEN at Appendix B.

3 For further information see under EOTA at Appendix B.

## 1

## Materials

**the requirements for the intended use, the building control body should not prohibit or impede the use of the product.**

**CE marking under other EU Directives and Regulations**

**Products may also be CE marked under other European legislation, such as the Gas Appliances Directive (2009/142/EC) or the Pressure Equipment Directive (97/23/EC). Under these Directives, the CE marking is a declaration that the product meets the essential requirements set out in the relevant legislation which are preconditions for those products to be placed on the EU market – for example, minimum safety requirements.**

**Some products will have CE marking in accordance with both the Construction Products Regulation and other legislation. Where this is the case, the CE marking demonstrates compliance with all the requirements in the relevant EU legislation.**

**ab. British Standards**

**New British Standards can be developed and published for products not covered by European standards. Where a construction product has been made and assessed in accordance with one or more British Standards, this may be another way of establishing that the product is suitable for its intended use.** The material conforms to the relevant provisions of an appropriate British Standard.

**Note:** ~~However,~~ **nearly all construction product British Standards for construction products have now been** will be revised to become the British 'transposition' **version** of the new **harmonised** European Standards presently being drafted. Traditionally, where an EN has been transposed and has replaced a British Standard on more or less the same material (but possibly a radically changed technical content), it has taken the previous number. The BSI numbering policy ~~now~~ is to adopt the CEN<sup>4</sup> numbering, prefaced with BS **e.g. BS EN 197-1: 2000**. Again, each title may contain different characteristics and requirements from the superseded British Standard.

British Standards are normally withdrawn when their equivalent European Standards are published but, under certain circumstances, arrangements may be made for a deferred withdrawal of the British Standard.

Because it is impossible to change everything simultaneously, **During the process of European harmonisation of standards** there ~~will be~~ **is** a period **(usually one year)** during which the old British Standards ~~will have to~~ co-exist with the new **harmonised version**. Some will be **The old British standards are then** 'withdrawn' **by BSI** but remain available **for use, for example** for **construction** work which has already commenced; ~~some will be retained as~~

4 Comité Européen de Normalisation – see Appendix B for further information

'obsolescent' where, for example, they are called up in Approved Documents not yet revised; some will co-exist for some years, fully maintained alongside the new transposed European-originated standards (as with some of the structural codes).

Detailed enquiry will have to be made as to applicability in each context. Where the old standard retains applicability, it may reasonably be presumed that relevant products comply with Regulation 7. Where there is a new standard, it may again be necessary to check applicability during the transitional period, following which compliance may reasonably also be presumed.

The European-originated standards will have specifically identified clauses, those which relate to the 'harmonised' requirements containing the (largely health and safety) requirements relevant to the Building Regulations, and 'non-harmonised' requirements containing additional matters relating to trading requirements of concern to the construction industry, but not to Regulation 7. The reference in this Approved Document only applies to the 'harmonised' requirements.

#### **b.c. Other national and international technical specifications**

The material conforms to the national technical specifications of other Member States which are contracting parties to the European Economic Area, as long as such specifications provide in use at least an equivalent level of performance to the relevant British Standard **countries may also be the basis for demonstrating that products can meet the performance requirements of the Building Regulations**. Where necessary, it is up to the person intending to carry out the work to provide translations and to demonstrate equivalence. It should be noted that the **national** technical specifications of other **EU Member States (and non-EU countries that are full members of CEN)** will, for the same reason, be in a process of change paralleling that of **are being progressively replaced by harmonised European standards, as is the case with** British Standards.

#### **c. Technical approvals**

The material is covered by a national or European certificate issued by a European Technical Approvals issuing body, and the conditions of use are in accordance with the terms of the certificate. Where necessary it is up to the person intending to carry out the work to provide translations and to demonstrate equivalence.

#### **d. CE marking**

The material has CE marking (see Diagram 1). The CE marking gives a presumption of conformity with the stated minimum legal requirements when placed on the market as set out in the Construction Products Regulations 1991. These requirements include compliance with a harmonised European Standard as formally announced in the Official Journal of the European

## 1

## Materials

Communities (or with part of a European Standard) or with a European Technical Approval, coupled with the appropriate attestation procedure.

If used appropriately and in satisfactory conditions, a product bearing CE marking shall be presumed by the building control body to satisfy the relevant requirements unless there are reasonable grounds for suspecting otherwise. In this context relevant requirements are defined in relation to the essential requirements of the Construction Products Directive, and are:

- mechanical resistance and stability;
- safety in case of fire;
- hygiene, health and the environment;
- safety in use;
- protection against noise;
- energy economy and heat retention.

Depending on the intended use of the product and the particular regulatory requirements all, or some, of the essential requirements may be relevant.

A CE marked material can only be rejected if either its performance does not, in fact, conform to the particular technical specification against which the CE marking has been claimed or, in the case of a declared value or a class of performance, the resultant value does not meet the relevant requirements of the Building Regulations. If the building control body has reasonable grounds for suspecting that a CE marked material does not conform to the specification against which CE marking has been claimed, he would have to prove this. In such circumstances he should notify the relevant Trading Standards Officer. This will enable the UK Government, where necessary, to notify the Commission.

It should be noted that not all materials will necessarily be CE marked under the Construction Products Directive, and it will not, in any case, be possible for all products to be CE marked until all relevant technical specifications have become available. However, there are some products where CE marking is compulsory under other Directives (e.g. gas boilers, which should fully comply with all relevant Directives and should be installed in accordance with the appliance manufacturer's instructions).

Diagram 1 CE marking



#### ed. Independent certification schemes

There are many ~~UK~~ **independent** product certification schemes **in the UK and elsewhere which may be a further source of information on product performance**. Such schemes certify compliance with the requirements of a recognised document which is appropriate to the purpose for which the material is to be used. Materials which are not so certified may still conform to a relevant standard.

~~Many~~ **For the most part,** certification bodies which ~~approve~~ **run** such schemes are accredited by **the UK Accreditation Service (UKAS) and those certification bodies in other European States where the national accreditation body belongs to the European co-operation on Accreditation (EA) may be similarly accredited and provide a means of ensuring that such certifications can be relied on<sup>5</sup>**. However, it is **important to check the scope of the accreditation of certification bodies as accreditation may cover only part of the certification body's testing or certification business**. If a product has been tested and certified as complying with a British Standard by an approved body in another Member State of the European Community, in accordance with the special procedure under Article 16 of the Construction Products Directive, then, if it is used appropriately and in satisfactory conditions, it should normally be accepted by the building control body as complying with that standard. If it is not so accepted then the onus of proof in such a case is on the building control body, who must notify the Trading Standards Officer. This will enable the UK Government, where necessary, to notify the Commission.

#### fe. Tests and calculations

~~It can be shown by~~ Tests, by calculation or by other means may be used to demonstrate that the material will be capable of performing the function for which it is intended. The Accreditation Scheme for Testing Laboratories run by UKAS together with similar schemes run by equivalent ~~certification bodies~~ **national accreditation bodies belonging to the European co-operation on Accreditation (EA)**, including accreditation schemes operated by other ~~Member~~ **European** States of the EU and recognised by that State's government, **may be similarly accredited and** provide a means of ensuring that such tests can be relied on.

<sup>5</sup> See Appendix B for further information.

# 1 Materials

## gf. Past experience

The material can be shown by Past experience, such as in a building in use, to ~~be~~ **may show that the material is** capable of performing the function for which it is intended.

## hg. Sampling

~~Under regulation 46 of the Building Regulations 2010~~ Local authorities have the power to take samples of materials to be used in building work. ~~Regulation 17 allows the local authority (but not approved inspectors) to take such samples as they consider necessary to establish compliance~~ **whether such materials comply** with the provisions of the Regulations.

~~Approved inspectors may wish to consider entering into arrangements with their clients that will allow sampling of materials where they, the approved inspector, consider it to be necessary.~~

It should be noted that Regulation ~~17~~**46** does not apply to any work that has been specified in an initial notice or to any work for which a final certificate has been given by an approved inspector and accepted by the local authority.

**However, Regulation 8 of the Building (Approved Inspectors etc.) Regulations 2010 provides that an approved inspector, having given an initial notice which continues to be in force, may take samples of material as are reasonable to enable him/her to be satisfied within the limits of professional skill and care that Regulation 7 of the Building Regulations or any of the other applicable Regulations are complied with.**

## Short-lived materials

- 1.3 Some materials, in the absence of special care, may be considered unsuitable because of their rapid deterioration in relation to the expected life of the building. It is not possible to set down any specific criteria from which the length of life of a material can be considered against the requirements of the Regulations.
- 1.4 A short-lived material which is readily accessible for inspection, maintenance and replacement may meet the requirements of the Regulations provided that the consequences of failure are not likely to be serious to the health or safety of persons in and around the building.
- 1.5 Where a short-lived material is not readily accessible for inspection and maintenance or replacement and the consequences of failure are likely to be serious for health or safety, it is most unlikely that the material will be suitable.
- 1.6 ~~It should be~~ **As** noted ~~in paragraph 0.4 above,~~ that Section 19 of the Building Act 1984 enables local authorities **have the power** to impose conditions with regard to prescribed materials where it is proposed to construct a building of

~~short-lived materials, notwithstanding that the plans conform with the Regulations. However, this section has no effect at present, as no materials are currently prescribed for its purpose.~~

### **Materials susceptible to changes in their properties**

- 1.7** Some materials may undergo changes to their properties when they are exposed to certain environmental conditions which may affect their performance over time.

~~Some examples are concrete made with cements containing a high proportion of calcium aluminates (HAC), certain stainless steels, structural silicone sealants, and intumescent paints for enhancing fire resistance of building elements.~~

**Such materials can be used in works where these changes do not adversely affect their performance.** They will meet the requirements of the Regulations provided that their final residual properties, including their structural properties, can be estimated at the time of their incorporation in the work. It should also be shown that these residual properties will be adequate for the building to perform the function for which it is intended for the expected life of the building.

### **Resistance to moisture**

- ~~**1.8** Any material which is likely to be adversely affected by condensation, by moisture from the ground or by rain or snow will meet the requirements if:~~
- ~~a. the construction will resist the passage of moisture to the material; or~~
  - ~~b. the material is treated or otherwise protected from moisture.~~

### **Resistance to substances in the subsoil**

- ~~**1.9** Any material in contact with the ground or in the foundations will meet the requirements if it is capable of resisting attacks by deleterious material in the subsoil such as sulphates (see Section 2 of Approved Document C: Site preparation and resistance to moisture).~~



## Section 2: Workmanship

### Ways of establishing the adequacy of workmanship

**2.1** It may be useful to consider the following aids for establishing the adequacy of workmanship:

**a. Standards**

- i. The method of carrying out the work is included in the recommendations of a British Standard Code of Practice. Note that **the BS 8000 series of standards on Workmanship on building sites** gathers together guidance from other BSI Codes and Standards (**see Appendix C**). Or
- ii. The method conforms to an equivalent technical specification which may include a national technical specification of other Member States which are contracting parties to the European Economic Area.

**b. Technical approvals**

The workmanship is specified for a material covered by a national or European certificate issued by a ~~European Technical Approvals issuing body,~~ **member of EOTA** and the conditions of use are in accordance with the terms of the certificate.

Alternatively the workmanship may be covered by an equivalent technical approval (~~including a technical approval of any other member of the European Organisation for Technical Approvals, EOTA~~), which provides an equivalent level of performance, and the conditions of use are in accordance with the terms of the technical approval. It is up to the person who intends to carry out the work to show that the method of workmanship will provide the equivalent level of protection and performance.

**c. Management systems**

The workmanship is covered by a scheme which complies with the relevant recommendations of BS EN ISO 9000 Quality management systems, and related **series of standards (see Appendix C)**. There are a number of such UKAS accredited schemes. These schemes relate to products and processes for which there may also be a suitable British or other technical standard.

There are also independent schemes for accreditation and registration of installers of materials, products and services that provide a means of ensuring that work has been carried out by knowledgeable contractors to appropriate standards.

**d. Past experience**

It can be shown by **Past** experience, such as in a building in use, **may show** that the method of workmanship is capable of performing the function for which it is intended.

**e. Tests**

The local authority has the power to test sewers and drains in or in connection with buildings. Regulation 16 allows the local authority (but not an approved inspector) to make such tests as they consider necessary to establish compliance with the requirements of Part H of Schedule 1 to the Regulations.

Approved inspectors may wish to consider entering into arrangements with their clients that will allow testing of drains where they, the approved inspector, consider it to be necessary.

The requirements of Part H of Schedule 1 to the Regulations cover:

- i. — foul water drainage;
- ii. — cesspools, septic tanks and settlement tanks; and
- iii. — rainwater drainage.

The Approved Document for Part H (Drainage and waste disposal) contains guidance on testing drainage installations.

It should be noted that Regulation 16 does not apply to any work that has been specified in an initial notice or to any work for which a final certificate has been given by an approved inspector and accepted by the local authority.

**In three instances the Building Regulations require those carrying out building works to have testing carried out for the purpose of demonstrating compliance with the requirements of the regulations:**

- **Sound insulation testing of dwelling-houses, flats and rooms for residential purposes to demonstrate compliance with Part E of Schedule 1 (regulation 41);**
- **Mechanical ventilation air flow rate testing to demonstrate the compliance of new dwellings with Part F1(1) of Schedule 1 (regulation 42); and**
- **Pressure testing of new buildings to demonstrate compliance with Part L1(a)(i) of Schedule 1 (regulation 43).**

**Building control bodies also have powers to make such tests and take such samples of materials as they consider necessary to establish whether work and materials comply with the requirements of regulations 4 and 7 of the Building Regulations 2010.**

**In addition, those carrying out building works may voluntarily include testing in the activities they carry out for the purpose of demonstrating compliance of those works with the requirements of the Regulations.**



## Appendix A:

### Other Approved Documents

**The following sections in other Approved Documents should be replaced by the text below.**

**'Materials and workmanship**

**Any building work which is subject to the requirements imposed by Schedule 1 to the Building Regulations should be carried out in accordance with Regulation 7. Guidance on meeting these requirements on materials and workmanship is contained in the Approved Document to Regulation 7.**

**Building Regulations are made for specific purposes, primarily the health and safety, welfare and convenience of people and for energy conservation. Standards and other technical specifications may provide relevant guidance to the extent that they relate to these considerations. However, they may also address other aspects of performance such as serviceability, or aspects which although they relate to health and safety are not covered by the Regulations.**

**When an Approved Document makes reference to a named standard, the relevant version of the standard to which it refers is the one listed at the end of the publication. However, if this version has been revised or updated by the issuing standards body, the new version may be used as a source of guidance provided it continues to address the relevant requirements of the Regulations.'**

Approved Document	Edition	Page	All text under the following headings is replaced
B (V1)	2006	4-5	Materials and Workmanship Independent Certification Schemes Technical Specifications
		6	The Construction Products Directive Designation of Standards Commission Guidance Papers and Decisions, Guidance Paper G, Guidance Paper J
B (V2)	2006	5-6	Materials and Workmanship Independent Certification Schemes Technical Specifications
		7-8	The Construction Products Directive Designation of Standards Commission Guidance Papers and Decisions, Guidance Paper G, Guidance Paper J
D	1992/02	1	Materials and Workmanship



Approved Document	Edition	Page	All text under the following headings is replaced
			Independent Certification Schemes Technical Specifications
<b>E</b>	2003	6-7	Materials and Workmanship Independent Certification Schemes Technical Specifications
<b>F</b>	2010	11-12	Materials and Workmanship Independent Certification Schemes Technical Specifications
<b>G</b>	2010	10-11	Materials and Workmanship Technical Specifications Independent schemes of Certification and Accreditation
<b>H</b>	2002	4-5	Materials and Workmanship Independent Certification Schemes Technical Specifications
<b>J</b>	2010	7	Materials and Workmanship Technical Specifications Independent schemes of Certification and Accreditation
<b>M</b>	2004	5-6	Materials and Workmanship Independent Certification Schemes Technical Specifications
<b>P</b>	2006	3-4	Materials and Workmanship Independent Certification Schemes Technical Specifications

## Appendix AB: Abbreviations and glossary Further information

### **British Board of Agrément (BBA)**

PO Box 195

Bucknalls Lane, Garston, Watford WD2 7NG

Tel: 01923 665300

Fax: 01923 665304

E-mail: [bba@btinternet.com](mailto:bba@btinternet.com)

Website: [www.bbacerts.co.uk](http://www.bbacerts.co.uk)

See European Technical Approval issuing body.

**Comité Européen de Normalisation (CEN)** is the European standards body recognised by the Commission to prepare harmonised **European product** standards to support the Construction Products Regulation. ~~The members comprise the standards bodies of participating members of the EU, of EFTA (European Free Trade Association).~~ **CEN's National Members are the National Standards Organisations of the 27 European Union countries and Croatia plus three countries of the European Free Trade Association (Iceland, Norway and Switzerland).**

**For construction products, harmonised European product standards are produced by CEN (or CENELEC the European committee for electrotechnical standardisation) under mandate from the Commission, with the requirement to cover all relevant performance requirements where Member States have regulations on those products relating to the basic requirements for construction works (set out in Annex I of the Construction Products Regulation 2011). Declarations of Performance against such standards are expected to provide sufficient information for any Member State to allow the product onto their market and for specifiers/users to be able to assess whether the product is suitable for its intended use.**

**Non-harmonised European standards include, for example, supporting test or calculation standards or standards for products or services that have not been mandated under a CE Marking Directive. They do not provide for the affixing of the CE marking, but may be referenced in harmonised European product standards.**

**An overview of European standards for construction products is available at:**

**<http://www.cen.eu/cen/Sectors/Sectors/Construction/Pages/default.aspx>**



**EOTA comprises the Approval Bodies which issue European Technical Approvals under the Construction Products Directive 1988 (up to July 2013) and the Technical Assessment Bodies issuing European Technical Assessments under the Construction Products Regulation 2011 (from July 2013). Further information is available at: [www.eota.eu](http://www.eota.eu)**

**British Standards (BSs)**

British Standards are issued by the British Standards Institution (**BSI**) issues **British Standards**. To achieve British Standard status the draft document is submitted for public consultation and all comment received, considered and consensus reached.

**BSI**

British Standards Institution  
389 Chiswick High Road, London W4 4AL  
Tel: 020 8996 9001  
Fax: 020 8996 7001  
E-mail: [info@bsi.org.uk](mailto:info@bsi.org.uk)  
Website: [www.bsi.org.uk](http://www.bsi.org.uk)

**Building control body**

This term is used to include both local authority building control and approved inspectors.

**CE marking**

The CE marking is more fully described in Annex III 'Attestation of conformity with technical specifications' of the Construction Products Directive. The marking may be on the product, a label, the packaging or accompanying commercial documentation. It will be accompanied by a reference to the technical specification to which it conforms, and, where appropriate, by indications to identify the characteristics of the product.

**Construction Products Directive (CPD)**

The Council Directive reference 89/106/EEC dated 21 December 1988 and published in the Official Journal of the European Communities No. L40/12 dated 11.2.89. The CE Marking Directive (93/68/EEC) amends the CPD.

**Construction Products Regulations**

The Construction Products Regulations 1991 (SI 1991/1620) came into force on 27 December 1991 and implement the Construction Products Directive.



The CE Marking Directive came into force on 1 January 1995, and was implemented in the UK by the Construction Products (Amendment) Regulations 1994 (SI 1994/3051).

#### **European Economic Area (EEA)**

The European Economic Area consists of those states which signed the Agreement at Oporto on 2 May 1992 together with the Protocol adjusting that Agreement signed at Brussels on 17 March 1993. The states are Austria, Belgium, Denmark, Finland, France, Germany, Greece, Iceland, Ireland, Italy, Luxembourg, Liechtenstein, Netherlands, Norway, Portugal, Spain, Sweden, United Kingdom.

#### **EOTA**

European Organisation for Technical Approvals is the umbrella organisation for bodies issuing European Technical Approvals for individual products. It operates over the same area as CEN. EOTA complements the work of CEN in that the guidelines it produces are for products for which standards do not exist as yet, possibly due to the innovative nature of the product.

General Secretary based in Brussels

Tel: 0032 2 502 6900

Fax: 0032 2 502 3814

E-mail: eota@gle.be

#### **European Commission**

The executive organisation of the EU, based in Brussels. It ensures implementation and observance of Community rules, has the sole power to propose legislation based on the Treaties and executes the decisions taken by the Council of Ministers.

#### **EN**

European standards are implemented as identical national standards in each of the Member States, and in the United Kingdom as BS ENs. The British Standard will include additional guidance about its relationship with other standards in the family and possibly about the use of the standard. An EN does not have a separate existence as a formally published document.

#### **European Technical Approval**

A favourable technical assessment of the fitness for use of a construction product for an intended use, issued for the purposes of the Construction Products Directive by a body authorised by a Member State to issue European Technical Approvals for those purposes and notified by that Member State to the European Commission.

#### **European Technical Approval issuing body**





A body notified under Article 10 of the Construction Products Directive. The details of these institutions are published in the 'C' series of the Official Journal of the European Communities.

At the present time the listing for the United Kingdom is the British Board of Agrément and WIMLAS Ltd. An up to date listing can be found on the Building Regulations pages of the ODPM website [www.odpm.gov.uk](http://www.odpm.gov.uk).

#### **EU**

The 15 countries of the European Union, namely Austria, Belgium, Denmark, Finland, France, Germany, Greece, Ireland, Italy, Luxembourg, Netherlands, Portugal, Spain, Sweden, United Kingdom.

#### **ISO**

**International Organisation for Standardisation (ISO) is** ~~the worldwide standards organisation, some of whose standards may be adapted for use with the Construction Products Directive~~ **federation of national standards institutions, promoting the development of standardisation of goods and services.** Standards are identified by 'ISO' and a number. These may be transposed into the UK as BS ISO, or adopted as European standards and implemented as BS EN ISO. ISO standards are separately published standards (unlike ~~ENs~~ **European standards**). **For further information see: [www.iso.org](http://www.iso.org)**

#### **Technical specification**

A standard or a European Technical Approval Guide. It is the document against which compliance can be shown in the case of a standard and against which an assessment is made to deliver the European Technical Approval.

#### **UKAS**

**United Kingdom Accreditation Service (UKAS) is the sole national accreditation body recognised by government to assess, against internationally agreed standards, organisations that provide certification, testing, inspection and calibration services. Accreditation by UKAS demonstrates the competence, impartiality and performance capability of these evaluators.**

#### **United Kingdom Accreditation Service**

21–47 High Street

Feltham, Middlesex TW3 4UN

Tel: 020 8917 8400

Fax: 020 8917 8500

**[www.ukas.com](http://www.ukas.com)**



**The European co-operation on Accreditation (EA) is the umbrella organisation for all National Accreditation Bodies in Europe. As these bodies have bilateral agreements indicating equivalence with UKAS, it can be said that product certification bodies, inspection bodies and test laboratories approved by them are equivalent to those approved by UKAS. For further information see:**  
[www.european-accreditation.org/content/mla/scopes](http://www.european-accreditation.org/content/mla/scopes)

**New Approach Notified and Designated Organisations (NANDO) is an information system produced by the European Commission which lists all the bodies which have been notified by individual countries or states to carry out conformity assessment tasks on harmonised technical specifications:**  
<http://ec.europa.eu/enterprise/newapproach/nando>

**Standard**

A BS EN, etc.

**WIMLAS**

WIMLAS Limited

St Peter's House, 6-8 High Street, Iver

Buckinghamshire SL0 9NG

Tel: 01753 737744

Fax: 01753 792324

E-mail: [wimlas@compuserve.com](mailto:wimlas@compuserve.com)

See European Technical Approval issuing body.

## Appendix BC: Standards referred to in this document

~~**BS EN ISO 9000:2000**~~

~~Quality management and systems. Fundamentals and vocabulary.~~

~~(Withdrawn and superseded by~~

**BS EN ISO 9000:2005**

Quality management systems. Fundamentals and vocabulary.)

~~**BS EN ISO 9001:1994**~~

~~Quality systems. Model for quality assurance in design, development, production, installation and servicing.~~

~~(Withdrawn and superseded by BS EN ISO 9001:2000 Quality management systems. Requirements.)~~

**BS EN ISO 9001:2008**

**Quality management systems. Requirements.**

~~**BS EN ISO 9002:1994**~~

~~Quality systems. Model for quality assurance in production, installation and servicing.~~

~~(Withdrawn and superseded by BS EN ISO 9001:2000 Quality management systems. Requirements.)~~

**BS 8000-1:1989**

Workmanship on building sites. Code of practice for excavation and filling.

**BS 8000-2-1:1990**

Workmanship on building sites. Code of practice for concrete work. Mixing and transporting concrete. AMD 9324 1997.

**BS 8000-2-2:1990**

Workmanship on building sites. Code of practice for concrete work. Sitework with in situ and precast concrete.

~~**BS 8000-3:1989**~~

~~Workmanship on building sites. Code of practice for masonry. AMD 6195 1990.~~

~~(Withdrawn and superseded by~~

**BS 8000-3:2001**

Workmanship on building sites. Code of practice for masonry.)

**BS 8000-4:1989**

Workmanship on building sites. Code of practice for waterproofing.

**BS 8000-5:1990**

Workmanship on building sites. Code of practice for carpentry, joinery and general fixings.

**BS 8000-6:1990**

Workmanship on building sites. Code of practice for slating and tiling of roofs and claddings.

**BS 8000-7:1990**

Workmanship on building sites. Code of practice for glazing.

**BS 8000-8:1994**

Workmanship on building sites. Code of practice for plasterboard partitions and dry linings.

~~**BS 8000-9:1989**~~

~~Workmanship on building sites. Code of practice for cement/sand floor screeds and concrete floor toppings.~~

~~(Withdrawn and superseded by~~

**BS 8000-9:2003**

Workmanship on building sites. Cementitious levelling screeds and wearing screeds. Code of practice.)

~~**BS 8000-10:1995**~~

~~Workmanship on building sites. Code of practice for plastering and rendering. AMD 9271 1996.~~

~~**BS 8000-11:1989**~~

~~Workmanship on building sites. Code of practice for wall and floor tiling.~~

~~**BS 8000-11-1:1989**~~

~~Workmanship on building sites. Code of practice for wall and floor tiling. Ceramic tiles, Terrazzo tiles and mosaics (confirmed 1995).~~

~~**BS 8000-11-2:1990**~~

~~Workmanship on building sites. Code of practice for wall and floor tiling. Natural stone tiles. AMD 8623 1995.~~

**BS 8000-11:2011**



**Workmanship on building sites – Internal and external wall and floor tiling. Ceramic and agglomerated stone tiles, natural stone and terrazzo tiles and slabs, and mosaics. Code of practice.**

**BS 8000-12:1989**

Workmanship on building sites. Code of practice for decorative wallcoverings and painting.

**BS 8000-13:1989**

Workmanship on building sites. Code of practice for above ground drainage and sanitary appliances.

**BS 8000-14:1989**

Workmanship on building sites. Code of practice for below ground drainage.

**BS 8000-15:1990**

Workmanship on building sites. Code of practice for hot and cold water services (domestic scale).

**BS 8000-16:1997+A1:2010**

Workmanship on building sites. Code of practice for sealing joints in buildings using sealants.

# Annex J

## **2012 consultation on changes to the Building Regulations in England**

### **Section one consultation questions response form**

We are seeking your views on the following questions on the Government's proposed changes to the Building Regulations and the building control system.

If possible, please could you respond by email to:

[building.regulations@communities.gsi.gov.uk](mailto:building.regulations@communities.gsi.gov.uk)

Alternatively, responses can be sent by post to:

Building Regulations Consultation  
Building Regulations and Standards Division  
Department for Communities and Local Government  
Zones 5/G9  
Eland House  
Bressenden Place  
London SW1E 5DU

## About you:

(i) **Your details**

Name:	
Position:	
Name of organisation (if applicable):	
Address:	
Email Address:	
Telephone number:	

(ii) **Are the views expressed on this consultation an official response from the organisation you represent or your own personal views?**

Organisational response  Personal views

(iii) **Are your views expressed on this consultation in connection with your membership or support of any group? If yes please state name of group:**

Yes  No

Name of group:

(iv) Please tick the *one* box which best describes you or your organisation:

<p><b>Builders/Developers:</b></p> <p>Builder – Main contractor <input type="checkbox"/></p> <p>Builder – Small builder (extensions/repairs/maintenance, etc) <input type="checkbox"/></p> <p>Installer/specialist sub-contractor <input type="checkbox"/></p> <p>Commercial developer <input type="checkbox"/></p> <p>House builder <input type="checkbox"/></p>	<p><b>Property Management:</b></p> <p>Housing association (registered social landlord) <input type="checkbox"/></p> <p>Residential landlord, private sector <input type="checkbox"/></p> <p>Commercial <input type="checkbox"/></p> <p>Public sector <input type="checkbox"/></p>
<p><b>Building Occupier:</b></p> <p>Homeowner <input type="checkbox"/></p> <p>Tenant (residential) <input type="checkbox"/></p> <p>Commercial Building <input type="checkbox"/></p>	<p><b>Building Control Bodies:</b></p> <p>Local authority building control <input type="checkbox"/></p> <p>Approved Inspector <input type="checkbox"/></p>
<p><b>Designers/Engineers/Surveyors:</b></p> <p>Architect <input type="checkbox"/></p> <p>Civil/structural engineer <input type="checkbox"/></p> <p>Building services engineer <input type="checkbox"/></p> <p>Surveyor <input type="checkbox"/></p>	<p><b>Specific Interest:</b></p> <p>Competent person scheme operator <input type="checkbox"/></p> <p>National representative or trade body <input type="checkbox"/></p> <p>Professional body or institution <input type="checkbox"/></p> <p>Research/academic organisation <input type="checkbox"/></p>
<p><b>Manufacturer/supply chain</b> <input type="checkbox"/></p>	<p><b>Energy Sector</b> <input type="checkbox"/></p> <p><b>Fire and Rescue Authority</b> <input type="checkbox"/></p> <p><b>Other</b> (please specify) <input type="checkbox"/></p> <div style="border: 1px solid black; height: 20px; width: 100%; margin-top: 5px;"></div>



(v) **Please tick the one box which best describes the size of your or your organisation’s business?**

- Micro – typically 0 to 9 full-time or equivalent employees (incl. sole traders)
- Small – typically 10 to 49 full-time or equivalent employees
- Medium – typically 50 to 249 full-time or equivalent employees
- Large – typically 250+ full-time or equivalent employees
- None of the above (please specify)

(vi) **Are you or your organisation a member of a competent person scheme?**

Yes  No

Name of scheme:

(vii) **Would you be happy for us to contact you again in relation to this consultation?**

Yes  No

DCLG will process any personal information that you provide us with in accordance with the data protection principles in the Data Protection Act 1998. In particular, we shall protect all responses containing personal information by means of all appropriate technical security measures and ensure that they are only accessible to those with an operational need to see them. You should, however, be aware that as a public body, the Department is subject to the requirements of the Freedom of Information Act 2000, and may receive requests for all responses to this consultation. If such requests are received we shall take all steps to anonymise responses that we disclose, by stripping them of the specifically personal data – name and e-mail address – you supply in responding to this consultation. If, however, you consider that any of the responses that you provide to this survey would be likely to identify you irrespective of the removal of your overt personal data, then we should be grateful if you would indicate that, and the likely reasons, in your response, for example in the comments box.

# Questions

## Chapter 1: Introduction

1.1 Do you have any views as to the applicability of the micro business moratorium to these proposals?

Comment

1.2 Should the timing of regulatory changes and/or transitional arrangements be changed to minimise the impact on business and, if so, how should this be done?

Yes  No

Comment

1.3 Consultees are welcome to provide information on any of the points raised in Chapter one of this document. They can also take this opportunity to submit ideas and evidence that they would like us to take into account as we consider future approaches to the Building Regulations.

Comment

## Chapter 2: Amendments to Part A

2.1 Do you agree that the structural design standards currently referenced in Approved document A should be replaced by the Eurocodes-based British Standards with their National Annexes as proposed? Please explain why if you do not.

Yes  No

Comment

2.2 It is generally accepted that use of the Eurocodes-based British Standards with their National Annexes and non-conflicting complementary information provides at least an equivalent level of safety and serviceability to the withdrawn British Standards currently referenced. Do you have evidence that this is not the case?

Yes  No

Comment

2.3 We believe that our approach in Annex E to referencing BSi Published Documents provides essential and helpful additional information in support of Eurocodes implementation. Do you agree (and if not which, if any, are essential to include)?

Yes  No

Comment

2.4 Do you agree that additional guidance should be provided in a Circular, or similar, to clarify how currently referenced and withdrawn British Standards might continue to be used up to and beyond 2015?

Yes  No

Comment

2.5 Do you agree that the actual cost of constructing buildings using standards based on Eurocodes are neutral overall and what evidence do you have to support or refute this?

Yes  No

Comment

2.6 Do you agree with the estimated transitional costs? If not, please identify which assumptions/estimates you disagree with and, if possible, provide evidence to support your response.

Yes  No

Comment

2.7 Do you have any further information to support or refute the assessment of the benefits associated with referencing the Eurocodes-based British Standards in Approved Document A?

Yes  No

Comment

2.8 Do you agree that the changes proposed to Diagram 6 and the calculation procedure in Diagram 7 provide equivalent safety to the current guidance?

Yes  No

Comment

2.9 Do you agree the new optional procedure for determining Factor O given in Diagram 6, Figure 3 provides equivalent safety and economy of design?

Yes  No

Comment

2.10 The changes proposed to Section 5 guidance, particularly in referencing Eurocodes-based British standards for structural design, are intended to provide an equivalent level of safety and robustness to the current approach based upon withdrawn British standards. Do you agree?

Yes  No

Comment

2.11 Do you agree that changing the area limit in Diagram 24 from 70m<sup>2</sup> to 100m<sup>2</sup> to align guidance with BS EN 1991-1-7 "General actions- Accidental actions" introduces no significant additional risks?

Yes  No

Comment

2.12 Do you agree that it is helpful to include reference to the ISE Practical Guide to Structural Robustness and Disproportionate Collapse in Buildings as an Alternative approach reference?

Yes  No

Comment

2.13 Do you agree it would be a helpful change in line with industry practice to amend the guidance in Approved Document A (2E4) to a three-tier graduated approach for minimum foundation depths in clay soils?

Yes  No

Comment

2.14 Are you able to provide information to inform further consideration of any of the topics raised in or related to this consultation chapter, for example, in relation to freestanding walls or to loading increase and decrease associated with re-covering of roofs?

Yes  No

Comment

## Chapter 3: Amendments to Part B

3.1 Do you agree that the proposed amendments to Table 10 are reasonable and maintain the necessary standards of safety?

Yes  No

Comment

3.2 Do you agree that the proposed amendments to Table 11 are reasonable and maintain necessary standards of safety?

Yes  No

Comment

3.3 Do you think the proposed new Diagram 28 is necessary to illustrate the changes to Table 11?

Yes  No

Comment

3.4 Are you able to provide information to inform further consideration of any of the topics raised in or related to this consultation chapter?

Yes  No

Comment

## Chapter 4: Amendments to Part C

4.1 Do you have any evidence that would be helpful when we refine our analysis, including the working assumptions in the Impact Assessment, post consultation?

Yes  No

Comment

4.2 Would removing Annex A of Approved Document C cause problems?

Yes  No

Comment

4.3 Do you have any other suggestions for change that you believe we should consider in our future review work?

Yes  No

Comment



## Chapter 5: Consolidation of Parts K, M and N

5.1 Are there any changes to the technical provisions in the proposed draft Approved Document K which would impact on the way in which industry applies the existing guidance? If so, can you identify specifically what has changed and what that impact would be.

Yes  No

Comment

5.2 Do you have any further suggestions for areas of consolidation/rationalisation between guidance relating to Parts K, M and N?

Comment

5.3 Do you think that style and layout of the Approved Document makes it easier to read and use?

Yes  No

Comment

5.4 Are there any changes in the words used in the proposed draft Approved Document K which will impact on the way industry would apply the guidance? If so, can you identify specifically what has changed and what that impact would be.

Yes  No

Comment

5.5 Do you agree with the estimated transitional costs? If not, please identify which assumptions you disagree with and provide evidence to support alternative values.

Yes  No

Comment

5.6 Do you agree with the estimated benefits for the rationalisation/consolidation? If not, please identify which assumptions you disagree with and provide evidence to support alternative values.

Yes  No

Comment

5.7 Are you able to provide information to inform further consideration of any of the topics raised in or related to this consultation chapter?

Yes  No

Comment

## Chapter 6: Amendments to Guidance on Access Statements in Part M

6.1 Do you agree that the proposed alternative approaches to written Access Statements can be effective in helping to communicate compliance?

Yes  No

Comment

6.2 Does this revised wording clarify the relationship between Approved Document M and the Equality Act 2010? If not please suggest how this could be made clearer.

Yes  No

Comment

6.3 Table 3 on page 9 of the Impact Assessment sets out the percentage of building control applications currently accompanied by an Access Statement, banded by project size. Does this seem reasonable or do you have evidence to substantiate alternative figures?

Yes  No

Comment

- 6.4 Table 5 on page 10 of the Impact Assessment sets out as transitional costs the time and cost to industry in becoming familiar with revised guidance within Approved Document M and developing revised approaches to communicating compliance. Does this seem reasonable or do you have evidence to substantiate alternative figures?

Yes  No

Comment

- 6.5 Table 6, 7 and 8 on pages 12 and 13 of the Impact Assessment sets out the extent to which revised guidance will deliver efficiencies to industry and seeks to evaluate the benefits this will bring. Do you agree with our estimate of time, and cost which will be saved by a more focused risk-based approach to demonstrating compliance? If not, please suggest what values should be considered and provide any supporting evidence.

Yes  No

Comment

- 6.6 Table 7 on page 12 of the Impact Assessment sets out the underlying assumptions in the calculations of savings to homebuilders – do you agree with these figures? If not, please suggest what values should be considered and provide any supporting evidence.

Yes  No

Comment

6.7 Are there any costs to industry not identified within the consultation stage Impact Assessment that we should include? If so, what are they and what can be provided to substantiate such costs?

Yes  No

Comment

6.8 Are you able to provide information to inform further consideration of any of the topics raised in or related to this consultation chapter?

Yes  No

Comment

## Chapter 7: Domestic Security

7.1 Are you able to provide information to inform further consideration of any of the topics raised in or related to this consultation chapter?

Yes  No

Comment

## Chapter 8: Changing Places toilets

8.1 Should Approved Document M be amended to provide information about what is needed from a Changing Places toilet and, if so, should this be a simple reference to BS8300 or should the information be in the body of the Approved Document?

Yes  No

Comment

8.2 Would providing additional guidance of the sort proposed lead to any adverse impacts on building providers/occupiers?

Yes  No

Comment

## Chapter 9: Amendments to the Approved Document supporting Regulation 7

9.1 Are you able to provide information to inform further consideration of any of the topics raised in or related to this consultation chapter?

Yes  No

Comment

**ISBN: 978-1-4098-3317-8**

ISBN 978-1-4098-3317-8

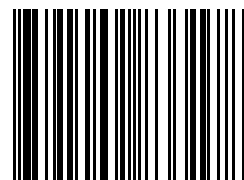

9 781409 833178