

Appendix C - Guidance on Application of Stockholm Agreement

CONTENTS

- 1 UK INTERPRETATION OF THE APPLICATION OF STOCKHOLM AGREEMENT TO HIGH-SPEED CRAFT**
- 2 GENERAL GUIDANCE NOTES ON THE STOCKHOLM AGREEMENT**
- 3 GUIDANCE NOTE ON ANNEX 1 TO THE STOCKHOLM AGREEMENT**
- 4 GUIDANCE NOTES ON THE STABILITY REQUIREMENTS CONTAINED IN ANNEX 2 TO THE STOCKHOLM AGREEMENT**
- 5 GUIDANCE NOTES ON APPENDIX TO ANNEX 2 OF THE STOCKHOLM AGREEMENT (MODEL TEST METHOD)**
- 6 GUIDANCE NOTES ON MERCHANT SHIPPING (Ro-Ro PASSENGER SHIP SURVIVABILITY) REGULATIONS 1997 (S.I. 1997 No. 647)**

1 UK Interpretation of the Application of Stockholm Agreement to High-Speed Craft

1.1 Background

The enhanced requirements for damage survivability, known as the 'Stockholm Agreement' (SA) standard, were developed primarily for application to conventional monohull vessels. However, the MCA, in common with other Marine Administrations who have signed up to the Agreement, considers it appropriate that this standard should also be applied to Ro-Ro Passenger High-Speed Craft, including multihulls. (See Regulation 6 (2) of S.I.1997 No. 647).

1.2 References

1. S.I.1997 No. 647, the Merchant Shipping (Ro-Ro Passenger Ship Survivability) Regulations 1997.
2. S.I.1996 No. 3188, the Merchant Shipping (High-Speed Craft) Regulations 1996, and any future amendment or replacement.
3. International Code of Safety for High-Speed Craft 1994, IMO Res. MSC.36(63) as amended by MSC.119(74) and MSC/Circ.1057.
4. MSN 1673 (M) Agreement Concerning Specific Stability Requirements for Ro-Ro Passenger Ships Undertaking Regular Scheduled International Voyages or to or from Designated Ports in Northwest Europe and the Baltic Sea.
5. The Stockholm Agreement (Agreement Concerning Specific Stability Requirements for Ro-Ro Passenger Ships undertaking Regular Scheduled International Voyages Between or To or From Designated Ports in Northwest Europe and the Baltic Sea) 28 February 1996.
6. International Code of Safety for High-Speed Craft 2000, IMO Res. MSC.97 (73) as amended by MSC.119(74).
7. Instructions for the Guidance of Surveyors: Passenger Ship Construction Classes I, II and IIA.
8. MIN 96 (Research Project 424: Fundamentals of Damaged Ship Survivability).
9. Code of Safety for Dynamically Supported Craft, IMO Res. A.373(X) as amended by MSC37(63) up to MSC.69(69) and MSC/Circ.1057.

1.3 General Guidance

- 1.3.1 It will be noted that according to Annex 2 of MSN1673(M), 'water on deck' calculations are to be carried out for assumed water depths depending on the residual freeboard after damage. While this represents a relatively onerous requirement for monohull vessels, the stability characteristics of multihulls are such that in most cases compliance is achieved without the need for modifications to the subdivision arrangements etc. For large vessels where the minimum residual damaged freeboard in way of the damage is 2.0m or more, the requirements of SA

are considered to be met. Further, if freeing ports on the Ro-Ro decks meet certain requirements, the calculations need not be performed (see Annex 2, para 5 of MSN1673(M)). It should be noted however that, in general, the effect of freeing ports in terms of clearing water from the deck is not considered for the purpose of the SA calculations.

- 1.3.2 Compliance with the stability requirements of the HSC Code is considered equivalent to full compliance with the 'SOLAS 90' stability standard. This implies that the A/A_{\max} value is taken as 100%, and consequently SA compliance is required by the first annual survey after 31 December 2001, or by 1 October 2002 at the latest, as defined in Reg. 6 of S.I.1997 No. 647.
- 1.3.3 In accordance with Reg. 9 of S.I.1997 No.647 a vessel to which the SA applies is required to be issued with a certificate confirming compliance. The MCA issues these documents after examination of appropriate calculations submitted by the owner/operator.
- 1.3.4 With regard to the specific stability criteria to be applied when evaluating compliance of multihull craft, or other high-speed craft, with the SA, the regulations do not provide clear instructions. However, as the HSC Code damage stability standards for multihulls were developed in recognition of the fact that the SOLAS damage standard for monohulls is not appropriate for application to multihulls, there is no justification to apply the SOLAS-based SA compliance criteria of MSN1673(M) to multihulls. Therefore, for 'water on deck calculations' of HSC the general SA requirements should be assumed - i.e. freeboard, significant wave height, height of water on deck, selection method of the worst case side damage to be tested, damage shape (model test method only) etc.; but, with the worst case **side** damage, damage length, damage shape (calculation method only) and damage stability criteria should be carried out against the appropriate issue of the HSC Code.
- 1.3.5 Experience has shown that although the model testing method is costly, it can provide for more flexible solutions for conventional Ro-Ro vessels in lieu of performing the water on deck calculations.
- 1.3.6 If it is necessary to model test a HSC vessel to meet the SA standards then the general SA requirements and methodology should be followed as far as possible. The model should be built in accordance with MSN1673(M). As with the deterministic calculation method, the worst case side damage (selected using the SOLAS standard of the minimum area under the residual stability curve up to the angle of maximum GZ) and damage length should be selected using the appropriate issue of the HSC Code. The model test should be carried out against the procedure of experiments and reviewed against the acceptance survival criteria in accordance with the test approval as dictated by MSN 1673, and where appropriate Appendix 3 of Ref. 7. (see 5 of this Appendix C). A midship damage case test may need to be carried out. It may be necessary for the shape of the damage opening to be reassessed, to the satisfaction of the attending MCA Surveyor, to allow for stepped structure or tumble home in way of the car decks, or for the practicalities of the transverse damage (in accordance with paragraph 2.6.6.2 of 1994 HSC Code and paragraph 2.6.7 of 2000 HSC Code, as appropriate) extending beyond the breadth of one hull of a multihull.

1.3.7 Although MIN 96 can be followed as an indicator of the behaviour of a damaged vessel in a seaway motion and of how to counteract any adverse behaviour (e.g. optimising cross flooding), it is at present not intended to replace the existing methods; a model test or deterministic calculations are still necessary. Paragraph 2.1.4 of 2000 HSC Code should be noted. Paragraph 2.2.3.2 of 2000 HSC Code does not exclude a vessel from the Stockholm requirements. MIN 96 describes the use of a 6 degrees of freedom computational fluid dynamics program - not with the aim of this method being a replacement for the model testing technique (or the more deterministic calculation method) of determining the effects of water on deck that is required by the SA - but as a complementary method.

2 General Guidance Notes on the Stockholm Agreement (SLF40/Inf.14 annex 1, amended for HSC)

2.1 General

2.1.1 The most dangerous problem for a ro-ro ship with an enclosed ro-ro deck is undoubtedly that posed by the effect of a build-up of significant amount of water on that deck. The principle of additional water-on-deck has been adopted to account for the risk of accumulation of water-on-deck as a result of the dynamic behaviour, in a seaway, of the vessel after sustaining side collision damage.

2.1.2 It is considered that the problem of water accumulating on deck when entering through bow, stern and side doors has been addressed by the increased standards now required with respect to strength, closing and locking systems, as well as by the new requirements relating to the position of the extension to the collision bulkhead.

2.1.3 The damage stability requirements applicable to ro-ro passenger ships in 1990 (SOLAS '90) implicitly include the effect of water entering the ro-ro deck in a sea state in the order of 1.5m Significant Wave Height. In order to enable the ship to survive in more severe sea states those requirements have been upgraded to take into account the effect of water which could accumulate on the ro-ro deck.

2.1.4 In developing the new requirements the following basic elements were taken into account:-

- .1 MSC/Circ. 153 confirms that 99% of all recorded collisions occur in sea states up to 4 m Significant Wave Height (h_s). This was therefore taken as the most severe sea state to be considered;
- .2 compliance with SOLAS '90 standard is assumed to be equivalent to survival of the damaged ship in sea states of up to 1.5 m Significant Wave Height (h_s) which according to the distribution function in MSC/Circ.153, covers 89% of all collisions. The HSC Code is considered to be an equivalent standard to the SOLAS '90 and therefore is assumed to have an A/A_{max} value of 100%;
- .3 sea states between 1.5m to 4.0m Significant Wave Height (h_s) would be covered by the additional damage stability requirements to take into account the effect of "water-on-deck"; and
- .4 because the general requirements cover all sea conditions in which according to the statistics available collisions can be expected to occur, a reduction has been

permitted in the requirement for "water-on-deck" for ships operating in geographically defined restricted areas. The Significant Wave Height (h_s) is the qualifying parameter, in association with a 90% probability that h_s is not exceeded in that area or route.

2.1.5 When considering the amount of water to be assumed as accumulating on the ro-ro deck the figure of up to 0.5m, depending on the Significant Wave Height and residual freeboard, was agreed based on consideration of the following information:

- .1 an initial Nordic proposal which suggested 0.5m for the amount of "water-on-deck";
- .2 a study by the Society of Naval Architects and Marine Engineers (SNAME) suggested that $0.5\text{m}^3/\text{m}^2$ was a reasonable level for 4.0m Significant Wave Height on a vessel with low damaged freeboard;
- .3 model tests carried out in Finland (Model Tests of a Car Ferry with Water on the Car Deck (M-304)) which indicated the volume at the Significant Wave Height of 4.0m was approximately equal to $0.75\text{m}^3/\text{m}^2$;
- .4 investigations carried out in the United Kingdom, which indicated that the corresponding amount of water would be about 10% of the ship's displacement; and
- .5 research carried out during the Joint North West European Project (Safety of Passenger Ro-Ro vessels) which related to a static pressure head relevant to a head of water above the deck or above the still water level.

2.1.6 However it was considered more appropriate to assume a variable quantity of water on deck depending not only on the residual freeboard and Significant Wave Height, but also on a variable angle of heel. With this in mind the basic assumption of up to 0.5 metres height of accumulated water corresponding to residual freeboard and Significant Wave Height was retained.

2.1.7 Research has clearly shown that the residual freeboard had a significant effect on the amount of water assumed to be accumulated on deck. The maximum residual freeboard (f_r) to be taken into account was agreed as 2.0m based on both the Institute for Marine Dynamics (Canada) (IMD) model tests and the SNAME analytical predictions which indicated that the height of water on deck goes to zero as the residual freeboard/Significant Wave Height ratio rises above 0.5. Therefore in order to assume zero accumulation, in a Significant Wave Height of 4.0m, a residual freeboard of 2.0m would be required. The residual freeboard (f_r) in this case is defined as "the minimum distance between the damaged ro-ro deck and the waterline at the location of the damage without taking into account the additional effect of sea water accumulated on the damaged ro-ro deck".

2.1.8 A requirement on damage stability for ro-ro passenger vessels taking into account additional flooding above the ro-ro deck was developed which clearly applies to existing as well as to new ships.

2.2 Scope of application of the new requirement

This damage stability requirement should, in principle, be applied to all such passenger vessels with ro-ro decks covered by the definition "special category spaces and ro-ro cargo spaces as defined in Regulation II-2/3" (of the Class 1 to IIA Passenger Ship Construction Regulations) with the proviso that spaces which have sufficient permanent openings for water freeing purposes may be exempted from the application of the requirements of "water-on-deck". Details of the requirements for freeing ports are given in the attached notes.

2.3 Bulkhead height including a standard for testing

2.3.1 The general requirement for the minimum height of bulkheads which may need to be additionally installed on the ro-ro deck shall apply to all ro-ro passenger vessels. However, the new requirements provide for the possibility for an Administration to accept lower heights for innovative designs of bulkheads, based on the results of model experiments.

2.3.2 Any transverse and longitudinal bulkheads which are fitted to enable the vessel to meet these stability regulations must be in place and secured at all times when the ship is at sea. Accesses within such bulkheads may be opened during the voyage but only for sufficient time to permit through passage for the essential working of the vessel and only at the express authority of the master.

2.4 Modifications which may be consequential to compliance with the new standard

Passenger accesses; escapes; fire extinguishing, detection and monitoring systems; car deck drainage; ventilation; cargo securing etc must comply with the same safety standards as are applicable to the vessel after the fitting of any ro-ro car deck modifications. Provision must also be provided such that any accesses in transverse or longitudinal bulkheads/barriers cannot be obstructed.

3 Guidance Note on Annex 1 to the Stockholm Agreement (SLF40/INF.14 annex 1)

The route, routes or areas concerned have been determined by the Administrations at each end of the route or all Administrations within a defined area. The defined route or area is one in which the determined Significant Wave Height would not be exceeded with a probability of more than 10% over a one year period for all year round operation.

4 Guidance Notes on the Stability Requirements Contained in Annex 2 to the Stockholm Agreement (SLF40/INF.14 annex 1, amended for HSC)

N.B. SOLAS '90 is an equivalent standard to those applied in the HSC Codes.

Preamble

Application

It should be noted that vessels which may operate solely in areas where the significant wave is less than 1.5m and which do not have to comply with the additional water-on-deck requirements (ie, comply only with HSC Code are to comply with the dates of compliance set out with the Agreement.

Stability Standard

Paragraph 1 of Annex 2 of The Agreement (Ref.5).

As a first step all ro-ro passenger vessels must comply with the HSC Code standard of residual stability. It is the application of this requirement that defines the residual freeboard f_r necessary for the calculations required in paragraph 1.1.

Paragraph 1.1 of Annex 2 of The Agreement (Ref.5).

1. This paragraph addresses the application of a hypothetical amount of water accumulated on the bulkhead (ro-ro) deck. The water is assumed to have entered the deck via a damage opening. This paragraph requires that the vessel in addition to complying with the full requirements of the appropriate HSC Code' further complies only with that part of the HSC Code .criteria contained in paragraphs 2.13 of the 2000 HSC Code and 2.3 of the 1994 HSC Code. with the defined amount of water on deck. The vessel does not, for this calculation, need to comply with any requirements for the angles of equilibrium or non-submergence of the margin line.
2. The accumulated water is added as a liquid load with one common surface inside all compartments which are assumed flooded on the car deck. The height (h_w) of water on deck is dependent on the residual freeboard (f_r) after damage, and is measured in way of the damage (**see Fig 1**). The residual freeboard f_r is the minimum distance between the damaged ro-ro deck and the final waterline (after equalisation measures if any have been taken) in way of the assumed damage after examining all possible damage scenarios in determining the compliance with HSC Code/SOLAS 90 as required in para 1 of Annex 2 to the Agreement. No account should be taken of the effect of the hypothetical volume of water assumed to have accumulated on the damaged ro-ro deck when calculating f_r .
3. If f_r is 2.0m or more, no water is assumed to accumulate on the ro-ro deck. If f_r is 0.3m or less, then height h_a is assumed to be 0.5 metres. Intermediate heights of water are obtained by linear interpolation (**see Fig 2**)

Paragraph 1.2 of Annex 2 of The Agreement (Ref.5).

Means for drainage of water can only be considered as effective if these means are of a capacity to prevent large amounts of water from accumulating on the deck i.e. many thousands of tonnes per hour which is far beyond the capacities fitted at the time of the adoption of these regulations. Such high efficiency drainage systems may be developed and approved in the future (based on guidelines to be developed by the International Maritime Organisation)

The garage doors fitted at the aft end of some high speed craft are not considered to be efficient enough in this instance unless calculations of drainage are provided with evidence that the sinkage caused by the additional water on deck does not result in an equivalent head of water on the external face of the 'garage door' which will prevent the door from collapsing.

Paragraph 1.3 of Annex 2 of The Agreement (Ref.5).

1. The amount of assumed accumulated water-on-deck may, in addition to any reduction in accordance with paragraph 1.1, be reduced for operations in geographically defined restricted areas. These areas are designated in accordance with the Significant Wave Height (h_s) defining the area and are detailed in Annex 1 to the Agreement.
2. If the Significant Wave Height (h_s), in the area concerned, is 1.5m or less then no additional water is assumed to accumulate on the damaged ro-ro deck. If the Significant Wave Height in the area concerned is 4.0m or more then the height of the assumed accumulated water shall be the value calculated in accordance with paragraph 1.1. Intermediate values to be determined by linear interpolation (**see Fig 3**).
3. The height h_w is kept constant therefore the amount of added water is variable as it is dependent upon the heeling angle and whether at any particular heeling angle the deck edge is immersed or not. (**see Fig 4**). It should be noted that the assumed permeability of the car deck spaces is to be taken as 90% (MSC/Circ.649 and 2.6 of the 2000 HSC Code refers), whereas other assumed flooded spaces permeability's are to be those prescribed in 2.6 of the HSC Codes.
4. If the calculations to show compliance with the Agreement relate to a Significant Wave Height less than 4.0m that restricting Significant Wave Height must be recorded on the vessel's passenger vessels permit to operate certificate as a regional restriction.

Paragraphs 1.4 / 1.5 of Annex 2 of The Agreement (Ref.5).

As an alternative to complying with the new stability requirements of paragraphs 1.1 or 1.3 an Administration may accept proof of compliance via model tests. The model test requirements are detailed in Annex 3 to the Agreement. Guidance notes on the model tests are contained in Part 5 of this Appendix to this document.

Paragraph 1.6 of Annex 2 of The Agreement (Ref.5).

Conventionally derived HSC Code limiting operational curve(s) (KG or GM) may not remain applicable in cases where "water on deck" is assumed under the terms of the Agreement and may be necessary to determine revised limiting curve(s) which take into account the effects of this added water. To this effect sufficient calculations corresponding to an adequate number of operational draughts and trims must be carried out and the Stability Information Booklet re-approved as necessary.

Note

Revised limiting operational KG/GM Curves may be derived by iteration, whereby the minimum excess GM resulting from damage stability calculations with water on deck is added to the input KG (or deducted from the GM) used to determine the damaged freeboards (f_i), upon which the quantities of water on deck are based, this process being repeated until the excess GM becomes negligible.

It is anticipated that operators would begin such an iteration with the maximum KG/minimum GM which could reasonably be sustained in service and would seek to manipulate the resulting deck bulkhead arrangement to minimise the excess GM derived from damage stability calculations with water on deck.

Paragraph 2.1 of Annex 2 of The Agreement (Ref.5).

As for conventional HSC Code damage requirements bulkheads inboard of the line applied under 2.6.6.2 of the 1994 HSC Code or by 2.6.7.2 of the 2000 HSC Code are considered intact in the event of side collision damage.

Paragraph 2.2 of Annex 2 of the Agreement (Ref.5)

If side structural sponsons are fitted to enable compliance with this regulation, and as a consequence there is an increase in the breadth (B) of the ship and hence the vessel's transverse extent of side damage from the ship's side, such modification shall not cause the relocation of any existing structural parts or any existing penetrations of the main transverse watertight bulkheads below the bulkhead deck.(see Fig 5)

Paragraph 2.3 of Annex 2 of the Agreement (Ref.5)

1. Transverse or longitudinal bulkheads/barriers which are fitted and taken into account to confine the movement of assumed accumulated water on the damaged ro-ro deck need not be strictly "watertight". Small amounts of leakage may be permitted subject to the drainage provisions being capable of preventing an accumulation of water on the "other side" of the bulkhead/barrier. In such cases where scuppers become inoperative as a result of a loss of positive difference of water levels other means of passive drainage must be provided.
2. The height (B_h) of transverse and longitudinal bulkheads/ barriers shall be not less than $(8 \times h_w)$ metres, where h_w is the height of the accumulated water as calculated by application of the residual freeboard and Significant Wave Height (paras 1.1 and 1.3 refers). However in no case is the height of the bulkhead/barrier to be less than the greatest of:

- (a) 2.2 metres; or
 - (b) the height between the bulkhead deck and the lower point of the underside structure of the intermediate or hanging car decks, when these are in their lowered position. It should be noted that any gaps between the top edge of the bulkhead deck and the underside of the plating must be "plated-in" in the transverse or longitudinal direction as appropriate. **(see Fig 6)**.
3. Bulkheads/barriers with a height less than that specified above, may be accepted if model tests are carried in accordance with Part 5 of this Appendix to confirm that the alternative design ensures appropriate standard of survivability.
 4. Care needs to be taken when fixing the height of the bulkhead/ barrier such that the height shall also be sufficient to prevent progressive flooding within the required stability range. This range is not to be prejudiced by model tests.
Note: The range may be reduced to 10 degrees provided the corresponding area under the curve is increased (MSC. 64/22 refers)

Paragraph 2.5.1 of Annex 2 of the Agreement (Ref.5)

1. The area "A" relates to permanent openings. It should be noted that the "freeing ports" option is not suitable for vessels which require the buoyancy of the whole or part of the superstructure in order to meet the criteria. The requirement is that the freeing ports shall be fitted with closing flaps to prevent water entering, but allowing water to drain.
2. These flaps must not rely on active means. They must be self-operating and it must be shown that they do not restrict outflow to a significant degree. Any significant efficiency reduction must be compensated by the fitting of additional openings so that the required area is maintained.
Refer also to comments above on Para 1.2 of the Agreement relating to "garage doors".

Paragraph 2.5.2 of Annex 2 of The Agreement (Ref.5)

For the freeing ports to be considered effective the minimum distance from the lower edge of the freeing port to the damaged waterline shall be at least 1.0m. The calculation of the minimum distance shall not take into account the effect of any additional water on deck. **(see Fig 7)**

Paragraph 2.5.3 of Annex 2 of The Agreement (Ref.5).

Freeing ports must be sited as low as possible in the side bulwark or shell plating. The lower edge of the freeing port opening must be no higher than 2cm above the bulkhead deck and the upper edge of the opening no higher than 0.6m. **(see Fig 8)**

Note: Spaces to which paragraph 2.5 applies, ie those spaces fitted with freeing ports or similar openings, shall not be included as intact spaces in the derivation of the intact and damage stability curves.

Paragraph 2.6 of Annex 2 of The Agreement (Ref.5).

1. The statutory extent of damage is to be applied along the length of the ship. The damage may not affect any bulkhead or may only affect a bulkhead below the bulkhead deck or only a bulkhead above the bulkhead deck or various combinations.
2. All transverse and longitudinal bulkheads/barriers which constrain the assumed accumulated amount of water must be in place and secured at all times when the ship is at sea.
3. In those cases where the transverse bulkhead/barrier is damaged the accumulated water-on-deck shall have a common surface level on both sides of the damaged bulkhead/barrier at the height h_w (see Fig 9).

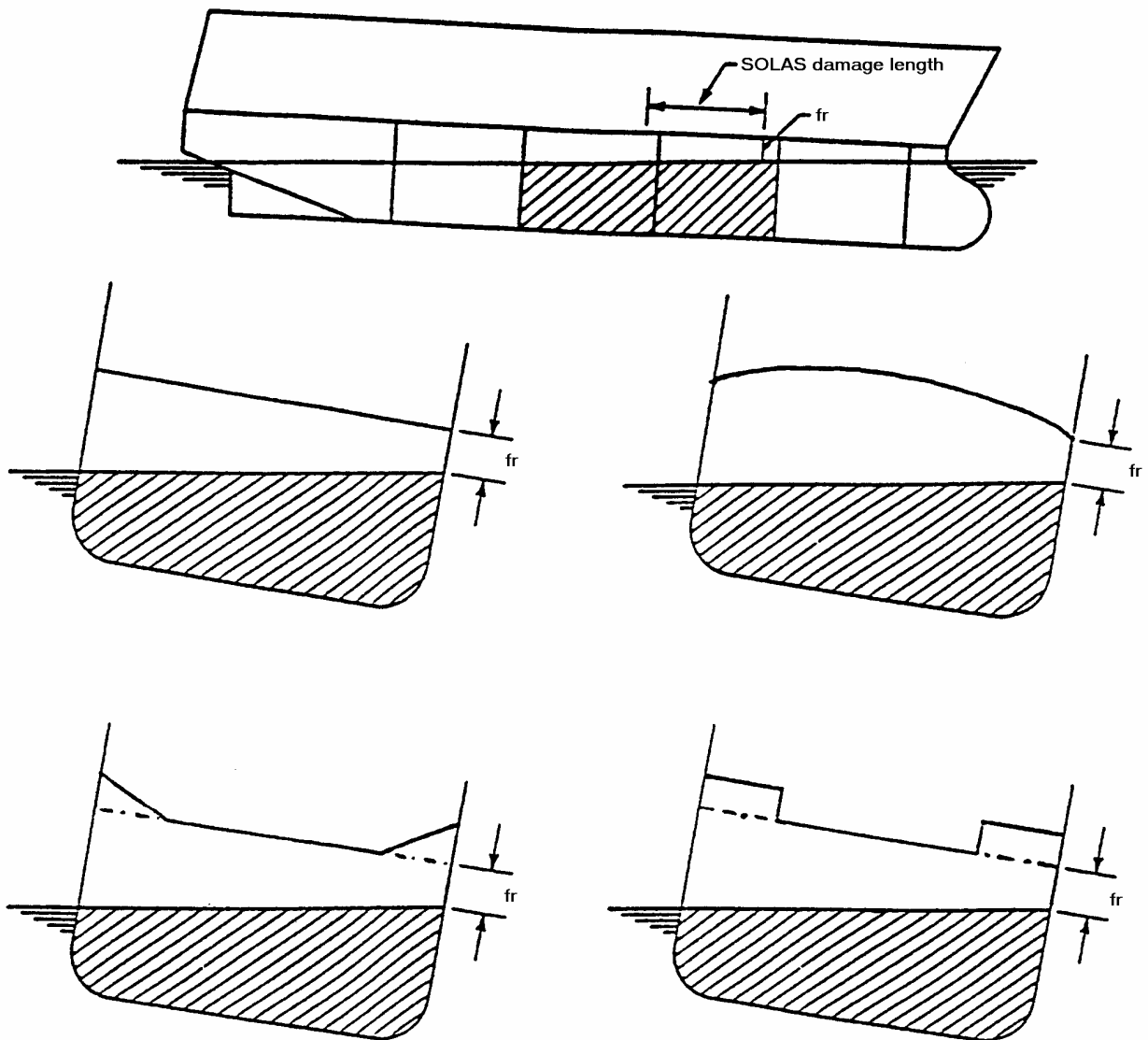
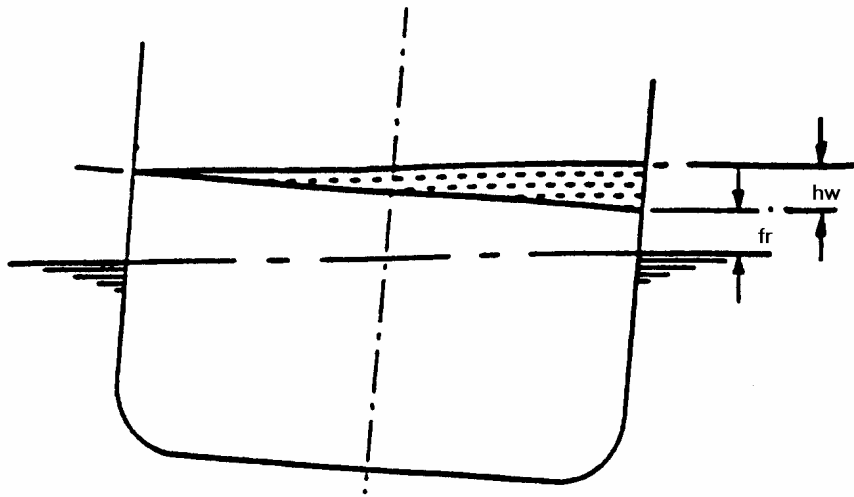
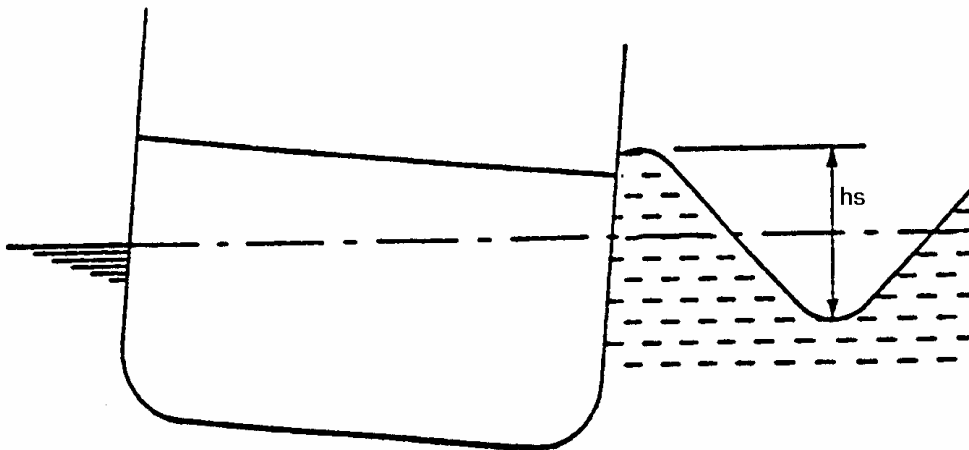

Figure 1



1. If $f_r \geq 2.0$ metres, height of water on deck (h_w) = 0.0 metres
2. If $f_r \leq 0.3$ metres, height of water on deck (h_w) = 0.5 metres

Figure 2



1. If $h_s \geq 4.0$ metres, height of water on deck is calculated as per figure 3
 2. If $h_s \leq 1.5$ metres, height of water on deck (h_w) = 0.0 metres
- For example
 If $f_r = 1.15$ metres and $h_s = 2.75$ metres,
 height $h_w = 0.125$ metres

Figure 3

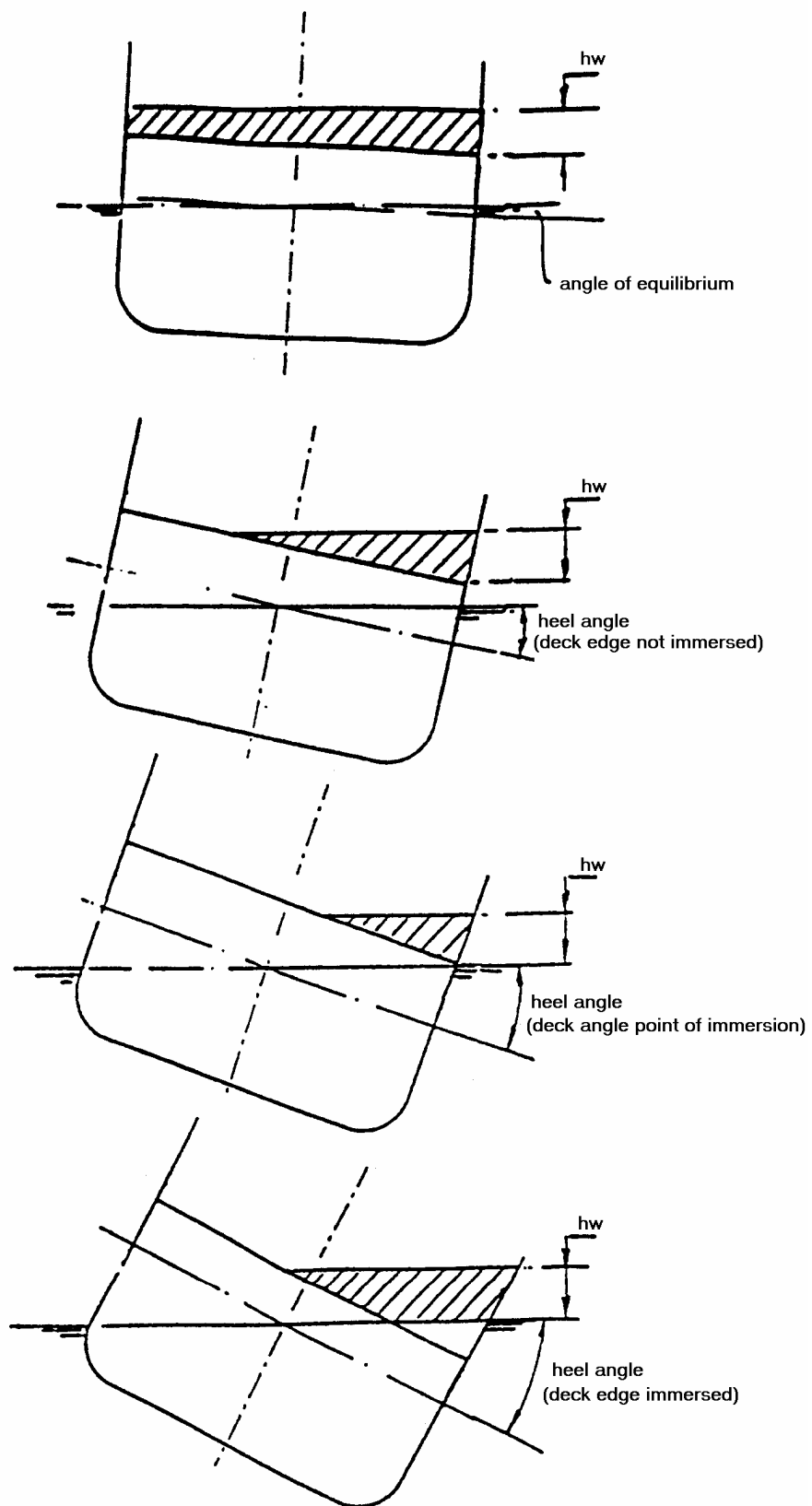
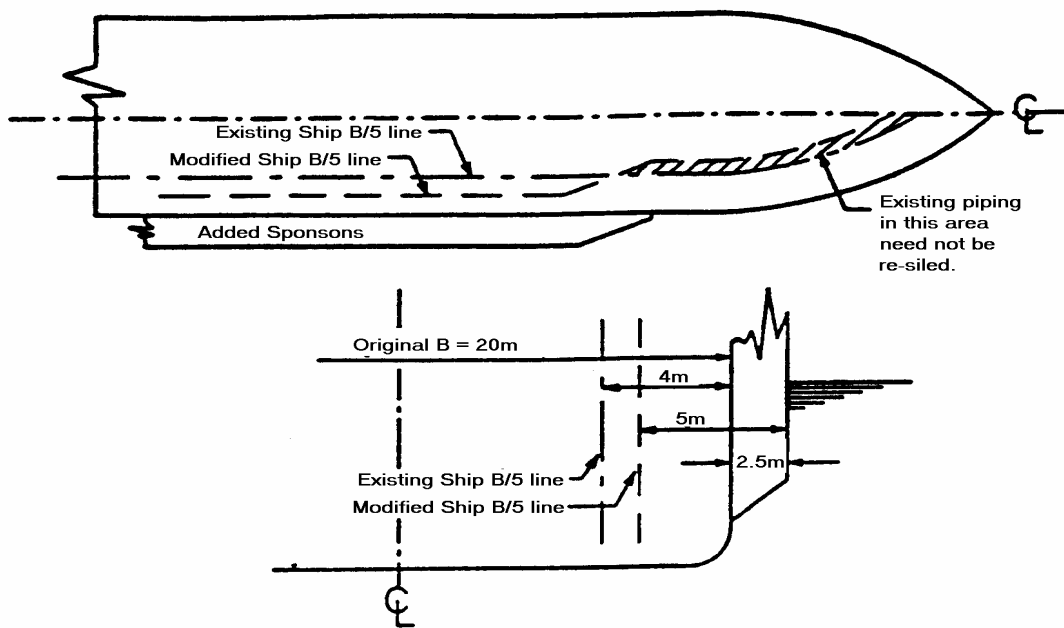

Figure 4



(Note: the phrase B/5 refers to the transverse damage extent required by the 1994 or the 2000 HSC Code for side damages).

Figure 5

Ships without hanging car decks

Example 1

Height of water on deck = 0.25 metres

Minimum required height of barrier = 2.2 metres

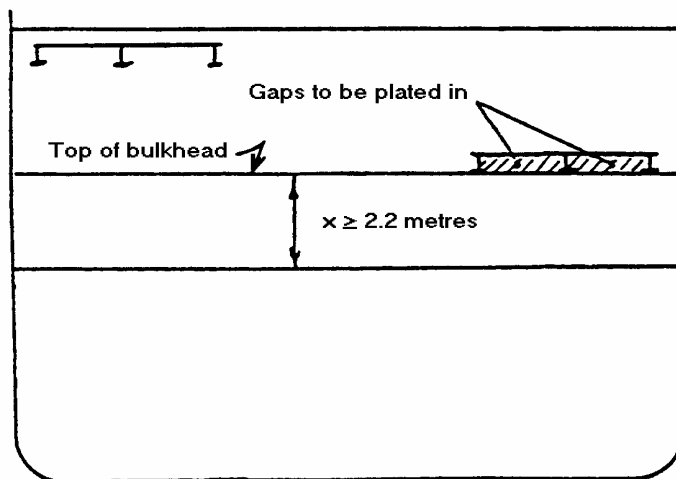

Ships with hanging car deck (in way of the barrier).

Example 2

Height of water on deck (h_w) = 0.25 metres

Minimum required height of barrier = x

Figure 6

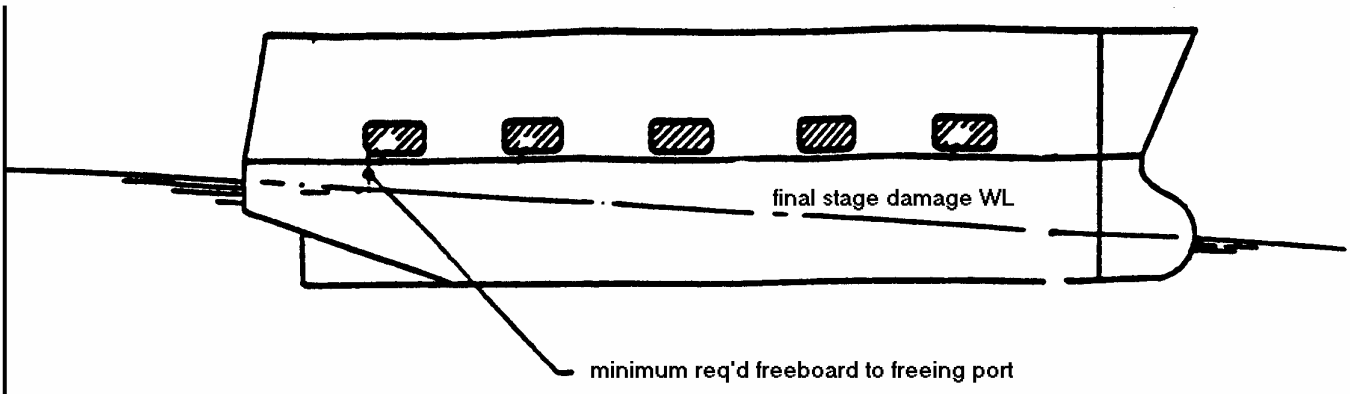

Figure 7

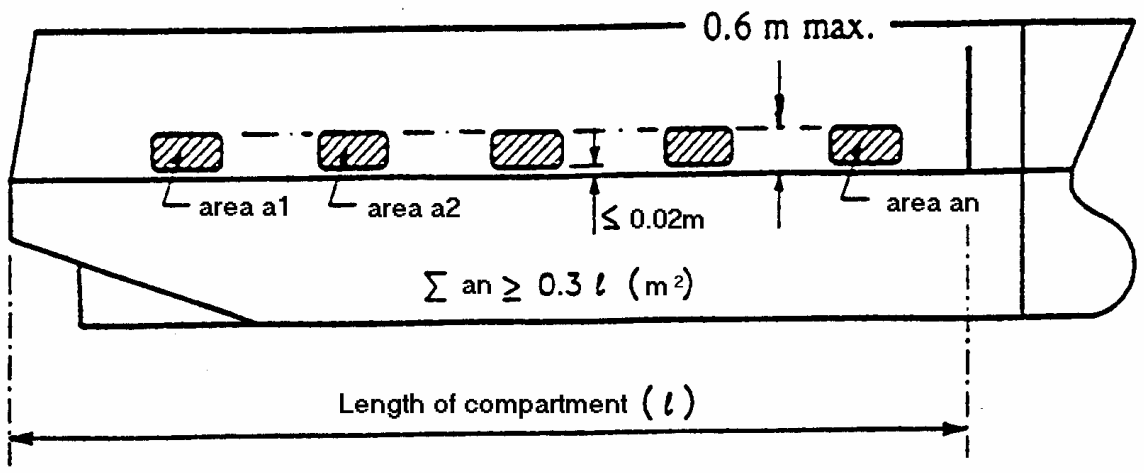
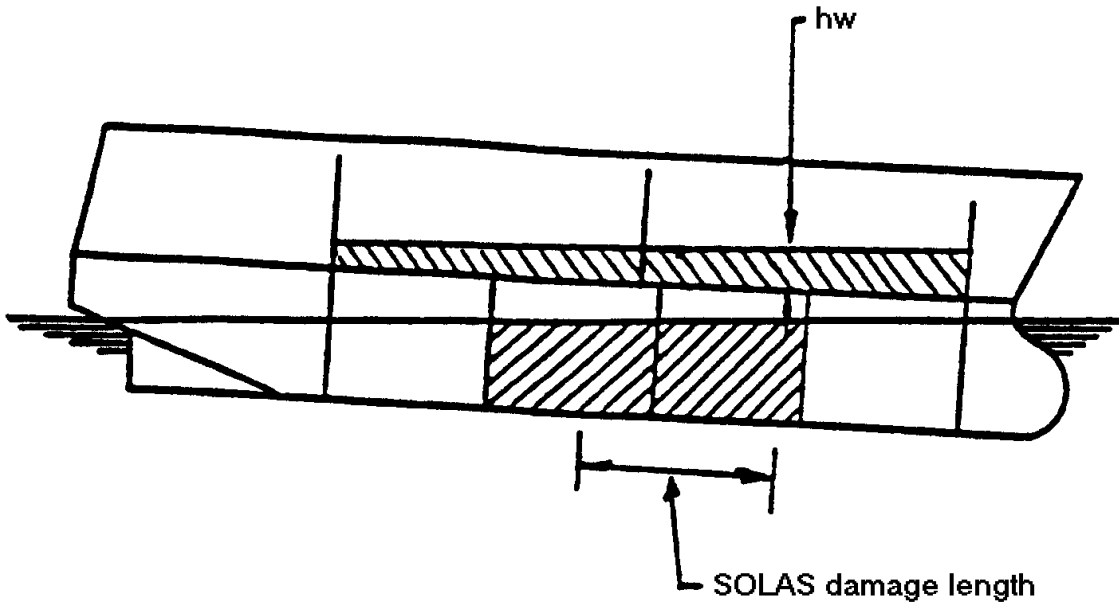
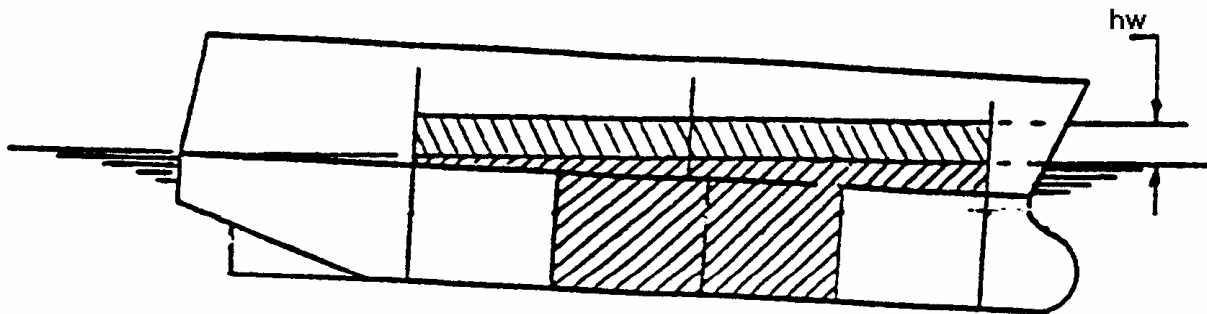

Figure 8



(Note: SOLAS damage length refers to side damage length of HSC Code.)
Deck edge not immersed



Deck edge immersed

Figure 9

5 Guidance Notes on Appendix to Annex 2 of the Stockholm Agreement (Model Test Method) (SLF40 /INF.14 annex 2, amended for HSC).

Purpose

The purpose of these notes to ensure uniformity in the methods employed in the construction and verification of the model as well as in the undertaking and analyses of the model tests, while appreciating that available facilities and costs will affect in some way this uniformity.

Paragraph 1 of Appendix to Annex 2 of the Agreement (Ref. 5.) – Objectives

The content of paragraph 1 of the Appendix to Annex 2 to the Regional Agreement is self explanatory.

Paragraph 2 of Appendix to Annex 2 of the Agreement (Ref. 5.) - Ship Model

2.1 The material of which the model is made is not important in itself, provided that the model both in the intact and damaged condition is sufficiently rigid to ensure that its hydrostatic properties are the same as those of the actual ship and also that the flexural response of the hull in waves is negligible.
It is also important to ensure that the damaged compartments are modelled as accurately as practicably possible to ensure that the correct volume of flood water is represented.

Since ingress of water (even small amounts) into the intact parts of the model will affect its behaviour, measures must be taken that this ingress does not occur.

2.2 Model particulars

.1 In recognising that scale effects play an important role in the behaviour of the model during tests it is important to ensure that these effects are minimised as much as practically possible. The model should be as large as possible since details of damaged compartments are easier constructed in larger models and the scale effects are reduced. It is therefore recommended that the model length is not less than that corresponding to 1:40 scale. However it is required that the model is not less than 3 metres long at the subdivision water line.

.2

(a) The model in way of the assumed damages must be as thin as practically possible to ensure that the amount of flood water and its centre of gravity is adequately represented.

It is recognised that it may not be possible for the model hull and the elements of primary and secondary subdivision in way of the damage to be constructed with sufficient detail and due to these constructional limitations it may not be possible to calculate accurately the assumed permeability of the space.

- (b) It has been found during tests that the vertical extent of the model can affect the results when tested dynamically. It is therefore required that the ship is modelled to at least three superstructure standard heights above the bulkhead (freeboard) deck so that the large waves of the wave train do not break over the model.
- (c) It is important that not only the draughts in the intact condition are verified but also that the draughts of the damaged model are accurately measured for correlation with those derived from the damaged stability calculation. After measuring the damaged draughts it may be found necessary to make adjustments to the permeability of the damaged compartment by either introducing intact volumes or by adding weights. However it is also important to ensure that the centre of gravity of the flood water is accurately represented. In this case any adjustments made must err on the side of safety.
- (d) If the model is required to be fitted with barriers on deck and the barriers are less than the height required as per paragraph 2.3 of Annex 2 of this Agreement the model is to be fitted with CCTV so that any "splashing over" and any accumulation of water on the undamaged area of the deck can be monitored. In this case a video recording of the event is to form part of the tests records.

3 In order to ensure that the model motion characteristics represent those of the actual ship it is important that the model is both inclined and rolled in the intact condition so that the intact GM and the mass distribution are verified. The transverse radius of gyration of the actual ship is not to be taken as being greater than 0.4B and the longitudinal radius of gyration is not to be taken as being more than 0.25L.

The transverse rolling period of the model (in seconds) is to be obtained by:

$$\frac{2\pi \times 0.4B}{\sqrt{g \times GM \times \lambda}}$$

where: GM = metacentric height of the actual (intact) ship
g = acceleration due to gravity
λ = scale of model
B = breadth of actual ship

Note:

While inclining and rolling the model in the damage condition may be accepted as a check for the purpose of verifying the residual stability curve such tests are not to be accepted in lieu of the intact tests.

Nevertheless the damaged model must be rolled in order to obtain the rolling period required to perform the tests, as per paragraph 3.1 of the Agreement (Ref. .5)

A non-standard method for inclining may need to be adopted for HSC multihull vessels. Refer to MCA Headquarters for advice on this.

.4 The contents of this paragraph is self-explanatory. It is assumed that the ventilators of the damage compartment of the actual ship are adequate for unhindered flooding and movement of the flood water. However in trying to scale down the ventilating arrangements of the actual ship undesirable scale effects may be introduced. In order to ensure that these do not occur it is recommended to construct the ventilating arrangements to a larger scale than that of the model, ensuring that this does not affect the flow of water on the car deck.

.5.2 The isosceles triangular profile of the prismatic damage shape is that corresponding to the load waterline.
Additionally in cases where side casings of width less than the transverse extent of the side damage are fitted and in order to avoid any possible scale effects, the damage length in way of the side casings must not be less than 2 metres.

Paragraph 3 of Appendix to Annex 2 of the Agreement (Ref. 5) - Procedure for experiments

3.1 - Wave Spectra

The JONSWAP spectrum is to be used as this describes fetch and duration limited seas which correspond to the majority of the conditions worldwide. In this respect it is important that not only the peak period of the wave train is verified but also that the zero crossing period is correct.

.1 Corresponding to a peak period of $4\sqrt{H_s}$ and given that the enhancement factor γ is 3.3, the zero crossing period is not to be greater than:
 $[T_p/(1.20 \text{ to } 1.28)] \pm 5\%$

.2 The zero crossing period corresponding to a peak period equal to the rolling period of the damaged model and given that the γ factor is to be 1, is not to be greater than:

$$[T_p/(1.3 \text{ to } 1.4)] \pm 5\%$$

noting that if the rolling period of the damaged model is greater than $6\sqrt{H_s}$, the peak period is to be limited to $6\sqrt{H_s}$.

Note:

It has been found that it is not practical to set limits for zero crossing periods of the model wave spectra according to the nominal values of the mathematical formulae. Therefore an error margin of 5% is allowed.

It is required that for every test run the wave spectrum is recorded and documented. Measurements for this recording are to be taken in the immediate vicinity of the model (but not on the leeside)- see figure 1 - and also near the wavemaking machine.

It is also required that the model is instrumented so that its motions (roll, heave and pitch) as well as its attitude (heel sinkage and trim) are monitored and recorded throughout the test.

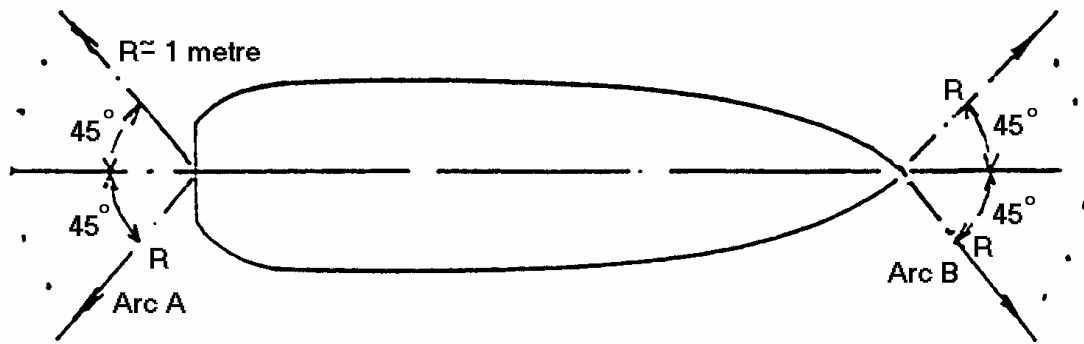

The "near the model" wave measuring probe is to be positioned either on arc A or arc B
Figure 1

Paragraphs 3.2, 3.3, and 3.4

The contents of these paragraphs are considered to be self-explanatory.

Paragraph 3.5 - Simulated damages

Extensive research carried out for the purpose of developing appropriate criteria for new vessels has clearly shown that in addition to the GM and freeboard being important parameters in the survivability of passenger ships, the area under the residual stability curve up to the angle of maximum GZ is also an other major factor. Consequently in choosing the worst HSC damage for compliance with the requirement of paragraph 3.5.1 the worst damage is to be taken as that which gives the least area under the residual stability curve up to the angle of the maximum GZ.

Paragraph 4 of Appendix to Annex 2 of the Agreement (Ref. 5) - Survival Criteria

The contents of this paragraph are considered self-explanatory.

Paragraph 5 of Appendix to Annex 2 of the Agreement (Ref. 5) - Test Approval

The following documents are to be part of the report to the Administration:

- (a) damage stability calculations for worst HSC side damage and midship HSC side damage (if different);
- (b) general arrangement drawing of the model together with details of construction and instrumentation;
- (c) inclining experiment and rolling test reports;
- (d) calculations of actual ship and model rolling periods;
- (e) nominal and measured wave spectra (near the wavemaking machine and near the mode respectively);
- (f) representative records of model motions, attitude and drift; and

(g) relevant video recordings.

Note:

All tests must be witnessed by the Administration.

6 Merchant Shipping (Ro-Ro Passenger Ship Survivability) Regulations 1997 (S.I. 1997 No. 647)

6.1 General

6.1.1 These regulations implement a Regional Agreement (IMO Circular letter 1891 in accordance with SOLAS 1995 Conference Resolution 14 refers) entitled "Agreement Concerning Specific Stability Requirements for Ro-Ro Passenger Ships Undertaking Regular Scheduled Voyages Between or to or from Designated Ports in North West Europe and the Baltic Sea".

6.1.2 The general requirement is that all Ro-Ro passenger ships (including high speed craft) will comply with SOLAS 90 or equivalent and consider the effects of water on the vehicle deck, the amount of water being dependent on the freeboard after assumed side damage and the Significant Wave Height in the area of intended operation.

6.1.3 References to regulation numbers in this Part refer to regulation numbers of the above regulations.

6.1.4 The Agreement, commonly known as the "Stockholm Agreement", is reproduced in Merchant Shipping Notice MSN 1673(M) and contains the technical requirements to be complied with. See also paragraph 6.8 of this Appendix (C).

6.1.5 Signatories to the Agreement prepared "guidance notes on the annexes of the Agreement" which were presented in a paper to the International Maritime Organisation (IMO). The text of the two annexes to the paper, SLF 40/INF.14, are reproduced in Parts 2, 3, 4, and 5 of this Appendix (C).

6.2 Interpretation (Regulation 2)

This Regulation provides definition of terms used in the regulations one of which establishes to which ships the regulations apply, that is those operating a "regular scheduled service".

6.3 Value of A/A_{max} (Regulation 5)

High-speed craft are assumed to have a value of A/A_{max} of 100%.

6.4 Construction (Regulation 6)

The date by which a vessel is to fully comply with the requirements of the Agreement is determined by the value of the A/A_{max} . This compliance date is fixed and no extension will be allowed by partial modifications to enhance the A/A_{max} value. Note: New building vessels and vessels which are newly in operation in UK waters must comply with Stockholm Agreement prior to commencing service.

6.5 Seasonal Operation (Regulation 7)

The Significant Wave Heights to be considered in the Agreement are for “year round operations”. This regulation allows for a reduction in the wave height where it can be justified for the restricted period of operation, e.g. summer operation only.

6.6 Significant Wave Heights for Domestic Routes (Regulation 8)

The wave heights for international voyages may be considered excessive for certain domestic routes and this regulation allows for reduced heights to be considered where they can be justified.

6.7 Certificates

6.7.1 For those vessels not yet complying fully with the requirements of the Agreement a certificate entitled Evidence of Compliance 1 Document is issued. This document indicates the ships A/A_{\max} value.

6.7.2 Those vessels fully complying with the requirements of the Agreement are issued with a certificate entitled Evidence of Compliance 2 Document. This document states the Significant Wave Height that the ship may operate in. The Passenger Safety Certificate or Passenger Certificate will be endorsed to show this Significant Wave Height, together with any restrictions which may have been imposed, e.g. restricted period of operation. Surveyors should note that the Significant Wave Height stated should not be lower than that required for the area of operation of the vessels.

6.8 Stockholm Agreement (MSN 1673 (M))

6.8.1 Guidance notes

Annexes 1 and 2 of IMO document SLF 40/INF.14 are appropriate notes on the uniform application of Annexes 1 and 2 of the Agreement. Annex 1 deals with the stability requirements pertaining to the Agreement while Annex 2 deals with the Model Test Method. Both annexes of the IMO document are reproduced at Part 3, 4, 5 and 6 of this Appendix (C).

6.8.2 Required submissions

6.8.2.1 Calculations

Where calculations are the decided method to show compliance, the submission should include, for a new ship, that the requirements of the HSC Code should be followed, however paragraph 5.6.2 of the Instructions for the Guidance of Surveyors Passenger Ship Construction Classes 1,II and IIA may be used as a further guide. In addition to quoting the Significant Wave Height on which the calculations are based, the summary of the damage case calculations is to indicate the freeboards after damage and the amount of water on deck that has been considered in each case. For a vessel which has previously been submitted to the certifying authority, those details and plans referred to in the HSC Code may not be required. For the vessel in question, the

surveyor will advise the owner/consultant, referring to MCA Headquarters for advice if necessary.

6.8.2.2 Model test

Where it has been decided that model tests are to be undertaken, calculations are to be submitted which show the worst HSC Code damage (defined in paragraph 3.5 of Part 5 of this Appendix (C)) required by the regulations. However, if this damage is outside of $\pm 10\%L$ from midships the worst midship damage with regard to freeboard is also to be submitted. The extent and degree of modelling and the model test program together with the calculation results are to be agreed by the Certifying Authority.

6.8.2.3 Model details

Regarding modelling of double bottom tanks, the following rules should be obeyed:-

(i) Where these tanks are included in the damage case, they are to be accurately modelled with particular attention paid to the damage opening, where both the inner and outer bottom should include a sharp edged V cut-out full penetration with horizontal, vertical, and longitudinal extents as described in the appropriate HSC Code;

(a) Where these tanks are intentionally omitted from the damage case, to give a worse "lesser" damage case, then they may be modelled as a solid block.

(b) Where these tanks are permanently filled with ballast etc, but lie within the HSC Code extent of side damage, they should be modelled as in (a) above except that their contents should be included as a weight in the intact condition. This weight shall be removed upon opening of the damage in the model side and flooding of the space takes place.

6.8.3 Approval after model testing

Two copies of the test report and videos are required for retention by the Certifying Authority. All details and reports are to be held on the CM 18/03 file. As per procedure, copies should be sent to IMO upon completion, including the Certificate of Compliance 2.

* * *