



Doosan Babcock

Part of Doosan Power Systems

Research and Development

Report Title: Demonstration of an Oxyfuel Combustion System

Authors: E D Cameron, D W Sturgeon, J W Rogerson and H R Seneviratne

Report No.:	RD-10-025	Customer :	DECC
Issue :	3	Order No.:	CAT0602
Project/Sub-Proj :	69501/SE1160	Sponsor :	Research & Development Centre
DHI Reference :	OX-H3a-07 012-3	Report Type :	Final Report
IFS Number :	N/A	Date of Issue :	8 th February 2011

Final Report

DISTRIBUTION LIST**Customer**

Department of Energy and Climate Change (Black & Veatch)	C Warren	3*
Scottish and Southern Energy PLC	A Buretta	1
Air Products PLC	V White	1
Drax Power Limited	E Rowe	1
DONG Energy	T Pedersen	1
E.ON UK PLC	R Irons	1
EDF Energy PLC	E Joos	1
Scottish Power Limited	D Campbell	1
UK Coal PLC	P Garner	1
Vattenfall AB	S Rydberg	1
University of Nottingham	C Snape	1
Imperial College London	A Kempf	1

Doosan Babcock

Director R&D → Manager Strategy & Planning → Manager Projects → Manager R&D Staff	R A Dennis → C A Cantley → M Cousland → B Livesey	1*
VP Power → Director Power Sales → Director Power → Director CCS → Director Services Technology → Director Technology Policy and Liaison → Library	J L King → D M Allen → D McQueen → M R Bryant → J L Thomson → J M Farley → Library (Master Copy)	1*
Library (Lending Copy)	M McNeillie	1*
Director Engineering – Doosan Babcock	C Grieve	1
Chief Engineer – Doosan Babcock	M J Smith	1
Centre Of Excellence (COE)	S W Cameron → J Macphail	1
Project Manager/Sponsor	E McCulloch	1
Principal Investigator/Lead Engineer	E D Cameron → Project File	1*
Others	F D Fitzgerald G Hesselmann → S D Cameron → C McGhie → D Sturgeon P Holland-Lloyd R Panesar G Sims → CFD Team J Smith	1* 1 1 1 1 1

Doosan Power Systems - Americas

Chief Engineer USA	K Morris	1
Director Business Development, Carbon Reduction	S Black	1

TOTAL		30
-------	--	----

* Denotes hard copies

AMENDMENT CONTROL

Issue	Section	Reason for Amendment
1		First Issue
2	8,9	Minor revisions to improve clarity of Discussion and Figures
3	11	Implications of project results added at DECC's request to satisfy project agreement.

Author :



E D Cameron

Date:

8th February 2011

Approved for Issue by :



G J Hesselmann

Date:

8th February 2011

In the event that this report is provided as part of a contract obligation, this report is provided for the sole use and benefit of the Purchaser subject to the agreed Terms and Conditions of Contract, and Doosan Power System's responsibilities to the Purchaser are strictly governed by those Terms. Doosan Power System accepts no responsibility in relation to this report to anybody other than the Purchaser.

SUMMARY

The OxyCoal 2 project was undertaken by Doosan Babcock in collaboration with Imperial College London, University of Nottingham, Scottish and Southern Energy PLC, Air Products PLC, DONG Energy, Drax Power Limited, EDF Energy PLC, E.ON UK PLC, ScottishPower Limited, Vattenfall AB, and UK Coal PLC. Following successful completion of DTI Technology Programme project TPC/00/00404/00/00 *OxyCoal_UK Phase 1: Fundamentals and Underpinning Technologies*, a purpose-designed oxyfuel demonstration facility (Doosan Babcock's 90MW_t Clean Combustion Test Facility (CCTF)) was built, and testing was undertaken to demonstrate an oxyfuel combustion system of a type and size (40MW_t) applicable to new build and retrofit advanced supercritical boiler plant. This report describes the design, HAZOP, installation and commissioning of the oxyfuel equipment and the design, manufacture and parametric testing of the 40MW_t OxyCoal™ burner.

Design, installation and commissioning of the additional process equipment needed for oxyfuel operation was successfully completed in July 2009.

The OxyCoal™ burner test programme was undertaken in three parts: firstly the isothermal performance of the burner was characterised; then the ability of the burner to operate safely under air and oxyfuel conditions was demonstrated; and finally parametric testing was undertaken. The test programme was successfully completed in April 2010.

The main conclusions of the OxyCoal 2 project are as follows:

- The CCTF was successfully converted to oxyfuel operation.
- A full scale 40MW_t OxyCoal™ burner was successfully demonstrated under both air and oxyfuel operation. Safe and stable operation was achieved across a wide operational envelope. Oxyfuel flame stability was comparable to air-firing experience.
- Safe and smooth transitions between air- and oxyfuel-firing were demonstrated; three different transition methodologies were proven.
- Turndown from full load to 40% load was demonstrated. Stable and well rooted flames were observed across the whole load range. Flame length decreases with decreasing load (as for air-firing).
- Combustion efficiency, as expressed by carbon-in-ash, unburned loss, and CO, is comparable for air- and oxyfuel-firing.
- Flame shape under air and oxyfuel conditions is similar. Under oxyfuel-firing the flame is slightly narrower than for air-firing, this is consistent with expectations based on CFD modelling undertaken during the burner design.
- NO_x generated by the combustion process is significantly lower under oxyfuel firing, by a factor of ca.2, when expressed as mg/MJ. Oxyfuel has the additional benefit of virtually eliminating NO_x emissions with almost all the NO_x being captured in the flue gas compression plant.
- SO₂ produced by the combustion process under oxyfuel firing conditions is lower than for air-firing; this is due to removal of SO₂ in the process (dissolution in the direct contact coolers and absorption on the fly ash). The SO₂ is likely to be captured completely by the CO₂ compression and cleaning plant, leading to no emissions to the environment.

- There are differences in the measured absorbed heat flux profiles observed for air and oxyfuel firing. These are explainable by differences in operating conditions and ash concentration.
- Realistic CO₂ levels in the combustion plant were achieved (in excess of 75% v/v dry, and up to 85% v/v dry).
- A number of practical lessons were learned
 - The need to verify measurements (via a system mass balance) to identify instrument issues (e.g. CO₂ analyser error at high CO₂ concentrations).
 - The ability to reduce air in-leakage by balancing pressures through the draught plant.
 - The impact of fan interactions during the transition between air- and oxyfuel-firing.
- All the project objectives were achieved.

CONTENTS

1. INTRODUCTION	7
2. OBJECTIVES	7
3. OXYFUEL TECHNOLOGY	7
4. THE CLEAN COMBUSTION TEST FACILITY	8
4.1. Layout Prior to Oxyfuel Upgrade	8
4.2. Modifications for Oxyfuel Combustion	10
4.3. Hazard and Operability (HAZOP) Study	11
4.3.1. Hazard Identification	11
4.3.2. Designing out the Hazards	12
5. OXYCOAL™ BURNER	13
6. BURNER MODELLING	13
7. TEST FACILITY COMMISSIONING	14
8. 40MW_t OXYCOAL™ BURNER TESTING	14
8.1. Test Plan	14
8.1.1. Isothermal Tests	14
8.1.2. Burner Proving	15
8.1.3. Parametric Tests	15
8.2. Coals	15
8.3. Isothermal Tests	15
8.4. OxyCoal™ Combustion: Burner Proving	16
8.4.1. Plant Operability	16
8.4.2. Air Ingress	16
8.4.3. Flame Stability	17
8.4.4. Turndown	17
8.5. OxyCoal™ Combustion: Parametric Testing	17
8.5.1. CO ₂ Concentration	17
8.5.2. NO _x Performance	18
8.5.3. Production of SO _x	18
8.5.4. Combustion Efficiency	18
8.5.5. Heat Flux	19
8.5.6. Boiler Thermal Performance	19
8.5.7. Flame Observations	19
9. ANTICIPATED PERFORMANCE OF UTILITY PLANT	19
9.1. Air-Firing versus Oxyfuel-Firing	19
9.2. Implications of Test Results for Future Oxyfuel Plant	20
9.3. Economic Assessment	20
10. CONCLUSIONS	21
11. IMPLICATIONS OF PROJECT RESULTS	22
REFERENCES	24
ACKNOWLEDGEMENTS	25

1. INTRODUCTION

Oxyfuel combustion represents one of the more promising of the technologies currently being developed for CO₂ capture. The world wide market for CO₂ capture equipment is likely to be considerable, and it is strategically important for power plant operators and equipment manufacturers to have a developed product within a timescale consistent with the market for this technology. The OxyCoal 2 project *CAT0602 – Demonstration of an Oxyfuel Combustion System* is one of a number of development projects that aim to prove the oxyfuel combustion technology at large scale by testing on Doosan Babcock's Clean Combustion Test Facility (CCTF) in Scotland. The OxyCoal 2 project started in December 2007. The project team comprises of the following organisations: Doosan Babcock (Lead), Imperial College London and University of Nottingham. Scottish and Southern Energy PLC, Air Products PLC, DONG Energy, Drax Power Limited, EDF Energy PLC, E.ON UK PLC, Scottish Power Limited, Vattenfall AB, and UK Coal PLC are sponsor participants, with Scottish and Southern Energy PLC acting as prime sponsor.

This report describes the design, HAZOP, installation and commissioning of the oxyfuel equipment, and the design, manufacture and parametric testing of the 40MW_t OxyCoal™ burner.

2. OBJECTIVES

The overall aim of the project is to demonstrate an oxyfuel combustion system of a type and size (40MW_t) applicable to new build and retrofit advanced supercritical oxyfuel plant, with the following specific objectives:

- Demonstrate successful performance of a full-scale (40MW_t) oxyfuel burner firing at conditions pertinent to the application of an oxyfuel combustion process in a utility power generating plant.
- Demonstrate performance of an oxyfuel burner with respect to flame stability, NO_x, flame shape and heat transfer characteristics.
- Demonstrate the operational envelope of an oxyfuel burner with respect to flame stability, turndown, start-up, shutdown and the transition between air- and oxyfuel-firing.
- Demonstrate safe operation of an oxyfuel combustion process under realistic operating conditions.
- Generate sufficient oxyfuel combustion process performance data to inform future investment decisions.
- Demonstrate the level of technology readiness of the oxyfuel combustion process.

3. OXYFUEL TECHNOLOGY

The oxyfuel combustion process is based on excluding the inert components of air from the combustion process. These components, mainly composed of nitrogen gas, pass through the boiler system during conventional air firing without chemical change. The presence of the inerts does however assist the process of heat transfer from the flue gas to the power cycle working fluid (steam) in two ways:

1. By diluting the combustion process sufficiently to yield acceptable flame temperatures that enable operation within a conventional water tube walled furnace, and
2. By increasing the gas weight available for convective heat transfer

The quantities of air required in conventional combustion also facilitate the pneumatic transportation of the pulverised fuel (PF) from the mills to the burner front and convey sensible heat to the mill for coal drying.

Although the inert components of air assist with the above issues, they also contribute to the overall dry gas thermal loss from the boiler plant. The nitrogen is heated in the combustion process and a proportion of that energy is lost to the stack.

The oxyfuel process requires the removal of nitrogen prior to combustion taking place using an air separation process. The resultant oxygen has a purity of typically >95% v/v, and is diluted back towards conventional oxygen concentrations using recycled flue gas in order to maintain combustion characteristics and temperatures similar to conventional air firing. If pure oxygen was used in the combustion zone without any dilution the resultant temperatures would be excessive and the consequent heat fluxes would far exceed the capabilities of a conventional water tube furnace arrangement. The recycled flue gas is taken from an appropriate location in the downstream gas ducting. Including flue gas recycle (FGR) in the combustion process also ensures that the flue gas flow rate passing through the convective banks achieves similar convective heat transfer performance to conventional air-fired derived flue gas.

The flue gas derived from the oxyfuel combustion process is composed mostly of carbon dioxide and water vapour due to the exclusion of the inerts in the air separation process. The benefit of the oxyfuel process is that the flue gas arising can be directly compressed to remove the water vapour and capture the carbon dioxide leaving only a small quantity of 'inert' gas to be vented to atmosphere. The carbon dioxide can be further compressed and purified (if necessary) to allow export to long term geological storage sites. Figure 1 presents the comparison between conventional air and oxyfuel combustion on a utility boiler.

4. THE CLEAN COMBUSTION TEST FACILITY

4.1. Layout Prior to Oxyfuel Upgrade

The Clean Combustion Test Facility (CCTF) is located at Doosan Babcock's Renfrew site in Scotland. This is one of the largest and most modern single burner test rigs in the world and is designed for the development and demonstration of burners firing coal, oil, gas or other fuels up to 90MW_t capacity.

Figure 2 presents a schematic view of the test facility while Figure 3 shows the windbox and furnace of the CCTF prior to its upgrading to oxyfuel-firing. The 90MW_t furnace is the principal component of the CCTF. It consists of a horizontal, water-jacketed combustion chamber with an internal length of 17m from the test burner (front wall) to the furnace exit plane. The furnace is approximately square in cross section with dimensions of 5.5m wide and 5.5m high. The burner windbox is fitted at the front end of the furnace and is capable of adjustment to accommodate burners of different dimensional size. The floor, walls and roof of the furnace are formed from a series of interlinked water tanks (modules) that operate at near ambient pressure.

Furnace cooling is effected by evaporation of water from the tanks, which are linked together by special seals that provide both sealing and differential thermal expansion capability between adjacent furnace sections; a total of seven modules make up the furnace length. Internally, the furnace surfaces are partly refractory lined and insulated to provide a thermal environment that is similar to that existing in commercial utility plant. As the CCTF is designed for a large range of burner types and sizes it is occasionally required that the degree of thermal insulation is modified. The hot surface refractory materials are composed of a combination high temperature firebrick and mouldable refractory.

The burner fires horizontally along the axis of the furnace. The burner entry to the furnace is usually a combination of a stainless steel quarl/throat, manufactured to the geometry required by the burner under test, surrounded by mouldable refractory. This ensures maximum flexibility for the range of burners. A general view of the inside of the furnace looking towards the burner is presented in Figure 4.

Coal is brought to the facility in pulverised form by road tanker. The primary air is pre-heated in a direct contact natural gas-fired air heater and can be raised to approximately 150°C maximum (depending on flow rate), though 70–90°C is typical for bituminous coal to replicate plant mill outlet conditions.

The combustion air to the test burner windbox is supplied by a forced draught fan, via a separate direct contact, natural gas fired air heater in which its temperature can be raised to a maximum of 320°C with a value of 250°C being more typical at the windbox. The oxygen content of the vitiated air steam from the air heater is restored to the equivalent of normal air by injection of vaporised oxygen from an adjacent cryogenic storage facility.

The CCTF has the ability to test two-stage combustion (TSC) burners at realistic plant conditions. The system has been designed for testing deep staged burners down to a primary zone stoichiometry of 0.75 by supplying TSC air through overfire air (OFA) ports. The OFA ports are located in pairs 1m above the centreline of the furnace. Figure 5 illustrates the three locations of OFA injection, each comprising of two ports in opposed-firing configuration angled towards the centreline of the furnace. The first location is in module 4, the second in module 5 and the third in module 6.

On exiting the furnace, the flue gases (nominally at a temperature of 800–1100°C depending on unit test load) pass through a convective heat exchange tube bank (comprising evaporative and superheat surfaces) and economiser. The flue gas temperature is approximately 220°C at the economiser outlet. At this point flue gas samples are extracted for the determination of gas species concentrations (normally NO_x, SO₂, CO and O₂ when air firing). In addition, ash is sampled from the flue gases for subsequent determination of carbon content. Steam generated in the heat exchanger is exhausted to atmosphere through a silencer.

After the economiser, the flue gas passes through a multi-cyclone grit arrestor system and an induced draught fan prior to being exhausted through the stack. The grit arrestor system consists of twelve cyclones in two parallel banks. The number of active cyclones can be adjusted depending on the operating thermal load of the CCTF. Each cyclone has a surge bin with a rotary lock valve to prevent re-entrainment of finer material. The fly ash collected by the cyclones is discharged to an ash bin using a blower via a separate closed circuit system.

A series of wall penetrations is located along each sidewall of the CCTF furnace on a horizontal plane that passes through the centreline of the test burner. These

penetration ports can be utilised for flame visualisation/video image recording and insertion of water-cooled probes for the determination of the velocity, temperature and chemical species (NO_x , CO, O_2 , CIA etc.) within the flame. Probe traversing equipment is fitted on one side of the furnace.

4.2. Modifications for Oxyfuel Combustion

The schematic arrangement of the CCTF following the modifications to allow oxyfuel combustion is presented in Figure 6. This upgrade included the addition of the following systems:

- FGR supply

The FGR supply system was installed to recycle part of the flue gas from the grit arrestor back to the burner. The recycled flue gas is split into three streams: TFGR (Transport FGR) which conveys the coal from the feeder to the burner in a dense phase system; PFGR (Primary FGR) which mixes with the TFGR immediately upstream of the burner entry with the combined stream replicating the conditions at the pulverising mill outlet; and SFGR (Secondary FGR) which is supplied to the windbox. New fans were installed for the PFGR and SFGR streams while the existing transport blower was replaced by a new unit. If required, two-stage oxyfuel combustion tests can also be carried out via a new duct from the SFGR fan outlet to the OFA ports. The existing multicyclone bypass air duct was modified to supply dilution air to the stack inlet and thereby reduce the stack CO_2 concentration to a level similar to air firing.

- Oxygen supply

Oxygen is supplied from three liquid oxygen storage tanks. Eight vaporisers convert the liquid oxygen into gaseous oxygen which is then injected into the PFGR and SFGR lines via an oxygen control skid. The system has safety shut off valves to trip the oxygen flow when the oxygen content in the PFGR and SFGR lines exceed safety limits or in the event of a main flame failure. All equipment was supplied by Air Products PLC.

- PFGR and TFGR cooling

The moisture in the PFGR and TFGR streams needs to be removed before pf is introduced. PFGR and TFGR cooling columns have therefore been installed for moisture removal, which occurs via condensation when the gas temperature is reduced to below the saturation temperature. These cooling columns operate using a closed circuit cooling water system; the water temperature is maintained by a two cell cooling tower.

- PFGR and TFGR heating

An electric heater is used to increase the temperature of the TFGR exiting the cooler so that the mixed stream of TFGR and pulverised fuel is maintained at ca. 10°C above the acid dew point. Steam from the CCTF waste heat boiler is used in a steam heater to increase the PFGR stream temperature and thereby prevent condensation when this stream is mixed with the dense phase stream of TFGR and pulverised fuel.

- Control room and SCADA

The original control room was situated below ground level which was not acceptable for oxyfuel operation due to the potential of risk of CO₂ accumulating in low-lying areas. A new control room with two exit routes was therefore installed at an elevated location. During the oxyfuel retrofit the existing Supervisory Control and Data Acquisition (SCADA) system was also upgraded to include controls for the additional hardware that was installed.

Figure 7 shows the firing floor, windbox and furnace of the CCTF after the facility was upgraded to oxyfuel firing.

4.3. Hazard and Operability (HAZOP) Study

4.3.1. Hazard Identification

A HAZOP study was completed during the DTI Technology Programme project TPC/00/00404/00/00 *OxyCoal UK Phase 1: Fundamentals and Underpinning Technologies* by using available Front End Engineering Design (FEED) data. With this study as the base, a more comprehensive HAZOP was later completed during the OxyCoal 2 project on completion of the detail design stage. The main potential hazards of the process that were identified are as follows:

- High concentrations of carbon dioxide

Conventional fossil fuel air firing produces a flue gas carbon dioxide concentration of 16–19% v/v (dry). However, the absence of nitrogen in oxyfuel flue gas increases the carbon dioxide concentration to potentially over 80% v/v (dry). Carbon dioxide is a toxic substance and is capable of causing serious harm to operators and other personnel in the vicinity. Therefore the time weighted average limit for carbon dioxide exposure is 0.5% (5000 ppm) and the short term exposure limit is 1.5% (15000 ppm)^[1]. Consequently, while carbon dioxide is potentially harmful at air firing conditions, the risk is increased during oxyfuel operation. This risk was minimised by taking the steps discussed in Section 4.3.2.

- High concentrations of oxygen in combustion ducts

Large quantities of oxygen at >95% purity will be used during oxyfuel operation thus increasing the hazard potential. In specifying and designing the oxygen supply system assistance was therefore obtained from Air Products PLC, a recognised expert in oxygen supply.

- Environmental Impact

The environmental impact of the plant under oxyfuel conditions is subject to requirements specified by Scottish Environment Protection Agency (SEPA). As the FGR cooling system has direct contact coolers, the acidic components in the flue gas accumulate in the cooling water. Steps were therefore taken to inhibit the release of effluent to the environment.

- Staff competency

The complexity of the oxyfuel firing introduces the requirement for higher levels of operator awareness and interaction than conventional coal/air firing. However, this feature of oxyfuel firing is probably at its peak in the initial test work stages where

the acceptable and non acceptable zones of operation and boundaries are being explored and defined and a greater use of manual control is generally adopted. Once the extent of controllability has been defined it may be possible to reduce the complexity but it is likely that increased operator training/assessment will remain as a feature of oxyfuel firing.

4.3.2. Designing out the Hazards

A number of actions, resulting from the HAZOP, required changes to the design of either the proposed oxyfuel system or to the existing test facility plant. The issues that were raised which may also relate to industry are listed below:

- **Reducing the risk of high concentration of CO₂ in leaking flue gas:**
 - FGR fans located as close as possible to burner front to minimise duct lengths under positive pressure
 - FGR duct routed external to the facility's buildings as much as possible
 - Air tight furnace viewing ports
 - Control room located in a zone that is away from possible carbon dioxide accumulation
 - CO₂ monitoring system with individual sensors and alarms installed across the plant
 - Compulsory use of personnel CO₂ monitors
- **Oxygen safety:**
 - FGR ductwork downstream of the oxygen injection system will be stainless steel
 - The oxygen delivery system is designed by recognised experts (Air Products PLC)
 - Quick response oxygen analysers with back-up systems are in place to trip the oxygen injection if the oxygen concentration in FGR lines exceed pre-set high levels.
 - Operating manuals for the oxygen delivery system are prepared by recognised experts (Air Products PLC)
 - Oxygen training to be provided by recognised experts (Air Products PLC)
- **Operation / Control:**
 - New safety interlocks linking new equipment to existing burner management system
 - Work instructions for the facility were updated to include the oxyfuel retrofit.

5. OXYCOAL™ BURNER

The first generation of oxyfuel burners will most likely be based on current low NO_x air-fired burner technology in order to ensure compatibility with existing plant for retrofit purposes. Additionally, a uniform 'simulated air' flue gas composition and a design recycle rate based on the consideration of radiant and convective heat transfer being theoretically similar to air firing, is the first logical operating point. With these points in mind, a 40MW_t OxyCoal™ burner was designed to best exploit a range of potential operating conditions for both Oxyfuel and air firing.

For oxyfuel operation the volumetric flow rate and molar oxygen content of the primary gas is maintained as per air firing. The design overall stoichiometric ratio is 1.16. The design FGR flow rate was selected to maintain radiant and convective heat transfer characteristics comparable to air firing.

Figure 8 presents a schematic illustration of the OxyCoal™ burner while Figure 9 shows this burner being installed on the CCTF.

6. BURNER MODELLING

Prior to testing, Computational Fluid Dynamics (CFD) modelling was undertaken to support the burner design process. The CFD work completed during the OxyCoal 2 project was a continuation of the modelling carried out in the DTI Technology Programme project TPC/00/00404/00/00. The CFD model of the 40MW_t OxyCoal™ burner extends from the windbox and primary gas inlets to the outlet of the CCTF furnace, and consists of 3.6 million cells. An image of the modelled geometry is shown in Figure 10. Two design operating scenarios were considered for this burner arrangement:

1. Air Firing
2. Oxyfuel Firing

Figure 11 shows the predicted gas temperature profiles in the furnace. Although Furnace Exit Gas Temperature (FEGT) is predicted to be broadly similar under oxyfuel and air firing combustion, the peak temperature is predicted to be somewhat higher.

The flame is predicted to be well rooted to the flame holder. It is also seen that oxyfuel firing is predicted to lead to a slightly narrower flame shape. This may be due to the reduced momentum resulting from the lower volumetric flow rate to the windbox when operating in oxyfuel mode, arising from the higher density of CO₂ compared to N₂ (1.8 kg/m³ vs. 1.14 kg/m³ at 25°C).

Clearly seen in Figure 12, in-flame CO concentrations are also predicted to be much higher under oxyfuel firing; this result agrees with the findings of a number of experimental studies^[2, 3]. At the furnace exit the CO emissions are comparable for air- and oxyfuel-firing.

7. TEST FACILITY COMMISSIONING

The OxyCoal™ burner is mounted in a windbox which supplies either combustion air or secondary FGR to the burner outer annuli. Combustion air enters the windbox perpendicular from the right side wall, looking at the front of the windbox/burner back plate, and the FGR enters perpendicular from the opposing wall (see Figure 6).

Before any testing of the burner could commence, the existing and new equipment related to the oxyfuel modifications was commissioned.

Cold commissioning comprised of circuit tracing, wiring checks and functional checks of individual systems.

Hot commissioning was undertaken as follows: firstly it was required to prove that the test facility was still capable of operating under air firing operation. These tests were successful and gave us the opportunity to characterise the OxyCoal™ burner, furnace and boiler performance in air firing mode for later comparison to oxyfuel firing mode. Figure 13(a) shows a typical air-firing flame.

Following this it was necessary to prove the test facility in oxyfuel oil firing operation. The tests successfully showed the transition from oil firing on air to oil firing on oxyfuel, and that a stable oxyfuel oil flame is achievable.

Finally it was necessary to prove the test facility under OxyCoal™ operation. The experience gained during oxyfuel testing on Doosan Babcock's 160kW_t Emissions Reduction Test Facility (ERTF) for the DTI Technology Programme project TPC/00/00404/00/00 proved invaluable for the 40MW_t OxyCoal™ testing. The OxyCoal 2 tests demonstrated that safe transition from air firing to oxyfuel operation is achievable, and that a stable OxyCoal™ flame can be maintained. Figure 13(b) shows the 40MW_t OxyCoal™ flame. This flame is visually practically indistinguishable from the flame obtained during air firing (Figure 13(a)), though it is noted that the OxyCoal™ flame appears to be slightly narrower than that obtained for air firing, consistent with the CFD modelling undertaken during the design phase of OxyCoal 2.

The systems required for operating the CCTF on both air and oxyfuel coal firing modes were successfully commissioned in July 2009.

8. 40MW_T OXYCOAL™ BURNER TESTING

The full-scale (40MW_t) OxyCoal™ burner was tested during the period August 2009 to April 2010.

8.1. Test Plan

The test programme was undertaken in three parts. Firstly the isothermal performance of the burner was characterised, after which the ability of the burner to operate safely under oxyfuel conditions was demonstrated, before finally undertaking parametric testing.

8.1.1. Isothermal Tests

Isothermal testing was undertaken to investigate the swirl number and pressure drop (k-factor) characteristics of the secondary and tertiary streams within the burner (see Figure 8).

8.1.2. Burner Proving

Combustion tests were undertaken to prove the full-scale 40MW_t OxyCoal™ burner firing bituminous coal in both air and Oxyfuel firing operation on the following basis:

a) Flame Stability

Ignition should be within the burner throat/quarl zone without the use of support fuel (e.g. oil).

b) Control / Operability

Investigate the burner's operational envelope with respect to start-up, shutdown, turndown and transition between air and oxyfuel firing.

8.1.3. Parametric Tests

Testing to characterise and investigate the achievable performance of the full-scale 40MW_t OxyCoal™ burner firing bituminous coal in both air and oxyfuel firing operation on the following basis:

a) Combustion

Determine characteristic levels of NO_x, CO₂, SO₂, and Carbon in Ash within the burner's stable combustion operating range.

b) Thermal

Determine test facility thermal performance in terms of heat release and absorption.

8.2. Coals

At the start of testing the reference coal, supplied by UK Coal as their contribution to the project, was Kellingley. Kellingley coal is widely used in UK power stations, including Ferrybridge and Drax. Additionally Kellingley coal has been the reference coal on the CCTF for a number of years.

However, during the course of the project, geological problems led to an interruption in the supply of Kellingley coal. El Cerrejón coal, from Colombia, is a widely available world traded coal, and was used in place of Kellingley. It was subsequently found that the pulverised coal feed was steadier with El Cerrejón coal in the CCTF, and as a result this was used for the remainder of the test programme.

Table 1 shows typical fuel analyses for each of the coals used.

8.3. Isothermal Tests

Isothermal testing of the OxyCoal™ burner was undertaken at a variety of air flows, swirler positions and damper positions to investigate the burner's aerodynamics in terms of swirl number and pressure drop (k-factor) characteristics. Both measured swirl numbers and pressure drop are as expected. Velocity profiles were measured and provided data to support CFD modelling activities (e.g. to define inlet boundary conditions for a furnace model).

Figures 14 and 15 show typical data obtained during the isothermal tests.

8.4. OxyCoal™ Combustion: Burner Proving

8.4.1. Plant Operability

Three air to oxyfuel transition methods were investigated.

- Transition from oxyfuel oil to OxyCoal™ combustion

This is the preferred transition method on the CCTF. Starting with air-firing oil combustion a switch is made to oil oxyfuel-firing (secondary air to SFGR) followed by the introduction of coal with primary air, increase in coal flow with reductions in oil until coal is at full load and oil support off, and then a switch from primary air to PFGR. This method of transition on the test facility was found to be reasonably quick to complete and also tolerant to fairly large fluctuations in fuel flow without affecting the flame stability. In this way the amount of OxyCoal™ test time was maximised.

- Transition from air-firing, starting with SFGR stream, to OxyCoal™

This approach starts with air-firing coal combustion (primary and secondary air) with a low level of oil support at reduced load. The first change is from secondary air to SFGR followed by increases in coal flow with corresponding reductions in oil flow until coal is at full load and oil support off, and finally by changing the primary air to PFGR. With this method it was found that more time was required to complete the transition as changes in coal flow during the load raising had an effect on economiser outlet oxygen and therefore SFGR oxygen concentration. As a result smaller and slower increments in coal load were required, this utilises more test coal and therefore reduces the OxyCoal™ test period available.

- Transition from air, starting with PFGR stream, to OxyCoal™

This approach also starts with reduced load air-firing coal combustion (primary and secondary air) with a low level of oil support. This time the first step is to change from primary air to PFGR. It is followed by increases in coal flow with reductions in oil until coal is at full load and oil support off. Finally the secondary air is changed to SFGR. This method also exhibits a feedback from the coal flow increments on the oxygen content of the recycled flue gas and therefore the transition to OxyCoal™ operation must be carried out more slowly.

Although a preferred method has been selected for the test facility to maximise the available OxyCoal™ test time as described above, nevertheless all three of the above methods have been demonstrated and are perceived to be applicable to oxyfuel boiler plant. Greater operator awareness was required during the transition period to OxyCoal™ operation due fan interactions (PFGR and SFGR) and to ensure FGR flows were in the forward direction prior to starting oxygen injection into each FGR line.

8.4.2. Air Ingress

An investigation on the location of air ingress into the oxyfuel combustion system was undertaken as the first results gave a CO₂ concentration of around 50% v/v dry when at full load OxyCoal™ operation.

The oxygen survey identified the main leakage paths, and subsequent air ingress minimisation tests resulted in a CO₂ concentration of around 85% v/v dry when at full load OxyCoal™ operation. For the CCTF the largest contribution to air in-leakage was via the windbox damper and therefore balancing pressures in the draught plant minimised this ingress. A utility plant on the other hand may have other routes of air in-leakage (e.g. furnace, boiler, economiser or particulate collector) which will require different control measures.

8.4.3. Flame Stability

Flame stability during commissioning and early stages of testing was observed to be variable which in some cases resulted in the oxyfuel flame moving off the burner and tripping due to loss of flame monitor signal. This was attributed to a combination of first time operation of oxyfuel at this scale, learning operational limits of oxyfuel equipment and operating the facility at higher FGR rates (>80%). After more oxyfuel operational experience was gained the flame stability was improved to the point that the air-firing and oxyfuel-firing flames were similar in shape and both were well rooted to the burner flameholder. The OxyCoal™ burner was demonstrated to deliver a stable flame for both air- and oxyfuel-firing across a wide operating envelope. Figure 13 shows a comparison of typical flames.

8.4.4. Turndown

The firing load of the OxyCoal™ burner was turned down in discrete stages from 100% load to ca. 40% load. For each load reduction increment first the coal flow (thermal input) was reduced, followed by the PFGR flow and finally the SFGR to restore the excess oxygen level. The PFGR turndown was typical of a normal E-mill installation (i.e. the flow was decreased linearly from 100% at mill full load to 70% of the full load value at 50% burner load using a linear interpolation between these two points for intermediate load settings). Steady state part load tests were performed at 32MW_t, 24MW_t, 20MW_t and 15MW_t (approximately 80%, 60%, 50% and 38% burner load, respectively). As expected, flame length reduces as load is reduced. A stable, rooted flame was maintained for all loads down to 40%, as illustrated in Figure 16. This turndown performance is comparable to Doosan Babcock's commercially available air firing low NO_x axial swirl burners currently operating around the world.

8.5. OxyCoal™ Combustion: Parametric Testing

Following successful completion of the burner proving tests, a test programme was undertaken to establish the operational envelope of the OxyCoal™ burner, investigating the effects of FGR rate, SFGR oxygen concentration, PFGR oxygen concentration and burner stoichiometric ratio on flame stability, heat release, gas species (NO_x, CO, SO₂, etc.) and burnout.

Almost 100 parametric tests were completed, as shown in Figure 17, with the results described in the following sections.

8.5.1. CO₂ Concentration

Carbon Dioxide (CO₂) levels for air firing are typically 16% v/v dry. During the oxyfuel firing tests CO₂ measurements at the economiser exit of greater than 75% v/v dry were achieved. However, when reviewing the measured CO₂ results with calculated levels from the system mass balance it was found that measured values above 75% v/v dry were higher than expected. It is believed that the accuracy of the CO₂ gas analysis equipment was affected by the oxyfuel process when CO₂ levels were

greater than 75% v/v dry. The problem with the CO₂ analyser was confirmed by checking the measurements against calibration gases containing 70%, 85% and 100% CO₂. Therefore the raw CO₂ measurements at the economiser exit, which were above 75%, were corrected using independent measurements and the system mass balance.

The CO₂ gas analysers were found to return to the certified accuracy when they were taken off-line for a few days. Since oxyfuel flue gas seems to affect the accuracy of the measurement, further investigation on measuring high CO₂ concentrations in oxyfuel combustion systems is therefore required.

8.5.2. NO_x Performance

When Nitrogen Oxide (NO_x) concentrations are expressed as ppm, oxyfuel-firing produces approximately 3 times the concentration of air-firing at comparable stoichiometry (see Figure 18(a)). The higher concentration of NO_x for oxyfuel-firing can be mostly attributed to the removal of inert N₂ from the system (which has a dilution effect for air-firing). It is therefore more appropriate to compare the production rate of NO_x in terms of mg/MJ. When NO_x is presented in this manner, as shown in Figure 18(b), oxyfuel firing generates approximately half the NO_x (mg/MJ) compared to air firing at the same burner stoichiometry.

8.5.3. Production of SO_x

When Sulphur Dioxide (SO₂) concentrations are expressed as ppm, oxyfuel firing produces approximately 3 times the concentrations of air-firing. Again, it is more appropriate to present SO₂ concentrations in the flue gas entering the CO₂ capture and compression plant as mg/MJ. When SO₂ concentrations are presented in this manner, as shown in Figure 19, oxyfuel-firing generates approximately 25% lower SO₂ concentrations (mg/MJ) than air-firing. From this result it can be deduced that SO₂ is being removed from the system. Two possibilities are postulated:

- Dissolution of the SO₂ in the direct contact cooling columns.
- Absorption of SO₂ on the fly ash.

8.5.4. Combustion Efficiency

Carbon Monoxide (CO) measurements were recorded during both air-firing and oxyfuel-firing. Comparison of the CO results shows that the average concentrations measured for each of the different firing methods are similar, typically below 200ppm for air and oxyfuel firing. Figure 20 compares air- and oxyfuel-firing CO levels in mg/MJ. Both sets of data show the expected trend of rapidly increasing CO as the burner stoichiometric ratio decreases below unity, i.e. causing incomplete combustion.

Solid sampling was undertaken at the economiser outlet during both air firing and oxyfuel firing, and the samples analysed for carbon-in-ash (CIA). These CIA values were then converted to an unburned loss value (% GCV). Figure 21 shows that the unburned loss is comparable for air and oxyfuel firing; typically the unburned loss was below 1% GCV in the CCTF.

It is anticipated that both CO and unburnt loss will be lower on a full scale utility boiler furnace as the CCTF is restricted by short burn-out zone residence time.

8.5.5. Heat Flux

During both air firing and oxyfuel firing testing total absorbed heat flux measurements were taken at 10 locations along the centreline of the furnace. Figure 22 compares typical air and oxyfuel heat flux results. Comparison of these results show that the oxyfuel flame radiates less heat to the walls in the first half of the furnace when compared to air-firing, though similar heat fluxes were observed in the last half of the furnace. The differences between heat flux profiles can be explained by a combination of the mass flow through the burner and dust concentration.

8.5.6. Boiler Thermal Performance

The CCTF waste heat boiler's thermal performance for air-firing and oxyfuel-firing was assessed using the 40MW_t OxyCoal™ test data. It was found that the bank thermal performance was predictable using design software, taking into account factors such as the differences in flue gas composition for air and oxyfuel combustion.

8.5.7. Flame Observations

Flame imaging equipment on the furnace side wall was used to constantly monitor the flame root location and general flame shape during both air firing and oxyfuel firing operation. Viewing ports located along the furnace side wall were also used for visual checks of flame length. The OxyCoal™ burner at full load (40MW_t) has the same flame length for both air and oxyfuel firing. The flames produced during steady state conditions were well rooted to the flameholder and similar in shape across a wide range of operating conditions for both air and oxyfuel firing. Figure 13 presents images of coal flames at 40MW_t load for air firing and OxyCoal™ firing respectively. Figure 16 shows a selection of flame images during turndown. At low load a change in flame shape can be seen, with increased 'necking' of the flame shape close to the burner face (see Figure 16(b) to (d)). This is due to a greater proportion of oxygen being delivered by the primary stream at low load due to the requirement to mimic the operation of the coal pulverising mill.

The testing also showed that no special flame monitoring equipment is required to be used with oxyfuel. The same flame monitoring equipment was used on the OxyCoal™ burner throughout the air and oxyfuel trials with similar and acceptable scanner outputs.

9. ANTICIPATED PERFORMANCE OF UTILITY PLANT

9.1. Air-Firing versus Oxyfuel-Firing

During a recent European Union funded project (RFCS OxyMod, contract number RFCR-CT-2005-00006) Doosan Babcock analysed the impact of oxyfuel-firing on utility boiler thermal performance. The modelling approach included the assumption that the flame envelope and heat release profile is similar for air- and oxyfuel-firing. The OxyCoal 2 tests have demonstrated that both air firing and OxyCoal™ operation have similar flame lengths and the validity of the assumptions underlying the OxyMod simulations. The modelling results can therefore be used as an indication of the thermal performance of a supercritical boiler operating in both firing modes.

Summaries of the modelling outcomes are presented in Tables 2 and 3. The results indicate that introducing oxyfuel to the boiler has a slight impact on thermal performance; the differences, however, were not excessive. Oxyfuel operation had a

higher arch level gas temperature. As a result of higher gas temperatures in the lower furnace, there were higher incident heat fluxes to the furnace walls. Total furnace wall heat absorption also increased. Platen heat absorption was also increased and the furnace exit gas temperature (FEGT) for oxyfuel firing was marginally higher. Downstream the impact of oxyfuel firing diminished; the model outlet temperature was lower with this firing condition. The magnitude of the changes was less than the daily variation arising from ash deposition on the heat transfer surfaces.

9.2. Implications of Test Results for Future Oxyfuel Plant

The full scale 40MW_t OxyCoal™ tests proved that the stability of the oxyfuel flame was comparable to air firing. Furthermore, analysis of the CCTF waste heat boiler's thermal performance using empirical data from these tests demonstrated that existing Doosan Babcock design methods could be appropriately applied to predict the heat transfer during oxyfuel-firing. Future OxyCoal™ utility boilers can therefore be designed using the established design methods by taking into account the variation in heat transfer due to the change in gas composition.

The OxyCoal™ tests on the CCTF demonstrated the need to manage the interaction between the different fans in the plant when transitioning from air firing to oxyfuel operation. Oxygen injection to each FGR line should be started only after confirming the gas flow was in the required direction. Although the operating characteristics were rig specific, they could also be applicable to future oxyfuel utility plants. A greater operator awareness and control will therefore be a feature of oxyfuel firing.

OxyCoal™ flue gas has a higher concentration of SO₂ (ppm) than air firing. In order to ensure that an oxyfuel utility plant is no more susceptible to corrosion due to high SO₂ (and SO₃) and HCl concentrations (ppm), the flue gas needs to be cleaned before being recycled to the boiler plant. Thus, a flue gas desulphurisation plant would be required to ensure that the corrosive gas components in FGR line are no worse than that experienced with air-firing. A US DOE study has also suggested that oxyfuel plants will need FGD systems except when burning low sulphur coals^[4]. However earlier work by Doosan Babcock and Air Products showed that NO_x and SO₂ are virtually completely removed from the flue gas in the compression plant^[5]. Thus the overall emissions of NO_x and SO₂ to the environment are almost zero.

9.3. Economic Assessment

The OxyCoal 2 project demonstrated that the 40 MW_t OxyCoal™ burner can be used for air-firing or oxyfuel operation. Modelling of a supercritical boiler completed during the RFCS OxyMod project also indicated that the difference between oxyfuel and air firing was not excessive (refer section 9). Earlier techno-economic studies for oxyfuel operation^[4,6,7] assumed that if the correct recycle rate was maintained the boiler performance for oxyfuel operation would be similar to air firing. The OxyCoal™ test data now provide unequivocal support to verify this assumption.

These previous oxyfuel economic evaluations had considered scenarios with different options for oxyfuel operation at a number of utility markets. For example the DTI project 407 looked at the technical and economic feasibility of retrofitting UK coal-fired power plants with advanced supercritical boiler/turbine (ASC BT) technology and carbon dioxide capture^[6]. The BERR project 366^[7] investigated future CO₂ capture options for the Canadian Market, while the work completed for DOE NETL Contract Number DE-AC26-04NT41817 evaluated the economics of new build oxycombustion power plants for the US market^[4]. Although each market is different

and each study based the evaluation on a different financial year, they provide an indication of the likely increase in the cost of electricity for oxyfuel operation and the corresponding cost for avoided CO₂ emissions.

Tables 4 to 6 present summaries of the economic assessments from the above studies. Oxyfuel operation in general was found to reduce the net power plant efficiency by ca. 10 percentage points. The DTI project 407 suggested that ASC BT upgrade and oxyfuel retrofit to existing UK power plants would increase the cost of electricity (COE) by ca. 3 p/kWh relative to ASC BT upgrade^[6]. The BERR project 366 indicated that oxyfuel retrofit to future Canadian advanced supercritical plants would increase the COE by 4.7 CA ¢/kWh (2.1 p/kWh). This difference in the economics for oxyfuel retrofit on existing UK and future ASC Canadian power plants could be attributed to the cost of fuel, site specific conditions, project life, taxes etc.

The predicted COE for new build oxyfuel ASC Canadian plants was estimated to be 3.4 CA ¢/kWh (1.5 p/kWh) more than the cost for new build ASC Canadian power plants without CO₂ capture^[7]. According to the US NETL study, compared to new build power plants with no CO₂ capture, new build oxyfuel plants would increase the COE by ca. 3.2 - 3.8 US ¢/kWh (1.6 – 1.9 p/kWh)^[4].

The estimated cost for CO₂ capture and compression (excluding CO₂ transport and storage) was 45 – 47 £/tonne of CO₂ emissions avoided relative to ASC BT retrofit on UK power plants^[6]. For the Canadian market the cost to retrofit oxyfuel CO₂ capture was about CA \$67 (£30) per tonne of CO₂^[7]. On the other hand, the cost predictions for new build ASC Canadian oxyfuel power plants was CA \$48 (£22) per tonne of CO₂ emissions avoided, while for new supercritical and ultra supercritical US plants it was US \$37 - 43 (£19 - 21) per tonne of CO₂ emissions avoided^[4,7].

The above studies also estimated the costs for post combustion carbon dioxide capture (PCCC) which is an alternative method of carbon dioxide capture applicable to utility plants. As presented in Table 7, both PCCC and oxyfuel carbon dioxide capture have similar penalties on plant efficiency and costs for avoided CO₂ emissions.

A recent IEA report provides more details on other techno-economic studies for coal-fired power plants with oxyfuel CO₂ capture^[8].

10. CONCLUSIONS

- The CCTF was successfully converted to oxyfuel operation.
- A full scale 40MW_t OxyCoal™ burner was successfully demonstrated under both air and oxyfuel operation. Safe and stable operation was achieved across a wide operational envelope. Oxyfuel flame stability was comparable to air-firing experience.
- Safe and smooth transitions between air- and oxyfuel-firing were demonstrated; three different transition methodologies were proven.
- Turndown from full load to 40% load was demonstrated. Stable and well rooted flames were observed across the whole load range. Flame length decreases with decreasing load (as for air-firing).

- Combustion efficiency, as expressed by carbon-in-ash, unburned loss, and CO, is comparable for air- and oxyfuel-firing.
- Flame shape under air and oxyfuel conditions is similar. Under oxyfuel-firing the flame is slightly narrower than for air-firing, this is consistent with expectations based on CFD modelling undertaken during the burner design.
- NO_x generated by the combustion process is significantly lower under oxyfuel firing, by a factor of ca.2, when expressed as mg/MJ. Oxyfuel has the additional benefit of virtually eliminating NO_x emissions with almost all the NO_x being captured in the flue gas compression plant.
- SO₂ produced by the combustion process under oxyfuel firing conditions is lower than for air-firing; this is due to removal of SO₂ in the process (dissolution in the direct contact coolers and absorption on the fly ash). The SO₂ is likely to be captured completely by the CO₂ compression and cleaning plant, leading to no emissions to the environment.
- There are differences in the measured absorbed heat flux profiles observed for air and oxyfuel firing. These are explainable by differences in operating conditions and ash concentration.
- Realistic CO₂ levels in the combustion plant were achieved (in excess of 75% v/v dry, and up to 85% v/v dry).
- A number of practical lessons were learned
 - The need to verify measurements (via a system mass balance) to identify instrument issues (e.g. CO₂ analyser error at high CO₂ concentrations).
 - The ability to reduce air in-leakage by balancing pressures through the draught plant.
 - The impact of fan interactions during the transition between air- and oxyfuel-firing.
- All the project objectives were achieved.

11. IMPLICATIONS OF PROJECT RESULTS

A Gateway Review meeting was held in July 2010 to review the detailed results, conclusions of Phase 1 of the work, the project reports and the implications of the project results for future application of the technology. Consideration was also given to discuss follow on work, in particular the option in the DECC contract to continue the testing.

At the stage of the project proposal it was recognised that the results should be reviewed with the partners against three key criteria to judge whether or not oxyfuel firing would be of importance in determining the prospects for oxyfuel as a carbon-capture technology:

- Impact of any changes to flame shape or luminosity
- Plant operability
- Process economics

In fact the results of this project (see sections 8 and 9) are altogether positive with respect to these criteria:

- The flame shape and luminosity have been found to be quite similar and controllable such that no major furnace or boiler design changes would be required.
- The tests of a commercial scale 40MWt OxyCoal™ burner have successfully demonstrated burner operating performance in air and oxyfuel mode. The operating performance on the test facility was deemed satisfactory for commercial scale plant operational requirements.
- On process economics, the finding is that there is no significant change to the costs of the boiler, furnace, burners or combustion system for an oxyfuel firing plant compared to an air firing plant.

A further teleconference was held on 28 October^[9] to discuss options for the continuation of the project. It was concluded that continuation to further testing (Phase 2) would be very valuable. Participants expressed interest in Phase 2 including extended hours testing, additional types of coal, and design variations to the burner.

The increased confidence in oxyfuel is underpinned by the continuing interest of Doosan Babcock and the potential end users in the oxyfuel technology for carbon capture, both new build and retrofit:

Four of the industrial partners and the Universities are continuing their own oxyfuel work in parallel R+D, studies.

There are several possible applications to the UK competition for Demonstration projects (2-4).

Several of the partners are collaborating in underpinning R+D at the University of Leeds

In the USA, the DOE have recognised the importance of oxyfuel and funded (80%) a demonstration project (AEP's Meridosa plant, 200MWe) named Futuregen2. This replaces their previous plan to support an IGCC/Precombustion project.

In Korea, Doosan Babcock in conjunction with Doosan Heavy and KEPRI are executing a FEED study for an oxyfuel retrofit demonstration project (Youngdong, 100MWe).

In Germany, Vattenfall have reported more than 9000 hours of successful operation of their 30MWt Schwarze Pumpe oxyfuel power plant. Air Products have installed and commissioned a pilot oxyfuel Purification system^[10] for testing at Schwarze Pumpe in the next 12 months. Vattenfall have invited Doosan Babcock to demonstrate the OxyCoal™ burner at Schwarze Pumpe in 2011. In addition, Vattenfall are pursuing a full size (250MW) demonstration project at their Jämschwalde plant in Germany.

REFERENCES

- [1] Safety Data Sheet, Air Products
MSDS No. 300000000020 (2007)
- [2] B Goh
E.ON UK's pilot scale oxy-fuel combustion experiences: development, testing & modelling
3rd Meeting of the IEA GHG Oxy-Fuel Combustion Network
Yokohama, March 2008
- [3] S Hjærtstam, K Andersson and F Johnsson
Combustion characteristics of lignite-fired oxy-fuel flames
32nd International Conference on Coal Utilization & Fuel Systems
Clearwater, USA, June 2007
- [4] J L Haslbeck, J Black, N Kuehn, E Lewis, M D Rutkowski, M Woods and V Vaysman
Pulverized Coal Oxycombustion Power Plants
DOE/NETL Report No. 2007/1291, August 2008
- [5] V White, L Torrente-Murciano, D Sturgeon and D Chadwick
Purification of oxyfuel-derived CO₂
Energy Procedia 1: 399–406 (2009)
- [6] R S Panesar, M R Lord, S T Simpson, V White, J Gibbins and S Reddy
Coal-Fired Advanced Supercritical Retrofit with CO₂ Capture
Emerging Energy Technologies Project Report
TSB Contract No. C/08/00393/00/00, December 2007
- [7] B Xu, R A Stobbs, V White, R A Wall, J Gibbins, M Iijima and A MacKenzie
Future CO₂ Capture Technology Options for the Canadian Market
BERR Report No. COAL R309, March 2007
- [8] R M Davidson and S O Santos
Oxyfuel Combustion of Pulverised Coal
IEA Clean Coal Centre
Report No. CCC/168, June 2010
- [9] Teleconference was attended by Doosan Babcock, SSE, Vattenfall, E.ON, Scottish Power, DONG, Air Products, EDF, Drax, University of Nottingham and Imperial College
- [10] The Oxyfuel purification system was initially tested at Renfrew in the OxyCoal 1 project

LINKS TO PREVIOUS OXYFUEL PROJECTS

The information and experience gained from the following previously completed oxyfuel projects were useful in the successful completion of the OxyCoal 2 project:

- DTI Technology Programme project TPC/00/00404/00/00 *OxyCoal_UK Phase 1: Fundamentals and Underpinning Technologies*
 - The findings from this project were used as the basis for the OxyCoal 2 project.
 - Experience on testing oxyfuel at a 160kW_t scale later used for the 40MW_t OxyCoal™ testing.

- Initial CFD analysis of the OxyCoal™ burner was carried out during this project, and was later completed during OxyCoal 2.
- This project included a preliminary HAZOP for oxyfuel combustion at the CCTF. It was the foundation for the comprehensive HAZOP completed during OxyCoal 2.
- European Union project RFCS OxyMod (Contract number RFCR-CT-2005-00006)
 - The prediction of supercritical boiler performance for air firing and oxyfuel firing was used in Section 9.1 of this report.
- DTI project 407 *Coal-Fired Advanced Supercritical Retrofit with CO₂ Capture*
 - Information on the economics of oxyfuel operation used in Section 9.3 of this report.
- BERR project 366 *Future CO₂ Capture Technology Options for the Canadian Market*
 - Information on the economics of oxyfuel operation used in Section 9.3 of this report.

ACKNOWLEDGEMENTS

The authors gratefully acknowledge the grant funding provided by the UK Department of Energy and Climate Change (DECC) and the technical and financial contributions made by the project collaborators: University of Nottingham, Imperial College London, Scottish and Southern Energy PLC (Lead Sponsor), Air Products PLC, DONG Energy, Drax Power Limited, EDF Energy PLC, EON UK PLC, Scottish Power Limited, UK Coal and Vattenfall AB. The authors also wish to thank the members of Doosan Babcock's R&D department for their technical support throughout the OxyCoal 2 Project.

TABLES

COAL	Kellingley	El Cerrejón
Proximate (% as Rec'd)		
Moisture	4.0	4.7
Volatile Matter	29.6	36.7
Fixed Carbon	47.9	56.5
Ash	18.5	2.1
	100.0	100.0
GCV (MJ/kg as Rec'd)	26.05	31.85
Ultimate (% as Rec'd)		
Moisture	4.02	4.66
Carbon	63.31	77.24
Hydrogen	4.18	5.08
Sulphur	1.77	0.59
Chlorine	0.23	0.02
Nitrogen	1.31	1.58
Oxygen	6.68	8.73
Ash	18.50	2.10
	100.0	100.0
Size Grading		
DRY		
<0.300mm	99.4	99.9
<0.150mm	98.0	98.3
<0.075mm	77.4	79.4
WET		
<0.075mm	80.4	79.8
Fuel Ratio	1.62	1.54
Stoich. Air Ratio	8.51	10.28
Nitrogen (dry ash free)	1.69	1.69
Volatile Matter (dry ash free)	38.20	39.36
Volatile Matter (dry mineral matter free)	36.53	39.15

Table 1: Typical coal analysis for Kellingley and El Cerrejón coals.

	Oxyfuel- versus Air-Firing
Heat Inputs	
Chemical heat	1.7%
Heat in combustion 'air'	-13.9%
Heat in hopper flue gas	0%
Total heat input	- 0.2%
Heat Outputs	
Heat Absorptions	
Furnace wall	7.5%
Furnace roof	0%
Convective pass enclosure	0%
Convective pass roof	0%
Platen superheater	6.4%
Final superheater	5.5%
Pendant reheater	0%
Boiler screen	0%
Primary reheater	0%
Total heat absorption	5.5%
Heat in flue gas at model exit	-11.6%
Total heat output	- 0.2%

Table 2: Comparison of oxyfuel- and air-firing heat balance results from the OxyMod Project.

	Oxyfuel- versus Air-Firing
Arch	48°C
FEGT	5°C
Pendant reheater inlet	2°C
Boiler screen outlet	- 7°C
Model exit	- 12°C

Table 3: Comparison of oxyfuel- and air-firing gas temperatures from the OxyMod Project.

		Ratcliffe Power Station ASC BTR and oxyfuel retrofit	Drax Power Station ASC BTR and oxyfuel retrofit	West Burton Power Station ASC BTR and oxyfuel retrofit
Plant Performance				
Net Output	MW _e	448	476	452
Efficiency and Emissions				
Net Plant Efficiency	%, LHV	34.9%	34.1%	34.4%
Efficiency Penalty for CO ₂ Capture (relative to ASC BTR)	Percentage points based on LHV	10.0	9.9	10.1
CO ₂ emissions	g/kWh net	115	109	112
CO ₂ captured	g/kWh net	854	805	829
Economic Performance				
Cost of Electricity	p/kWh	5.38	5.08	5.56
Difference in Cost of Electricity (relative to ASC BTR)	p/kWh	2.88	2.71	3.04
Cost of CO ₂ Avoidance (relative to ASC BTR)	£/tonne CO ₂	45.1	43.4	47.4

Notes:

- All prices are based on 2005–2006 cost basis and a 25 year plant life

Table 4: Summary of oxyfuel combustion economics for the UK market, taken from Ref [6].

		ASC power plant without CO ₂ capture	ASC power plant with oxyfuel CO ₂ capture	ASC power plant with retrofitted oxyfuel CO ₂ capture
Plant Performance				
Net Output	MW _e	503	400	392
Efficiency and Emissions				
Net Plant Efficiency	%, LHV	45.6%	36.2%	35.5%
Efficiency Penalty for CO ₂ Capture (relative to ASC power plant)	Percentage points based on LHV	-	9.4	10.1
CO ₂ emissions	g/kWh net	790	80	90
CO ₂ captured	g/kWh net	-	720	810
Economic Performance				
Cost of Electricity	Canadian ¢/kWh (p/kWh)	6.48 (2.94)	9.86 (4.48)	11.17 (5.08)
Difference in Cost of Electricity (relative to ASC power plant)	Canadian ¢/kWh (p/kWh)	-	3.38 (1.54)	4.69 (2.14)
Cost of CO ₂ Avoidance (relative to ASC BTR)	Canadian\$/tonne of CO ₂ (£/tonne CO ₂)	-	47.76 (21.71)	66.76 (30.35)

Notes:

- All prices are based on 2006 cost basis and a 40 year project life
- Exchange rate: Canadian \$2.2 = £1.0

Table 5: Summary of oxyfuel combustion economics for the Canadian market. Data taken from Ref [7].

		SC power plant without CO ₂ capture	SC power plant with oxyfuel CO ₂ capture	USC power plant without CO ₂ capture	USC power plant with oxyfuel CO ₂ capture
Plant Performance					
Net Output	MW _e	550	550	550	550
Efficiency and Emissions					
Net Plant Efficiency	%, HHV	39.4%	29.3%	44.6%	33.0%
Efficiency Penalty for CO ₂ Capture (relative to plant without CO ₂ capture)	Percentage points based on HHV	-	10.1	-	11.6
CO ₂ emissions	lb/kWh net (g/kWh net)	1.763 (801)	0 (0)	1.558 (708)	(0)
CO ₂ captured	lb/kWh net (g/kWh net)	-	2.374 (1079)	-	2.104 (956)
Economic Performance					
Cost of Electricity	US ¢/kWh (p/kWh)	6.32 (3.16)	10.07 (5.03)	6.43 (3.21)	9.59 (4.78)
Difference in Cost of Electricity (relative to ASC power plant)	US ¢/kWh (p/kWh)	-	3.75 (1.87)	-	3.16 (1.57)
Cost of CO ₂ Captured (relative to plant without CO ₂ capture)	US \$/tonne of CO ₂ (£/tonne CO ₂)	-	31.6 (15.78)	-	30.1 (15.03)

Notes:

- 20 year levelised cost of electricity was calculated based on 2007 US dollars
- Exchange rate: US \$2.0 = £1.0

Table 6: Summary of oxyfuel combustion economics for the US market. Data taken from Ref [4].

	Retrofitting UK ASC plants ^(a)		Retrofitting ASC Canadian plants ^(b)		New Canadian ASC plant ^(b)		New US SC power plants ^(c)		New US USC power plants ^(c)	
	Oxyfuel	PCC	Oxyfuel	PCC	Oxyfuel	PCC	Oxyfuel	PCC	Oxyfuel	PCC
CO ₂ captured	88%	85%	91%	90%	92%	90%	100%	90%	100%	90%
Penalty on net plant efficiency	10% (LHV)	9% (LHV)	10% (LHV)	10% (LHV)	9% (LHV)	10% (LHV)	10% (HHV)	11% (HHV)	12% (HHV)	11% (HHV)
Increase in the cost of electricity ^(d)	2.88 p/kWh	2.26 p/kWh	4.67 ¢/kWh (2.12 p/kWh)	3.44 ¢/kWh (1.56 p/kWh)	3.38 ¢/kWh (1.54 p/kWh)	3.35 ¢/kWh (1.52 p/kWh)	3.75 ¢/kWh (1.87 p/kWh)	4.59 ¢/kWh (2.30 p/kWh)	3.16 ¢/kWh (1.58 p/kWh)	3.86 ¢/kWh (1.93 p/kWh)
Cost of CO ₂ avoided (per ton of CO ₂)	£45.3	£37.3	CA \$66.8 (£30.4)	CA \$50.0 (£22.7)	CA \$47.8 (£21.7)	CA \$48.8 (£22.2)	US \$31.6 ^(d) (£15.8)	US \$41.6 ^(d) (£20.8)	US \$30.1 ^(d) (£15.0)	US \$41.1 ^(d) (£20.6)

Notes:

- (a) Data from DTI project 407 ^[6]
(b) Data from DTI project 366 ^[7]
(c) Data from US DOE (NETL) study ^[4]
(d) Cost of CO₂ captured

Table 7: Comparison of Oxyfuel and Post Combustion Capture (PCC).

FIGURES

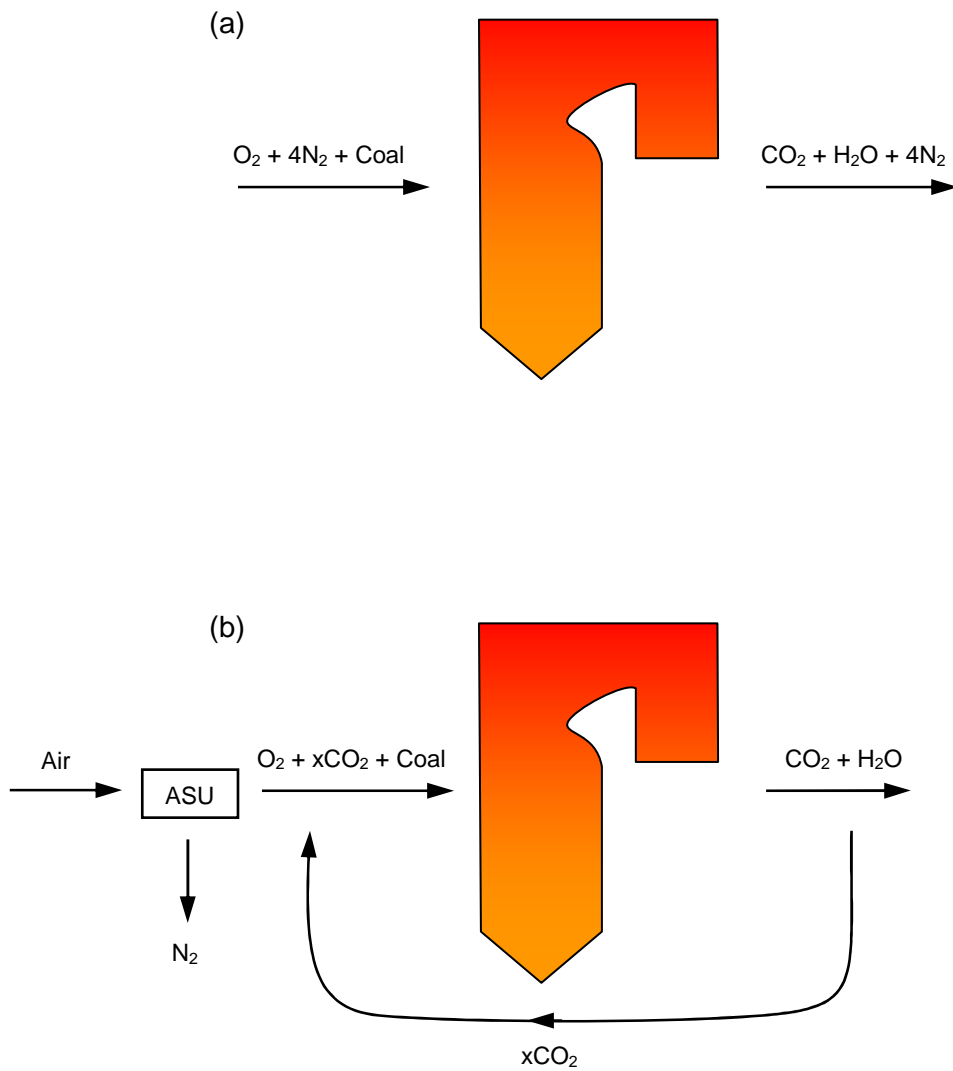

Figure 1: Schematic process diagrams: (a) air-firing, (b) oxyfuel-firing.

- | | | |
|-----------------------|----------------------------------|----------------------------|
| 1 Coal Hopper | 9 Secondary Air Heater | 17 Waste Heat Boiler |
| 2 Coal Feeding System | 10 Secondary Air Duct | 18 Superheated Steam Stack |
| 3 Transport Blower | 11 Two Stage Combustion Air Duct | 19 Economiser |
| 4 Transport Heater | 12 Dilution Air Duct | 20 Grit Arrestor |
| 5 Primary Air Fan | 13 Burner | 21 Induced Draught Fan |
| 6 Primary Air Heater | 14 Windbox | 22 Stack |
| 7 Primary Air Duct | 15 Furnace | |
| 8 Forced Draught Fan | 16 Furnace Steam Stack | |

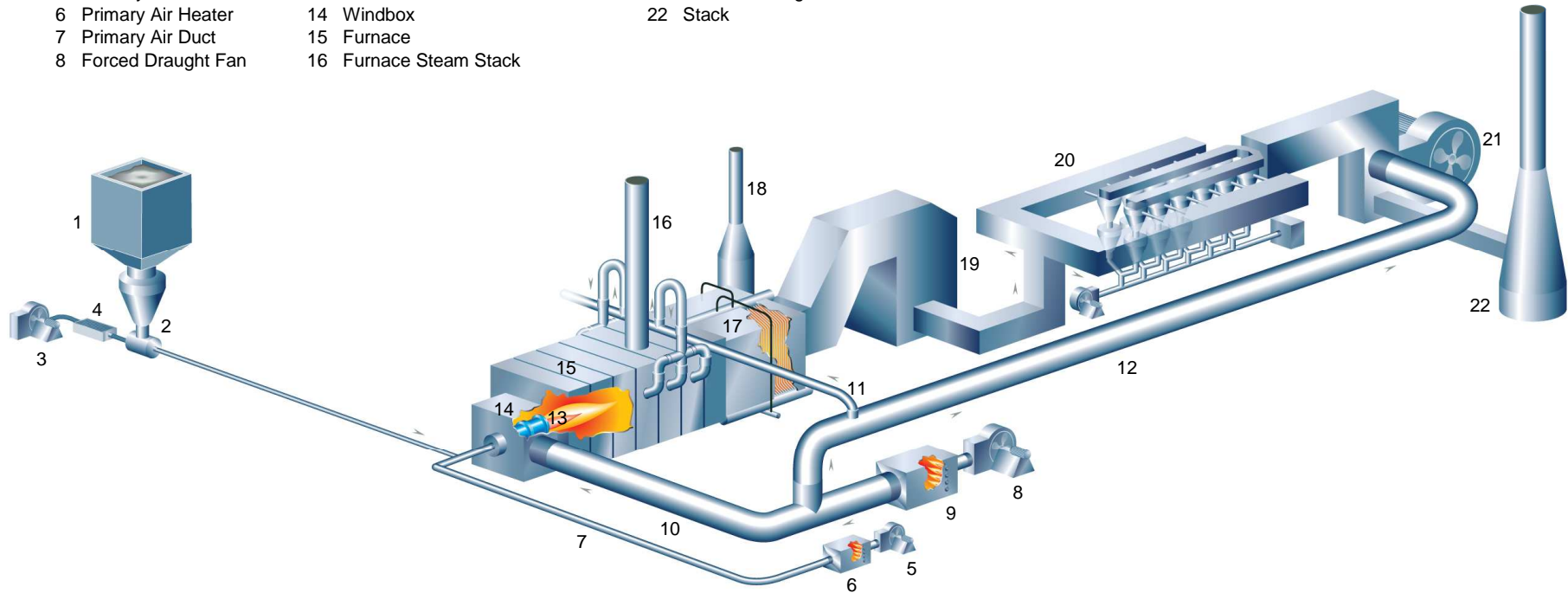

Figure 2: Layout of the Clean Combustion Test Facility (CCTF) before upgrade for oxyfuel combustion.



Figure 3: View of the burner gallery before upgrade for oxyfuel combustion.

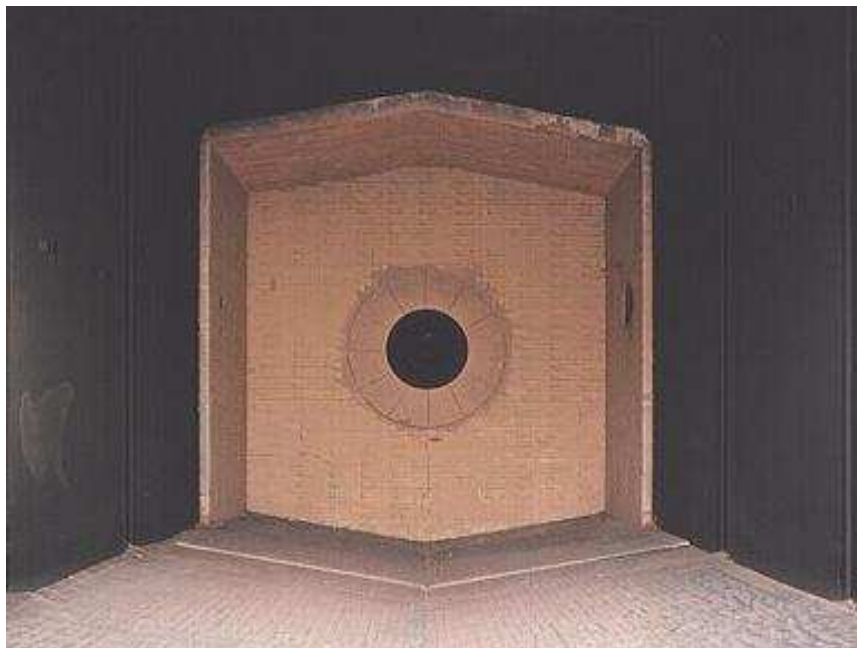

Figure 4: View inside the CCTF furnace.

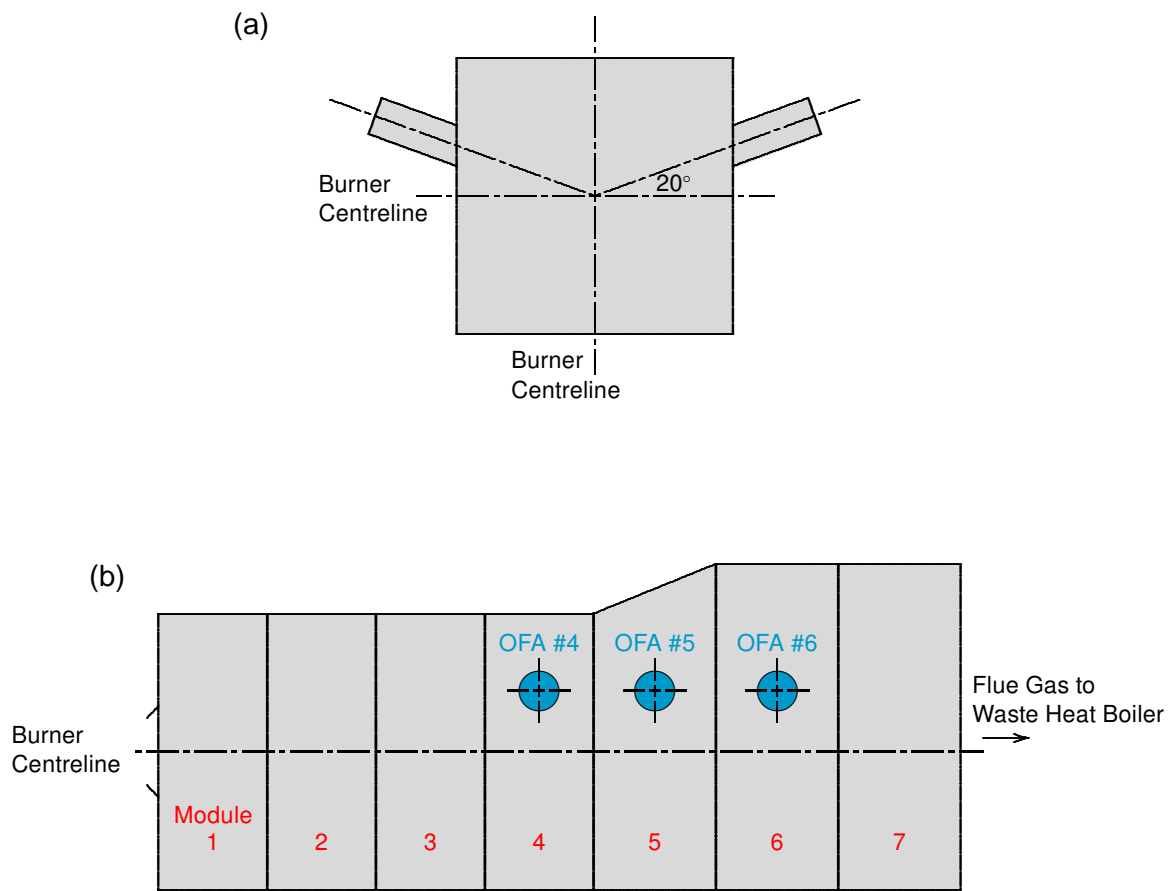

Figure 5: Position of overfire air (OFA) ports: (a) front view, (b) side view.

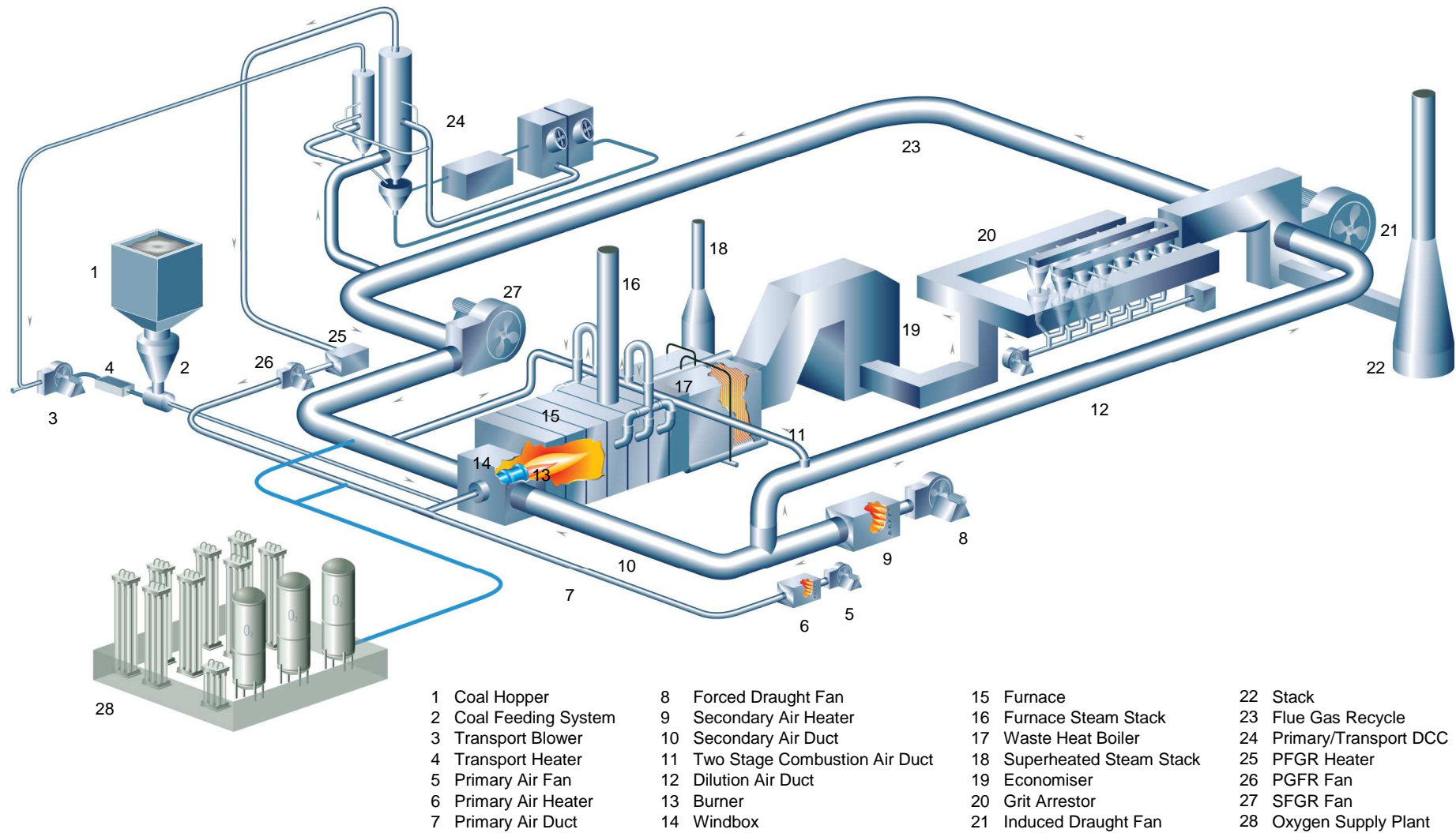

Figure 6: Layout of the Clean Combustion Test Facility (CCTF) after upgrade for oxyfuel combustion (cf. Figure 2).



Figure 7: View of the burner gallery after upgrade for oxyfuel combustion (cf. Figure 3).

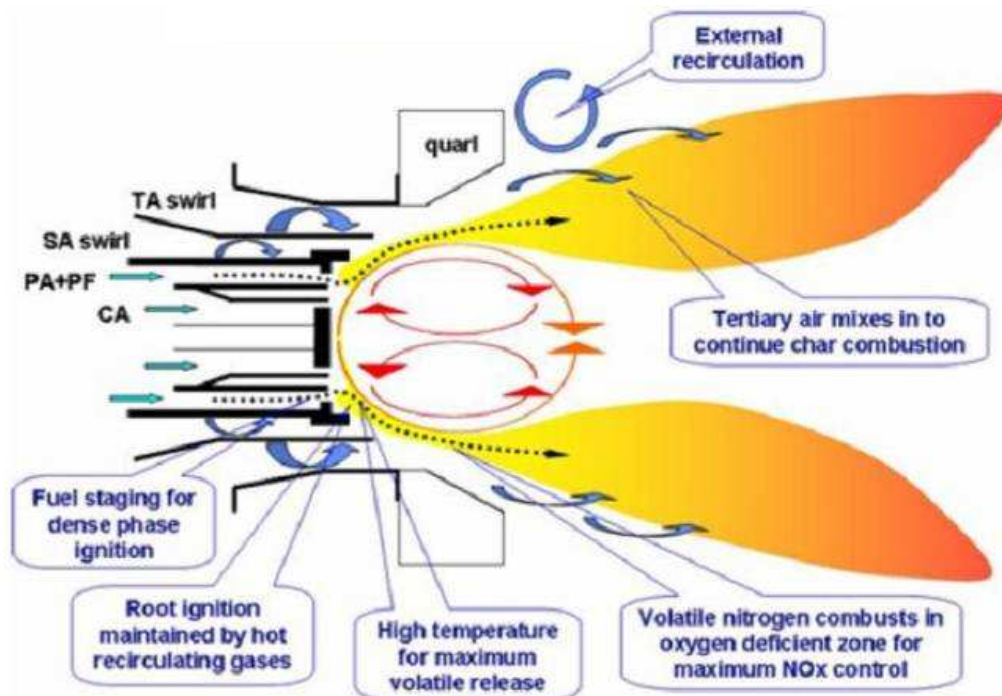

Figure 8: Schematic diagram of the OxyCoal™ burner.

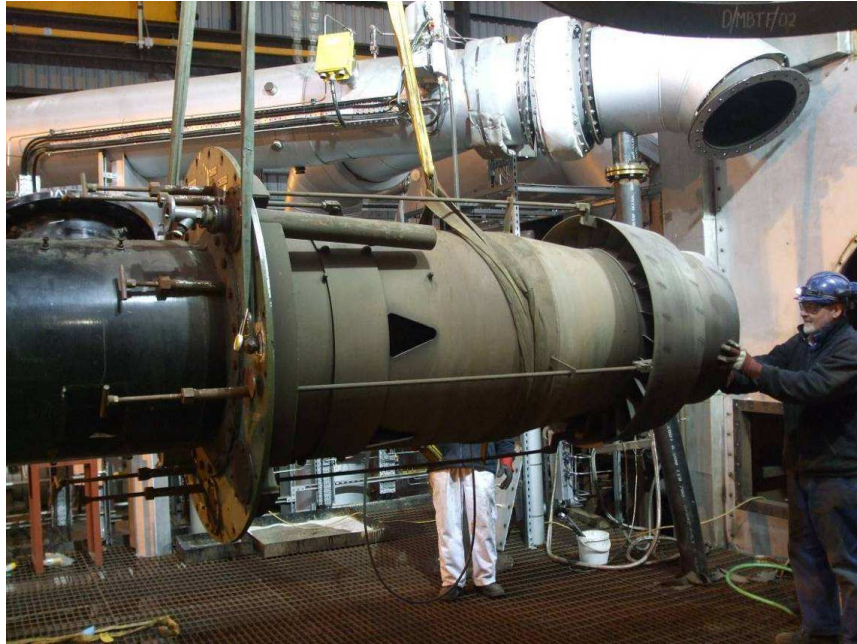

Figure 9: The OxyCoal™ burner during installation at the CCTF.

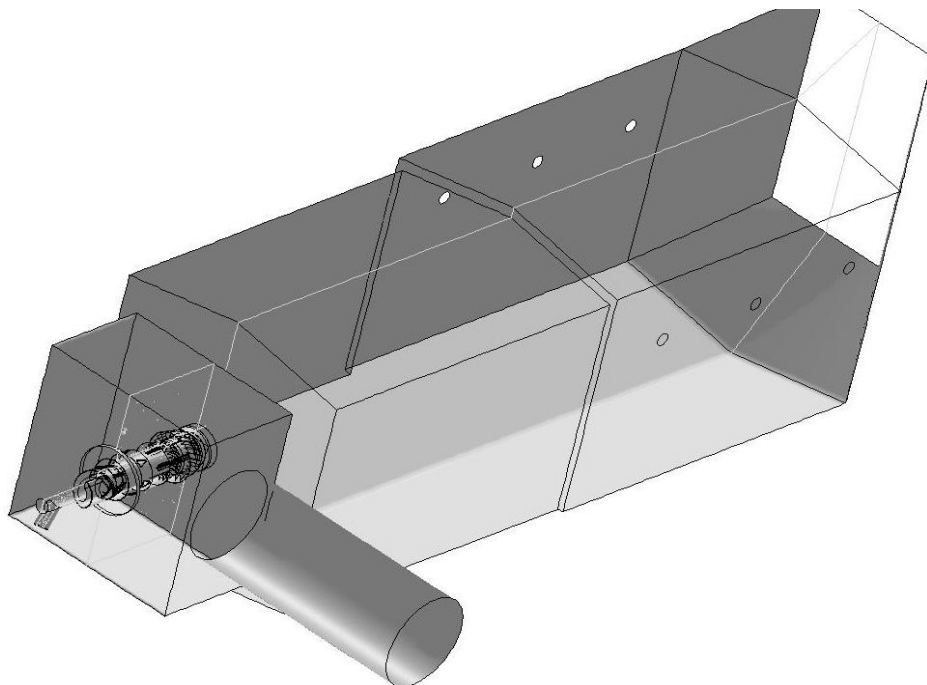

Figure 10: Modelled geometry of the 40MW_t OxyCoal™ burner installed at the CCTF.

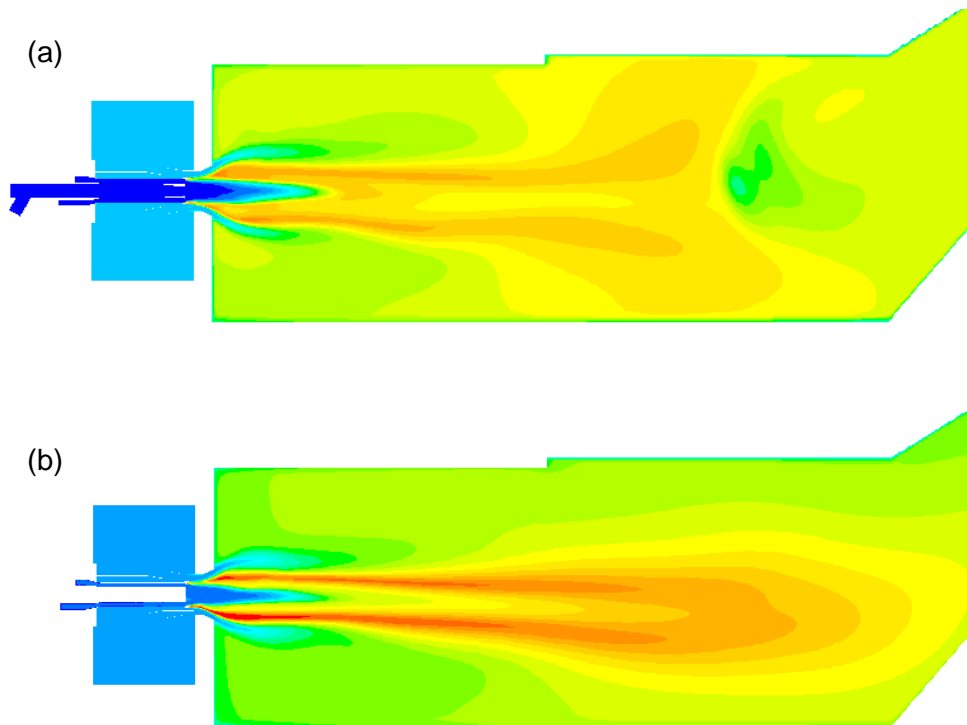

Figure 11: Predicted gas temperatures: (a) air-firing, (b) oxyfuel-firing.

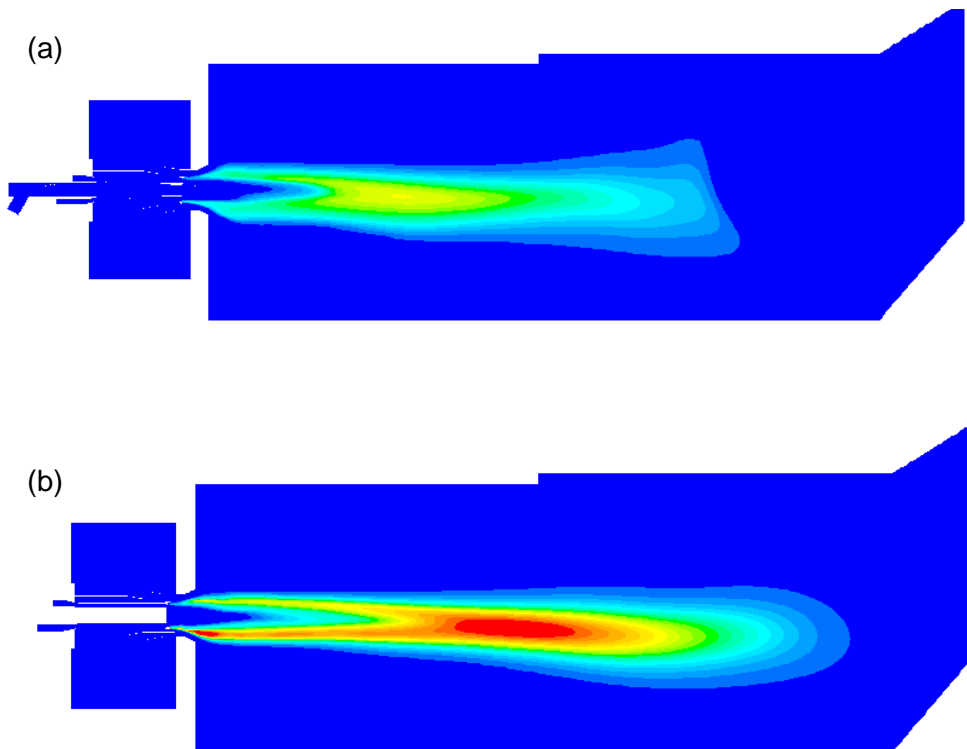

Figure 12: Predicted CO concentration: (a) air-firing, (b) oxyfuel-firing.

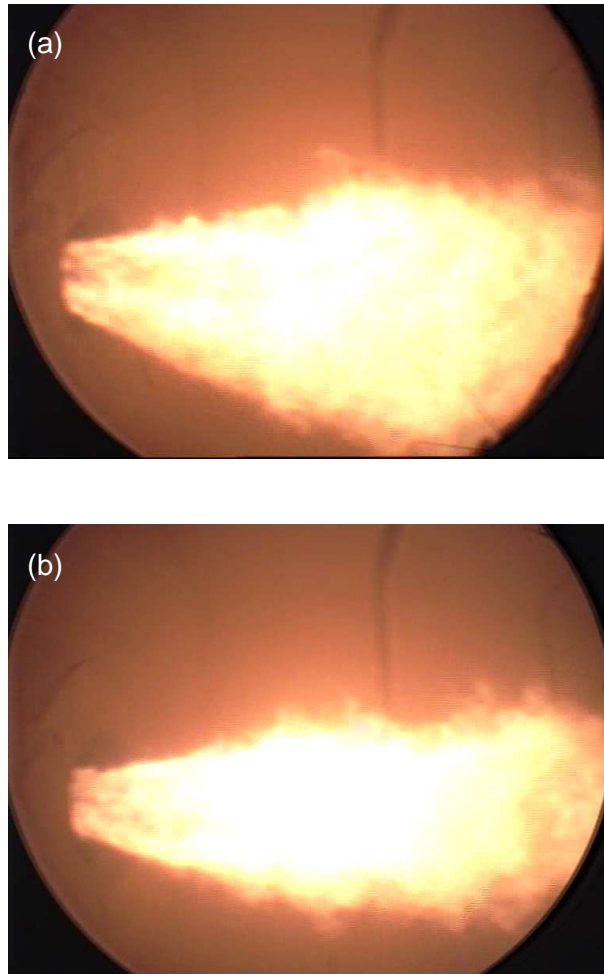

Figure 13: Flame images: (a) air-firing, (b) oxyfuel-firing.

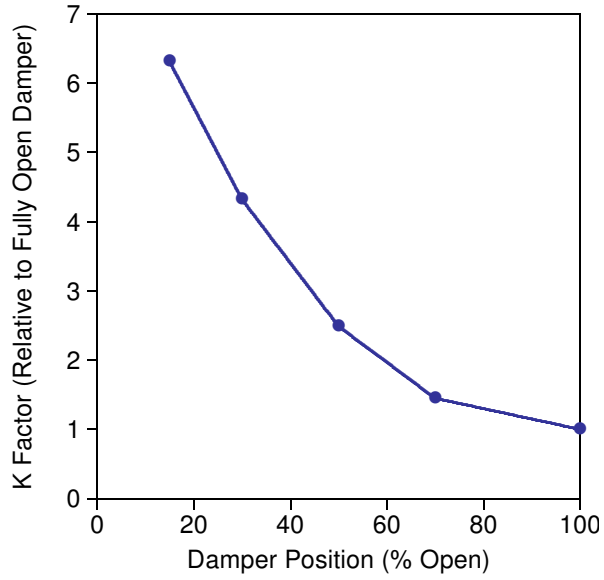

Figure 14: K-factor profile for secondary air damper.

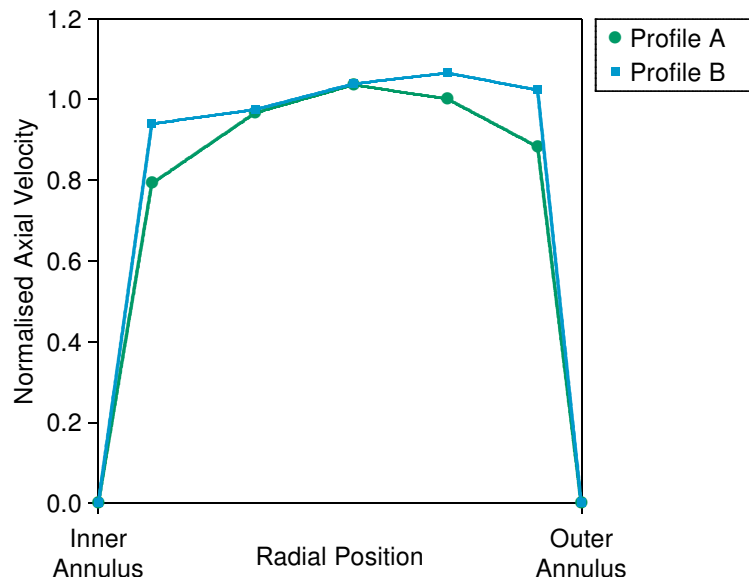

Figure 15: Velocity profiles across tertiary air annulus.

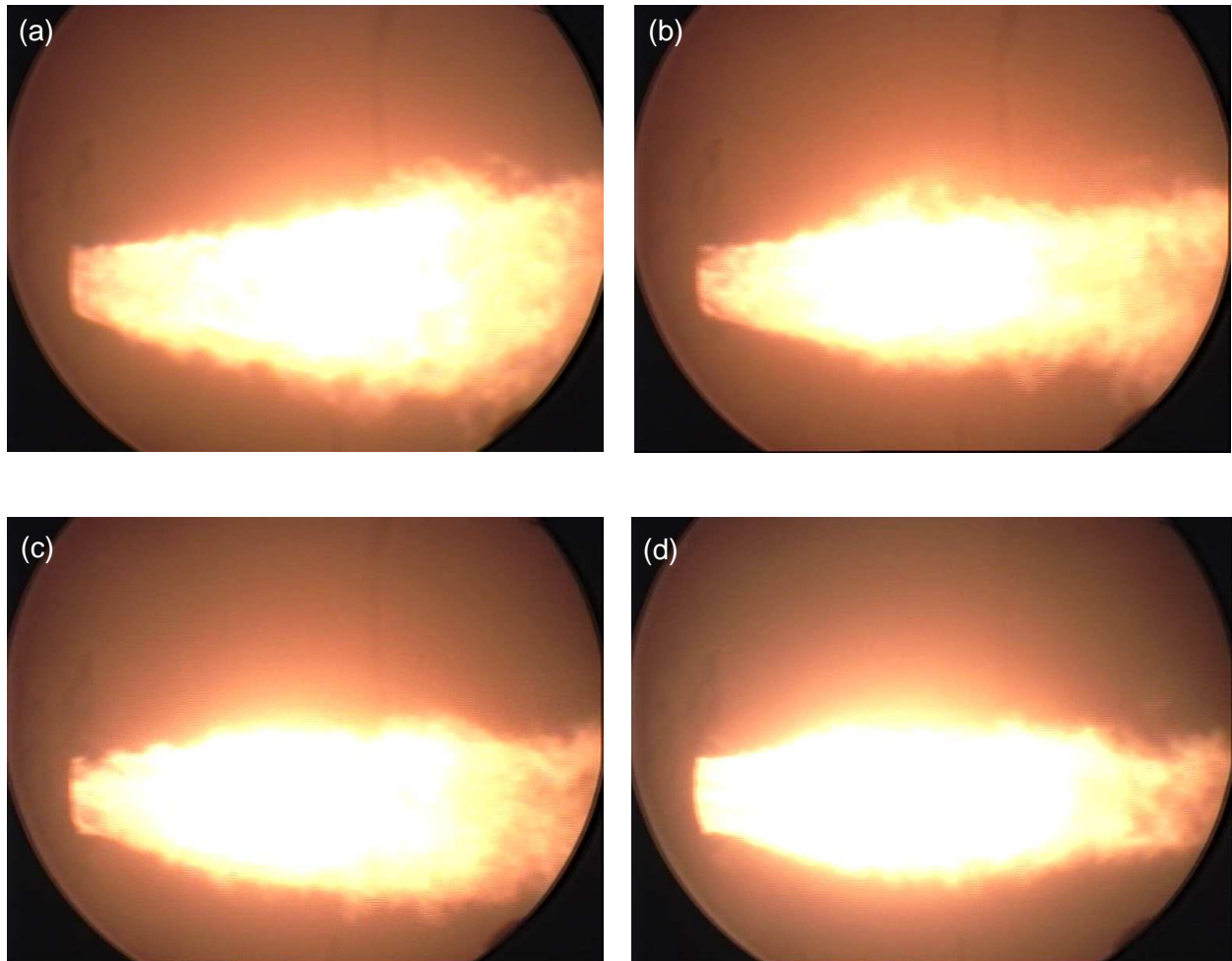

Figure 16: Flame images during turndown: (a) 32 MW_t, 80% MCR; (b) 24 MW_t, 60% MCR; (c) 20MW_t, 50% MCR; (d) 15 MW_t, 38% MCR.

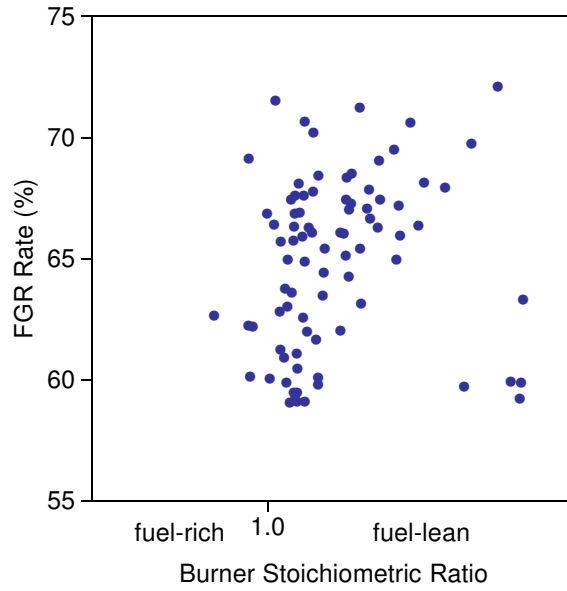

Figure 17: Summary of testing envelope.

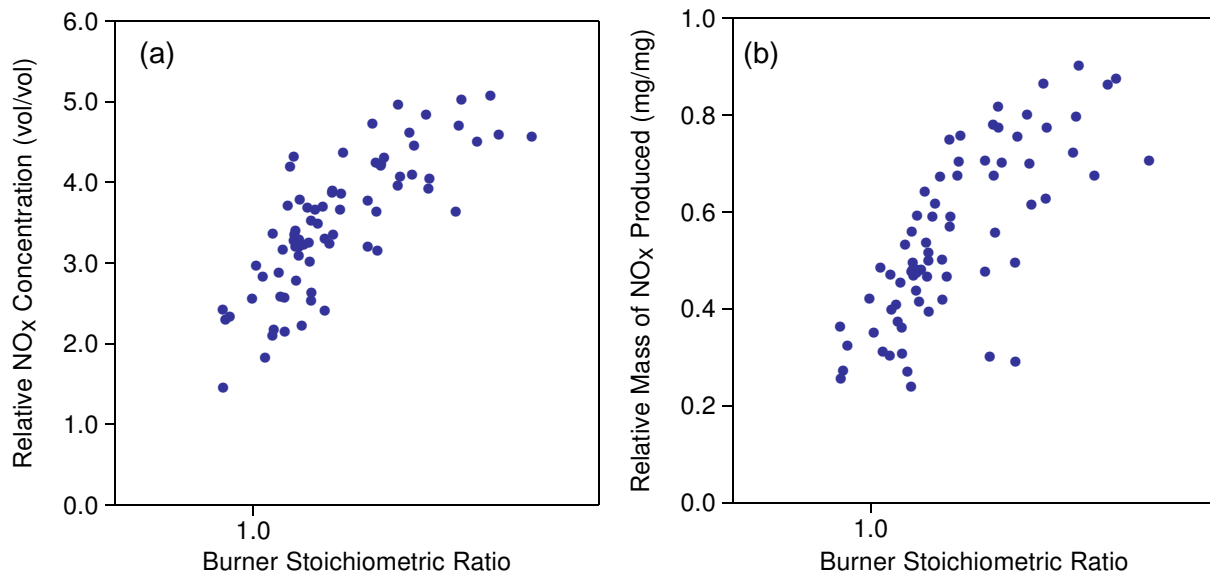

Figure 18: NO_x production under oxyfuel-firing, relative to the mean air-firing value: (a) concentration, (b) mass.

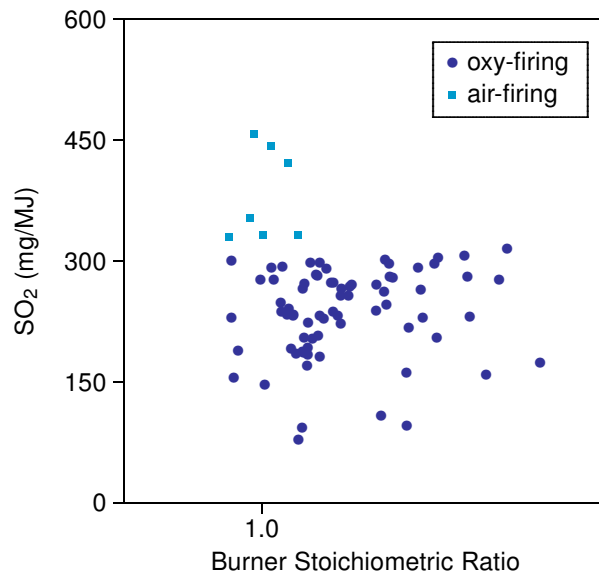

Figure 19: Production rate of SO₂ for air-firing and oxyfuel-firing.

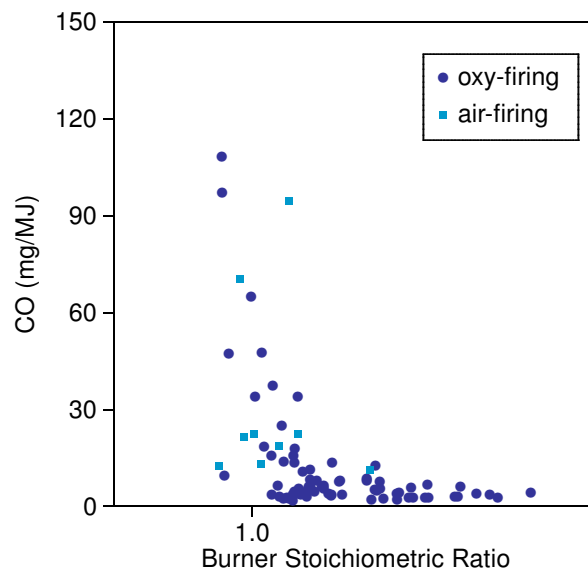

Figure 20: Production rate of CO for air-firing and oxyfuel-firing.

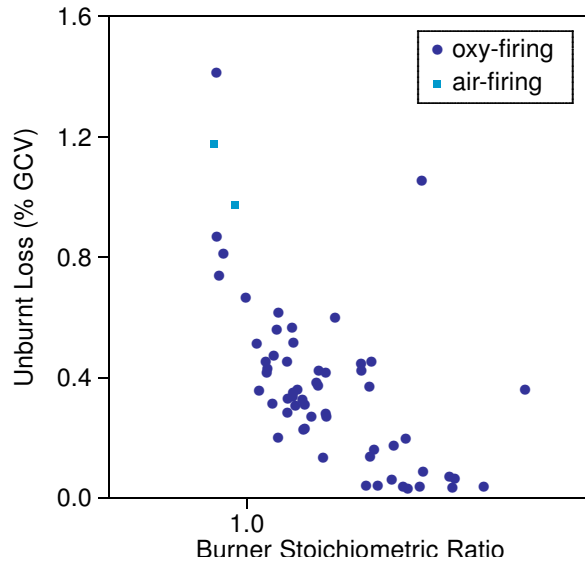

Figure 21: Unburnt loss for air-firing and oxyfuel-firing.

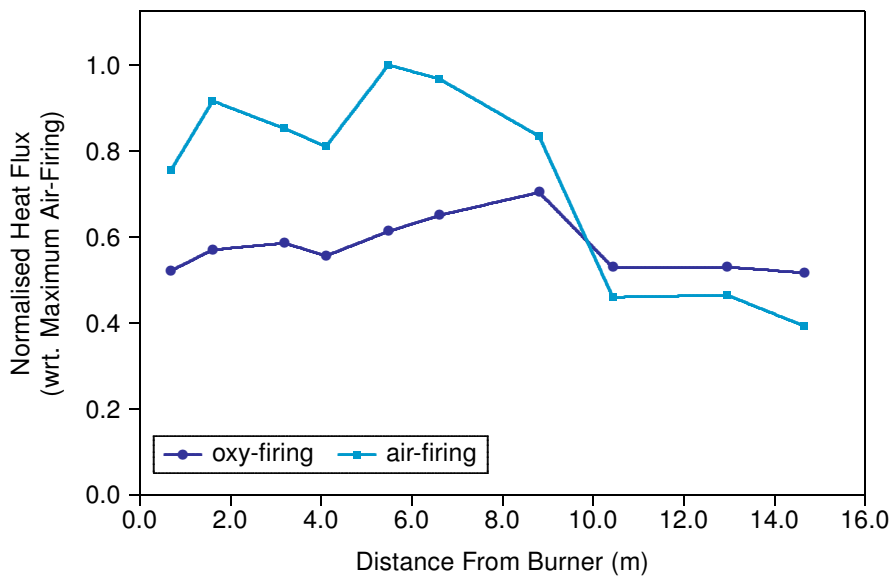

Figure 22: Heat flux profiles along the side wall of the furnace.