

FINAL TECHNICAL REPORT

Drought resistance in upland rice:
genetic analysis and varietal improvement

Plant Science Research Programme
Project R6673

June 1996-September 1999

Centre for Arid Zone Studies

Contents

PROJECT DETAILS	3
ACKNOWLEDGEMENTS	3
EXECUTIVE SUMMARY	4
BACKGROUND	5
PROJECT PURPOSE	6
RESEARCH ACTIVITIES	7
OUTPUTS	9
CONTRIBUTION OF OUTPUTS	15
REFERENCES	17
GLOSSARY	18

PROJECT DETAILS

Date of Final Technical Report: November 1999

Authors: Dr Katherine Steele & Dr Adam Price

Title: Drought resistance in upland rice: genetic analysis and varietal improvement

R number: R6673

RNRRS Programme: Plant Science Research Programme

Programme manager (institution): Centre for Arid Zone Studies

	<u>Planned</u>	<u>Actual</u>
Start date:	1 st June 1996	1 st June 1996
Finish date:	30 th June 1999	30 th September 1999 (addenda to 30 th Sept 1999.)
Total cost:	£279 762	£290 856 (addenda to £290 856)

ACKNOWLEDGEMENTS

The authors of this report are grateful to all those who have contributed to this project. In particular we would like to thank Dr Brigitte Courtois at IRRI, Philippines; Drs Monty Jones and Alain Audebert, at WARDA, Cote d'Ivoire; Drs John Witcombe and John Gorham at the University of Wales, Bangor, UK; Dr Steve Quarrie, at the John Innes Centre, UK; Dr John Townend at Aberdeen University, UK; Dr Didier Tharreau at CIRAD, Montpellier, France and Dr Lawrence Clark at IACR-Rothamsted, UK. Technical assistance from Ms Beverley Moore at the University of Wales Bangor is acknowledged. Particular thanks are expressed to all the people who assisted with experimental work over the years.

This document is an output from a project (R6673) funded by the UK Department for International Development (DFID) for the benefit of developing countries.

EXECUTIVE SUMMARY

The purpose was to identify genes for drought resistance and improve varieties of rice for drought-prone uplands by transfer of drought-resistance genes through marker assisted selection.

Two upland varieties of rice Azucena and Bala, which differ for root and shoot mechanisms of drought resistance, had been crossed to derive a mapping population in a prior DFID project R4631. These were advanced to produce 205 F₆ recombinant inbred lines (RILs). The population was used to make a molecular linkage map with 215 AFLP and RFLP loci. The population was screened for drought-related shoot and root traits in glasshouse and field experiments in multiple locations. Traits measured include root length, thickness and mass, leaf rolling, leaf drying, and relative water content. The RILs were screened for root penetration through wax discs in a collateral project (R6373) and a QTL map for root penetration through wax was published (Price *et al.*, 1999a). Preliminary QTL maps were made for drought response traits and root characteristics (Price *et al.*, 1999b). The population was also screened for resistance to the fungal pathogen blast. The project has identified molecular markers at loci which are theoretically influencing drought resistance in rice, and has confirmed the location of some of the more notable QTLs through comparisons with other studies. Rooting ability QTLs have been shown to influence shoot responses to drought, because some drought response QTLs map in similar regions.

Five Indian upland rice varieties were screened with RFLP markers for polymorphism. Kalinga III was selected for root-trait improvement by marker assisted selection (MAS). Kalinga III is popular in drought-prone areas of India but it has poor rooting ability. Four root growth QTLs were identified as targets for transfer to Kalinga III from Azucena on chromosomes 2,7,9 and 11. A gene for aroma in Azucena on chromosome 8 was also targeted for transfer. Backcrossing and MAS has resulted in BC3 lines which contain the target loci. Segregating lines from the BC2 generation with Azucena alleles at 1-3 root QTLs have been disseminated to breeders in India. These lines may have an increased ability to withstand drought and they are available for farmers to select in participatory plant breeding programmes in India and Nepal.

BACKGROUND

Upland and rainfed-lowland rice are not irrigated and so are prone to water deficit. Upland rice is mainly grown by subsistence farmers on marginal land, while rainfed-lowland rice production supports some of the world's poorest communities. The yield of upland rice is low, averaging 1 t ha⁻¹ compared to the world average of 3.5 t ha⁻¹, and farmers tend to grow traditional varieties. Drought has been identified as the most important constraint on rainfed-upland and -lowland rice productivity by farmers in N.E.India and West Africa (Arrandean, 1994).

Drought resistance in rice is physiologically and genetically complex, and there are a number of traits which are thought to contribute to drought resistance mechanisms. Lines which grow best during drought maintain high leaf water potential, and this tends to be associated with large root length (Fukai and Cooper, 1995). Maximum root length and adventitious root thickness of rice varieties have been shown to correlate with drought resistance (Ekanayake *et al.*, 1985) and deep root-to-shoot ratios of rice varieties are well correlated with drought resistance under field conditions (Yoshida & Hasegawa, 1982). Fukai and Cooper (1995) suggest that increased root-length density at depth would be useful for upland rice. Other mechanisms which allow the plant to maintain water status as rainfall fails, such as shoot dehydration avoidance mechanisms, might be valuable for all drought environments. The ability of roots to penetrate hard pans would benefit rainfed lowland conditions.

Drought-related traits are quantitative and are under the influence of several or many genetic loci. Molecular linkage maps allow identification of quantitative trait loci (QTLs), and corresponding molecular markers can be used for selection in breeding to improve varieties for drought resistance. Rice mapping projects in the USA and Japan have identified numerous RFLP probes which are publicly available for mapping. AFLPs are more efficient at detecting polymorphic alleles than RFLPs and can be included to saturate the linkage map. Trait data recorded from mapping populations can be mapped to quantitative trait loci (QTLs). Computer software has been developed for analysis of mapping data and QTL analysis (Lander *et al.*, 1987; Lincoln *et al.*, 1992).

Three populations have been developed to study the mechanisms contributing to drought resistance in rice. There are two populations developed by IRRI: a recombinant inbred line (RIL) population from a cross of CO39 x Moroberekan, and a double haploid population from a cross of Azucena x IR64. Another population of RILs from a cross between Bala x Azucena has been developed at Bangor in the DFID-funded project R4631. The IRRI populations have been used to map QTLs controlling root morphology and drought avoidance (Champoux *et al.*, 1995; Yadav *et al.*, 1997) and comparison of QTLs between populations indicates the most significant ones for use by breeders. QTLs for root penetration (Ray *et al.*, 1996), osmotic adjustment (Lilley *et al.*, 1996) and drought response traits such as leaf drying, leaf rolling and biomass under stress have also been mapped (Courtois *et al.*, 1996).

The Bala x Azucena population is derived from a cross between two upland varieties and it segregates for many important mechanisms of drought resistance including root morphology and leaf rolling. The F₂ has been used to identify QTLs for root characteristics (Price & Tomas, 1997) and stomatal conductance, leaf rolling and heading date (Price *et al.*, 1997).

The population has been advanced to the F₆ and in this project RILs were screened for root and drought traits in the field and in glasshouse studies.

Using comparative mapping four root growth QTLs were identified as targets for use in marker assisted selection to improve Kalinga III. Kalinga III is an upland variety which has been popularised in the drought prone areas of India through participatory varietal selection by the DFID funded bilateral project in India. Farmers selected it because of its earliness and superior grain and cooking quality, but it has poor rooting characteristics, and its roots are thinner and shorter than Azucena. Kalinga III and Azucena are polymorphic at most RFLP markers at the four target root growth QTLs (project R7080). The initiation of a marker assisted selection programme for the improvement of Kalinga III for root traits using Azucena QTLs was a major objective of this project. Azucena is aromatic and the transfer of the aroma gene (mapped to chromosome 8; Anh *et al.*, 1992) to Kalinga III could increase the market value of this variety, which should benefit the farmers. Therefore the aroma gene was included as a target for marker assisted selection.

PROJECT PURPOSE

The project purpose as prescribed by DFID, was “Physiology of drought resistance understood and plant genes for drought resistance transferred into adopted genetic backgrounds”.

Specifically, the objectives were:

1. To identify genes for drought resistance in upland rice using molecular markers and QTL analysis.
2. To improve varieties for drought prone uplands by the transfer of genes for drought resistance using marker-assisted-selection.

RESEARCH ACTIVITIES

Production of a genetic linkage map of upland rice with molecular markers

The Bala x Azucena F₆ population was screened with RFLPs at Bangor and AFLPs at JIC. RFLP probes were obtained from Cornell University, USA and MAFF, Japan. Mapmaker EXP software was used to construct a molecular linkage map with 215 marker loci.

Root screens

The Bala x Azucena F₆ RILs and parent varieties were screened for hydroponic root growth in Bangor (1996), root growth in soil boxes at Aberdeen University (1997), root growth in thin glass chambers at Bangor University (1997 and 1998), and root penetration through wax at Rothamsted (1997). The aim of these activities was to measure traits including: maximum root length, thickness, volume, root dry weight, shoot dry weight, total dry mass of the plant, water use from different depths, leaf rolling, gas exchange parameters, relative water content, osmotic potential and chlorophyll content, and number of roots penetrating a hard layer. Comparisons were made for these traits in soil and hydroponics, and under droughted and well-watered conditions in the soil experiments.

QTL mapping of root traits

The data collected above has been used or is presently being used to locate QTLs associated with root traits potentially contributing to drought resistance. Data was analysed using the computer software Mapmaker QTL and QTL cartographer. QTLs for root penetration have been identified and published (Price *et al.* 1999a) while the preliminary analysis of soil box and thin chamber experiments has also been published (Price *et al.* 1999b).

Field drought screens for QTL mapping

Two dry season field drought-screens were conducted at IRRI (1996 and 1998) and two at WARDA (1997 and 1998). These were replicated vegetative stage screens and irrigation was withheld from droughted replications. The Bala x Azucena F₆ RILs and parent varieties were screened in both droughted and irrigated plots. Leaf rolling and drying were assessed visually in all screens, and in IRRI 1998 and both WARDA screens relative water content was assessed. Preliminary QTL maps of field drought responses in IRRI and WARDA (without 1998 results) have been published (Price *et al.* 1999 b) and more thorough analysis of the complete data set is being undertaken at present.

QTL mapping blast resistance

The Bala x Azucena F₆ RILs were screened at CIRAD, Montpellier for blast resistance and a major gene mapped to chromosome 8 with a minor QTL on chromosome 12.

Identification of Indian variety to improve by marker assisted selection

Five Indian varieties which could be improved for drought resistance were tested for molecular polymorphism with Azucena. Four Indian varieties were included for root screening in thin glass chambers at Bangor University in 1998. The upland variety Kalinga III was selected for root trait improvement because it is popular with farmers in Eastern India and Nepal, and it has thinner and shorter roots than Azucena.

Marker assisted selection for root QTLs

Comparative QTL mapping using preliminary data from the Bala x Azucena F₂, the Azucena x IR64 population (B. Courtois, IRRI, personal communication) and the Co39 x Moroberekan population (Champoux *et al.* 1995) was used by A. Price and B. Courtois to identify root growth QTLs for transfer from Azucena to an Indian variety (Table 1). Marker assisted selection (MAS) for four root growth QTLs and aroma was carried out in Kalinga x Azucena material backcrossed to Kalinga III. The original and BC1 crosses were made at IRRI by B Courtois, and BC2 and BC3 crosses were made in Bangor. Lines were selected which contained Azucena RFLPs at the target loci.

Table 1. Target QTLs for Marker assisted Selection

Chromosome	QTL +ve effect	Nearest RFLP markers	Mapping populations in which QTLs identified
2	Root length Root thickness Root penetration	G39-C601	CO39 x Moroberekan Azucena x IR64 Bala x Azucena
7	Root length Root mass	RG650-C507	Azucena x IR64
9	Root length Root mass	G385-G1085	Azucena x IR64
11	Root length Root penetration	RG2-G1465	CO39 x Moroberekan Bala x Azucena
8	Aroma	G1073-R2676	Cornell maps

Travel

A. Price visited IRRI, Philippines, and WARDA, Cote d'Ivoire, in 1996, 1997 and 1998 to plan, supervise and analyse dry season field drought screens. A. Price presented a poster at the conference 'Plant and Animal Genome VI' at San Diego, CA, in January 1998. A. Price and K. Steele visited IRRI in 1998 to attend the 'Workshop on Genetic Improvement of Rice for Water Limited Environments'.

OUTPUTS

- A molecular linkage map of the Bala x Azucena F₆ population with 215 loci was produced. The map contains 17 linkage groups consisting of 101 RFLP and 34 AFLP uniquely placed. A further 5 RFLP and 75 AFLP markers are mapped to approximate positions. The map is shown in Figure 1.
- A QTL map for root penetration through wax has been accepted for publication (Figure 2).
- QTLs for blast resistance were mapped.
- Preliminary QTL maps were made for drought-response traits from field drought-screens at IRRI (1996 and 1998) and WARDA (1997 and 1998) (Figure 3 and Table 1). This preliminary analysis was presented at the 'Workshop on Genetic Improvement of Rice for Water limited environments', IRRI, 1-3rd December 1998, and is accepted for publication (Price *et al.*, 1999b). The data still requires further analysis and this will be done in the follow-up project (R7435).
- Preliminary QTL maps and for root morphology traits from data collected in glasshouse soil experiments were made (Figure 4 and Table 2). This was also presented in the above workshop and publication. Further analysis on the complete data-set is underway.
- Kalinga III was modified using marker assisted selection for four target root growth QTL and aroma. 31 BC3 lines have been derived which are heterozygous for at least one of the target loci, and approximately 100 segregating seed are available from each line. Two lines contain at least 3 loci and their progeny are being screened to make pyramid crosses combining all QTLs in one line. [BC3 line 21-01-03 has the target markers on chromosomes 2, 8 and 11; and BC3 line 42-01-05 has them on chromosomes 7, 8 and 9].
- Segregating lines (Kalinga III x Azucena BC2F₂) were produced and disseminated to plant breeders in India for seed multiplication. Approximately 100 seed from 59 lines have been given to breeders in India and Nepal. The lines will be grown by farmers in Eastern India and Nepal for participatory plant breeding (PPB).
- A. Price was invited to speak at the New Phytologist Conference 'Putting Plant Physiology on the Map' at Bangor University in April 1997 and presented a paper entitled 'Locating genes for drought resistance in upland rice'. A. Price presented a poster entitled 'Mapping QTLs associated with drought resistance in populations of upland rice derived from a cross between varieties Bala and Azucena' at the conference Plant and Animal Genome VI' at San Diego, CA, in January 1998. A. Price was invited to present a paper entitled 'Mapping root and shoot traits in rice: experience in UK, IRRI and WARDA' at the 'Workshop on Genetic Improvement of Rice for Water limited environments', IRRI, 1-3rd December 1998.

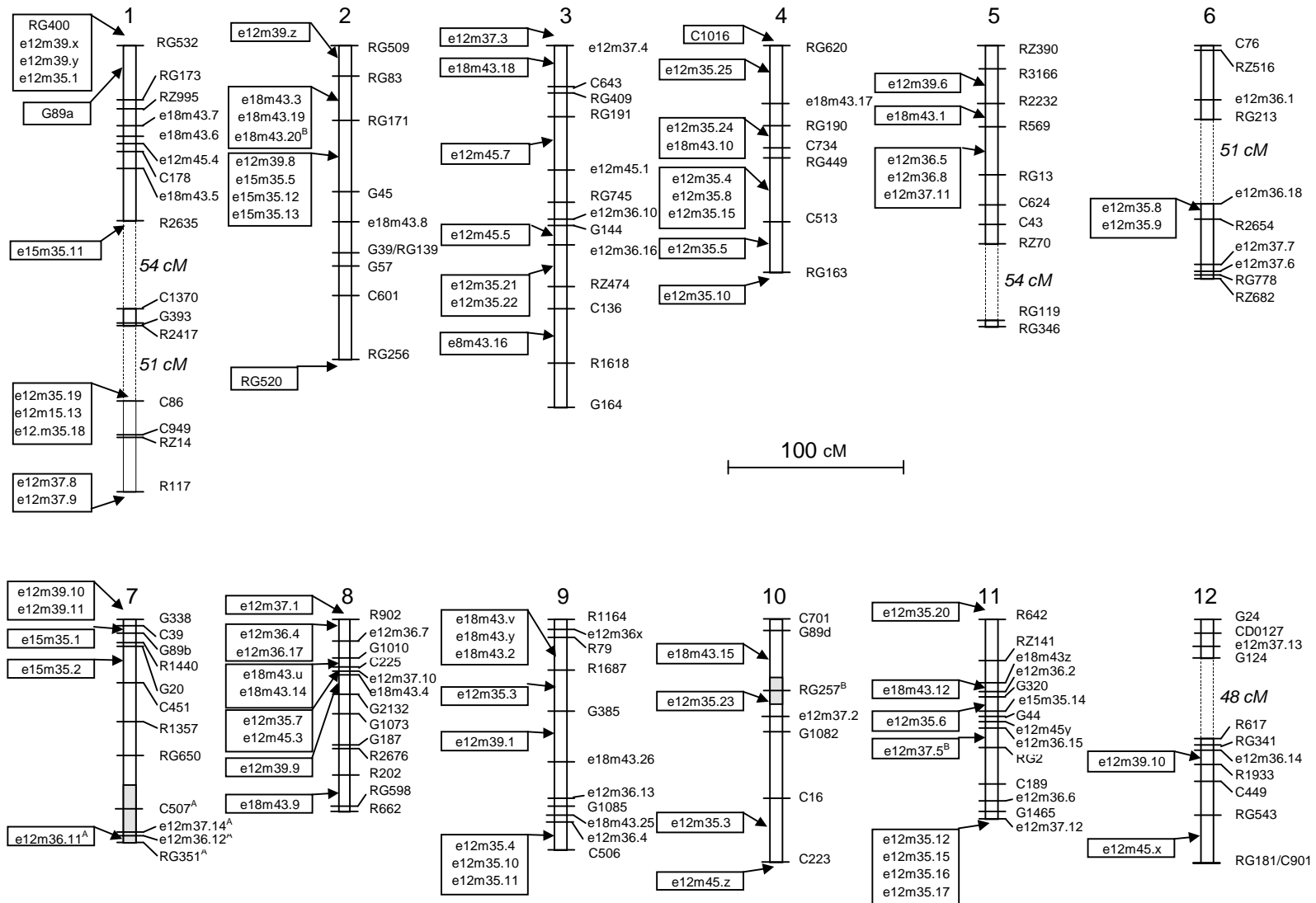

Figure 1 Combined RFLP and AFLP linkage map of rice obtained from an F_6 population derived from a cross between Bala and Azucena. Boxes on the left of the chromosome represent the most likely location of markers excluded from the map because MapMaker could not place them uniquely, because they increased map size or because they contained insufficient data. Markers with a suffix A or B were significantly skewed towards the Azucena or Bala parent respectively.

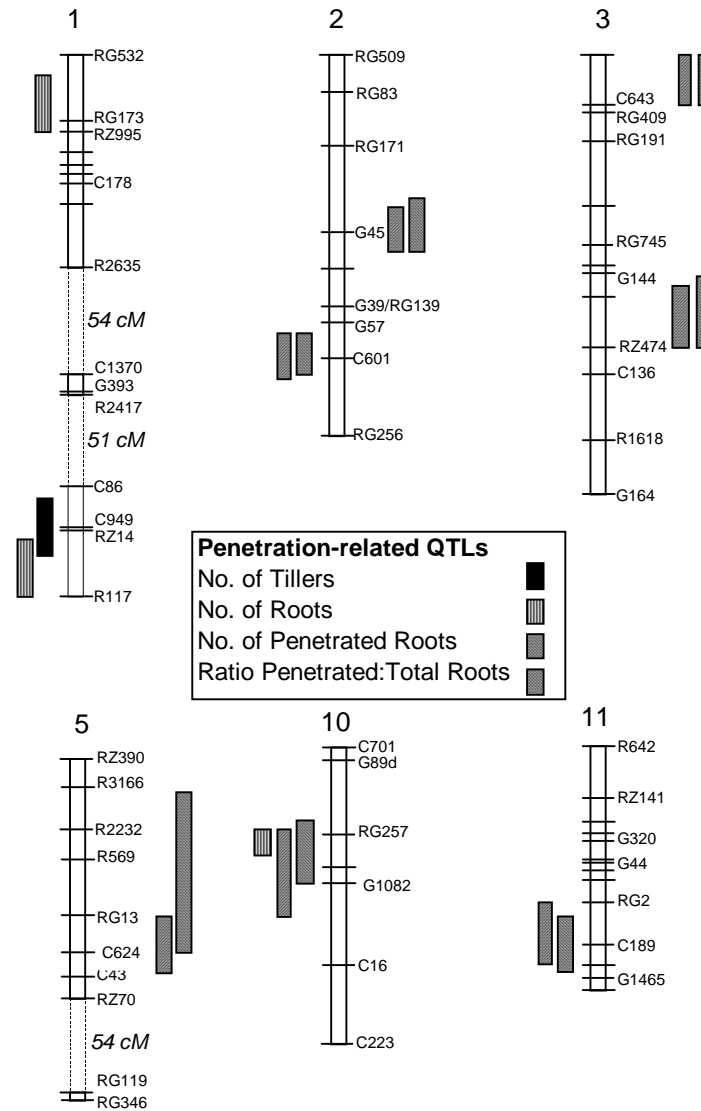

Figure 2 Quantitative trait loci (QTLs) for characters related to root penetration. QTLs were declared present by single marker regression ($P < 0.01$). The location of the QTLs was determined by composite interval mapping. Boxes represent the one LOD confidence interval. Boxes to the left of each chromosome identify QTLs where Azucena alleles have a positive effect whereas boxes to the right identify QTLs where Bala alleles have the positive effect.

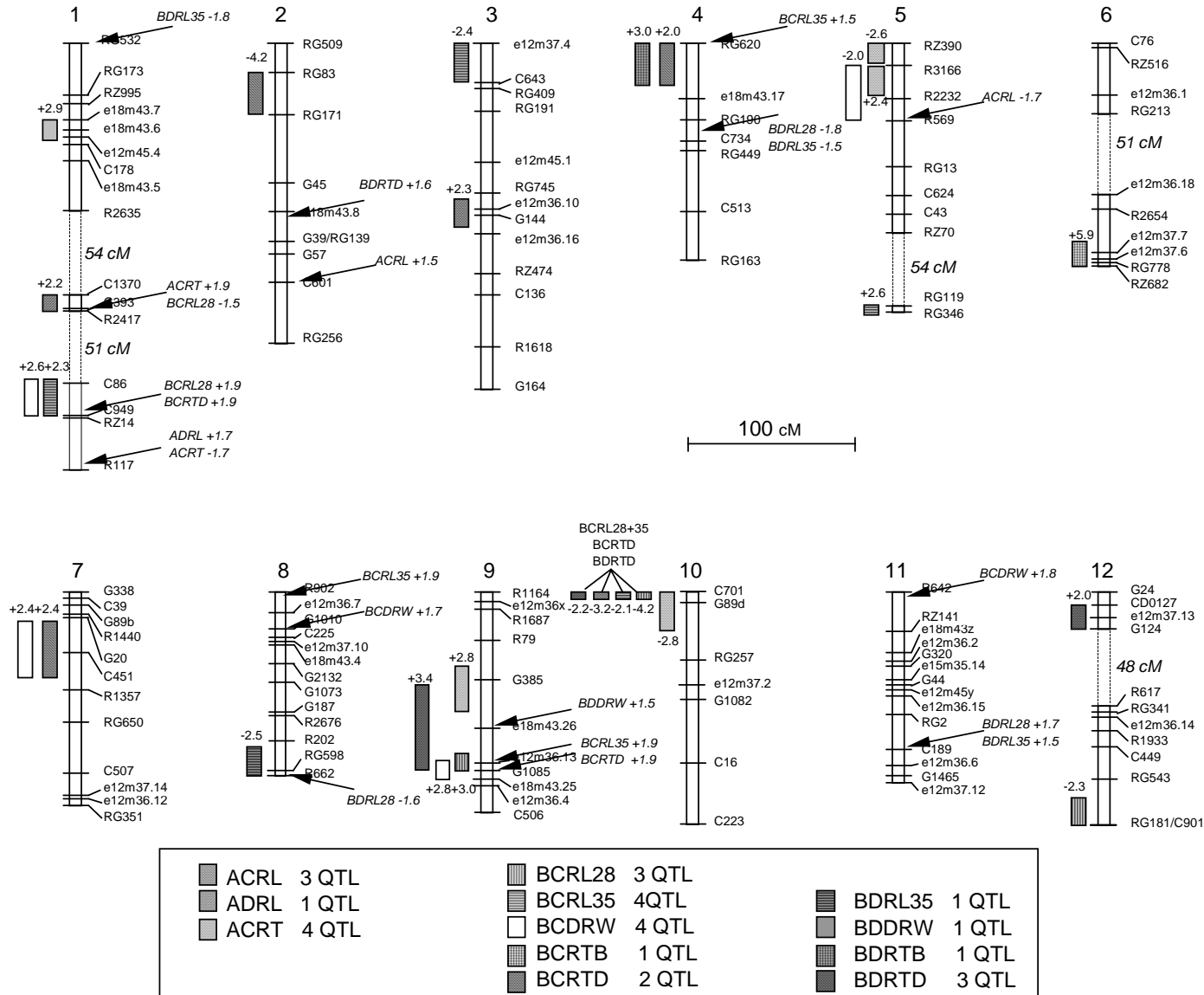

Figure 4. QTL map for root morphological traits in two screens detected by composite interval mapping. Bars represent the 1 LOD confidence interval. Numbers above or below bars indicate the LOD score supporting the QTL and the sign indicates the direction of the affect of Azucena alleles on the trait. Also presented as arrows are the positions of high LOD scores below the threshold (LOD = 1.5-1.9).

Table 2. Abbreviations for traits presented in figures 3 and 4

Abbreviation	Description
Drought reaction traits	
I96LRA	IRRI 1996 season, leaf rolling average
I96LDA	IRRI 1996 season, leaf drying average
I98LRA	IRRI 1998 season, leaf rolling average
I98LDA	IRRI 1998 season, leaf drying average
I98RWCA	IRRI 1998 season, relative water content average
WLDA	WARDA, leaf drying average
WLR16	WARDA, leaf rolling after 16 days drought
Root morphology traits	
ACRL	Aberdeen control, maximum root length
ACRT	Aberdeen control, adventitious root thickness
ADRL	Aberdeen drought, maximum root length
ADRT	Aberdeen drought, adventitious root thickness
BCRL28	Bangor control, maximum root length after 28 days
BCRL35	Bangor control, maximum root length after 35 days
BCDRW	Bangor control, deep root dry weight
BCRTB	Bangor control, root thickness at base
BDRTD	Bangor control, root thickness deep (at 75 cm depth)
BDRL28	Bangor drought, maximum root length after 28 days
BDRL35	Bangor drought, maximum root length after 35 days
BDDRW	Bangor drought, deep root dry weight
BDRTB	Bangor drought, root thickness at base
BDRTD	Bangor drought, root thickness deep (at 75 cm depth)

CONTRIBUTION OF OUTPUTS

The Project Memorandum identified the following outputs:

1. Molecular map of Bala x Azucena F₆ population with approx 200 loci produced
2. QTL maps of drought resistance-related traits produced and molecular markers identified.
3. QTL maps of field drought resistance at multiple locations and growth stages produced and molecular markers identified.
4. Indian upland varieties available with improved drought resistance for breeding programmes.

The outputs of this project have been achieved.

The Bala x Azucena F₆ population segregates for root and shoot traits and allows the genetics of several different drought related mechanisms to be investigated. QTL maps indicate that there are many genomic regions in upland rice which are involved in the drought response. Preliminary QTL maps of root growth traits suggest that some regions influencing field reaction to drought are related to root thickness, depth or penetration ability. For example on chromosome 2 there is a QTL associated with the marker C601 for increased leaf rolling and reduced leaf drying in Azucena, and this region appears also to promote deeper and more penetrating roots in Azucena. A similar effect was detected for decreased leaf drying in Azucena on chromosome 9 where a cluster of QTLs for root morphology were identified. The QTL map of root penetration-related QTLs supports previous data that QTLs exist on chromosomes 2 and 11 for enhanced root growth. Such results support the choice of the targets chosen for marker assisted selection.

Further analysis of the now complete data-set is being conducted for publication in order to disseminate the results more fully. The mapping population continues to be used for genetic research on drought resistance by scientists at IRRI (Rene Lafitte) and Hazaribagh University, India (Professor Prasad) and for the isolation of blast resistance genes at CIRAD, Montpellier (Didier Tharreau). Adam Price has obtained funding from the BBSRC to produce near isogenic lines from some of the population for research aimed at identifying the physiological and genetic basis of a few of the QTLs.

Four root growth QTLs were identified as targets for marker assisted selection because they have a positive effect on root growth under experimental conditions in the Bala x Azucena and/or other mapping populations. Molecular markers at these target loci have enabled transfer of these chromosomal regions from Azucena into the elite variety Kalinga III. The gene for aroma has also been transferred into Kalinga III, which could potentially increase its market value. Lines containing the target QTLs in a Kalinga III genetic background are now available to upland rice breeders and will be screened using participatory breeding approaches in the PSP-funded project R7434. As a result of this work farmers will be exposed to lines which may have a greater ability to withstand drought. Further crosses are being carried out to pyramid the QTLs and the derived lines will be advanced in project R7434, and root screens on selected lines will be done to confirm the specific effects of the introduced QTLs. Participatory plant breeding will determine the suitability of the improved material for use by farmers. This will identify their preferences for the improved material, and if popular the seed will be disseminated by the farmers themselves.

The project has generated much data, some of which has yet to be analysed fully. It is clear from the results that there is a considerable environmental effect on the identified QTLs. Drought resistance is complex and it still remains to test how the gene loci identified here interact with each other and with the environment. These issues are being explored in project R7435 and the data generated in this project will be further assessed.

The knowledge generated about the genetic control of drought resistance will benefit rice researchers and breeders throughout the world. The results from this project will be submitted to RiceGenes, the database for the rice genome. The information will be valuable to for the rice genome sequencing project, and by comparison of QTL maps with sequences it will be possible in the future to identify the individual genes which are contributing to drought resistance. However in the short term the use of MAS for QTLs is being used for the improvement of varieties for these traits without knowledge of specific gene products.

Publications

Price A.H., Steele K.A., Moore B.J., Barraclough P.B. and Clarke L.J. (1999a). A combined RFLP and AFLP linkage map of upland rice (*Oryza sativa* L.) used to identify QTLs for root penetration ability. *Theoretical and Applied Genetics* (in press).

Price A., Steele K., Townend J., Gorham J., Audebert A., Jones M. and Courtois B. (1999b). Mapping root and shoot traits in rice: experience in UK, IRRI and WARDA. *Proceedings of the Workshop on Genetic Improvement of Rice for Water Limited Environments, 1-3 December, 1998*. IRRI Publications, Los Baños, Philippines (in press).

Price A.H. and Courtois B. (1999). Mapping QTLs associated with drought resistance in rice: Problems, progress and prospects. *Plant Growth Regulation* **29**, 123-133.

Price AH and Tomos AD (1997). Genetic dissection of root growth in rice (*Oryza sativa* L.) II: Mapping quantitative trait loci using molecular markers. *Theoretical and Applied Genetics* **95**, 143-152

Price AH, Virk DS and Tomos AD (1997). Genetic dissection of root growth in rice (*Oryza sativa* L.) I: A hydroponic screen. *Theoretical and Applied Genetics* **95**, 132-142

Price AH, Young EM and Tomos AD (1997). Quantitative trait loci associated with stomatal conductance, leaf rolling and heading date mapped in upland rice (*Oryza sativa*). *New Phytologist* **137**, 83-91

REFERENCES

- Ahn SN, Bollich CN and Tanksley SD (1992) RFLP tagging of a gene for aroma in rice. *Theor Appl Genet* 84: 825-828
- Arraudeau M and Harahap Z (1986) Relevant upland breeding objectives. In: *Progress in upland rice research*, pp189-197. Manila: IRRI
- Causse M, Fulton TM, Cho YG, Ahn SN, Chunwongse J, Wu K, Xiao J, Yu Z, Ronald PC, Harrington SB, Second GA, McCouch SR and Tanksley SD (1995) Saturated molecular map of the rice genome based on an inter specific backcross population. *Genetics* 138: 1251-1274
- Champoux MC, Wang G, Sarkarung S, Mackill DJ, O'Toole JC, Huang N and McCouch, SR (1995) Locating genes associated with root morphology and drought avoidance in rice via linkage to molecular markers. *Theor Appl Genet* 90: 969-981
- Courtous B, Chaitep W, Moolsri S, Sinha PK., Trebuil G, and Yadav R (1996) Drought resistance and germplasm improvement: On-going research in the Upland Rice Consortium. Paper presented at the Upland Rice Consortium Meeting, Indonesia, January 9-12, 1996.
- Ekanayake IJ, O'Toole JC, Garrity DP and Masajo TM (1985) Inheritance of root characters and their relations to drought resistance in rice. *Crop Sci* 25: 927-933
- Fukai S and Cooper M (1995) Development of drought-resistant cultivars using physiological traits in rice. *Field Crops Res* 40: 67-86
- Joshi A and Witcombe JR (1996) Farmer participatory crop improvement II. Participatory varietal selection: a case study in India. *Experimental Agriculture* 32: 461-477
- Kurata N, Nagamura Y, Yamamoto K, Harushima Y, Sue N, Wu J, Antonio BA, Shoura A, Shimizu T, Lin S-Y, Inoue T, Fukuda A, Shimano T, Kuboki Y, Toyama T, Miyamoto Y, Kirihara T, Hayasaka K, Miyao A, Monna L, Zhong HS, Tamura Y, Wang ZX, Momma T, Umehara Y, Yano M, Sasaki T and Minobe Y (1994) A 300 kilobase interval genetic map of rice including 883 expressed sequences. *Nature Genet* 8: 365-372
- Lander ES, Green P, Abrahamson J, Barlow A, Daly MJ Lincoln SE and Newburg L (1987) Mapmaker: an interactive computer package for constructing primary genetic linkage maps of experimental and natural populations. *Genomics* 1: 174-181
- Lilley JM, Ludlow MM, McCouch SR and O'Toole JC (1996) Locating QTL for osmotic adjustment and dehydration tolerance in rice. *J Ex Bot* 47: 1427-1436
- Lincoln S, Daly M and Lander E (1992) Mapping genes controlling quantitative traits with MAPMAKER/QTL 1.1. Whitehead Institute Technical Report 2nd edn.

- Price AH and Tomos AD (1997) Genetic dissection of root growth in rice (*Oryza sativa* L.) II: Mapping quantitative trait loci using molecular markers. *Theor Appl Genet* 95: 143-152
- Price AH, Virk DS and Tomos AD (1997) Genetic dissection of root growth in rice (*Oryza sativa* L.) I: A hydroponic screen. *Theor Appl Genet* 95: 132-142
- Price AH, Young EM and Tomos AD (1997) Quantitative trait loci associated with stomatal conductance, leaf rolling and heading date mapped in upland rice (*Oryza sativa*). *New Phytol.* 137: 83-91
- Ray JD, Yu L, McCouch SR, Champoux MC, Wang G and Nguyen H (1996) Mapping quantitative trait loci associated with root penetration ability in rice (*Oryza sativa* L.). *Theor Appl Genet* 92: 627-636
- Yadav R, Courtois B, Huang and McLaren G (1997) Mapping genes controlling root morphology and root distribution on a double-haploid population of rice. *Theor Appl Genet* 94: 619-632
- Yoshida S and Hasegawa S (1982) The rice root system; its development and function. In: *Drought resistance in crops with the emphasis on rice*, pp83-96. Manila: IRRI

GLOSSARY

AFLP	Amplified fragment length polymorphism
BC	Back cross Population
CAZS	Centre for Arid Zone Studies
DFID	Department for International Development
IRRI	International Rice Research Institute
JIC	John Innes Centre (Norwich, UK)
KIII	Kalinga III
LOD	Log likelihood (statistical probability)
MAS	Marker Assisted Selection
PCR	DNA amplification via polymerase chain reaction
PPB	Participatory Plant Breeding
QTL	Quantitative Trait Loci
RIL	Recombinant inbred line
RFLP	Restriction Fragment Length Polymorphism
WARDA	West Africa Rice Development Association