

## HAND SLUDGING

### A REPORT FROM NORTH WEST BENGAL

Peter Ball and Kerstin Danert

March 1999



an internal report of the Low Cost Drilling Project  
of Cranfield University (UK), funded by DFID,  
in partnership with Government of Uganda,  
Danida, Sida, and Unicef

---

*Project Manager:* Dr Richard C Carter  
Institute of Water and Environment, Cranfield University, Silsoe, Bedford, MK45 4DT, UK  
Tel + 44 (0)1525 863297; fax + 44 (0)1525 863344; email [r.c.carter@cranfield.ac.uk](mailto:r.c.carter@cranfield.ac.uk)

*Drilling Consultant and Rig Designer:* Mr Peter Ball  
Eureka UK Ltd, 11 The Quadrant, Hassocks, West Sussex, BN6 8BP, UK  
Tel + 44 (0)1273 844333; fax + 44 (0)1273 844332; email [peterball@eurekawater.com](mailto:peterball@eurekawater.com)

*Uganda Project Team:* Eng Kerstin Danert (Team Leader); Mr Ezron Rwamwanja (Community Water Supply Specialist); Mr Jamil Ssebalu (Small Business Specialist)  
Tel + 256 (0)41 257424; email [lcdrilling@yahoo.com](mailto:lcdrilling@yahoo.com)

Website: <http://www.silsoe.cranfield.ac.uk/lcdrilling/>

Reference as: Ball, P and Danert, K (1999) Hand Sludging: a Report from North West Bengal. Report of DFID KAR Project R7126 "Private Sector Participation in Low Cost Water Well Drilling", Cranfield University. ISBN 1861940 548

---

## CONTENTS

	Page
Abstract	3
Acknowledgments	3
Background and Introduction	4
The Sludging Method	4
Equipment	5
Ergonomics	7
Cleaning	7
Drilling	8
Well Completion	9
Cost	14
Equipment Capabilities	14
Conclusions and Implications for the Low Cost Drilling Project	14

## FIGURES

Figure 1	Mistries Operating Sludging Equipment	4
Figure 2	Sludge Ejecting from the Pipe	5
Figure 3	Sludging Equipment	6
Figure 4	Mistry Starting a Hole with 1.5m Pipe	6
Figure 5	Drill Bit	
Figure 6	Observed Structure Dimensions	8
Figure 7	Power Requirements for Lever Operator when Cleaning at 0.8 strokes/s	8
Figure 8	Power Requirements for Lever Operator when Drilling at 0.8 strokes/s	9
Figure 9	Mistry Squatting	9
Figure 10	Hole Cleaning	10
Figure 11	Cutting of Bamboo Slats	10
Figure 12	Cutting the Bamboo "Doughnuts"	11
Figure 13	Bamboo Screen Construction	11
Figure 14	Bamboo Screen Structure and Netting	11
Figure 15	Screen Formed from Galvanised Pipe with Pressed out Holes Covered in Brass Sheet	12
Figure 16	Bamboo Cleaning Tool	12
Figure 17	Cleaning the Pith out of the Bamboo	13
Figure 18	Flow from an Installed 3" Diesel Pump	13

## ABSTRACT

The Low Cost Drilling Project (Cranfield University/DFID/Government of Uganda) is developing a modification of the traditional Asian sludging technology for use in Africa. As part of the technology research a visit was made to north India to observe and measure various characteristics of this well drilling technique. The report describes these observations and draws conclusions for the Low Cost Well Drilling Project.

The method and equipment used by the Indian drillers ("mistries") are set out, followed by an outline of the ergonomics and quantification of the work rates needed for hole cleaning and drilling. Drilling penetration rates in soft alluvium were observed to range from 16.5 to 45m per hour.

Traditional and more modern designs of casing and wellscreen, and the corresponding well completion methods, are described.

The cost of a 12m water well drilled by sludging in North West Bengal is estimated at Rs200 (approximately £3-4).

Practical conclusions are drawn in relation to equipment design for Uganda or elsewhere in sub-Saharan Africa.

## ACKNOWLEDGMENTS

The Project is funded by the UK Government Department for International Development (DFID). The Project operates in partnership with the Government of Uganda Directorate of Water Development through the Water and Environmental Sanitation (WES) Programme, funded jointly by GoU, Swedish International Development Assistance (SIDA), the United Nations Children's Fund (UNICEF), and the Government and People of Uganda. All these linkages and funding sources are gratefully acknowledged.

The Project Team consists of Dr Richard Carter (Project Manager), Eng Kerstin Danert (Research Engineer), Mr Peter Ball (Drilling Consultant), Mr Ezron Rwamwanja (Community Water Supply Specialist), and Mr Jamil Ssebalu (Small Business Specialist).

## BACKGROUND AND INTRODUCTION

This report discusses the technique, equipment and cost of the traditional human powered drilling method known as sludging. The information was collected on a visit undertaken by Mr Peter Ball to Cooch Bihar in North India in December 1998.

Sludging, also known as Bangladeshi Sludging, or slugging is a traditional drilling technique which is commercially entrenched in North India and Bangladesh, and practised by 'Mistries'. The Mistries are local tradesmen who have learned the process and own their own drilling equipment. They are employed to drill holes for domestic water supplies, which will use No 6 Type cast iron hand pumps and irrigation tubewells operating with treadle footpumps to 3" diesel pumps.

### Visit Itinerary

22nd Dec 1998	Depart London for Delhi - plane diverted to Bombay due to smog in Delhi
23rd Dec	Arrive Delhi p.m. and visit IDE to discuss arrangements for trip to West Bengal
24th Dec	Travel to West Bengal - flight delayed due to fog in Delhi
25th Dec	Arrive to meet IDE local personnel and drive to Cooch Bihar - tubewell drilling district
26th Dec	Visit drilling sites near Cooch Bihar
27th Dec	Visit more drilling sites around Cooch Bihar
28th Dec	Visit hardware shops selling tubewell materials and tools and travel back to Delhi
28th Dec	Return from Delhi to London

## THE SLUDGING METHOD

Two Mistries operate the rig as shown in Figure 1. The skilled practitioner has one hand on the pipe and utilises the other as a flap valve. He also takes the samples. The junior or employed crew operates the lever.



Figure 1: Mistries Operating Sludging Equipment

The hole is kept flooded to ground level throughout the drilling operation. The cuttings are removed with the water by the flap valve action of the operator's hand on the top of the hollow pipe. When the pipe is raised, the hand covers the top of the pipe, holding the water in suction and lifting it with the pipe. As the pipe starts to descend, the hand is raised and the water containing the cuttings ejects out of the top (Figure 2), thus, the percussive action is used to both drill and clean the hole. The flooded hole ensures that the suction head on the top of the drill pipe is kept to a maximum of 1.5m.



**Figure 2: Sludge Ejecting from the Pipe**

Good general hole construction technique is practised by the Mistries observed in Cooch Bihar. A shallow pit, which was kept filled with water throughout the drilling process had been dug at all of the drilling sites visited, enabling the cuttings to settle. Losses into the formation were anticipated, and reduced by adding small quantities of cow manure into the annulus to seal off zones with lost circulation. The Mistries kept the hole under construction flooded in order to exert hydrostatic head down the borehole and prevent hole collapse. The water required was fetched by the client farmer, who accepted this as an essential job to be undertaken. Note that during the visit, there was still plenty of pooled surface water available from the previous rainy season.

The Mistry holding the drill pipe, would, on occasion twist the drill pipe approximately  $1/8$  to  $1/4$  of a turn it descended. The twisting action was undertaken for approximately 50% of the stroke, with the other strokes descending without any rotation.

Observations in India showed that the percussive action occurs at a mean rate of 1.75 strokes per second, (105 per minute) with the operators speeding up or slowing down to remain comfortable. The stroke length varied between 0.2 to 0.5m with a mean of 0.4m.

## **EQUIPMENT**

The equipment used in Cooch Bihar, as shown in Figure 3, comprises a water pipe which is raised and lowered in the hole by means of a lever. The pivot is a single bamboo rod positioned 0.5m from the borehole axis. The lever is up to 2m in overall

length. When drilling deep holes up to 30m, the fulcrum remains the same but more men operate the lever.

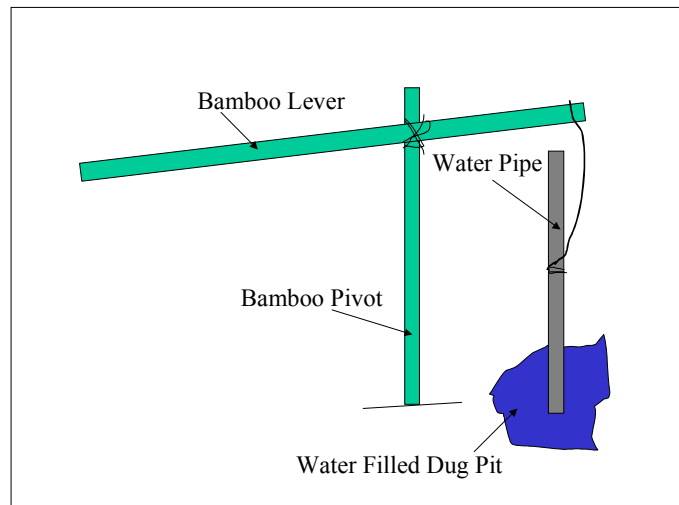

**Figure 3: Sludging Equipment**

### Drillpipe

The drillpipe is universally  $1\frac{1}{2}$ " tube, which may have originally been galvanised but has subsequently worn black.  $1\frac{1}{2}$ " couplings are used to connect the pipes. The Mistries observed in Cooch Bihar used 3.1m (10') pipe lengths. A 1.5m (5') piece was used alternately at the surface to enable the mistrie hand sludging to remain comfortably on the ground, squatting as the pipe drilled into the ground (Figures 4 and 9). This differs from the bamboo structure, which has been observed in use by other Mistries.



**Figure 4: Mistry Starting a Hole with 1.5m Pipe**



The use of 1.5m pipe at the surface avoids the need for such a structure and may maximise the efficiency of the sludging technique by ensuring that the maximum suction lift is limited to 1.5m. The pipe measured 48.5mm OD x 40.4mm bore having a weight of 12 kg for a 3.1m length.

### **Drill Bit and Drive Shoe**

The 'drill bit' (Figure 5) is a standard 1½"x 2", 3" or 4" reducing coupling. On larger sizes, the lip is internally bevelled to making a cutting edge. Generally holes only just bigger than the screen OD are cut.

The drill bit also acts as a drive which may be crucial to obtain the flow of slurry up the drill pipe. The drive shoe has a tight fit in the hole and probably forces the water into the drill pipe as the pipe descends.



**Figure 5: Drill Bit**

### **ERGONOMICS**

The lever operator raised and lowered the lever with his hands. When drilling, the operator regularly changed the position of his hands and height of his arms in order to remain comfortable. The valve operator starts off standing at the drill pipe and bends over as the pipe penetrates the ground until he ultimately ends up squatting.

### **CLEANING**

The lever mechanical advantage when cleaning is approximately 3:1. Thus the lever operator must exert a force of 108N to lift 10m water filled pipe length. During the cleaning process, the mean stroke rate was 0.8 strokes/second, with a stroke length of 1m. Thus the operator is working at a rate of approximately 86 watts. This is just above 70W, which is considered to be a comfortable rate for an adult to work at continuously. Figure 7 indicates the power requirements of the lever operator(s) for different pipe and stroke lengths.

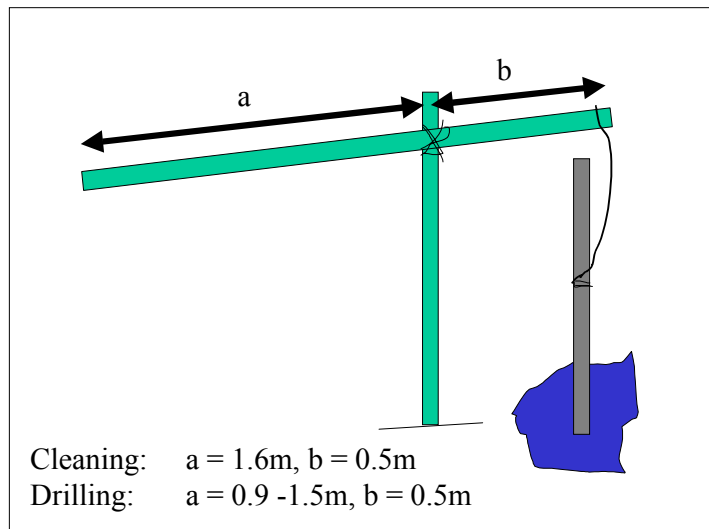

**Figure 6: Observed Structure Dimensions**

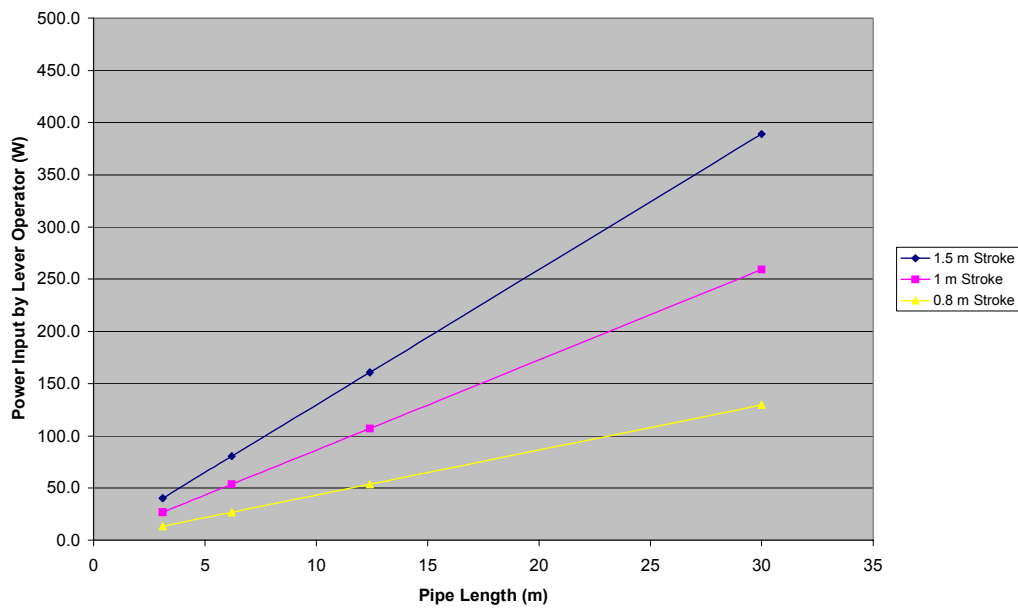
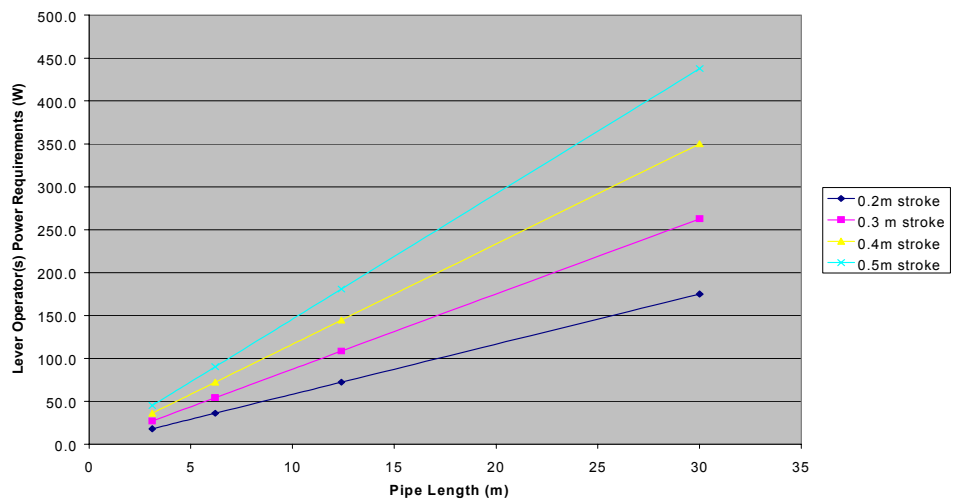

**Figure 7: Power Requirements for Lever Operator when Cleaning at 0.8 strokes/s**

### DRILLING

The lever mechanical advantage varies from approximately 2:1 to 3:1. Taking a ratio of 2:1, the lever operator must exert a force of 160N to lift 10m water filled pipe length. The stroke length varied from 20 to 50cm with a mean stroke rate of 1.8 strokes/second. Assuming a stroke length of 0.4m, and mechanical advantage of 2:1, the lever operator must work at a rate of approximately 120W for a 10m-pipe length. Figure 8 indicates the required power input by the lever operators and illustrates why it is necessary to have more than one operator, as the wells become deeper.





**Figure 8: Power Requirements for Lever Operator when Drilling at 0.8 strokes/s**



**Figure 9: Mistry Squatting**

### Penetration Rates

The mean penetration rate for the well drilling observed was 21m/hr, with rates varying from 16.5 to 45m/hr, depending on the drilling conditions.

### WELL COMPLETION

#### Cleaning

On completion of the drilling, the Mistry logs the hole depth and commences the cleaning process. The hole is washed by pouring clean water through the drillpipe into the hole and displacing the mucky drilling water. With clean water in the hole, the drillpipe is removed and the screen and casing are inserted.

Subsequently, more clean water is poured down into the casing and screen (Figure 10) and flows up the annulus, further washing fines and dirty water away from the screen. A head pan of sand removed from the hole during the drilling and washed clear of fines is used as a gravel pack and washed down the hole annulus.



**Figure 10: Hole Cleaning**

### **Casing and Screen**

All casing and screens observed are low cost solutions. The cheapest version is a fabric covered bamboo based screen. The structure is constructed from between 7 and 9 split bamboo slats 10 to 20mm wide and 5mm thick (Figure 11). They are formed on to 20mm long “doughnuts” (Figures 12 and 13) of cut bamboo. The open latticed structure is tied with string or wire. A cloth covering of either white mosquito netting (Figure 14) or synthetic cloth is wrapped around the structure at least twice. This screen is manufactured on site by the Mistry and is included in the quoted drilling cost. The bamboo is obtained from the client’s land, or nearby, resulting in the effective cost of the screen comprising only the string or wire and filter cloth. Such screen is said to last three years.



**Figure 11: Cutting of Bamboo Slats**



**Figure 12: Cutting the Bamboo “Doughnuts”**

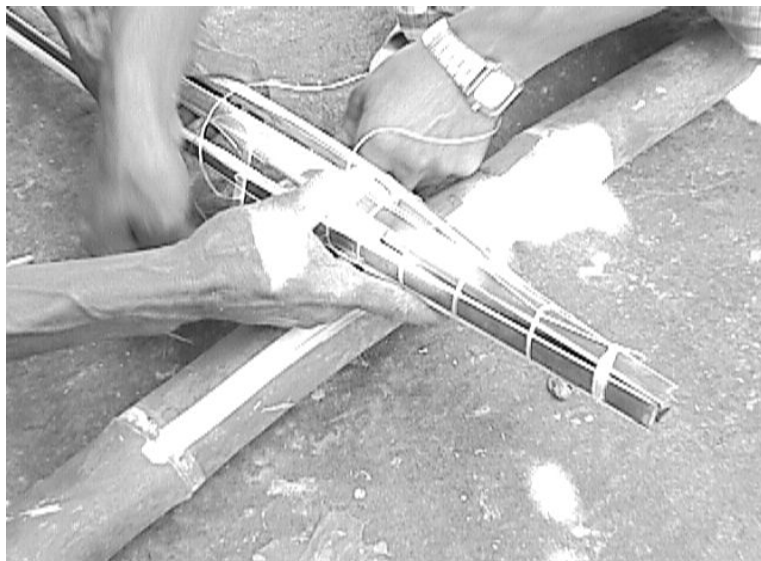

**Figure 13: Bamboo Screen Construction**



**Figure 14: Bamboo Screen Structure and Netting**



Alternatives are available in the hardware shops. 1½” galvanised pipes with large pressed out oval holes covered in fine brass mesh and brass sheet (Figure 15). This is mainly used for government funded No 6 Hand pumps installations.



**Figure 15: Screen formed from Galvanised Pipe with Pressed out Holes Covered in Brass Sheet**

Thin white polythene pipe 48mm OD 2.4mm wall is also available with machined pinholes of approximately 0.4mm diameter. There are 100 holes per circumference and 400 rows per metre. Note that conventional slotted PVC pipe is not in evidence.

Casing material is either PVC or Bamboo. The preferred species of bamboo is fast growing with a long distance between the knuckles and contains minimum pith. Bamboo of suitable diameter and length is cut, and the centre is cleaned with a steel, rhomboidal shaped flat face (Figure 16) which is fitted to a long ½” steel reinforcing bar and hand crank. The cleaning process is shown in Figure 17.



**Figure 16: Bamboo Cleaning Tool**



**Figure 17: Cleaning the Pith out of the Bamboo**

The bamboo lengths are joined by cutting sockets and allowing the bamboo to slip together. The casing is made leak proof by stretching a strip of old rubber inner tube over the joint.

All wells in the area are direct suction, with the pumps mounting directly onto the well casing. Thus conventional methods of dipping water levels during pumping would be difficult to achieve without installing dip tubes.

Figure 18 illustrates the flow from a 3" diesel pump which has been installed on to a sludged borehole.



**Figure 18: Flow from an Installed 3" Diesel Pump**

## **COST**

In direct comparison with hand auger equipment, the cost of the sludging rig is minimal. The mistries mobilise on a pair of bicycles, and have no need for a tripod, lifting equipment or temporary casing. The most expensive part of the investment is the 1½” boring tubes.

In North India, sludging is a very low cost drilling method. A 12m hole with fabricated bamboo screen is a comfortable day’s work for team of 2 costing the client 200 rupees (£3–4).

## **EQUIPMENT CAPABILITIES**

The method is used to drill sands, silt and clay. No specific tooling is used or spoken of in order to deal with sticky clay, which apparently would be sludged up in small lumps and washed clear. There is plenty of evidence of local brick making and pottery in the area to assume that clay is present locally. The sludging method is not suitable for hard materials, and drilling is stopped whenever anything hard is encountered such as a hard layer, boulders or large gravel.

## **CONCLUSIONS AND IMPLICATIONS FOR THE LOW COST DRILLING PROJECT**

The visit to Cooch Bihar indicates that Indian sludging is a very low cost drilling method which uses minimal equipment and is well entrenched into the private sector in North West Bengal. The technique as it stands is considered to be suitable for application to the soft formations in Uganda/Sub-Saharan Africa.

Observations of the sludging technique have illustrated a number of practical issues for the LCD technology.

- The cuttings can be successfully removed from the base of the hole with high flow rates up the drill pipe. The drill stem has a drive shoe attached to the base which fits closely to the inner surface of the borehole. It is likely that the fit of the shoe increases the flow up the drill pipe by restricting flow past in the annulus, thus forcing the water up into the drill pipe. In order to successfully utilise the sludging technique and obtain the required flow to remove the cuttings, the effect of the drill shoe should be analysed.
- The suction head is kept to a minimum by alternating between 1.5 and 3m pipe lengths at the surface. This may enable higher flowrates to be reached than sludging which uses 3m pipe lengths only. However, the main obvious advantage of alternating pipe lengths is the lack of need of a scaffold structure in order to reach the top of the pipe.
- The holes are kept flooded throughout the sludging process. The cost of this is borne by the client, who supplies the water throughout. The drilling observed took place just after the rainy season, when there are still sufficient quantities of pooled water which can be utilised. The question of supplier and water source in the context of Uganda/Sub-Saharan Africa needs to be analysed and addressed in collaboration with communities, farmers and contractors.

- The overall cost of the completed well in soft formations at £3-4 is very low. As well as low labour costs, and exclusion of the cost of fetching water, this also reflects the locally made, low cost screen and casing. In order to push down costs in Uganda/Sub-Saharan Africa, alternatives to traditional PVC screen and ready made casing should be investigated. Furthermore, it should be noted that as soon as rock is encountered, the penetration rate will be reduced considerably. This will increase the drilling time and require stronger rock drilling tools.
- Measurements have shown approximate work output levels for the lever operator and illustrate the need for additional human power, or mechanical advantage as the drilling penetrates deeper into the ground.
- The restriction of the equipment to soft formations highlights the need to undertake further study and practical work in drilling through harder materials with this technique.
- The measurement of penetration rates achievable in Cooch Bihar provides a comparison for drilling in similar soft materials in Uganda.