

Report on the investigation of the fire on board

HSS Stena Explorer

entering Holyhead

20 September 2001

Marine Accident Investigation Branch
First Floor
Carlton House
Carlton Place
Southampton
United Kingdom
SO15 2DZ

**Report No 5/2003
February 2003**

Extract from
The Merchant Shipping
(Accident Reporting and Investigation)
Regulations 1999

The fundamental purpose of investigating an accident under these Regulations is to determine its circumstances and the cause with the aim of improving the safety of life at sea and the avoidance of accidents in the future. It is not the purpose to apportion liability, nor, except so far as is necessary to achieve the fundamental purpose, to apportion blame.

CONTENTS

	Page
GLOSSARY OF ABBREVIATIONS AND ACRONYMS	
SYNOPSIS	1
SECTION 1 - FACTUAL INFORMATION	3
1.1 Particulars of <i>Stena Explorer</i> and accident	3
1.2 Background	4
1.3 Narrative	4
1.4 Cause of the fire	8
1.5 Failure of the fuel oil pipe	8
1.6 Lubricating oil storage tank	12
SECTION 2 - ANALYSIS	13
2.1 Aim	13
2.2 Cause of fuel pipe failure	13
2.3 Maintenance of the compression fittings	15
2.4 Use of compression fittings	20
2.5 Lubricating oil storage tank	21
2.6 Effectiveness of the response to the emergency	21
SECTION 3 - CONCLUSIONS	22
3.1 Causes and contributory factors	22
3.2 Other findings	22
SECTION 4 - SAFETY ACTION TAKEN BY STENA LINE	23
SECTION 5 - RECOMMENDATIONS	25

GLOSSARY OF ABBREVIATIONS AND ACRONYMS

BMT	:	BMT Edon Liddiard Vince Limited, London
CCTV	:	Closed circuit television
Water Hi-fog system	:	High pressure water fog fixed fire-fighting system
HSS	:	High-speed ship
IMO	:	International Maritime Organization
Linkspan	:	The berth used by an HSS. The vessel goes into the linkspan astern and is held in place by mechanical hooks ashore which engage in specially designed eyes on the vessel
MCA	:	Maritime and Coastguard Agency
MES	:	Marine Evacuation System
Olive	:	A small metal ring used in compression fittings. The olive is compressed when the fitting is tightened, deforming itself and the pipe to form a seal and mechanical stop on the pipe.
PA	:	Public Address System
VHF	:	Very High Frequency

SYNOPSIS



Stena Explorer is a high-speed catamaran capable of carrying up to 1500 passengers and 375 cars or freight at 40 knots.

The incident happened when the vessel was entering Holyhead harbour on 20 September 2001. There were 551 passengers on board and 56 crew. Visibility was good, the wind was 12 to 14 knots north-westerly and the sea state was calm in the sheltered waters.

At 1800, as she was proceeding astern, about 350m from the linkspan, the fire alarm sounded, indicating a fire in the port auxiliary engine room.

About 30 seconds after the fire alarm sounded, the vessel's entire CCTV system failed. Normally, the master used images from the CCTV cameras mounted on the stern, to position the vessel on the linkspan.

The chief engineer activated the water Hi-fog fire-fighting system in the area of the fire and requested permission from the master to shut down the port pontoon. However, the master decided not to do this until the vessel was fully lined up into the approach to the linkspan.

At 1806, the vessel was secured in the linkspan, and the passengers were evacuated safely and efficiently. The fire brigade attended 10 minutes later and, on the request of the fire chief, non-essential personnel were evacuated. At 1848, the fire brigade confirmed that the fire was extinguished.

The fire was caused by the failure of a compression fitting on an element of the fuel piping of the aft generator in the port pontoon. This failure allowed gas oil to be pumped out over the running engine, where it came into contact with the exposed hot surface of the engine's turbo-charger unit, and was ignited.

The accident highlights the dangers associated with the continued use of compression fittings in the fuel systems of diesel engines.

The failure of the CCTV system, and the issues surrounding headcounting procedures, have been addressed by Stena Line as a result of its own investigation into the fire.

A plastic free-standing lubricating oil storage tank was noticed during the investigation. A recommendation regarding this tank's compliance with the regulations has been made.

Further recommendations have been made with regard to the continued use of compression fittings in fuel lines of diesel engines.



Stena Explorer

SECTION 1 - FACTUAL INFORMATION

1.1 PARTICULARS OF *STENA EXPLORER* AND ACCIDENT

Vessel details

Registered owner	:	Stena Ferries Ltd
Manager(s)	:	Stena Line Ltd
Port of registry	:	London
Flag	:	United Kingdom
Type	:	Ro-ro cargo/ferry high-speed catamaran
Built	:	1996 Finnyards Oy, Rauma, Finland
Classification society	:	Det Norske Veritas A/S
Construction	:	Aluminium alloy
Length overall	:	126m
Gross tonnage	:	19,638
Engine power and/or type	:	4 GE Marine Gas Turbines geared to screw shafts 67975shp
Service speed	:	40 knots
Other relevant info	:	Bow thrusters, twin screw etc

Accident details

Time and date	:	1700 UTC on 20 September 2001
Location of accident	:	Entrance to Holyhead harbour
Persons on board	:	607
Injuries/fatalities	:	None
Damage	:	Limited to the immediate vicinity of the fire

1.2 BACKGROUND

Stena Explorer is a high-speed catamaran, capable of carrying up to 1500 passengers and 375 cars or freight at 40 knots. The vessel has been running on the Holyhead to Dun Laoghaire route since 1996, providing a minimum of three crossings a day, weather permitting.

The incident happened when *Stena Explorer* was entering Holyhead harbour at the end of her second return crossing from Dun Laoghaire on 20 September 2001. On board were 551 passengers and 56 crew. Visibility was good, the wind was 12-14 knots north-westerly, and the sea state was calm in the sheltered waters.

1.3 NARRATIVE

All times are UTC plus 1 hour.

On 20 September 2001, *Stena Explorer* made her usual north-westerly approach towards Holyhead harbour. She swung round off the Dolphin beacon light, east of the Admiralty pier, and then proceeded astern and through the harbour entrance towards the berth. At 1800, as she was making the turn round the corner at the end of the public quay (**see Figure 1**), about 350m from the linkspan, the fire alarm sounded. This indicated a fire in the port auxiliary engine room.

The chief engineer told the master immediately that he could see a fire on No 3 generator in the port pontoon, on the CCTV. **Figure 2** shows part of the port pontoon and No 3 generator. The navigator informed port control by radio, and requested the fire brigade to attend the vessel on arrival. Passengers were just starting to make their way towards their vehicles at the time of the fire alarm.

Since the vessel does not have bridge wings, and is navigated and manoeuvred from a central control position, the master uses the images from CCTV cameras to confirm the vessel's position on the electronic chart. This position is further confirmed, when entering the linkspan, by lookouts stationed aft giving distances off the linkspan. This was the procedure being followed on the day of the incident. However, about 30 seconds after the fire alarm sounded, the vessel's entire CCTV system failed. The master informed the navigator that he intended to continue his approach without the CCTV, by looking astern, using known transits and lines, and using lookouts stationed port and starboard aft.

Using VHF hand-held radios, the lookouts were able to guide the master into the berth by informing him how far *Stena Explorer* was from the linkspan fenders. This procedure is practised regularly with the CCTV in service, but this was the first time the master had berthed with the CCTV malfunctioning.

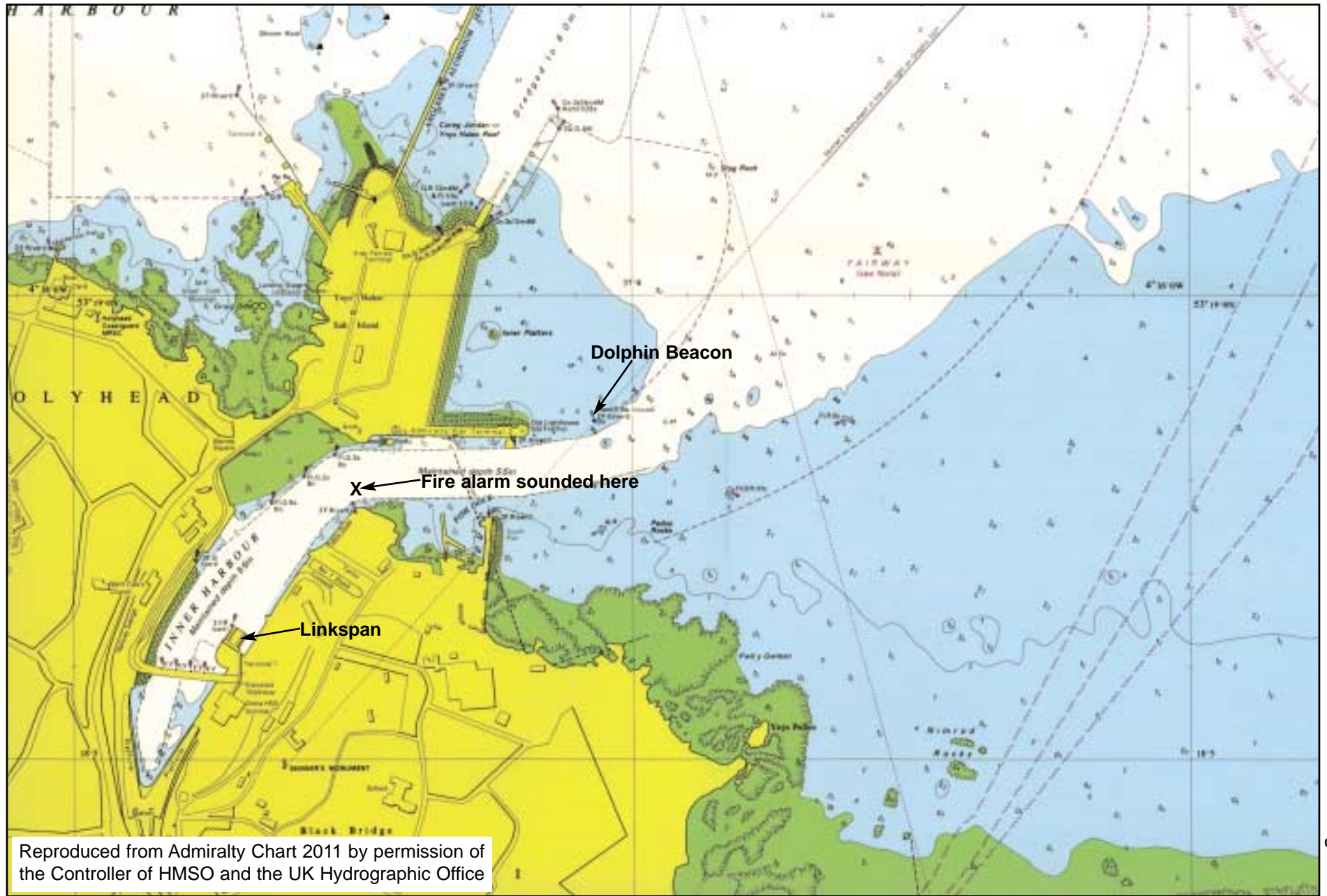

Reproduced from Admiralty Chart 2011 by permission of the Controller of HMSO and the UK Hydrographic Office

Figure 1

Figure 2

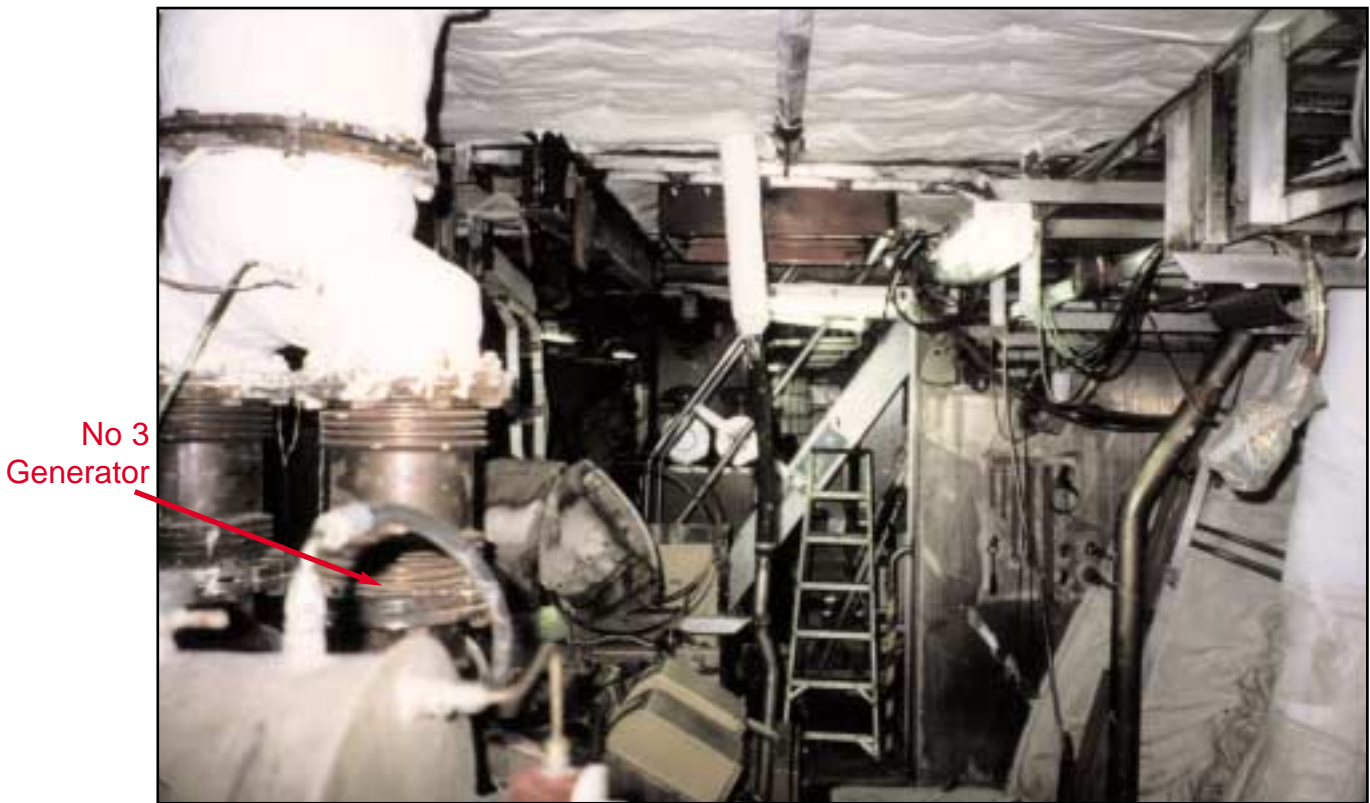

No 3
Generator

Port pontoon

Figure 3



Hi fog head above generator No 3

The chief engineer activated the water Hi-fog fire-fighting system in the area of the fire at 1802. (**Figure 3** shows the Hi-fog head above generator No 3.) He requested the master's permission to shut down the port pontoon. The master, however, decided not to do this until the vessel was fully lined up with the approach to the linkspan. This decision was based on the following conditions:

- *Stena Explorer* was in severely restricted waters with only about 20m of water either side of her. Should an evacuation have become necessary, this would have made deploying the vessel's MES difficult.
- The close proximity of the linkspan, and the safety to passengers and vessel provided by being securely alongside.
- The prior knowledge, from the pre-arrival checks, that all the watertight doors were shut. This gave the vessel a minimum of 60 minutes fire protection. The vessel would be berthed in about 5 minutes.
- Anchoring would have been precarious because of the close proximity of land, the wind, and potentially having only one pontoon in operation.

The master decided not to muster the fire-fighting party until the vessel was alongside, because two of the fire-fighting party were assisting in guiding the vessel on to the linkspan, and others were needed at berthing stations.

Then, smoke started coming from the port side of the vessel and was blown across the weather deck, fully obscuring everything aft of the mainmast. The deck supervisor continued to give distances off the fender and the linkspan. When the vessel was fully lined up to the linkspan, and about 2m off it, the master instructed the chief engineer to shut down the port pontoon. This was done at 1804.

The master released the navigator, who had been assisting him with the approach to the berth, to make announcements to the passengers, and to the crew mustering the working parties and preparing to evacuate the vessel.

At 1806, *Stena Explorer* was secured in the linkspan. The navigator notified the coastguard of the situation by telephone, before leaving the bridge to assist with the evacuation. The master and the chief engineer remained on the bridge.

The deck supervisor decided to clear the first few occupied cars through the stern door, so as to evacuate passengers as quickly as possible, and create sufficient space for the fire brigade to board the vessel. The working parties, and announcements, instructed all remaining passengers to leave on foot.

The fire brigade attended with two appliances, arriving at 1816.

Passengers are limited to a single deck on board *Stena Explorer*. By 1821, two full searches of this deck had been made, to ensure none remained on board.

However, the number of passengers leaving the vessel was not checked on board. These were counted ashore in the embarkation lounge, but those who had been allowed to drive off in their cars were not counted.

While the passenger spaces were being searched, fresh water was taken on board to replenish that used by the water Hi-fog system.

At 1825, the fire chief requested that non-essential personnel be evacuated. This was achieved by 1830. The fire brigade then entered the port auxiliary engine room space. The water Hi-fog system was deactivated on the request of the fire brigade. They confirmed that the fire was extinguished at 1848.

The chief officer, chief engineer, and the fire chief then carried out a full survey of the port pontoon. At 1917, they reported to the master that the situation was safe enough for the passengers to return on board to collect their property and vehicles.

At 1930, all passengers and vehicles were clear of the vessel.

1.4 CAUSE OF THE FIRE

The fire was caused by an element of the fuel tubing on the aft generator in the port pontoon (No 3 generator) coming loose and being blown clear of the engine. This then allowed gas oil, at a pressure of 10.2 bar, to be pumped out of the fuel manifold and over the running engine and surrounding area. This fuel came into contact with the exposed hot surface of the engine's turbo-charger unit, located above the leak, and was ignited. **Figure 4** shows the position of the turbo-charger relative to the position of the leak.

Stena has three HSS, all of which are fitted with four generators, powered by Cummins type KTA 38 KV12 engines. These had been routinely overhauled by Cummins Diesel.

1.5 FAILURE OF THE FUEL OIL PIPE

The diesel generator fuel oil system arrangement is illustrated in **Figure 5**. The high and low pressure pipes of the system, between the booster pump and fuel injectors, are joined together by flange or compression type fittings. The fitting which failed, resulting in leakage of oil, was a compression fitting on what is known as a pig-tail pipe, see **Figure 6**. The pipe was on the low pressure side, between the booster pump and high pressure pump, and was one of four connecting the forward and aft, upper and lower, fuel rails for each bank of cylinders in the 'V' configuration engine. This is shown in **Figure 7**.

A dismantled pig-tail, showing the components of the compression fittings, can be seen in **Figure 8**. The steel olive provides support to the rubber seal, and bites into the steel pipe securing the fitting to it. However, these olives cannot provide the seal because they are not solid, but are of sprung construction. In the more common design of compression fitting, a solid metal olive is used. This is deformed by the tightening of the nut, causing it to bite into the wall of the pipe, securing it to the pipe and forming the seal.

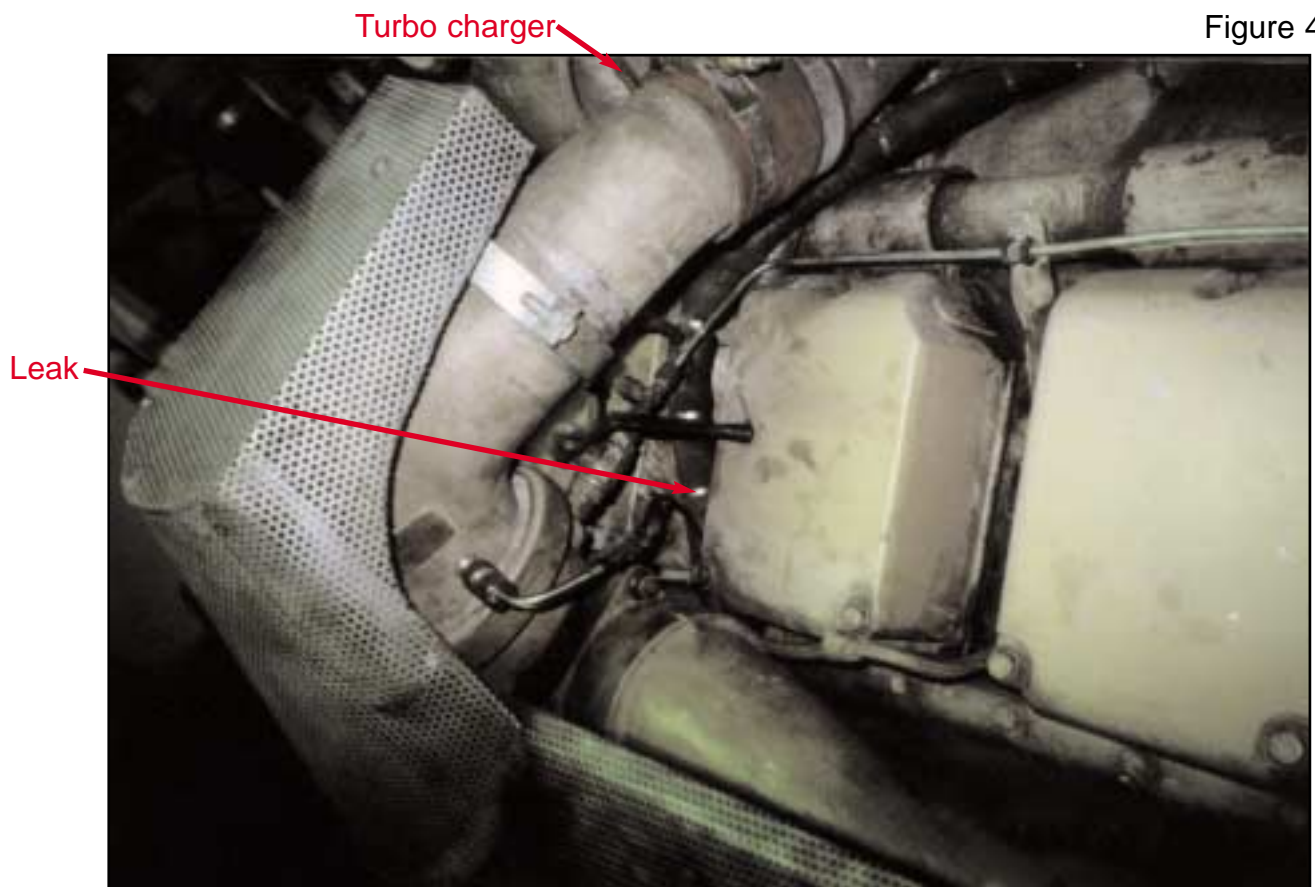
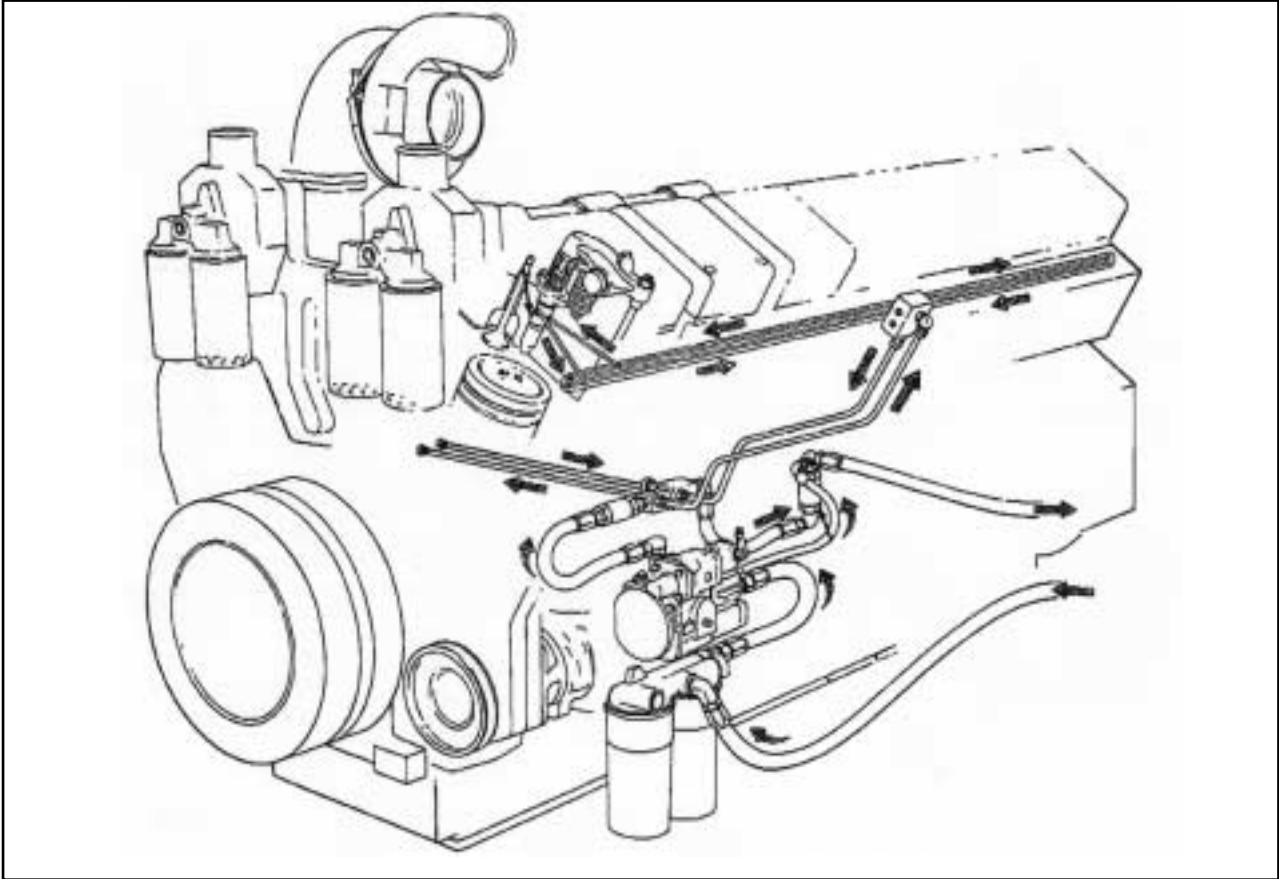

Figure 4

Position of turbo charger relative to leak

Figure 5



Engine fuel oil system arrangement

Figure 6

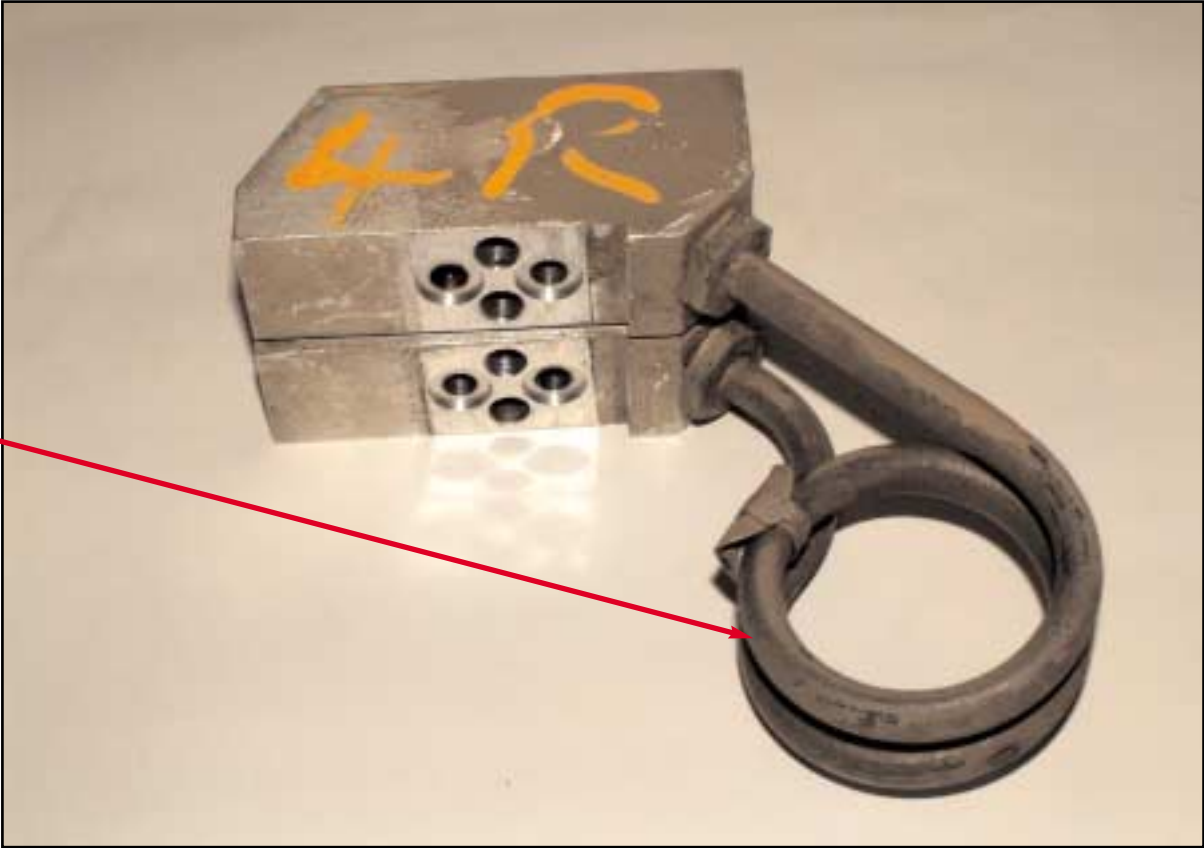

Pig-tail pipe

Fuel block and pig-tail pipe

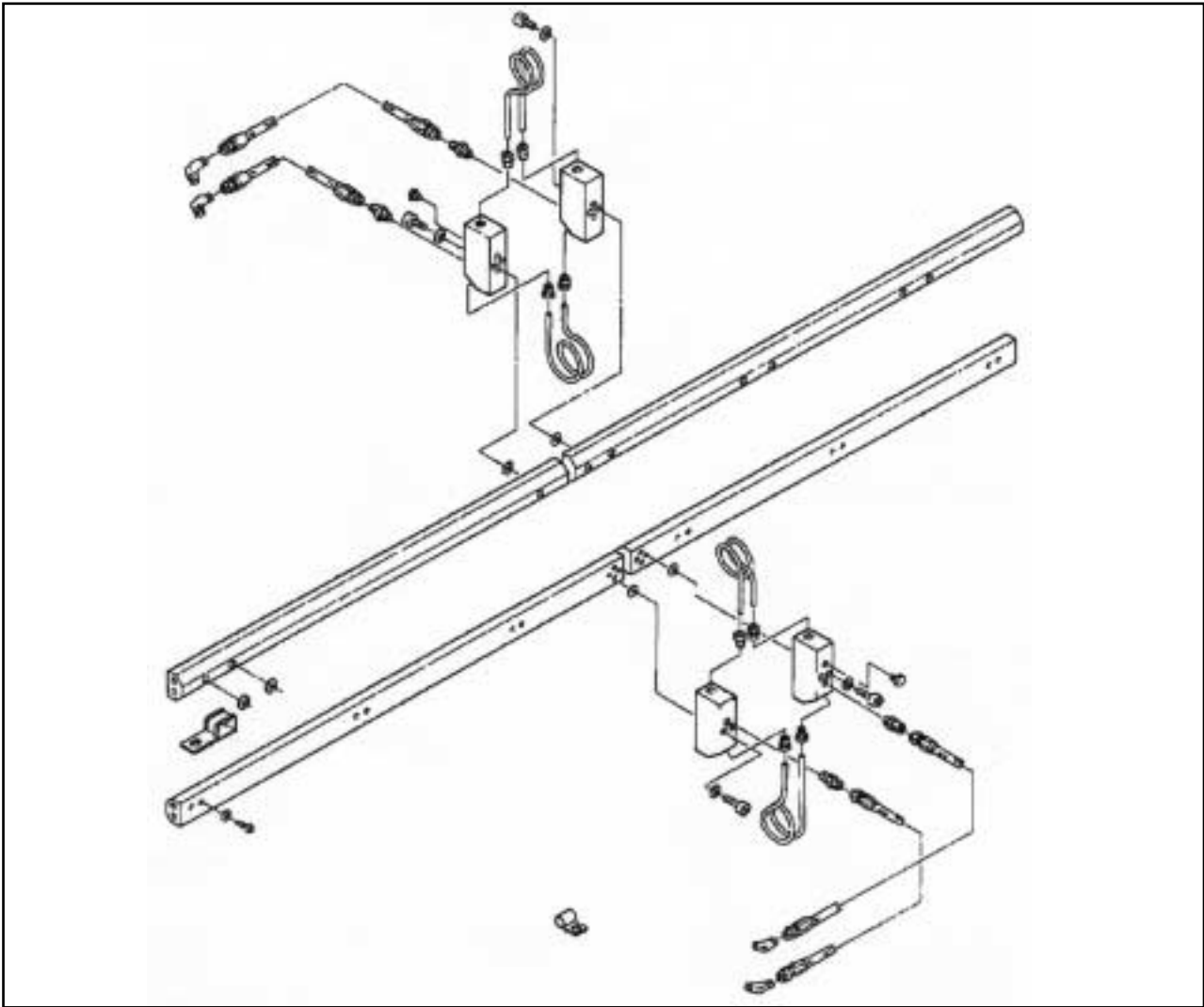

Current fuel plumbing

Figure 8

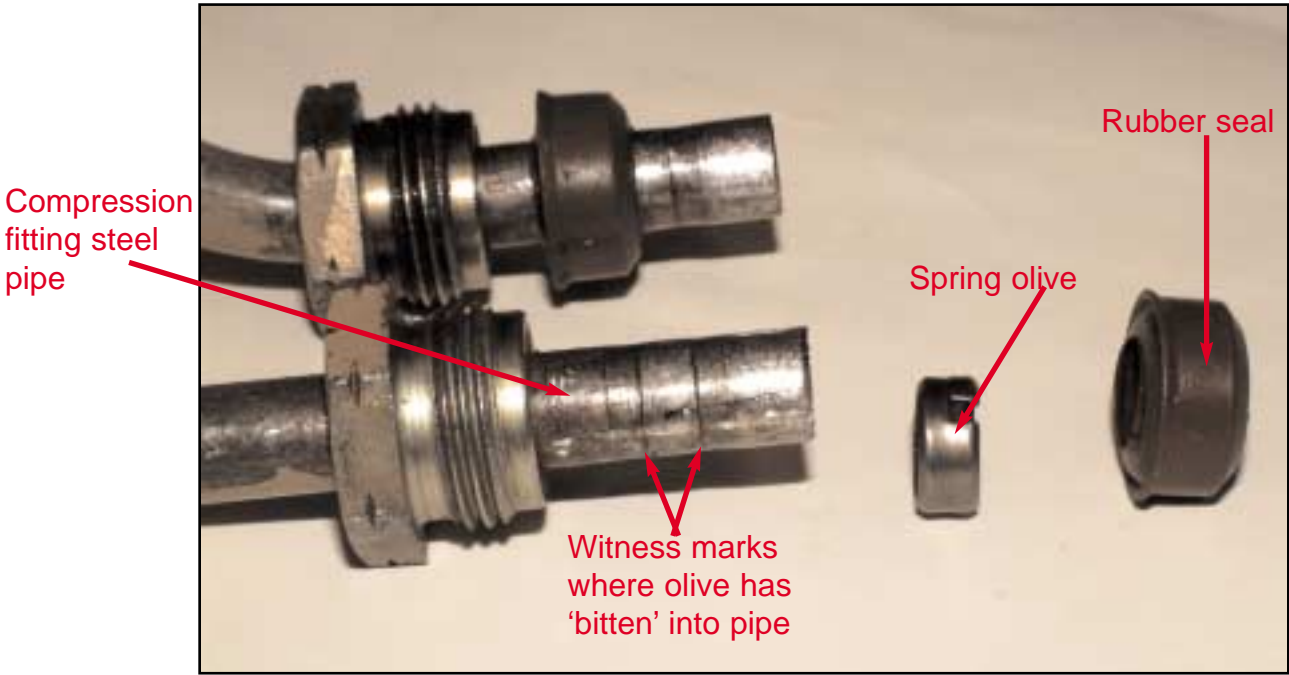

Compression fitting components of dismantled pig-tail

1.6 LUBRICATING OIL STORAGE TANK

While inspecting the scene of the fire in the auxiliary engine room in the port pontoon, the MAIB inspector noticed a free-standing lubricating oil storage tank of plastic (Polystone G) construction. The tank can be seen in **Figure 9**.

The International Code of Safety for High-Speed Craft, paragraph 7.5.2 states:

“Fuel tanks should not be located in or contiguous to areas of major fire hazard. However, flammable fluids of flashpoint not less than 60°C may be located within such areas provided the tanks are made of steel or other equivalent material.”

The auxiliary engine room is an area of major fire hazard, and there was no documentary evidence to show that the material used was considered an equivalent to steel.

The code defines “steel or other equivalent material” as meaning “any non-combustible material which, by itself or due to insulation provided, has structural integrity properties equivalent to steel at the end of the applicable exposure to the standard fire test” (paragraph 7.2.6).

The tank has been on board since the vessel was built. The vessel has been surveyed a number of times in the last 6 years.

Figure 9

Freestanding
lubricating oil
storage tank



SECTION 2 - ANALYSIS

2.1 AIM

The purpose of the analysis is to determine the contributory causes and circumstances of the accident as a basis for making recommendations to prevent similar accidents in the future.

2.2 CAUSE OF FUEL PIPE FAILURE

The Cummins workshop manual instructs fitters to install the pig-tail pipes in the following stages:

- *The pig tails must be installed on the fuel blocks before these are fitted to the engine.*
- *The ends of the pig tail pipes are to be pushed as far as possible into the fuel blocks, and the compression fitting installed but not tightened.*
- *The fuel block assemblies are now bolted to the fuel manifolds on the engine.*
- *The compression fitting nuts should then be tightened up using only fingers until the nut touches the compression sleeve and the compression sleeve touches the counterbore in the fuel block (see Figure 10).*
- *The nuts should now be fully tightened using a spanner. For 5/8 inch (16mm) hex nuts, the nut should be tightened $\frac{3}{4}$ to 1 full turn. For 11/16 inch (17.5mm) hex nuts the nut should be tightened until the bottom of the hex touches the fuel block.*

Subsequent examination of the failed pig-tail, showed that it had not been pushed as far as possible into the fuel block before it was tightened. Only one half of the steel olive had bitten into the pipe, so the compression of this olive was incomplete, and was not enough to provide adequate purchase on the pipe.

Since the olives in these fittings were sprung in construction (see Figure 11), the fitting was sealed by compressing the rubber element between the pipe and the fuel block counterbore. As a result, it is probable that it would still have provided a full seal against fuel leakage, even though the pipe was not correctly fitted when it was last overhauled. This condition could have given the impression that the pipe had been correctly fitted. In fact, it was in danger of blowing out at any time.

Figure 10

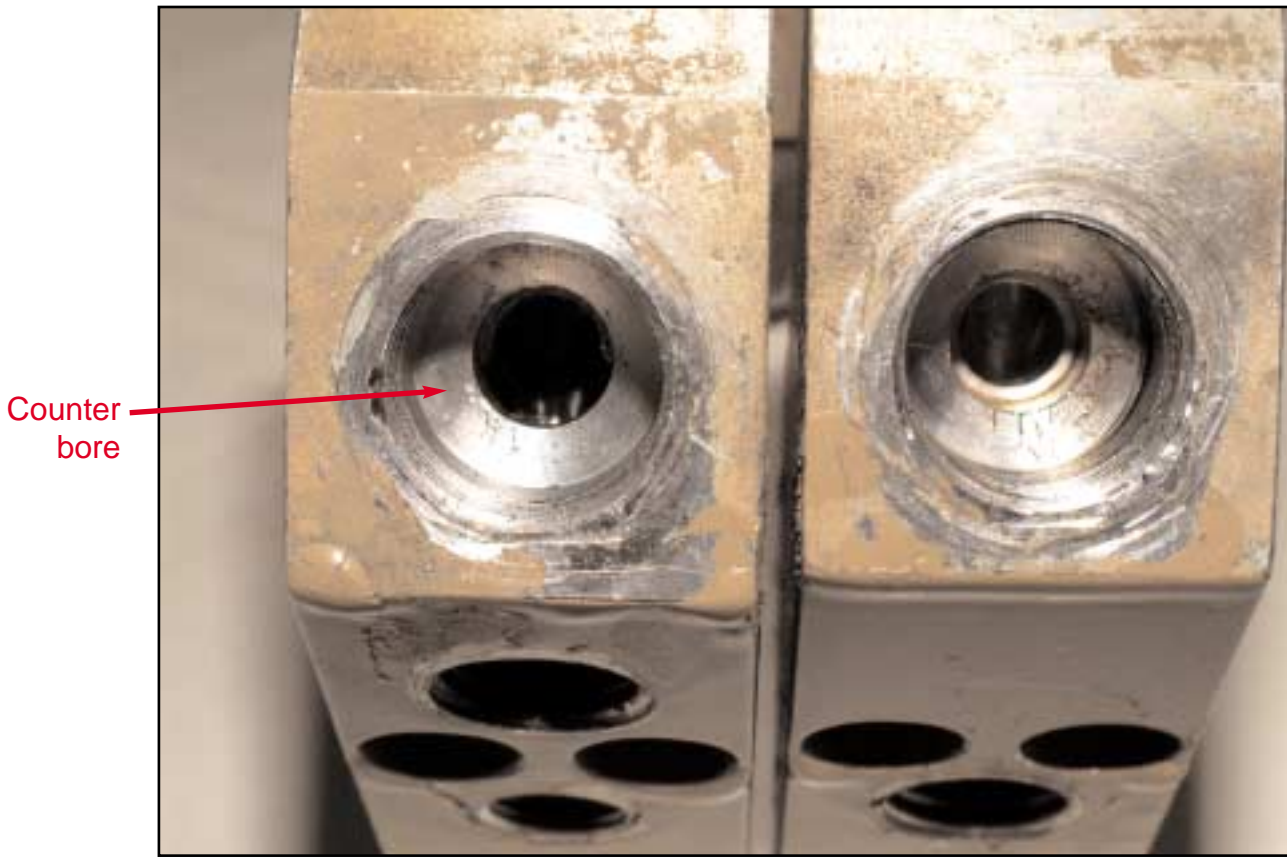

Fuel blocks

Figure 11

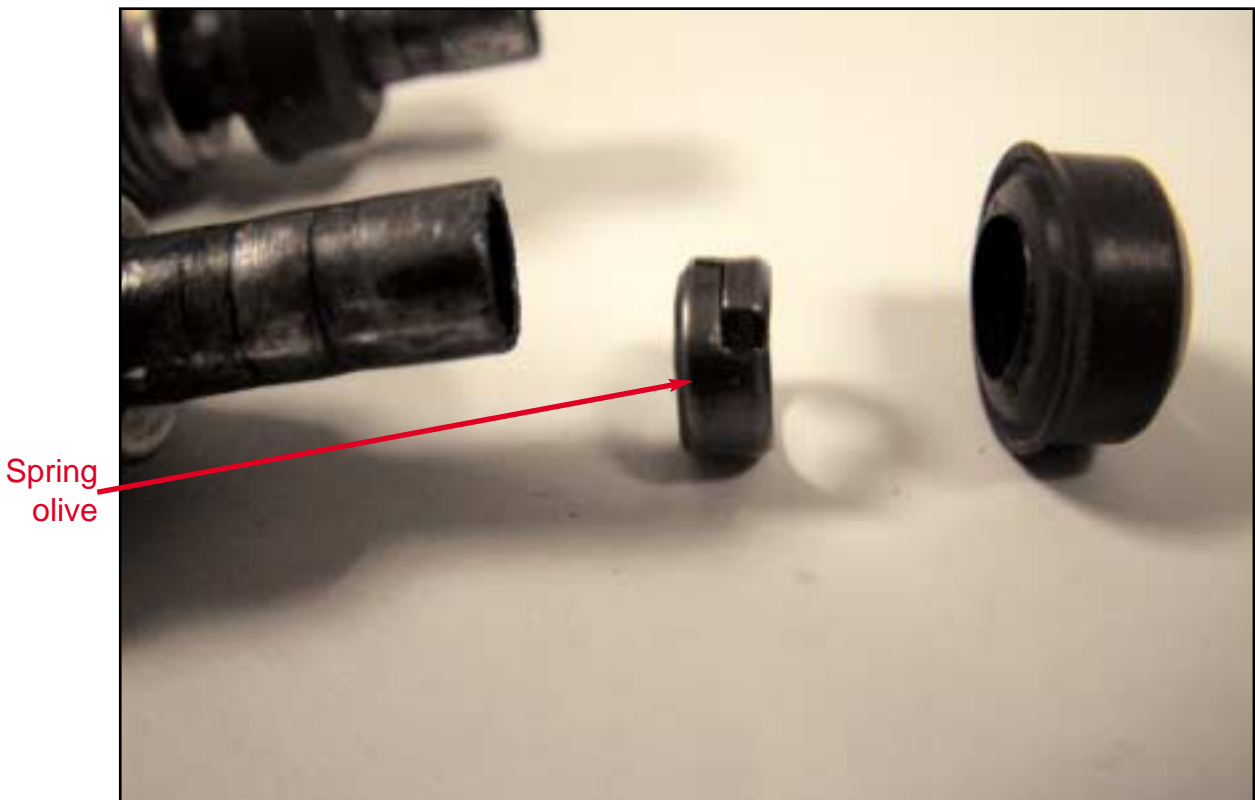

2.3 MAINTENANCE OF THE COMPRESSION FITTINGS

The compression fittings on these pig-tail pipes are changed depending on their condition at overhaul. They are not changed as a matter of routine, as part of the planned maintenance system for the engines. This particular engine was last overhauled about 14 months before the accident. As with every overhaul since the engines were fitted, Cummins Diesel carried out this overhaul. There are no records to indicate that an adjustment to the fittings had been made since then.

There was no way of ensuring that the pig-tail pipes were correctly fitted, without removing them for inspection. Because of their position on an engine in service, access is extremely restricted, and they cannot be easily seen.

Figures 12 and 13 show lower pig-tail pipes in position on a similar engine at Cummins Diesel in Wellingborough (note that this type of engine is not fitted with upper pig-tails) and on an engine on board *Stena Explorer*.

Removal and refitting of these pipes cannot be done without first removing the fuel blocks from the engine.

With the pig-tail fittings used there, the olive springs free of the pipe when the fitting is disconnected. This makes it impossible to check the security of the compression fitting.

In the more common design of compression fitting, using a metal olive, the olive is deformed by tightening the nut, causing it to bite into the wall of the pipe. The olive is secured on the pipe and it forms a seal. It also acts as a mechanical stop, which secures the correct position of the pipe in the compression fitting.

However, unlike the pig-tail compression fitting, the position of the olive on the pipe, together with the security of its deformation, can be checked by disconnecting the fitting and inspecting the olive. Even so, this type of compression fitting still requires careful assembly, and has proved, in past investigations of similar accidents, to be prone to leakage.

Figure 12

Lower pig-tail
on engine at
Cummins
Diesel,
Wellingborough

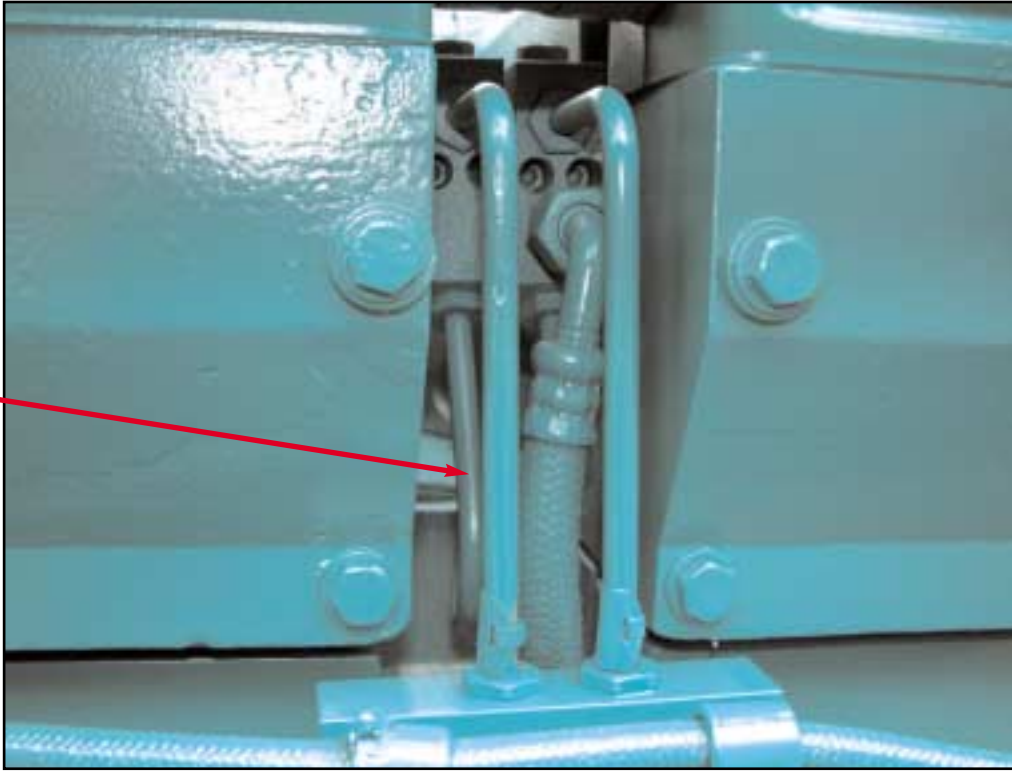

Figure 13

Lower pig-tail

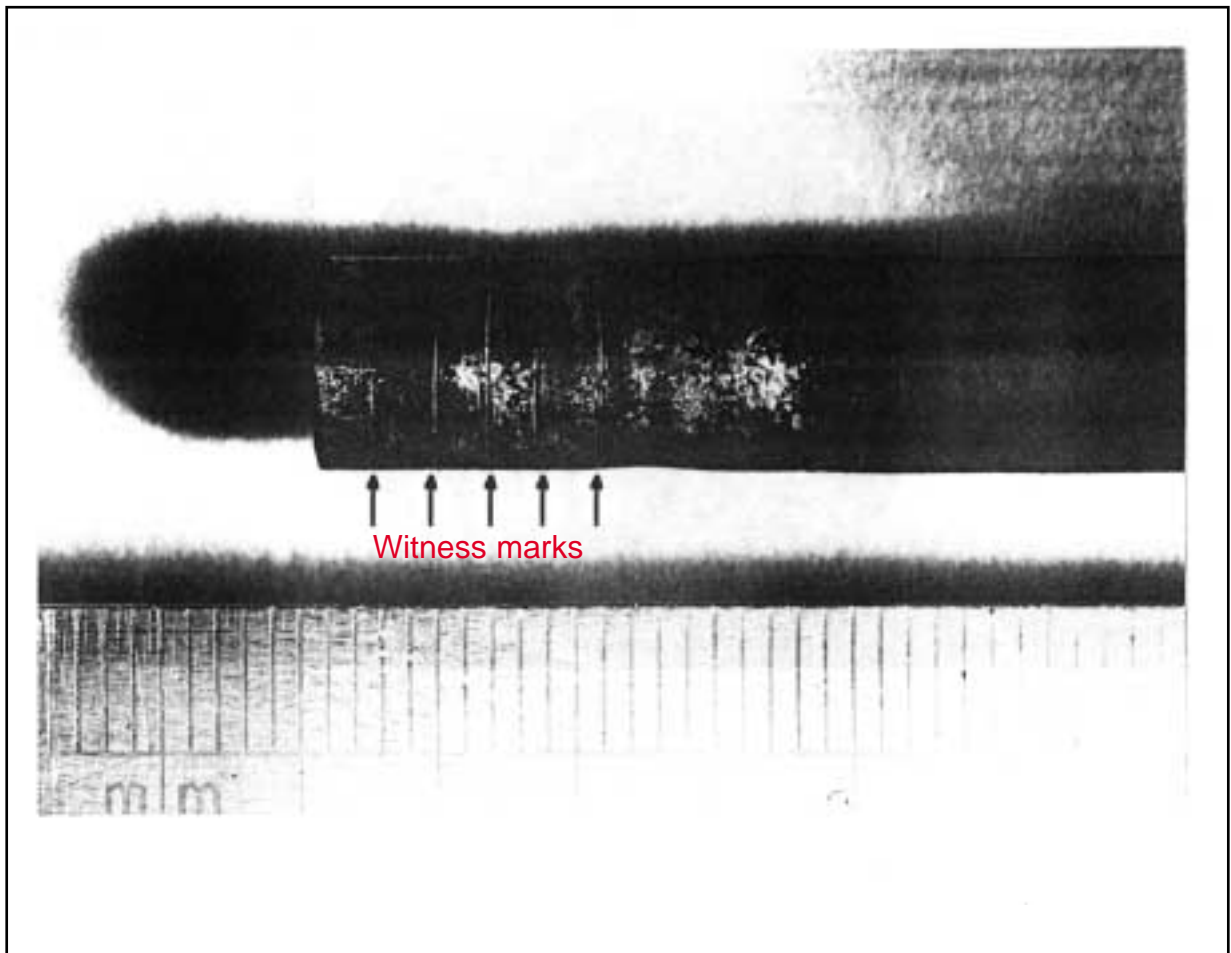

Figure 14 is taken from “Examination of failed fuel system component, ex *Stena Explorer*”, a report carried out by Atlantic Engineering after the accident. It shows five distinct witness marks in the end of the pig-tail pipe, which blew off the engine. The report concludes that the lowest of these is the single bite where the olive had gripped the pipe at the time of the accident.

The other four can only be explained by the olive being compressed on to the pipe in two different positions previously. Had the pipe been in the same position every time the fitting was tightened, there would only be two witness marks on it, from the top and bottom of the olive. This shows that the pipe could not have been pushed fully home before tightening on at least one previous occasion.

Cummins’s warranty database shows that, on two occasions, similar failures with pig-tail pipes have occurred. It states that thousands of these engines have been produced. However, its records only extend to engines serviced by Cummins Diesel, so the actual number of failures is unknown.

Figure 14



Pig-tail pipe end showing five witness marks

Taken from “Examination of failed fuel system component, ex *Stena Explorer*” by Atlantic Engineering

In the second quarter of 1994, Cummins introduced a change to the design of the fuel plumbing on all engines using the upper and lower pig-tail pipe connection system. *Stena Explorer* was fitted with the pre-1994 designed arrangement, and this is shown in **Figure 15**.

The design change involved replacement of the upper pig-tail with a further fuel manifold, and is shown in **Figure 16**. Cummins has stated that this was done to improve diagnostics on the engine.

Figure 15

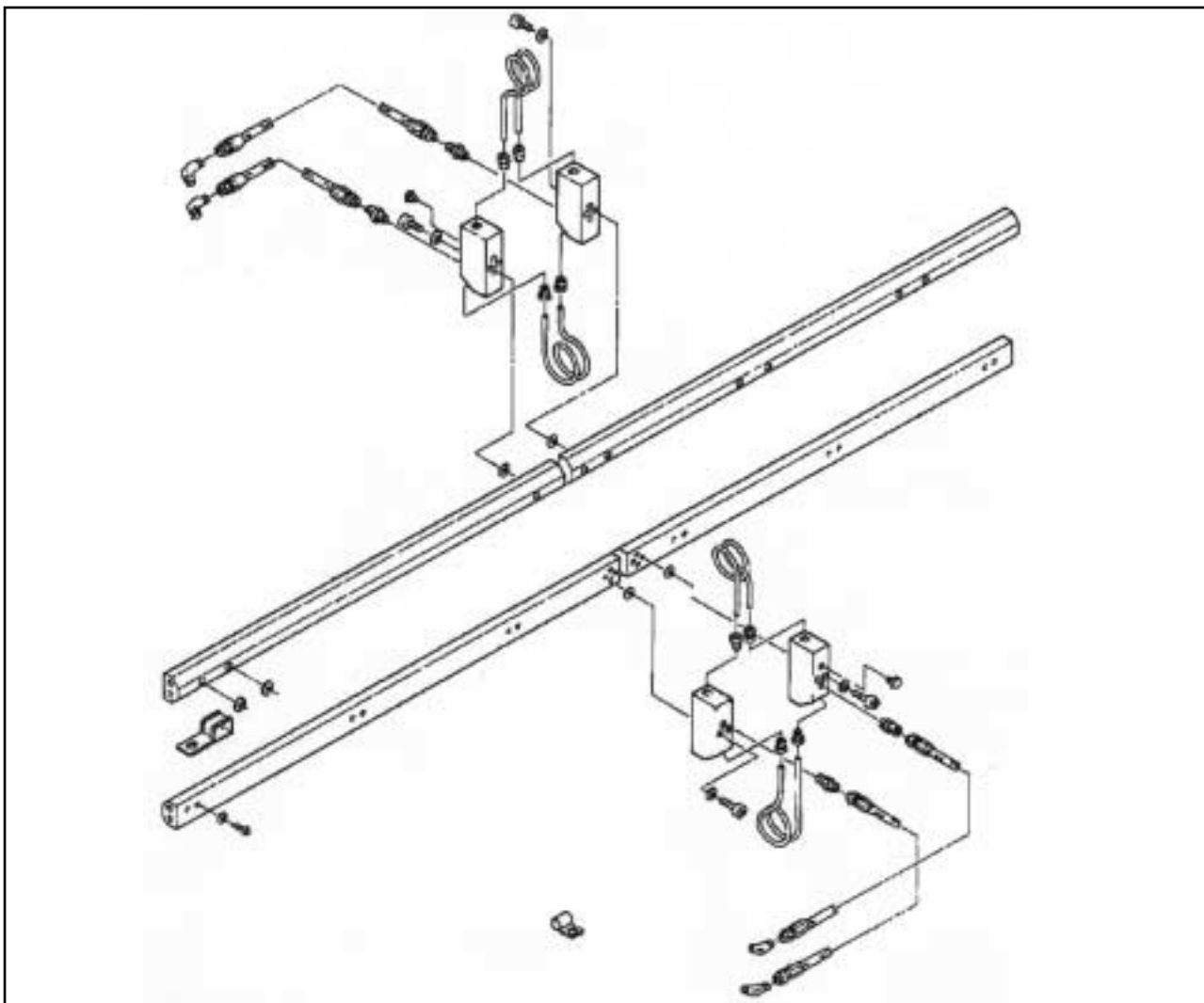

Current fuel plumbing

The risk of fuel spillage and fire using this design is reduced, but not eliminated. Stena Line has requested that Cummins retrofit this new design to the 12 engines affected in the Stena fleet. This will be done as part of the next planned overhaul of each engine. However, Cummins has stated that it will not advise its customers to modify engines which do not already bear the improved design. This is an unsatisfactory situation, and one which Cummins ought to reconsider.

Further, at the request of Stena Line, Cummins Diesel will make a gauge to facilitate an in-situ check of pig-tail pipes, to ensure that they are pushed as far as possible into the fuel blocks. It is not the intention of Cummins Diesel to supply this gauge to its agents, fitters or customers, other than Stena Line. It will not be illustrated in its workshop manual or parts catalogue.

Figure 16

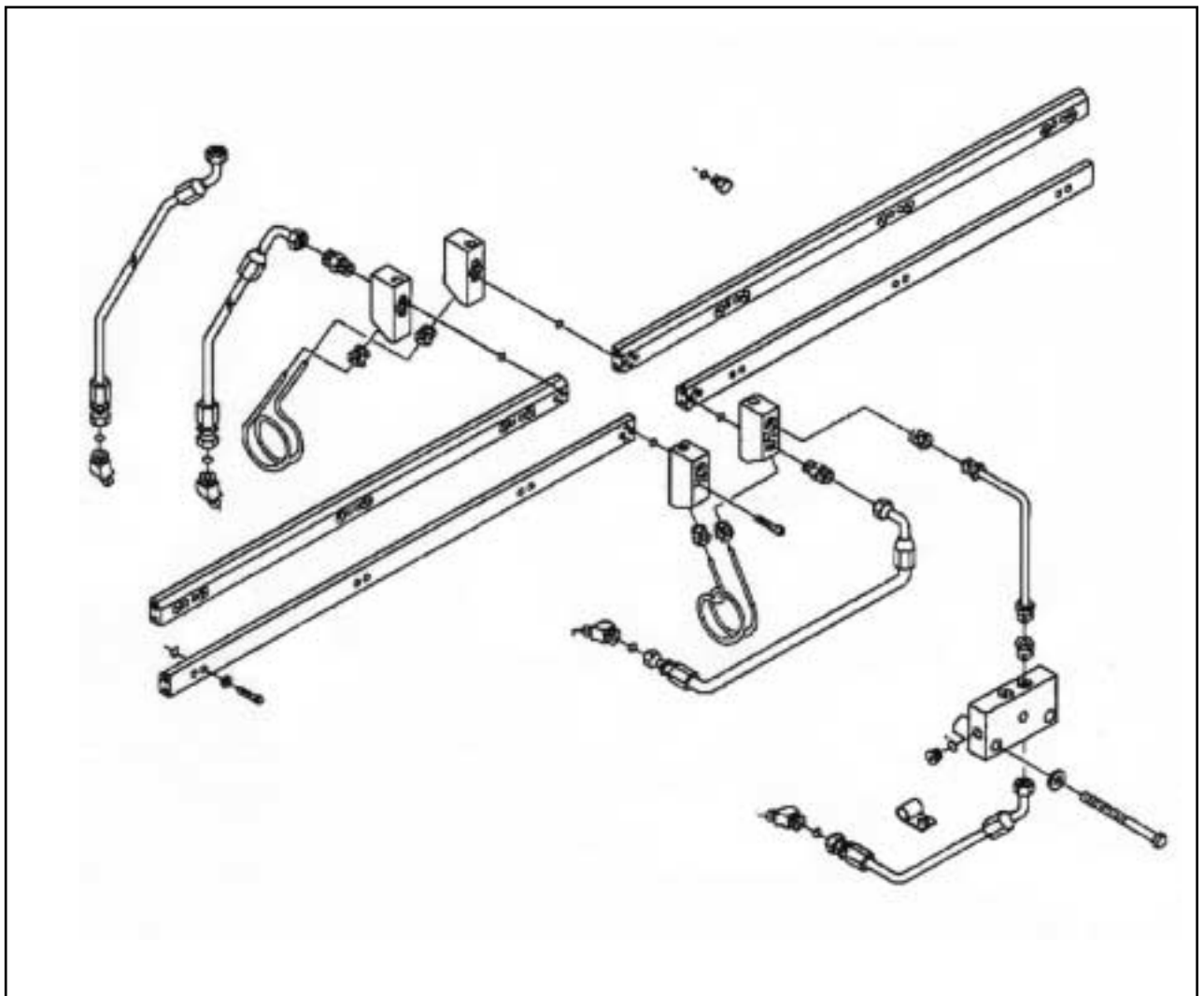

Proposed fuel plumbing

2.4 USE OF COMPRESSION FITTINGS

The fact that the security of compression fittings cannot be guaranteed, has led to much discussion at IMO safety committees about their suitability for use in fuel systems. However, the use of compression fittings is yet to be prohibited by the IMO, the MCA and the classification societies.

Before these discussions, and as a result of MAIB investigations into engine room fires caused by spillage of fuel oil on to hot machinery surfaces, MCA research project 401 of 1997, carried out by BMT, addressed "Failures of Low Pressure Fuel Systems on Ships' Diesel Engines". This report recommended (recommendation 14.3.4) that within 5 years:

"Regulations to prohibit the use of compression fittings in both low and high-pressure fuel systems should be considered. We recommend that this becomes a mandatory requirement, via submission to the IMO "

The MCA took the argument to the IMO. Although it accepted the dangers of fuel oil related fires, the IMO was unable to agree that compression fittings should be eliminated altogether. However, on 1 June 1998, it issued an information circular advising the wisdom of not fitting compression joints on diesel engine fuel oil supply lines. The circular states:

"Experience indicates that compression couplings require careful attention to tightening procedures and torques to avoid leaks or damage to the pipe when subject to overtightening. They should not be used in the fuel supply line of the injection pumps and spill system. Flanged connections should be used in place of compression couplings." (IMO MSC/Circular 851, "Guidelines on engine-room oil fuel systems", Annex 3.6).

On 1 July 2002, the IMO amended SOLAS Chapter II-2 regulation 4.2.2.5.4. This reads:

"Connections within the fuel supply and spill lines shall be constructed having regard to their ability to prevent pressurised oil fuel leaks while in service and after maintenance"(SOLAS Chapter II-2 regulation 4.2.2.5.4)

This regulation does address fuel spillage, but does not specifically prohibit the use of compression fittings.

Compression fittings, therefore, continue to be allowed in diesel engine oil fuel lines. It is left to the wisdom of the owner and manufacturer whether or not they are fitted. Incorporating detailed instructions in the maintenance procedures, along with regular inspections, and shielding any possible spillage from hot surfaces, are safeguards to reduce the risk of an accident. However, only the elimination of compression fittings from the fuel lines in diesel engines will significantly reduce the risk of fire because of leakage.

Flanged joints can also provide leakage hazards, but less so than for compression fittings. The security of these joints can be more easily checked, and there is significantly less scope for them to be incorrectly assembled than in the case of compression fittings. They are also less susceptible to failure because of vibration and fatigue.

2.5 LUBRICATING OIL STORAGE TANK

It is uncertain whether or not the plastic lubricating oil storage tank fitted on board complies with the requirements of paragraph 7.5.2 of *The International Code of Safety for High-Speed Craft*. The safety certificate on board does not record that the plastic tank has been exempted from the code's requirements. The owners do not have any documented evidence to support an exemption.

It is the responsibility of the flag state to ensure that, if an exemption from an appropriate requirement is given, this fact is clearly documented and available for examination.

The MCA needs to examine whether or not the plastic, free-standing lubricating oil storage tanks installed on board *Stena Explorer*, and any of her sister vessels operating in UK waters, comply with the requirements of *The International Code of Safety for High-Speed Craft*.

2.6 EFFECTIVENESS OF THE RESPONSE TO THE EMERGENCY

The decisions made by the master, and the crew's response to the emergency were professional, timely, and brought a difficult situation quickly under control.

In 1987, after an investigation into a fire aboard one of its vessels, Stena Line introduced an engine room fire shutdown procedure. In this procedure, the engine room will call the bridge for permission to black out, immediately on activation of an engine room fire alarm. The procedure relies on the use of a dedicated engine room fire alarm which is activated manually, thus eliminating false alarms.

Immediate blackout of the engine room ensures that fuel and air supplies to the fire are stopped as soon as possible. This allows the fire to be brought under control quickly and, hence, maximises the effectiveness of subsequent fire-fighting.

In this incident, the master decided correctly that getting the vessel into the linkspan took priority over shutting down the port pontoon. He, therefore, refused the chief engineer's request to shut it down. This is the first instance since the introduction of this procedure where refusal has been necessary.

The water Hi-fog fire-fighting system proved its effectiveness. The fire was stopped very quickly, and there was little damage to the surrounding areas.

SECTION 3 - CONCLUSIONS

3.1 CAUSES AND CONTRIBUTORY FACTORS

1. The fire was caused by the failure of the compression fittings on a pig-tail pipe in the fuel system of the port No 3 alternator engine. [1.4]
2. The compression fittings failed because they had been incorrectly fitted at the last overhaul. [2.3]
3. No methods for checking were available to ensure that the compression fittings had been fitted correctly. [2.3]
4. Having compression fittings fitted to the diesel engine increased the likelihood of fuel oil leakage. [2.4]

3.2 OTHER FINDINGS

5. The CCTV system on board Stena Explorer suffered a complete failure as a result of the fire. [1.3, 4.1]
6. There was no headcount of passengers ashore to ensure that all had been accounted for. [1.3, 4.1]
7. A free-standing lubricating oil storage tank, in the port auxiliary engine room, was found to be constructed of a material other than steel. No documentation was available to show this tank's exemption from the requirements of The Code of Safety for High-Speed Craft. [2.5]

SECTION 4 - SAFETY ACTION TAKEN BY STENA LINE

4.1 SAFETY ACTION TAKEN BY STENA LINE

Stena Line recognised issues as a result of its own internal investigation, and these have led to corrective actions, which are now in place. These are described below.

The vessel's CCTV system

The CCTV failure was caused by the ship's entire CCTV system being supplied by a single power supply. When the fire damaged the cable supplying the camera in auxiliary engine room 3, the entire system was lost.

This power supply system has now been altered to provide two independent power supplies: one to the cameras and one to the CCTV camera control matrix. In the event of a power failure to the matrix, it can be hardwired to allow manual camera selection.

The camera power supply is further split into independent port and starboard supplies, such that a major fault on one side of the vessel will not break the electrical supply to the other side.

In addition, each of the four aft CCTV cameras, which display a view of the linkspan during berthing operations, is to be supplied by two independent power supplies. These will be taken from the port and starboard emergency lighting circuits, and will be capable of being switched manually.

In the event of a similar accident, the entire CCTV system will no longer be lost, and sufficient CCTV coverage, to enable safe operation of the vessel, will be maintained.

Headcounting procedure

There is no requirement for a headcounting procedure ashore, and there was no such procedure in place. This meant that a number of passengers were permitted to drive away without being counted.

Although searching a vessel to ensure that all passengers have disembarked is a useful safety procedure, a full headcount compared with the ship's passenger manifest is a more accurate method of ensuring that all have been accounted for. This should be carried out in a designated area ashore.

Stena has now included a passenger counting procedure in its port emergency plan, for every port used. The procedure describes a counting method and designated holding areas for passenger and vehicles. Stena Line also extends this service to vessels using the port as a port of refuge.

Fitting of the pig tail compression fillings

A gauge will be used on the pig-tail pipes, to facilitate checks to ensure that they are pushed as far as possible into the fuel blocks.

SECTION 5 - RECOMMENDATIONS

The Maritime and Coastguard Agency is recommended to:

1. Use the particulars of this accident, to press within the International Maritime Organization for the prohibition of compression fittings in fuel lines of diesel engines.
2. Remind all owners and operators of vessels under the UK flag to review their risk assessments in relation to insulating hot surfaces and screening fuel fittings, where compression fittings are used in diesel engine fuel lines.
3. Consider whether the plastic, free-standing, lubricating oil storage tanks installed on board *Stena Explorer*, and any of her sister vessels operating in UK waters, meet the requirements of *The International Code of Safety for High-Speed Craft*, or an equivalent level of safety.

Classification Societies are recommended to:

4. Remind all owners and operators under their jurisdiction, to review their risk assessments, and hence their policy, with regard to the use of compression fittings in diesel engine fuel oil lines, until regulation to prohibit the use of these fittings is in place.

Cummins Diesels are recommended to:

5. Supply to its agents, fitters and customers, a gauge to facilitate in-situ checks of pig-tail pipes, to ensure that they are pushed as far as possible into the fuel blocks.

Marine Accident Investigation Branch
February 2003