

### COMPONENTS OF WING CENTRE - SECTION JOINT

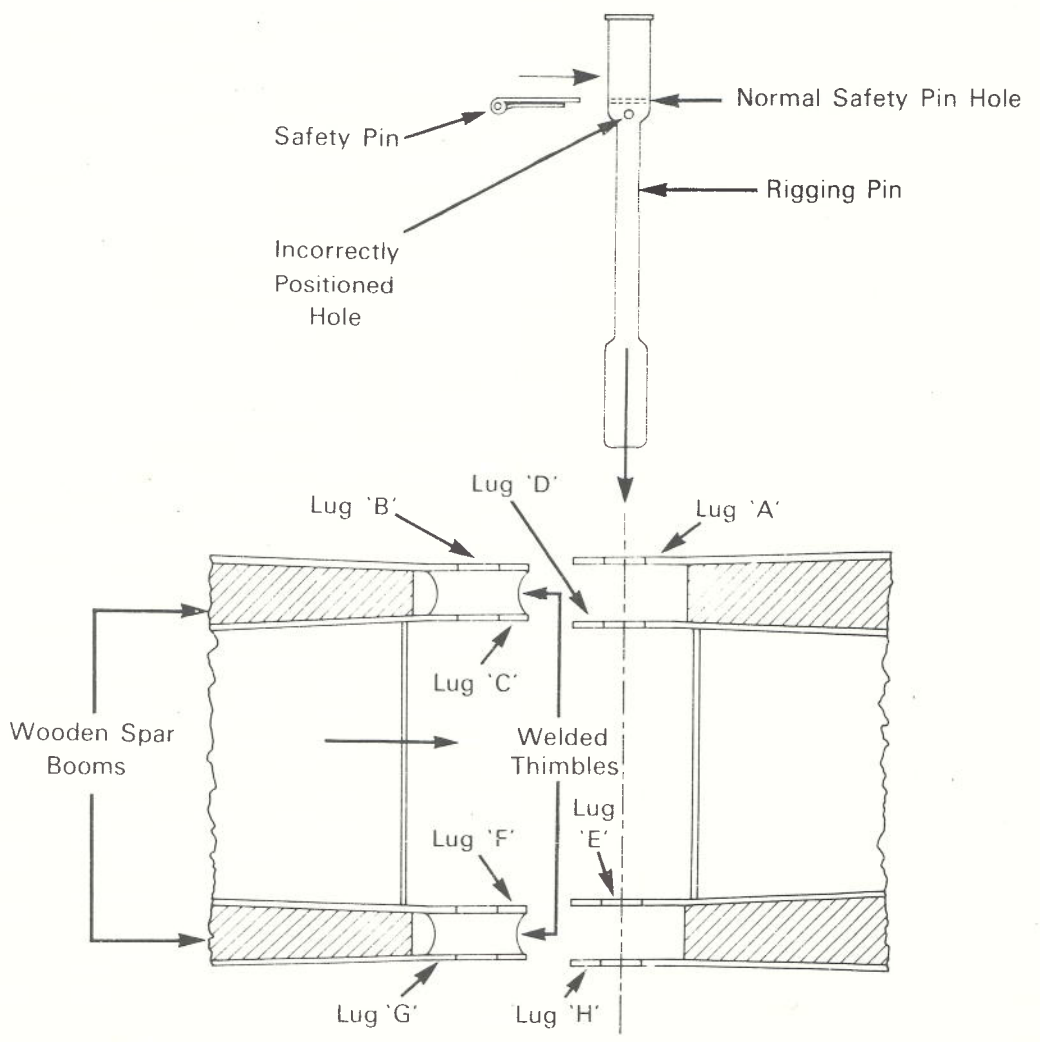
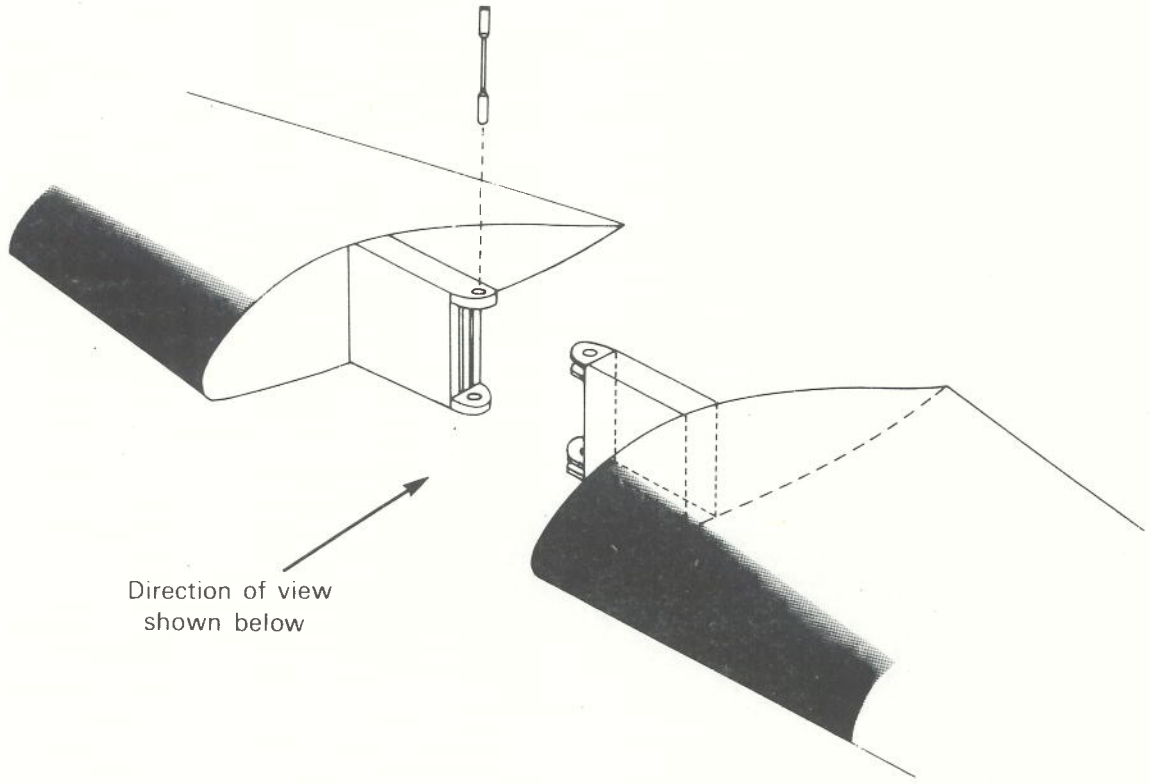
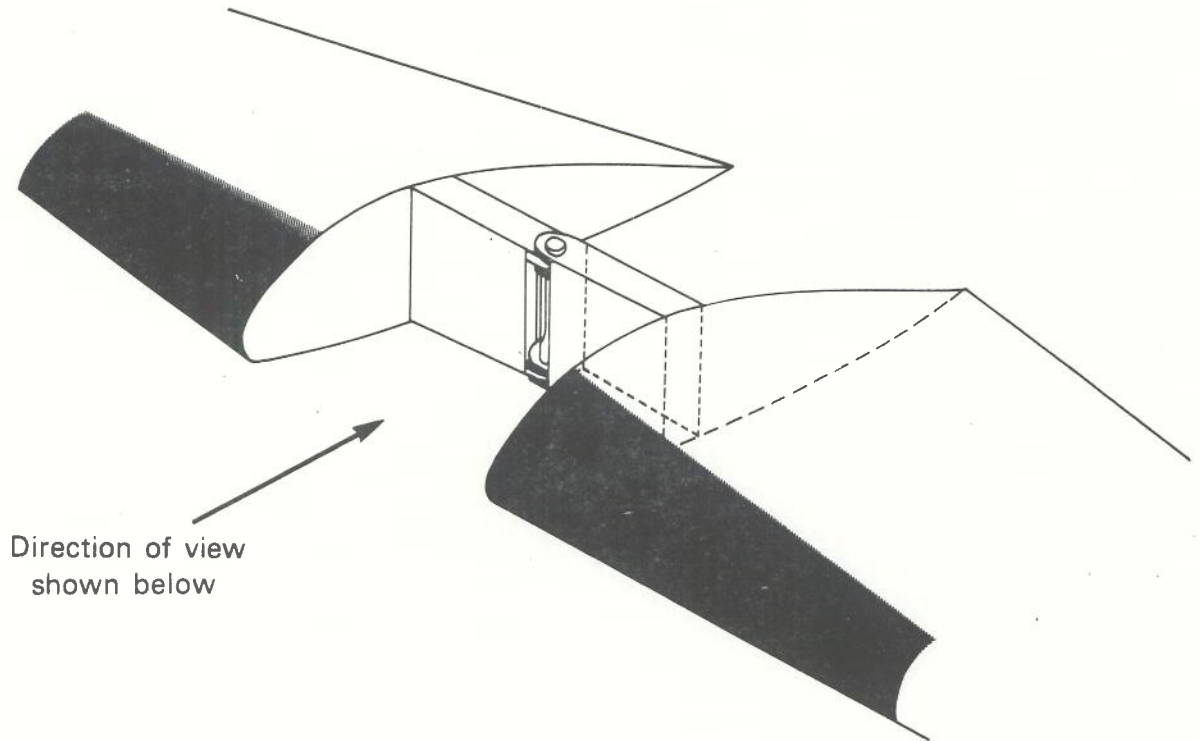

Fig 2

### CORRECT ASSEMBLY OF CENTRE - LINE JOINT



Direction of view  
shown below

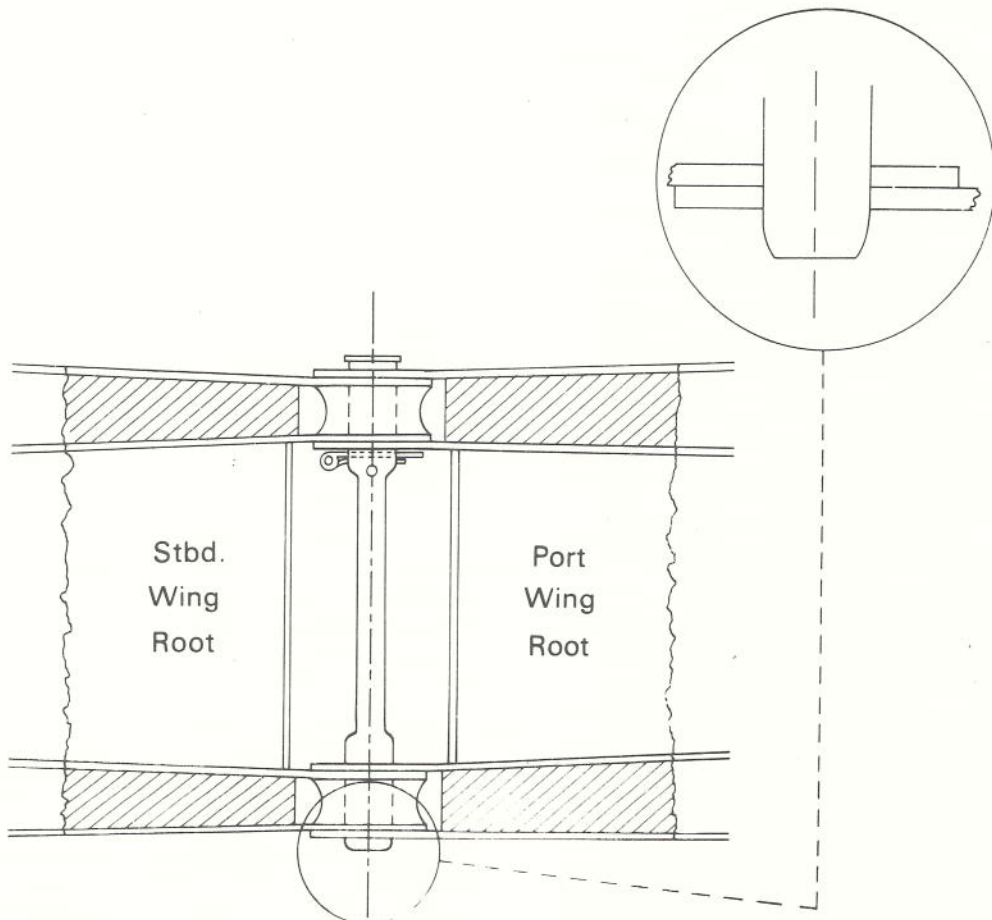

Fig 3

### EFFECT OF INCORRECT POSITIONING OF SAFETY PIN

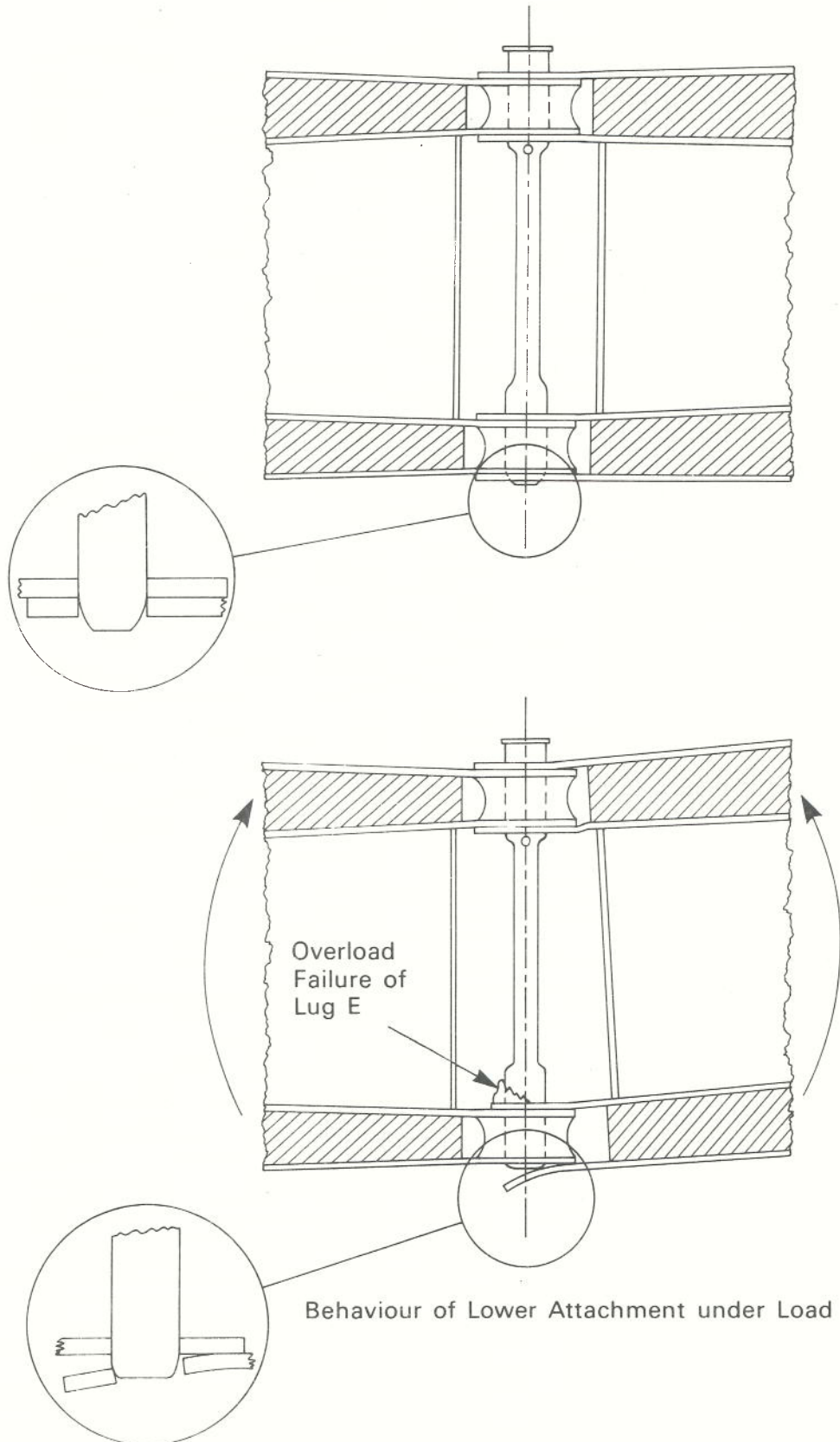
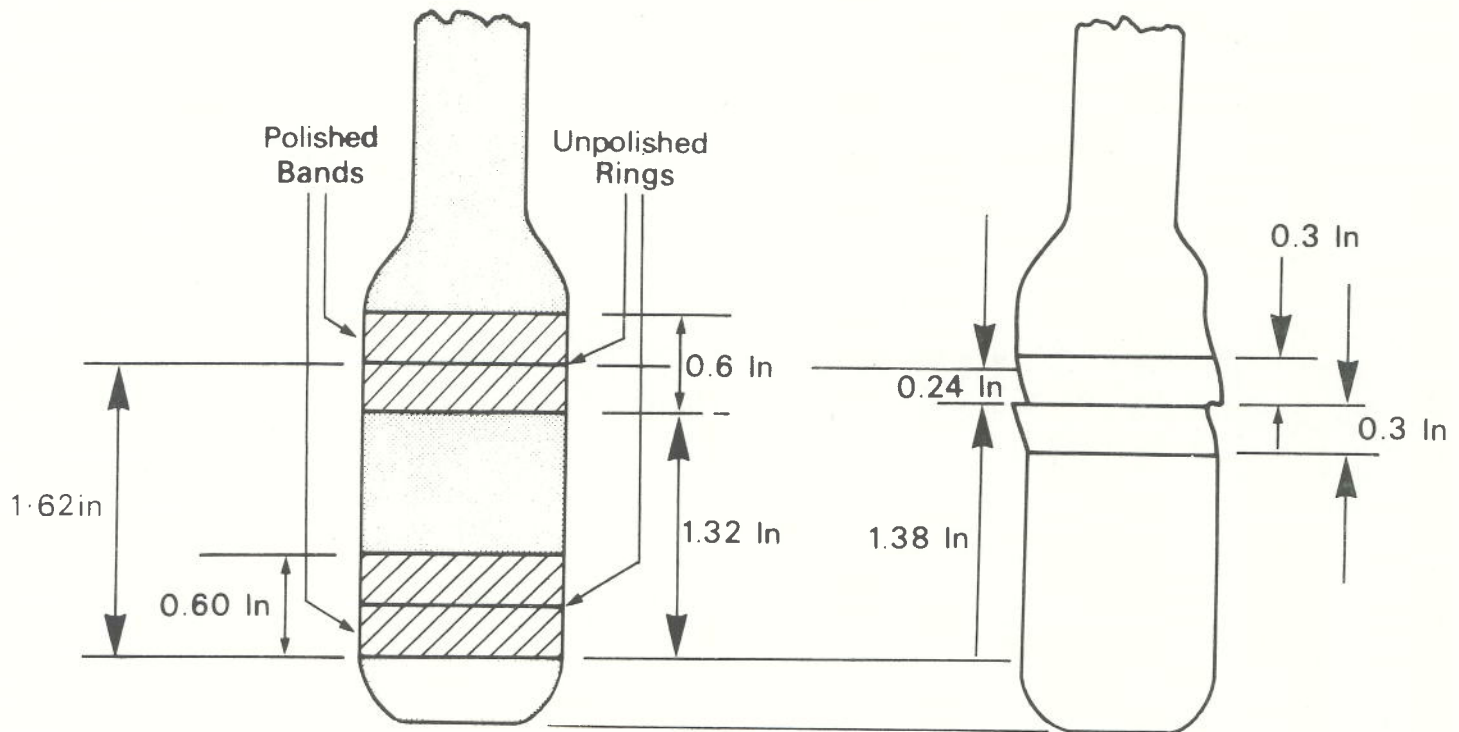

Fig 4

### LOWER END OF RIGGING PIN

Polished Markings on Pin  
(Shear distortion not shown for clarity)

Shear Distortion Marks on Lower  
Section of Rigging Pin



Position of Lugs on lower  
part of Rigging Pin  
in normal flight as  
indicated by polishing  
marks

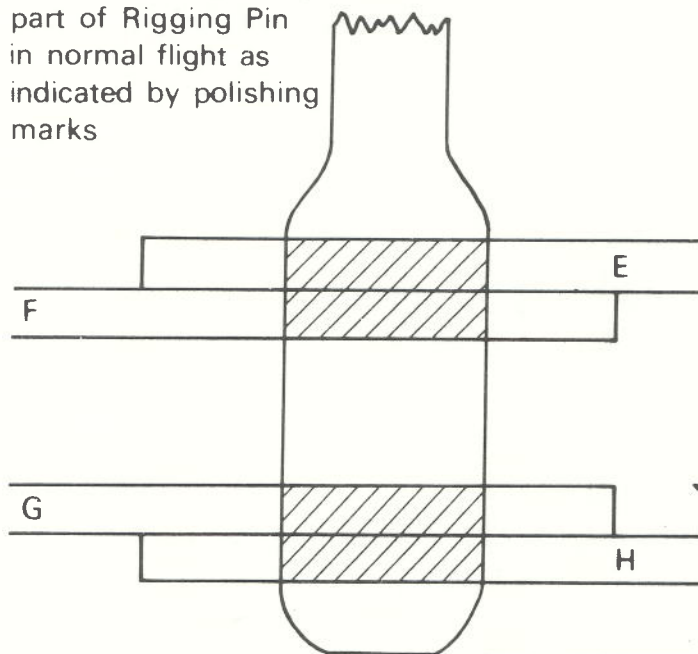

Position of Lugs on lower part  
of Rigging Pin at the  
time of failure as  
indicated by shear  
distortion  
of Pin

