Department for Transport

AAIB Bulletin S9/2006

SPECIAL

INCIDENT

Aircraft Type and Registration:	Airbus A319-111, G-EZAC
No & type of Engines:	2 CFM56-5B5/P turbofan engines
Year of Manufacture:	2006
Date & Time (UTC):	15 September 2006 at 1052 hrs
Location:	Near Nantes, France
Type of Flight:	Commercial Air Transport (Passenger)
Persons on Board:	Crew - 6 Passengers - 138
Injuries:	Crew - None Passengers - None
Nature of Damage:	None
Commander's Licence:	Airline Transport Pilot's Licence
Commander's Age:	42 years
Commander's Flying Experience:	8,782 hours (of which 394 were on type) Last 90 days - 211 hours Last 28 days - 77 hours
Information Source:	AAIB Field Investigation

This bulletin contains facts which have been determined up to the time of issue. This information is published to inform the aviation industry and the public of the general circumstances of accidents and must necessarily be regarded as tentative and subject to alteration or correction if additional evidence becomes available.

Extracts can be published without specific permission providing that the source is duly acknowledged.

Synopsis

The aircraft was dispatched under the provisions of the operator's Minimum Equipment List with the Auxiliary Power Unit (APU) generator on line, substituting for the No 1 main generator which had been selected off after a fault on the previous flight had caused it to trip off line. During the cruise, the APU generator disconnected from the system, probably because of a recurrence of the original fault. This caused the loss of a substantial number of aircraft services, including some flight instruments and all means of radio telephony (RTF) communication. Manual reconfiguration of the electrical system should have recovered many of the services but the flight crew was not able to achieve this. Since they were without RTF communications, the crew considered that the best option was to select the emergency transponder code and continue the flight in accordance with the flight plan.

In the light of the initial findings of the investigation, four safety recommendations are made. The investigation is continuing.

History of the flight

On the previous sector, en-route from London Stansted to Alicante, Spain, the No 1 Integrated Drive Generator (IDG1) failed; the crew attempted a reset but it was unsuccessful. The aircraft was subsequently despatched from Alicante for a flight to Bristol with IDG1 selected OFF under the provisions of the operator's Minimum Equipment List (MEL). The APU generator was operating and supplying the AC1 busbar, with IDG2 supplying the AC2 busbar as normal (see 'Electrical system description' below).

The pilots reported that, while the aircraft was in the cruise at Flight Level (FL)320, under the control of Brest

ATCC, they heard a 'CLUNK' and a number of services were lost, as follows:

- Captain's Primary Flight Display, Navigation Display, upper Electronic Centralised Aircraft Monitoring (ECAM) display and Multi-purpose Control and Display Unit (MCDU);
- Autopilot; the associated aural Master Warning tone sounded;
- Autothrust; the associated aural Master Caution tone sounded;
- All caption and integral illumination lights on the overhead panel;
- A number of displays and lighting on the centre pedestal.

The commander, who was the Pilot Flying, had no flight instrument displays except the standby instruments. He checked that the co-pilot's instruments were still available and handed him control. The co-pilot noted that the aircraft's flight control system was now in 'alternate law'. The commander proceeded to carry out the ECAM actions, which were displayed on the lower ECAM screen. The first action was to select the AC ESS FEED push button to alternate (ALTN), but this had no effect. He commented that the push button caption was not lit and he was unable to see whether the push button was selected to normal or alternate. Concerned that he was not able to re-establish electrical power, he attempted to transmit a MAYDAY to Brest ATC. He tried both VHF1 and VHF2 on his own Radio Management Panel (RMP), asked the co-pilot to try from his RMP and later also attempted to select VHF3 using the observer's communication equipment. All attempts to re-establish RTF communications were unsuccessful.

Continuing with the ECAM actions the commander selected ATC2, the alternative transponder. The digit display, which had been blank, returned and he selected the emergency 7700 code to alert ATC to the fact that the aircraft had a problem. After considering the options for the flight he decided that the best course of action was to continue to the original destination in accordance with the flight plan. When the landing gear was selected DOWN during the approach, it failed to extend and the crew used the emergency extension system. The aircraft landed safely at Bristol at 1133 hrs.

Electrical system description

Two engine-driven IDGs normally power the aircraft's electrical services (Figure 1.1). Each IDG provides 3-phase Alternating Current (AC) power to an AC main busbar (AC1 or AC2) via a Generator Line Contactor (GLC). The IDG outputs are isolated from each other by two Bus Transfer Contactors (BTC). A Generator Control Unit (GCU) monitors the IDG output and opens the GLC if it detects an out-of-limits condition. The BTCs then close, to supply both AC main busbars from one generator. Selecting an IDG off also opens the respective GLC. In the event of loss of output from an IDG, a generator driven by the APU can also supply either of the AC main busbars, via the respective BTC. Monitoring and control of the APU generator output is by a combined Ground Power/APU Generator Control Unit (GAPCU). An electrical system control panel is provided in the flight deck overhead panel and system status can be monitored on the lower ECAM display; system operation is normally automatic.

The aircraft manufacturer's Master MEL (MMEL) permits dispatch of the aircraft for non-Extended Twin Operations (ETOPS) with one IDG selected off, provided the APU generator is on line. In this configuration, a fault monitoring facility within the GCU for the inoperative

IDG checks for correct opening of the associated GLC by monitoring the generator current in each phase, as detected by Current Transformers (CT) fitted in the generator. If a fault current is detected, the GCU opens the associated BTC. As this function is intended to protect against failure of the GLC contacts to open, it remains in effect even when the associated IDG is selected off.

The distribution system includes an AC Essential busbar (AC ESS), normally powered from AC1; two DC busbars (DC1 and DC2), normally powered from AC1 and AC2 respectively via Transformer Rectifiers (TR), and a DC Essential busbar (DC ESS), normally powered from DC1 via a DC battery busbar (DC BAT). Each essential busbar supplies an associated Essential Shed busbar. Thus, loss of AC1 results in loss of the AC ESS busbar, and hence the loss of the AC Essential Shed, DC ESS and DC Essential Shed busbars (Figure 1.2). DC1 busbar is also lost; after 5 seconds it is automatically transferred to feed from DC2 via DC BAT, but it does not then supply the DC ESS busbar.

Loss of the AC ESS busbar causes an amber FAULT caption to illuminate in the AC ESS FEED push button. The push button operates a changeover contactor to transfer supply of the AC ESS busbar to AC2. This action restores the AC ESS busbar, the AC Essential Shed busbar and, via the Essential TR, the DC ESS busbar and DC Essential Shed busbar, and illuminates a white ALTN caption in the push button.

Loss of the AC1 busbar, prior to transfer of the AC ESS busbar to AC2, will result in loss of all the annunciator lights powered by these two busbars. However, annunciator lights powered by the AC2 or battery busbars should still be operative.

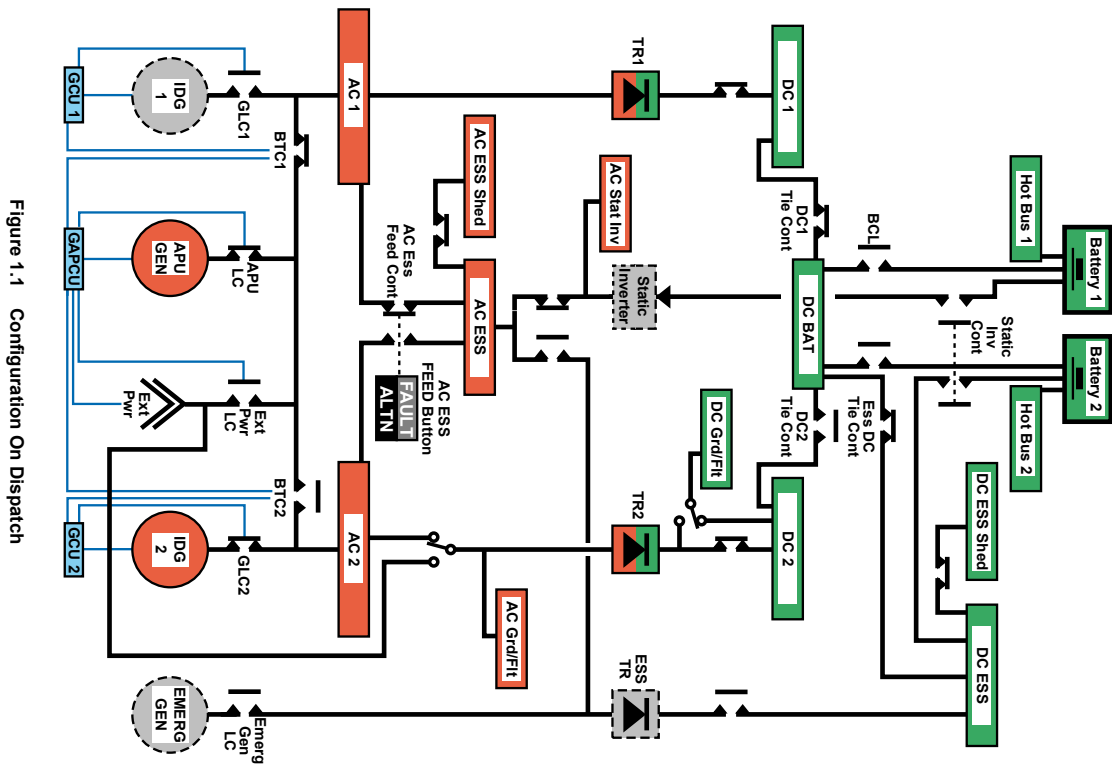

Figure 1.1 Configuration On Dispatch

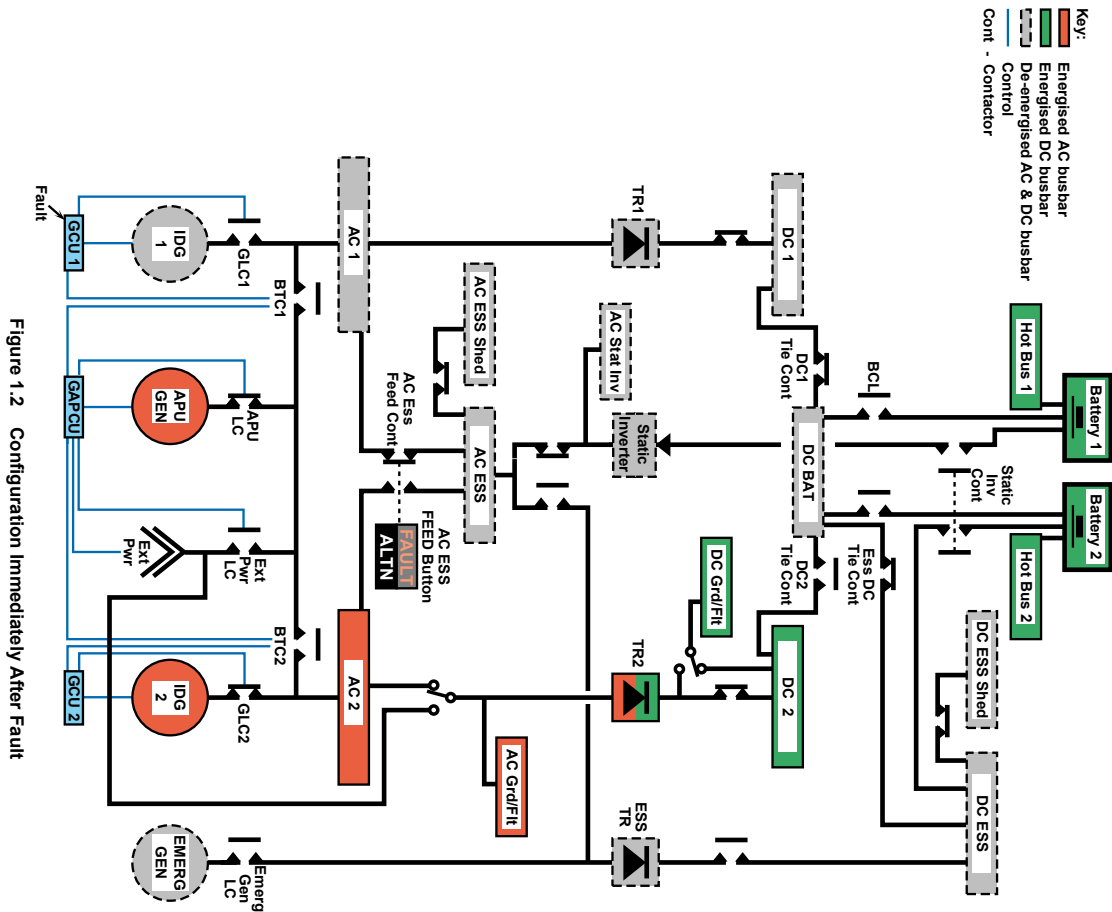

Figure 1.2 Configuration Immediately After Fault

Figures 1.1 and 1.2
Electrical Distribution System Schematic

G-EZAC was fitted with an upgraded digital Audio Management Unit (AMU) for all the RTF communications. Unlike earlier versions, its operation depended on a power supply from a single busbar (DC ESS). Airbus advised that this meets present certification standards.

Flight recorders

Data was recovered from both the CVR and FDR. The FDR was powered by the AC2 busbar and remained recording throughout the flight. The data confirmed that at the start of the incident the aircraft was flying at FL320 at an indicated airspeed of 277 kt. At 10:52:40 hrs the AC1, AC ESS and DC ESS busbars de-energised, and did not recover until after landing. The system losses reported by the crew were all consistent with the loss of these busbars. The data showed that BTC2, which was initially open, cycled three times shortly after the loss of the busbars, consistent with the APU generator or IDG2 switching off and on line.

The CVR was powered from the AC Essential Shed busbar and recording ceased at the time of the incident.

Aircraft inspection and testing

Following the incident, inspection and wiring checks of possibly relevant parts of the aircraft electrical system revealed no signs of anomaly. The system functioned normally during engine and APU ground running checks and the indications and functioning of the AC ESS FEED button when AC1 busbar was de-energised were normal. The aircraft system initially failed to accept external electrical power, but eventually did so. Bench testing of the AC ESS FEED button and associated contactors and relays found no signs of anomaly.

However, laboratory testing did reveal an intermittent fault with GCU1, whereby a current was incorrectly

detected by one of the CTs within the generator. This corresponded with data recorded for trouble-shooting purposes by the aircraft fault monitoring system when IDG1 had tripped off line on the previous flight. The post-flight report provided by the system included a fault code 'IDG1(E1-4000XU)GEN CT/GCU1(1XU1)'. The data indicated that a similar fault had caused the de-energisation of the AC1 busbar during the flight to Bristol. Initial evidence indicated that the GCU1 monitoring system had incorrectly interpreted the fault in the GCU itself as a fault in the open GLC1. The GCU had consequently locked open BTC1, thus disconnecting the APU generator from the AC1 busbar. The testing also revealed a fault in the GAPCU.

Investigations are continuing into the causes of the GCU1 and GAPCU faults, the possible reasons for the reported anomalies with the AC ESS FEED button captions and function, and the causes of the external power acceptance difficulties.

Other information

During the investigation it became apparent that a manufacturing problem had resulted in a hardware fault within a number of GCUs and GAPCUs of the type fitted to G-EZAC (used on A320 series, A330 and A340 aircraft). It had been found that the contents of a Static Read-Only-Memory (SRAM) component could alter and that this would result in a GCU 'Failsafe' fault and isolation of the associated IDG from the electrical system. The system could usually be reset by cycling the associated generator ON/OFF push button. The aircraft manufacture had issued an Operator's Information Telex (OIT 999.0106/06, issued 24 August 2006) listing the serial numbers of the approximately 2,200 units affected and recommending that each aircraft should have at least two units that had not experienced a failsafe issue in the last 30 days.

The OIT was issued for maintenance purposes rather than flight safety reasons and, therefore, was not made available to flight crews.

Discussion, safety action and recommendations

The evidence indicated that a monitoring system had incorrectly interpreted a fault in GCU1 as a GLC1 fault and opened BTC1 as a result. This had disconnected the APU generator from the AC1 busbar, leading to the loss of AC1 and a number of other busbars, including the AC ESS and DC ESS busbars. It was undesirable that the incorrect interpretation of a single fault should cause the loss of a main busbar. At this time the inappropriate action by the GCU appears to have been due to inadequate logic in the monitoring system. Therefore:

Safety Recommendation 2006-142

It is recommended that Airbus should revise, for the A320 aircraft series, the fault monitoring logic of the Generator Control Unit to prevent the monitoring system from incorrectly interpreting a fault within the GCU as an external system fault.

In response to this issue, Airbus has confirmed that the GCU fault monitoring system will be improved. Actions are being taken by Airbus and by the GCU supplier for a software modification, which will be included in the next GCU standard to be released. At present, however, it is not known when this will be issued.

It was a matter of particular concern that repetition of the same fault that had led to G-EZAC's dispatch with the IDG inoperative could subsequently cause isolation of the APU generator that was substituting for the IDG. Airbus has stated that their System Safety Assessment predicts a sufficiently low probability of recurrence of this situation to allow their safety objectives to be met

in this dispatch configuration. Therefore the AAIB does not intend to make a safety recommendation regarding this MMEL provision, at this time.

Implications of the potential GCU and GAPCU faults due to a SRAM defect, while not apparently relevant to this incident, also raised concerns about the adequacy of the procedures for dispatching with one IDG inoperative. It was recommended in the OIT that each aircraft should have at least two units that had not experienced a failsafe issue in the last 30 days. This suggested that a lower standard of airworthiness might result if an aircraft was dispatched with one IDG inoperative and with the remaining IDG or APU generator controlled by a unit from the affected batch, and hence of degraded reliability. However, the Operational Procedure associated with such a dispatch by the flight crew, did not require a check of whether the active GCU and GAPCU were from the batch affected by the SRAM defect. Airbus have taken action to retrofit all affected GCUs and advise that it is hoped this can be achieved by the end of 2006. They are also considering issuing a revised OIT to recommend that flight crews should obtain advice from their maintenance organisation before dispatching with IDG1 inoperative. Therefore the AAIB does not intend to make a safety recommendation on this matter at this time.

The aircraft's electrical distribution system is automatic in both normal operation and in some failure situations. It was apparent that the AC1 busbar is a crucial part of the system and its de-energisation results in a major loss of aircraft services, possibly at a critical stage of flight. Because the transfer of the AC ESS busbar did not occur, this resulted in a continued loss of essential services for the remainder of the flight.

It was intended that operation of the AC ESS FEED push button would restore many of the services; Airbus reported that the average observed time for a crew to operate the push button switch in these circumstances is around one minute. It was considered preferable that this should be accomplished automatically. Therefore:

Safety Recommendation 2006-143

It is recommended that Airbus should introduce, for Airbus A320 series aircraft, a modification to automatically transfer the electrical feed to the AC Essential busbar in the event of the loss of the No 1 Main AC busbar.

Airbus have been studying the feasibility of a modification to provide, in such circumstances, automatic transfer of the AC ESS busbar to AC2. The status of this possible modification will be provided at the beginning of January 2007.

The loss of all RTF communication capability was of major concern. It had resulted because the AMU, and thereby the entire RTF communication system, relied on a power supply from the DC ESS busbar. While it was to be expected that in this case the busbar would be restored by transferring the AC ESS busbar to feed from AC2 busbar, other failures could cause the permanent loss of the DC ESS busbar.

Airbus stated that the certification criteria for A320 series aircraft, i.e. a probability of a total loss of RTF communications of 1×10^{-5} per flying hour, is met. The AAIB considers that the reliance of all the

RTF communication system on a single busbar is undesirable and is unlikely to be generally known by operators or crews of affected A320 series aircraft. Furthermore, the Flight Crew Operations Manual (FCOM) and existing ECAM procedures do not reflect this configuration. The following two safety recommendations are therefore made:

Safety Recommendation 2006-144

It is recommended that Airbus should advise all operators of A320 series aircraft with Radio Telephony (RTF) communications reliant upon a single busbar of the consequent possibility of loss of all RTF communications.

Safety Recommendation 2006-145

It is recommended that, for A320 series aircraft with digital Audio Management Units, Airbus should take modification action aimed at ensuring that electrical power supplies required for Radio Telephony communications have an improved level of segregation.

Airbus has advised that it intends to inform the airlines concerned. Additionally, even though the current certification standard is met, Airbus is studying the feasibility of modifying the power supply to the digital AMU for A320 series aircraft.

The AAIB is continuing to investigate this incident with the cooperation of the manufacturer and the operator, and will publish a further report when the investigation is complete.