

<b>Aircraft Type and Registration:</b>	Boeing 737-59D, G-BVKC	
<b>No &amp; Type of Engines:</b>	2 CFM56-3C1 turbofan engines	
<b>Year of Manufacture:</b>	1990	
<b>Date &amp; Time (UTC):</b>	21 February 2004 at 2300 hrs	
<b>Location:</b>	Cardiff Airport, Wales	
<b>Type of Flight:</b>	Public Transport (Passenger)	
<b>Persons on Board:</b>	Crew - 6	Passengers - 114
<b>Injuries:</b>	Crew - None	Passengers - N/A
<b>Nature of Damage:</b>	Damage to left main landing gear	
<b>Commander's Licence:</b>	Airline Transport Pilot's Licence	
<b>Commander's Age:</b>	49 years	
<b>Commander's Flying Experience:</b>	8,160 hours (of which 3,800 were on type) Last 90 days - 203 hours Last 28 days - 71 hours	
<b>Information Source:</b>	AAIB Field Investigation	

### **Synopsis**

The left main landing gear (MLG) began a violent shimmy (yaw oscillation) when the wheelbrakes were applied after a normal landing touchdown, probably damaging the MLG lower torsion link. The shimmying stopped when braking was reduced but restarted when braking was increased, causing the torsion link to fracture. Further higher amplitude shimmying of the left MLG ensued, resulting in severe MLG tyre, wheel and brake damage and substantial oscillatory loads on the aircraft structure. Steering difficulties were experienced during both shimmying episodes.

It was likely that the shimmying resulted from excessive wear of the torsion link apex joint that reduced the effectiveness of the shimmy damper. Maintenance records indicated that the MLG had been maintained in accordance with the manufacturer's recommendations, but it was considered that relevant Aircraft Maintenance Manual (AMM) procedures could be difficult to follow.

Similar failures had occurred over a number of years, which had been attributed by the aircraft manufacturer to excessive apex joint wear that had not been detected or adequately rectified during maintenance. One safety recommendation has been made.

### **History of flight**

The aircraft had flown from Malaga to Cardiff with the commander as the handling pilot. After an uneventful cruise, the crew checked the weather at Cardiff Airport and were told that Runway 12 was in use with a surface wind of 040°/20 kt gusting 31 kt. As a wind from this direction is known to cause turbulence over the threshold of Runway 12 the crew requested, and were granted, an approach to the reciprocal, Runway 30. An ILS approach was made with anti-skid selected on, autobrake off and a final flap setting of 30°.

Although the approach was moderately turbulent, the commander was able to maintain a constant angle of drift throughout the latter stages where the wind readouts remained constant at 040°/20 kt with no gusts. The drift was reduced using rudder as the aircraft flared and touchdown was made after a short float.

Touchdown was described by the crew as firm, but not heavy, and without excessive sideways drift. Reverse thrust was selected and the handling pilot commenced manual braking without delay. Almost immediately, the crew experienced very heavy vibration and felt the aircraft pulling to the left. Braking application was reduced and the vibration lessened. Firm braking was again applied at an estimated 60 kt and extremely heavy vibration again occurred. Both pilots felt a significant lateral acceleration to the left. In the cabin, the vibration was severe enough to cause one of the overhead lockers to unlock and spill its contents. This time, the commander used the tiller in an attempt to regain the runway centreline and he brought the aircraft to a halt on the runway.

The Airport Fire Service (AFS) arrived at the aircraft and reported that there was no fire but that there appeared to be brake unit parts on the runway. Passengers were disembarked from the aircraft without incident whilst it remained on the runway and shutdown checks were completed by the crew before they vacated the aircraft.

On the day previous to this incident, another company pilot reported that, following a normal landing, an unusual juddering was felt through the rudder pedals when heavy braking was demanded. As the braking was eased, the vibration stopped and the aircraft was taxied onto stand without further incident. This judder was not felt by the non-handling pilot.

## **Aircraft description**

The Boeing 737 main landing gear (MLG) leg consists of a cylinder/piston type shock-strut, with the cylinder attached to the wing structure and the lower end of the piston carrying an axle with two main wheels. The axle centreline is located 3.5 inches behind the shock-strut centreline to provide a castoring effect. MLG wheels and tyres are numbered 1 to 4, left to right, across the aircraft. A scissor linkage, made up of two torsion links, is intended to prevent rotation of the piston relative to the cylinder, while allowing axial movement of the piston within the cylinder to provide shock absorption, Figure 1. The upper torsion link is attached to the cylinder via a horizontal pivot joint and the lower torsion link is similarly pivoted onto the piston.

A damper is connected between the apexes of the upper and lower torsion links in order to control the rotary oscillation of the shock-strut piston relative to the cylinder and thereby prevent excessive MLG vibration during high-speed taxi and under heavy braking. The damping action is effected by a piston fitted in a fluid-filled cylinder in the damper body; a damping orifice in the piston controls the rate of displacement. The apex of the upper torsion link is bolted to the damper body and the apex of the lower link is connected to the damper piston rod via a bearing assembly. This consists of spherical bushes sandwiched between two thrust washers and is clamped against a shoulder on the rod by an end nut. Thus the torsion links can pivot relative to each other but horizontal displacement between their apexes is controlled by the damper action.

A fluid pressure of 30 to 70 psig is maintained within the damper by a compensator, in conjunction with two check valves. A further check valve allows fluid to enter the damper from the return side of the aircraft's Hydraulic System A to make up for leakage from the damper or to compensate for volume changes associated with temperature variation. Protection from excessive pressure resulting from thermal effects is provided by two relief valves. Air entering the damper during maintenance operations can be released via three bleed plugs.

## **Accident site**

Runway 30 is 2,392 metres long and 46 metres wide, with a Landing Distance Available of 2,201 metres. The surface is generally concrete but tarmac in places. The aircraft had been removed by the time of AAIB arrival but runway tyre track markings, clearly associated with G-BVKC's landing roll, were apparent on the runway. These were continuous from touchdown to the point at which the AFS reported that G-BVKC had come to rest, Figure 2. Runway access was limited by heavy traffic and the measured distances were approximate.

The tracks started as two pairs of dense black MLG tyre tracks commencing approximately 754 metres from the Runway 30 threshold, towards the end of the normal touchdown area, as

indicated by other tyre markings. The tracks showed that Tyre 4 had touched first, with the aircraft 2 metres left of the runway centreline, followed after 3.5 metres by Tyre 3 and after a further 6 metres by Tyres 2 & 1, indicating touchdown with some right bank. The markings showed that the aircraft initially ran straight for about 86 metres, while gradually regaining the centreline.

The left MLG tyre tracks then began a sinusoidal oscillation, with a wavelength of 4.8 metres and a half-amplitude of 5 to 10 cm, that continued for 183 metres. After this the left MLG tracks became straight for 609 metres, with the aircraft diverging somewhat left of the centreline, before curving sharply to the right and commencing a second period of oscillation. The subsequent tracks were generally sinusoidal, with a wavelength of 2.3 metres and a half-amplitude of 15-20 cm, but part way through each swing to the left the wave was distorted and a dense black scrub mark was apparent. This was consistent with restraint of the yaw oscillation by contact of the No 2 wheel/tyre/brake assembly with the torque link/shimmy damper assembly as the axle approached its peak left yaw angle. The detached brake unit parts were found in the region of these second oscillation markings.

The apparently vigorous oscillation continued for 88 metres, to close to the point at which G-BVVC had come to rest, approximately 439 metres from the end of the runway. The total ground roll distance was around 1,008 metres.

### **Aircraft examination**

In view of the substantial oscillatory loads on the aircraft reported by the crew, the MLG attachment structure was inspected; no damage was found. The outboard side of the left MLG No 2 wheel, tyre and brake had sustained significant damage, which could be matched with impact damage to the damper body and parts of the lower portion of the shock-strut cylinder. The parts found on the runway had originated from these components. Some localised damage had been caused to the No 1 wheelbrake. These effects had clearly been caused by large yaw excursions of the axle and wheel assembly.

The left MLG lower torsion link (Part Number 65-46102-21) had broken mid-way along its length, at a point where a cut-out in the flange of the link formed two 'T' section limbs, both of which had fractured. Specialist examination concluded that the fractures had resulted from overload, approximately in the plane of the link, with the left limb having failed first and the right limb fracture showing signs of very low cycle, very high stress load reversals. One of the five bolts attaching the upper torsion link to the damper body had fractured and the damper piston rod had bent. The inner part of the rod had been gouged and the apex joint spherical bushings had suffered local compression collapse, with bronze material from the bushings smeared onto the mating surface of the thrust washers. These features were consistent with the damage to both the torsion link and the damper having resulted from excessive loads associated with MLG shimmying.

It was also found that material had been lost from the mating faces of the inner thrust washer and the piston rod shoulder, apparently due to in-service wear, rather than the effects of shimmying. No hydraulic fluid leakage from the shimmy damper was evident and aircraft checks found that the hydraulic supply to the left MLG shimmy damper was normal.

### **Flight recorders**

The Cockpit Voice Recorder (CVR) had not been isolated after the accident and the recording of the landing had been overwritten.

A satisfactory readout of the Flight Data Recorder (FDR) was obtained. Hydraulic system pressures and brake pressures were not recorded. The data indicated that the landing touchdown had not been heavy or made with excessive drift. Longitudinal deceleration of the aircraft increased to a level consistent with firm braking within approximately two seconds of touchdown. Two periods of elevated, oscillating lateral acceleration were experienced during the ground roll, the first between 140 and 120 kt groundspeed and the second between 35 and 0 kt.

### **Maintenance requirements**

The applicable issue of the Aircraft Maintenance Manual specifies a number of checks and maintenance operations related to the MLG torsion links and the shimmy damper, as follows:

1. MLG Torsion Link Apex Joint Inspection (Task 32-11-00-206-053):

The procedure notes:

*'The apex joint inspection is important to make sure the shimmy damper functions properly and the apex thrust washers or apex bushings are not worn such that the shimmy damper effectiveness is reduced.'*

A check of the clearance between the outer thrust washer and the apex nut is required (not illustrated). If this is less than 0.005 inch it is required that the tightening torque of the apex nut is checked (see Paragraph 2, below) and the minimum axial dimension of the apex bearing assembly (between the outer faces of the thrust washers) is measured. If this dimension is less than 2.700 inches, replacement of the apex bushings and/or thrust washers is required. If the thrust washer/apex nut clearance is greater than 0.005 inch, it is required that the apex joint is disassembled and:

*'if necessary replace worn, fractured or cracked apex bushings or apex thrust washers'.*

After re-assembly of the joint a check of the minimum axial dimension of the apex bearing assembly is required. If this is greater than 2.700 inches the inspection is complete.

2. MLG Damper - Adjustment/Test (Task 32-11-81-705-001):

The procedure requires the damper piston to be positioned such that the end of the piston rod opposite the apex joint protrudes between 0.10 and 0.15 inches from the damper body, before the torsion link apex joint nut is tightened. If necessary, the dimension is to be achieved by jacking the MLG off the ground and levering the wheels with a length of wood to turn the lower torsion link. The apex nut is then tightened to 400 and 500 lb.inch, before being completely slackened and re-tightened to 50 and 150 lb.inch and locked. This is followed by a check of the gap between the outer thrust washer and the nut of the apex joint. If this is not more than 0.005 inches, no further adjustment is needed. If it is more than 0.005 inches it is required to:

*'do a check on the apex thrust washers and the lower torsion link bushings for wear.'*

The apex joint inspection specified elsewhere in the AMM (see Paragraph 1 above) is not mentioned.

3. MLG Torsional Free Play Inspection (Task 32-11-00-206-001):

The procedure notes:

*'The torsional free play of each main landing gear must be in tolerance to make sure the main landing gear shimmy is dampened. NOTE: It is important that you adjust the shimmy damper correctly and tighten the apex nut of the torsion link to specified torque [see Paragraph 2 above] before you do a check on the torsional play of the main landing gear (AMM 32-11-81/501).'*

The aircraft is jacked so that the MLG wheels are clear of the ground, the MLG shock-strut is depressurised and the damper is clamped to prevent the piston from moving. A torque is applied to the lower end of the MLG by pulling on a spring balance fitted to a 10 feet long 2 x 4 inch wooden beam placed between the shock-strut and the outboard wheel. The specified torque is that produced by applying a 30 lb pull to the beam at a point 100 inches from the shock-strut centreline. The fore and aft motion of the inboard wheel rim produced by applying the torque clockwise and then anti-clockwise is measured using a dial gauge located at a point on the forward side of the wheel in the horizontal plane through the axle centreline. The play obtained from averaging five measurements is required to be less than 0.14 inches. If the play exceeds the limit then inspection in five specified areas, and possibly component replacement, is required; the torsion link apex joint is not specifically included.

#### 4. MLG Torsion Links – Inspection/Check (Chapter 32-11-51/601):

The section specifies wear limits for the torsion link pivot components, including the minimum overall axial dimension of the apex joint bushing/thrust washer assembly. The thrust washer/nut maximum gap is not included. The procedure for installing the torsion links references the AMM procedures given in Paragraph 1 and 2 above, but does not directly specify a check of either apex joint dimensional limit.

#### 5. MLG Torsion Links – Removal/Installation (Chapter 32-11-51/401):

The section specifies the procedure for installing the torsion links. No dimensional checks of the apex bearing after installation are specified.

### **Aircraft background**

Maintenance records indicated that the torsional free play check had last been carried out on G-BVKC's left MLG at a 2C Maintenance Check on 10 April 2003, 2,433 flight hours and 2,144 flight cycles before the accident. The free play was not recorded and there was no requirement to do so. The MLG had last been overhauled 19,413 flight hours and 18,329 flight cycles before the accident. At the time of the accident the aircraft had accumulated 31,210 flight hours and 33,633 flight cycles since new.

The report of a shudder through the brake pedals on a landing the day before the accident was not noticed by the non-handling pilot and appeared likely to have been due to operation of the anti-skid system.

### **Previous history**

Several Boeing publications regarding MLG torsion link fractures on the 737 had been issued prior to the accident, applicable to the -100, -200, -300, -400 and -500 models, as follows:

1. Boeing Message to Operators M-7272-93-6740 and M-7272-93-6816, published 20 Dec 1993:

The message included a report that one operator had experienced fracture of both MLG lower torsion links and fracture of the shimmy damper piston.

2. Boeing 737 Service Letter 737-SL-32-057, published 5 July 1994:

The purpose of the Service Letter (SL) was:

*'To advise operators of recommended maintenance to prevent main landing gear torsion link and shimmy damper piston fractures.'*

It noted that 13 cases of lower torsion link fracture had been reported since 1989 and that investigation of the latest cases had determined that excessive play was present at the apex joint. This had rendered the shimmy damper ineffective and resulted in torsion link loads that had been in excess of design loads, resulting in fractures. The joint was subject to:

*'wear of the bushing inner diameters and flange faces'*

and regular scheduled maintenance was necessary to ensure that this remained within allowable limits. It was intended to revise relevant sections of the AMM to clarify the instructions for the free play check and adjustment of the torsion link apex joint and shimmy damper, and to add wear limits for the apex joint bearing. It was noted that the maximum nut/thrust washer gap was 0.005 inches and the minimum bearing assembly overall dimension was 2.700 inches. The SL noted that:

*'Some operators have initiated a program where the torsion links are replaced at scheduled intervals, such as each C or 2C-check. Other operators may wish to evaluate this practice to help prevent unscheduled maintenance.'*

It also noted that improper bleeding of the shimmy damper, fitment of the wrong damper model or excessive gas pressure in the shock-strut, could also cause torsion link fracture.

3. Boeing Message to Operators M-7200-00-00924, published 20 April 2000:

This referenced the 1993 message and noted that since then Boeing had received additional reports of lower torsion link and shimmy damper fractures, including an instance in 1999 where both lower torsion links had fractured, along with both shimmy damper pistons. All the cases had occurred during the landing roll and none of the aircraft involved had departed the runway. It was concluded from investigation that the fractures had been the result of excessive apex joint play, apparently due to lack of proper maintenance, rather than damper malfunction. The information in the 1994 SL was reiterated. It noted changes to the Boeing AMM and Maintenance Planning Document (MPD), including:

*'The apex joint must be correctly tightened as noted. The maximum gap in the joint is 0.005 inches. Correct tightening will eliminate any gap.'*



4. Boeing Maintenance Tip (MT) 737 MT 32-008, published 2 February 2001:

The MT noted that:

*'Gaps common to the main landing gear torsion links apex joint have resulted in fractures of the torsion link and shimmy damper piston on airplanes in service. In all instances, heavy main landing gear vibration followed torsion link fractures.'*

The dimensional limits given in the 1994 SL were restated, including:

*'If a gap in excess of 0.005 inches is found . . . the apex nut should be removed and the torsion link bushings and thrust washers inspected for wear or fracture.'*

## **Discussion**

It was clear that the vibration and steering difficulties experienced during the landing ground roll had resulted from MLG shimmy and that this had caused the overload fracture of the left MLG lower torsion link. Information from the aircraft manufacturer indicated that a substantial number of similar failures had occurred, over a period exceeding 10 years. Almost all the cases had been attributed to MLG shimmy, resulting from reduced damper effectiveness caused by excessive play in the torsion link apex joint. The play was considered likely to have been due to excessive wear in the joint, apparently because of inadequate maintenance.

Evidence of wear on G-BVKC's components was found and, in the absence of evidence of problems with the damper unit or its hydraulic supply, it was concluded that this had led to the shimmying. It appeared that the link had probably been damaged by the initial episode of violent shimmying that started shortly after a normal touchdown and which ceased when wheelbraking was reduced. Extremely violent shimmying then began at lower speed, when heavier braking was applied, which almost immediately caused the torsion link to fracture. This then allowed a higher amplitude shimmy to develop, resulting in damage to the wheels, tyres and brakes.

The MLG free play and apex joint checks had apparently been carried out at the recommended intervals. However, it appeared that the relevant AMM procedures, presented in five sections of the manual, were not easy to follow, were not fully consistent in some areas and could possibly be misunderstood. Ensuring that the thrust washer/apex nut gap was not excessive was apparently crucial but the procedures did not illustrate the measurement required or suggest a method of manipulating the heavy robust components to enable a small gap between them to be measured reliably.

Additionally, the procedures did not specify that the bushings and/or thrust washers should necessarily be replaced if the thrust washer/nut gap were found to exceed 0.005 inches, but only required them to be inspected. One of the procedures required replacement of worn, fractured or cracked apex bushings or apex thrust washers '*if necessary*'. The other procedure simply specified an inspection for wear. Neither specified a re-check of the gap after re-assembly and both allowed the interpretation that the washer/nut gap could exceed 0.005 inches if the components had been inspected. While the importance of not exceeding the gap limit was strongly emphasised in the Service Letter, Maintenance Tip and Messages to Operators, this was not fully reflected in the AMM. The gap limit was not included, for example, in the table of torsion link assembly wear limits.

### **Safety Recommendations**

There have apparently been a substantial number of MLG torsion link fracture cases brought about by severe shimmying over a period of years. While none of the previous cases resulted in injury, it is clear that such events are likely to have a significant effect on the aircraft's steering capability, could inhibit use of the wheelbrakes in the event of shimmying and are likely to result in wheel, tyre and brake damage. A runway departure could possibly be the eventual result of such an event. Additionally, it appears that the substantial oscillatory loads associated with MLG shimmy, both before and after torsion link fracture, could potentially cause undetected damage to the aircraft structure.

Changes to relevant sections of the AMM and MPD, together with a number of messages from the manufacturer emphasising the recommended maintenance, have apparently failed to prevent recurrence. It is considered that further measures, including an assessment of the need for improved methods of checking for excessive play in the torsion link apex joint and an increased check frequency, improvement to relevant sections of the AMM and assessment of the need for modification of the joint, need to be implemented. It has therefore been recommended that:

### **Safety Recommendation 2004-103**

The Federal Aviation Authority and the Boeing Commercial Airplane Group should take effective measures aimed at preventing further cases of Boeing 737 main landing gear shimmy and resultant torsion link fracturing brought about by excessive play in the anti-torque links apex joint.

Figure 1

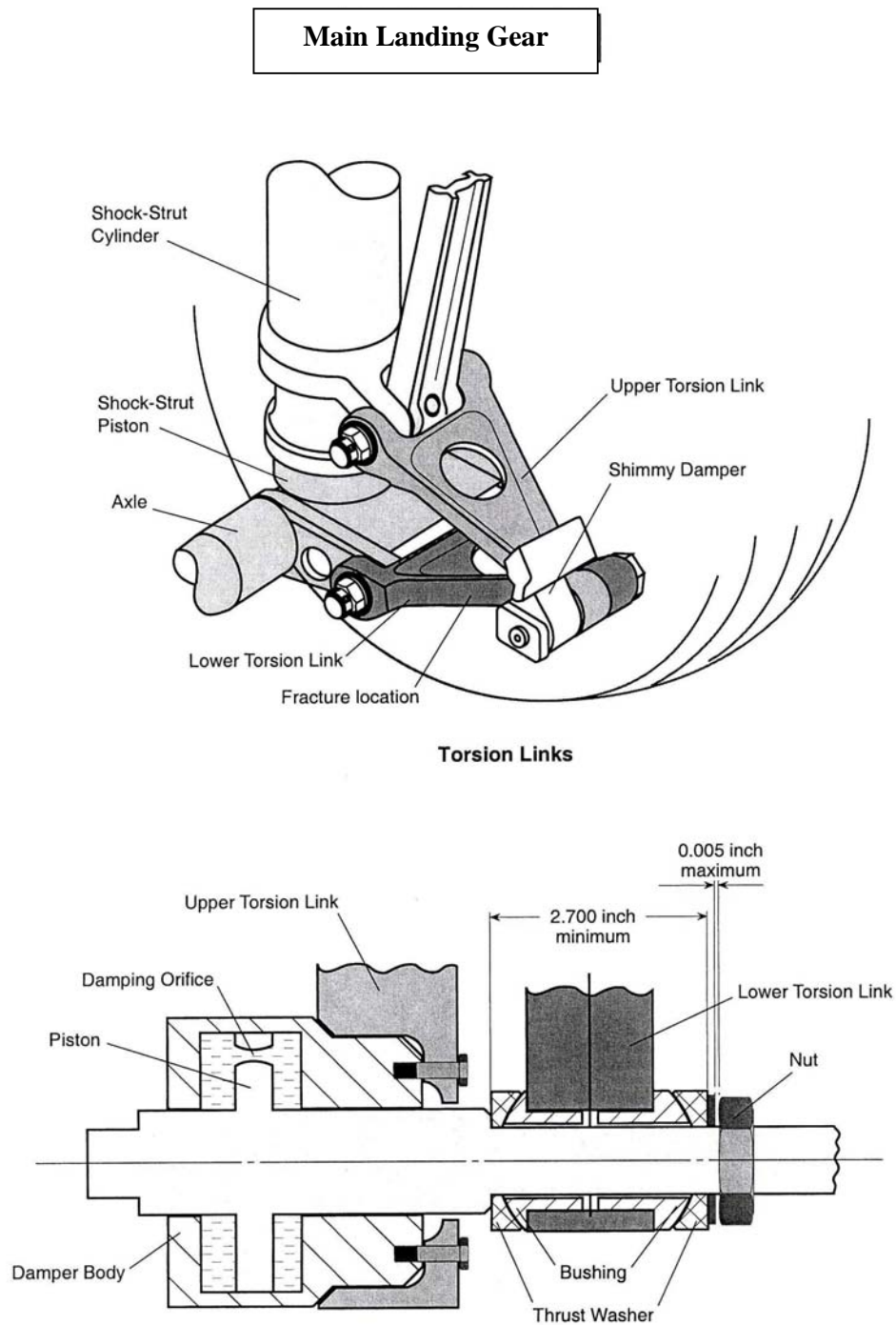

**Shimmy Damper Schematic**

Figure 2

