



Defence
Safety Authority

DSA 03.OME Part 3 Volume 2 - Defence Code of Practice (DCOP) and Guidance Notes for Ranges

Design, Construction and Maintenance of MOD Ranges & Fieldcraft Training Areas (FTA)



Version Record

Version 2.0

Version Date: Jan 2025

Version changes: see amendment table.

Copyright

This document is protected by Crown copyright and the intellectual property rights of this publication belong exclusively to the Ministry of Defence.

Uncontrolled Copies

All hard copies of this document are to be regarded as uncontrolled copies. To check the latest amendment status, reference should be made to current documents which may be viewed on Gov.uk or on the Defence Intranet.

Preface

Requests for Change

1. Proposed changes, recommendations, or amendments to DOSR Regulations and Guidance can be submitted to the DOSR Regulations and Publications Team:

Email Address: dsa-dosr-prg@mod.gov.uk.

Postal Address: Juniper #5004, Level 1, Wing 4, Abbey Wood North, Bristol, BS34 8QW

2. Any post and grammar change proposals can be approved or rejected by the DOSR without involvement of the associated Working Group.

3. Technical change proposals should be submitted to the associated Working Group for review and approval or rejection.

4. When incorporating changes, care is to be taken to maintain coherence across regulations.

5. Changes effecting Risk to Life will be published immediately. Other changes will be incorporated as part of routine reviews.

Review Process

6. The DOSR team will ensure OME Regulations remain fit for purpose by conducting regular reviews through the DOSR Governance Committees, consulting with MOD Stakeholders and other Defence Regulators as necessary on interfaces and where there may be overlaps of responsibility.

Further Advice and Feedback

7. For further information about any aspect of this document, or questions not answered within the subsequent sections, or to provide feedback on the content, contact the DOSR Regulations and Publications Team.

Amendment Record

No	Section	Para	Amendment Summary	Agreed	Date
1	all	all	Document first published.	DOSR TL	May 20
2	all	all	Formatted in line with DSA accessibility requirements.	DOSR/ RITT	Jan 25

Contents

Chapter 1 - Range Grouping

Permanent Training Ranges	1-1
Environmental Issues	1-2
Temporary Exercise Ranges	1-3
Operational Theatre Range	1-3
Sea and Air Danger Areas	1-4
Works Procurement and Refurbishments	1-4
Facilities Management	1-4
Sustainable Development	1-4
Annex A - Procurement of a New Range - Range and Training Staff Guide	1A-1

Chapter 2 - Range Design Criteria and Specifications

Introduction	2-1
Range Safety Terminology	2-1
Principles of Range Design, Maintenance, Operation and Decommissioning	2-11
Ballistic Performances of Weapons and Ammunition on Ranges	2-13
Range Details and Drawings	2-15
Range Types	2-18
Range Design	2-20
Sand Bullet Catchers	2-35
Granulated Rubber Bullet Catchers	2-37
Tarmac For Range Floors and Roads Crossing Range Floors	2-39
Environmental Bullet Catchers	2-40
Impact Areas	2-40
Control of Access	2-42
Fences	2-42
Signs and Notices	2-43
Flagging / Red Lights	2-47
Surveillance and Sentries	2-47
Works Range Structure Inspections	2-47

Chapter 3 - Indoor Ranges

Design	3-1
Construction	3-3
Range Building	3-3
Defence Zone	3-4

Backplate	3-4
Bullet Catcher	3-5
Anti-Splash Curtain (Low Velocity Ranges)	3-6
Targetry	3-7
Floor	3-8
Walls	3-8
Ceiling	3-8
Baffles and Timber Cladding	3-9
Firing Points and Lanes	3-9
Fire Hazard	3-10
Communications	3-10
Maintenance	3-11
Compliance Check	3-11

Chapter 4 - Non-Standard Range (NDA, LDA and FDA)

Design Procedures (New or Modified Ranges)	4-1
Design	4-2
Construction	4-6
Communications	4-8
Maintenance	4-8
Built To Design Range (BTDR)	4-8
Compliance Checks	4-10

Chapter 5 - The Close Quarter Battle Range (Urban)

Danger Areas	5-1
Design	5-1
Range Options	5-3
Construction (Permanent and Semi-Permanent ranges)	5-4
Maintenance	5-8
Communications	5-8
Additional Details for CQB (U) Shoot Through Facilities	5-9

Chapter 6 – The 25m Barrack Range

Design	6-1
Construction	6-2
Target Area	6-2
Range Floor	6-3
Firing Points	6-4
Lighting	6-4

Communications	6-4
Maintenance	6-4
Previous Version.....	6-5
Compliance Checks.....	6-5

Chapter 7 - The 1908 Design Barrack Range

Design	7-1
Construction.....	7-2
Target Area.....	7-2
Range Floor.....	7-3
Firing Points.....	7-4
Lighting	7-4
Communications	7-4
Maintenance	7-4
Compliance Checks.....	7-5

Chapter 8 - Tube Ranges

Design	8-1
Construction.....	8-2
Tube	8-3
Firing Bay.....	8-4
Safety Measures.....	8-6
Communications	8-7
Safety Signs.....	8-7
Maintenance	8-7
Compliance Checks.....	8-9
Operational Tube Ranges.....	8-9
Construction.....	8-9
Safety Measures.....	8-11
Communications	8-11
Maintenance	8-11

Chapter 9 - The Baffle Range

Design	9-1
Situation.....	9-1

Chapter 10 - The Grouping and Zeroing Range

Range Danger Areas	10-1
Siting.....	10-1
Range Floor	10-1

Firing Points.....	10-1
Construction.....	10-2
Communication.....	10-2
Maintenance	10-2
Compliance Checks.....	10-2

Chapter 11 - The Gallery Range (Imperial and Metric)

Danger Areas.....	11-1
Design	11-4
Construction.....	11-4
Stop Butt.....	11-4
Markers Gallery	11-6
Mantlet.....	11-7
Target Store and Workshop.....	11-8
Range Floor	11-8
Firing Points.....	11-9
Communications	11-9
Maintenance	11-9
Compliance Checks.....	11-10

Chapter 12 - The Converted Gallery Range and Electric Target (Limited Danger Area) Range (Read in conjunction with Chapter 11)

Conversion Construction	12-1
General.....	12-1
Mantlet.....	12-2
Stop Butt.....	12-3
Targetry	12-3
Control Building	12-4
Electricity Supply	12-4
Communications	12-5
Maintenance	12-5
Compliance Checks.....	12-6

Chapter 13 - The Electric Target Range

Danger Areas.....	13-1
Design	13-1
Construction.....	13-2
General.....	13-2
Target End.....	13-2

Range Floor	13-3
Control Building	13-3
Firing Points	13-4
Electricity Supply	13-5
Communications	13-5
Maintenance	13-5
Compliance Checks	13-6

Chapter 14 - The Individual Battle Shooting Range

Danger Areas	14-1
Design	14-2
Construction	14-2
Targetry	14-2
Firing Lanes	14-3
Control Building	14-3
Services	14-4
Communications	14-4
Maintenance	14-4
Compliance Checks	14-5

Chapter 15 - Live Firing Tactical Training Range and Close Quarter Battle (Rural) Range

Danger Areas	15-1
Design	15-1
Construction	15-2
General	15-2
Targetry	15-2
Firing Area	15-3
Firing Positions	15-3
Supporting Structures	15-3
Communications	15-4
Maintenance	15-4

Chapter 16 - The Mechanised Moving Target Trainer Range

Range Danger Areas	16-1
Design	16-1
Construction	16-2
Target Line	16-2
Markers Bunker	16-3

Firing Points.....	16-3
Electricity Supply	16-3
Communications	16-3
Maintenance	16-4
Compliance Checks.....	16-4

Chapter 17 - MOD Test, Evaluation, Research and Proof (TERP) Ranges

General.....	17-1
Governance	17-2
Danger Areas.....	17-5
Design	17-5
Air Danger Areas (ADA)	17-5
Communications	17-6
Radio Frequency (RF) Operating Licences & RFDEW Trials	17-6
Meteorological (MET) Services.....	17-7
Authority and SME Tasking Process (DE&S TERP Activities).....	17-7
Trial Process.....	17-8
Laser Trials	17-9
Remotely Piloted Air Systems (RPAS)/ Uncrewed Aircraft Systems (UAS)	17-11
Air-to-Surface Engagements.....	17-11
Air Ranges.....	17-11
MOD Staff Operating Commercial Ranges.....	17-12
Safeguarding	17-12
Environment.....	17-13
Noise	17-14

Chapter 18 - Grenade Ranges

Range Danger Areas	18-1
Design	18-1
Construction.....	18-2
Range Floor	18-2
Range Buildings.....	18-2
Communications	18-3
Maintenance	18-3
Compliance Checks.....	18-4

Chapter 19 - Mortar Ranges

Range Danger Areas	19-1
Construction.....	19-1

Communications	19-2
Maintenance	19-2

Chapter 20 - Infantry Anti-Tank Weapon Ranges

Section 1 NLAW	20-1
Range Danger Areas	20-1
Siting	20-2
Construction	20-2
Tactical Firing	20-3
Section 2 JAVELIN	20-3
Range Danger Areas	20-3
Communications	20-3
Maintenance	20-3

Chapter 21 - Armoured Fighting Vehicle Weapon Systems

Range Danger Areas	21-1
AFV WS Fixed Arc Range	21-1
Design and Construction	21-1
Static Ranges	21-1
Battle Runs	21-2
Live Firing Tactical Training	21-2
Range Infrastructure	21-3
Communications	21-3
Maintenance	21-3

Chapter 22 - Air Rifle Ranges

Range Danger Areas	22-1
Design	22-1
Definition	22-1
Existing Indoor Rimfire Ranges	22-1
Indoor Ranges	22-2
Range in a Vehicle	22-3
Tent Range	22-3
Open No Danger Area Ranges	22-3
Stop Butt Height	22-3
Firing Outdoors	22-4
Communications	22-4
Maintenance	22-4
Compliance Check	22-5

Chapter 23 - Weapon Launched Grenade Ranges

Range Danger Area.....	23-1
Siting.....	23-1
Construction.....	23-2
Communications.....	23-3
Maintenance.....	23-3

Chapter 24 - Targetry

Provision.....	24-1
Infantry Target Systems.....	24-2
Armoured Fighting Vehicles (AFV) Target Systems.....	24-4
Targets and Accessories.....	24-6
Target Holdings.....	24-7
Maintenance.....	24-8

Chapter 25 - Control of Hazardous Substances in Indoor Range

Hazards.....	25-1
UK Regulations.....	25-3
Assessment.....	25-5
Air Monitoring.....	25-5
Responsibilities.....	25-6
Range Design.....	25-7
Design.....	25-7
Air Extraction.....	25-9
Inspection, Cleaning, Hygiene, Records and Signs.....	25-9
Inspection.....	25-9
Range Cleaning.....	25-10
Health and Hygiene.....	25-13
Retention of Documentation.....	25-13
Safety Signs.....	25-14
Annex A - Guidelines for Deep Cleaning Contract Small Arms Ranges.....	25A-1

Chapter 26 - Control of Noise from Small Arms Ranges

Environmental Noise (Noise Nuisance).....	26-1
Background.....	26-1
Noise Source.....	26-2
Natural Dissipation.....	26-3
Natural and Engineering Controls.....	26-3

German Range Noise Baffle Solutions26-5
Annex A - Measurements of Peak Pressure Levels (dB) and Pulse Duration
(milliseconds) for Typical Infantry Weapon Systems 26A-1

Chapter 27 - Weapon Unloading Facilities

Unloading Facility Construction27-1
Proprietary Unloading Facilities27-2
Design27-2

Chapter 1 - Range Grouping

The aim of this chapter is to outline the procedures for the justification, authorisation, funding, construction, and site selection of, MOD ranges.

1-01. Grouping of Ranges. MOD ranges may be, or are regarded as being, one of the following:

- a. **Permanent Training Range.** A Permanent Training Range (PTR) will be in a barracks or on a training area. The range can be indoor or outdoor (open), static or mobile, may require specific construction, and can be grouped to form a range complex.
- b. **Temporary Exercise Range.** A Temporary Exercise Range (TER) is one created for the duration of an exercise or for a specified period. The range will be located on land cleared for a specified use with the appropriate authorities and made safe for firing with its own authorised RDA trace defining the restricted area. DSA 03. OME Part 3 Volume 1 Part 2 Chapter 5 provides guidance on the conditions under which a TER may be established.
- c. **Operational Theatre Range.** Where the operational situation permits, an Operational Theatre Range (OTR) may be established to enable personnel deployed on operational duties to test and zero their weapons and to conduct training for operations. It is accepted that in the early stages of an operation full implementation of policy given in this document may not be practicable requiring a risk-based assessment by the operational commander. However as soon as reasonably practicable policy is to be adopted and when the operation is in the enduring phase full implementation is to be adhered to.

Permanent Training Ranges

1-02. **Justification.** Permanent Training Ranges (PTRs) are initiated by a Statement of Requirement (SOR), approved by the Top-Level Budget (TLB) and licenced by Defence Ordnance, Munitions and Explosives Safety Regulator (DOSR).

1-03. **Authorisation.** New PTRs are to be built to the design criteria or as detailed in this document. Those involved in the planning and construction of a PTR are to involve RITT from the outset.

1-04. **Construction.** Before any construction starts those responsible shall consult with RITT to ensure any construction, refurbishment, or change does not put at risk the safe place. The details of the range construction, refurbishment, significant change¹ or decommissioning of an existing range is to be the subject of a Board of Officers which is recorded on MOD Form 1057 Series. Prior to constructing a PTR, consideration should be

¹ A significant change is any alteration or addition to a range that changes the purpose of its original intended use or the addition, removal or replacement of any permanently fixed structure or permanent range furniture, e.g. the introduction of overhead fire towers or urban structures onto a range to allow OBUA training. Temporary shoot through structures may be classed as targetry on LFTTAs.

given to the need for services, ancillary buildings, and other structures. These include, but are not limited to:

- a. Troop shelter.
- b. Target store and workshop.
- c. Toilets.
- d. Water supply and drainage.
- e. Power supply.
- f. Security and screen fences, barriers, lookout posts, signs, notices, flagpoles, and lights.
- g. Range roads and parking.
- h. Ammunition points.
- i. Communications.

Environmental Issues

1-05. **Environmental Planning Issues.** When selecting the site for a range, the visual and acoustic effects on the environment and the public, as well as any measures to reduce those effects, are to be assessed. This is particularly important for sites; in or near National Parks, areas, used for public leisure, inhabited areas, and any sensitive buildings such as hospitals. The relevant TLB environmental authority is to be consulted at an early stage to ascertain whether the area chosen for a PTR is a conservation designated area or a heritage site, and whether there may be planning authority sensitivities which require consultation with statutory Bodies. Advice on noise can be obtained from the Area Health Safety and Environmental Groups for the Royal Navy / Royal Marines (RN / RM), the Division or Formation Environmental Health Officer (EHO), Army, the Environmental Noise Officer (ENO) Royal Air Force (RAF) Health Monitoring Team (HMT) and the Central Budgets Security, Safety and Business Continuity - Safety, Health and Environment (CBSSBC-SHE) as applicable.

1-06. Environmental Health Issues. For each new and existing range, the following issues are to be considered. Lead and Carbon Monoxide issues are covered in more detail in Chapter 25.

- a. **Lead.** Lead contamination down range on open ranges where most rounds are not captured by a stop butt. This will involve the retention of MOD Form 906 Series records to maintain record of the number and type of ammunition fired.
- b. **Carbon monoxide.** Indoor ranges including tube ranges without assisted ventilation, all indoor test ranges and enclosed firing point ranges must consider the presence of carbon monoxide.
- c. **Noise.** Consideration is to be given both to the noise that affects the range users and those who are in the vicinity of the range. Noise levels affecting the range users are typically controlled by provision of hearing protection, refer to Pamphlet 21.

Noise levels that may affect those in the vicinity of the range may be controlled by many factors described in Chapter 26.

1-07. **Byelaws.** In the UK, DIO (Land Management Services) are to be consulted on the need for byelaws to prohibit unauthorised persons entering Sea, Land and Air Danger Area, to protect members of the public from the hazards arising from the military use of the range and to prevent public interference with the operation of the range.

1-08. **Boards of Officers.** Detailed retirements and instructions for Siting Board, Range Acceptance Board, Range Transfer and Range Closure are contained in DSA 03. OME Part 3 Volume 1 Part 2 Chapter 5.

1-09. **Provision Procedures.** The procedures for providing a new range are outlined for range staff, DOSR TL, Range Approving Officer (RAO) and Range Administering Unit (RAU) in Annex A to this Chapter.

Temporary Exercise Ranges

1-10. **Introduction.** The policy for establishing a Temporary Exercise Range (TER) is contained in DSA 03.OME Part 3 Volume 1 Part 2. TERs are usually contained partially or wholly within LFTTA. Live fire training structures constructed for the exercise are to follow guidance provided in this DCOP and in Pamphlet 21. The requirements of an LFTTA are set out in Chapter 15.

1-11. Authorisation.

a. **Existing LFTTA.** When a TER is set up within an existing licenced LFTTA so that the whole of the range and the associated Range Danger Area (RDA) or Weapon DA (WDA) are contained within its boundary, no additional authorisation is required for its construction or use for authorised weapons, ammunition, and practices.

b. **New Sites.** When the requirement is for a TER where RDA or WDA is not wholly within an existing LFTTA, specific instructions for the use of the range are to be included in the exercise instructions after a risk assessment. The exercise reconnaissance should provide sufficient data for detailed design and safety advice to be provided to the appropriate RAO HQ. Advice for each TER can, where appropriate, be provided by RITT. When doubt exists about topography, structures or the exact location of the range or the associated RDA, RITT should, under normal circumstances, carry out a survey to determine potential ballistic compliance issues and where necessary 2 LODA (LTAR, RAF ESIT, RNRSO, EM) Small Arms School Corps (SASC) and Weapons Engineering and Safety Operating Centre (WESCOE), or RSIT advice should be sought. Environmental issues will also have to be addressed. The appropriate RAO responsible for the exercise is required to approve firing practices in accordance with Operational Shooting Policy (OSP).

Operational Theatre Range

1-12. **Requirement.** The policy for establishing an OTR is contained in DSA 03.OME Part 3 Volume 1 Part 2. It is often necessary for troops deployed on operations or emergency duties to zero and test other weapon systems, and to train. The situation is not predictable, but it is most likely that units will require a 'No Danger Area' (NDA) range. There may also be a requirement to train as a unit which could involve firing on an LFTTA. The

responsibility for approving the range use on operations and emergency tours lies with the RAO. In many cases ranges set up by foreign armies can be used, but these need to be checked against criteria set out in this DCOP.

1-13. Whenever possible full TER procedures are to be followed. Proper siting and construction are essential to the safe operation of an NDA range and RE support is desirable from the outset. Where possible a full survey of the area should be conducted before the range is constructed and / or authorised. The findings and recommendations of any survey are to be sent to the authorising HQ for expert advice. The proposed range design should, where possible, be in accordance with the relevant chapter of this DCOP. When the requirement is for a LFTTA, the range can be identified from a map study although a physical check by the most accurate and appropriate means must be carried out to ensure that map details are correct. The RAO shall approve all ranges with or without full authorisation procedures.

Sea and Air Danger Areas

1-14. **Sea Danger Areas.** RITT can provide the extent of land ranges and sea dangers areas. This information is promulgated through the Fleet Operating Orders to the Hydrographic Office (HO) for entry onto the HO database and eventually onto maritime charts.

1-15. **Air Danger Areas.** The limits of Air Danger Areas (ADAs) are promulgated in the [UK electronic Integrated Aeronautical Information Package \(IAIP\)](#), published by National Air Traffic Services, Aeronautical Information Service (NATS AIS). The eAIP is subject to a 28 - day amendment publication cycle. Information can be found in Part 2 (En-Route), Section 5 (Navigation Warnings), ENR 5.1 (Prohibited, Restricted & Danger Areas).

Works Procurement and Refurbishments

1-16. **Range Safety Criteria Check.** Before funds are committed to any new range, major refurbishment, or alteration of an existing range, plans and details shall be passed to 2 LODA / RITT to confirm that the proposal complies with current range safety criteria. Routine maintenance need not be referred to RITT unless the works organisation has safety or suitability concerns. Any new build and major alteration to range ballistic structures is to have RITT approval.

Facilities Management

1-17. **Compliance to Current Legislation.** All ranges are subject to a biennial works inspection as set out in DSA 03.OME Part 3 Volume 1 Part 2 Chapter 7. The RAU shall ensure that the local works inspection of ranges include all regulatory checks and where necessary checks by Authorised Personnel.

Sustainable Development

1-18. **Sustainable Range Development and Use.** Range development shall provide safe effective operational training facilities and ensure that the effect on range structures and the environment is minimised. Designers are to specify low maintenance solutions and where possible, lead bullet debris is to be captured for recycling.

Annex A to Chapter 1

Procurement of a New Range – Range and Training Staff Guide

This check list highlights issues related to ranges. A typical check list is shown below.

Project Identification and Initiation

Ser	Stages	Action	Appointment / Branch
1	Need for new range identified: a. Training objectives / type of training b. Predicted usage & user units. c. Range type, capacity & targetry d. Land area & DA requirements		Establishment, Service HQ
2	Identify site options: a. User unit locations b. Available range locations c. Professional & technical appraisal d. Initial survey e. Local Planning Authority (LPA) restrictions f. Timescale requirement g. Targetry h. Any other site-specific Requirements, e.g. Environmental, Historical etc.	Siting Board (DSA 03.OME Part 3 Volume 1 Part 2)	RAO RAU RITT Regional DIO-LMS
3	Siting Board: a. Confirm site options. b. Confirm & set priority.		RAO RAU RITT Regional DIO-LMS
4	Assess Rough Order Cost (ROC) including targetry.		Service HQ

Project Definition

Ser	Stages	Action	Appointment / Branch
1	Project brief		Service HQ Regional DIO
2	Preliminary & detailed design, & technical approvals.	Design Technical Approval	Regional DIO RITT Consultant

Construction

Ser	Stages	Action	Appointment / Branch
1	Consultation, planning, site meetings		Regional DIO
2	Confirm technical approvals. Periodic Reviews		Regional DIO RITT
3	Acceptance & Range Boards	Board of Officers	Service HQ RAO RAU Regional DIO
4	Issue MOD Form 905 / 905T	DSA 03.OME Part 3 Volume 1 Part 2	DOSR TL RAO 2 LODA

Chapter 2 - Range Design Criteria and Specifications

The aim of this chapter is to outline details of the design and specifications applicable to all MOD Ranges.

Introduction

2-01. **Categorisation Of Criteria.** Criteria provided in this, and other Chapters are categorised to aid those involved in provision of safe place in understanding the implications of those criteria on the safety of a range. The categories used are summarised below:

- a. **Critical (C).** That which will affect the ballistic safety or effective use of the range.
- b. **Standard (S).** That which meets current safety requirements but is not necessarily critical to the ballistic safety. This criterion provides the standard solution which will be safe for authorised practices at any location. Unless stated otherwise all detail in this document are to be taken as Standard. Standard dimensions are to be implemented where practical unless an alternative is approved by RITT.
- c. **Typical (T).** That which is provided for guidance only indicating a typical solution.

2-02. **Identification of Critical, Standard and Typical Requirements.** All details in the respective range chapters represent the authorised Standard to be adopted where practical. Those elements that may be provided in many forms will be designated as Typical. As the margins of safety incorporated in the Standard are wide, a range element that fails to meet this Standard is unlikely alone to make the range unsafe. Elements that do not comply with the Standard are non-conforming and may be non-compliant. They should be assessed to determine if the level of safety is affected. Critical dimensions are inherent in the safety or use of the range and are to be achieved unless a waiver, or ARS, is in place.

2-03. **Range Compliance Checklist.** All ranges must achieve compliance for critical criteria and should achieve compliance for standard criteria. A range compliance checklist is provided at the end of each range type Chapter. In addition to these there may be site specific compliance checks. The checklist has been produced as a 'Guide' to assist Range Inspectors, Range Administering Units (RAU), Project Sponsors (PS), Project Managers (PM), Designers and Contractors. The aim of the checklist is to provide guidance and therefore highlight areas that will be subjected to checks to confirm compliance of a range. Designers submitting plans to RITT for compliance checks are to include all the detail listed and any other relevant information. The checklist is not exhaustive; it is an aid to assist achieving compliance with this document.

Range Safety Terminology

2-04. Understanding range safety terminology is critical to provision of safe place and is therefore defined in this chapter. This section is laid out in alphabetical order.

2-05. **Air Danger Area.** An Air Danger Area (ADA) is the airspace above a range which has activities dangerous to the flight of aircraft. Ranges can have permanent or temporary notified ADA. Airspace below 500ft is not controlled by the Civil Aviation Authority (CAA) however, light aircraft, helicopters and military flights may use this airspace.

2-06. **Air Danger Height.** The Air Danger Height (ADH) is the maximum height above ground level (AGL) which a hazard may exist (see Notes 1 and 2). Table 2-1 gives ADH for SA ammunition¹.

2-07. **Ammunition Danger Area.** The area on or behind a firing point which has a danger area and access is controlled and personnel are to be fully protected. See Weapon / Range Danger Area Template.

2-08. **Angle Of Sight.** The Angle of Sight (AoS) is the acute angle between the Line of Sight (LoS) and the horizontal plane. (For details of further ballistic angles see Fig 2 - 6 and DSA 03.OME Part 3 Volume 2).

2-09. **Approved Range Status.** A range which varies from the design and build criteria specified for its type in DSA 03.OME Part 3 Volume 2. However, the resultant risk is assessed not to exceed the level for a Compliant Range of the same type or similar. Approved Range Status (ARS) is requested by the 2 LODA based on advice / recommendation offered by the appropriate SMEs and submitted to the DRSCWTWG for endorsement and sign-off by the Regulator. Where a full RDA cannot be applied, it may be necessary for WESCO to use the Weapon Danger Area Laboratory (WDALab) to assess the level of safety of the range before ARS can be authorised. This advice may also be used to support a waiver (see paragraph 2-40). A review of the ARS is to be carried out during the triennial inspection and is to be recorded in the MOD 907A and DOME database.

2-10. **Automatic Marking System (Ams).** This is a system which detects, indicates and records shots on or close to a target. Usually, these systems comprise of several elements including, but not limited to; target and lifter mechanism, shot detector system, shot indicator system (which can be remote from the target and detector), and recording system (which, again can be remote from the target and detector). An example of an AMS is the Small Arms Range Targetry System (SARTS) by Lockheed Martin.

¹ Reference OB ML 04/98. For weapon systems not listed in the OB ML refer to the relevant Weapon Safety Case

Table 2-1 - SA Ammunition ADH

(a) Ser	(b) Ammunition	(c) Constructed LDA / FDA ranges No exposed surfaces	(d) Constructed LDA / FDA ranges Exposed surfaces	(e) FDA / LFTTA ranges QE<150 miles	(f) FDA / LFTTA ranges QE 150-1250 miles	(g) Remarks
1	5.56mm Ball L2A2	500ft	1000ft	1000ft	8000ft	Rifle
2	5.56mm Tracer L1A2, L110	500ft	1000ft	1000ft	8000ft	Rifle
3	7.62mm Ball	750ft	1500ft	1500ft	8800ft	
4	7.62mm Tracer	1500ft	1500ft	2000ft	8800ft	
5	12.7mm Ball	Not used	Not used	3000ft	14300ft	Incl.50"
6	12.7mm Tracer	Not used	Not used	4000ft	14300ft	Incl.50"
7	30mm	Not Used	Not Used	Soft 4500ft	Hard Target 9500ft	
8	9mm Ball	500ft	500ft	1000ft	3200ft	
9	0.22in Ball	500ft	500ft	1000ft	3200ft	
10	0.22in Tracer	500ft	500ft	1000ft	3200ft	
11	8.6mm Ball	500ft	500ft	3000ft	3000ft	Note 4
12	4.6mm Ball	500ft	500ft	1000ft	1500ft	
13	Shotgun Slug	500ft	500ft	500ft	5000ft	Combat Shotgun
14	Shotgun Buckshot	500ft	500ft	500ft	6000ft	Combat Shotgun
15	GMG (all natures)	3000ft	3000ft	3000ft	3000ft	
16	Grenade	Not used	200ft	Not used	Not used	Standard grenade range

Notes (Table 2-1):

1. The ADH is either the highest point of an aimed shot measured from the firing position or its maximum ricochet height.
2. An ADH is measured in feet (ft) AGL. Altitude is measured in ft Above Mean Sea Level (AMSL).
3. For High Elevation Fire (HEF) (QE 150 - 1250 mils, Fig 15 - 3) the ADH provided should be applied when the Cone of Fire is not captured by the ground.
4. 8.6mm ammunition may be fired with an ADH of 500ft on LFMT ranges provided that the sniper progression of training and authorised sniper practices is adhered to.

2-11. **Backsplash.** Backsplash is fragmentation, or target debris, produced projectile impact and thrown backwards. Anti-backsplash curtains (designs and materials to be endorsed by RITT; Linatex, RUTEC and Safeblast), set clear of the impact surfaces prevent backsplash thus enabling closer engagement. Where no such protection is provided the following backsplash distances apply:

Table 2-2 – Backsplash Zone (Safety Distance)

(a) Ser	(b) Weapon	(c) Fragment / Earth Throw Distance Hard Tgt (m)	(d) Fragment / Earth Throw Distance Soft Tgt (m)
1	Air gun	Refer to Chapter 22	
2	Rimfire, centrefire pistol and carbine	22	10
3	Centrefire rifle	50	22
4	7.62 mm tracer	125 ⁵	125 ⁵
5	8.6mm	300	-
6	30mm RARDEN PRAC and APDS	400	400

Notes (Table 2-2):

1. The Backsplash Rule is described in detail in Pamphlet 21.
2. Backsplash from well-maintained sand stop butts does not exceed 5m (see Note 5 below). For NDA and LDA ranges authorised practices may be undertaken down to 3m from the targets and a minimum of 5m from the well-maintained bullet catcher and assessed by RITT. A well-maintained stop butt and bullet catcher is one where no bullet debris is permitted to build up around the MPI and any scooping is raked over after each day's use.
3. Control measures for backsplash on LFTTAs is covered in Pamphlet 21.
4. Backsplash zone for MDP practices using MP7 and 4.6mm steel ammunition against well maintained bullet traps does not exceed 10m.
5. Backsplash from 7.62mm tracer is 125m from all hard structures and sand structures with front faces of less than 56° and heights more than 2m. On compacted earth slopes the 7.62mm tracer rounds are normally captured without ricochet.
6. Backsplash from a well maintained granulate rubber bullet catcher does not exceed 3m. Specialist Users refer to RITT.

2-12. **Burst Safety Distances.** Burst Safety Distances (BSD) are hazard distances away from fragmenting ammunition.

2-13. **Clear Range Procedure.** A procedure authorised by the Range Administering Unit (RAU) and applied by the user unit to ensure that the Range Danger Area (RDA) is clear of unauthorised persons before firing commences and that it remains clear throughout the time firing is in progress. The procedure includes provision for the timely cessation of firing before it poses a risk of hazard to an intruder in the RDA. Refer also to DSA 03.OME Part 3 Volume 1 Part 2 for more detail.

2-14. **Clear Vision Line.** Clear vision lines are projected from above and below the firer to the target to ensure there are no distracting protrusions within the firer's peripheral field of vision in all firing postures (see Fig 3 - 3). The extent of clear vision required is set out in the relevant sections and chapters of this DCOP. Clear vision lines are established to ensure that:

- a. The risk of backslash to the firer is eliminated.
- b. An unrestricted view to the target and its immediate surround is achieved and maintained.
- c. The physical build of individual firer accounted for.

2-15. **Cone Of Fire.** The Cone of Fire (CoF) is the distribution of fired projectiles within a margin of error in the vertical and horizontal planes. For design purposes the CoF figs in Table 3 below are applied around each Line of Sight (+elevation, - depression and +/- azimuth). The CoF accounts for acceptable deviation caused by errors associated with the firer and machining or manufacturing tolerances and allows an additional margin for unacceptable firer error. Table 3 lists the authorised SA CoF applicable on SA ranges.

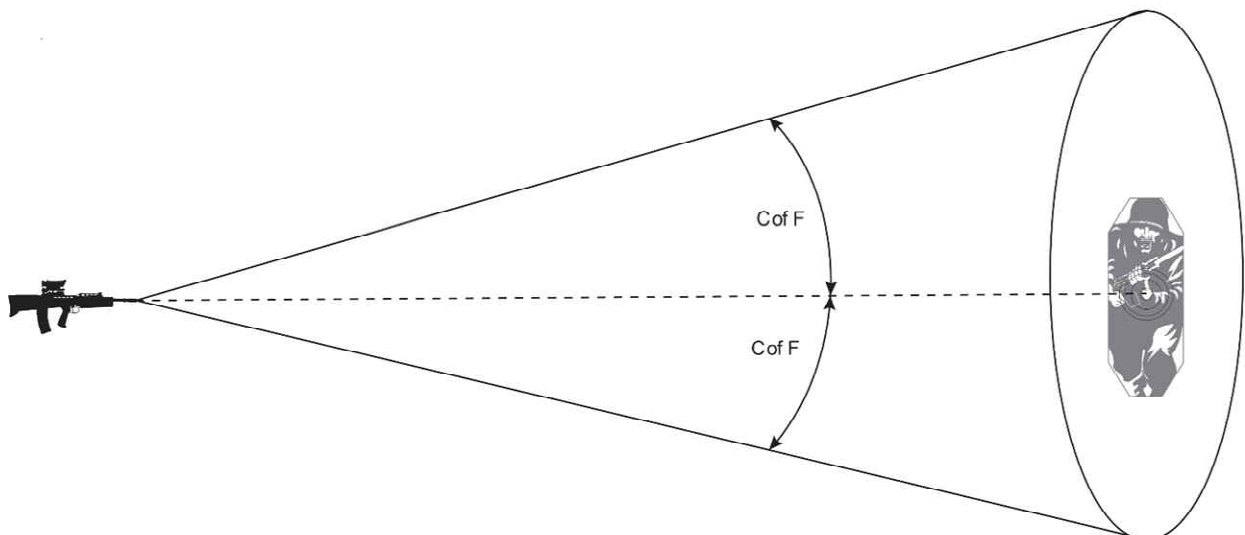

Fig 2 - 1. Cone of Fire around Point of Aim

**Table 2-3a - Authorised SA Cones of Fire to be Applied on SA Ranges:
Live Fire Marksmanship Training (LFMT)**

Ser	Practice	Engagement Type	CoF	CoF
		SS = Single Shot A = Automatic	Azimuth (mils)	Elevation (mils)
1	NDA/LDA/FDA Ranges (Notes 1 & 2) Rifle / Carbine (Note 6) Static to Static	SS	±40	± 40
		A	±60	± 40
2	Static to Moving	SS	±60	±40
		A	± 90	±40
3	Moving and moving vehicle smooth track to Static or Moving	SS/A	± 120	±60
4	Pistol (Note 5 & 6)	SS/A	± 135	±135
5	Combat Shotgun - Slug Combat Shotgun - Shot	SS	+80	+80
		SS	+80	+200

**Table 2-3b - Authorised SA Cones of Fire to be Applied on SA Ranges:
Live Fire Tactical Training (LFTT)**

Ser	Practice	Engagement Type	CoF	CoF
		SS = Single Shot A = Automatic	Azimuth (mils)	Elevation (mils)
1	Static to Static	SS/A	± 60	±60
2	Static to Moving	SS/A	± 90	±60
3	Moving and moving vehicle smooth track to Static or Moving	SS/A	± 120	±90
4	Moving Vehicle rough terrain to Static or Moving	SS/A	±150	NA (Note 4)
5	High Elevation Fire (HEF)	SS/A	±150	NA (Note 4)
6	Pistol (Note 6)	SS	±250	±190
7	Combat Shotgun - Slug Combat Shotgun - Shot	SS	+80	+80
		SS	+80	+200

**Table 2-3c - Authorised SA Cones of Fire to be Applied on SA Ranges:
Restricted Practices (Reduced CoE)**

Ser	Practice	Engagement Type	CoF	CoF
		SS = Single Shot A = Automatic	Azimuth (mils)	Elevation (mils)
1	Target shooting Rifle / Carbine (Note 3) Supported only Static to Static (Note 3)	SS	± 21.5	± 21.5
2	Target shooting Rifle / Carbine supported only Static to Moving (Note 3)	SS	± 40	± 21.5
3	Sniper practices (snipers who have completed initial sniper training only).	SS	± 12	± 12

Notes (Tables 2-3a-c):

1. LDA / FDA ranges include all open ranges that have DA limited by construction, or a combination of construction and QE.
2. On LDA ranges automatic fire is restricted to burst fire from bipod / tripod mounted 5.56mm and 7.62mm weapons. Unsupported Automatic Rifles may only be burst fired on a FDA range with a DA of 2900m or greater.
3. The reduced CoF recommended by WESCO may be applied only under the following conditions:
 - a. Use is restricted to competent marksmen authorised in writing by the risk owner, using a rifle zeroed or check zeroed at not more than 100m each time the weapon is brought onto the range.
 - b. The reduced CoF of 21.5mils is approved only for single shot supported shooting practices.
4. Serials 9 & 10 are conducted on ranges with a full energy template applied and hence the CoF, in elevation, is contained regardless of QE.
5. Pistol firing one handed - the pistol CoF only remains valid when the appropriate progression of training has been followed and the required standards have been met. The maximum permitted engagement distance for firing one handed is 10m.
6. MP7 4.6mm ammunition - The MP7 is to be treated as a carbine for the purposes of CoF when firing it with the butt extended. When fired with the butt folded it is to be treated as a pistol for Cone of Fire purposes.

2-16. **Danger Area / Zone.** The Danger Area / Zone (DA / Z) is the space in which there may be a hazard which could result in harm to personnel, equipment, or property.

Note: The space is defined as weapon or range specific i.e. Weapon DA / Z (WDA) or Range DA / Z (RDA).

2-17. **Danger Area Template.** A Danger Area Template is a technical drawing worked to a given scale and produced on appropriate material for conventional application. A Danger Area (DA) Template can be produced for a single Weapon type (WDA Template) or a Range (RDA Template).

2-18. **Danger Area Trace.** On a Live Firing Tactical Training Area (LFTTA) the user will be issued with or required to construct a WDA template. Using the appropriate template, they are to plan the exercise and submit the RDA trace to Range Control. The size of the area, the ground conditions, and arcs of fire available will determine the size and scope of the LFTT exercise which can take place.

2-19. **Design Approval.** Design approval is the formal act of authorisation in document form, by the Responsible Authority that the design meets the stated requirements and is suitable for MOD use with or without limitations. For range works and projects this will be the responsibility of those responsible for Works and Project delivery.

2-20. **Design Authorisation.** Design authorisation is the order or direction to do something to meet stated requirements by the branch or establishment responsible for doing so i.e. by the Responsible Authority. The responsibility may be more limited e.g. Design or Technical Authorities. Their appointment and limitations are authorised by the

Responsible Authority². For range works and projects this will be the responsibility of the Property Manager or Project Sponsor (PS).

2-21. **Design Certification.** Design certification is a signed statement by a qualified person that the design wholly or partially meets or complies with the approved specification(s), which includes legislation. RITT will undertake design review to confirm that it meets the directed criteria before being constructed. On completion of construction RITT will undertake compliance survey of the range infrastructure.

2-22. **Hard Target.** Hard target refers to all materials which when impacted will not deform, move, or break up. When hard materials are exposed to the firer, the additional DA wings are to be applied (see Fig 15 - 2). See also Soft Target paragraph 2-41.

2-23. **High Elevation Fire.** High Elevation Fire (HEF) is fire at a variable vertical firing angle for engaging targets where the CoF is elevated so that no portion of it is captured by the ground within a general firing angle of 150 - 1250mils. For SA it denotes Air Defence (AD) shooting.

2-24. **Hill Background.** A hill background exists where the ground immediately behind the targets rises to form an obstacle beyond which no projectile hazard is predicted, see Fig 2 - 10).

2-25. **Impact Area / Zone.** An impact area / zone is a space authorised (applied permanently or at the time of firing) in which specified weapons impact, detonate, break up or function. The space must be large enough to contain ricochet but have its edge no closer to the DA / Z boundary than the authorised fragment BSD or other bursting weapon hazard distance. Access to the impact area / zone must be physically controlled as directed by the Range Authorising HQ. Additional controls may be required due to the possible presence of blinds. For a full description of impact areas (see paragraph 2-108).

2-26. **Jump.** Jump is the vertical component of the acute angle between the muzzle axis before firing and the line of departure. It can be positive or negative, depending on the weapon.

2-27. **Line Of Fire.** The Line of Fire (LoF) is an imaginary straight line from the barrel of the weapon delivery system to the target. The LoF is used by range designers to ensure safety from all firing positions. The distinction between Line of Sight (LoS) and LoF is critical when shooting from the prone position and for sniper fire from inside a building as although the sight to target is clear, the Line of Fire may not be. For example, the Rifle optical sight is 90mm above the centre line of the barrel. (Fig 2 - 2).

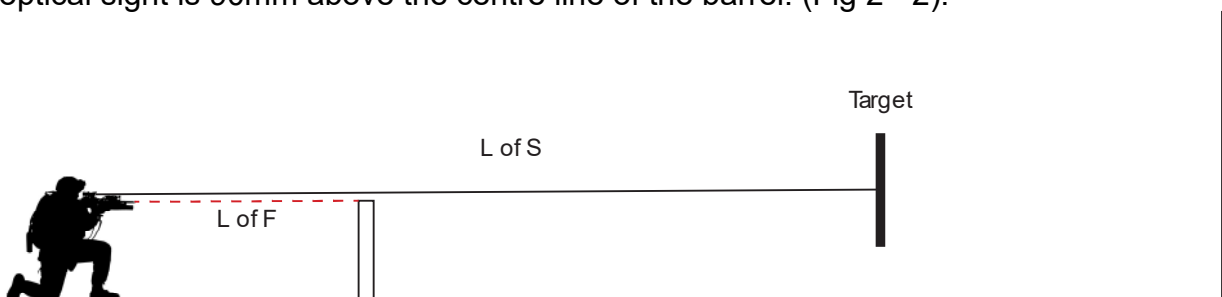

Fig 2 - 2. Line of Fire / Line of Sight

² Defence Standard (DEF STAN) 05-10

2-28. **Line Of Sight.** The LoS is a straight line passing through the aiming device (sight) of the delivery system to the point of aim on the target so that the firer can see the target he is engaging. (Fig 2 - 2).

2-29. **Managed Non-Compliance (MNC).** Where ranges have some degree of non-compliance to the standard criteria for the range type, RITT advice is to be sought to confirm the range is suitable to be considered for MNC. Although different from those illustrated in this DCOP, they will conform to all the safety critical elements described in the respective chapters. Where RITT considered that the non-compliance will not increase the level of risk on the range, the RAO will be notified of this advice by the issuing of MNC. The areas detailed in the advice, where the range falls short of the criteria shall be recorded on the DOSR database, MOD Form 1057 series and a copy is to be kept in the range file, to maintain a written audit trail. Such non-conformities may include construction tolerances, accuracy of measurement, and RITT endorsed variation of standard dimensions. It is the responsibility of the 2/3 LODA to confirm that there has been no change to the range criteria in accordance with the MNC, during the annual range inspection and is to be recorded on the MOD 907A.MNC (infrastructure) use is restricted to competent firers authorised in writing by the risk owner, using a zeroed rifle and not more than a range of 100m each time the weapon is brought onto the range

2-30. **Military Measurement.** The angle of military measurement is a mil which subtends 1mm at 1m and 1m at 1km and is approximately $1 / 6400$ of a circle. This simple unit of measurement aids setting out and estimating angles and distances in the field.

2-31. **Muzzle Energy (Me).** The ME is the kinetic energy of a projectile at the muzzle of the weapon system. The ME (joules) = $\frac{1}{2}MV^2$ (m = projectile mass in kg, V = MV in m/s).

2-32. **Muzzle Velocity (Mv).** MV is the speed of a projectile as it leaves the barrel.

2-33. **Prepared Impact Area.** Where exploding ordnance has a grazing fuse that may not ignite in soft ground, the area around the target is prepared with stone or gravel. The extent of the hard surface will depend on the predicted weapon and aimer error.

2-34. **Quadrant Elevation.** The Quadrant Elevation (QE) is the angle between the horizontal plane and the axis of the bore when laid (sighted). (See Fig 2 - 6). For the purposes of range design in this publication the following sub definitions are provided:

- a. QE TCH = QE to the Target Centre Height (Physical point on arrange that can be measured).
- b. QE Act = QE TCH + CoF.
- c. QE Max = QE Restriction applied.

2-35. **Range (Zone).** A range is a space controlled, authorised and normally equipped for hazardous firing (weapons or lasers).

2-36. **Range Approving Officer.** The Range Approving Officer (RAO) is the Officer responsible for personally certifying the weapon systems, munitions and explosive stores which can be used on the range. Range Authorising Officer (RAO) refer to MoD 905 for both appointments X2 RAOs. Further information is contained in DSA 03.OME Part 3 Volume 1 Part 2.

2-37. **Range Danger Area / Zone (Also Known As Danger Area/ Zone).** The RDA / Z is the space within a range in which there may be a risk to personnel, equipment, or property from firing authorised weapons within specific arcs. The RDA / Z should be within the training area boundary. Access to and movement within the RDA / Z are controlled through Range Standing Orders (Range SO). RDA includes the ADA and is better described as Range Danger Zone (RDZ)³.

2-38. **Range Floor.** The range floor is the ground from the furthest firing point to the target (including any range construction intended for, or capable of, capturing correctly aimed shots or reducing ricochet) and left edge of left-hand firing position to the right edge of the right-hand firing position.

2-39. **Range Safety Waiver.** A range safety waiver is considered for a particular range that cannot be designated as a compliant, MNC or Approved Range due to range structure, layout, or danger area. The waiver provides written authorisation to permit continued use of the range when it does not meet the prescribed safety criteria. For OME regulatory waivers see DSA 02.OME regulations.

2-40. **Ricochet.** A ricochet is the change of direction and velocity, induced in a projectile, missile or fragment caused by its impact with a material. For high velocity ammunition design purposes ricochet is taken as 30° off soft targets and 45° off hard targets in elevation and azimuth. For low velocity ammunition the ricochet angles are taken as 15° off soft targets and 45° off hard targets. For specific range advice RITT may utilise data provided by WESCO from trials. Ricochet greater than 90° is regarded as backsplash (see paragraph 2-80).

2-41. **Soft Target.** Soft target refers to all materials which, when impacted at low angle (<30°), will deform, move, or break up. Note: a soft target impacted at a high angle remains a soft target. Water surfaces and ice are also classified as a soft target, though frozen ground may become hard enough to be classified as a hard surface dependent on the material and degree of freezing. See Hard target paragraph 2-22.

a. **Limited Danger Area (LDA) Ranges.** All LDA ranges must have 150mm of stone free soil on the range floor. Any banks must meet the specification within the relevant chapter e.g. mantlets.

b. **Full Danger Area (FDA) Ranges.** Where stones, or other hard objects, are not visible to the firer on an FDA range then they are not considered to be presenting any additional ricochet or backsplash potential. Stones which are visible, but loose i.e. if struck by a bullet the stone would move, are also considered to not present any additional ricochet or backsplash potential. Where stones are present on the range floor which are large or fixed, i.e. if struck by a round then the stone would not move, are visible, and present an irregular face then application of the hard target mitigation should be put in place. Any banks on the range must also apply these principles, except where engagement is closer than the soft backsplash distance, and the bank is in the cone of fire, in which case the bank must be as per a well-maintained bullet catcher.

³ Boundaries on land are to have appropriate control measures in place to warn the public and to deter access, for example, signs, fences, flags, lights and sentries. See also DSA 03.OME Part 3 Volume 1 Part 2. At sea buoys may have to be provided.

2-42. **Tangent Elevation.** Tangent Elevation (TE) is the angle between the LoS to the target and the axis of the bore.

2-43. **Template.** A template is an area into which direct fire and ricochet is expected to fall. It is produced as part of the weapon system safety case. See also RDA & WDA Template.

2-44. **Trace.** A trace is a drawing produced by a Planning Officer / Range Conducting Officer for a specific exercise to a given scale and produced on appropriate material for convenient application to a map.

2-45. **Type Standard.** All ranges are grouped as 'type' and a separate chapter in this document is allocated to each range type. Type Standards are a set of written documents held by RITT. These documents summarise the ballistic safety constraints to enable designers to produce site specific designs.

2-46. **Wdalab.** Weapon Danger Area Laboratory. A computer programme run by WESCO that simulates rounds fired on a range that produces a probabilistic assessment of where rounds fall given the site-specific ground features, weapons used and predicted cones of fire.

2-47. **Weapon.** A weapon is an object designed, used, or capable, of being used as an instrument for delivering ammunition which in turn inflicts harm to health, property, or the environment.

2-48. **Weapon Danger Area / Zone.** A WDA / Z is the space into which the weapons ammunition or it's fragments may travel, impact or function given normal firing conditions. The WDA / Z excludes low probability human and system errors.

2-49. **Weapon Danger Area Template.** A WDA template is a technical drawing of an approved DA for a single delivery means and a single target, projected on a specified LoF bearing, worked to a given scale on appropriate material for convenient application to a map.

- a. On a LFTTA the WDA template can be used to deduce a variable safe area by swinging the template within allocated arcs. The deduced safe area becomes a trace for the single weapon system. (See Pamphlet 21).
- b. Combining more than one WDA template produces a trace.
- c. RDAs and WDAs, and therefore the templates, require review. Unless a revised template has been approved in accordance with Service instructions, it must never be used for firing.

2-50. **Weapon Unloading Facility.** Weapon Unloading Facility (WUF) may be either static or transportable. All transportable units are proprietary designs.

Principles of Range Design, Maintenance, Operation and Decommissioning

2-51. **General.** The risk of a projectile leaving a range is minimised by a combination of design, training, maintenance, and control.

2-52. **Design Approach.** Range design parameters are based on historical evidence, advice from WESCO, the previous Ordnance Board Proceedings and Members Letters, DSA 03. OME Part 3 Volume 1 Part 2 and advice from RITT. WESCO have provided advice derived from scientific data generated from trials and considered opinion, based on appropriate ballistic and statistical calculations, and on reasonable levels of range safety. Ranges are not designed on the absolute worst case; design is to reduce risk to as low as reasonably practicable (ALARP). They are designed to capture all properly aimed projectiles with an additional degree of safety for acceptable aimer error and ricochet. Ranges are not designed to capture all projectiles from an unintended discharge. Ranges that were designed to type drawings have given no cause for concern and still meet the current minimum level of safety. Ranges which are new, refurbished and those having major repairs are to be constructed to the current design criteria in DSA 03. OME Part 3 Volume 2; advice and approval from RITT is to be sought. Legislative requirements of the Health and Safety at Work Act and the Management of Health and Safety Regulations are satisfied by the design process undertaken by consultants and contractors commissioned by the MOD under the conditions given in JSP 434⁴. The detail provided in this document addresses identified and predictable hazards, to which it provides engineering solutions to reduce the perceived risk to ALARP. The controls necessary to achieve these reduced risks are stipulated in Pamphlet 21, which in conjunction with DSA 03.OME Part 3 Volume 1 Part 2, form the major components of the Safe System of Work (SSW) whereby a safe environment for effective operational training with MOD ranges, is achieved.

2-53. **Accuracy Of Construction.** This publication provides the minimum standards that should be achieved. Where an element is fundamental to the level of safety provided it is indicated as critical criteria. These elements will be subjected to RITT review and approval during design and build, and compliance checks on completion of works. On existing ranges, elements that do not conform to the standard criteria are to be included in the range Risk Assessment to determine if the level of safety provided is affected. Where the level of safety is reduced, control measures must be applied to maintain the level of safety required. Where this cannot be achieved the range may only operate under waiver until such time as a full assessment is completed and ARS / MNC is authorised and / or remedial works complete.

2-54. **Compliant Ranges.** A compliant range is a range which meets the design and build criteria specified as Critical (C) for its type in DSA 03.OME Part 3 Volume 2. Where ranges have some degree of non-compliance RITT advice is to be sought to consider the range to be put forwards for Managed Non-Compliance (MNC), and a written audit trail is to be maintained. Such non-conformities may include construction tolerances, accuracy of measurement, and RITT endorsed variation of Standard dimensions. For any infrastructure non-compliance ARS is to be sought (see paragraph 2-10).

2-55. **Maintenance.** Effective maintenance is essential to ensure that a range conforms to current safety criteria. Range Wardens' duties are given in DSA 03.OME Part 3 Volume 1 Part 2. When a range does not warrant a full time Warden, the RAU is to appoint a competent person to carry out these duties. The frequency of inspections is given in DSA 03.OME Part 3 Volume 1 Part 2 and DIO Hard FM Inspections and Tasks and could be developed further in site specific handover documentation as part of the Board of Officers (BoO). Urgency of repair because of inspection is to be in accordance with categorisation criteria:

⁴ Joint Services Publication 850: Defence Construction in the Built Environment - Part 1

- a. Critical criteria. Range not to be used before works completed.
- b. Standard criteria. Works completed or assessed as MNC.

2-56. **Pre-Planned Preventative Maintenance.** Short notice maintenance works because of inspection mentioned above can be mitigated by RAUs making ranges available for pre-planned preventative maintenance.

2-57. **Conduct And Training.** A range is designed and built only for qualified, current, and competent personnel with weapon systems authorised for use on the range, under proper supervision and in accordance with appropriate instructions.

2-58. **Population Density.** Planning Staff and the BoO must consider the effect of population density and public sensitivity around a proposed range before determining location and orientation.

2-59. **Siting Preferences.** Outdoor ranges should ideally be sited facing north in the Northern Hemisphere and south in the Southern Hemisphere so that firers do not engage targets into direct sunlight. The range should also be sited as far as possible from habitation as it is difficult to reduce impulse noise generated without modification to the weapon. When siting ranges, aligning the direction of fire away from habitation, when possible, should take precedence. The total energy template should be considered when assessing population and habitation in the proposed new range.

Ballistic Performances of Weapons and Ammunition on Ranges

2-60. This section applies to SA; the limitations for other Inf WS are given in the appropriate Chapters.

2-61. **Weapon System Performance.** The performance of weapons can be expressed in several ways. For the design of ranges, Muzzle Velocity (MV) and Muzzle Energy (ME) are used. These performance criteria are derived from current MOD ammunition types in determining WDA, penetration data, backsplash, and ricochet. These criteria are used to control weapon systems which can be used on ranges. It is essential to specify the weapon performance limits for each range type to ensure that the range remains safe during use. Weapon performance may vary depending on several factors. Three of which are:

- a. **Type of Ammunition.** Certain types of ammunition can significantly enhance the effects of a weapon system that could result in its performance exceeding the design criteria of the range. Also, certain types of ammunition may have considerably different ricochet characteristics which may not be catered for in the standard design criteria.
- b. **Propellant.** In the case of hand loaded or re-loaded cartridges, the manufacturer's specification must be rigidly adhered to. Altering the quantity or quality of propellant to meet performance specifications can be dangerous. The MV and ME specifications for the range are not to be exceeded.
- c. **Different Variants of Weapon.** Weapons can have different variations which perform differently e.g. long barrels increase MV/ ME when compared against short barrels.

2-62. **Authorised Sa Weapons.** The requirement is to limit firing to those weapons that perform safely within the design criteria of the range. Only those weapons whose MV and ME do not exceed the criteria stated on the MOD Form 905 may be fired on constructed ranges. When only one performance criterion of a SA conforms to the authorised limits, RITT should be consulted on matters of construction and the DRSCWG for clearance to fire; both of which may wish to seek WESCO advice. For example, a light, small calibre bullet with an MV higher than the specification for the range may have an ME within the specification but such a bullet is likely to have very different ricochet characteristics to the slower, heavier bullet for which the range has been designed. Civilian long barrelled pistols may only be used with the shoulder stock extended. AP ammunition is not to be fired on constructed ranges unless the range has been specifically designed to accommodate such ammunition. For RDA details of authorised weapons refer to Chapter 15 Figs 15 - 2 and 15 - 3.

2-63. **Muzzle Velocity and Muzzle Energy Limitations.** For each range the limitations for SA, contained in Table 4 and any other limitations on how a range can be used will be stated on the MOD Form 905, in Range SO and on certificates issued to police or civil shooting clubs which may use the range. The commonly used term “Low Velocity” (LV) is related to serials 1 to 3 in Table 2-4, below. “High Velocity” (HV) refers to weapons with MV greater than 655m/s (2145ft/sec).

Table 2-4 - SA Ammunition Maximum MV and ME Limitations

(a) Ser	(b) Weapon Type	(c) Indoor MV (m/s)	(d) Indoor ME (J)	(e) Open MV (m/s)	(f) Open ME (J)
1	Air rifle	N/A	16 (12ft lbs)	N/A	16 (12ft lbs)
2	Rimfire weapon only	530 (1735ft/sec)	285 (210ft lbs)	610 (2000ft/sec)	480 (350ft lbs)
3	Centrefire pistol/carbine	520 ² (1705ft/sec)	645 ² (475ft/bls)	655 (2145ft/sec)	2030 (1495ft lbs)
4	Centrefire rifle NDA ranges	1000 (3280ft/sec)	7000 (5160ft lbs)	1000 (3280ft/sec)	7000 (5160ft lbs)
5	Centrefire rifle on ranges with GR LDA	Centrefire rifle on ranges with GR LDA	Centrefire rifle on ranges with GR LDA	1000 (3280ft/sec)	4500 ¹ (3319ft lbs)
6	Centrefire rifle on other ranges	Centrefire rifle on other ranges	Centrefire rifle on other ranges	No ME / MV limits - Refer to Chapter 15 Fig 15 - 2 to determine extent of RDA required.	No ME / MV limits - Refer to Chapter 15 Fig 15 - 2 to determine extent of RDA required.

Notes (Table 2-4):

1. Weapons with ME greater than 4500J but less than 7000J may be used on gallery type ranges providing authorised control measures are in place. Where there may be any doubt about the ammunition or practice, civil clubs and police are to be restricted to a maximum of 4500J, 1000m/s.
2. These Figs relate to defence structure specification in Table 7a.
3. Civilian use of tracer is not permitted on constructed ranges.
4. Civil clubs may only use copper or steel jacketed lead core or solid lead rounds on MOD ranges.
5. Range structures such as Control buildings or Effects Bunkers on the range floor and structures on IBSR have sufficient protection for weapons up to 7000J if they are correctly constructed and maintained.
6. Authorised control measures are those issued by HQ SASC for military snipers shooting standards are contained in OSP Vol 2 Sniper Shoots. Control measures approved by MOD and issued by the NRA for all civil and MOD police and all civilian full-bore target practice.

2-64. **Black Powder Weapons.** Black powder or black powder substitute propelled weapons may be fired on outdoor MOD ranges. The MV and ME is not to exceed the specified limits for that range. Black powder weapons are not to be fired in indoor MOD ranges.

2-65. **Combat Shotgun.** Combat shotgun is authorised for use on LFTTA or constructed ranges using buckshot or solid slug. WDA for combat shotgun is shown in Fig 15 - 2.

2-66. **Jacketed Bullets And Other Specified Ammunition.** Table 7a gives the required thickness of steel protective plating for indoor ranges to be safe against jacketed and unjacketed bullets. Tracer and other specified specialist ammunition may only be used when detailed in the range type chapters in this DCOP.

2-67. **Automatic Fire.** The constraints for automatic fire on specific ranges are set out in the relevant range type chapters. Additional limitations can be found in Pamphlet 21 & Joint Service Munitions Control Register (JMSCR).

2-68. **Tracer Ammunition.** For ballistic safety 5.56mm tracer ammunition can be treated as ball however other ammunition types cannot and advice is to be sought from RITT. Tracer may generate fires in granulate rubber and other material types. The RAU is to ensure that this hazard is considered for each range risk assessment and appropriate mitigation captured in Range SO.

2-69. **CQM LFMT Shoots.** When considering CQM LFMT shooting requirement it is essential to take into consideration potential excessive QE (e.g. when firing from kneeling position at 3m) and the additional LoF and associated CoF (e.g. multi-target multi-point of aim).

Range Details and Drawings

2-70. **Imperial And Metric.** In line with Government metrication policy implemented on 1 October 1975, all future range design will be in metric units. This document has converted imperial dimensions to metric, rounded as appropriate where safety parameters allow. Where ranges are converted from imperial to metric, then checks should be carried out using metric units.

2-71. **General.** The MOD, through the DRSC approves changes in design policy criteria and range standards outlined in this DSA 03.OME Part 3 Volume 2.

2-72. **Type Drawings / Standards.** Type Drawings were originally produced as a standard design for LFMT ranges; however, they became obsolete and were replaced with Type Standards. Type Standards, in turn have become out of date and are now no longer issued. Type Drawings and Type Standards are not to be used for the design nor construction of ranges but may be retained as historical records.

2-73. **Types Of Drawings.** There are four types of site-specific drawings for ranges described below. All these drawings are to be retained in the range file to maintain a complete and accurate audit trail. The first three types are drawings are those that are to be submitted to RITT for review and approval before being finalised.

a. **Design Drawings.** Design drawings are produced by a designer based on the information in this document. These drawings are produced as outline concept to inform Building Control submission and detailed design to inform the tender process up to award of contract. Further design drawings could be produced during construction.

b. **Construction Drawings.** Construction drawings are those produced during construction to aid the build and sometimes as a result discovering unforeseen ground conditions.

c. **As Built Drawings.** These are drawings (in some cases supported by photographs) that accurately record what was built. On some occasions this can be retitled design and construction drawings, but this is rare. These are collated and form a critical part of the BoO/ MOD Form 1057 audit trail.

d. **RITT Produced Drawings.**

(1) **Illustrative Sketches (IS).** Drawings are produced by RITT to aid users and designers in developing the concept during design and confirming what is built to assist and inform what is required to achieve compliance. It is highlighted that if there is to be any change of use or infrastructure works beyond repair the RAU / 2 LODA is to consider if this necessitates a new compliance check. IS drawings are also provided to illustrate an as built survey record of the dimensions of the range post RITT survey.

(2) **Licence Drawing (LD).** These RITT produced drawings are essential to the BoO/ MOD Form 1057 process. For each range the danger area is projected from actual lines of sight on that range, producing a range specific danger area template (for all ranges less NDA, TER, TERP, LFTTA or FTA). All open ranges should seek to have a LD that reflects their range danger area precisely and will also assist the siting of adjacent ranges or facilities. On range complexes where RDAs overlap adjacent ranges a table of restrictions is provided. Additional range management detail required by the RAU or DOSR may be included such as the range-controlled boundary. Where standard LFMT practices are conducted on TERP ranges, those standard LFMT practices should be captured on a LD.

2-74. **Range And Training Area Maps.** A critical part of safety is to ensure that all parties are using the most up to date mapping, particularly the danger area boundary lines.

To that end it is important to understand the authorised source of data / mapping, the types of maps, how coherence is achieved and how to update the data/ mapping.

Sources of Data / Mapping:

(1) **General Issue.** Defence Geographic Centre (DGC). DGC hold all data and mapping for general issue and are responsible for issuing large quantities of maps. Unfortunately Range and Training Area mapping updates are restricted to 8 maps each year and there is often a 'time lag' from necessary changes to DGC having the most recent data.

(2) **Local issue.** To provide timely and critical updates to maps local issue can be obtained from OS&DTE RITT Geo Mgr.

b. **Types of Maps** There are 2 types of range and training area maps:

(1) **Range Master Map.** Produced by DIO Geo Spatial Services (DEX). This includes standard information on MOD boundary, lease land, over firing rights, sea danger areas from the Hydrographic Office and the RITT supplied extent of range danger areas.

(2) **Training Area Mapping.** Produced by RITT. This includes critical safety information such as range danger areas, standard information (named ranges / range infrastructure, position of flags (or red lights if used in lieu) and signs and points of access) as well as the range Master Map standard information.

c. **Coherence and Ensuring use of Extant Data / Mapping.** It is critical that data / mapping issued is coherent and is following the criteria laid down in this document. For that reason, DIO Geo spatial services and RITT Geo Mgr are to keep each other informed of any changes / updates. RAUs and all end users of training area maps must ensure they are using the most extant version of the map. This can be done by checking with RITT Geo Mgr. RITT Geo Mgr will compare local data with DGC data and if same (or no safety critical differences) will inform users to access the DGC website, link below, and navigating to the correct country, area, series, and scale. End users are to source and provide all extant mapping. Maps can be ordered via the website for this purpose, if necessary, <https://jfig.ahe.r.mil.uk/catalogue/startup.htm>. If the data is different, then data / mapping for local use will need to be used.

d. **Updating of DGC Data/ Mapping.** RITT Geo is the lead for programming the 8 updates per year. A formal justification is required for a new training area map for general issue. A revision programme controlled by RITT is in place to update existing training area mapping. Training area mapping overlays provide additional information to assist troops training and the management of the training area by a RAU. RITT Geo will issue a notice of any changes in the DIO OS&DTE Monthly Update. Any discrepancies noticed on any map are to be notified to RITT at the address given below. All submissions for map revision or other taskings are to be directed to DIO OS&DTE RITT Geo Mgr via the contact details below and in line with: LINK

2-75. **SOI J3 Operations No:7 Training Area Mapping.** Submissions are to be accompanied by changes required either in written form, annotated on a current map or both. Danger Area Boundary changes are not to be promulgated to other internal or external agencies before being submitted to RITT Geo for ratification.

Contact details for Geo,
DIO OS&Trg Region RITT GEO
RITT
Building 25
Waterloo Lines
Imber Road
Warminster
Wilts BA12 0DJ

2-76. **Change Records.** Original critical and standard range ballistic construction details are recorded on the MOD Form 1057 Series. Any subsequent changes to the range shall be recorded onto the MOD Form 1057 Series. This is to ensure a clear audit trail is maintained and that all safety critical changes are checked by RITT for compliance.

Range Types

2-77. **Types Of Range by Danger Area Categories.** Examples of ranges which fall into the 4 categories by danger area:

a. **No Danger Area (NDA) Ranges.** To be classed as an NDA range, all anticipated shot and associated ricochet must be contained within the range with a substantial margin of safety. The following range types may be classed as NDA ranges:

- (1) Indoor Ranges including tube ranges.
- (2) 25m Barrack ranges.
- (3) The 1908 design 30 Yard range.
- (4) Some TERP ranges.
- (5) Non-standard open NDA ranges.

b. **LDA Ranges.** Ranges where some rounds are expected to leave the area of the range floor either from direct fire or ricochet, have a limited danger area to ensure all rounds are contained in a controlled area. Such ranges include:

- (1) **The Gallery Range.** The Gallery Range (GR) has a LDA based on the principle that the CoF is lifted from the range floor by the mantlet thereby reducing the incidence of ground ricochet, the primary source of rounds escaping a range. A 1830m RDA is applied from the target line. Most existing GR ranges have a QE restriction (QEmax) of 70mils, which equates to QEtch of 30mils to ensure the LDA is sufficient. GR with modified mantlet and stop butts that have been increased in height to capture the whole CoF do not need to impose the QE restriction as all predicted direct fire from the 100m firing point will be captured. A further reduction in the length of the RDA from 1830m may be considered when hill background criteria is met or WDALab indicates that a smaller RDA will provide a similar level of safety.
- (2) **The Converted Gallery Range.** This range is a GR with the gallery frames and Fixed Electric Targets (FETs) mounted into the top of the mantlet.

(3) **The Electric Target (Limited Danger Area) Range (ET(LDA)R).** This range has no gallery, has Fixed Electric Targets (FETs) mounted into the top of the mantlet.

(4) **The Grouping & Zeroing Range.** 100m range constructed to gallery criteria with a full stop butt.

(5) **Baffle Ranges.** Open baffle ranges are no longer considered cost effective designs as they do not, as previously thought, capture all rounds. UK Baffle ranges are designated as Approved Ranges following WESCO advice. German Baffle ranges operate with Cautionary Zones as described in German Standard Range Specifications.

(6) **1908 Style Barrack Range and Centrefire Non-Standard No Danger Area ranges with no canopy.** Ranges with normal bullet catcher but without a canopy are classed as LDA ranges as they have a 100m RDA beyond the back wall and to the flanks to take account of expected ricochet. Where the bullet trap face is 56° or more no ricochet is expected.

(7) **Hill Background Ranges.** Open ranges with a hill rising behind the stop butt may be assessed by WDALab to determine the actual RDA required on such ranges.

c. **Full Danger Area (FDA) Ranges.**

(1) The 100m Grouping & Zeroing range. Where gallery criteria is not met this range operates on a WDA. A small stop butt may be provided to indicate the fall of shot.

(2) **The Electric Target Range.** A flat range floor with FETs located at 100m, 200m & 300m from the main firing point. All shot is automatically recorded, and targets can fall when hit. A WDA is applied with hard target wings when necessary.

(3) **Mechanised Moving Target Trainer Range.** A flat floor range with 10m target runs for each lane. A WDA is applied.

(4) **Individual Battle Shooting Range.** This range provides excellent Transition to Live Firing Tactical Training (TLFTT) providing firing from cover, controlled LFTT and moving targets. A WDA is applied with hard target wings when necessary.

(5) **Pistol Ranges.** When fired on LDA / FDA ranges the pistol template is applied in accordance with the principles illustrated in Fig. 15 - 2 using the CoF for pistol under LDA / FDA ranges in Table 3. A 1500m RDA is usually applied.

(6) **Live Firing Tactical Training Areas (LFTTA).** Used for tactical training using a QE<150 mils. A WDA is applied with hard target wings when necessary.

d. **Total Energy Area (TEA) Ranges.**

- (1) Moving Vehicle.
- (2) Some LFTTA activities, such as AD.

Range Design

2-78. **Ranges Grouped by Danger Area.** Key constraint on range design is the availability of danger area. Where there is an abundance of space then the requirement for infrastructure is reduced, along with the associated build and maintenance costs. Where there is a limited danger area or no danger area then there is greater requirement for infrastructure with associated extra cost. There are four categories into which all ranges fall to provide a safe shooting environment.

- a. **Total Energy Range.** A Total Energy Range has no constraint on elevation and will have a template large enough to capture all shot fired in a particular direction without further restriction. Large land or sea danger areas are required to capture the maximum projectile trajectory.
- b. **Full Danger Area Range.** A Full Danger Area (FDA) range is an open range where the hazard is limited by the elevation of the delivery system and the skill of the firer. The amount of land or sea danger area required is minimised by controlling the elevation of the weapon.
- c. **Limited Danger Area Range.** A Limited Danger Area (LDA) range is an open range for which the minimum design requirements are to capture direct shot and any resultant ricochet remains within the RDA. A combination of limiting elevation and the inclusion of range structures to capture shot and / or minimise ricochet, enables the danger area to be further reduced.
- d. **No Danger Area Range.** A No Danger Area (NDA) range is a range where the design precludes risk of injury or damage to persons or property outside the range. A combination of limiting elevation and the inclusion of range structures to capture shot and / or eliminate ricochet, enables use without a danger area.

2-79. **Safe Design.** The standard details provided in the respective range chapters have proven to be safe over a long period of extended use. The standard design incorporates a large factor of safety from both existing range criteria and CoF. Any deviation from Standard design is to be as safe as a standard design and approved by RITT. Changes can be made to Standard or Typical criteria but not Critical criteria to ease maintenance and therefore become more cost effective in use. Factors considered to ensure a safe range include:

- a. **Direct Fire.** For design purposes, direct fire is that shot which falls within the Cones of Fire (CoF) set out in Table 3. Experience, trial evidence and advice indicate that these CoF are more than adequate for authorised practices. Predicted direct fire is either stopped by defence structures, limited by QE (see Fig. 2 - 6) or an FE template is provided.
- b. **Ricochet.** Ricochet is defined in paragraph 2-41. Ricochet from range structures and surfaces have an impact on range design. Ricochet must be expected off all surfaces that a round may strike at angles of less than 30° including standing

water. Ricochet is minimised off slopes of 30° or more and eliminated off slopes of 56° or more. Ricochet will influence the size, material and shape of defence structures and danger areas including the air danger height. The use of ricochet pits can reduce the height of capture structures. On all ranges, rounds that strike the range may:

- (1) Be captured by the ground or structure.
- (2) Break up on impact and fragment over a small area.
- (3) Remain intact, change direction, exit at shallow angle and tumble with sufficient residual energy to achieve medium range potential.
- (4) Remain intact, change direction, exit at shallow angle, re stabilise, with sufficient residual energy to achieve longer range potential.
- (5) Remain intact, change direction, exit at steep angle, with sufficient residual energy to achieve 'pop over'.
- (6) Deflect off target frames or other range components with little loss of energy.

c. **Backsplash.** Backsplash is defined at paragraph 2-12. Provision must be made to prevent backsplash from any structure, fixtures or fittings that may result in the projectile returning to the firing point. Table 2-2 gives backsplash distances and the relevant range type chapters give further details. There is an additional hazard from poorly designed or fitted protective measures. If a round can pass through a timber baffle, protective material, target backing, target holder or post, it may decelerate sufficiently so that it does not penetrate through the anti-splash curtain but bounces back from the curtain and could reach the firing point with a hazardous velocity. This problem may occur on indoor; tube, TERP or other ranges where anti-splash curtains are used.

d. **Hidden Attrition.** High velocity rounds penetrate soft material, such as timber, losing very little energy and leaving only a slight indentation at the point of entry. When a round strikes the dense material behind, all the energy is dissipated, often causing extensive damage (attrition) behind, the softer protective material. Defence structures should be capable of taking all the predicted shot over a long period without undue attrition and should be designed to eliminate the possibility of hidden attrition. Where this is not possible procedures will need to be put in place to ensure the ballistic element is not penetrated. This will entail ease of access to facilitate inspection of the hidden element.

e. **Fixings.** When fixing a material to the structure in the ballistic zones, care is required to ensure unwanted ricochet or backsplash is not caused. Oval or lost head nails not round head nails, are to be used to fix timber on to hard surfaces and the nail heads punched in. Bolts and screws are to be countersunk and plugged. Any other metal fixings are to be protected. The wider heads of round head nails will cause rounds to shatter on impact sending fragments of nail head and bullet in many directions. Industrial staples may also be used to fix targets to timber supports. All exposed fixings need to be made of a soft material i.e aluminium, copper brass or nylon.

f. **Ballistic Rubber Tiles.** Ballistic rubber tiles may be used either as part of a bullet catcher system or to face structures, or parts of structures, so that backslash and ricochet is either eliminated or significantly reduced. It is to be noted that the tiles are intended to provide backslash protection only and it is anticipated that rounds will pass completely through them. The rubber tiles may offer some acoustic benefits, reducing reflection and reverberation, however this is not their primary purpose. Tiles should either not harbour lead and unburned propellant or be easily cleaned so that lead and unburned propellant do not build up within the tile.

(1) When used as part of a bullet catcher system the supplier is to ensure that the system will be suitable for the use to which is intended, particularly regarding the volume of shot that is to be expected and the ammunition type specified. When engaged perpendicular to the bullet catcher face, rounds are to be contained without backslash within the bullet catcher system. A method of monitoring hidden attrition is to be provided.

(2) When used to clad structures or provide protection against backslash, the supplier is to ensure that the tiles will be suitable for the use to which is intended, particularly regarding the volume of shot that is to be expected and the ammunition type specified. The tiles should be mounted with a 25mm (minimum) offset from the face of the structure to allow an airgap in which rounds can break up after striking the structure and not build up within the tile. When engaged perpendicular to the bullet catcher face backslash should be contained by the tile. A method of monitoring hidden attrition is to be provided.

2-80. **Design Criteria.** Common to all range design are the following criteria:

a. **Line of Fire (LoF).** An imaginary line taken from the barrel of a weapon to the point of aim on a target. Range structures in front of the barrel and down range such as baffles are designed by applying the respective CoF to the LoF or Lines of Fire where more than one points of aim or firing points exist.

b. **Line of Sight (LoS).** The LoS is the line from the weapon sight to the point of aim on a target. Clear vision parameters are applied to the LoS. Structures or objects close to the firer may not block the LoS might be directly in the LoF. Structures at the target end of the range are designed by applying the CoF to the LoS.

c. **Firing Postures.** Design of ranges needs to take account of the authorised shooting postures. In considering postures it is acknowledged that supported firing positions provide a more stable weapon platform, and this could be used as a restriction on non-standard ranges. Supported practices allow smaller CoF to be used (see Table 1-3).

d. **Posture Heights.** The following posture heights are used as design criteria. There will inevitably be some variation due to individual physical characteristics, however as these are not predictable.

- (1) Standing unsupported - 1500mm (C).
- (2) Kneeling / sitting / squatting - 800mm (C).
- (3) Prone / supine / standing in a fire trench - 300mm (C).

- (4) Light vehicle - 1200mm (S).
- (5) Heavy vehicle - seek RITT advice.
- (6) Lying pistol – 150mm (C).

e. **Clear Vision Line (CVL)**⁵. Although primarily used in the development of indoor shooting facilities it is also a good principle to apply to outdoor ranges. A CVL is projected from each firing posture to avoid distractions directly in front of the firer and to help minimise the risk of backsplash from protruding structures down range. The CVL should extend:

- (1) **Vertically**. The upper line is projected from 600mm above the highest firing posture used on the range to 250mm above the highest target centre. The lower line is projected 300mm below the lowest posture height used on the range to 250mm below the lowest target centre (see Fig 3 - 3).
- (2) **Horizontally**. The flank CVL is 500mm parallel to both flank LoF at all firing points down the complete length of the range.

f. **Trajectory**. At longer ranges the trajectory of a bullet needs to be considered as it does not follow the LoF in elevation. Trajectory is to be used to determine the height and position of down range structures to minimise attrition.

2-81. **Range Components**. Component details provided in this document ensure the required level of safety is provided irrespective of location. See details in respective range chapters. Common to most ranges are:

a. **Firing Point**. Firing points can be at varying distances and heights provided the appropriate lines of fire are used to establish requirements for protective structures. Each firing point should be accurately positioned and marked on the ground to establish and maintain correct lines of fire and determine if protective structures are required. Distance markers are to be provided on both flanks. Where there are elevated firing points it is essential to ensure that the elevated LoF does not expose mechanised target systems to direct strike. The standard firing point for outdoor ranges is shown at Fig 2 - 16. The key points of the standard firing point are that:

- (1) The minimum firing spacing is to be maintained.
- (2) The front crest is 450mm (S) above the range floor, though see range chapters for variations. For firing points constructed from earth or other soft materials a front crest board is to be installed to clearly mark the crest. A rear crest board may be installed to aid maintaining the profile. Crest heights significantly greater than 450mm may require consideration of access and egress, also falls from height may need to be considered under the site-specific risk assessment.
- (3) The fall from the front and rear crests is 1:6 (9.46° (T)). Where steeper than 1:6 consideration is to be made for possible slips, trips and falls. Shallower slopes may also be allowable on some ranges, see individual chapters.

⁵ The CVL does not apply when the barrel is clamped or specifically positioned within an aperture e.g. in a TERP or tube range

- (4) The 1:12 (4.76°) fall on the top of the firing point is Typical but should not be either excessively steeper or sloping in the other direction (i.e. from rear to front).
- (5) The length between the front and rear crests is to be sufficient for a person to lay in the prone position. The length given in Fig 2 - 16 is Typical, but it is not to be reduced to such an extent that the prone position cannot be adopted unless that position is specifically excluded from the permitted practices on the range.
- (6) Lane markers, on all firing points, are to be clear and consistently located across all lanes (i.e. all central or all to one flank). The preferred position is centrally within lane.
- (7) Firing posts and trenches should be installed where practical to do so but they are not mandatory requirements.

(a) **Firing posts.** These are typically 100mm x 100mm, and are 1200mm (S) high, measured from the top of the firing point crest. The depth below ground will need to be determined to suit the site-specific fixing method but the post is to be suitably held in place so that it offers support and does not move excessively when leant upon.

(b) **Trenches.** Where fitted, these are typically 1200mm x 750mm x 1100mm. Note: Older trenches may be 600mm wide as this was the standard size of the concrete box drainage section used in their construction. The front of the trench should be a minimum of 450mm (S) back from the firing point crest. Trenches are to be properly drained. Where concrete box sections or other hard materials are used to form the trench a timber surround is to be fitted on top of the hard material to prevent hard surface ricochet or backsplash. This timber surround is typically 225mm deep, at the front edge, but must be sufficiently deep enough to ensure that the hard material cannot be struck from any firing point further back; the topology of the range will determine the actual minimum requirement. Note: if the firing point is the rearmost one no timber surround is required. The finished floor level should be 1100mm below the front of the trench, typically a 1200mm deep trench is used with 100mm of 10mm single sized gravel (pea gravel) in the bottom. The hardcore base, typically 150mm, is to be suitable and sufficient for the ground conditions to ensure that the trench does not sink or otherwise move.

(8) **Construction Materials.** Whilst the materials shown are indicative, other materials must be suitable for the type and location of the firing point. Any firing point with further firing points to the rear is not to have any hard material exposed to strike which may cause a hard surface ricochet or backsplash. Firing points commonly occupied by firers should have a surfacing of 10mm graded granite chippings or equal to a depth of 75-100mm set into the firing point. Surface coverings, such as poured rubber, may aid maintenance but coverings such as timber may present a slip hazard when wet.

- b. **Tactical Barricades.** The following rules apply to the use of Tactical Shooting Barricades during LFMT on Purpose-built Ranges (see figure 2-17).

(1) **LDA Ranges.** Barricades are NOT PERMITTED for use on Gallery or Converted Gallery Ranges.

(2) **FDA Ranges:**

(a) Appropriate security (i.e., filled sandbags, ground strops, pegs, etc.) is required to ensure the Barricade does not blow over during inclement weather. Where the wind is so strong that it causes excessive movement, the Barricade should not be used.

(b) Tactical Shooting Barricades are to be positioned within lane, at the front crest, so that the approved line of fire from the barrel to the target is achieved.

(3) **NDA Ranges:**

(a) The use of Tactical Shooting Barricades is only permitted at the 25m firing point when using centrefire rifle.

(b) For Pistol practices only firing closer than 25m, lower than the kneeling position that result in a muzzle height of less than 800mm from the ground **are not to be used** (i.e. Prone, Low Sitting, Low Squatting).

(c) Appropriate security (i.e., filled sandbags, ground strops, pegs, etc.) is required to ensure the Barricade does not blow over during inclement weather. Where the wind is so strong that it causes excessive movement, the Barricade should not be used.

(d) Tactical Shooting Barricades are to be positioned within lane, at the front crest, so that the approved line of fire from the barrel to the target is achieved.

(e) For Pistol practices only firing closer than 25m, the barricades are to be positioned centrally within lane.

c. **Firing Point Spacing and Lane Widths.** To establish sufficient space for the firer taking account of distraction, ejected cases, smoke and noise, the following minimum distances from firer to firer are critical. There is no maximum spacing though excessively wide firing points should be avoided. Standard details are provided in respective range chapters.

(1) Rimfire rifle (single shot bolt action) - 1000mm (C).

(2) Rimfire & centrefire pistol / carbine semi-automatic - 1000mm (C) with benches & screens, 1800mm (C) without screens.

(3) Centrefire rifle - 1800mm Single Shot (SS) (C), 2500mm Automatic (C).

d. **Backsplash and Ricochet Protection.** On all ranges exposed hard surfaces, services and the like must be protected from direct fire to prevent backsplash and ricochet. Traditionally timber is added to the face of hard surfaces and steel baffles to prevent backsplash and excessive ricochet, but other materials may be just as suitable. The material used must prevent the bullet back-splashing or ricocheting back out from the protection. To reduce attrition, the protection material is offset from

the hard surface to allow the bullet to break up on the hard surface without causing excessive damage to the protection material. Where softwood timber is used the following will be deemed compliant⁶.

(1) **Rimfire.**

- (a) Outside the backsplash zone; 25mm boarding on 25mm battens (C).
- (b) Within the 10m backsplash zone; 50mm boarding on 25mm battens (C).

(2) **Centrefire.**

- (a) Outside the backsplash zone; 50mm boarding on 50mm battens (C).
- (b) Within the 22m backsplash zone; 75mm boarding on 50mm battens.

e. **Target Positioning.** Target positioning is critical to ensure rounds are kept within the RDA, and to give full target exposure for correct practice and to prevent infrastructure attrition. When targets are fixed as part of the design it is to be checked and approved by RITT. When targets are not fixed the design target centre height and flank target positions should be permanently marked. Such marking ensures the correct relationship with defence structures is maintained. Positioning of targets in accordance with the following guidelines should assist in providing sensible parameters for target positioning and enable realistic lines of fire whilst not compromising the safety of the range.

(1) **Target Heights.** The target centre should typically (T) correspond to the height of the weapon to achieve a near level line of fire, although there are circumstances which may demand either elevated or depressed lines of fire. Typical target centre heights of between 450mm (T) lowest and 1500mm (T) highest are recommended. Standard details are provided in subsequent chapters.

(2) **Target Spacing.** The target centre spacing should typically correspond to the spacing of the firers although converging lines of fire are acceptable. With converging lines of fire, targets are not to be spaced so closely together that they overlap and should be spaced so that each target is identifiable from the adjacent target when viewed from the firing point(s). Typically, the maximum spacing is parallel to the firer spacing (diverging lines of fire are not normally used as this would increase the size and cost of protective structures and danger areas).

(3) **Multi Point Targets & Target Screens (less CQM).** Where such targets are used the minimum defence structure dimensions provided in Table 2-6 are applied from the centre of the target for those authorised targets illustrated in Chapter 24 and from the highest or flank point of aim as illustrated in Fig 2 - 5 for other multi point targets. Once established the maximum target centre height and flank target positions should be clearly marked.

(4) **Multi Point Targets for CQM.** Multi point targets can be used for CQM, but they have a critical impact on RDA, range infrastructure attrition, backsplash

⁶ The use of oval nails in fixing such boarding will minimise potential backsplash hazards.

and ricochet. Any such requirement is to have been reviewed and approved by RITT. For CQM targetry the upper aiming point does not need to be marked.

(5) **Target Positional Markings.** Maximum and Minimum Target Centre Height. The highest and lowest permitted target centre height should be indicated at the target line on both flanks (a recommended method of marking can be seen below Fig 2 - 3). These markings should be in a highly contrasting colour paint and permanent.

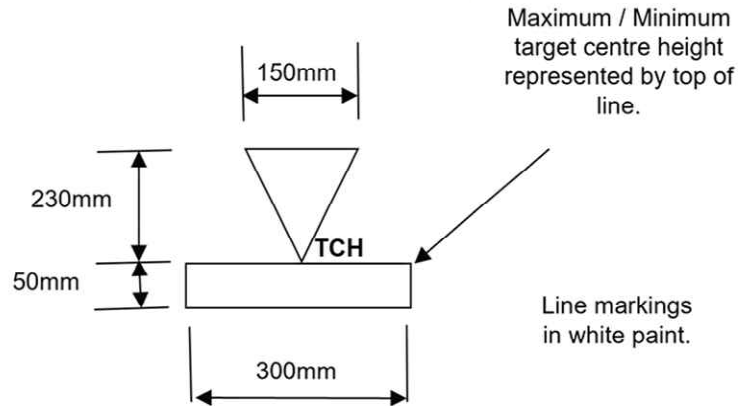

Fig 2 - 3. Typical Target Centre Height markings.

(6) **Flank Target Markings.** These should be clearly indicated at the target line, for both left and right flank most targets. These markings should be in a contrasting colour paint and permanent. No target should be positioned outside of these marks. The flank target markings should be marked, either on the floor or the mini mantlet, but in front of the target line. The markings should be easily visible to all range users, a typical method of marking can be seen in Fig 2 - 4.

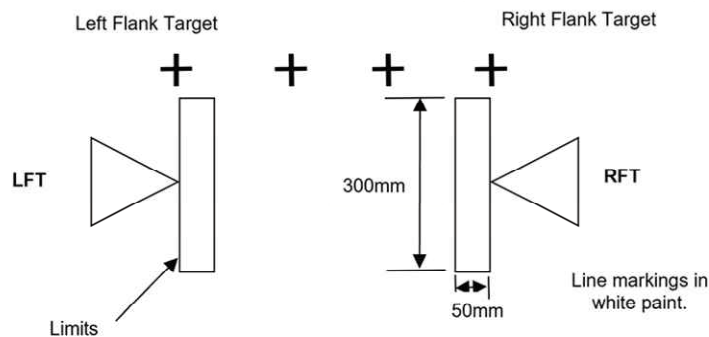

Fig 2 - 4. Typical Flank Target Markings

(7) **Multi Point Targets & Target Screens.** The Target Centre Height left, and right extent markings are critical and therefore are to be applied to the highest, left and right flank most aiming points as shown in Fig 2 - 5.

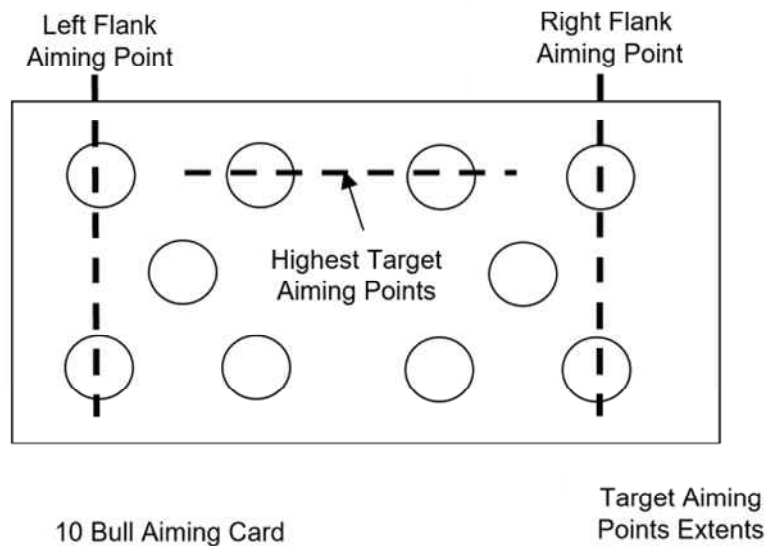

Fig 2 - 5. TCH Multi Point Targets & Target Screens

(8) **Range Floor Markings.** As a standard all lanes are to have number markings, typically in the centre of each fixed firing point. At close range (50 metres and less to the target) it is critical to mark lane FPs to ensure rounds stay within the RDA. For specific range markings refer to the respective range chapter.

(9) **Bullet Catcher / Bullet Trap.** The bullet catcher or trap is designed to capture most rounds fired at each target. Bullet catchers are normally sand / earth bank / rubber granulate or steel plate design. Bullet traps are normally those of proprietary design, such as the Snail Trap or rubber granulate trap. For economic, logistical, and environmental reasons, indoor bullet traps are often constructed with a combination of a bullet catcher and an area of protection to capture wide shot. Granulated rubber traps provide cost effective and environmentally friendly trap solutions as rounds do not tend to break up causing lead dust. This form of trap is suitable for indoor or outdoor use. It will be seen that the use of a bullet trap and backplate indoors provides the same dimensions overall as bullet catchers used on outdoor ranges. The dimensions of the bullet catcher / trap components for standard ranges are provided in the respective range chapters. Where details are not provided the details in Table 6 may be used.

(10) **Stop Butts.** Stop butts are located around or behind bullet catchers to capture wide shot and low ricochet. Where stop butts are provided the criteria to determine height and width are contained in the respective chapters. For Non-Standard NDA ranges the minimum criteria is provided in Tables 2-5a and 2-5b.

Table 2-5a - Defence Structure Dimensions – Indoor⁷ Ranges

(a) Ser	(b) Range Component	(c) Axis Measure from the LoS	(d) Height and width Rimfire Rifle	(e) Height and width Rimfire Pistol	(f) Height and width Centrefire Pistol	(g) Height and width Centrefire Rifle
1.1	Defence zone	Vertical (mils)	125	200	215	215
1.2	Defence zone	Horizontal (mils)	75	125	215	215
2.1	Backplate	Vertical (mils + mm)	3 + 700	6 + 850]	6 + 1500	
2.2	Backplate	Horizontal (mils + mm)	3 + 450	6 + 600	6 + 1400	
3.1	Bullet Catcher Indoor	Vertical (mils + mm)	3 + 250 3 + 250	6 + 400 6 + 300	6 + 450 6 + 450	1 + 1700 3 + 1400
3.2	Bullet Catcher Indoor	Horizontal (mils + mm)	3 + 250	6 + 300	6 + 450	3 + 1400

Table 2-5b - Defence Structure Dimensions – Outdoor Ranges

(a) Ser	(b) Range Component	(c) Axis Measure from the LoS	(d) Height and width Rimfire Rifle	(e) Height and width Rimfire Pistol	(f) Height and width Centrefire Pistol	(g) Height and width Centrefire Rifle
1.1	Bullet Catcher Outdoor	Vertical (mils + mm)	3 + 700	6 + 850	6 + 1500	1 + 1700
1.2	Bullet Catcher Outdoor	Horizontal (mils + mm)	3 + 450	6 + 600	6 + 1400	3 + 1400
2.1	Stop Butt Criteria	Vertical (mils + mm)	20 + 2500 30 + 1000	60 + 3500 60 + 2000	60 + 4000 60 + 4300	77 + 4700 60 + 4000
2.2	Stop Butt Criteria	Horizontal (mils + mm)	30 + 1000	60 + 2000	60 + 4300	60 + 4000

⁷ Including Tube Ranges where the bullet catcher is not designed to capture all shot and ricochet.

2-82. **Range Materials.** Many materials have been tested for resistance to bullet penetration providing some evidence that may be used in the design of defensive structures. Below are performance details of the ballistic materials known to date.

a. **Steel Specifications.** Where proprietary systems are not provided, the requirement is for the following British Standard (BS), MOD DEF STAN specification, or similar performance steel:

(1) Mild Steel - BS EN 10025: S275JR.

(2) Armoured Steel - DEF STAN 95-13. AR 500 or similar has proven effective where high velocity ammunition is used. Through hardened armoured steel is normally used in areas of direct bullet impact. Trials have shown that 5.56 mm may penetrate armoured steel when extreme close grouping is achieved and with impact velocities more than 920m/s.

Table 2-6a - Steel Protective Plating for Ranges

(a) Ser	(b) Ammunition	(c)	(d)	(e)	(f)	(g)
		Defence zone plate thickness (mm) (c) Flank	Defence zone plate thickness (mm) (c) Direct	Backplate plate thickness (mm) (c) Flank	Backplate plate thickness (mm) (c) Direct	Bullet catcher plate thickness (mm) (c)
1	Rimfire	3	4	4	5	6 or 4 armoured
2	Centrefire pistol/carbine	4	5	5	6	8 or 6 armoured
3	Centrefire pistol/carbine jacketed	5	6	6	8	12 or 8 armoured
4	Centrefire rifle	12 or 8 armoured	12 or 8 armoured	proprietary system only	proprietary system only	proprietary system only

b. **Other Material.** Table 2-6b provides minimum depth of the material required to prevent penetration on ranges dependent upon angle of strike. Minimum material specification for concrete is 20N.mm², Solid (void free) Class B engineering brick, 15N.mm² dense concrete block or hollow block filled with min 15N.mm² concrete. Concrete, brick, and block defence structures shall prevent bullets penetrating more than 10% into the surface of the structure.

Table 2-6b - Minimum Thickness (in mm) of Construction Materials Considered to be Impenetrable to Bullet Strike**At all Angles Multiple Strike**

(a) Ser	(b) Ammunition	(c) Concrete (C)	(d) Solid Brick (C)	(e) Concrete Block (C)	(f) Timber (C)	(g) Remarks
1	Rimfire	75	100	100	125h/w or 150 s/w	
2	Centrefire pistol carbine	150	215	215	175h/w or 200s/w	Monitor effect of 4.6mm steel ammunition on all structures.
3	Centrefire rifle	200	215	215	250h/w or 375s/w	No AP ammunition permitted.

Defence Zone - Single shot at 90° (1600 mils) to surface or less. (C)

(a) Ser	(b) Ammunition	(c) Concrete (C)	(d) Solid Brick (C)	(e) Concrete Block (C)	(f) Timber (C)	(g) Remarks
1	.22"	25 ¹	75 ¹	50 ¹	125s/w	See Note 1 & 2

Defence Zone - Single shot at 7° (124 mils) to surface or less. (C)

(a) Ser	(b) Ammunition	(c) Concrete (C)	(d) Solid Brick (C)	(e) Concrete Block (C)	(f) Timber (C)	(g) Remarks
1	.22"	25 ¹	75 ¹	50 ¹	20s/w	See Note 1 & 3

Notes (Table 2-6b):

1. These dimensions have been rounded up to reflect sizes available.
2. Or combinations of MDF 25mm + Redland plain tile, Plywood 25mm + Redland plain tile, 50mm s/w + Glasuron terracotta tile should contain one .22" round.
3. Alternate Material Indoor Range Defence Zone only - 0.22" ammo - Roof or wall material which includes: Redland plain tile, Natural slate, Double roll tile, Glasuron Terracotta tile, Plasterboard 12.5mm, T&G board 12mm, Plywood 12mm, Chipboard 12mm, MDF 12mm, Strandboard 18mm. Condition of materials may be variable: this table reflects material in perfect condition.

- c. **Maintenance.** Where range structures are maintained within the ballistic envelope, they must be maintained to retain the original properties. The maximum depth of attrition that should be permitted before repairs are affected is 10%. Back walls above the sand for instance are generally at least 225mm thick. Attrition up to 22mm should not adversely affect the performance of that component. Repairs to anti splash curtains could cause back-splash if more than two layers are in the line of fire, i.e. repairs where sheet overlap occurs. If in doubt refer to the RITT for advice.
- d. **Environmental Hazards and Sustainability.** Range design must take account several factors, including but not limited to, the effect of lead, carbon monoxide, unburnt propellant, and noise. Below in Table 8 are indications of the design issues to be addressed, which typically controls most other known factors. Note, where ranges fire less than 1 million rounds per year DGM PT predict no unacceptable environmental or health hazard impact from SA ammunition. Ranges that have rates of fire more than this should be assessed for environmental or health hazards. For ranges with enclosed or semi-enclosed firing points refer to Chapter 25.

Table 2-7 - Environmental Hazards and Sustainability

Range Types	Lead	Carbon monoxide	Unburnt propellant	Noise
LFTTA, ETR, MMTR, IBSR	Maintain MOD Form 906 record of rounds fired on each range for future Land Quality Assessment.	No issue	No issue	Note 1 & 2
GR all types	Majority of lead is removed periodically from the range.	No issue	No issue	Note 1, 2 & 4
Barrack ranges	All lead is removed periodically from the range.	No issue	No issue	Note 1, 2 & 5
Tube ranges with enclosed firing room.	Lead will be present in any dust. All lead is contained and recovered during deep clean.	With mechanical ventilation no issue. Without ventilation CO monitor required.	In any dust	Note 1
Other ranges with enclosed or semi enclosed firing points.	Lead will be present in any dust. Maintain MOD Form 906 record of rounds fired on each range for future Land Quality Assessment.	With mechanical or sufficient natural ventilation no issue. With insufficient ventilation CO monitor required.	In any dust	Note 1, 3 & 5
Indoor ranges	Lead will be present in any dust. All lead is contained and recovered during deep clean.	With mechanical ventilation no issue. Without ventilation CO monitor required.	In any dust	Note 1, 3 & 5
Sand Stop Butts & Bullet Catchers	Lead in sand butts is generally stable in terms of leaching. Where steel ammunition is fired into a butt that has lead rounds in it, there is a possibility of the lead leaching caused by the rusting of the steel ammunition in contact with it.			

Notes (Table 2-7):

1. Appropriate hearing protection is to be worn on all firing points during practices.
2. The siting board is to ensure new ranges are sited as far away from populated areas, offices, or other sensitive buildings as possible. MOD freehold land around ranges extending for 300m (Nugent ruling) should be retained to preserve this separation from potential development.
3. For indoor ranges and non-standard ranges with enclosed or semi enclosed firing points refer to Chapter 25.
4. Where 7.62mm is fired regularly (more than 50,000 rounds per lane per year) on a range into sand or earth stop butts the RAU should commission an analysis of the MPI to determine levels of antimony against current EU limits.
5. Where close engagement (15m or less) takes place on ranges with granulated rubber RAU should be aware that if the granulate is exposed it could absorb unburnt propellant that will increase the risk of fire.

2-83. **Noise.** It is MOD policy that all those exposed to weapon noise must wear appropriate hearing protection. There is a requirement to reduce noise levels further by applying additional control measures. Such control measures generally take the following two forms:

- a. **Noise Containment.** The building fabric, doors, ducting etc, are designed to reduce transmitting noise to the outside environment and to the surrounding structure. Dense materials should be selected for the building fabric of the firing points and bullet catcher chambers. Doors, ducts, and other openings can be specified to give a similar level of noise insulation. See also Chapter 26.
- b. **Noise Attenuation.** The nature and treatment of internal surfaces are selected to attenuate reflected noise (reverberation) but these measures will not reduce the initial high level of noise produced by the weapon. There are many materials available, such as wood, wool slab, rockwool and glass fibre, which are very effective in reducing reflected noise. However, these materials will also harbour lead dust and unburnt propellant and are difficult or impossible to clean as the fibrous materials are susceptible to damage. Whilst these materials may be suitable for ceilings, walls should be clad with a material which withstands knocks and abrasion, and which can be appropriately cleaned. Granulated rubber tiles and tiles of resin bound flint sand have been found effective. Proper selection and detailing of the noise attenuation system will further enhance noise containment. Care is required for tube ranges. See also Chapter 26.

2-84. **Lead Pollution, Unburnt Propellant and Carbon Monoxide.** The requirements to control lead pollution, unburnt propellant and carbon monoxide in ranges are given in Chapter 25. The provisions of JSP 375⁸ apply to ranges that do not meet the criteria in Chapter 25.

2-85. **Hill Backgrounds.** Hill background for GR, CGR and ET(LDA)R criteria are illustrated in Fig 2 - 10 but are exceedingly rare. Before a reduced RDA is authorised for use, the following must be confirmed by RITT and / or the issue assessed by WESCO prior to seeking ARS through DRSCWG:

⁸ JSP 375 Management of Health and Safety in Defence

2-86. **For Hills Or Cliffs (>56°) Directly Behind The Target Line.** The hill has a minimum mean slope of 56° (996mils rounded to 1000mils) rising immediately behind the target line and has a minimum height of 50m above the point at which the LoS from the 100m firing point meets the perpendicular from the summit. When such a slope spans the full width of the RDA trace, the reduced probability of escapement enables the length of the trace to be reduced to the 50m point.

- a. **For Hills or Slopes (>30°) behind the Target Line.** Alternatively, the hill has a minimum mean slope of 30° (533mils rounded to 530mils) rising behind the stop butt and has a minimum height of 100m above the point at which the LoS from the 100m firing point meets the perpendicular from the summit. When such a slope spans the full width of the RDA trace, the reduced probability of escapement enables the length of the trace to be reduced to the 100m point described.

Sand Bullet Catchers

2-87. **General.** Typically, sand has been used in bullet catchers and stop butts on many of the ranges described in DSA 03.OME Part 3 Volume 2. This section specifies the quality of the sand, its profile and maintenance that are necessary to capture shot without causing ricochet or back-splash. Wet sand will have the tendency to form tunnelling on ranges where tight grouping is expected which may result in penetration of the bullet catcher.

2-88. **Quality.** Sand should be formed of crushed stone, with angular shape to assist slope stability. Granite or Quartz generally have the physical properties to resist natural breakdown. Over time the sand will reduce to fine dust, especially behind the MPI, due to the impact of rounds. When the sand reaches this point, it will require replacement. River or sea washed sand is not to be used as the grains tend to be rounded and thus lack good mechanical interlock.

2-89. Sand type should conform to BS EN 12620:2002 description "0/4 Concrete Sand." Grading of sand should conform to BSI PD 6682-1 Table D1, "0/4 Concrete Sand CP" (Coarse Product). This grade is fine enough not to cause ricochet should be coarse enough to retain the required profile effectively without likelihood of setting or forming a surface crust. It is also relatively stable in high winds.

2-90. Some basic testing of samples may be required to assess its suitability, these tests include.

- a. When rubbed between the hands the sand should not crush to fine dust or leave a residue on the palm.
- b. Assessment of the natural angle of repose of the sample of sand. The sand should be capable of holding a profile of, or exceeding, the minimum safety angle of 30°.

2-91. Alternatives can be used but approval is to be sought from RITT.

2-92. **Construction.** The core of the bullet catcher or stop butt may be constructed of any stable inert fill material. However, the surface is to be covered by sand. The depth of sand is related to the type of weapon fired. For high velocity weapons (see Table 4), the depth of sand measured on a line parallel to the LoS is to be 1000mm (S) 900mm (C). For low velocity weapons the depth is to be 750mm (S) 500mm (C) in the direction of the LoF.

2-93. **Profile.** 34° (600 mils) (S) or greater is the recommended slope for the front face of the bullet catcher to reduce the risk of ricochet. Rounds impacting into, or the natural settlement of the sand, may reduce the slope which must never be allowed to fall below 30° (530 mils) (C) as this will cause some ricochet to leave the RDA.

2-94. **Maintenance.** Regular inspection and maintenance of the sand is critical to the range remaining safe for use. There are several factors to be considered and these are described below. Rotation of the sand within the bullet catcher may prolong the life of the sand. The sand should be replaced when the maintenance of the face becomes difficult. Eventually the sand will need replacing but this is situationally dependent on; type of sand used, usage, weather, and maintenance. The following measures are particularly important:

a. **Profile.** Sand in the bullet catcher is to be raked to prevent tunnelling at the MPI behind targets, to keep the surface of the sand in a loose state and to restore the profile to the slope stated in paragraph 2-94.

b. **De-Leading.** De-leading is undertaken to prevent balling and build-up of bullet fragments. It is critical that the RAU ensure the sand is probed as part of the monthly checks.

(1) **7.62mm.** When large quantities of 7.62mm rounds are fired or there are excessive quantities of jacket and bullet debris, balls of lead and other hazardous debris build up in the sand. The bullets tend to remain intact after impacting into the sand and can fuse together into a ball. Typically, after around 20,000 rounds of concentrated fire in any one lane a ball could form at the MPI. When subsequent bullets striking the ball no longer drive it deeper into the sand, backsplash and ricochet become hazards. It is important that any such build-up of lead is removed before the hazards arise. This can be identified by regular prodding.

(2) **5.56mm.** This round tends to break up on impact at close range causing debris in the bullet catcher. Provided the lead particles and debris are small and well spread over the area behind the MPI, the sand will remain stable, and the probability of ricochet or backsplash will remain low. It is prudent to rotate the sand to ensure that the smaller particles are well spread. If there are any signs of lead balling or debris building up to the extent that a potential backsplash hazard is perceived, maintenance will be required to remove the hazard.

(3) **Other Ammunition Natures.** When other ammunition natures have been fired (such as 9mm, black powder ball or bullet, shotgun slugs etc), the sand is to be monitored regularly to ensure lead does not build up around the MPI. As a guide, the sand should be checked for lead build-up when the slope is raked after heavy use to restore its profile. For a range that is only used occasionally, the sand should be checked monthly or after 20,000 rounds have been fired on a lane, whichever occurs first.

(4) **Black Powder Weapons.** Black powder weapons have a low ME and therefore do not penetrate as deep into the sand. On ranges where the firing of black powder weapons is permitted, particular care is to be taken to avoid lead building up in the sand.

c. **Weathering.** In time, continuous impact by shot will break the sand down to a fine powder which will blow away in the wind or bake hard in the sun. Fine sand will also cause the slope to lose its stability. When this occurs, which will be evident by inspection, the sand will no longer be of the prescribed grade and should be replaced. The following additives and reinforcements have been found useful in maintaining the stability of the sand but may introduce other maintenance issues:

- (1) **Wood Shavings or Chips.** A mixture of wood shavings or chips in proportions by volume of about 2:1 sand / wood helps retain moisture and stability of the mass in sand under canopies. The wood will itself break down in time and more will need to be mixed in.
- (2) **Salt.** Adding 1 - 2% of salt by dry weight of sand also helps retain moisture in the sand and will reduce the danger of freezing in winter.
- (3) **Timber support.** Timber supports in the form of boxes or herringbone within the sand clear of the MPI can assist the retention of the sand profile.

d. **Cleaning.** Sand bullet catchers shall be checked prior to use. The hazard of lead contamination when working on sand bullet traps must be considered. The RAU is responsible for:

- (1) Observing the requirements of the Control of Lead at Work Regulations.
- (2) The safety of working practices.
- (3) Providing the appropriate personal protective clothing and, when necessary, respiratory protective equipment.
- (4) Providing washing and changing areas which avoid cross-contamination of clothing.
- (5) Disposing sand, soil, and debris, which might contain or be contaminated by lead, as contaminated waste in accordance with the Local Authority Environmental Control Department's instructions and MOD Policy.

Granulated Rubber Bullet Catchers

2-95. **Material Description.** The granulated rubber should be used in the same form as sand traps, 34° slope (S), 30° (C) with profile line marked on barrack range side walls. The rubber elements are shredded from rubber that has no steel or fabric reinforcement. Where close engagement is to be conducted (10m or less) a covering material is to be placed over the granulate to reduce ingress of unburned propellant. A covering material will also be required where potentially flammable debris from target frames or their backing, or other sources, can contaminate the granulate.

a. **Construction.** The bullet catcher may be constructed in one of the following ways:

- (1) **Complete granulate rubber bullet catcher.** This is where the whole bullet catcher is formed from granulated rubber. Whilst this is a simple solution it may prove costly.

(2) **Solid inert core.** As with sand bullet catchers, the amount of fill material may be reduced by creating a solid, inert, core upon which the granulate sits. It is critical that the minimum granulate depth is maintained if this method of construction is used.

(3) **Sand core.** This is often used where an old sand bullet catcher is replaced by a granulate rubber bullet catcher. The sand core must not be allowed to mix with the granulate rubber and hence a Terram (or similar) membrane is to be placed between the sand core and the granulate rubber. It is critical that the minimum granulate depth is maintained to ensure that the membrane is not damaged.

b. **Shape.** Shredded rubber with elongated elements removed to produce angular rubber fragments that are of regular shape approximately 10 - 25mm in any direction producing tight interlock properties. There are sufficient suppliers who can meet this requirement, so the RAU is not to accept granulate for bullet traps with any visible contamination or elongated rubber.

c. **Durability.** The rubber material will start to break down to fine particles typically after around 20,000 rounds (of all natures) per lane. With effective maintenance these traps should never need total replacement.

d. **De-leading.** De-leading is undertaken to prevent balling and build-up of bullet fragments. It is critical that the RAU ensure the granulate is probed as part of the monthly checks. The material should typically take up to 20,000 rounds per lane. Monthly prodding of the MPI has the potential to extend the interval for de-leading by disturbing the granulate. This process can help to prevent both balling and the build-up of fine particles. Contractors involved in de leading are to ensure all bullets, bullet debris, fine rubber dust and target debris is removed from the granulate.

e. **Fire hazard.** A formal Site-Specific Risk Assessment is to be produced on each range where rubber granulate is used to ensure all fire prevention measures have been implemented. Advice from the Defence Fire & Rescue (DFR) may be sought where necessary.

(1) Tracer is not to be fired into granulated rubber traps.

(2) On ranges where high rates of burst weapon practices are undertaken, water for dousing the granulate after the firing practice is required. Fully automatic practices exceeding 200 rounds per minute and two hours in any 24 hours may generate a fire in the granulate.

(3) Unless the supplier provides "fireproof" material, rubber granulate is susceptible to fire in certain conditions. The risk of fire may be minimised through good maintenance including minimising the accumulation of fine rubber particles, target debris and ensuring that the rubber granulate employed comprises of no fabric reinforcement.

(4) Thick covering materials, such as rubber tiles or anti-splash curtain, will retain heat in the granulate thus increasing the fire hazard therefore should not be used. Covering materials are to be light weight and thin, such as 3mm rubber sheet.

- f. **Stability.** Due to the interlock properties the 34° slope should remain stable throughout many days of use without raking. Only with a high rate of fire on one lane will a depression become apparent behind the MPI.
- g. **Frost resistance.** The material may be used outside during frost conditions without any change in performance.
- h. **Washout resistance.** The material allows water to pass through it without disruption of the slope.

2-96. **Environmental Impact.** Rounds are captured either intact or in constituent parts, lead dust is not generated in the trap to the same degree as in a sand trap. The rubber granulate should not break up as readily into fine dust like sand so there is no particulate thrown into the air during firing or maintenance of the trap. Like sand, there is no impact noise. The granulate may be recycled many times on site to remove spent bullets the granulate is then placed back into the trap.

2-97. **Maintenance.** Granulate rubber provides some maintenance benefits when compared to sand. These include good interlock properties to help maintain the face angle, lower frequencies of rotation or replacement due to its resistance of breakdown, little or no lead dust therefore lower exposure to significant levels of lead in air for range staff and provides a deterrent of infestation by vermin. Most suppliers can provide a de-leading or replacement service using a recycling process on site.

2-98. **Potential Use.** This material may be used on outdoor or indoor ranges. When used on gallery type ranges it should be used only in shooting in boxes fitted into the stop butt to minimise costs and reduce the area affected should there be a fire. For use near environmentally sensitive or populated areas the addition of a suitable fire retardant should be considered. Complete bullet catches on barrack ranges may be converted to this material.

2-99. **Depth Of Granulate.** The depth of the granulate in line with the LoF for high velocity ammunition is to be 1000mm (S), 900mm (C). For low velocity weapons the minimum depth is to be 750mm (S) 500mm (C).

2-100. **Disposal.** This material may be recycled by the supplier. At no time should the granulate as a whole need to be removed for disposal as the regular maintenance will remove and replace broken down granulate.

2-101. **Risk Assessment.** A formal Site-Specific Risk Assessment is to be produced on each range where rubber granulate is used to ensure all fire prevention measures have been implemented. Advice from the Defence Fire and Rescue (DFR) may be sought where necessary.

Tarmac For Range Floors and Roads Crossing Range Floors

2-102. **General.** Existing range floors and roads crossing range floors may remain as constructed. Their presence, and any technical details (if know) should be recorded on the range file. Where a new tarmac range floor or roads crossing a range floor are to be constructed the specification should meet the requirements set out in this document. Minor repairs, filling in of potholes, and other works affecting a limited area may use tarmac similar to the existing road surface. Major resurfacing or replacement of the road is to be to the specification set out in this document.

2-103. **Construction Requirements.**

- a. The safe ballistic requirements for tarmac apply to the wearing course only. Base, sub-base and other courses are to be determined by a suitably qualified person to meet the load bearing, operational requirements, maintainability, and any other relevant requirements, of the road or range surface.
- b. Hot rolled tarmac should not be used due to the pre-coated chippings being rolled into the
- c. The aggregate size should be 6mm (nominal).
- d. No hard edgings (e.g. as concrete curbs) are to be used. Where edgings are required, they should be of a ballistically soft material (e.g. timber).

2-104. **Non-Compliant Roads.** Where a road crosses the range floor and cannot be constructed to the requirements given in paragraph 2-39, it is to be protected from direct strike. This may be by a small earth bund.

Environmental Bullet Catchers

2-105. Environmental Bullet Catchers are designed to manage levels of metals, predominantly lead, within the danger area of the range. They are provided in instances where an Environmental Impact Assessment has shown that a pollution control measure is required due to the degradation of the rounds, due to soil type, and/or other environmental conditions and considerations. Whilst Environmental Bullet Catchers are for environmental reasons, not ballistic safety, they may become a ballistic safety hazard if not managed and maintained. It is intended that the Environmental Bullet Catcher will contain a significant portion of direct shot, though not all, and it is not intended to neither capture ricochet nor pop-over.

2-106. Environmental Bullet Catchers on Full Danger Area Ranges are to be positioned a minimum of 25m behind the furthest target line, with a suggested maximum distance of 50m, dependent upon available land and any other local siting factors. The Environmental bullet catcher is for a standard range with a level range floor, are to be a minimum of 3m high and are to extend at least 1.5m beyond either flank target. For ranges with site specific considerations such as, but not limited to, rising or depressed lines of fire, raised targets, distances greater than 50m from target line to Environmental Bullet Catcher, RITT are to be consulted.

2-107. Environmental Bullet catchers are to be maintainable; they should conform to the construction criteria for a Stop Butt. They are to have 1.5m of stone free earth on the front with a Shooting in Box that conforms to the specification within this DCOP. The frequency of de-leading of the Environmental Bullet Catcher will be dependent upon a combination of the Environmental Risk Assessment, which will determine how much lead can be accumulated in the Environmental Bullet Catcher before it becomes a pollution hazard, and regular inspections to ensure that balling of rounds does not occur.

Impact Areas

2-108. **General.** An impact area / zone is a temporary or permanent space on a RDA in which specified projectiles may impact, detonate, break up or function. The impact area must be large enough to contain ricochet but have its edge no closer to the DA / Z

boundary than the authorised Burst Safety Distance (BSD) or other hazard distance. In pursuance of the policy set out in DSA 03.OME Part 3 Volume 1 Part 2 to protect the public from the hazardous effects of weapon firing, access to the area must be controlled as directed by the Range Authorising HQ or the RAU. Firing must cease if a member of the public or other unauthorised person is detected entering the impact area. This section outlines the principles of the measures required but the degree of their provision will depend on the risk assessment.

2-109. **Closed Impact Area.** A closed impact area is that part of the impact area known to contain, or is suspected of containing, unexploded ammunition (blinds). The whole area must be fenced, to prevent access, with a demarcation fence or structure provided to separate the cleared area from the impact area and the appropriate warning signs displayed. Access beyond the demarcation fence is prohibited to all persons except those involved in the clearance of ordnance. Where the area must be grazed for environmental or fire reasons, animals are allowed in, but under no circumstances must they be followed in by humans. Approved Prohibition and Warning signs on the demarcation fence should direct "No Entry to Impact Area" and "Warning UXO" or similar wording (the symbol is regulated; the text is not). The RAU should ensure personnel do not enter the area before EOC is completed. Injured animals must be destroyed from outside the Closed Impact Area.

2-110. **Controlled Impact Area.** A controlled impact area is one which is known or thought to contain surface or sub-surface blinds, but due to public rights of access, the public cannot be totally denied. During firing the impact area is closed. When the absence of red flags or lights signify that firing has ceased and the range paths have been cleared, controlled access is permitted. MOD personnel and farmers who have good reason to enter the area must be fully briefed on the specific dangers in the areas for which access is required. The control of access is provided by a combination of well sited warning signs and notices together with flags and, where necessary, way marking or fences to direct or funnel the public away from danger. Actual siting and detail will vary and is dependent upon local awareness and activity.

2-111. **Open Impact Area.** This is an impact area where, with a high degree of confidence, all identified blinds are destroyed after firing has ceased. The range cannot be opened to the public until all blinds are found and destroyed unless the known area of the blind is secured against access until the blind is destroyed. There must be sufficient provision to ensure that during firing the public are warned that firing is taking place and that firing can be stopped when necessary. The range boundary should be clearly and appropriately signed with red flags and lights to indicate when the range is in use.

2-112. **Impact Area Siting.** An impact area is sited to ensure that the probability of a projectile falling outside the impact area is minimal. Target siting and topography need to be carefully considered. Any fence line should, as far as reasonably practicable, be sited out of the firer's field of view. Where the fence passes through close country, a clear strip is to be maintained on the outside of the fence to ensure that the safety signs can be seen, and the public will not be encouraged to cross the fence.

2-113. **Firing Points.** Where weapons are fired that have a rear danger area the RDA is to include the back-blast area and therefore the firing points. In closed impact areas such firing points are located clear of the actual impact area and the fence is extended around them. To ensure personnel on the firing point do not move into the actual impact area, a

smaller demarcation fence should be provided (with warning signs) to separate the RDA and impact area.

2-114. **Gates.** Fenced impact areas will require gates of a suitable size to be sited at strategic points. Gates are particularly obtrusive and only the minimum number should be provided. Where reasonably practicable they should be out of the firer's field of view.

Gates will be required for:

- a. **Clearance and Disposal of Blinds.** Clearance and disposal of blinds, including those in designated areas for public access on controlled impact areas, will be necessary. This may involve armoured earth moving plant.
- b. **Servicing Targets.** How targets are moved into and out of the area needs consideration, i.e. towing or winching.
- c. **Grounds Maintenance.** Tree, shrub, and grass growth may need to be controlled.

Control of Access

2-115. **General.** This section specifies the various measures available used to control access for authorised persons. Control of access for the public is covered in JSP 850. Which method is best suited to a particular site will be apparent from the Site-Specific Risk Assessment, which will be conducted by an appropriate person who is familiar with the site, usually from the RAU. In some cases, the measures are influenced by local Byelaws, sea danger areas and local tradition. The risk assessment will determine the minimum requirement to ensure adequate control measures are in place to effectively control public access into the range danger area. Control of access between ranges on range complexes should also be included in local risk assessments. Where public access is permitted between the MOD boundary and a Range Danger Area (RDA) boundary, warning triangles should be used on the outer boundary indicating troops training and where horses are known to use the area, sudden noise. Prohibition signs and flags / lights in this case are placed at the range danger area boundary. See also DSA 03.OME Part 3 Volume 1 Part 2 that includes more information on Risk Assessments.

Fences

2-116. **Classes Of Fences.** Four classes of fencing are specified for various conditions and levels of access control onto open ranges. BS 1722 provides guidance on fence systems. All are used in combination with signs. The levels of access control are:

- a. To provide demarcation.
- b. To discourage access.
- c. To prevent access.
- d. To provide security.

2-117. **Demarcation.** Demarcation of the range boundary may be all that is necessary in remote areas where there is no immediate threat to life and limb. However, thought should be given to the marking of impact areas and to denote designated routes for public access. Three strand fences or marker posts may be used to denote areas. A demarcation fence is also used inside closed impact areas to separate the firing point from the impact area.

Inter-visible safety signs are to be provided on fencing. Colour coded demarcation posts may only be effective where there is no public access, and all MOD personnel are fully briefed on the location and colour coding of the posts. In areas prone to deep snow or snow drifts, the posts may have to be taller.

2-118. **To Discourage Access.** In a controlled impact area and in areas where occasional public activity may be expected, a fence to discourage access is to be provided. Such fences should not be crossed or climbed through easily. In farming areas where animals graze, stock fencing should be provided.

2-119. **To Prevent Access.** In areas where the hazard is such that the risk assessment determines that uncontrolled access must be prevented, a more substantial fence is required. Chain link is designed in such a way that it is difficult to climb but it is easily cut and unwound. Weld mesh fencing is a more substantial barrier but is more expensive. A suitable fence or barrier must be provided to discharge liabilities in preventing access.

a. **Type of fence.** If there is no evidence of vandalism or of people breaking through existing fencing a chain link fence may be suitable. Where such problems are known to exist a more substantial fence or combination fence may be needed.

b. **Height of the Fence.** The fence must be high enough to prevent access by all but the determined trespasser. In low-risk areas a 1.4m fence is sufficiently high to prevent any people stepping over it from flat level ground. In high-risk areas where people are known to climb existing fences, more substantial fencing will be required.

2-120. **To Provide Security.** Security fences are normally 2m high with canted top section. Refer to local Command security advisors for details.

Signs and Notices

2-121. **General.** MOD ranges and training areas present a variety of hazards that may affect all those entering the area. Risk assessments should identify the hazards and their level of risk. Byelaws place a legal duty on the public to comply with access control measures. Safety signs are provided clear of the hazard to prohibit and warn those at risk of the hazards. Notices are also used to provide additional information and clarification, but they must not replace safety signs.

2-122. **MOD Policy And Current Legislation.** Signs and notices are used in conjunction with fences on boundaries and demarcation lines to prohibit, warn and inform people of the potential consequences of entering MOD ranges and training areas.

a. **UK Signage.** MOD policy is set out in DSA 03.OME Part 3 Volume 2 and in JSP 375. Current legislation, on which MOD policy is based, is The Health and Safety (Safety Signs and Signals) Regulations.

b. **MOD Policy for Overseas.** This is to comply with the local or host nation's procedures on signs and sign posting; however, if that level of safety is less than that provided in the UK, additional signs may be necessary to warn British military personnel. Where there is an interface between British families and a British managed range, it will be necessary to have British signs as well as host nation signs, especially if those signs are in a foreign language.

c. **Legislation.** Signage covering Public Access Legislation is covered in JSP 850. The requirement in JSP 850⁹ is to ensure that training area and range safety signs permit access when it is safe to do so. Signs that have the message “Keep Out” or “No Entry” without qualification should only be used where it is necessary to always prohibit access.

2-123. **Definitions And References.** There are several sign systems in place, each supported by different legislation or regulation. Notices are not regulated and should only be used to inform or supplement safety signs, and not to replace them. The following types of signs may be required on ranges and training areas. The list is not exhaustive, and more details may be found in JSP 375¹⁰.

a. **Byelaw.** The local byelaw is a detailed explanation of the rights and measures by which MOD may legally control access to its property. Byelaws take time to come into force due to the consultative process between the local authority, local interest groups and DIO which represents MOD interests. As byelaws are difficult to amend, every effort should be made to predict future changes and requirements at the consultation stage. Byelaws must be displayed at the interface between the track, path, or route where it crosses the range boundary.

b. **Safety Signs.** Standard safety signs are to be provided when the risk cannot be managed by other means. Safety signs are covered in H&S (Safety Signs & Signals Regulations). A safety sign must include a symbol and may have text. However, text alone is incorrect. The design, size and layout of Safety Signs is given in BS ISO 3864-1:2011 Graphical symbols - Safety colours and safety signs. Table 8 shows general examples of these signs. Graphical symbols for use on signs are given in BS EN ISO 7010:12+A5:2017 Graphical symbols - Safety colours and safety signs - Registered safety signs.

c. **Demarcation Posts.** These posts may be used where two levels of risk exist within a range or training area. These should be clearly visible and where signage is not provided their meaning and location is to be explained using a suitable method, to personnel entering the area.

d. **Traffic Signs.** To avoid confusion, roads across MOD property used by the public should be signed as for national public roads. When on public roads these signs are subject to planning controls and are the responsibility of the Local Authority, Land Management Services (LMS) are to be consulted. In the UK signs are regulated by the Traffic Sign Regulations and General Directions 1994.

e. **Notices.** Notices, such as "OUT OF BOUNDS", are not regulated and they are used to inform or provide additional information. MOD has traditionally used combinations of red and white for background and lettering but in rural areas MOD may be encouraged to use other colours. Notices are not to be used instead of safety signs but may supplement them.

f. **Night Signing.** Although red lights are used when a MOD range is in use at night, it may be impracticable to use lights or illuminated signs around or across a training area. However, traffic signs on roads used by the public through a training

⁹ JSP 850 Defence Lands Handbook





¹⁰ JSP 375 Management of Health and Safety in Defence

area should be in reflective paint. There is no requirement to provide additional signs that a training area is used at night.

g. Way Marking of Public Rights of Way. Refer to JSP 850.

2-124. **Shape And Colour of Safety Signs.** BS ISO 3864-1:2011 defines the colours and shapes of safety signs. Safety signs differ from traffic signs. These are given in Table 9. It is to be noted that signs produced to the previous British Standard, BS 5499-1:2002, may be continued to be used until current stocks are depleted.

Table 2-8 - Safety Sign Colours and Shapes

Geometric shape	Meaning	Safety colour	Contrast colour	Graphical symbol colour	Example of use
 Circle with diagonal bar	Prohibition	Red	White	Black	No entry No access
 Circle	Mandatory action	Blue	White ¹	White ¹	Wear hearing protection Wear eye protection
 Equilateral triangle with radiused outer corners	Warning	Yellow	Black	Black	Warning; Sudden noise Warning: Electricity
 Square	Safe condition	Green	White ¹	White ¹	First aid Emergency exit
 Square	Fire equipment	Red	White ¹	White ¹	Fire alarm call point Fire extinguisher

1. The colour white includes the colour for phosphorescent material under daylight conditions with properties as defined in ISO 3864-4.

2-125. **Approved Signs.** Typical prohibition and warning signs for use on range boundaries are shown in Figs 2 - 12 and 2 - 13. Other common range and training area signs are shown in Figs 2 - 14 to 2 - 15. Fig 2 - 11 gives a guide to sizing for range and training area safety signs however these sizes may not meet the requirements of Annex A to BS ISO 3864; as such either Fig 2 - 16 or the BS should be used and not a mixture of both. If an appropriate symbol is not shown, other symbols may be used provided they are

as simple as possible and omit details not essential to their understanding. Graphical symbols used on safety signs, where practical, are to conform to BS EN ISO 7010:2012+A7:2017 Graphical symbols - Safety colours and safety signs - Registered signs. To maintain conformity on ranges and training areas in the UK, any new symbol that does not conform to BS EN ISO 7010 should be approved by the DRSCSWG. Supplementary text may be added below the symbol to denote one of the categories given in Table 2-8 above.

2-126. Supplementary, Combination and Multiple Signs. Supplementary text may be used in conjunction with a safety sign to aid understanding. Where there are known concentrations of people who may not fully understand English, dual, or even triple language notices may be necessary. A supplementary notice is oblong or square. The background colour shall be white or the same as the safety colour used on the safety sign it is supplementing with the text in the relevant contrasting colour.

- a. **Supplementary signs.** These are where the supplementary text is placed in a separate sign located immediately above, below or at the side of the safety sign.
- b. **Combination signs.** These are where the supplementary text is provided as part of the safety sign, in an appropriately coloured box below or to the side of the safety sign.
- c. **Multiple signs.** As the name suggests these are where several safety signs, along with any supplementary text are displayed on one large sign.

2-127. Lettering Style. The preferred letter style is Helvetica Medium or similar. The initial letter of a sentence or proper noun shall be upper case and the remainder in lower case. However, all the letters of a heading, an imperative or a cautionary word may be upper case.

2-128. Sign Size. Guidance to the sizing of signs is given in Annex A of the British Standard BS ISO 3864-1:2011, though this is informative as opposed to mandatory. The key point is that the sign is to be clearly seen and its graphical symbol identifiable by those to whom it is directed.

2-129. Positioning Of Signs. The location, spacing, and sizing of signs will be determined by those conducting the site-specific risk assessment, as the risk assessment will consider local conditions, population and population density, and any other location specific risks. Care is to be exercised in positioning safety signs to ensure that they are displayed where people might reasonably expect to find them, such as at barriers, gates, junctions, clearings, footpaths etc. On long runs of fencing the interval between signs will be dictated by the importance of the information displayed on the sign. In any event people should not be expected to follow a fence for too long before being informed of its significance. MOD policy requires boundary signs to be inter-visible, normally provided at 100m intervals. When demarcation posts are used, these should be inter-visible. Safety signs must not be obscured by vegetation, open gates, parked vehicles, or other obstructions, and must be checked and cleaned at regular intervals. Too many signs can be confusing and should be avoided. Byelaws should provide all necessary details leaving safety signs to emphasise the major areas of concern. Where the public are permitted onto MOD land between the MOD boundary and any Range Danger Area, warning signs with "Troops Training" or similar should be used on the outer boundary and prohibition signs flags and lights at the

range danger area boundary. The aim is to ensure a clear message is passed to the public to ensure their safety.

2-130. **Retrospective Action.** Providing the safety signs exist, the obligation to comply with the Health and Safety (Safety Signs and Signals) Regulations or this DCOP does not require retrospective action but when signs are changed or replaced, they are to conform. To avoid confusion, signs that do not conform to the Regulations or this DCOP should not be mixed with those that do.

2-131. **Boundary Responsibility.** The regional LMS office can advise on the responsibility for fencing, signs, and byelaws notices around the boundary of ranges and training areas.

Flagging / Red Lights

2-132. **General.** There are three common uses for red flags / lights on MOD ranges (Red lights are to be provided where a range is active at night):

- a. **Boundary Flags / Lights.** Traditionally the use of red flags, and at night red lights, around an RDA are used to indicate that a range is in use and / or a residual hazard remains. They are normally located in areas of maximum visibility or next to main access points where signs and notices provide an explanation. The policy is set out in DSA 03.OME Part 3 Volume 1 Part 2. The minimum size for a boundary flag is to be 1.8m x 1.8m. A daytime red light is a suitable alternative to a flag; a site-specific risk assessment will be needed to determine the type and luminance of the light. When using red lights, the resultant control of the boundary is to be as safe as if flags were used.
- b. **Range in Use Flagging.** The range in use flag is hoisted to indicate that the range is in use by troops training. Respective chapters provide advice on the location of these flags. It is important that it is flown in a prominent position on a particular range with local conditions dictating the most appropriate position where they are most easily seen by those approaching a range. Where there is a combination of range types such a one range half converted to CGR only one range in use flag is required unless the ranges are allocated separately. The minimum size for a range in use flag is 1.2m x 0.9m.
- c. **Butt Flag.** The butt flag is used to indicate safe access from and into the Markers Gallery. The flag is to be positioned so that it is clearly visible from all firing points. It is critical that the flag can be raised without the operator breaking cover. The minimum size for a butt flag is 1.2m x 0.9m.

Surveillance and Sentries

2-133. The regulations for surveillance and posting sentries is set out in DSA 03.OME Part 3 Volume 1 Part 2. The requisite works requirements for barriers and towers will be specified in the project brief for the range or training area.

Works Range Structure Inspections

2-134. The range structure is classed as any structure excluding any ancillary buildings which fall beyond the ballistic envelope. Where these structures are present it is the local works organisation who will identify issues relating to legislation, safety, and stability of range structures. A range works inspection guide is provided by RITT for all works officers that have ranges in their areas of responsibility.

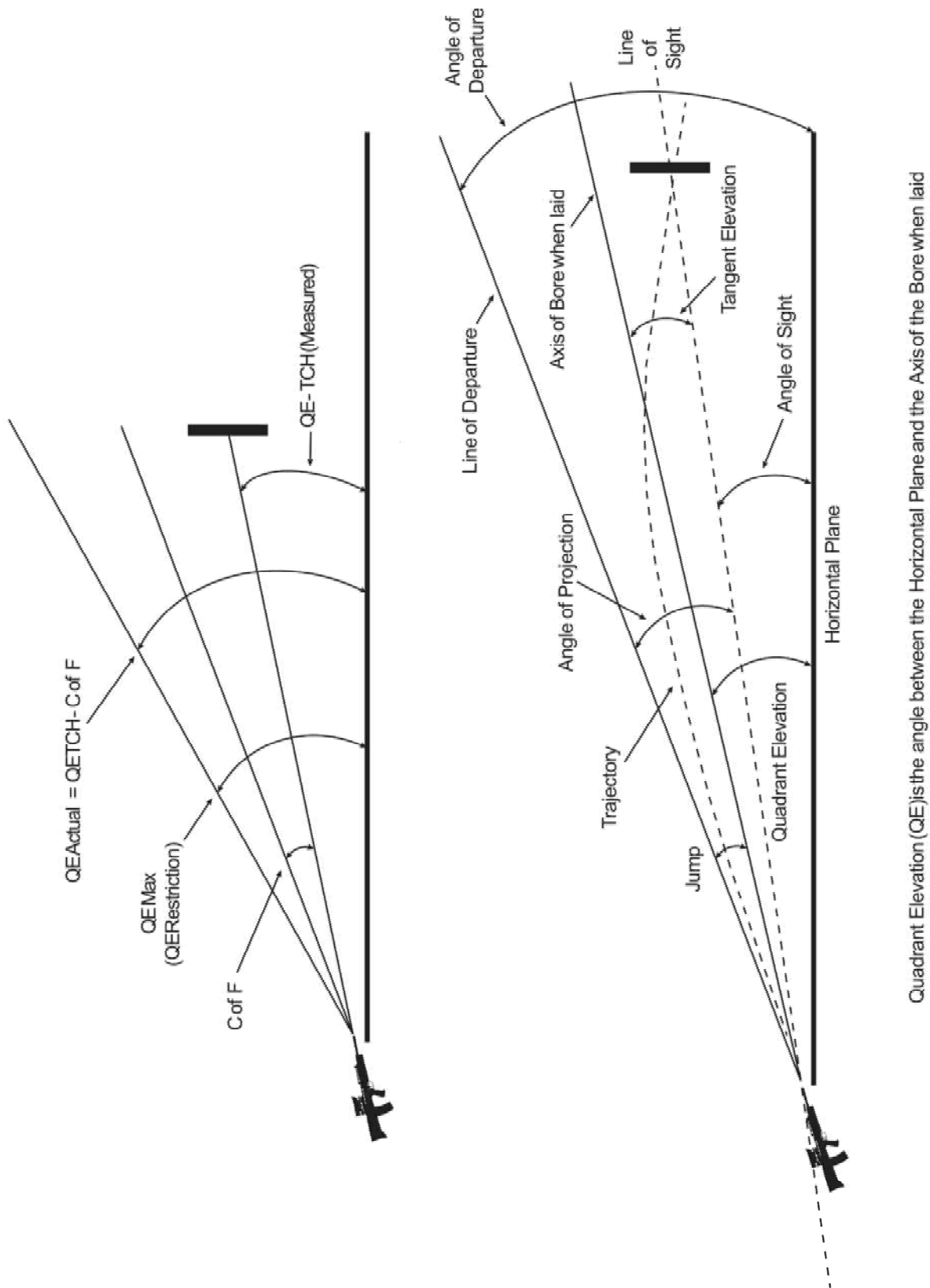
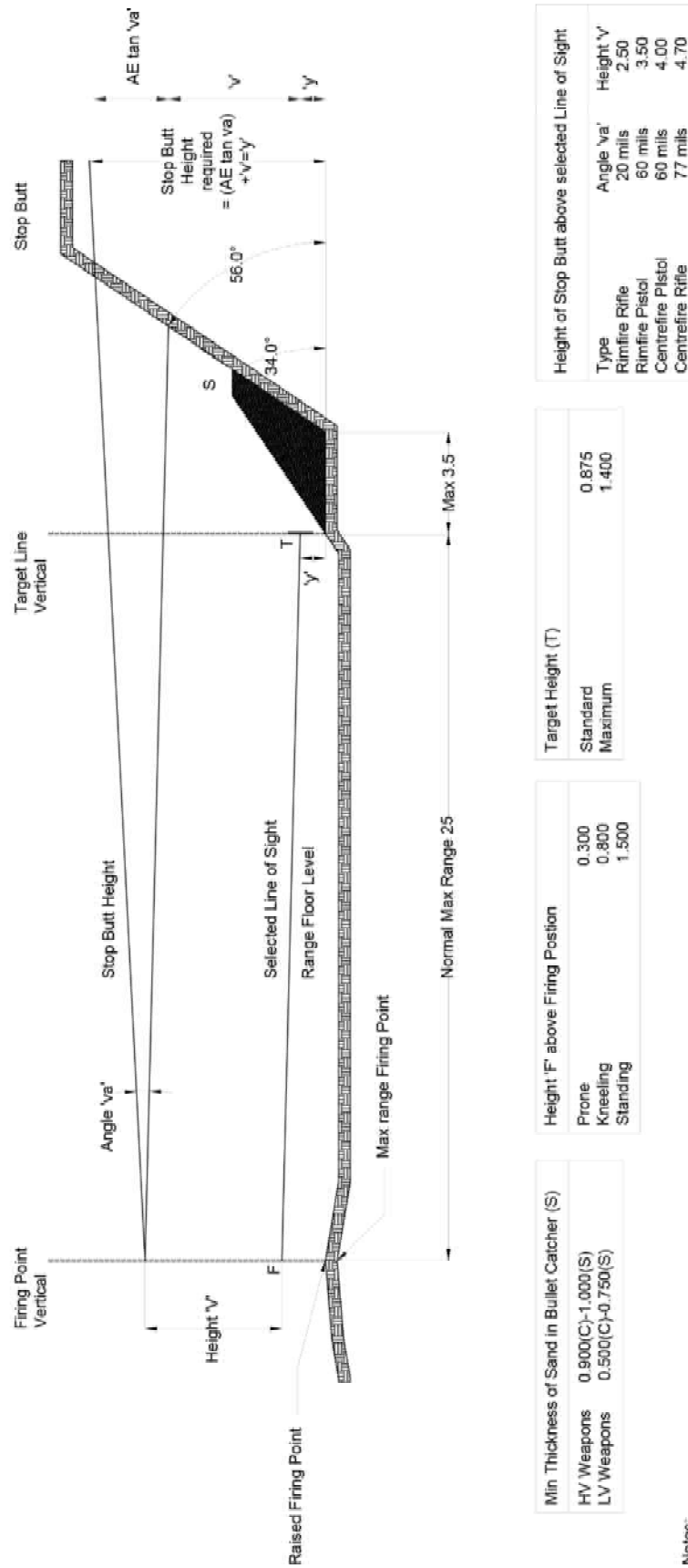

Fig 2 - 6. Ballistic and Design Angles

All dimensions in metres unless otherwise stated



Notes:

1. For ammunition not exceeding MV 1000 m/sec ME 7000J
2. Ricochet pits may be used to reduce the height of Stop Butts.

Fig 2 - 7. Calculating Stop Butt Heights NDA Range (Existing Range Criteria)

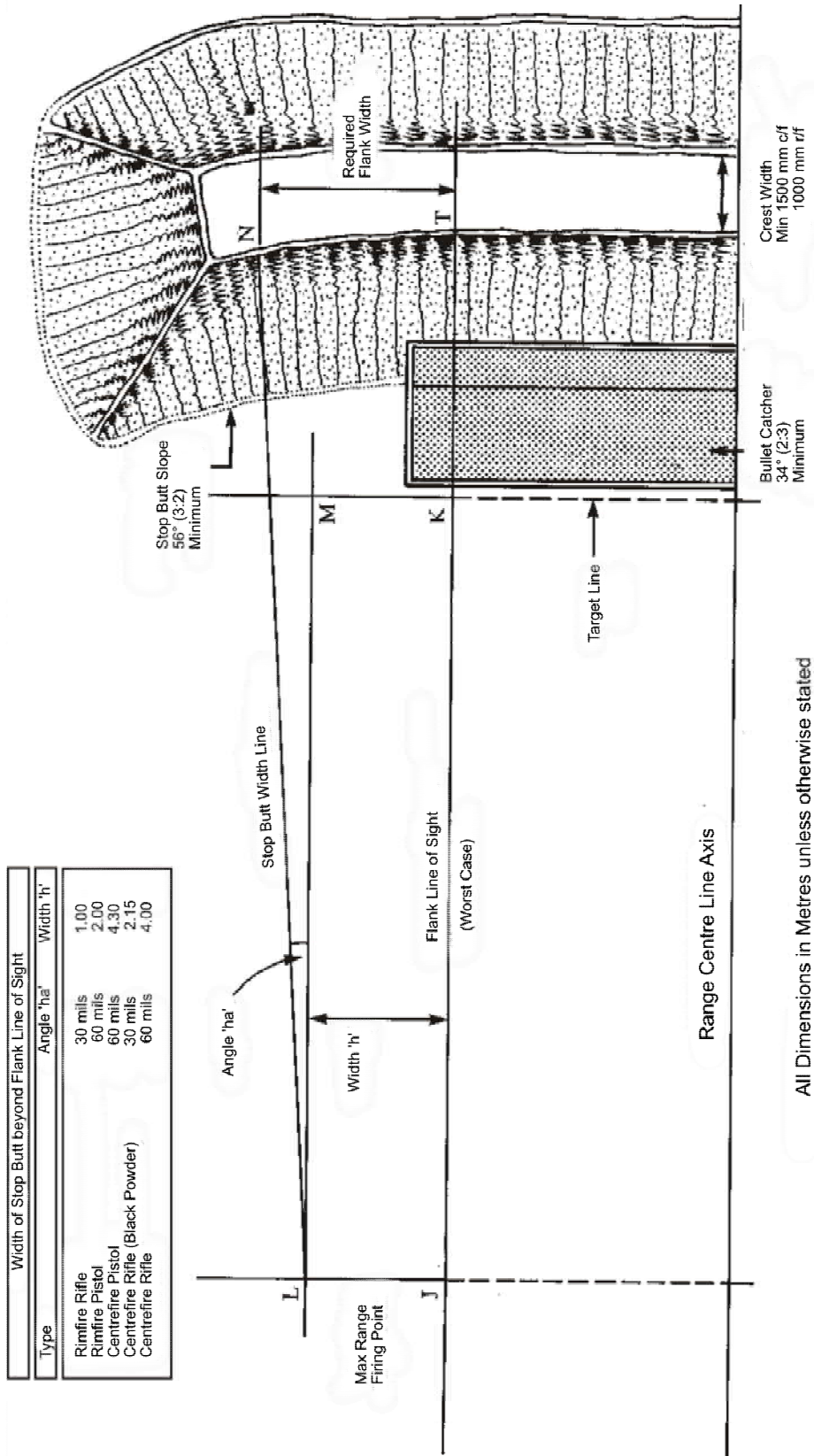

Fig 2 - 8. Calculating Stop Butt Widths NDA Range (Existing Criteria)

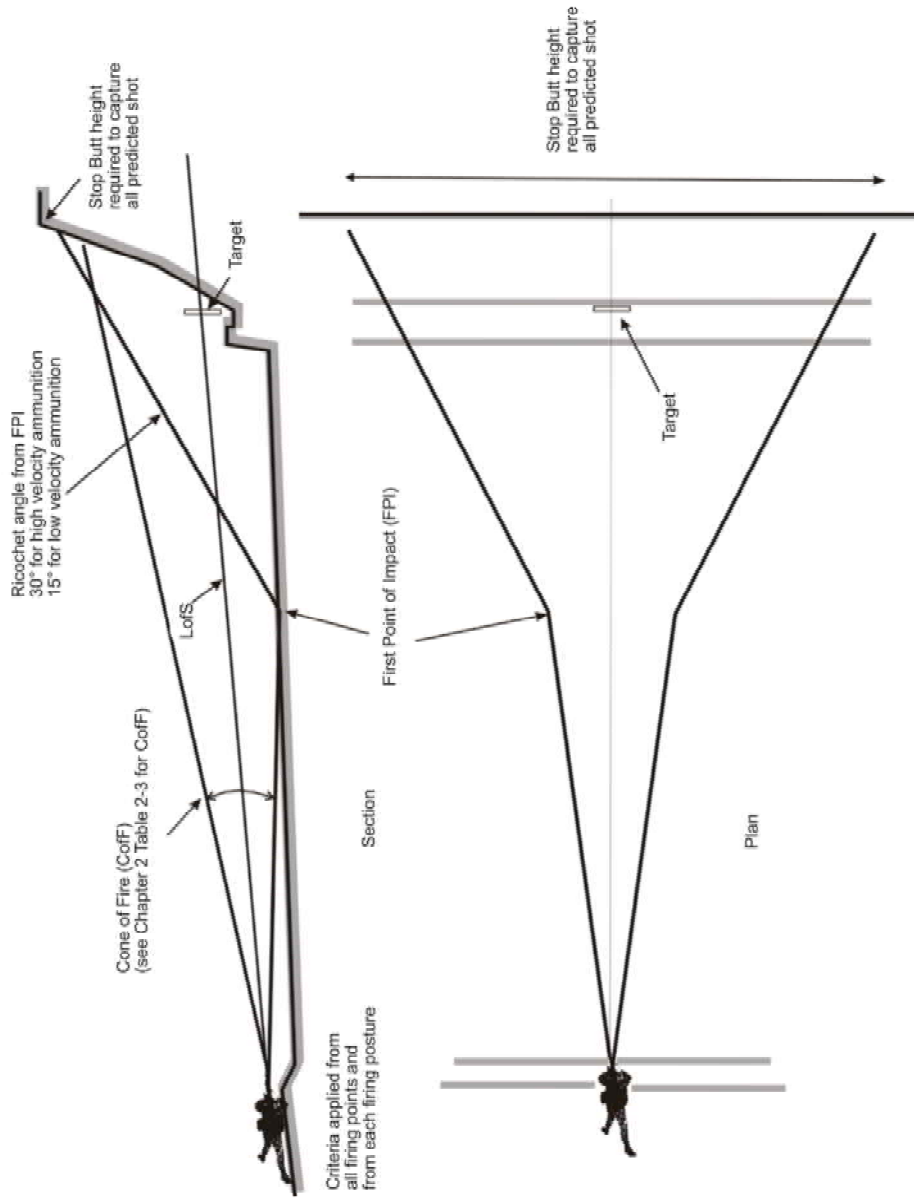
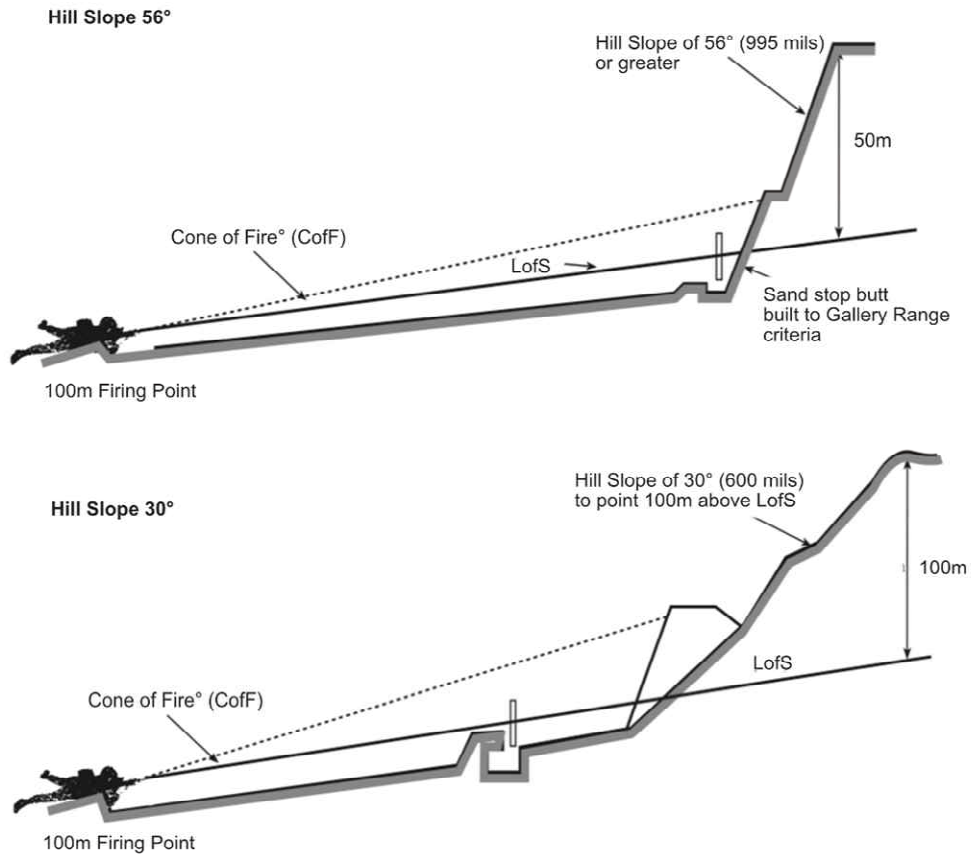

Fig 2 - 9. Cone of Fire Criteria Illustration



Notes

1. The logic behind the hill background criteria applied to a standard range i.e GR, CGR, & ET(LDA)R is that the hill will capture any rounds without inducing further ricochet. No hill provides and even slope. however, to prevent ricochet the slope must exceed 30° (533 mils). Slopes around 30° will generally have areas where ricochet might occur, hence the increased height requirement. Slopes that average 56° (995 mils) are unlikely to have ricochet inducing surfaces and therefore the height is reduced to 50m.
2. Trees and scrub cannot substitute for a hill background. There is no proven data on the ability of trees and scrub to capture high velocity projectiles.
3. On hill backgrounds that rise directly behind the stop butt, all backslash or ricochet inducing material in the hill should be removed or screened.

Fig 2 - 10. Hill Background Criteria



Normally used around the Range Danger Area (RDA) in conjunction with red flags and red lamps at main access points. Where there is sufficient land around the RDA for dry training and or public access, these prohibition signs are placed around the actual RDA with warning signs around the outer MOD or training area boundary. Where this is not the case, these signs are normally placed clear of the actual RDA using natural features such as fences and hedges to help define the controlled area.

Fig 2 - 11. Range Danger Area Boundary Prohibition Sign with Example Text



Fig 2 - 12. Range Prohibition and Warning Signs with Example Text



Fig 2 - 13. Prohibition Signs

Specific Warning Signs



Where a particular hazard is reflected in the specific warning sign examples provided, these should be used. Where there is no specific warning symbol available, use the non specific examples illustrated below

Non-Specific Warning Signs



Fig 2 - 14. Warning Signs



Fig 2 - 15. Mandatory Signs

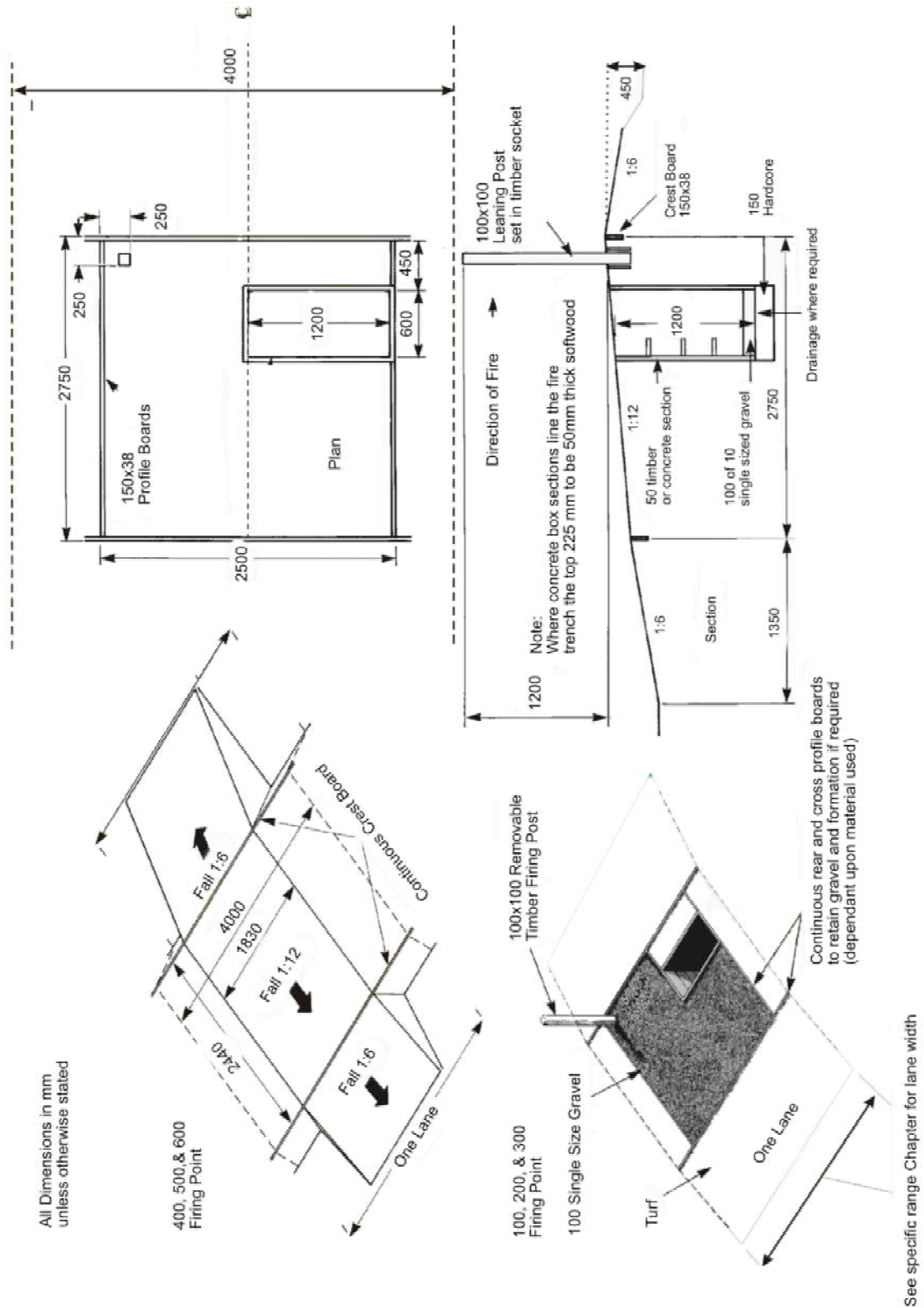

Fig 2 - 16. Standard Firing Point Detail

All dimension in millimetres unless otherwise stated

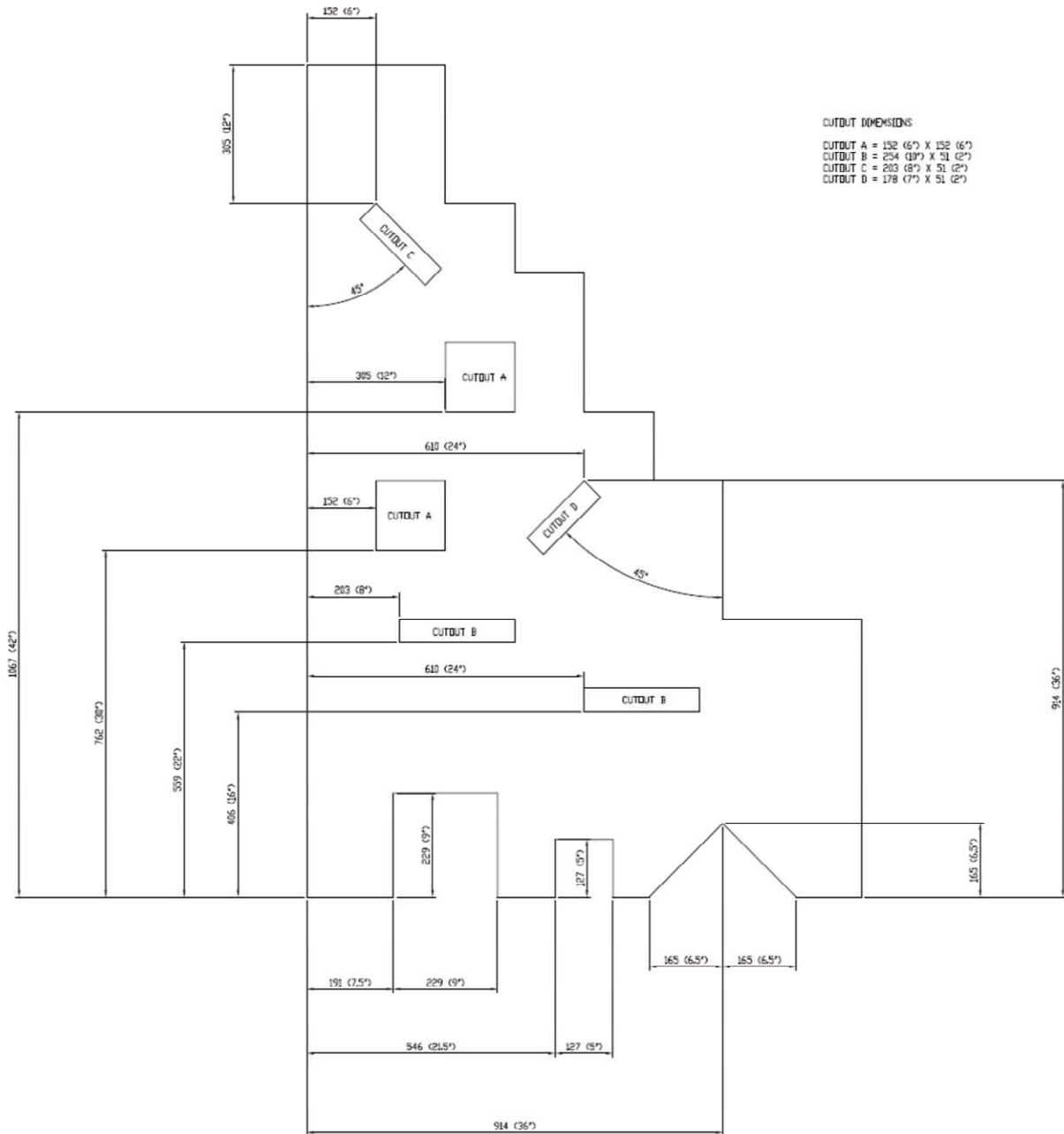

Fig 2 - 17. Tactical Barricade

Chapter 3 - Indoor Ranges

The aim of this chapter is to give the design and construction details for existing and new indoor ranges. Those involved in the planning of new ranges should also refer to the Type Standard. For TERP ranges refer also to Chapter 17.



3-01. **Description.** Indoor ranges are constructed to meet many requirements. The main advantage of indoor ranges is that they provide protection from the elements and external noise can be reduced. The main disadvantage is that noise is more of a problem for range users and weapon emissions become a key safety issue. These disadvantages also affect any range with enclosed or semi enclosed firing points. Indoor ranges may be constructed to meet specific ballistic requirements and practices. Ranges are at times constructed in tunnels or in existing buildings converted for range use. Proprietary, purpose-built indoor ranges can be provided in modular sections or constructed on site. For tactical shooting this Chapter is to be read in conjunction with Chapter 5.

3-02. **Purpose.** The indoor range was developed primarily for rimfire SA which are commonplace with the Reserve Forces and Cadets. There is now a demand for indoor ranges which, like the tube range, allow any authorised centrefire weapons.

3-03. **Environmental Issues.** In all cases Reference shall be made to Chapter 25, Control of Hazardous substances in Indoor Ranges. For ranges where air weapons are used refer to Chapter 22.

Design

3-04. **General.** Indoor ranges present ballistic and potential environmental problems for the designer. The structure must contain all shot without causing damage or injury from ricochet or backsplash. Environmental problems include noise, particularly reverberation, airborne contaminants including lead and carbon monoxide pollution, and unburned propellant. An outline layout of a traditional rimfire range is illustrated in Fig 3 - 1. The backsplash hazard and ballistic limitations are given in Chapter 2 Tables 2-2 and 2-4. Existing ranges were generally designed with a maximum range of 25m. New ranges can be constructed for many situations and distances with the design based on the ammunition nature and using both the vertical and horizontal components of the worst-case firing positions.

3-05. **Components.** The capture of bullets fired in an indoor range relies upon defence structures, the sizes of which are deduced from a series of safety distances and angles. The required degree of protection increases with the probability of strike. The structures (safety features) which produce the level of protection are called components. These and their purpose are:

- a. **Defence Zone.** The Defence Zone (DZ) is the part of a range which may be struck by unintentional shot, ricochet, or backsplash. The zone is specifically designed to resist penetration of the occasional single shot.
- b. **Backplate.** The backplate is constructed behind and around the bullet catcher and is designed to capture predicted shot that misses the bullet catcher. Therefore, the backplate must resist the penetration from multiple direct fire and ricochet strikes.
- c. **Bullet Catcher.** The bullet catcher is designed to stop and contain the majority of direct fire and ricochet and must withstand continuous attrition.
- d. **Floor.** The floor of the range is to have a smooth surface free of any protrusion or indentation which could generate a hard surface ricochet or backsplash.

3-06. **Component Sizes.** The data given in Chapter 2 Table 6 is used to calculate the required sizes of the bullet catcher, back plate and DZ (see also Fig 3 - 2). Chapter 2, Table 7 provides the material thickness considered suitable to prevent single round penetration.

3-07. **Design.** Each component may be sized using the following guidelines:

- a. **Vertical Axis.** The LoS is established by determining:
 - (1) The maximum and minimum target centre height to be permitted on the range.
 - (2) All firing postures applicable to that range:
 - (a) Standing 1500mm (C).
 - (b) Kneeling / Sitting / Squatting 800mm (C).
 - (c) Prone 300mm (C).
- b. **Horizontal Axis.** The LoS is established from the centre of all flank firing positions to that flank target centre. The distance and angle found in Table 6 is projected to determine the minimum width of the range component.

Notes:

- 1 If a raised firing point is to be used, its height is to be added to the firing posture height.
- 2 The LoS from all firing postures is projected from all firing distances to all appropriate target centres. From the line so produced, the distance and angle or angle taken from Table 6 is struck to determine the height of the appropriate range component.

3 The range component is taken to extend down to the range floor in all cases. Where there are penetrable floors with occupied rooms or services below the defence structure must extend over the entire range floor.

3-08. **Rimfire Rifle Backsplash Hazard.** Care is needed to ensure any structure down the range either stops the bullet or is sufficiently weak to allow the bullet to pass through without great loss of energy. Where a low velocity bullet is decelerated on the way down range it may not penetrate the anti-backsplash curtain and as a result may bounce back to the firing point. To minimise this hazard targets should be fixed with light material e.g. timber 25mm or less, plastic, cardboard, string. Where timber is increased in thickness to capture bullets, it is to be ensured that there is no chance of a round cutting through the corners of the timber generating a backsplash hazard.

Construction

Range Building

3-09. **General.** The length of the building is to be such that it allows for the firing distance plus the bullet catcher, firing point, and room behind the firing point for any range staff and, if required, waiting detail. Space for air handling plant may also need to be considered. Some bullet catchers have bigger footprints than others. Each firing lane shall be in accordance with Chapter 2 paragraph 2-81c. To ensure clear vision of the target and maintain an unobstructed sight picture, a height of 600mm should be provided above the LoS at the firing points and 250mm above the LoS at the target. The clear space to the sides is to be a minimum of 500mm. The floor, ceiling or roof, and all walls within the DZ shall either be impenetrable to direct shots or protected by baffles. The thickness of various types of construction to contain shot is given in Chapter 2 Table 7.

3-10. **Adjoining Rooms.** Where other occupied rooms or passageways adjoin the range, or where the range floor or ceiling separate it from other floors, the complete area of the separating structure must be suitably protected from bullet penetration. Timber floors or ceilings may have to be protected over their complete area, the details of which are given in Chapter 2 Table 7. The reduced material specification for engagement at 125mils (approx. 7°) or less is not to be used where there are adjoining rooms. Noise reduction measures may be required if the adjoining rooms are occupied.

3-11. **Doors And Windows.** In new ranges, the inclusion of windows in the protected area shall be avoided. The inclusion of doors should be avoided though in some instances, such as fire doors, this may not be possible. In existing buildings all windows and unnecessary doors must be sealed up and rendered impenetrable. The range entrance door should be located behind the rearmost firing point. One other door may be required by the Fire Officer, for emergency exit, located down-range, though is to be outside the DZ where practical to do so. All down-range doors within the range should be flush with the wall otherwise the reveal shall be baffled or clad to prevent backsplash. Down-range doors within the DZ are to be impenetrable to any direct fire, ricochet or backsplash with all furniture protected from strike.

3-12. For rimfire rifle ranges, rendering a door impenetrable to direct fire may be achieved either through over-plating or protecting with a baffle. It is considered that a FD30 (or better) fire door is impenetrable to ricochet and backsplash (other door types may also be considered suitable, refer to RITT). Fire doors and fire exits are to be fitted with a panic bolt, fitted so that its status is obvious to the RCO, or a push bar regardless of other locks, fitted so that its status is obvious to the RCO. All down range doors are to be controlled by

the RCO. Where it is possible to open down range doors from the outside, an audio-visual alarm must be fitted. Control measures are required outside the main access door warning against entry when the range is in use. Where a range opens onto a public area, a secondary outer door may be necessary to overcome the problem of vandalism or to reduce noise. Red lights or notices, or a combination of the two may be used to provide the control measures. Where it is difficult to see a red light in daylight a sign on or near the door that indicates "Range in use Keep out" or "Range not in use" may be used.

3-13. **Ventilation.** The requirements for ventilation in all indoor training ranges are given in Chapter 25. New ranges should be designed to minimise the potential for air turbulence, including consideration for the routing of services. For centrefire rifle and ranges with high, or very high, volumes of fire the modelling of the airflow may be required.

3-14. **Dust Control.** Dust in the range will contain contaminants such as lead and unburnt propellant, both cause environmental problems and must be removed. All indoor ranges are to be constructed to minimise the accumulation of dust and ease cleaning. All unnecessary surfaces such as shelves, open cupboards or roof members should be removed or sealed. Walls, ceiling, and floors are to be designed or covered with surfaces which are impervious and easily cleaned.

3-15. **Safety Signs.** The risk assessment for the range will determine what safety signs are required. Details of the signs are illustrated in Chapter 2. In all cases the following signs should be provided, however other signs covered by SHEF will be required:

- a. No Smoking.
- b. No food or drink in the range.
- c. Keep out when range is in use.
- d. Hearing protection to be worn when firing.
- e. Wash hands.

Defence Zone

3-16. **Requirements.** The positions of the DZ within the range structure are shown in Fig 3 - 2. It is essential that all parts of the structure within the DZ are impenetrable to direct shots (see Chapter 2 Tables 7). Alternatively, the DZ may be protected by baffles as specified in paragraphs 3-39 (however see paragraph 3-13 - air turbulence). No services or other obstructions whether temporary or permanent, which could cause ricochet or backsplash, should be in the DZ. Any protrusion unavoidably in this area is to be protected and obstructions clad to prevent backsplash. The area of the DZ is calculated using Chapter 2 Table 6.

3-17. **Fixings.** Any fixings used in the DZ must not cause backsplash or ricochet (see Chapter 2).

Backplate

3-18. A backplate is used, where necessary, to provide added protection around the bullet trap. In low velocity ranges the backplate is the part of the back wall, around or behind the bullet catcher, which is designed to be struck by a poorly aimed shot. The

complete backplate area shall be protected by steel plate except where the bullet catcher is sized to include the backplate. On very narrow or low ranges this area may extend down the sidewalls, floor, and ceiling. The size and thickness of the backplate are calculated using Chapter 2 Tables 6 and 7. The steel plate is to be protected against backsplash. Where timber cladding, or similar, is used hidden attrition should also be considered and avoided or minimised by having a suitable inspection regime, which should be facilitated by providing access to the hidden elements.

Bullet Catcher

3-19. **General.** The bullet catcher must safely stop and contain all correctly aimed shot. There are many variations available. Examples with respective advantages and disadvantages are illustrated in Fig. 3 - 6 to 3 - 8. This Chapter covers traditional down range in lane shooting bullet traps where there is a Mean Point of Impact (MPI) behind each target. For judgmental shooting bullet catchers see Chapter 5. For low velocity ammunition modern environmentally friendly bullet catchers are available and should be used. For high velocity ammunition there are modern propriety trap systems available, but consideration is to be given to the weapon systems and volume of fire intended to be used on the range.

3-20. **The Sand Bullet Catcher.** The traditional sand faced bullet catcher is ballistically suitable for all weapons. Details of sand bullet catchers are provided in Chapter 2. It is however not the ideal solution indoors due to the dust and cleaning problems associated with such traps.

3-21. **Vertical Steel Plate with Anti-Splash Curtain.** Typically used for low velocity ammunition and has the minimum requirements outlined in Fig 3 - 6. In this case the bullet catcher and the backplate are to be firmly fixed to a brick, blockwork, or concrete wall. Steel plates should be mounted so that sheets are flush to each other, preferably with fixings made flush. Any gaps between the steel plates are to be covered with steel of the same thickness as the bullet catcher. Continued strike on the steel plate will cause it to buckle and potentially present gaps, where this occurs remedial action will be required. The bullet catcher plates should be so arranged that the target positions will not coincide with the edges of the steel sheet. This design is the minimum requirement for rimfire weapons. It is simple, reliable, and breaks up the round on impact. Backsplash is prevented by an anti-splash curtain in front of the plate. A timber batten on the floor behind the curtain helps contain lead fragments. The size and thickness of steel plate may be determined from Chapter 2 Tables 6 and 7. To minimise reverberation and noise when the bullet catcher is struck, an absorbent layer should be sandwiched between the steel sheet and the back wall. A sacrificial plate should be fitted which will increase durability and reduce the maintenance burden at the MPI, especially if centrefire pistol is to be fired. The sacrificial plate should be fixed to allow for creep. Fixing bolts and screws should be countersunk. A pelmet is affixed round the bullet catcher to stop splat and debris escaping the bullet catcher, refer to paragraph 3-19 for details. The main disadvantages of this trap are noise, and the lead dust generated by bullet impact on the steel plate.

3-22. **Angled Steel Plate With Anti-Splash Curtain.** Suitability for use will be design dependant based upon the ammunition to be fired. This design may include a single steel plate which deflects rounds downwards to a bullet stop at floor level. Deflected rounds may not behave in a predictable manner and there is a much higher reliance placed on the anti-splash curtain. Multiple deflectors of the "Venetian blind" type are only to be used with an anti-splash curtain fixed in front of, and clear, of the bullet catcher.

3-23. **Snail Bullet Trap.** The use of steel ammunition in existing “Snail” traps should not cause sudden failure but inspection of the impact surfaces in the throat of the trap will be necessary to ensure wear is not taking place. The bullet catcher works by directing the bullet into a tight spin allowing the round to decelerate whilst contained within the trap. Lead dust is still produced but is contained. Noise remains a problem with this type of catcher. Such catchers once properly installed should need little maintenance. It is however expensive to install and repair, and the range must be designed to accept the high point loads and component size of the Snail.

3-24. **Granulated Rubber Traps.** The granulated rubber trap used at a natural angle of repose is a very cost effective and environmentally friendly solution. Details of this trap are provided in Chapter 2 and it is illustrated at Fig 3 - 6.

3-25. **Other Bullet Catcher Systems.** There are many propriety bullet catchers available, more for low velocity than for high velocity. Whichever trap system is selected it must meet the following safety.

- a. It must be fit for the purpose for which it was intended. It must capture all rounds safely without inducing ricochet or backslash.
- b. Where centre bull targets are used the trap must be able to withstand heavy localised attrition without excessive deterioration.
- c. The catcher must be easily inspected to provide assurance that penetration resistance is effective.
- d. The bullet catcher ideally should capture rounds intact eliminating lead dust problems in the bullet catcher.
- e. Impact noise should be minimised.
- f. The bullet catcher should require only occasional maintenance and there should be no element that cannot be maintained by range staff.
- g. It should be cost effective in use.

Anti-Splash Curtain (Low Velocity Ranges)

3-26. **Material.** Any bullet catcher that may generate backslash must always be provided with an anti-splash curtain. Only the sand bullet catcher, the Snail Bullet Trap and granulated rubber traps may be used without a curtain. The curtain material is 6mm (S) thick, soft latex rubber or similar material, refer to RITT for details. It is required to resist penetration by a deflected round and to contain backslash without damage to the rear of the curtain. It is known that where there are more than two layers of this 6mm material, 0.22” ammunition may not fully penetrate presenting a backslash hazard. Patching in areas of overlap is therefore not permitted. The use of wadcutter and similar ammunition may render the anti-splash curtain unsafe. These materials are available in a variety of colours, painting propriety anti-splash curtains is not permitted as it may alter the ballistic performance. Where the range is designed for centrefire pistol, a double layer of anti-splash curtain is to be used.

3-27. **Fixing.** The anti-splash curtain is clamped to or fitted with hooks and eyelets to hang it onto, the pelmet to cover the complete area of the bullet catcher in such a way that

deflected rounds or backsplash cannot escape (see Fig 3 - 4). Alternatively, the anti-splash curtain may be fitted into a timber ply sheet covering only the expected area of impact on or around each target. Curtains should be hung in such a way to enable rotation of worn sheets to extend the life of the curtain.

- a. The curtain hangs approximately 300mm (S) in front of the bullet catcher to ensure the rear of the sheet is not damaged by the break-up of the rounds on the steel plate.
- b. It overlaps the pelmet side cheeks which require protection from backsplash.
- c. Each sheet overlaps the adjacent sheet by 150mm (S) ensuring that even if the hanging curtain is not exactly vertical full coverage will be achieved.
- d. To prevent the curtain curling, a timber batten is fixed near the bottom of each sheet, staggered back and front on alternate sheets.
- e. The curtain is to hang just clear of the floor.
- f. A maximum number of two layers of anti-splash curtain is to be used to ensure there is no backsplash. Patching over the areas of overlap is prohibited.
- g. Where a range is used for air weapons it will be necessary to make provision to remove the anti-splash curtain or fit an additional pellet catcher curtain of hessian or similar material. See Chapter 22 for details.

3-28. **Pelmet.** The pelmet is a timber shelf with side cheeks to prevent deflected rounds or backsplash escaping. The inner surfaces of the pelmet are lined with 3mm thick steel to reduce the attrition caused by continued strike.

3-29. **Anti-Splash Curtain Repair.** Latex rubber curtain is expensive. It can however have a long service life, even on a heavily used range. The curtain should be moved around to prevent holing at the MPI. Holes in the curtain can be patched once with material cut from another sheet and fixed with a suitable adhesive available from the manufacturer. Precautions must be taken when handling lead contaminated sheets. Latex rubber is inflammable and must be kept clear of heat sources such as target lights.

Targetry

3-30. **Targets.** There are many target systems available for indoor ranges including static projected target or scenic, video film or live relay and computer-generated target arrays. Traditionally fixed target frames are fitted to most indoor ranges.

- a. High Velocity. A Fig 11 target or, ideally, two Fig 11 targets should be fitted per lane. The minimum lane width at the target end, for two targets, is 1.6m to give half target width separation within a lane and a full target width separation between lanes. If this cannot be achieved, Fig 11A or B targets can be substituted. Electrically operated turning target mechanism may be provided to enhance training.
- b. Low Velocity. Typically, National Small-bore Rifle Association (NSRA) multi point competition targets are used in indoor ranges. The minimum lane width at the target end, for a single NSRA type target, is 0.6m to give a full target width separation between lanes.

3-31. **Target Mechanisms.** Target mechanisms should be protected against damage, backslash, and ricochet. The protection required is established from the worst-case line of fire. Fixed target frames are locally manufactured. They should be of lightweight construction with no fixings that may cause ricochet or backslash. Timber used should be softwood and the total thickness not greater than 25mm thick to ensure after penetration there is sufficient energy to penetrate the anti-backslash curtain. Many suitable fixing methods are available for target cards. A convenient target frame can be constructed with cellular plastic board. Further details may be obtained from RITT.

3-32. **Moving Targets.** Moving targets may be possible in some indoor ranges, the arrangement for which must be assessed by RITT as the application of specific safety criteria is necessary.

3-33. **Target Lighting.** For rimfire rifle ranges, typically a simple row of fluorescent strip lights in an angled reflector, set into the range floor, ceiling or surface mounted with baffle or angled component protection will be found adequate for most shooting. Spotlights can be fitted either at floor or ceiling level, but dimming will be required. For high velocity and pistol ranges the level of lighting will need to be determined by site specific requirements.

Floor

3-34. **Floor Surfaces.** Any protrusions that may generate backslash or ricochet on the range floor will require additional protection. Preferred materials are thick rubber, thermoplastic, vinyl sheet or timber. Timber floors should be sealed and have filled joints to prevent a build-up of lead dust and unburnt propellant. For high velocity ranges and those ranges where vehicles may be used on the range consideration should be given to a power floated concrete floor or equivalent. Whatever floor surface is used it must be easy to clean and maintain.

3-35. **Lower Clear Vision Line.** There are to be no obstructions on the floor that interrupt the lower clear vision line (see Chapter 2 and Fig 3 - 3).

Walls

3-36. **Walls And Sound Attenuation.** Selected wall finishes need to be durable to resist the knock and abrasion inevitable in a range. The finish should be smooth, joint-free, and withstand frequent cleaning and wet scrubbing with agents to remove and neutralise lead dust and unburnt propellant. For centrefire ranges, walls outside the DZ should be clad with a sound attenuating material which will effectively reduce reverberation. The DZ should also, where possible, be similarly clad. It will be necessary to consider the effect of strike on the material selected for the DZ. The detailed design of sound attenuation may vary considerably from one building to another. Raking in the walls and stepping back for services will also provide some reduction in reverberation back up the range. Rimfire ranges will not require such a high level of attenuation as centrefire ranges, but the effect of noise cannot be ignored.

Ceiling

3-37. **Upper Clear Vision Line.** There are to be no obstructions that interrupt the upper clear vision line (see Chapter 2 and Fig 3 - 3).

3-38. **Sound Attenuation.** In buildings with a high ceiling or roof above about 3.5m, sound attenuating linings to the roof or ceiling may be less necessary. With low ceilings or

roofs, sound attenuating lining, or a suspended ceiling may be required. The need for durability and to withstand cleaning, as previously described, is less essential.

Baffles and Timber Cladding

3-39. Baffles and timber cladding consist of a timber facing mounted on battens. The battens provide a gap where the bullet energy can dissipate without damaging the back of the boarding and are fixed vertically to allow bullet debris to drop out.

- a. Purpose. Baffles are used on an indoor range to:
 - (1) Protect fixtures and fittings from strike.
 - (2) Prevent rounds escaping where the walls or roof in the DZ are not sufficient to prevent penetration by shot. The effect of baffles is however limited.

3-40. **Locations.** Baffles are generally placed only to prevent direct shot escaping or to protect fixtures and fittings. They will not eliminate the danger of ricochet in the range due to the random nature of ricochet angles. The range structure within the DZ must in all cases be impenetrable to ricochet. As there is no data for ricochet, use the detail for low angle strike in Chapter 2 Table 7. Baffles may be vertical or horizontal. They are designed with respect to each firing point and from each firing posture for which the range is designed. It must not be possible for the firer to see any item protected by a baffle or to see between baffles which are protecting the DZ. Baffles protecting the DZ are designed so that the soffit of each baffle overlaps subsequent baffles by at least 150mm when viewed as just described. The clear vision height should be maintained below the soffit of each baffle and the clear vision line maintained. Baffles will disrupt linear air flow (See paragraph 3-13).

3-41. **Angled Baffles.** Any baffle in the DZ within the backsplash distance of a firing point is angled to prevent backsplash and to ensure that strike will ricochet down-range and not towards the walls or roof (see Fig. 3-4). Due to the proximity of the hazard and to provide greater backsplash protection, angled baffles should have an enhanced timber cladding as set out in Chapter 2.

3-42. **Materials.** Materials used for constructing baffles are to conform with Chapter 2 Table 7 so that shot penetration is prevented. Cladding to prevent backsplash should be of a suitable ballistic material which allows the round to pass through and to capture backsplash without damage to that material. Where high velocity ammunition is used, particularly steel ammunition, the effectiveness of the steel can be extended by reducing the strike angle below 150. Detail of baffle construction is shown at Fig 3 - 4. For details of timber protection see Chapter 2.

Firing Points and Lanes

3-43. **Firing Points.** When firing is conducted from the prone position on just one firing point a raised platform 450mm (T) high should be provided. This reduces the possibility of ricochet from low shots hitting the range floor. It may be built into the range floor or be a free-standing structure. It should be 2.5m (T) from front to rear with a fall of 1:12 (S) from the front edge. The firing point should be surfaced with a smooth impervious material that can be vacuum cleaned and washed down. Carpets or other items that will trap lead dust and unburnt propellant are not to be used in the range. Where free standing firing

platforms are used marks on the range floor indicating the correct positioning of the firing platform are to be provided.

3-44. **Firing Lanes.** The position of each firing lane should be clearly indicated on the firing point and each lane numbered. Minimum permitted lane widths are:

- a. **Rimfire Rifle.** 1m (C).
- b. **Rimfire Or Centrefire Pistol.** 1m (C) with screens or 1.8m (C) without screens to provide protection from ejected cases and space for coaching.
- c. **Centrefire Rifle.** 1.8m (C) SS or 2.5m (C) A.
- d. **Flank Clear Vision Line.** Each flank clear vision line provides a minimum 0.5m (C) clearance, parallel to the flank LoS, down the complete length of the range (see Chapter 2).

3-45. **Firing Point.** In designing the firing point consideration must be given to:

- a. **Screens.** These assist in preventing adjacent firers being distracted by noise and ejected cartridge cases when firers are close together.
- b. **Coaches.** On any range it is desirable that space is provided for a coach to work beside each firer.
- c. **Range Conducting Officer.** The Range Conducting Officer (RCO) must be able to move freely behind the firers and to have a clear view of all activity on the firing point.

Fire Hazard

3-46. **Hazards.** When specifying materials for range construction, the fire rating must be considered. Materials such as rubber compounds and timber can present a fire hazard. This, combined with factors such as heat from target lighting and the presence of unburnt propellant, require that careful consideration is given at the design stage to fire prevention. A light rubber sheet over granulate rubber traps will prevent target debris and unburnt propellant getting into granulated minimising the fire risk. This is particularly important where close engagement practices are authorised. Means of escape should conform fully to the Fire Regulations.

3-47. **Approval.** Attention is drawn to the Regulatory Reform (Fire Safety) Order for England and Wales; the Fire Safety (Scotland) Act and the Fire Safety (Scotland) Regulations, the Fire and Rescue Services (Northern Ireland) Order. The requirements include a general duty to carry out a risk assessment and take precautions against fire. Fire safety is also covered by the respective Building Regulations (England and Wales; Northern Ireland; Scotland). The advice and approval of Defence Fire and Rescue (DFR) shall be sought for all new or reconstructed indoor ranges.

Communications

3-48. A means of summoning the emergency services, ideally a land laid telephone is to be available.

Maintenance

3-49. **Responsibilities.** Maintenance is the responsibility of the RAU. Responsibilities may be divided as follows:

- a. Range Warden. DSA 03.OME Part 3 Volume 1 Part 2.
- b. Property Management. General inspection with particular emphasis on the:
 - (1) Condition of the range structure.
 - (2) Stability of the back wall behind the bullet catcher.
 - (3) Warning signs and interlock safety systems.
 - (4) Prevention of dust accumulating out of sight.
 - (5) Ventilation system functioning properly.
 - (6) Ensure there is no bullet damage to hard infrastructure.
- c. Equipment Management. Repairing and servicing equipment installed by single Service contract.

3-50. **Frequency.** Proper maintenance is dependent upon good liaison between the Range Warden and the RAU, and on properly scheduled maintenance periods. A heavily used range may need one day's maintenance each week plus one- or two days' maintenance by the Range Warden each month. Two closed periods of a week or so may be needed each year for building and defence structure repair. For frequency of de leading .22" ranges refer to Chapter 25, deep cleaning. Proprietary trap systems should be de-leaded in accordance with suppliers' recommendations.

3-51. **Range Cleaning.** Range cleaning is a critical factor in maintaining a safe range. Range cleaning including the requirements for routine and deep cleaning is contained in Chapter 25.

3-52. **Bullet Catcher.** The bullet catcher, irrespective of the design, will require regular inspection and maintenance. There will be several key elements which are essential to check as part of this regime, these will vary dependant on the type of bullet catcher.

3-53. **Range Structure.** The range structure should be inspected regularly for damage from shot strike. Any strike is to be marked, and the cause investigated and recorded in the Range Log MOD Form 906 series. When such damage in the DZ is significant, it is to be repaired immediately.

Compliance Check

3-54. The following are to be checked:

- a. Authorised weapons, ammunition, and practices.
- b. DZ, backplate and bullet catcher correctly sized and specified.
- c. Floor, walls, and ceiling clearly specified for sound absorption and dust inhibiting surfaces free from obstruction or correctly protected.

UNCONTROLLED COPY WHEN PRINTED

DSA 03.OME Pt 3 Vol 2 Ch 3

- d. Backsplash / ricochet hazards eliminated. Baffles (if any) correctly positioned and detailed.
- e. Targets and firing points correctly sized and positioned.
- f. Target centre height and flank positions clearly identified.
- g. Adequate ventilation and lighting.
- h. Correct safety signs; number and location.
- i. Adequate access and egress.

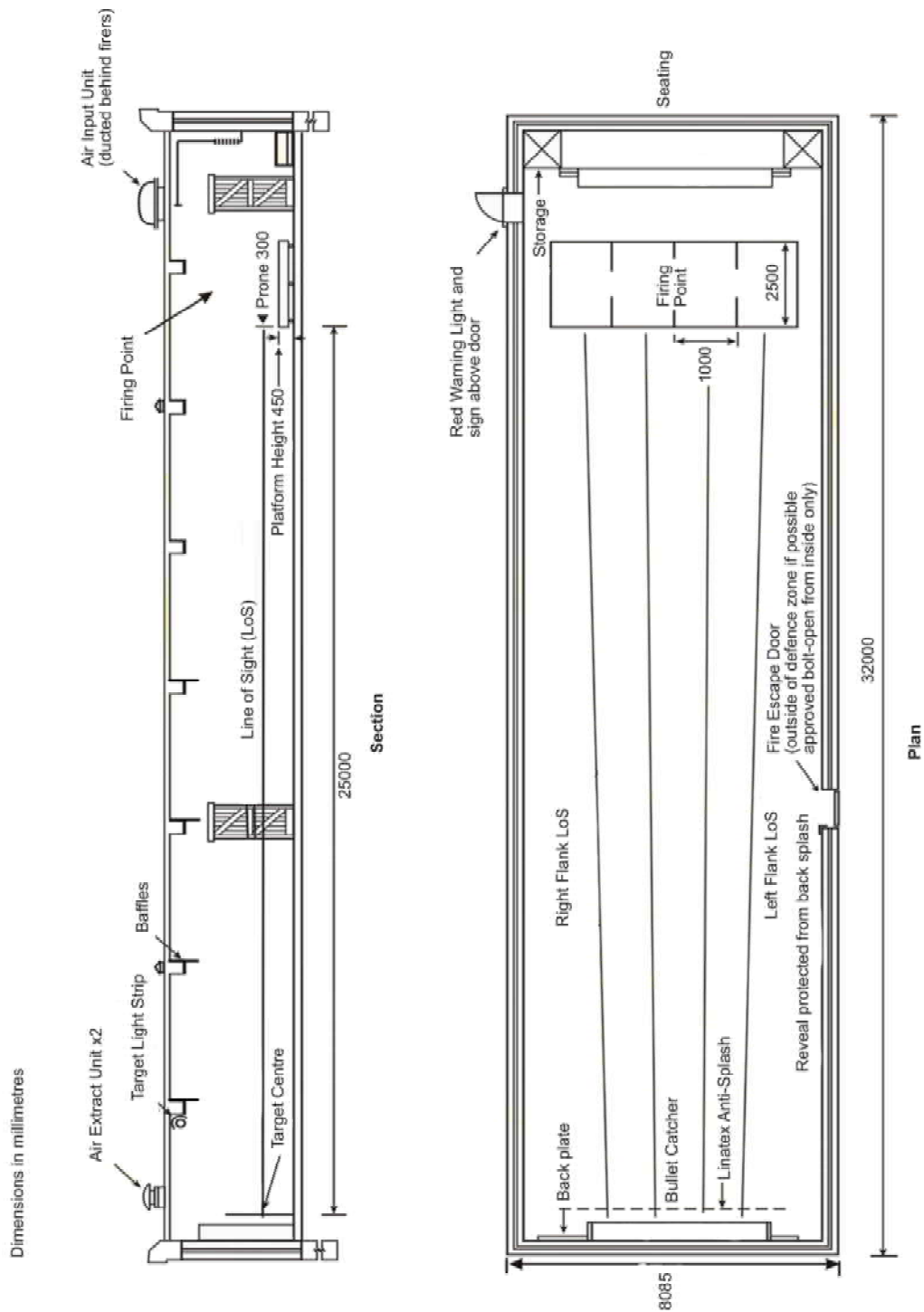

Fig 3 - 1. Typical Layout of a Rimfire 25m Range

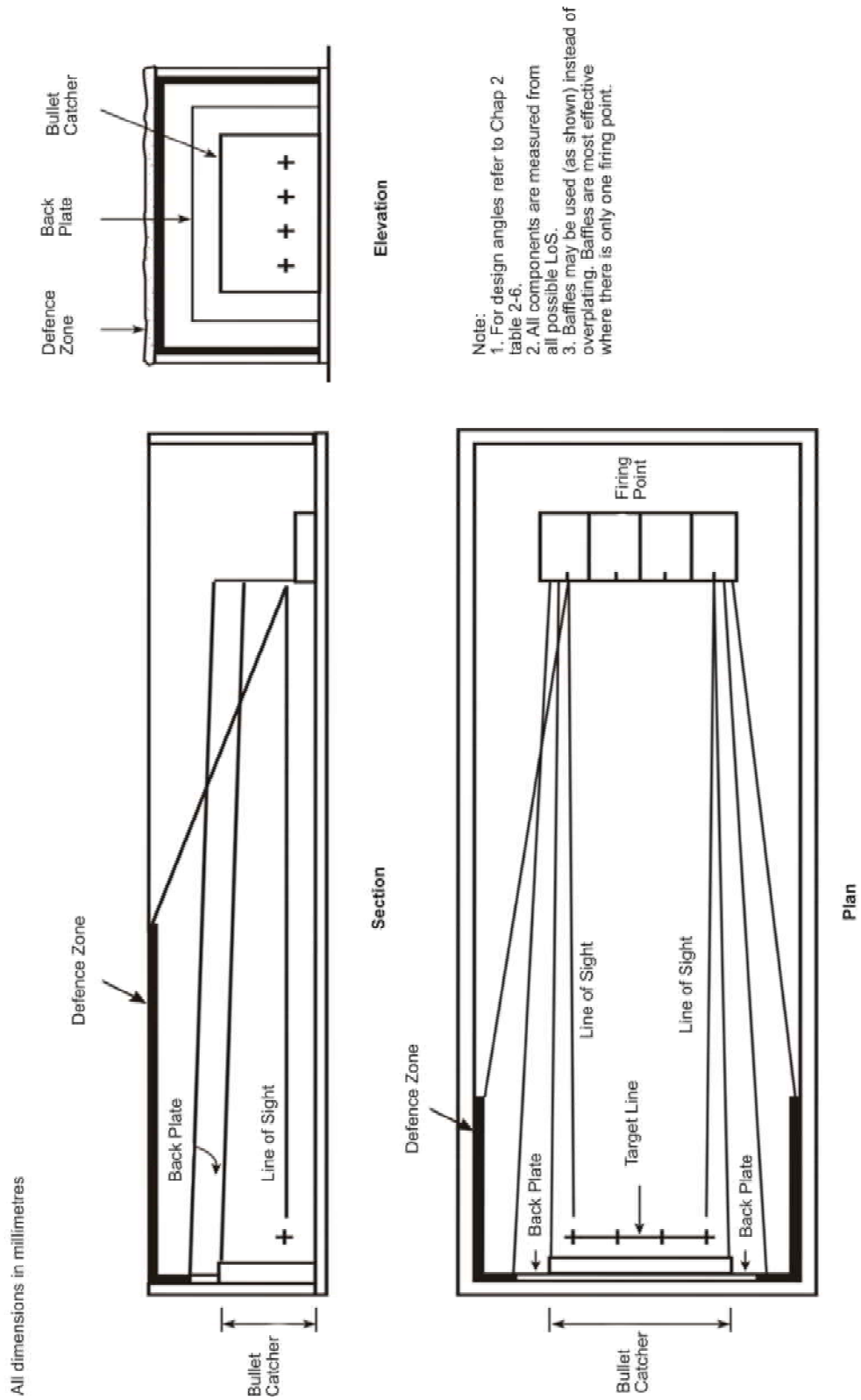

Fig 3 - 2. Defended Structure Details

All dimensions in millimetres unless otherwise stated

Flank clearances are 500mm from each flank LoS to target

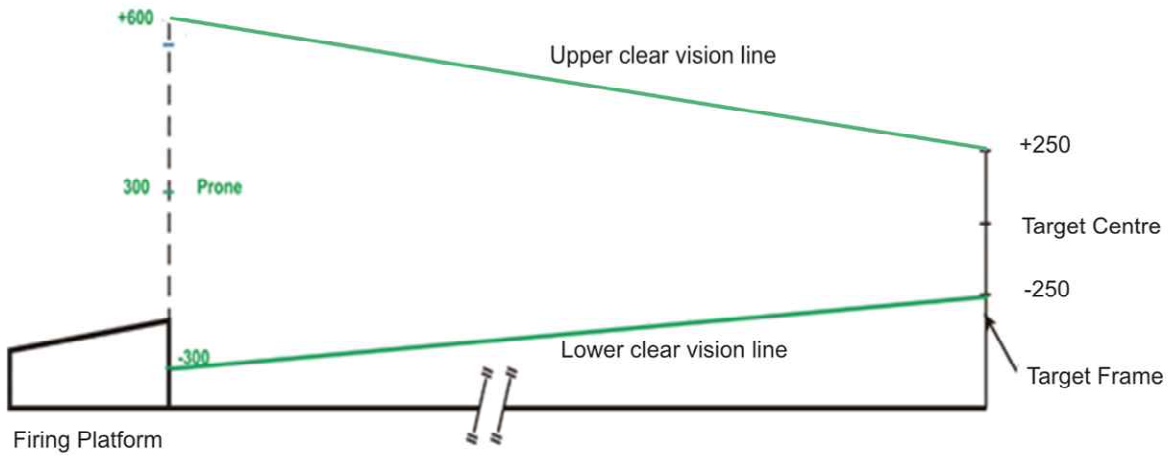

Fig 3 - 3. Clear Vision

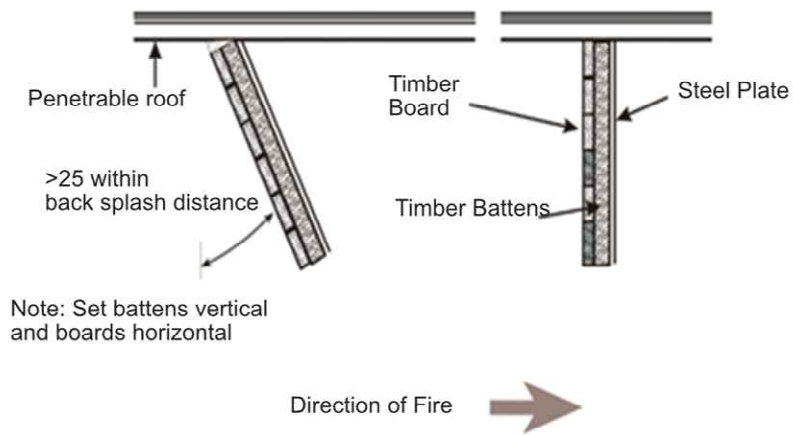

Fig 3 - 4. Baffle Construction

All dimensions in millimetres

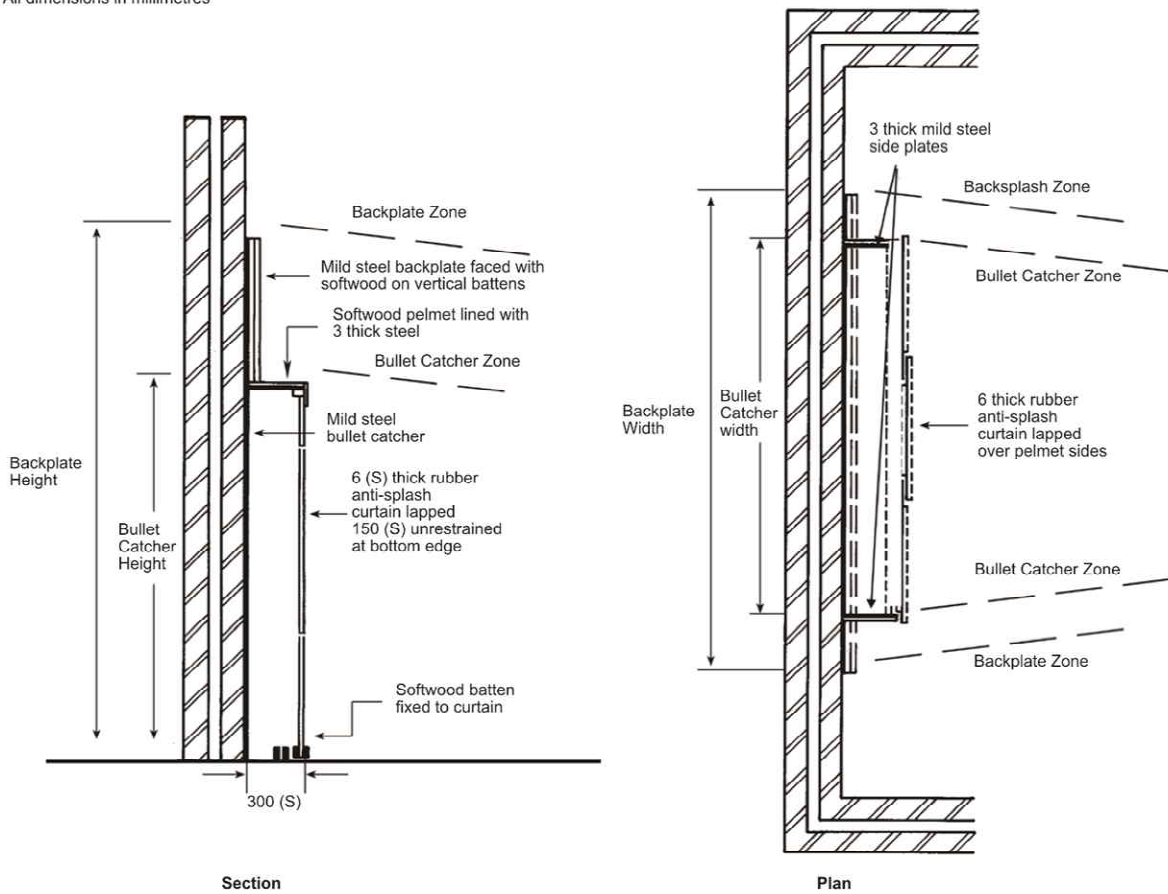
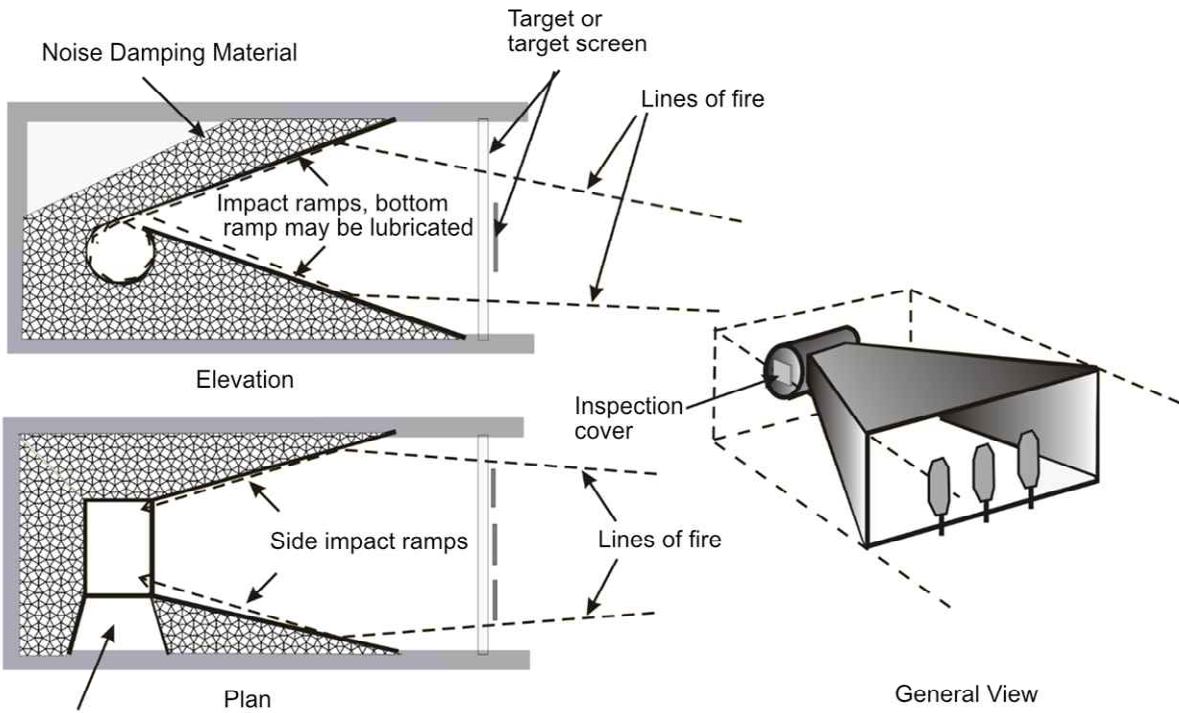
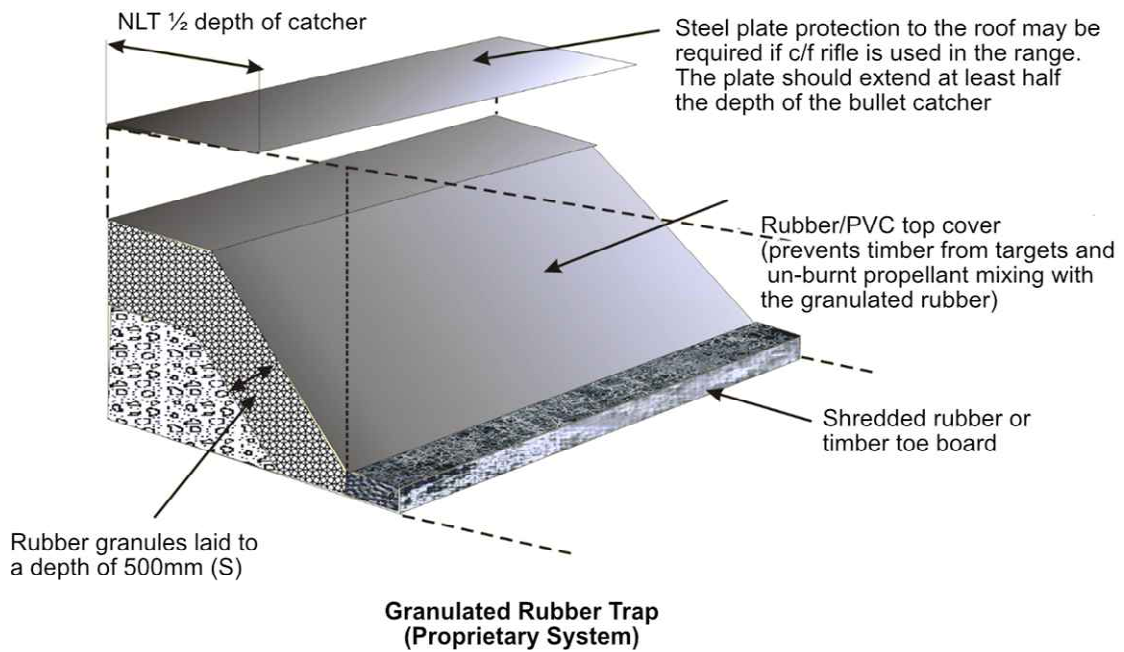

Fig 3 - 5. Bullet Catcher Construction



Access to clean and inspect decelerator chamber

Snail Trap (Proprietary System)



Granulated Rubber Trap (Proprietary System)

Fig 3 - 6. Typical Indoor Range Bullet Trap Detail (High or Low Velocity Ammunition)

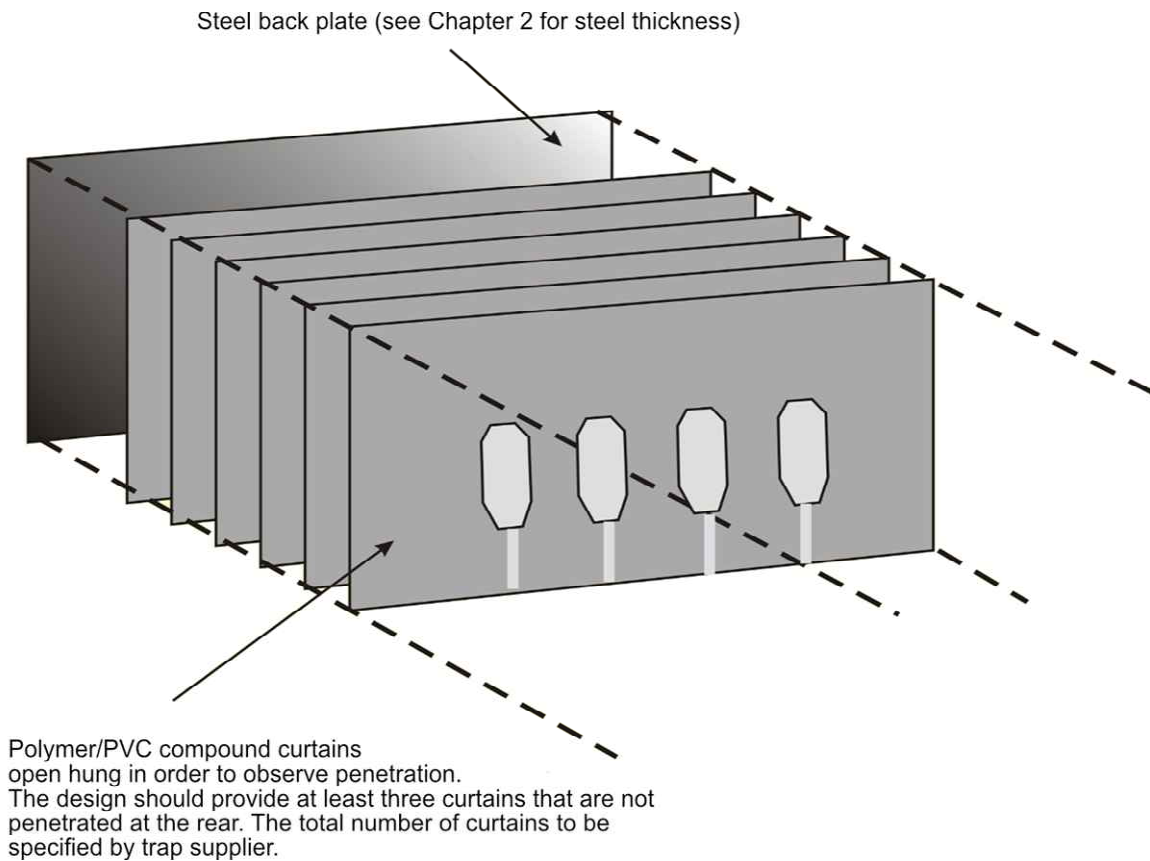

Curtain Trap

Note:
A proprietary system for 9mm or 0.22" ammunition only.

Fig 3 - 7. Typical Indoor Range Bullet Trap Detail (Low Velocity Ammunition)

Bullet Catcher Type	Ammunition type	Advantages	Disadvantages
Sand	All (less Tracer)	Traditional system Inexpensive No noise Suitable for target or judge- -mental shooting Fall of shot visible	Dust in range and catcher (lead & unburnt propellant) Maintenance costs Lead break up Environmental hazard Disposal costs Attrition at MPI
Flat steel plate & Anti-backsplash curtain	Low velocity only	Traditional system Inexpensive Suitable for target or judgemental shooting Small foot print	Dust in catcher (lead & unburnt propellant) Lead break up Cost of Anti-Splash curtain Fall of shot not clear. Attrition at MPI
Snail	All (less Tracer)	Low cost in use Minimal maintenance Suitable for target or judgemental shooting	Lead break up Noise High initial cost Large footprint Fall of shot not clear. Older versions suitable for lead ammo only.
Granulated rubber	All (less Tracer)	Little round break up No lead dust No noise Low maintenance Low cost in use Suitable for target or judgemental shooting	Same footprint as sand Fine rubber dust on high use ranges. Fall of shot not clear. Cover sheet attrition at MPI Fire risk particularly when not fully maintained.
Curtain (Open) Polymer / PVC compound sheet	Low velocity only	No round break up No lead dust No noise Very low maintenance No cost in use (judgemental shooting) Low cost in use (Target shooting) Effectiveness visible	Large footprint Low velocity use only
Curtain / herringbone Rubber recycled conveyor belt	All (less Tracer)	No noise Smaller footprint Suitable for target or judgemental shooting	Attrition at MPI Rounds captured in rubber Effectiveness not visible Anti-backsplash sheet required High maintenance cost for target shooting

Fig 3 - 8. Advantages and Disadvantages of Different Bullet Catchers

Chapter 4 - Non-Standard Range (NDA, LDA and FDA)

The aim of this chapter is to provide advice on the design and construction details for a Non-Standard Range. The range may be either a No Danger Area (NDA), Limited Danger Area (LDA), or Full Danger Area (FDA) Range design depending on the design criteria adopted.

4-01. **General.** The Non-Standard range requires particular attention as each will differ in the way compliance is achieved dependent upon many factors. Therefore, this chapter will define in some detail the process of design to achieve compliance with current authorised criteria. Design principles contained in Chapter 2 are applied to determine the extent of defence structures and range infrastructure.

4-02. **Non-Standard No Danger Area Range.** These are Non-Standard Ranges which do not have a danger area and comply with the criteria set out in this publication, so that the ballistic structures preclude the escapement of correctly aimed shot and any resultant ricochet.

4-03. **Non-Standard Limited Danger Area Range.** These are Non-Standard Ranges initially designed to Non-Standard No Danger Area criteria but do not have a canopy over the bullet catcher.

4-04. **Non-Standard Full Danger Area Range.** These are Non-Standard Ranges which contain correctly aimed shot by the provision of an appropriate danger area. All infrastructure, Cones of Fire, and danger area templates are to be compliant to the criteria set out in this publication.

4-05. **Built To Design Range (BTDR).** These ranges are designed to meet the standards of specific training objectives by MoD personnel which cannot be met by the standard design criteria in accordance with their operational roles and must be endorsed and signed off by the DRSC.

Design Procedures (New or Modified Ranges)

4-06. **Range Safety Advice.** For MOD facilities, any work affecting NDA ranges, whether new build, major refurbishment, modification or major repair is to be co-ordinated with RITT as the Technical Authority for compliance and functional aspects. For non-MOD facilities where this DSA 03.OME Part 3 Volume 2 is used as the design standard, advice on range safety, ballistic resistance and functional aspects may be obtained from RITT.

4-07. **Structural Advice.** Those responsible for the work need to satisfy themselves as to the suitability of the overall design and the competence of those involved in all aspects of design, building or refurbishment work. Design, modification or refurbishment of any structure elements is to be assessed by a qualified and competent person before work is undertaken.

4-08. **Preliminary Planning.** Consultation at an early stage enables provision of advice regarding individual locations and also ensures that planned work complies with functional requirements and standards of ballistic resistance. Detailed ballistic designs, specifications

and all relevant details should be submitted prior to works commencing. All submissions should be forwarded to the local Authorising HQ who will then seek approval from RITT.

Design

4-09. **Siting.** During the preliminary planning process the following hierarchy of factors should be considered for the initial siting of the range:

- a. **Population.** The orientation of the range should be such that where possible the direction of fire is away from habitation.
- b. **Sunlight.** To avoid direct sunlight affecting range users, firing in a northerly direction is preferred. (South in the southern hemisphere).
- c. **Noise.** Since impulse noise such as that produced on an open range is difficult to contain, siting the range at the greatest possible distance from populated areas is the most effective way of reducing noise nuisance.
- d. **Environmental Impact.** Consideration should be given to bullet containment and recycling, the type of structure, materials used and overall appearance of the completed facility.
- e. **Ground Profile.** Ideally Non-Standard ranges should be sited to achieve a Line of Fire (LoF) which is approximately horizontal or slightly depressed from firing point to target, unless it is a specific requirement to differ.
- f. **Local Factors.** Full consideration should be given to local factors, conditions, risks and any other relevant information when formulating site specific design solutions. Distraction visible from the firing point beyond the bullet catcher for instance should be avoided. In some instances overlooking may be a consideration.
- g. **Access.** Access is required for range users and for maintenance works. The range boundary should have controlled access with respective areas suitably signed and, where appropriate, fenced or otherwise marked as described in Chapter 2, Pages 42 to 47, Control of Access. Local assessment of site specific risks is required to determine additional control measures necessary.

4-10. **Range Components.** Full descriptions of individual range components are provided in Chapter 2. Specific considerations to Non-Standard ranges are the following;

- a. **Firing Points.** For longer engagement distances elevated firing points will help avoid ground strike within the predicted CoF.
- b. **Targetry.** A suitable target area with clearly defined target positions provides easily identifiable points of aim. In the design process it is the aiming point of a target that is important. There may be more than one aiming point on a single target therefore the worst case LoS must be applied to each from all possible firing positions.
- c. **Range Floor.** The range floor includes the length from the rear of the furthest firing point to the toe of the bullet catcher and the width between the flank firing points to the extents of any ballistic elements. The area of the range floor should be constructed to eliminate, so far as is reasonably practicable, any hard ricochet inducing materials and surfaces. The layout of the range floor requires detailed

consideration; particular attention is required for each firing point, the likely first point of impact and potential for ricochet from the surface of the range floor.

d. **Ricochet Pit.** A potential for ricochet exists where the appropriate cone of fire criteria coincides with the range floor. The use of ricochet pits, sloping range floors or ground baffles may reduce the size of the structures required to capture ricochet. However, provision of a ricochet pit or ground baffles may restrict the practices that can be conducted on this type of range and may significantly add to the maintenance burden of the range.

e. **Bullet Catcher.** The bullet catcher is the area directly behind the target position which is subject to constant attrition; its purpose is to continually stop bullets in free flight and low ricochet while providing a structure which is easily maintained and cost effective. Sand and granulated rubber are the most common materials used for bullet catchers. See Chapter 2 for recommended details and specifications for both types. For low velocity ammunition environmentally friendly and cost effective in use proprietary traps exist; refer to RITT for details.

f. **Stop Butt.** The stop butt is the area extending above and to the sides of the bullet catcher and should be subjected to lesser concentrations of fire. Its purpose, for NDA ranges, is to stop direct shot in free flight within CoF and ricochet from the predicted first point of impact. Where banks form the stop butt, the minimum impact slope is 56° for high velocity and 34° for low velocity weapon systems. Details are provided in Chapter 2, Figures 2 - 7, 2 - 8 & 2 - 9. For full danger area ranges a stop butt may not be required.

g. **Environmental Bunds.** A bund to capture a significant proportion of direct fire may be required for environmental reasons. Such a bund will need to be maintained and de-leaded and as such it will need to be constructed similar to a bullet catcher. Advice is to be sought from the appropriate Environmental SME.

h. **Protection of Hard Surfaces.** Where exposed hard surfaces or objects are likely to be struck, there is a potential for hard surface ricochet or backsplash to occur. Where the hard surface or object cannot be removed, features should be incorporated to provide protection, for example by the use of timber, earth (sloped at the correct angle) or other suitable material to cover the area of concern. This minimises the risk of injury to those within the range from backsplash and to those outside the boundary from ricochet. Care must be taken to avoid situations where hidden attrition may occur. Rounds passing through soft material leave almost no mark of their passing. However, attrition to the structure behind the soft material may occur and the extent of this attrition may not be noticed until failure of the structure occurs. It is important that all defence structures can be inspected for such attrition to ensure the required protection is maintained.

i. **Danger Area.** A Non-Standard Range can have no, a limited, or a full danger area.

(1) Where the range is built to NDA criteria there will not be an associated danger area.

(2) Where the range is built to NDA criteria but lacks a canopy over the bullet catcher an LDA, as described in paragraph 4-16b, is to be provided.

(3) Where the range is not built to NDA criteria it is to have an FDA template applied, which will be appropriate to the weapon system(s) to be used on the range. The template is to incorporate lines of fire from the extents of all firing points to all relevant targets.

(4) BTDRs will either have no danger area or a danger area developed in conjunction with advice from Weapons Engineering and Safety Centre of Expertise (WESCOE).

(5) Flagging and Signage. Refer to Chapter 2, Pages 42 to 47, Control of Access.

4-11. **Design Factors.** Every element within the range shall be constructed in a way to minimise escapement of shot within the range including direct fire, ricochet and backslash. Any resulting escapement must be contained within a Danger Area.

a. **Direct Fire.** Chapter 2, pages 5 and 6 provides details of the CoF in which all direct fire is expected for MOD shooting practices. Alternative CoF may be appropriate under certain conditions but reductions in the MOD CoF must be authorised in each case to enable RITT to utilise such reductions in the provision of ballistic safety advice.

b. **Ricochet.** (refer to Chapter 2, paragraph 2-40). Ricochet from the range floor has proven to be a hazard and must be accounted for in the design. A ricochet may occur when a round strikes any part of a range surface, other than ricochet inhibiting slopes within the predicted CoF criteria.

c. **Backslash.** Backslash is a hazard to which firers, and others present on a range, may be exposed. It is caused when a bullet strikes any object and results in whole bullets or fragments (of the bullet, targetry, ground or structure) being thrown back towards the range users. Details are provided in Chapter 2, Table 2-2, Backslash Zone (Safety Distances). The risk of injury from backslash is affected by proximity to the hazard, with the level of risk being dependent on the following factors:

(1) **Target Type.** Penetrable (soft) target such as thin plywood, or impenetrable (hard) target such as steel.

(2) **Surface Type.** Nature of surfaces surrounding the target and the range floor - soft or hard. Soft ground and materials include earth, turf, sand, timber etc; hard ground or materials include stone, rock, steel, concrete etc.

(3) **Weapon / Ammunition.** Type used - low or high velocity.

(4) **Engagement Distance.** Target engagement distance or distance between personnel and the object likely to be struck.

(5) **Obstructions.** Objects in the CoF between the firer and target.

d. **Weapon.** The CoF may vary according to type of weapon. This affects the predicted initial point of impact with the range floor.

e. **Ammunition Characteristics.** Ricochet and backslash potential varies with ammunition type; the departure angle and remaining velocity being affected by a

number of factors including calibre, muzzle velocity and energy, nature and slope of the range floor, impact angle, exit velocity ratio, projectile damage and ability to re-stabilise in post ricochet flight.

f. **Posture.** The firing posture adopted affects the relationship between the line of fire and the range floor. Variation in the target centre height has a greater effect on the size of structures required than variation in the firing point height.

g. **Trajectory.** The LoF is a theoretical straight line taken from the muzzle of the weapon through the point (or points) of aim at the target. Bullets do not travel along the theoretical line of fire due to ballistic curve or trajectory; however, for the purposes of calculation the curve is ignored over short distances. Longer ranges with overhead baffles or partially enclosed tube ranges may be effected by trajectory.

h. **Application of Criteria.** To determine LoF, each firing posture height / spacing at all firing distances shall be linked to each relevant target aiming point in accordance with the planned shooting practices. As the constructed elements of a range are affected by application of criteria to these lines, it is essential that every line of fire is considered.

4-12. Component Design.

a. **Bullet Catcher.** The bullet catcher size requirements can be established by application of a parallel distance and an associated angle to the 'worst case' LoF In Chapter 2 Table 2-5.

b. **Stop Butts / Back Walls.** The required height and width of stop butt for a specific range can be determined by applying existing range criteria and relevant CoF and ricochet allowances (See Chapter 2); whichever the greater is to be adopted.

(1) **Cones of Fire.** These are applied to all LoF to determine the extent of direct fire and predicted initial points of impact on the range floor. The stop butt should be sized and positioned to capture all predicted direct shot and ricochet from the range floor. Authorised CoF are provided in Chapter 2, Table 2-3. For BTDRs CoFs specific to that range may be considered.

(2) **Ricochet Allowance.** To determine the extent of predicted ricochet, an angular allowance is applied from the initial point of impact where the appropriate CoF strikes the range floor. In many cases the resultant height and width of ricochet departure angle exceed the direct shot element of the CoF. With careful design of the ground profile it is possible to eliminate or minimise the effects of ricochet by providing a combination of sloped range floor, ricochet pit, and / or raised firing points. The ricochet angles to be used are 15⁰ for low velocity weapons and 30⁰ for high velocity weapons. Angles are to be measured from the range floor where ricochet is possible. For BTDRs a detailed analysis by WESCOE can be undertaken to model the design. BTDRs may also incorporate ground baffles to reduce or eliminate ricochet.

(3) **Existing Range Criteria.** Chapter 2 provides the details necessary to determine stop butt heights and widths using existing range criteria for NDA Ranges. This range criteria is to be used in addition to the cone of fire and ricochet criteria with the resultant highest and widest dimensions used to

determine the stop butt requirements. For BTDRs, WESCOE modelling may replace or be used in addition to Existing Range Criteria.

Construction

4-13. **Firing Point.** The standard firing point is shown in Chapter 2, Figure 2 - 16 and described in Chapter 2, and this should be used as a guide upon which the firing point design should be based. Firing points are to be clearly marked with lane number and distance markers.

- a. The rearmost firing point may be constructed of any suitable material as it will always be to the rear of the muzzle of the weapon. Firing points forward of this may be of grassed earth, aggregate or external quality soft durable surfaces.
- b. Where the prone posture is adopted, the ground level should be raised to elevate the weapon above the range floor. This reduces potential ricochet by increasing the distance to predicted first point of impact, see Chapter 2.
- c. For enclosed or semi enclosed firing points refer to Chapter 3, Indoor Ranges.
- d. Where a movement box is to be used, such as for drive-in ranges, the extents of the box are to be clearly marked.

4-14. **Targets.** Impenetrable targets are not normally used on constructed ranges as this creates problems with ricochet and backsplash. Typical target backing construction is thin plywood, corrugated plastic and hessian screens supported on timber framework, although any similar penetrable construction is acceptable. Only approved targets may be used on MOD ranges. Various forms of target support and mechanisms may be used. Examples include simple timber posts and sockets, hand operated swivel target mechanisms and radio / remote controlled and programmable turning target mechanisms. It is also possible to use pop-up target mechanisms. In all cases the mechanism shall be either penetrable, or suitably protected from strike if consisting of any hard surface. Refer to Chapter 24, Targetry for details on current MOD target systems. On BTDRs targetry may reflect Key User Requirements bespoke to that range but must be considered are part of the range design.

4-15. **Range Floor.** The range floor should be reasonably level, firm, and free draining to prevent ponding. It should have a depth of 150mm (S) topsoil, sand, or other soft material free from stones >30mm (S). Soil should be seeded or turfed to prevent erosion. Particular attention is needed to cover any exposed hard surfaces / target mechanisms on the range floor. Where a hard-wearing surface is required, such as for vehicle drills, the appropriate grade of tarmac is to be used.

4-16. **Bullet Catcher.** If a bullet catcher is required, it should be positioned immediately behind the targets to achieve its function; the distance may vary although 1000mm (T) from target line to bullet catcher toe-board provides sufficient space for access to targetry. As the distance from target to toe-board increases, the defensive structure requirements become greater. Details and specifications of sand and granulated rubber bullet catchers are provided in Chapter 2.

- a. **Profile.** Provided the profile is maintained most bullets should be contained within the catcher, the exception is some high velocity rounds which tend to 'pop-over' - see below.

b. **Canopy.** Where high velocity centre fire rifle ammunition is to be used, an anti-ricochet or 'pop-over' canopy is required to prevent vertical ricochet from the bullet catcher sand leaving the range. The canopy shall be positioned to cover the full width and depth of the bullet catcher. Where the canopy is of timber construction, the rear half of the underside is to be lined with steel minimum 5mm thick across the full width of the canopy. The sides of the canopy are to be impenetrable to ricochet and any debris ejected from the bullet catcher sand and is typically constructed of brick or block. Other materials, such as concrete may be used if they contain "pop-over", are weather resistant and are low maintenance, noting that the rear half of the canopy underside will take the largest proportion of ricochet. The leading faces of the canopy and supporting walls should be clad to prevent backsplash. Where high velocity centre fire rifle ammunition is to be used without a canopy above the bullet catcher, a 100m radius danger area is required to the sides and rear of the range (measured from the flank target positions at sides and stop butt for extent of DA to the rear). Alternatively, the whole area of the bullet catcher may be constructed with a slope more than 56° thus preventing ricochet.

4-17. **Stop Butt.** Typical construction used for Stop Butts include vertical walls, natural earth embankments, manufactured bunds and cutting into natural hill features. The slope angle for an earth embankment stop butt is 56° (C) and 34° (C) low velocity from the horizontal for high and low velocity respectively, which is traditionally accepted as the angle which eliminates ricochet. Other solutions may also be possible.

a. **Positioning.** The stop butt should be positioned as close to the target line as practicable. As the distance from the target line to the crest increases, the stop butt height and width requirement becomes greater to enable capture of all predicted shot.

b. **Protection.** Where a vertical wall is used for centrefire rifle stop butt construction, the area visible above the sand and within the canopy is liable to receive strike regularly and could present a potential for backsplash.

(1) **Concrete or Other Hard Back Wall Surfaces.** Stop butts constructed of hard materials, such as concrete, should be faced with a covering to prevent ricochet and backsplash. Typically, 50mm softwood timber planks on 50mm thick vertical battens is used. Great care is needed to avoid creating potential areas of unseen structural damage, for example bullets may produce only small holes and timber cladding can appear undamaged on the surface, while severe unseen spalling occurs behind. In such cases the cladding should be fixed so that it can be easily and regularly removed to monitor vulnerable areas.

(2) **Brickwork.** Where brickwork is used to create the stop butt, no additional ricochet protection is needed. However, inside the canopy above the sand a render coat, 1:4 mix minimum 12 mm thick, is commonly applied. This is used to identify high shot, indicating problems such as incorrect target centre heights. Where sand bullet catchers are used the render should be continued down behind the sand to prevent moisture seeping into the brickwork.

Communications

4-18. **External.** A means of summoning the emergency services, ideally a land laid telephone is to be available.

4-19. **Internal.** Where manned facilities are available, e.g. guardroom within barracks, communication must be maintained between this facility and the range.

Maintenance

4-20. **Range Profile Survey.** The effects of weathering and soil movement will cause changes in the range profile. Where these changes present a safety concern a re-survey of the range geometry will be required to confirm compliance. New ranges should be re-surveyed 2 - 3 years after construction.

4-21. **Responsibilities.** Maintenance is the responsibility of the RAU. Responsibilities may be divided as follows:

- a. **Range Warden.** See DSA 03.OME Part 3 Volume 1 Part 2, Chapter 1, Annex H.
- b. Property Management.
 - (1) Grounds.
 - (2) Fencing and Signs. (See Chapter 2, Control of Access).
 - (3) Structures, roads, and drainage including stability of slopes and erosion control.
 - (4) Water and electricity supplies.
 - (5) Periodic refurbishment of the range structure.
- c. **Equipment Management.** Repairing and servicing equipment installed by single Service contract.

4-22. **Maintenance Frequency.** Proper maintenance is dependent upon good liaison between the Range Warden and the RAU, and on properly scheduled maintenance periods. A heavily used range may need one day's maintenance each week plus one - or two day's maintenance by the Range Warden each month. Two closed periods of a week or so may be needed each year for

4-23. **Bullet Catcher.** The requirements for maintaining the bullet catcher sand and de-leading are given in Chapter 2.

4-24. **Hidden Attrition.** Where anti backslash or ricochet protection surfaces have been added to hard defence structures, careful and regular inspection of the hard structure is required to ensure that the defence structure is not deteriorating behind the soft cladding. Such cladding must be readily moved to ease inspection.

Built To Design Range (BTDR)

4-25. **Purpose.** The BTDR is a range which is built to a specific design for a particular purpose or training objective. Typically, it will be limited to a set of specific users who will

be defined in Range Standing Orders. Due to the limited nature of this type of range, the range design will only be considered where there is no option to construct a standard range.

4-26. **Design Process.** The BTDR design will be based upon a combination of the standard criteria, where it can be met, modelling by WESCOE, Cones of Fire contained within the user Operational shooting policy, and any other appropriate SME input. The range design is to be approved by the Defence Range Safety Committee Technical Working Group (DRSC TWG).

- a. **Standard criteria.** Where it is possible and practical to do so, the Non-Standard criteria is to be used. Where it is not used, the reasons why should be clearly documented and the alternative method of ensuring safe design is to be specified.
- b. **Cone of Fire (CoF).** There may be occasions when a reduced CoF is required for BTDR, for example Sniper ranges may require a reduced CoF which is not listed in Chapter 2, Table 2-3 – Authorised SA Cones of Fire to be Applied on SA Ranges. BTDR with a reduced CoF can only be used by specific users who are required to meet Collective Training Objectives (CTOs) in accordance with the prescribed marksmanship standards contained in the appropriate shooting policy.
- c. **Modelling by WESCOE.** It is to be noted that WESCOE do not design ranges; they will assess the model produced by the range designer using WDALab and give their findings. The range designer may then use the results, if required, to refine their design to meet the constraints of the proposed range.
- d. **DRSC TWG Approval.** The DRSC TWG provide a committee of SME that can scrutinise the design and proposed control measures. The DRSC TWG will consider foreseeable issues, including but not limited to, use, maintenance, and whether any mitigations from user restrictions (such as reduced CoF) are achievable and practical.

4-27. **Inspection and Compliance Checks.** BTDR's should be inspected and checked against the approved design.

- a. To ensure that such inspections and checks can take place, it is imperative that the As Built drawings are retained on the Range File and are to be made available to inspectors on request.
- b. Any changes post-build is to be clearly documented and accompanied with updated drawings.
- c. Standard construction tolerances should be allowed for when inspecting and checking the range.

4-28. Any changes to the range that may affect the ballistic safety of the range, such as but not limited to, design, practise, weapon systems, or ammunition, will need to have the design reassessed to ensure that it remains safe to use. Any change that may have an impact on the original WDALab model is to be notified to WESCOE to determine if the model needs to be run again. DRSC TWG endorsement is to be sought before any proposed changes are implemented.

Compliance Checks

4-29. The following compliance checks are detailed below:

- a. Authorised weapons, ammunition, and practices.
- b. Firing point alignment, size, positioning and height
- c. Range floor and ricochet pit profile, if applicable.
- d. Mantlet height & profile.
- e. Targets correctly sized, spaced and protected.
- f. Target centre height and flank positions accurately identified.
- g. Bullet catcher sizing and specification.
- h. Canopy construction against 'pop over', if applicable.
- i. Stop butt wall height, width, face angle and crest depth, if applicable.

4-30. For BTDRs the range ballistic elements are to be checked in accordance with the design, which is to be held on the range file.

Chapter 5 - The Close Quarter Battle Range (Urban)

The Close Quarter Battle (CQB) (Urban) (U) live fire range is an advance training facility. It provides a specific form of training in which command and control at all levels is developed in addition to shooting skills in the urban environment. It is primarily intended to provide realistic exercise before operational deployment in an urban area and relates to live fire ranges only. This chapter sets out the design criteria and construction details for constructed CQB(U) ranges and for tactical indoor ranges. For temporary and shoot through facilities refer to Annex A and Chapter 15.

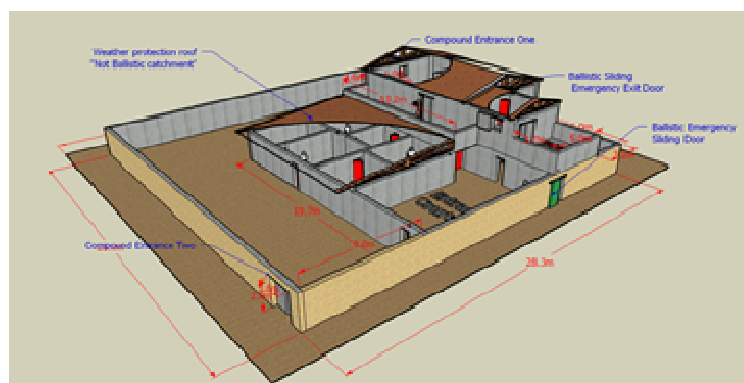

5-01. **Description.** The CQB(U) ranges are constructed to reflect typical urban environments with a variety of realistic scenarios. Domestic and industrial areas, wide and narrow streets, underground services, traffic, and an impression of public activity. The range provides the troops under training with realistic operational situations in and around public activity. There is no set layout for a CQB(U) range. Facilities may be provided in isolation for specific situation training or as a self-contained complex or located alongside existing range areas to incorporate assault and sniper practices in an urban environment.

5-02. **Purpose.** This range provides operational training in the engagement of targets at varied distances in an urban environment including Methods of Entry (MoE), dealing with Improvised Explosive Devices (IED) and judgmental shooting.

Danger Areas

5-03. A combination of WDA templates and NDA principles described in Chapter 4 are applied dependent upon arcs of fire available and range structures.

Design

5-04. **General Concepts.** CQB(U) ranges generally reflect current or projected operational situations. They may consist of a single structure or replicate an urban environment and they may be permanent, semi-permanent or temporary structures. The urban ops skills to be practised in / on these ranges include:

- a. Urban assault - breaching, MOE.
- b. Street clearance - urban patrol skills.

- c. House / room clearance.
- d. IED clearance.
- e. Infrastructure clearance - drains, sewers.
- f. Defence - defended locations.
- g. Fighting within urban areas - collateral damage, judgmental shooting.
- h. Fighting from urban areas.

5-05. **Physical Considerations.** Urban ranges should reflect current or predicted operational environments. Current operations would involve one or more of the following situations:

- a. Limited fields of fire (operating in narrow streets).
- b. Limited observation (by-passing enemy).
- c. Cover from fire and view (making use of urban layouts).
- d. Open areas (exposed to enemy fire).
- e. Industrial buildings (variety of layout).
- f. Towers (sniper activity).
- g. Religious structures (testing rules of engagement).

5-06. **Siting.** These ranges are best constructed on larger training areas with the layout configured to permit firing within prescribed arcs. This also allows more realistic exercise scenarios. Isolated facilities

5-07. **Layout.** A SA loading bay forms the start point of an exercise which also finishes at an unloading bay. These bays are normally contained in an administrative building which also provides preparation, briefing, de-kiting and video debriefing rooms. The range environment simulates the features of potential operational areas. The scenes simulate the features of potential operational areas. Facades of terraced houses, shops, garages etc. form the periphery or outer boundary wall. Buildings are laid out on internal roads with such features as gardens, squares, and car parks to produce the open spaces. Obstructions such as walls, fences, lamp posts and parked cars are included. The layout will be dependent upon and be formulated around a programme of incidents.

5-08. **Special Effects.** Various effects are available to add realism to the urban environment:

- a. **Lighting.** Domestic and street lighting, and enemy headlights are directed to silhouette own troops. Floodlighting may be used as a prelude to an incident in darkened streets.
- b. **Motivations.** Various mannequins throughout the range can be moved remotely to attract attention.

- c. **Missiles.** Rubber bricks simulated petrol bombs and the like may be released in specifically designed areas.
- d. **Sound Effects.** A background of sound effects can be simulated by recordings; for example - urban activity, gunfire and increasing hostility.
- e. **Pyrotechnics.** Examples of electrically initiated pyrotechnics are available for use are:
 - (1) **Splat.** A splat represents a bullet striking a solid surface close to the firer and is operated in conjunction with the blank round fired from the enemy (target) position.
 - (2) **Gunfire.** The Rifle blank firing retaliatory device.
 - (3) **Ricochet.** Used in the same way as splat but gives a ricochet sound effect.
 - (4) **Bomblet.** A small 2ounce gunpowder bag which gives off a large cloud of smoke to represent a bomb.

5-09. All the above effects are remotely operated / activated by the target effects operator in the control tower.

5-10. **Defence structure sizes.** Where there is a need to provide NDA criteria for open ranges the defence structures are designed to meet the requirements set out in Chapter 4. For proprietary NDA bullet catcher systems, the minimum defence structure height is to be 2.4m covering engagements up to 10m with Fig 11 targets at ground level or Fig 12 targets at not more than 0.5m off ground level. For enclosed or semi enclosed facilities the defence zone structure requirements used for engagements over 10m are 120 mils (elevation and azimuth) from the line of sight to target as set out in Chapter 2 Table 6 and illustrated in Chapter 3.

5-11. **Overhead Observation Gantries.** Where overhead observation gantries are provided these are used only to monitor dry run through practices. During live fire activity they are not to be used. Where external engagement is possible the gantries should be constructed with timber and not steel unless the gantry is itself protected from bullet strike.

Range Options

5-12. **Outdoor Open Range Live Fire Tactical Training Areas.** Permanent or temporary CQB(U) ranges may be set up on LFTTAs. Permanent ranges are to be formally established in accordance with DSA 03.OME Part 3 Volume 2. All structures are designed to meet the ballistic and protection standards set out in this DCOP. For this type of range, the following considerations are considered:

- a. **Range Danger Area.** Where NDA criteria is not captured an RDA shall be provided as set out in Chapter 15 Fig 15 - 2 and in 15 - 3 for High Elevation Fire (HEF) targets.
- b. **Air Danger Height.** Where NDA criteria is not captured, an ADH is provided as set out in Chapter 2 Table 1.

c. **Arcs of Fire.** Where there is a limited area for applying RDA, clear arcs of fire are provided. Arcs of fire are particularly important where target designation is not tightly controlled. Targets mounted on roofs or upper storey windows will generate HEF. RDA and ADH in these cases are taken from HEF tables and the worst-case RDA, ADH used.

d. **Structures** (Permanent or Temporary). Where structures or façades are provided on LFTTAs there should be no hard surfaces that might generate ricochet or backsplash. This includes unprotected ironmongery, round head nails, brackets or other fittings or fixtures. All surfaces within the CoF must be of a ballistic material or system. Ballistic materials include any material that absorbs rounds, or an element made up of a hard surface protected by an anti-backsplash curtain or material. Consideration must be given to climatic conditions where this may change the ballistic properties of the material such as surface freezing in colder climates.

5-13. **Outdoor No Danger Area and Indoor CQB(U) Range.** Outdoor ranges should meet the Non-Standard NDA criteria provided in Chapter 4. Outdoor NDA that has enclosed or semi enclosed firing points and all indoor CQB(U) ranges are to consider the emissions detailed in Chapter 25.

5-14. **Indoor Ranges.** All tactical indoor ranges are to meet NDA criteria in terms of the extent of protection. Proprietary solutions for walls, ceilings and other build elements may be used with supplier guarantees of performance based on weapons and extent of use. All indoor CQB(U) ranges are to consider the emissions detailed in Chapter 25.

Construction (Permanent and Semi-Permanent ranges)

5-15. **Materials.** Structural elements may employ conventional building materials or specialist proprietary ballistic materials in areas where targets are to be sited. Facades in areas of expected engagement with small arms and grenades are constructed to absorb shot and grenade fragments, and to eliminate ricochet and backsplash. Where rubber components are used consideration shall be given to the risk of fire particularly where simulated grenades, “flash bangs” are used. In complex covered structures compartmentation is essential to prevent the spread of fire and to provide safe areas in the event of a fire. In more open covered structures consideration should be given to the use of sprinkler systems. Advice from the Defence Fire and Rescue (DFR) at design stage must be sought.

5-16. **Targetry.** Fixed Electric Targets (FET) and radio-controlled targetry may be installed to meet exercise objectives. Moving targets are also possible. Both fall-when-hit and retaliatory devices may be employed. A range of target facings and model figures are available (see Chapter 24). All mechanised targetry will require full protection.

5-17. **Ballistic Wall Options.** To minimise cost, urban live fire ranges may use common building materials in areas where shot is not expected. Celcon blocks are an effective option as they can absorb stray shot and grenade fragments without generating ricochet or backsplash. They will not however take high attrition nor capture direct shot. In areas where shot is expected the following wall or panel solutions that absorb shot without generating ricochet or backsplash may be considered. In heavy use ranges or where concentrated engagement is expected, bullet catchers in front of the structure walls should be considered to extend the life of the more expensive wall solutions.

a. **Sand or Earth.** Sand or earth used in gabion mesh containers, such as DefenCell, or sandwiched between timber may be used as an effective protection wall or backstop for NDA solutions. Table 5-1 below provides an indication on the actual penetration depth to be expected from a variety of ammunition. Penetration close to the surface of such material will be much greater. Any defence structures using these solutions should be constructed with a minimum of 900mm thickness that will allow for some disruption within the structure and still capture rounds.

Table 5-1 - Expected Penetration of Damp Sand and Earth from 5 rounds at a single point of aim

Ser	Ammunition Type	Range/ Angle of Fire	Penetration (see note 1)
1	5.56mm	25m / 900	425mm
2	9mm	25m / 900	365mm
3	4.6mm	25m / 900	195mm
4	7.62mm	25m / 900	480mm
5	8.6mm	25m / 900	540mm

Notes (Table 5-1):

1. Data from DIO SE Penetration Trials Jun 06.
2. Closer engagement is expected to generate greater penetration.
3. 900mm minimum, 1000mm standard depth of sand or earth to capture Infantry small arms ammunition in permanent structure bullet traps.

b. **SACON (US).** A proprietary fibre reinforced concrete supplied in block or panel form. It has a lead leaching inhibitor reducing the potential for lead leaching into the ground. If lead is allowed to build up in this material, it will eventually develop a backsplash hazard. In panel form, panels can be rotated after prolonged use away from target areas. In block form, areas of high use can be cut out and replaced.

c. **TARCON (Turkey).** Like SACON without the lead leaching inhibitor. Less expensive than SACON.



Fig 5 - 1. TARCON interlocking panels

d. **SLABCON** (UK). The original supplier of this material no longer exists however DIO SE have details of a similar concrete mix that is currently used on the .22” urban façade range.

e. **Rubber Panel & Block Systems**. A shredded or vulcanised rubber tile over armoured steel plate system is a common proprietary wall system suitable for all natures up to 7.62mm. Rubber tiles bonded directly to steel plate may present a fire and maintenance problem if sited in areas where regular shot is expected. Tiles provided with a gap between the steel and rubber tile are suitable for judgmental bullet catchers, but the gap extends the depth of wall presenting safety issues on external corners. Target areas or predicted impact areas where bonded panels are used may be protected with a 2nd layer of blocks in front of the structure to capture most rounds fired and allowing block rotation as the blocks become loaded with lead bullets.



Fig 5 - 2. Example - Dura Block™ System using bonded tiles and blocks

f. **Fire Hazard**. Unless specifically stated and certificated otherwise by the supplier, all rubber products are susceptible to fire when engaged with tracer ammunition. Unless documented and certificated “fire-proof” products are used, Range Orders shall reflect the prohibited use of any tracer ammunition and direct that a physical check is made by safety staff prior to exercising units entering the facility. A prominent Prohibition sign is to be placed at the entrances to a rubber facility stating, “TRACER AMMUNITION IS PROHIBITED”. Enclosed shoot house facilities are to be treated as places of work under the Fire Regulations. In addition, the MOD Form 1057 series and 905 must highlight such a restriction of use.

g. **Other Solutions**. Concrete walls protected with timber or rubber tiles; armoured steel plate protected with timber boarding may also be considered but these need intensive maintenance support to remain safe. Stone filled cavity systems are not recommended due to potential settlement of the inner fill.

h. **Moveable Wall or Partition Systems**. To enhance training flexibility facilities may be provided with moveable walls or ballistic wall partitions. Careful consideration is to be given in the design to eliminate the potential of unsafe conditions arising. For details of propriety systems refer to RITT.

5-18. **Bullet Trap Options**. Bullet traps may be used against ballistic walls to limit attrition of expensive materials or form the structure wall itself. All bullet traps must be capable of taking direct fire at close ranges without the need for constant maintenance. In some cases, hidden attrition must be considered.

- a. **Sand / Earth.** Large footprint trap. Smaller footprint gabion or timber solutions are not suitable due to attrition from concentrated fire. Traditional bullet traps are covered in Chapter 2.
- b. **Vertical Rubber Block Traps.** Vertical granulated rubber traps with 500mm depth of granulate can take up to 7.62mm. Rounds are captured within the granulate. Not suitable for small MPI target practices.
- c. **Lamella.** Illustrated in Chapter 3. Large footprint trap. A very efficient and clean trap system but suitable only for .22" and 9mm ammunition.
- d. **Snail.** Another large footprint US proprietary trap. It will take all rounds up to 12.7mm.
- e. **Flat Steel.** 500 Brinell is normally the specification when 5.56mm SS109 is used. Used with an anti-splash curtain offset 300mm or compressed shredded rubber tiles fixed 50mm off the steel plate. A small footprint solution. Panels may be constructed in isolation to provide flexibility in room layout.
- f. **Angled Steel (Venetian Blind).** 12mm armoured steel panels fixed at 450 to impact angle in steel frames. Bullets are deflected down to the bottom of the trap. Panels are loose fitted enabling rotation up and down away from areas of high attrition. Compressed shredded rubber tiles are used to retain ricochet and backsplash. An expensive but long-lasting trap system taking all rounds up to 7.62mm. Panels may be constructed in isolation to provide flexibility in room layout.

5-19. **Method of Entry Techniques.** Specially constructed doors and windows may be required to practice forced entry techniques either on or adjacent to fixed ranges. To use realistic MoE it is often better to provide isolated training structures away from the urban range. There are different techniques for MoE; including mechanical, explosive and shotgun, all of which will have different design solutions. Consideration will need to be given to the MoE which will be required on the facility.



Fig 5 - 3. MoE isolated stands

5-20. **Closed Circuit Television and Public Address Installation.** CCTV may be provided to ensure the safe operation of the range; it can also be used to record exercises and for After Action Review. Cameras may be fitted with IR for night use. A public address (PA) system may be provided to enable the RCO to control the exercise.

5-21. **Range Control.** A range control building may be sited to enable observation and to control exercise activity. In range control provision should be made for the RCO / Exercise Controller, target and effects operators, and video recording operators. Controlled and protected access to the range control and administrative buildings should be provided.

5-22. **Electricity and Water.** Mains electricity and water supply are essential for a range of this type. The provision of a firefighting main should be considered.

5-23. **Ancillary Buildings.** The range requires extensive repair and maintenance which makes a target store and well-equipped workshop essential. Consideration must also be given to the number of waiting troops necessary for an efficient through-put on the range. Waiting areas with adequate facilities will be required.

Maintenance

5-24. **Essential Maintenance.** To maintain a safe facility these facilities, require detailed knowledge of how materials stand up to live fire to determine when rotation, replacement or repair of ballistic elements is needed.

- a. **Ballistic Walls.** In some cases, bullet attrition will not be apparent on the rubber surfaces whilst the steel or structure behind deteriorates from bullet impact. Shot in areas where shot is not expected, or high-volume shot is seen in areas where only occasional shot is expected is to be reported to Range Control.
- b. **Water Ingress.** During winter months any standing water within these facilities will cause a slip hazard. All drains on open balconies exposed to the weather is to be kept clear.
- c. **Services.** Where services are provided within the facility there is a need to inspect for bullet strike damage from direct fire or ricochet.
- d. **Proprietary Systems.** This type of range, especially when designed fir centre fire weapons, often relies on proprietary systems. The systems are to be inspected and maintained to the manufacturers recommendations. Where such recommendations are considered unclear or insufficient in any manner, clarification is to be sought from the manufacturer before installation and the clarified recommendations retained on the range file and also on any other relevant documentation.

Communications

5-25. **External.** A means of summoning the emergency services, ideally a land laid telephone is to be available.

5-26. **Internal.** Provision should be made for the following communications:

- a. RCO to exercising troops.
- b. RCO to safety supervisors.
- c. An intercom for range management between RCO / targets effects operators and video recording operators.

5-27. **Responsibilities.** Responsibilities may be divided as follows:

- a. **Range Warden.** See DSA 03.OME Part 3 Volume 1 Part 2.
- b. **Property Management.** General inspection with particular emphasis on:
 - (1) All facades including supports and access points.

- (2) Observation towers and other elevated structures.
- (3) Electrical safety, alarm, and warning systems.
- (4) Fire escapes in indoor facilities.

c. **Equipment Management.** Repairing and servicing equipment installed by single Service contract.

5-28. **Frequency.** Proper maintenance is dependent upon good liaison between the Range Warden and the RAU, and on properly scheduled maintenance periods. A heavily used range may need maintenance after each use plus one - or two days' more detailed maintenance by the Range Warden each month. Two closed periods of a week or so may be needed each year for structure rotation and repair.

Additional Details for CQB (U) Shoot Through Facilities

5-29. **General.** CQB (U) Shoot Through LFTT facilities are provided for Dismounted Close Combat (DCC) units to practice their Close Quarter Battle (CQB) skills in a LFTT environment.

5-30. The facilities are a cost-effective means of providing realistic and demanding training to personnel involved in the close fight. The facilities may be permanent i.e. constructed and maintained by a RAU, or temporary i.e. erected by a user unit and removed after use.

5-31. **Aim.** These principles outline the requirement, design, and construction of CQB (U) Shoot Through LFTT facilities to ensure structure and layout do not compromise safety.

5-32. **Description.** CQB (U) LFTT facilities replicate compounds that might be encountered on operations. Compounds normally consist of an outer area within which buildings may be positioned. Each building will typically have one entrance and exit and may have several windows. Each building will have a series of adjacent rooms, all linked by corridors. There is no set layout for the compound as they can be constructed to present different scenarios such as factories or small dwellings and even specific locations that may be encountered on operations. Structure layout and target positions, including position of judgemental / friendly targets that would not normally be engaged, are limited only by the available arcs. The compound may be constructed so that more than one team can advance concurrently.

5-33. **Danger Area.** The facilities provide no ballistic protection, and a Range Danger Area (RDA) trace is required to accommodate the Weapon Danger Area (WDA) template in the same way as other conventional LFTT activities. Where the assault team breach into a compound or room no troops are to be forward of the breach.

5-34. **Safety Angle.** Target siting and triangulation is fundamental in ensuring that the individual weapon safety angle is not compromised. Communication between the RCO, safety supervisors and the exercising troops ensures a safe practice and cannot be over-emphasised.

5-35. **Design.** The facility can have several adjoining rooms but are designed in such a way that the rooms funnel the troops in the desired direction. Whilst a room may have

several entrances only one is to be available for use to exercising troops at any one time. Other entrances should be firmly closed and not be used by exercising troops.

5-36. **Construction.**

- a. CQB (U) LFTT facilities are made of penetrable materials. Sometimes Hessian screens are erected but more than likely the facility will be made of sheet timber such as plywood. Whatever material is chosen it is essential, because of the close nature of firing, that no ricochet inducing material is used to support the structure. Metal pickets are to be protected and nails, if used to build the facility, are completely sunk or covered. (See details of nails in Chapter 2 paragraph 2-79e).
- b. Trip hazards are to be kept to a minimum although obstacles may be factored into the compound as part of the tactical scenario. However, there must be no obstacles on the entrances or exits in case of fire, injury or any other such emergency.
- c. Walls may be strengthened to provide the ability to place ladders if required. These areas may require more substantial fixing methods than nails, and these fixings are either to be protected so as not to cause backsplash or to be made of non-backsplash inducing materials.
- d. Targets, including judgemental / friendly targets, are to be entirely penetrable and positioned in such a way that rounds pass through and into the danger area. Elevated targets with target centre more than 90 mils will require the application of the detail in DSA 03.OME Part 3 Volume 2 Fig.15 - 2 with QE max 150 - 1250 mils.
- e. The structure is to be sufficiently robust to withstand inclement weather. The structure must be stable in strong winds.

5-37. **Targetry.** All targets, including judgmental 'no shoot' targets are to be positioned so that firers entering the room engage targets within the arc of fire. Further rooms will present targets in the same manner. This target positioning, together with ensuring supporting troops are behind the line of fire, ensures that the risk is ALARP. Permanent structures are to be handed over to units with no targets present. Range planning staff are then responsible for the positioning of targets so that all firing is within the arc of fire. Only those targets placed by the RCO are to remain in the structure, all spare targets and debris is to be removed to avoid any confusion for exercising troops.

5-38. **Record of Facility.** Permanent CQB(U) Shoot Through LFTT facilities i.e. those constructed and maintained by a RAU, are to be approved by the RAO and recorded on the range's MOD Form 1057 series.



Fig 5 - 4. Typical CQB (U) LFTT Shoot Through Facilities

Chapter 6 – The 25m Barrack Range

The 25 metre Barrack Range is the current MOD standard 25m NDA range design. The range, which has a flat range floor, should not be confused with the 1908 designed 30 yard Barrack Range which has been metricated. The 1908 design has limitations which do not apply to this range. This range may be distinguished by its cantilevered back wall. This chapter sets out the design criteria and construction requirements of this barrack range.



6-01. **Description.** The standard range has six lanes on a flat range floor with a constructed firing point at 25m and further firing positions at 20m, 15m and 10m. Where required it is possible to provide more than 6 lanes on a range although this will increase cost due to the greater span of the front wall over the bullet trap.

6-02. **Purpose.** The barrack range provides a facility for limited firing practices up to 25m. The range is suitable for carrying out the authorised pistol practices, introduction to shooting, remedial training, preliminary grouping, and zeroing, and training sub-unit shooting coaches. Harmonisation Screens cannot be used on this range. To fire CQM practices or pistol practices closer than 10m, modifications will need to be made to the range; refer to RITT for details.

Design

6-03. **General.** The range is intended for use in, or close to, barracks or garrison areas. An increased safety factor has been achieved by moving the top of the stop butt wall forward to over the bullet catcher, which increases the angle from the firing points to the top of the wall, and by providing 11m return wing walls either side of the bullet catcher. Providing access to the stop butt for maintenance purposes is to be considered as part of the design process (see paragraph 6-22). The range design is based on correctly aimed shots going into the bullet catcher, and on capturing all shots fired within the CoF. The range layouts are shown in outline at Figs 6 - 1 and 6 - 2.

6-04. **Siting.** The range requires a flat and level site on firm, well drained land. It should be orientated so that firing is in a northerly direction to avoid direct sunlight affecting firers' vision. Although the range has no DA, consideration should be given to activities and to the population density in the area around the site, particularly down-range and on the flanks.

6-05. **SA Limitations.** Limitations on the maximum number of SA, ammunition and rates of fire that can be used on this range are given in Pamphlet 21. These limitations give

either an increased safety factor under difficult conditions or acknowledge that the design only caters for some practices, and for stable aimed firing.

6-06. **Shot Guns.** The range design is suitable for shot guns firing solid slug or buck shot. Where ranges have significant solid slug practices de-leading frequency may need to be increased to avoid the build-up of lead at the MPI. It is to be noted that buckshot may considerably increase the maintenance requirement on the range due to shot damage.

6-07. **Noise.** Siting a barrack range as far as possible from centres of population is the best way of avoiding noise nuisance. No barrack range should be sited closer than 50m to occupied buildings unless special precautions have been taken to insulate the building against noise. A barrack range firing high velocity weapons should not be within 1km of sensitive buildings such as hospitals.

Construction

6-08. **Danger Area Range.** An NDA range is constructed so that all correctly aimed shot will be captured within the range and that it provides a safe environment for its users. The scale of the structures required represent a higher cost than that of a larger open range with a DA.

6-09. **Dimensions.** A standard 6 lane range is approximately 32m wide and 45m long. Ancillary building and earth bunds may increase the plan area required.

Target Area

6-10. **Stop Butt Wall.** The wall is normally constructed in reinforced concrete, cast in situ. Concrete on the front canopy wall which might be struck is to be clad with 50mm thick timber on 50mm timber battens (for fixing refer to Chapter 2). The battens are fixed vertically to allow debris to drop. It is to be noted that there will be gaps between the timbers to allow for natural expansion and contraction; these gaps are permissible though gaps occurring from damage or degradation of the timber are to be repaired. The inside walls of the bullet catcher chamber are left unclad to allow inspection for strike damage. For repairs to the stop butt wall see Chapter 2. Bullet strikes on the stop butt wall above or beside the bullet catcher are to be recorded in the Range Log (MOD Form 906 series). If such incidents occur frequently, the range configuration may need to be checked by RITT. To ease inspection, the wall should be painted with an external sand or white paint and shot marks made good.

6-11. **Bullet Catcher.** A sand or granulated rubber bullet catcher is contained in a concrete chamber set back into the stop butt wall. The toe of the bank falls just beyond the wall. In this design, the timber anti-splash cladding of the stop butt wall is extended 1m below the top opening of the bullet catcher to prevent backsplash (for fixing refer to Chapter 2). The back and side walls of the bullet catcher chamber are not lined with timber to enable inspection and repair of shot damage to be carried out. It is essential that the height of the bank and the level of timber below the bullet catcher chamber opening are constructed as shown at Fig 6 - 3. This will ensure that the top of the bank is shielded by the anti-splash timber. A line is to be painted, in a contrasting colour, on the back and side walls of the chamber indicate the level of the sand with a 1000mm deep plateau on the top and a 34° or greater (600 mils) slope to the face of the bank. Details of the sand or granulate are given in Chapter 2.

6-12. **Target Centre Position.** The target centre height of 1000mm (C) above ground level at the target line is a key factor in the range design and must be maintained for all targets, excepting CQM multi-point of aim targets (see Fig 6 - 4). A line of contrasting colour is painted on the bullet catcher wing walls to indicate target centres and a line to indicate flank limits beyond which targets are not to be placed (see Chapter 2, 2 Fig 2 - 3). Where CQM shoots are authorised, the multi-point of aim target is to have the centre of the target no higher than the 1000mm TCH; this is to ensure that the upper aiming points do not cause an excessively elevated line of fire. The RAU is to ensure all possible MPI fall within the bullet catcher. The worst-case practice, in terms of an elevated line of fire will be CQM LFMT 3m kneeling or squatting position.

6-13. **Target Spacing.** The number of targets per lane may be varied to meet training objectives but spacing should be:

- a. 2000mm minimum from the edge of the bullet catcher to the flank target centres.
- b. 1000mm minimum between target centres lane to lane.
- c. Targets in each lane should be at least 375mm apart.

6-14. Other layouts may be adopted for pistol practices, but sub-paragraph a. above remains the minimum.

6-15. **Target Mechanisms and Screens.** On older ranges a hand operated, turning target mechanism may be present. This turning target mechanism is part of the original design, which has been accepted as suitable for use. As such, the wire cables and pulley wheels are acceptable though the supporting posts should not have any exposed metal fixings. The tensioners should be either behind the mini-mantlet or no further forwards than the front edge of the 20m firing point. On new ranges or when major refurbishment is undertaken, the range can be improved by installing electrically or pneumatically operated turning targets which are controlled from the firing point. Zeroing screens and Target screens may be used on this range, but Harmonisation screens are not to be used due to the maximum permitted target height.

Range Floor

6-16. **Configuration.** The range floor is flat and level. It is to be surfaced with a minimum of 150mm (S) of soil free from large stones (>30mm (S) in any dimension) and it must be firm, free draining and should be bound with grass or similar ground cover which is kept cut short. The ground is to be assessed for the potential of arisings and where necessary measures to prevent stone from coming to the surface are to be taken. An example of such measures could be to install a membrane. Any paths provided are to be constructed of ricochet free material.

6-17. **Range Side Walls.** The design provides for the addition of concrete side walls to the range. These are not essential beyond 11m but may be built if it is considered expedient to raise the confidence of people near the range, or to eliminate distractions to the firers.

6-18. **Fences, Signs and Flags / Lights.** All access to the range when in use must be controlled. The standard range is enclosed with access for users at the rear of the range and vehicular access provided for range maintenance. Ranges that are in open access

areas, particularly those where woods or shrubs come close to the stop butt or side of the range should be fenced and signed to ensure access during firing is controlled. The same measures will be necessary where ranges with sloping earth bunds protect the sides of the range. Risk assessments will identify areas where access will need to be controlled. Where fences are deemed to be necessary prohibition signs will also be required. A flagpole for a red range in use flag is provided where it can best be seen. If night firing is to be conducted, a red light is fitted to the flagpole. If the flagpole is on the stop butt wall, any fixings or mounting attachments should be on the rear or top of the wall and not on the side facing the firers.

Firing Points

6-19. **25m Firing Point.** The 25m firing point crest is 450mm (T) above the range floor to create a near-level LoS from the prone position. All firing postures may be adopted. The surface may be of any low maintenance material fit for purpose.

6-20. **Other Firing Positions.** The 10m, 15m and 20m firing points are for weapons fired from the standing or kneeling positions only. These firing points are not normally specially surfaced but a prepared, non-backsplash or ricochet inducing, surface may be constructed to ease maintenance.

6-21. **Distance and Lane Markers.** Markers, constructed from non-backsplash inducing materials, should be suitably positioned to show distances and lane numbers on all firing points.

6-22. **Access to Bullet Catcher.** To ease maintenance, access to the bullet catcher through the side wall may be required. Should this option be incorporated, access doors will need to meet the centre fire rifle criteria for resistance to penetration in Chapter 2 if the access is within the 11mm return wall. Enhancement to the ground in front of the target will be necessary if vehicles are intended to use this access. Plastic grid sections are suitable "soft" track solutions.

Lighting

6-23. The range may be provided with lighting for night practices, but it is not designed for low light or LNV shooting. Where required the range is to be suitably illuminated to permit adequate visibility.

Communications

6-24. A means of summoning the emergency services, ideally a land laid telephone is to be available.

Maintenance

6-25. **Responsibilities.** A high standard of maintenance is essential to the safety of an NDA range. Responsibilities may be divided as follows:

- a. **Range Warden.** See DSA 03.OME Part 3 Volume 1 Part 2.
- b. **Property Management.** General inspection with particular emphasis on:
 - (1) Cladded structures.
 - (2) Fire trenches.

(3) Fences and signposts (see Chapter 2).

c. **Equipment Management.** Repairing and servicing equipment installed by Single Service Contract.

6-26. **Frequency.** Proper maintenance is dependent upon good liaison between the Range Warden and the RAU, and on properly scheduled maintenance periods. A heavily used range may need one day's maintenance each week plus one- or two-days' maintenance by the Range Warden each month. Two closed periods of a week or so may be needed each year for building and earthworks repair; this work should be combined with the contract repair of equipment.

6-27. **Bullet Catcher.** The requirements for maintaining the bullet catcher and de-leading are given in Chapter 2.

6-28. **Stop Butt Wall.** The possibility of hidden attrition behind the timber cladding is to be considered in the inspection programme. Repairs should be undertaken when bullet strike erodes more than 10% into the back wall. Repair should be undertaken with epoxy fillers on concrete or with materials of similar strength to the eroded material where other materials are used.

6-29. **Inspections.** DSA 03.OME Part 3 Volume 1 Part 2 defines the inspections to be carried out. On this range particular care must be paid to the high walls and vertical canopy.

Previous Version

6-30. Before the current version of the 25m Barrack range was introduced there was a design shown in Fig 6 - 5. The main differences between the two designs are the shape of the wing walls and that instead of a timber dropdown the timber cladding is fixed to the rear of the bullet catcher chamber. This design has been assessed by the Ordnance Board, reference D/OD/332/4/2 dated 25 Apr 83 and thus a range built to this standard is compliant.

Compliance Checks

6-31. The compliance checks to be carried out are detailed below:

- a. Authorised weapons, ammunition, and practices.
- b. Constructed in accordance with the ballistic elements described in this chapter.
- c. Where pre-cast sections are used, provision is to be made to avoid straight joints in ballistic elements.
- d. If not constructed to the current Standard Barrack Range, then it is to be in accordance with the compliance checklist for an Open Non-Standard NDA Range.

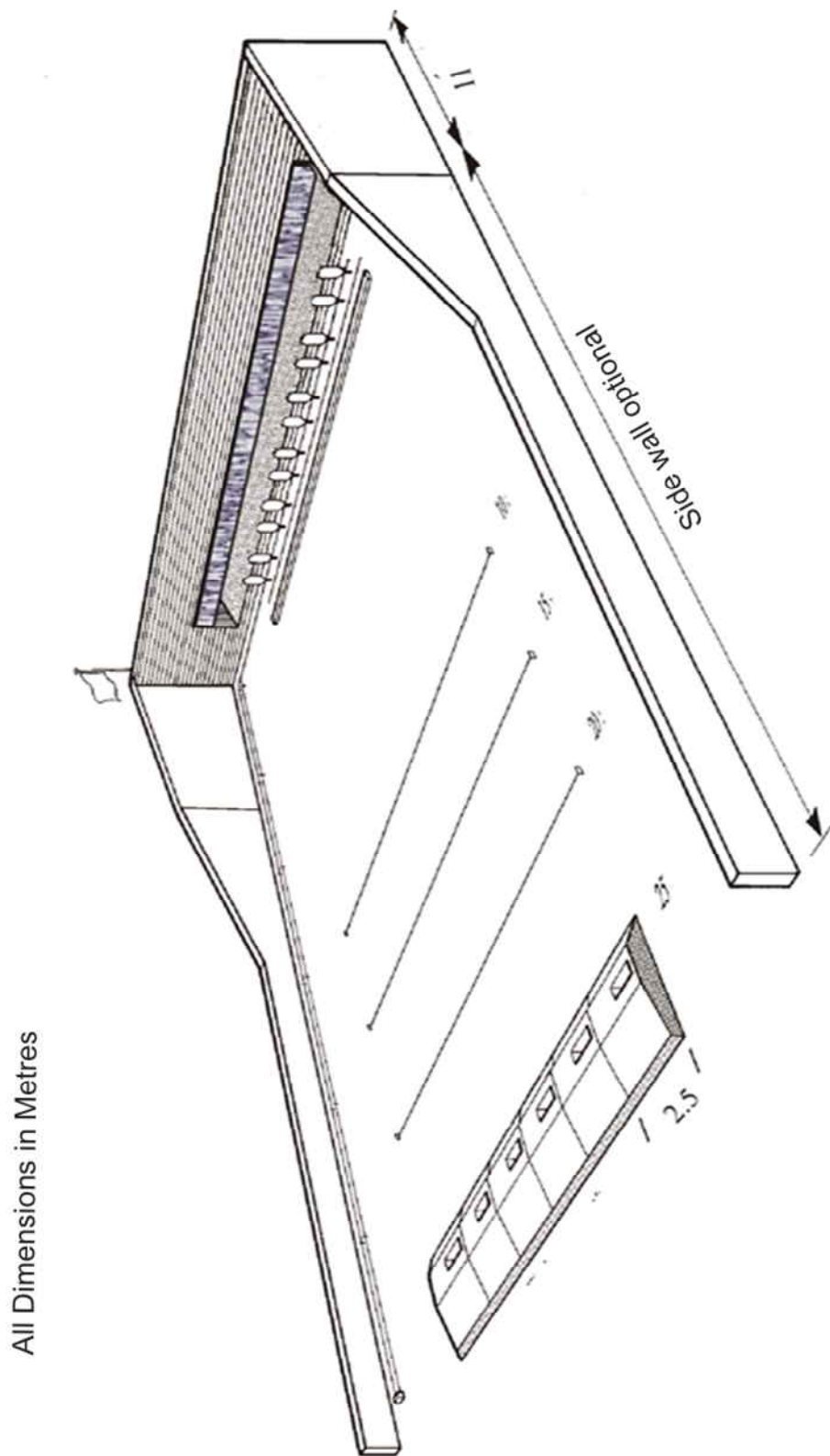

Fig 6 - 1. Typical Layout 25 Metre Barrack Range

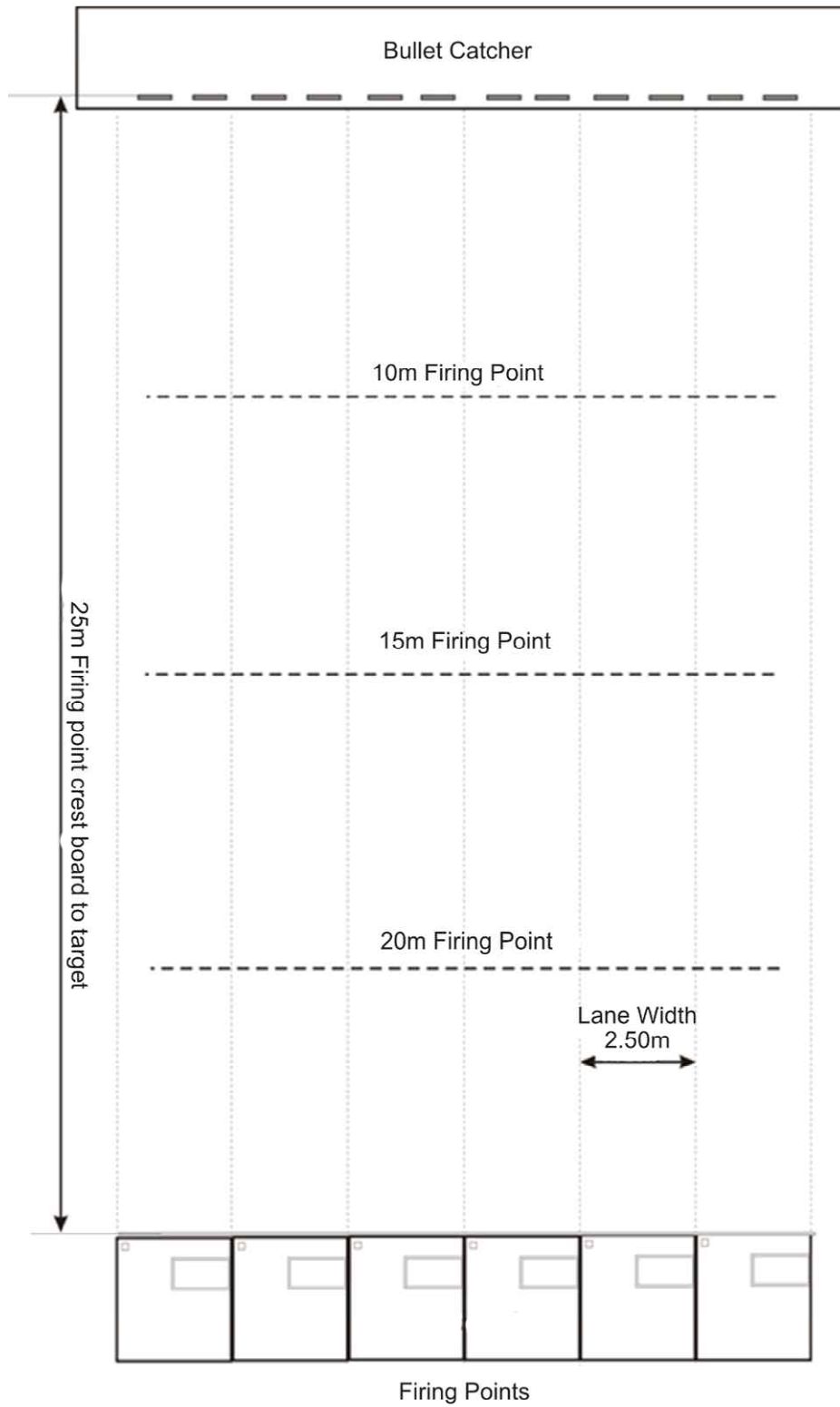

Fig 6 - 2. Range Floor Layout

Note: All dimensions are in millimetres, are standard and may change dependant upon the number of firing lanes. Dimensions with (C) indicate minimum dimensions for compliance.

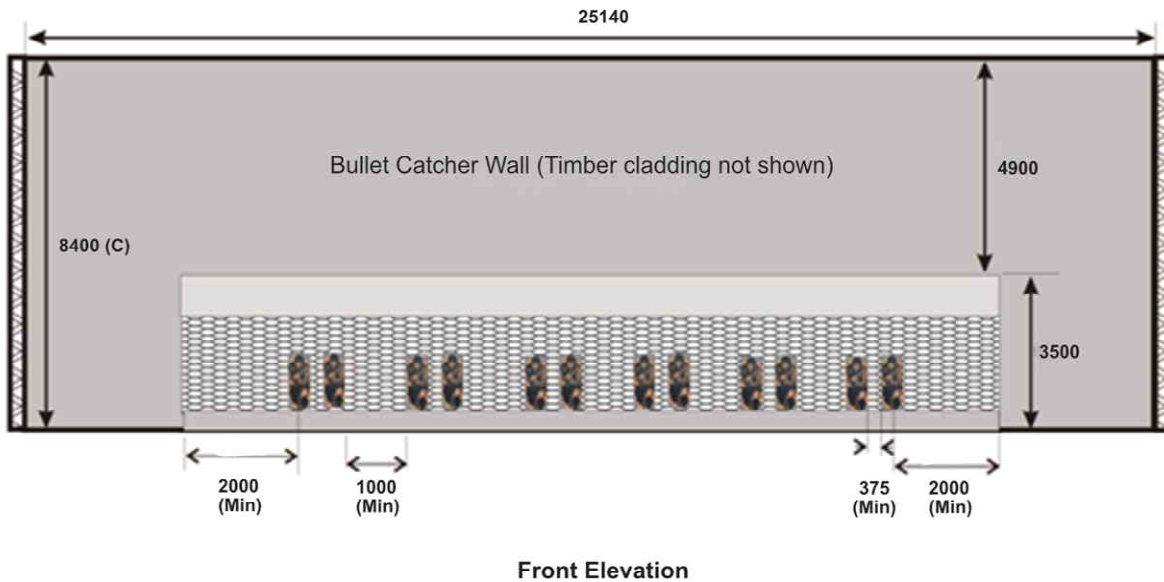
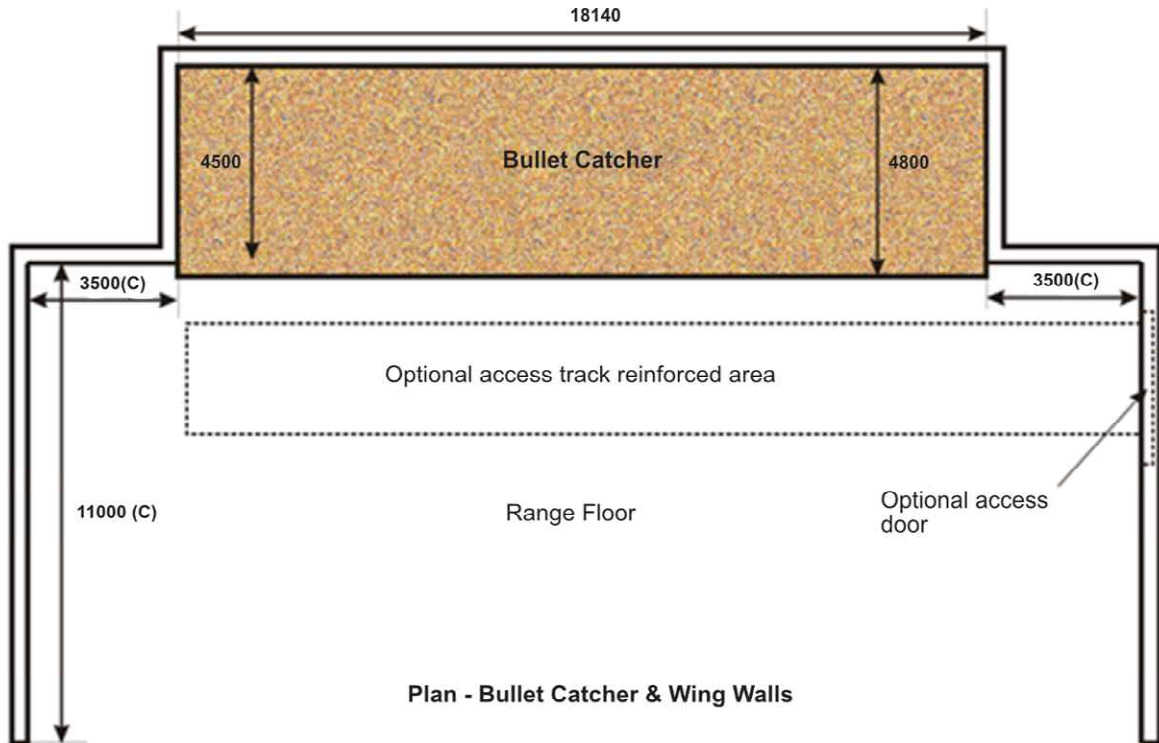

Fig 6 - 3. General Layout – Bullet Catcher

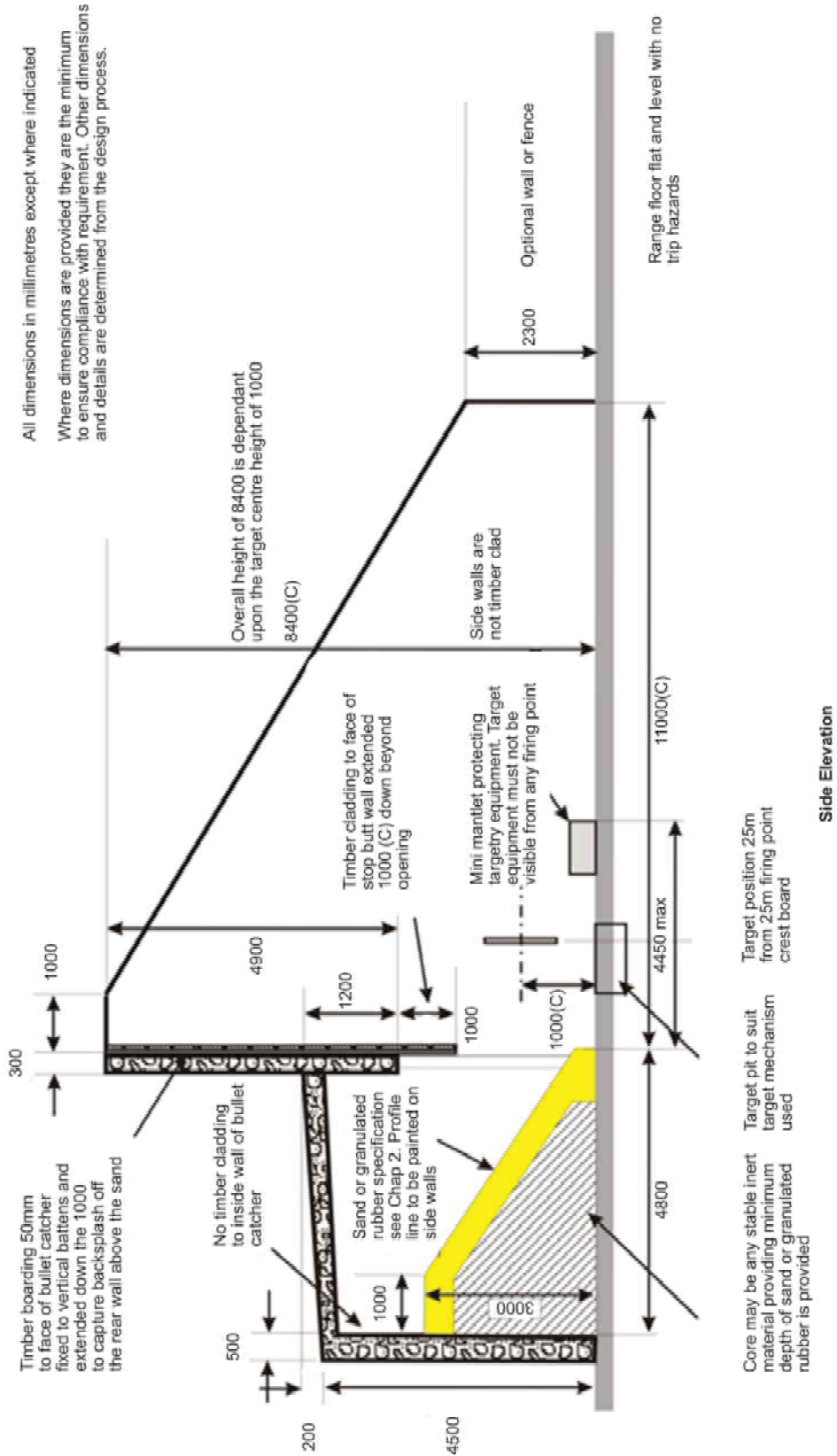

Fig 6 - 4. Detail at Bullet Catcher

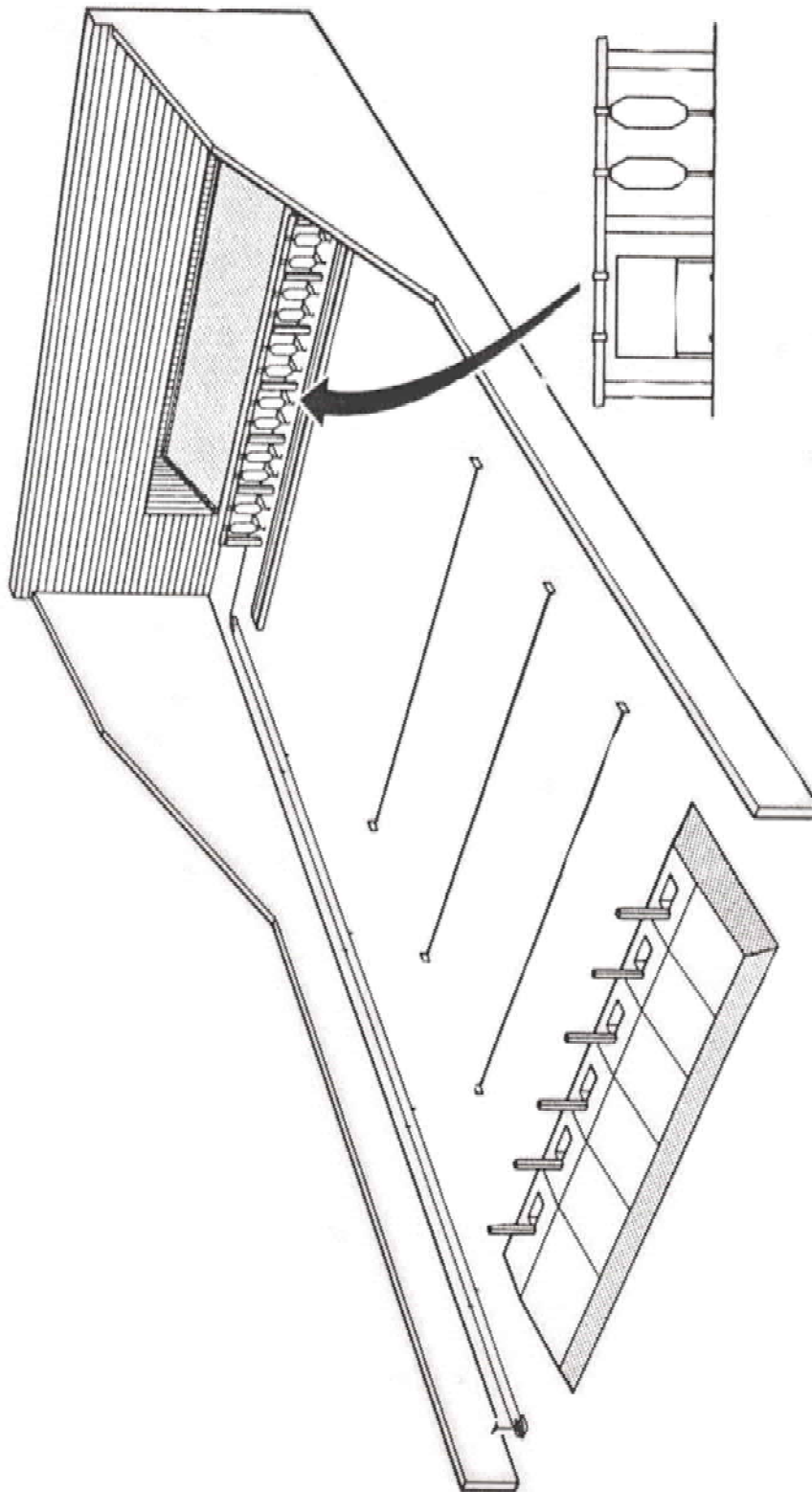

Fig 6 - 5. Layout Old Style Barrack Range

Chapter 7 - The 1908 Design Barrack Range

The 30yard Barrack Range with a ricochet pit, 6ft (1.8m) deep at the target line, is one of two designs approved by War Office Instructions for The Care and Construction of Rifle Ranges 1908. Many of these NDA ranges built in barracks and garrisons are still in use today, **however the 30yd firing point is no longer to be used**. The range has been converted to have four firing points at 25m, 20m, 15m and 10m. This Chapter is for range managers and inspectors only as all new barrack ranges are to be constructed in accordance with Chapter 6.

Major refurbishments or alterations to this style of range are to be to Non-Standard No Danger Area Range criteria, see Chapter 4. Only where the range meets in full the 1908 Design, or requires small changes, may this criterion be used. Refer to RITT for what is deemed to be small changes.



7-01. **Description.** Many ranges, whilst outwardly appearing to be 1908 Design ranges, are do not fit the standard design and hence should be assessed against Non-Standard No Danger Area criteria. All these ranges should now have been metricated for use as a 25m range. Modifications from the original design are described at paragraph 7-04 and the modified range is illustrated in Fig 7 - 1.

7-02. **Purpose.** This barrack range provides a local facility for limited firing practices up to 25m. It is not suitable for; any practices involving the use of CQM targetry, any practices closer than 10m with low velocity weapon systems, or any practices closer that 25m with high velocity weapon systems.

Design

7-03. **General.** The design of this range has evolved over time and has proven since 1908 to provide a safe environment in which to undertake shooting practices within a barrack area.

7-04. **Modifications.** The following modifications were added to the original design of this range:

- a. **Canopy.** A canopy has been added to the bullet catcher to contain 'pop-over'. There is the tendency for the occasional high velocity round to deform and ricochet at high angles out of the sand bullet catcher. The canopy roof is to be constructed to prevent rounds passing through it. The 5mm steel plate fixed to the underside of a timber canopy provides protection for at least $\frac{1}{2}$ the depth of sand and covering the full canopy width. Other impenetrable material, such as concrete, is also suitable. The standard design for fixing the steel has a weakness where the screws can fail and cause the steel to collapse. Regular inspection and maintenance should prevent this, though if required an approved method of fixing can be attained from RITT.
- b. **30yd Firing Point.** The range has been metricated with the addition of a 25m firing point. Where the 30yd firing point still exists it is not to be used.
- c. **Bullet Catcher Back Wall.** Inside the canopy a render coat of 1:4 cement / sand is applied to observe attrition and ease maintenance. See paragraph 7-26.

7-05. **Back-to-Back Ranges.** Some ranges were built back-to-back with the one stop butt wall. The wing walls had to be straight, and their length increased to 5.1m. For simultaneous use, canopies have been placed over the bullet catchers. A typical layout is shown in Fig 7 - 2.

7-06. **SA Limitations.** Limitations on the maximum number of SA, ammunition and rates of fire that can be used on this range are given in Pamphlet 21. These limitations give either an increased safety factor under difficult conditions or acknowledge that the design only caters for some practices and for stable aimed firing.

7-07. **Shot Guns.** The range design is suitable for shot guns firing solid slug or buck shot. Where ranges have significant solid slug practices de-leading frequency may need to be increased to avoid the build-up of lead at the MPI.

7-08. **Mantlets.** Some ranges have stepped mantlets to facilitate the use of harmonisation targets, which are normally inserted into slots in the face of the mantlet, however these are not mandatory.

Construction

Target Area

7-09. **Stop Butt Wall.**

- a. **Layout.** The stop butt wall consists of a central section at 1600mils (90^0) to the LoF and two wing walls projected forward at 2844mils (160^0). The standard four lane range was designed with the central section 7.4m long. If additional firing lanes were required, this length was increased by 1.8m for each additional lane but the length of the wing walls did not have to be increased.
- b. **Materials.** The stop butt wall was normally constructed of solid (void free) Class B engineering brick with a minimum thickness of 225mm or with materials which gave a similar resistance to shot penetration. Inspectors should ensure the brick used on these ranges do not permit rounds to enter more than 10% of the back or wing wall structures. Where penetration is clearly greater than 10% from one strike refer to RITT.

- c. **Height.** A standard wall height of 7.865m applied with a flat range floor. The excavation of a ricochet pit will enable the height of the stop butt wall to be reduced at a ratio of 1:1 with a maximum reduction of 1.8m, giving a minimum wall height of 6.065m.
- d. **Compliance.** The above is only valid for ranges that comply in all respects to the Standard Detail shown in Fig 7 - 1. In all other cases compliance is checked against Chapter 4.

7-10. **Canopy.** Where a canopy does not exist a Limited Danger Area (LDA) is required to fire high velocity ammunition. The LDA must extend laterally 100m from each flank target, striking an arc to a line 100m behind the stop butt to capture predicted pop-over. Without a canopy the range is classed as LDA (see Chapter 2). The facing edges of the canopy wing walls are to be protected with timber to prevent backsplash.

7-11. **Targets.** The range may be used with most in-service figure and screen targets, including harmonisation, for SA (see Chapter 24). It is essential to the safety of this range that the target centre design height is maintained. Care is necessary when mounting harmonisation screens which must be in sockets set lower down the mantlet. CQM is prohibited on this type of range and hence no CQM targetry is to be used.

7-12. **Turning Target Mechanisms.** The cable pull turning target mechanism originally provided on these ranges is difficult to operate and maintain. Two alternatives are available:

- a. **Capstan Operated.** See Chapter 24.
- b. **Electrically Operated.** These are described in Chapter 24. They may be permanently fitted and operated through a transformer to reduce mains electricity to 12 volts. Portable mechanisms require 12volt batteries. Electrically, rather than capstan, operated is the system of choice as it is cheaper to buy and to install. Its speed and simplicity of operation improves the training value of the range.

7-13. **Target Positions.** The number of targets per lane may be varied to meet training objectives but spacing should be:

- a. 1650mm minimum from the inside edge of the bullet catcher to the flank target centres.
- b. 600mm minimum between target centres lane to lane.
- c. Targets in each lane should be at least 375mm apart.
- d. Target centre height on this range is fixed at 875mm (C).

7-14. Other layouts may be adopted for pistol practices, but sub-paragraph a. above remains the minimum.

Range Floor

7-15. **Ricochet Pit.** The excavation of a 1.8m ricochet pit allowed the height of the stop butt wall to be reduced. This was justified by the effect which the pit has in:

- a. Reducing the number of ricochets from ground strike.

- b. Reducing the angle of strike and thus lowering the angle of ricochet.
- c. Moving the point of strike further down-range to help ricochet containment.

7-16. **Configuration.** The range floor is surfaced with a minimum of 150mm (S) of soil free from large stones (> 30mm (S) in any dimension). It is to be firm, free draining and should be bound with grass or similar ground cover which is kept cut short. Any paths constructed are to be of non-ricochet inducing material.

7-17. **Side Walls and Banks.** With proper range discipline and preparatory training, no hazard is predicted beyond the range floor. However, if it is necessary to increase the confidence of people adjacent to the range, a solid or screen wall may be provided. Earth banks may be used to screen a range provided the toe of the bank is beyond the range floor; otherwise, a round striking its sloped surface may leave the range.

7-18. **Fences, Signs and Flags / Lights.** All access to the range when in use must be controlled. Ranges that are in open access areas, particularly those where woods or shrubs come close to the stop butt or side of the range should be fenced and signed to ensure access during firing is controlled. The same measures will be necessary where ranges with sloping earth bunds protect the sides of the range. Risk assessments will identify areas where access will need to be controlled. Where fences are deemed to be necessary prohibition signs will also be required. A flagpole for a red range in use flag is to be provided where it can best be seen. If night firing is to be conducted, a red light is fitted to the flagpole. If the flagpole is on the stop butt wall, any fixings or mounting attachments should be on the rear or top of the wall and not on the side facing the firers.

Firing Points

7-19. **25m Firing Points.** The 25m firing point is raised to 450mm above ground level at the target line to ensure a depressed LoS from the prone position. It should also have a low maintenance surface that encourages the firer to take up a comfortable fire position.

7-20. **Other Firing Points.** The 20m, 15m and 10m firing points are for firing pistol from the standing and kneeling positions only. These firing points are not normally specially surfaced.

7-21. **Distance and Lane Markers.** Markers, typically constructed from timber, are to be suitably positioned to show firing distances and lane numbers on the firing points.

Lighting

7-22. The range may be provided with lighting for night practices, but it was not designed for low light or LNV shooting. Where required the range is to be suitably illuminated to permit adequate visibility.

Communications

7-23. A means of summoning the emergency services, ideally a land laid telephone is to be available.

Maintenance

7-24. **General.** It is essential to the safety of the range that the ricochet pit is maintained to its correct profile, depth, and width. The bank which forms a mantlet at the end of the pit

must be maintained at 600mils (34⁰) or greater. The pit should be well drained but a shallow collection of water at the very bottom of the pit is often unavoidable. However, a build-up of sediment in the drainage area must be avoided as it will eventually reduce the depth of the pit.

- a. **Warden.** See DSA 03.OME Part 3 Volume 1 Part 2.
- b. **Property Management.** General inspection with particular emphasis on:
 - (1) Stop butt, canopy, and wing walls.
 - (2) Fire trenches.
 - (3) Fences and signposts (See Chapter 2).
- c. **Equipment Management.** Repairing and servicing equipment installed by Single Service Contract.

7-25. **Frequency.** Proper maintenance is dependent upon good liaison between the Range Warden and the RAU, and on properly scheduled maintenance periods. A heavily used range may need one day's maintenance each week plus one- or two-days' maintenance by the Range Warden each month. Two closed periods of a week or so may be needed each year for building and earthworks repair; this work should be combined with the contract repair of equipment.

7-26. **Stop Butt Wall and Bullet Catcher.** Bullet strike on the stop butt wall above or beside the bullet catcher are to be recorded in the Range Log (MOD Form 906 series). If such incidents occur frequently, the range configuration may need to be checked by RITT. Where strike occurs shot marks should be made good and to ease inspection, the wall should be painted with an external sand or white paint. The bullet catcher back wall above the sand should be covered with a weak 12mm (T) thick render mix of 1:4 Cement / sand to ease repairs. The requirements for maintaining the bullet catcher, which may be either sand or granulated rubber, are given in Chapter 2.

Compliance Checks

7-27. The compliance checks to be carried out are detailed below:

- a. Authorised weapons, ammunition, and practices.
- b. Constructed in accordance with the ballistic elements described in this chapter.
- c. Where pre-cast sections are used, provision is to be made to avoid straight joints in ballistic elements.
- d. Method of fixing steel plate to underside of canopy
- e. If not constructed to the current Standard Barrack Range, then it is to be in accordance with the compliance checklist for an Open Non-Standard NDA Range.

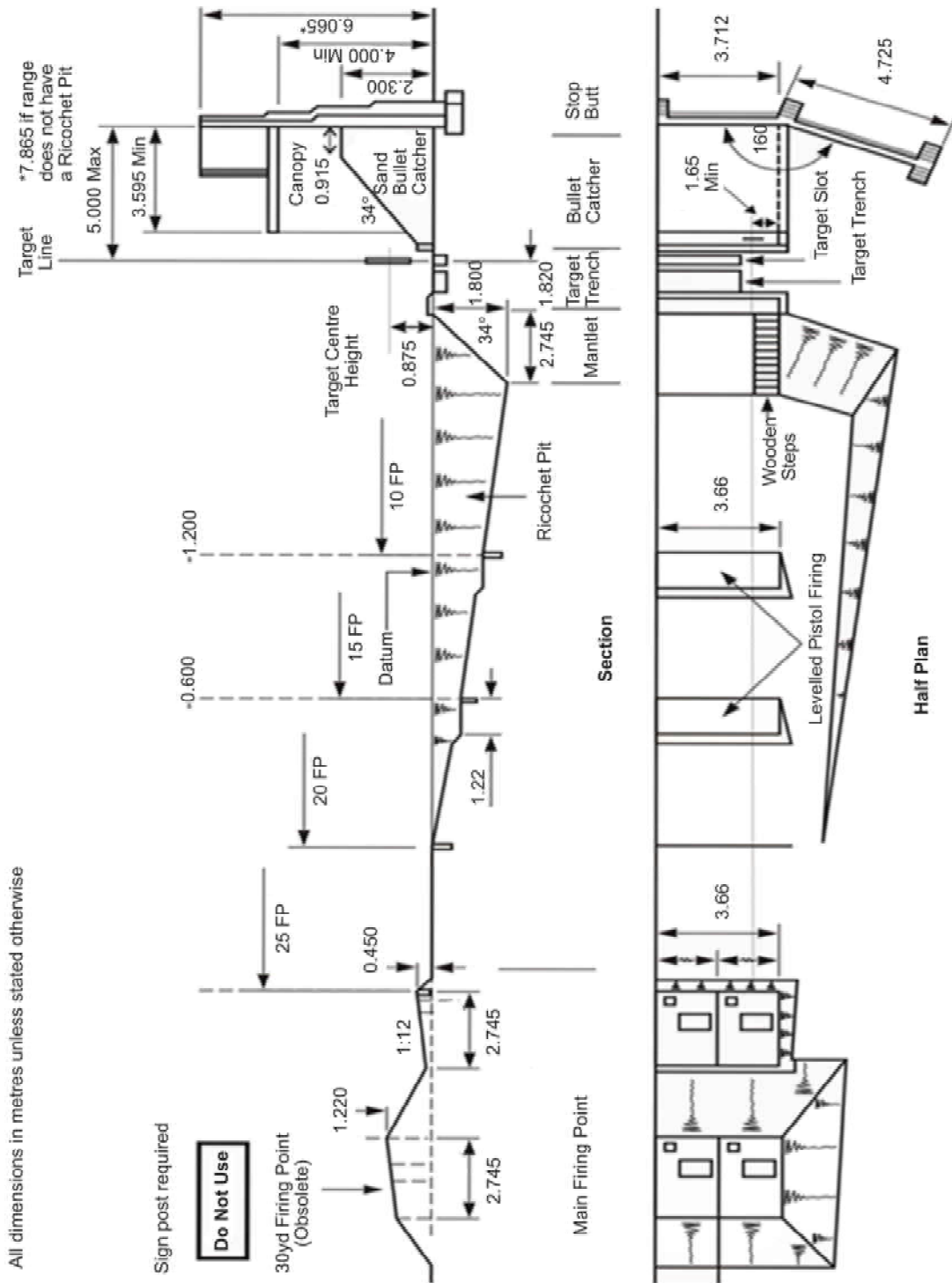

Fig 7 - 1. 30 Yard Barrack Range with Ricochet Pit

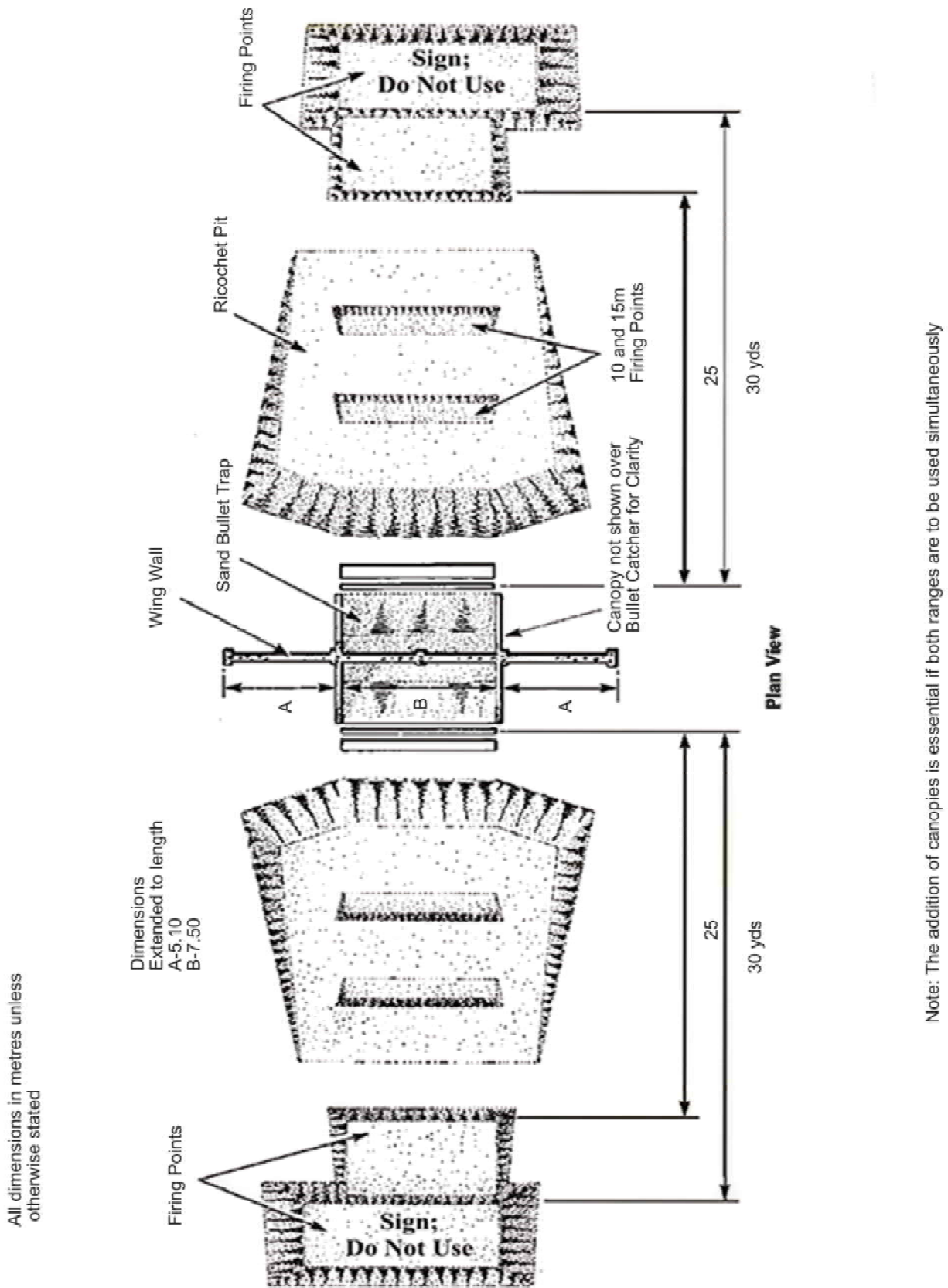

Fig 7 - 2. Back-to-Back Barrack Ranges

Chapter 8 - Tube Ranges

The tube range was originally known as an improvised range that was developed for use with rimfire SA and later for centrefire SA. The concept is a truly NDA range that suits those who need to minimise external noise levels. The aim of this chapter is to describe the design and construction of the tube range.



8-01. **Description.** These ranges are usually constructed using pre-cast concrete units, although any suitable tube or box section that will contain shot may be used. There is a firing house at one end and may have intermediate firing / target distances. At the target end the target house contains the bullet catcher and targets. The range may be surface laid, half or fully buried. It may be covered with topsoil to enhance the ballistic safety and is normally covered with turf for aesthetic reasons. In some cases, the firing point and target area are not fully enclosed. This range may be used for centrefire and rimfire weapons limited only by the ballistic criteria for backsplash, ricochet and penetration detailed in Chapter 2. Only one firer can use a tube however there may be multiple tubes allowing several firers to use the range simultaneously provided the minimum firing point widths given in Table 8-1 are adhered to.

8-02. **Purpose.** This range provides a local facility for limited for single shot firing practices and the range may be suitable (dependent upon the diameter of the tube) for conducting pistol ACMT, introduction to shooting, remedial training, preliminary grouping and zeroing, and training sub-unit shooting coaches. It is also an ideal solution for zeroing ranges within secure operational bases. See paragraph 8-40 onwards.

Design

8-03. **Design Criteria.** Illustrations of a typical range are shown in Fig 8 - 1 for a centrefire range and in Fig 8 - 2 for a rimfire range. Fig 11 - 3 shows the application of bullet catcher and defence zone criteria, which applies to both rimfire and centrefire ranges. Considerable variation in the design is possible, with consultation from RITT. The principle of this range is that the tube will fully contain the shot fired in it. Whilst it is a simple matter to arrange the weapon to be within the tube, the safe capture of the shot and ricochet poses the biggest design problem. Environmental issues such as lead dust, unburnt propellant, carbon monoxide and noise must also be considered, refer to Chapter 25. Essential in the construction of new ranges is an internal finish specification that minimises the build-up of dust. In existing firing rooms and bullet catchers all non-essential dust collecting surfaces should be removed or sealed to prevent dust accumulating out of sight.

8-04. **Siting.** The range is intended for use in barracks or garrison areas, it is also suited for operational bases. It requires a flat and level site on firm, well drained land. The external considerations are lead dust from the extract filter, noise, and aesthetics.

Construction

8-05. **Bullet Catchers.** The bullet catcher is sized to capture all direct shot, as shown in Fig 8 - 3. The type of bullet catcher selected will depend principally upon the SA to be fired. These are:

a. **Rimfire and Centrefire Pistol / Carbine.**

(1) **Flat Steel Plate with Anti-Splash Curtain.** This is the simplest and cheapest form of bullet catcher. It does however create a lot of lead contamination in the target area and the anti-splash curtain requires maintenance. The steel plate is bolted back to a solid wall with a material sandwich between to reduce both impact and transmitted noise (see Chapter 3) and has sacrificial plates at the Mean Point of Impact (MPI). The thickness of steel is determined from Chapter 2 Table 2-7. Size will be dependent upon the distance from the end of the tube.

(2) **Angled Steel Plate with Anti-Splash Curtain.** Although this design is often selected by range builders, it offers no advantage over the flat steel plate and is often noisier. With both this and the flat steel plate, a sacrificial plate at the MPI will extend the life of the bullet catcher. However, for the angled steel plate care will be required not to expose its leading edges to the LoF.

(3) **Alternative Bullet Traps.** There are many designs commercially available, but most have safety shortcomings. Two bullet traps described below for Centrefire Rifle are also suitable for rimfire weapons, pistol, and carbine, though they will be more expensive than the traps above. These are the Snail Bullet Trap and the Granulated Rubber Trap.

b. **Centrefire Rifle and Automatic Fire.**

(1) **Sand Bullet Catcher.** Sand bullet catchers are not recommended indoors due to the dust hazard from the sand. For ranges where the bullet trap is not enclosed the traditional sand bullet catcher with canopy protection or limited danger area is acceptable. This latter option would be suitable for operational base tube ranges.

(2) **Angled Steel Plate with Anti-Splash Curtain.** This bullet catcher has been used on simple, low-cost centrefire tube ranges but it may only be used for firing single shot. High maintenance costs make this design a poor choice on a centrefire range which is to be heavily used. A full specification for steel is provided in Chapter 2.

(3) **Snail Bullet Trap.** This is a proprietary bullet decelerator, patented by the Savage Arms Corporation of the USA, reduces lead pollution problems at the target end of the range, can be used for automatic fire and it can be produced to accept the 0.5in round. It must however be individually designed for each range by the supplier to ensure that military safety criteria are met. This type of trap is

unsuitable for steel or steel tipped rounds. Snail traps cannot be locally manufactured due to precise impact surface design.

(4) **Granulated Rubber Trap.** The granulated rubber trap used at a natural angle of repose potentially is a very cost effective and environmentally friendly solution. Details of this trap are provided in Chapter 2, and it is illustrated at Fig 3 - 7.

8-06. **Defence Zone.** The Defence Zone (DZ) is intended to be impenetrable to shot and is to contain ricochet beyond the bullet catcher. It is sized as shown in Fig 8 - 3. Any portion of the target house within the defence zone is to have a minimum construction as detailed in Table 7, Chapter 2 or be over-plated with steel as specified Table 2-7a, Chapter 2. Defence Zone criteria also applies where there are trap doors above the target end of the range.

8-07. **Targetry Selection.** When selecting targets and target mechanisms, the difficulty of moving down the range to mark or change targets should be borne in mind if target retrieval systems are not installed in the tube. An automatic marking system and a simple turning target mechanism will greatly enhance the range and the training value. Fall-when-hit systems are difficult on a tube range as the concentration of the sound energy in the tube may activate the mechanism without the target being struck. Representative targets sized to give the appearance of targets at greater ranges (see Chapter 24) provide valuable training on shorter ranges. The tube range lends itself to competition shooting. To minimise the risk of ricochet off the tube walls, targets should be presented centrally in the tube.

8-08. **Ricochet and Backsplash.** There should be nothing within the backslash zone (see Table 2, Chapter 2) that could cause ricochet or backslash. Any services, ducts or parts of the target mechanism that can be struck are to be protected. Should falling plate or other impenetrable target be used the distance from the target to the firing point must be greater than the hard target backslash distance (see column c, Table 2-2, Chapter 2) and the effects of subsequent ricochet on services and fittings in the target house must be considered.

8-09. **Target Illumination.** Target illumination is ideally achieved with a single 5ft fluorescent strip light per target which may be mounted above or below the target or to the sides between each tube. Reflector lamps of 100 watt per target may be used if dimming is required for low light level shooting.

Tube

8-10. **Size.** The diameter (dia) of the tube should be selected to suit the targetry and practices. The size selected must allow a clear view of the whole target but is not to be less than:

- a. Ranges up to 25m: 900mm dia to allow for access. For existing ranges tubes of less than 900mm dia, special provision for cleaning will be required due to the potential for the tube being classed as a confined space.
- b. Ranges greater than 25m: 1800mm dia is desirable but the minimum size is 1200mm, which is also the minimum size to accommodate the Fig 11 target.

8-11. **Laying.** A reinforced concrete pipe with a wall thickness of not less than 75mm, of the type typically used for drainage works, is normally selected to form the firing tube. Particular attention shall be paid to the bedding of tube sections to ensure future settlement or movement is eliminated as any such settlement will render the range unsafe. The tube must be laid straight to line and level. The laying tolerance is plus or minus 50mm over a 100m length. No edges or lips may occur which would cause backsplash if struck and any of 3mm or more facing the firer must be ground off or feathered out. To avoid problems with settlement of the sectional tube components a flexible continuous liner may be inserted into the tube. The tube may be completely or partially below ground or may be laid at ground level and banked over. The tube should support its own dead loads, and all the loads imposed upon it. Tubes without a liner should:

- a. Be bedded and supported to eliminate any subsequent settlement that will generate backsplash hazards from misaligned joints.
- b. Have the socket end of the pipe facing the firer.
- c. Have all joints sealed watertight and the tube coated with a waterproof membrane.

8-12. **Earth Cover.** Earth cover to the tube will vary depending on the type of tube range. An additional allowance must be made for landscaping such that over the seasons soil erosion and ground maintenance works will not reduce the compacted earth cover to less than a minimum of 500mm for centrefire rifle ranges but for rimfire tube ranges no earth cover is required for ballistic purposes.

8-13. **Lighting.** Some form of lighting may be required according to the length of the tube.

8-14. **Weapon Muzzle Limit.** At each firing point a line that is clearly visible should be painted with the farthest edge 150mm (C) inside the tube to denote the point to which the muzzle should be inserted before engaging the target. This will preclude any chance of rounds striking the leading edge of the tube.

Firing Bay

8-15. **Firing Points.** Firing points should be constructed as per Chapter 3, ideally with the height such that the weapon is positioned centrally in the tube for all firing postures, although this is less important in large diameter tubes, i.e. over 1200mm. To cater for all three postures, platforms at two or three different levels may be required. Small diameter tubes are best limited to the prone position or prone and standing in a trench. The firing point widths given in Table 8-1 are the minimum widths required and to consider:

- a. Practices to be fired.
- b. The space required for coaching.
- c. Disturbance caused by adjacent weapon noise.
- d. The hazard caused by ejected cartridge cases.

8-16. **Screens.** Screens between firers can be used to reduce firing point width. The screen should be designed to reduce both noise transmission to adjacent firing points and

reflected noise (reverberation). Screens must not be so deep that they restrict the RCO's view of the firers. Table 8-1 is a guide to firing point widths on a multi-firing point range.

Table 8-1 - Minimum Firing Point Widths

(a) Minimum firing point width	(b)	(c)
	Width of each firing point (m) With screens	Width of each firing point (m) Without screens
Pistol	1	1.8
Rimfire Rifle	1	1
Centrefire Rifle	1.8	1.8
Automatic Fire	2.5	2.5

8-17. **Floor Finish.** The floor finish on the firing point must be smooth and impervious to facilitate the removal of lead dust and traces of unburnt propellant. A sealed, non-slip surface of rubber or PVC may be provided with a cushioned backing. Porous materials such as mats and sandbags, which can harbour lead or unburnt propellant, are not to be used in the range. A hard-smooth floor will reduce ricochet potential.

8-18. **Pistol Firing Points.** Care is required in the design of pistol firing points. It is possible for an unintentional shot to be fired at about 45° (800 mils) to the LoS and even withdrawn from the tube. Surfaces which capture or direct the round without ricochet or backsplash are essential.

8-19. **Intermediate Firing Distances.** Two options are possible to provide short firing distances for pistol practices on longer rifle ranges:

a. **Large Diameter Tubes.** If the tube diameter or section is 1750mm or larger, intermediate target positions can be provided within the tube which are engaged from the main firing point. The bottom of the tube can be levelled with a soft bitumen macadam so that firers can move down the tube to mark and change targets. Target mechanisms and edges within the tube are to be protected against backsplash (see paragraph 8-08).

b. **Small Diameter Tubes.** Tubes of less than 1750mm in diameter or section are regarded as too small for firers to walk down. Pistol firing points in this case are provided in firing rooms forward of the main firing point. The design must ensure that the RCO can maintain effective control. This is an expensive option as added requirements are:

- (1) Ventilation and noise attenuation in two locations.
- (2) Anti-ricochet and backsplash protection around the intermediate firing point.
- (3) Safety interlock and warning systems to ensure that more than one firing points cannot be entered at the same time.

8-20. **Firing Point Chamber.** The firing point chamber is to provide sufficient circulation space for firing details to change safely. On ranges with three or more firing points, separate entry and exit doors should give access to an assembly room behind. A walkway is needed behind the firing points for the RCO, and space should be provided on large ranges for a coach to assist the RCO. Open or partially enclosed firing rooms will reduce the impact of weapon emissions and noise, but it makes it difficult to control air flow in the tubes.

8-21. **Lighting.** Lighting levels are to be such that when exposed, the targets are clearly visible to the firers.

8-22. **Control, Waiting and Assembly Rooms.** If an AMS and turning targets are installed, a control room may be positioned behind the RCO's walkway. It should be a glazed sound-proofed booth. The waiting detail and assembly room are also to be isolated from the firing point noise and be provided with a glazed viewing panel.

Safety Measures

8-23. **Access.** As the RCO may be unable to observe outside the range, control measures are required to prevent access to the range when it is in use, and where doors cannot be secured, to activate audio and visual warnings and safety interlocks.

8-24. **Entrances.**

a. **Main.** A red lamp or sign is placed in a prominent position to warn that the range is in use.

b. **Other.** Doors that can be opened to the target house or to intermediate firing chambers are to cause target lights to be extinguished and to activate an audio and visual alarm in the main firing chamber. Provision is to be made to allow the RCO to reset the audio-visual alarm within the firing room. The alarm system is to have a device that indicates the alarm is correctly reset and is 'live'. Where all down range doors are fully secured by the RCO such measures are not required.

8-25. **Shields.** A safety shield is to be provided at the opening of the tube behind each intermediate firing chamber so that it can be raised to block off the tube behind it.

8-26. **Noise.** All new tube ranges should include noise control measures specifically designed for the range. Full details are given in Chapter 2. However, the following are pertinent to a tube range:

a. **Noise Containment.** This is effectively achieved by burying the tube under earth. If the target house and firing rooms are not buried, additional measures may be necessary (see Chapter 2).

b. **Noise Attenuation.** Noise in the tube can be severe if it is not effectively controlled. Careful thought is required to cover the tube's curved surfaces to provide the maximum Reverberation Time (RT), which should not exceed 0.5 sec at 500 and 1000 Hertz (Hz).

8-27. **Ventilation.** The requirements for ventilation in indoor training ranges are given in Chapter 25.

8-28. **Fire Hazard.** When specifying materials used in range construction, their fire rating must be considered. Materials such as rubber compounds and timber can present a fire hazard. This, combined with factors such as heat from target lighting and the presence of unburnt propellant, require that careful consideration is given at the design stage to fire prevention. Means of escape should conform fully to the regulations.

8-29. **Fire Approval.** Attention is drawn to Regulatory Reform (Fire Safety) Order for England and Wales; the Fire Safety (Scotland) Act and the Fire Safety (Scotland) Regulations, the Fire and Rescue Services (Northern Ireland) Order. The requirements include a general duty to carry out a risk assessment and take precautions against fire. Fire safety is also covered by the respective Building Regulations (England and Wales; Northern Ireland; Scotland). The advice and approval of DFR is mandatory on all new or reconstructed indoor ranges.

8-30. **Eye Protection.** In small tubes where there are rough joints in the tube walls or other backsplash obstructions in the tube these should be rectified wherever possible. In cases where this is not possible eye protection is to be worn by all firers. For current eye protection see Pamphlet 21.

Communications

8-31. **External.** A means of summoning the emergency services, ideally a land laid telephone is to be available.

8-32. **Internal.** A means of communication between the RCO and the waiting detail in the assembly room should be provided. On larger ranges and when there is a separate control room, a full Public Address (PA) system should be considered.

Safety Signs

8-33. **Safety Signs.** The risk assessment for the range will determine what safety signs are required. Details of the signs are illustrated in Chapter 2. In all cases the following signs should be provided, however other signs covered by SHEF may be required:

- a. No Smoking.
- b. No food or drink in the range.
- c. Keep out when range is in use.
- d. Hearing protection to be worn when firing.
- e. Wash Hands

Maintenance

8-34. **General.** Regular cleaning is essential to ensure that lead dust and unburnt propellant do not build up in the range. Cleaning requirements are given in Chapter 25. The target line must be kept clear of target debris. In some smaller ranges the target house may need to be considered a confined space and the appropriate control measures should be applied when accessing for maintenance. Advice from local works officers should be sought.

8-35. Bullet Catchers.

- a. **Steel Plate Bullet Catchers with Anti-Splash Curtain.** It is essential that this type of bullet catcher is regularly de-leaded. The anti-splash curtain is to be inspected before firing begins to ensure that it is not holed. To prevent holing, the curtain should be rotated regularly to ensure that the MPI location is moved. Holes can be repaired by patching with pieces of salvaged curtain using a suitable adhesive. There must be no more than two layers of anti-splash curtain at any point in the line of fire.
- b. **Sand Bullet Catchers.** See Chapter 2. In addition, the sand is to be kept moist to stop dust getting into the range.
- c. **Snail Bullet Trap.** It is necessary to keep the reservoir of the Snail Bullet Trap topped up with lubricating fluid and to ensure that the pump is running before firing starts. Spent rounds in the collection baskets must be emptied periodically.
- d. **Granulated Rubber Trap.** This trap requires little maintenance. The MPI should be prodded regularly to check for accumulation of rounds and to assist in round migration through the granulate. De-leading should be as detailed in Chapter 2.

8-36. Tube Settlement. Where concrete tube sections have settled causing a concrete lip to appear that may generate hard backsplash such lips are to be removed by grinding or treated to prevent backsplash. Use of epoxy mixes well bonded to the concrete surfaces and feathered out presenting a low angle slope to the firer should be sufficient to prevent backsplash.

8-37. Responsibilities. Maintenance is the responsibility of the RAU. Responsibilities may be divided as follows:

- a. **Range Warden.** DSA 03.OME Part 3 Volume 1 Part 2.
- b. **Property Management.** General inspection with particular emphasis on:
 - (1) The back wall especially the defence zone area.
 - (2) Tube alignment. Careful checks to ensure settlement of the tubes has not presented a hard backsplash hazard.
 - (3) Access security systems.
 - (4) The ventilation system (if fitted).
 - (5) Check for bullet damage to any electrical fittings.
- c. **Equipment Management.** Repairing and servicing equipment installed by single Service contract.

8-38. Frequency. Proper maintenance is dependent upon good liaison between the Range Warden and the RAU, and on properly scheduled maintenance periods. A heavily used range may need one day or more maintenance each week plus one- or two-day's maintenance by the Range Warden each month. For frequency of de-leading .22" ranges refer to Chapter 25, deep cleaning. Other trap systems may differ in frequency of maintenance and de-leading. For deep cleaning refer to Chapter 25.

Compliance Checks

8-39. The following should be checked:

- a. Authorised weapons, ammunition, and practices.
- b. Target House - Type of bullet catcher, bullet catcher sizing, defence zone sizing and structure, target material and fixing method, target centre height. Doors.
- c. Tube diameter, wall thickness, material, tolerance, and cover.
- d. Any protrusion in the tube greater than 3mm that might generate backsplash.
- e. Firing Bay - Firing point height, width and spacing and intermediate firing distances, if applicable.
- f. Signage and lighting.
- g. Noise control measures.
- h. Ventilation arrangements.

Operational Tube Ranges

8-40. **General.** The tube range has been known for many years as an improvised range. The concept suits those who need to develop semi-permanent NDA ranges in troop operational base areas. The range is suited for zeroing and grouping practices for small numbers only.

8-41. **Aim.** The aim of this advice is to describe the design and construction of an improvised tube range where it differs from the detail for PTR.

8-42. **Design Criteria.** Due to the temporary nature of these ranges foundations to avoid long term settlement of the tubes and the total enclosure of the range may not be necessary. Considerable variation to the basic design is possible with advice from RITT. The principle of this range is that the tube will fully contain shot fired within it even where the firing point and bullet trap is not fully enclosed. All range design proposals should be copied to RITT to ensure ballistic safety is achieved.

8-43. **Siting.** Temporary ranges are constructed in Operational bases. These ranges require a flat and level site on firm, well drained ground. With an open firing point, noise will be a consideration to avoid disturbing resting troops.

Construction

8-44. **Bullet Catchers.** The bullet catcher must stop both direct fire and ricochet. The bullet catcher for improvised ranges may be constructed of local material providing that it is free of stones or rock. There are two options suitable for improvised ranges.

- a. **Sandbag Wall / Bund.** This trap presents a steep (min 56°) or vertical sand or earth face from which ricochet is not likely. Ricochet off the tube towards the end is a factor that will dictate the height of the vertical face of the stop butt. Clearly the closer the stop butt to the target the better. A canopy may be used to reduce the need for a high stop butt. The problem with this trap is that the MPI will soon be shot out and require repair. A sacrificial front wall of sandbags will avoid the need to rebuild the

bund each time. Where steel mesh gabions are used sandbags should be used behind targets to avoid hard ricochet or backsplash (50m) with timber boarding over the remainder of steel exposed to the firer. For dimensions see Chapter 2.

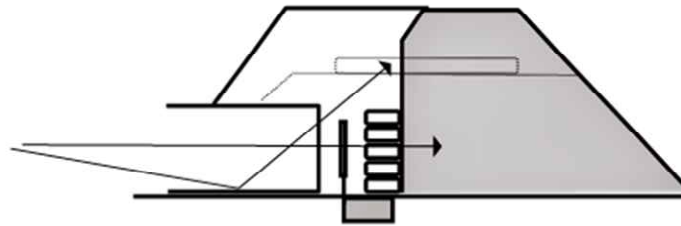

Fig 8 - 1 - Typical Bullet Trap Arrangement.

b. **Traditional Sand Bank with Canopy Or 100m Range Danger Area.** The traditional sand bullet catcher with a 900mm (C) depth of sand at 34° (600 mils) is a safe, reliable, and proven design. It is safe for automatic fire in short bursts. To capture high angle ricochet and 7.62mm pop over, a canopy of minimum 180mm thick timber (rail sleeper) or steel plate should cover the target area. If there is sufficient space, a 100m RDA may eliminate the requirement for a canopy.

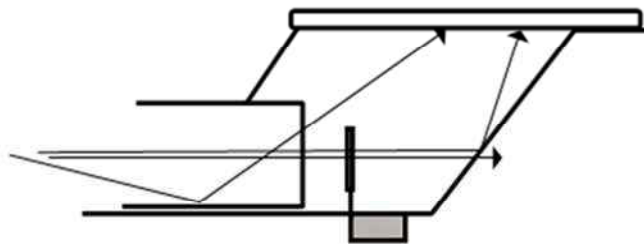

Fig 8 - 2 – Typical Bullet Trap Using Sand Natural Angle of Repose (30° – 34°).

8-45. **Target Selection.** When selecting targets and target mechanisms, the difficulty of moving down the range to mark or change targets should be borne in mind as target retrieval systems cannot easily be installed in the tube. An automatic marking system and a simple turning target mechanism will greatly enhance the range and the training value. Fall-when-hit systems are difficult on a tube range as the concentration of the sound energy in the tube may activate the mechanism without the target being struck. The Fig 11 remains the target of choice for military practices but requires a large diameter tube. Representative targets sized to give the appearance of targets at greater ranges provide valuable training on shorter ranges. To minimise the risk of ricochet off the tube walls, targets must be presented centrally in the tube. Multi-point targets should not be used unless the range has been specifically designed for this type of target.

8-46. **Ricochet and Backsplash.** Refer to paragraph 8-08.

8-47. **Target Illumination.** Refer to paragraph 8-09.

8-48. **Firing Points.** Refer to paragraph 8-15.

8-49. **Pistol Firing Points.** Refer to paragraph 8-18.

8-50. **Intermediate Firing Distances.** Refer to paragraph 8-19.

Safety Measures

8-51. **Access.** The RCO must be able to observe the bullet trap area and RDA where an RDA is provided but not secured.

8-52. **Range in Use Warning.** A red flag is placed outside the main access point to the range to warn that the range is in use.

Communications

8-53. A means of summoning the emergency services, ideally a land laid telephone is to be available.

Maintenance

8-54. **General.** Regular cleaning is essential to ensure that lead dust and unburnt propellant do not build up in the range. The target line must be kept clear of target debris.

8-55. **Bullet Catchers.**

a. **Sandbag Bullet Catchers.** Ballistic slopes must be maintained at 56° or greater and stone free. The depth of sand visible from the tube must never be less than 900mm (C).

b. **Sand Bullet Catchers.** The sand must be maintained at an average of 34° (S), never less than 30° (C) in use. The depth of sand visible from the tube must never be less than 900mm (C). The canopy roof must be monitored to ensure rounds do not escape.

8-56. **The Tube.** Regular checks inside the tube are required to ensure there is no backsplash hazard from differential settlement of the tube sections.

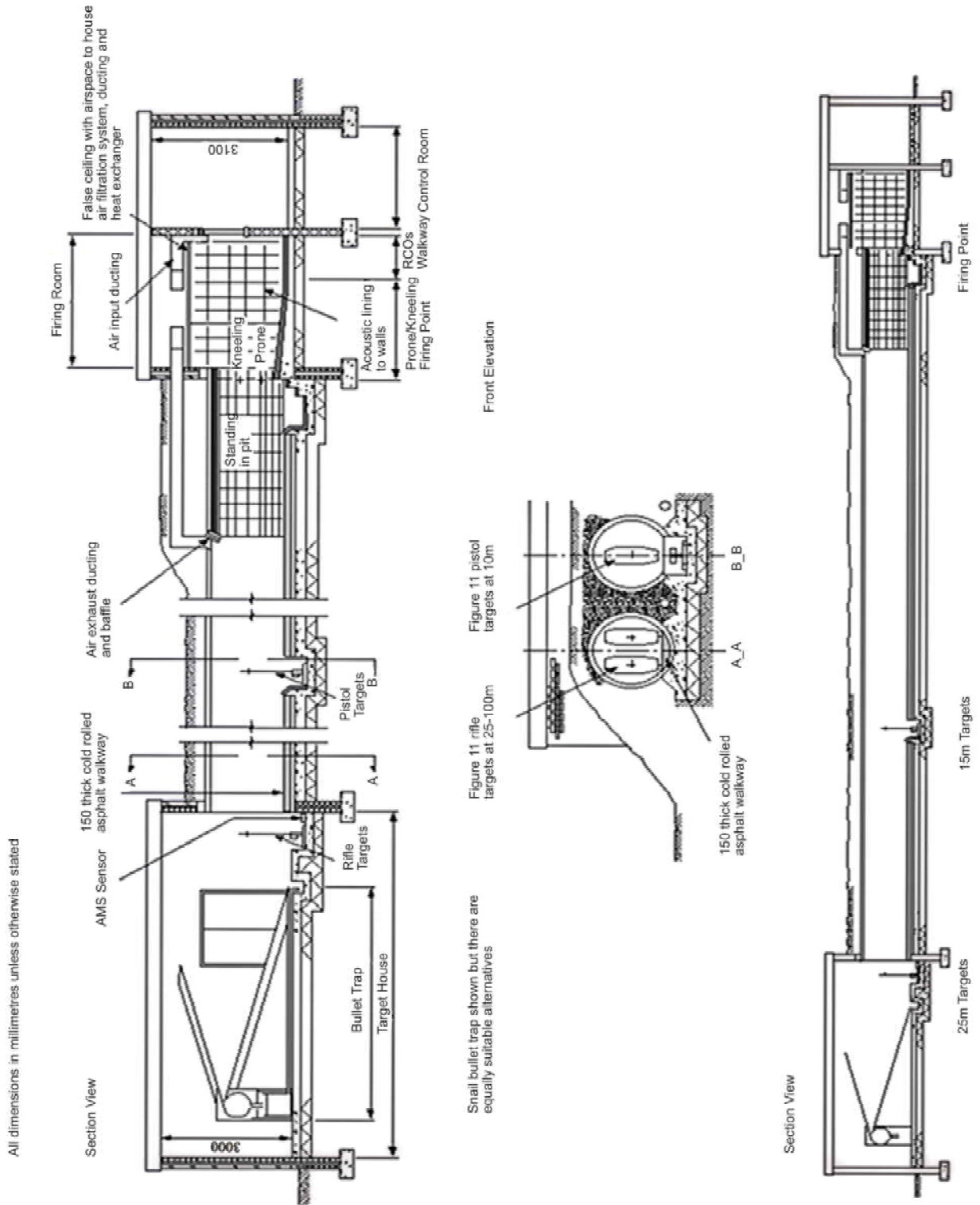

Fig 8 - 3. Typical Centrefire Tube Range Layout

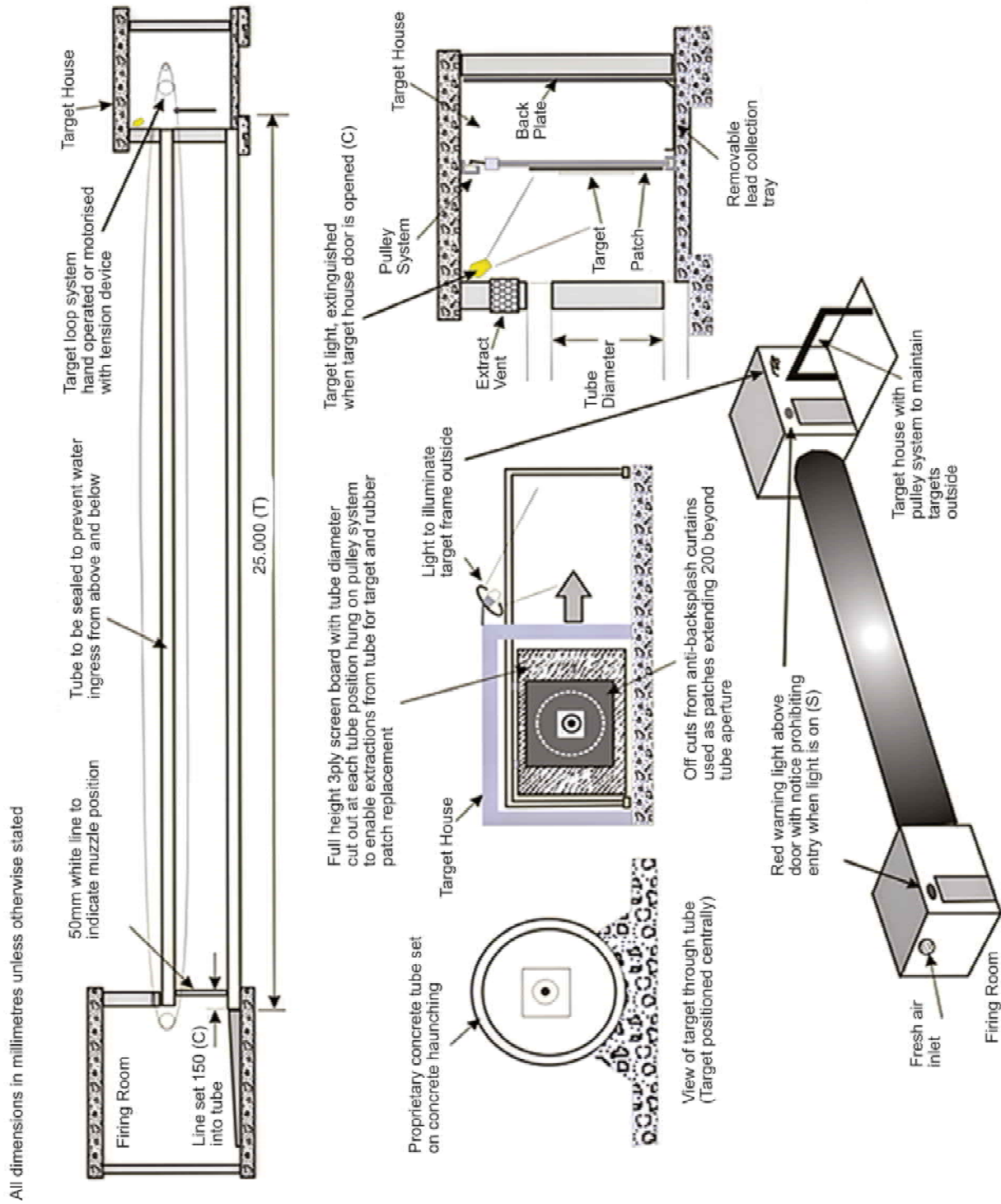
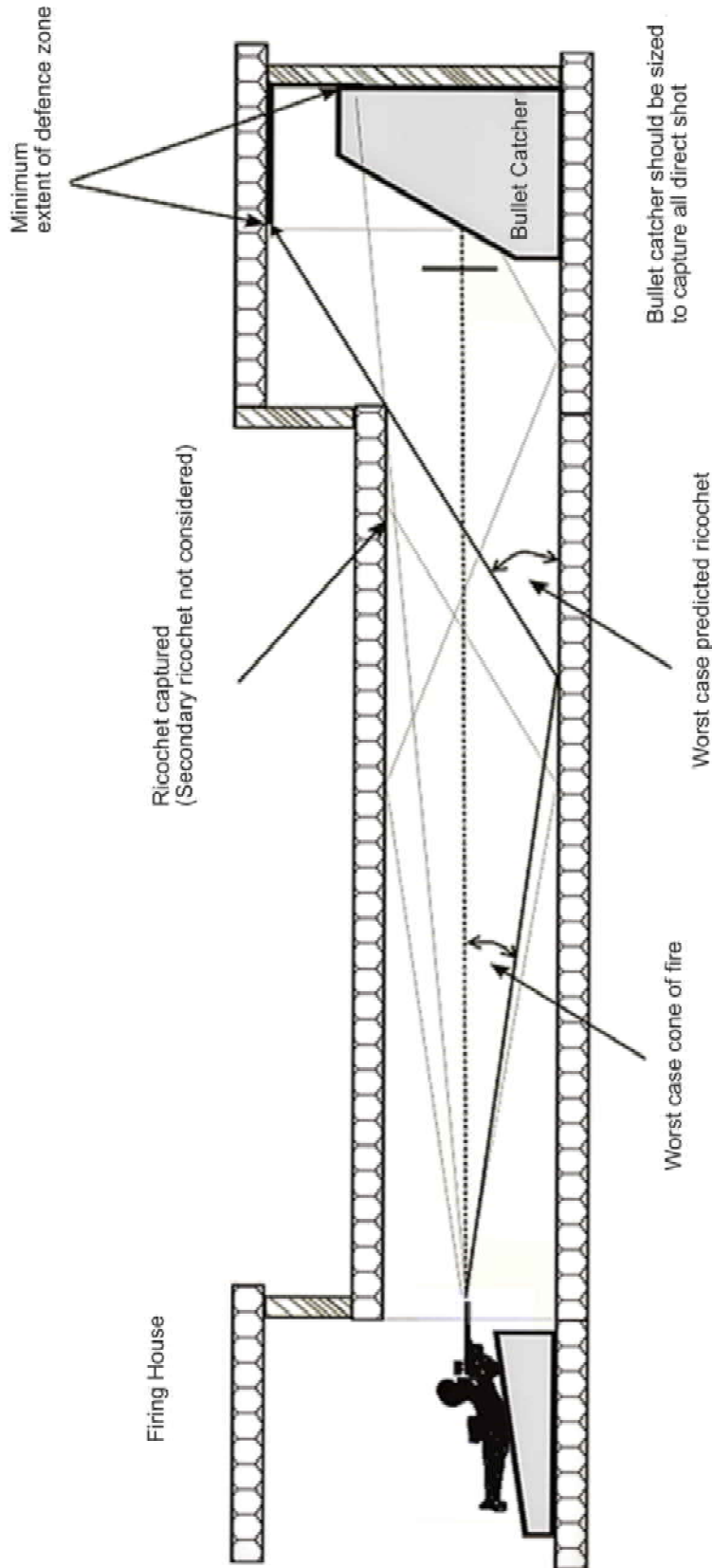

Fig 8 - 4. Typical Rimfire Tube Range



- Note:
1. Worst case ricochet off rough or soft surfaces for high velocity ammunition is 30° for low velocity it is 15°
 2. Ricochet off smooth hard undamaged surfaces is taken as half the impact angle.
 3. For cone of fire details refer to table 2-3, Chapter 2.
 4. Defence zone - where there is a target room - refer to table 2-6, Chapter 2.

Fig 8 - 5. Tube Range Criteria

Chapter 9 - The Baffle Range

The Baffle Range is a LDA range. It has baffles on either side and above the range floor intended to help prevent shots leaving the range. This chapter gives only very briefly the principles of the design as the baffle range is not one recommended by UK MOD for future developments. No work should start on design or construction of a Baffle range without consultation with RITT.



9-01. **Restrictions.** A baffle range reduces the area of land required for an open range but has the following restrictions:

- a. Firing may take place only from the fixed firing distances.
- b. The baffles reduce both wind and light.
- c. Design considerations generally make it impracticable for baffles to span more than six lanes without intermediate support.
- d. The range is very expensive to construct and to maintain.
- e. A DA may be required. Where it is assessed that ricochets can leave the range, an appropriate DA is to be determined which then must be suitably and sufficiently controlled.

Design

9-02. A combination of CoF and existing range NDA criteria can be used to design baffle ranges. Refer to RITT for details. Where down range access for plant is required the clearance for such plant, between the range floor and underside of the baffles, is to be considered in the design.

Situation

9-03. Several non-standard baffle ranges remain in service in the UK and in Germany and all have danger areas applied to them. In UK the baffle ranges have been assessed by WESCOE who have recommended the LDA that have now been applied. For Service personnel in Germany the GR LDA is applied from each active firing point to determine the table of restrictions on range complexes. The German cautionary zone, (full energy WDA) is applied beyond the bullet catcher.

Chapter 10 - The Grouping and Zeroing Range

Although Grouping and Zeroing (G&Z) may be carried out on most ranges, it is often expedient to include a G&Z range as part of a range complex to enable this task to be carried out concurrently with other shooting practices. The recommended distance for zeroing of Rifles is 25m with establishing the point of aim with the rifle at 100m. This chapter describes the construction requirements for G&Z ranges.

Range Danger Areas

10-01. The appropriate RDA will need to be controlled as per Chapter 2. The requirements for a G&Z range are:

- a. **FDA.** When open ground is used with or without a fall of shot bank (see paragraph 10-09), the WDA template shown at Fig 15 - 2 is applied to each firing point. See Fig 10 - 1.
- b. **LDA.** If the range is constructed to Gallery criteria using a mantlet and stop butt, the GR RDA may be applied. See Fig 10 - 2.

Siting

10-02. **Requirements.** A reasonably flat, northerly orientated, well drained site, about 120m long is required. The width of the range depends on the number and width of the firing lanes.

Range Floor

10-03. **Surface.** Depth of soil cover on the range floor is 150mm (S) and should be free from stones >30mm (S) in any direction.

10-04. **Lane Width.** The lane width is normally 6m (S) but this may be reduced to 4m (S) to reduce ground works if insufficient land is available.

10-05. **Distance and Lane Markers.** Timber markers are suitably positioned to show lane numbers and the firing distance of the firing points.

Firing Points

10-06. **Construction.** Firing point construction details are described in paragraph 2-81a. Where the Gallery Template is used the minimum height of the mantlet (see paragraph 11-24) must be visible to the firer in the prone posture or in a firing trench. To reduce ricochet, no ground or obstruction is to intrude into a line 450mm below the prone firer's LoS. New firing points on the range floor between the 100m firing point and mantlet need only to be marked with distance markers and lane numbers. In areas where the range floor may be eroded alternative materials may be incorporated such as those used on the main firing points. Firing point surfaces should be slip resistant, have no trip hazards, and designed to minimise maintenance bearing in mind that they are exposed to shot from firing points to the rear.

10-07. **Fire Trenches.** Properly drained fire trenches together with a post to simulate fire from cover are normally provided at the 100m firing point but may not be possible if the water table is high. Where the local risk assessment determines a potential hazard exists such as animals or people accessing the range when not in use, lids to cover the trench should be considered. Where trench covers are not suitable, warning signs around the area should be provided.

Construction

10-08. **General.** A G&Z range is shown in outline at Fig 10 - 1. The construction has been specifically designed to provide a cost effective, single task range.

10-09. **Fall of Shot Bank.** Typically, a 1.5 - 2.5m high bank is provided only to indicate fall of shot. Where a Fall of Shot Bank is constructed it should conform to the construction criteria for a Stop Butt to have 1.5m of stone free earth on the front with Sand Shooting in Boxes 1m deep along the line of fire to contain ricochet / backslash.

10-10. **Targetry.** Zeroing screens or AMS may be used, though any targetry systems are to be appropriately protected from strike.

- a. On full danger area ranges a target line, using timber (or other non-backsplash inducing materials) sockets, may be established 25m from the 100m firing point. However, the resulting lines of fire will need to be assessed to determine any impact on the range infrastructure and the danger area template.
- b. On G&Z ranges that operate on a Gallery Range template the zeroing targets are to be placed at the foot of the mantlet and a 25m firing line established. The mantlet will require shooting-in boxes to allow for de-leading.

10-11. **Firing Points.** Firing points are required to allow firing from all postures. Refer to paragraph 2-81a for details.

Communication

10-12. A means of summoning the emergency is to be available. Where a telephone tap-in point is used, it is to be constructed to the rear of the 100m firing point.

Maintenance

10-13. Ranges with a Gallery RDA template must be maintained to the full GR standard (see Chapter 11).

Compliance Checks

10-14. The following should be checked:

- a. Authorised weapons, ammunition, and practices.
- b. Ranges with a Gallery RDA template must be constructed to the full GR standard (see Chapter 11).
- c. Firing point type, dimensions, construction, lane identification, alignment and profiles.
- d. Full exposure of targets from all firing points.
- e. Template alignment.

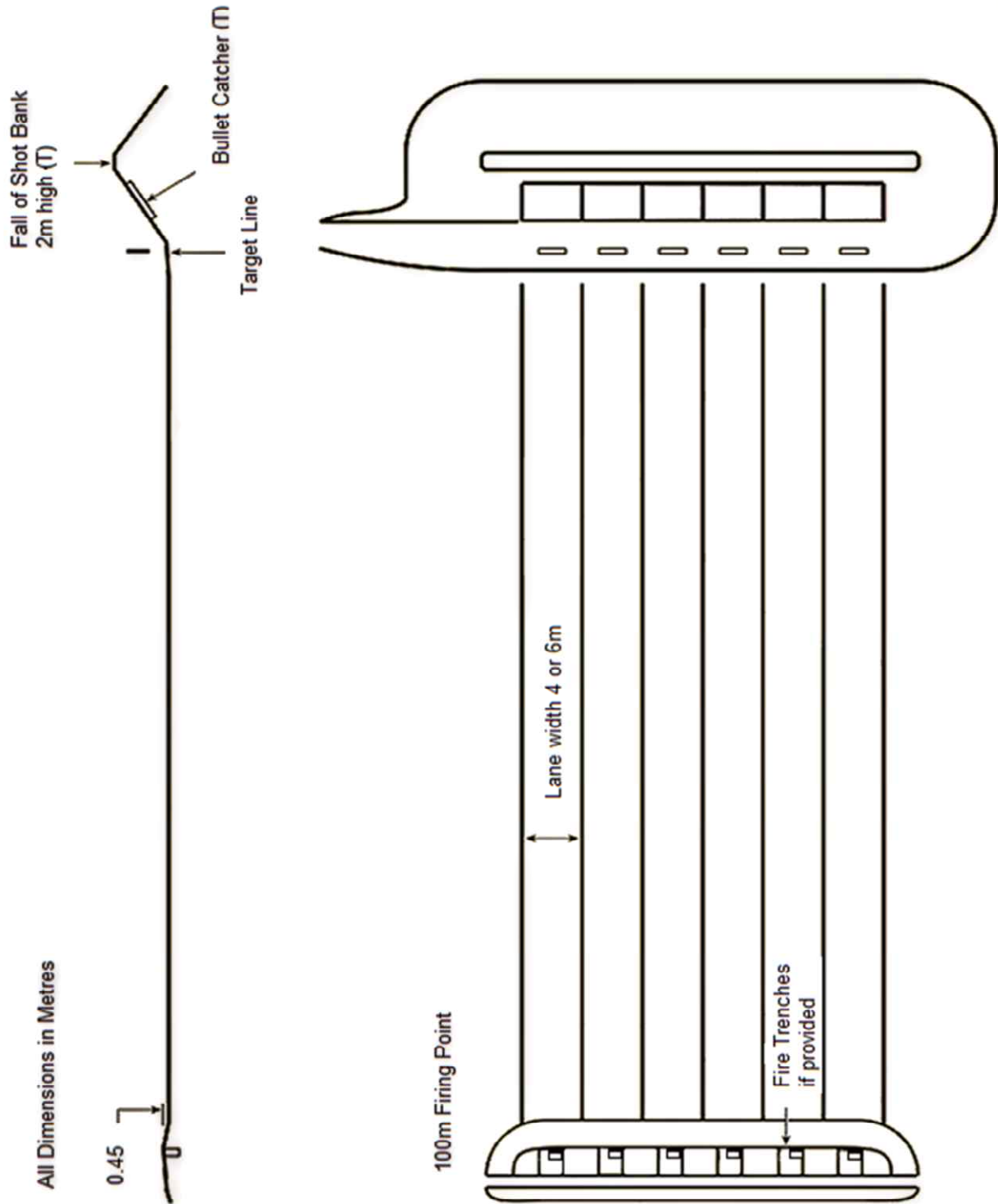

Fig 10 - 1. Typical G&Z Range

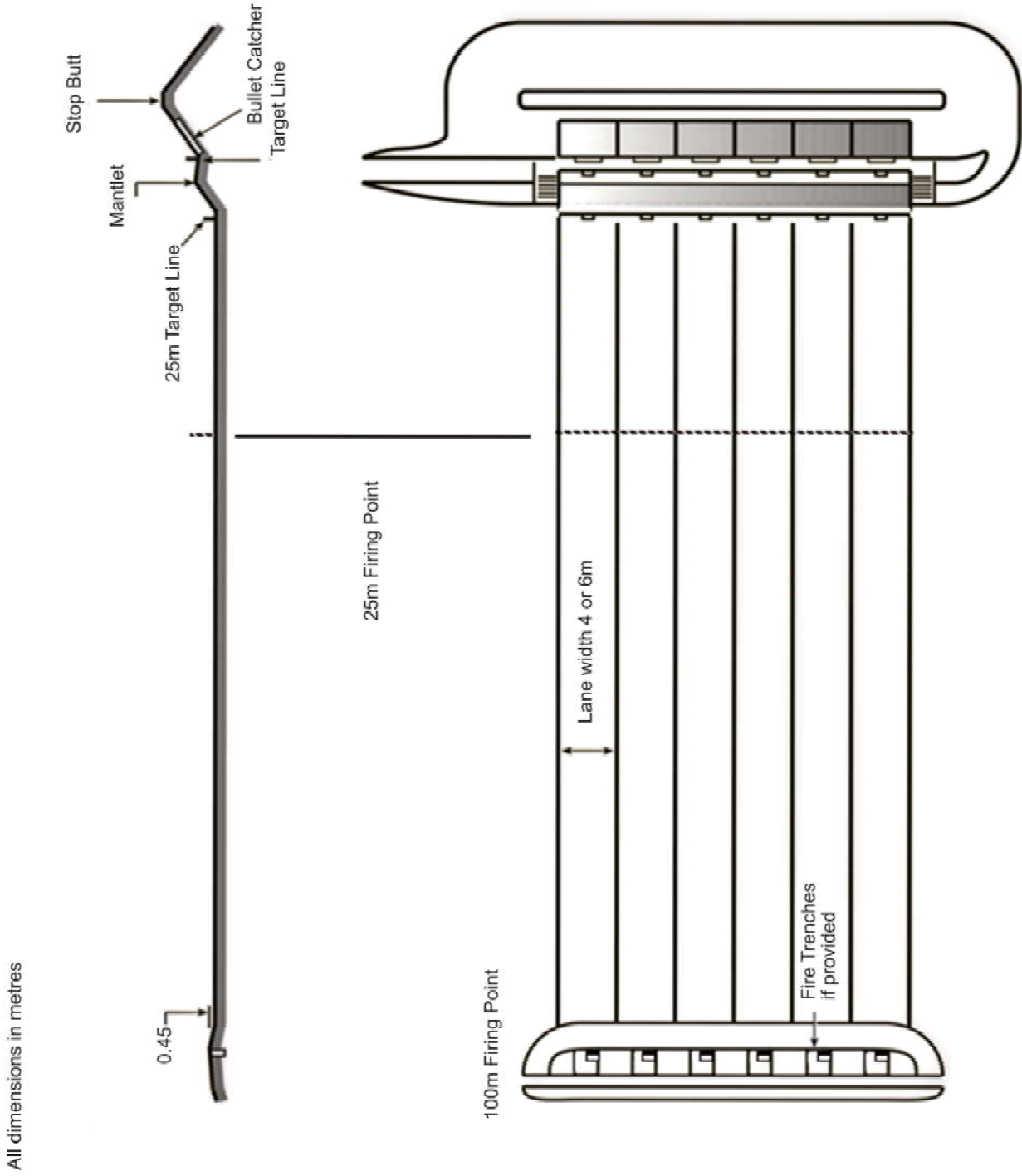

Fig 10 - 2. G&Z Range using Gallery RDA

Chapter 11 - The Gallery Range (Imperial and Metric)

A Gallery Range (GR) is an open LDA range originally constructed to imperial dimensions in yards (yds) or subsequently converted or partially converted to metres (m) with firing points at 100 intervals normally up to 600. On some ranges the 100 - 400m firing points only are converted to metric. This range has a markers' gallery and a stop butt. By convention where the stop butt and mantlet criteria are 3.05m (10ft) and 1.8m (6ft) respectively the range is referred to as imperial; where the criteria applied is 5.0m and 2.0m the range is referred to as metric. The common range layout has 12 firing lanes each 4m wide. Targets are manually operated by the markers in the butts. This chapter describes the design and construction of GR.

11-01. **Purpose.** A GR is suitable for practices at recruit and trained soldier level as set out in Operational Shooting Policy (OSP). Weapons typically used on this range include rifle, GPMG, and pistol. Tracer ammunition may also be used under the conditions set out in paragraph 11-03. Due to the revised pistol practices using the mantlet on GR or Gallery Type ranges should be confirmed by RITT. Combat shotgun may be used on this range providing the wider WDA can be accommodated, see paragraph 11-05b. OSP introduces many more practices forward of the 100m firing point into targets mounted in front of the mantlet such as that used with LNV practices, see paragraph 11-05d.

Danger Areas

11-02. **DA Categories.** Five DA may be applied to a GR:

- a. **Gallery Range DA Template.** The gallery range design is based around the principle of raising the targets off the range floor and thus reducing ricochet from ground strike. The template shown in Fig 11 - 1 can **only** be applied to a GR that fully conforms to the requirements of this chapter. The limiting QE_{max} of 70 mils (3.94°) is applied to an Imperial GR which achieves 1.8m(C) high of visible mantlet from every firing point and a stop butt height determined by a 3.05m boning rod. A portion of the CoF, when applied from the 100m/yd firing point in the prone position, exceeds the imperial stop butt height and therefore it is possible that some direct fire may not be captured. Where the QE_{max} is limited to 70mils, rounds will fall inside the RDA. A QE_{max} of 70mils equates to a QE_{tch} of 30mils (1.69°) + the cone of fire 40mils (2.25°). It is the QE_{tch} that can be measured on site. A metric GR with a 2m mantlet / 5m determined stop butt does not require a limiting of QE_{max} 70 mils (3.94°) as the CoF, , when applied from the 100m/yd firing point in the prone position, is captured by the stop butt and mantlet.
- b. **Extended Gallery Range DA Template.** Where a GR meets the criteria with the sole exception of QE an extended GR DA Template may be applied. This template is based upon ballistic tables and the length will be determined by RITT.
- c. **Weapon DA Template.** The template shown in Fig 15 - 2, in accordance with the CoF for fixed ranges (see Chapter 2 Table 3), is used when the stop butt and mantlet design criteria cannot be met, or hard ricochet inducing surfaces exist, and for falling plate practices which do not conform to the standards set out in this DCOP. This template may also be applied to those imperial GR where the QE exceeds 70mils.

- d. **Combined Gallery DA Template.** The templates at sub-paragraphs a and c above may be combined to overcome shortfalls in achieving the full GR criteria. When the full stop butt specification cannot be met, or the range floor conditions are such that GR criteria cannot be maintained, a combination of RDA and WDA templates may provide a solution. A key criterion is that the minimum height of mantlet, for imperial ranges (1.8m minimum) and metric ranges (2.0m minimum), is met, though not necessarily visible from all firing points. The template is produced after detailed survey of the range and its geometry matched by RITT to the requirements of approved RDA and WDA templates. The transition from the Gallery Template to the Weapon Danger Area (WDA) template occurs when the WDA template, from the firing point behind the point of failure, exceeds the Gallery Template. The WDA is applied from all firing points but only comes into effect beyond this transition point.
- e. **Hill Background Criteria.** The RDA may be reduced when there is a hill or cliff behind the range. The conditions required to meet hill background criteria are explained in Chapter 2. It is more usual to employ WDA Lab in the assessment of hill slopes behind ranges to determine any reduction in GR RDA.

11-03. **SA Tracer Ammunition.** Where 7.62mm tracer ammunition is used there is a requirement to extend the RDA 400m to the right flank around and behind the stop butt, 300m to the left flank and back splash up to 125m back from the stop butt. On ranges where stop butt and mantlet have no sand but are compacted earth, refer to Chapter 2 Table 2-2 Note 5. For 7.62 mm tracer the ADH increases to 1500ft. The tracer box shown in RED at Fig 11 - 2 must fall within the overall range DA. Tracer is not to be fired from the 100m firing point unless the stop butt is 25m or more beyond the target line. The gallery is not to be manned when 7.62mm tracer is fired unless additional protection such as timber boarding is provided between the stop butt and gallery.

11-04. **Other Factors:**

- a. **Burst Fire.** The rules for burst fire are given in Pamphlet 21.
- b. **Moving Targets.** The use of moving targets on a LDA (GR) type range is normally restricted to one 2.4m run at the centre of a 12-lane range. Advice from RITT should be sought if targets for more than one firer are required.
- c. **200 Mil Rule.** This reduction from the GR RDA is authorised only between a split or two standard GR / CGR or ET(LDA)R. On these ranges ground ricochet is limited by elevating the targets on top of a mantlet. With reduced ground ricochet a reduction in the flank safety angle (the 200mil rule) may be applied. For details on the application of 200mil rule refer to Pamphlet 21. The 200mil rule is not to be applied when ranges are used by Non-MOD Organisations (NMO). It can be applied by ranges used by Cadet Forces firing in or training for competitions with UK / Reserve Forces firers. Civilian firers are permitted to be in front but not behind any Cadet Forces on an adjacent range.
- (1) It applies only to Cadet Forces firing in competition practices using Target Rifle.
 - (2) All firers have followed and recorded in accordance with Service Manuals the progression of Live Firing Marksmanship Training.

- (3) Range SOs are updated to reflect the revised rule.
- (4) All RCOs / Template Controllers have received formal training From ARTAT, covering the application of the 200mil Rule and duties of a Template Controller.

11-05. **Practices on Gallery Ranges.**

- a. **Pistol Practices on a GR (excluding CQM).** The accepted location for targets engaged on standard GR pistol practices, from firing positions between the gallery and the stop butt, is at the bottom of the stop butt. On ranges where there is insufficient room between the gallery and the stop butt for pistol practices, targets mounted in front of the mantlet may be engaged. In such cases where the gallery detail between the stop butt and gallery is non-standard, advice from RITT should be sought to ensure the pistol template is contained within the gallery RDA. In all cases the pistol 135mils template is to be applied to ensure flank firing position templates are contained within the range RDA.
- b. **Combat Shotgun Practices on GR where the WDA can be accommodated.** (See Figs 15 - 6 and 15 - 7). Combat shotgun (slug and buckshot) may be fired at targets in lane mounted on the range floor in front of the mantlet, providing that a shooting-in box or full sand mantlet is present. Flank lanes are not to be used. No engagement of targets closer than 25m. Those ranges with dense rubber tiles fitted on the mantlet are also suitable for shotgun practices.
- c. **Sniper Practices.** Service Sniper practices using .338" (8.6mm) ammunition may be permitted on the GR or CGR with a stop butt extending at least 1.5m above the top of the target when viewed from the prone position at 100m. When firing using .338" (8.6mm) ammunition sniper practices set out in OSP.
- d. **Limit of Night Visibility and ACMT 50m Practices.** If the GR has a 1830m RDA, the engagement of targets at the Limit of Night Visibility (LNV) is to be conducted with targets mounted on the range floor immediately in front of the mantlet. To allow firing in all postures, target centres must not exceed 1.5m off the range floor. No engagement closer than 25m from the mantlet nor further than 75m from the targets. Engagement beyond 75m must take place from the 100m firing point at Gallery or FET mounted targets. For ACMT practices targets are normally placed on the range floor in front of the mantlet. The increased volume of lead fired into the mantlet may require the provision of shooting in boxes behind each of the targets, see paragraph 11-24. For both LNV and ACMT practices the gallery or FET targets may be utilised where a 2900m FDA is provided or QE and LDA allow. Advice from RITT should be sought in all cases where there is only an LDA.
- e. **CQM LFMT Practices.** These practices will put firers inside the backslash distance and significantly effect LoF therefore further infrastructure and / or control measures will be required, in addition to the requirements set out in this Chapter, to safely conduct CQM. This will include provision of a shooting in box and may require changes to the RDA. Advice must be sought from RITT to conduct CQM practices on a GR.

Design

11-06. **Principles.** The GR design is based on principles that have evolved since about 1909. Current design of the stop butt is based on firing from the 100m firing point on the basis that weapons are zeroed from this distance and minimum grouping is achieved before firers move back to the other firing positions. The historic application of criteria is taken from the centre line of the firing point. Specific information is provided below:

- a. **Target Height.** Targets are placed above the mantlet so that the CoF is raised above the range floor and thereby reduces the incidence of ground ricochet. Some ricochet is inevitable, but it will be either stopped by the mantlet or stop butt or contained within the RDA. To ensure that on existing ranges with 1.8m mantlets / 3.05m determined stop butts the occasional shot passing over the stop butt will fall within the RDA, it is necessary to apply the QE restriction as described in paragraph 11-06d.
- b. **Stop Butt Height.** The height of the stop butt is based on criteria applied from the 100m firing point only for the following reasons:
 - (1) The QE to the maximum target centre height being greater from the 100m firing point than from further distant firing points.
 - (2) The greater deviation of weapons being zeroed at the 100m firing point.
- c. **Stop Butt Profile.** The slope of the stop butt face reduces the probability of ricochet from shot fired at the target centre.
- d. **Quadrant Elevation.** Quadrant Elevation (QE) to ensure that on existing imperial GR and CGR the occasional shot passing over the stop butt will fall within the RDA, it is necessary to apply a restriction as described in paragraph 11-02a. QE_{act} is measured by assessing QE to maximum target centre (QE_{tch}) and adding the respective CoF. Where ranges are found to have a QE_{tch} more than 30mils RITT will advise on the options available to ensure all rounds are captured. Solutions may include adjusting the range geometry, metrication of the stop butt and mantlet or the extension of the RDA based on worst case ammunition trajectories.

11-07. **Siting.** Careful site selection for the GR should enable construction without extensive earthworks. A site on level dry ground is preferable with the LoF in a northerly direction. Consideration is also to be given to the level of risk around the DA boundary when choosing the alignment of the range and this should take precedence over the problem of firing into the sun. Ground producing a depressed line of sight with a flat or slightly concave range floor is ideal. Rising ground may require additional earthwork to raise the more distant firing points. Rocky, marshy or undulating ground should be avoided as should sites that would produce a very hollow range floor (see Fig 11 - 3).

Construction

Stop Butt

11-08. **Purpose.** The stop butt stops most aimed direct shot and low angle ricochets. It also allows the firer and coach to observe the fall of shot. Sand or granulated rubber bullet catchers should also be incorporated into the stop butt behind the target positions for ease of maintenance (see paragraph 11-14).

11-09. **Location.** The stop butt is sited behind the targets, and it will normally be at right angles to the range centre line but a maximum deviation of 180 mils (100) is permitted. It should not be less than 25m from the gallery target line to prevent backslash into the gallery. The space can also be used for shooting at 25m provided the stop butt meets the criteria in this Chapter. CQM practices can be conducted in this space, subject additional checks, advice must be sought from RITT to achieve this. On ranges where the stop butt is less than 25m provision must be made to prevent backslash into the gallery. See Chapter 2 Table 2.

11-10. **Structure.** The stop butt is a bank constructed from stone-free soil. It may have a rock core faced with a minimum of 1.5m of compacted soil free from large stones (>30mm (S) in any dimension). Measures to reinforce stop butts to take account of local climatic conditions should be used particularly where stop butts are constructed entirely of sand. Timber framing or geo-grid around shooting in boxes have proven to be successful solutions.

11-11. **Height.** The height of the stop butt is determined by setting a boning rod on top of the mantlet and, when viewed from the prone position, at the 100m firing point, the crest of the stop butt, should not appear lower than the boning rod, along the whole length of the stop butt. Where a GR exceeds the QE restriction, lifting the stop butt and mantlet to meet the metric standard will provide a solution. The minimum height for the stop butt boning rod is to be 5m (C) though on existing imperial ranges it may be 3.05m (C) as illustrated in Fig 11 - 4. It must however be established that the mantlet is the correct height (see paragraph 11-23).

11-12. **Crest Length and Width.** The length of the stop butt crest is determined when a horizontal angle of 60mils (3.4°) applied to each flank LoS on the 100m firing point meets the line of the stop butt crest as shown in Fig 11 - 4. The stop butt should be level across the crest and not less than 1.5m wide over the full length.

11-13. **Profile.** The face profile of the stop butt is constructed and should be maintained at an angle of 600mils (34°) (S) to the horizontal (2:3). The minimum face angle of 533mils (30°) (C) must be achieved to limit ricochet. The rear of the stop butt and its ends should be constructed at the natural angle of repose for the soil type. Stability can be enhanced with geotextiles, geogrids, or a combination of the two, and the surface should be seeded to assist stability. If drainage or soil types make these slopes impracticable, the face of the stop butt may be terraced. The design of a terraced stop butt must avoid terrace steps in the main impact area behind the targets (see paragraph 11-17).

11-14. **Bullet Catcher or Material Boxes.** A sand or granulated rubber bullet catcher should be formed on the face of the stop butt. With sand, this will help with identifying the fall of shot and with either, will simplify de-leading. The depth and specification for sand or granulated rubber are given in Chapter 2. To assist in maintaining the profile, these boxes may be constructed of timber and set into the stop butt. The height and width of the box is to be such that when a 1.22m² (4ft²) target is installed, at least 0.3m of material all around it is visible to the firer from the 100m firing point. Granulated rubber should not be placed over the whole stop butt due to the fire risk. It is easier to control a fire in smaller shooting in boxes. Light rubber sheet may be used to retain the granulate in the boxes following bullet strike. This also helps prevent debris getting into the granulate.

11-15. **Flagpoles and Lights.** A range in use flag or light as described in Chapter 2 must be provided.

11-16. **Lane Numbers.** Lane numbers constructed of timber and Weather and Boil Proof (WBP) grade plywood as shown in Fig 11 - 5 are positioned at the foot of the mantlet. The lane numbers should be 1m high and painted black in silhouette or white numbers on a 1.2m high black background. On ranges more than 600m, the height of the numbers should be increased to 1.4m. For night firing or falling plate practices, the lane numbers must be removable.

11-17. **Terracing.** This may be used where conditions dictate that a single slope cannot be maintained. However, there will be significant maintenance requirements to ensure that the terraces remain compliant.

a. **Hill Stop Butts.** Engineering considerations may make it necessary to terrace a stop butt such as when a hill is used. Each terrace must be cut with a face angle of 34° (2:3) (S) and the top of the terrace sloped back from the face at 4.8° (1:12). Terraces may be wide enough to accept a small excavator but the possibility of ricochet from the edge will limit the depth of each terrace to ensure capture of the round by the terrace above. Terraces are to be constructed to avoid the main area of impact behind the targets.

b. **Stop Butt and Mantlet Cross-fall.** When a cross-fall exceeds 2.3° (1:25), it will be necessary to form a step or steps in the length of the stop butt and mantlet. The slope should be formed at the natural angle of repose for the soil and the resulting horizontal slope length added between lanes. To meet the minimum crest width, lower levels will have an increased crest width to avoid a change in the face angle. A step in the stop butt must be offset from the step in the mantlet to cover the flank angle distance (60 mils (3.4°)) from the LoS at the 100m firing point. The requirements for a stepped stop butt and mantlet are shown in Fig 11 - 5.

Markers Gallery

11-18. **General.** The markers' gallery is designed to work with the Hythe target frames. It must provide sufficient height to allow both front and back targets to be lowered out of sight of the firers and to enable the marker to paste up a 1.8m screen without standing on a step or reaching above the gallery roof. This is not easily achieved and the design dimensions for gallery construction must be carefully adhered to. Figs 11 - 7 and 11 - 8 show a typical layout and cross-section of a gallery and the design requirements. The gallery should be at right angles to the axis of the range but, like the stop butt, a deviation of $180\text{mils } 10^{\circ}$ is permitted. It is desirable that the gallery and stop butt are parallel, but this is not essential. See also paragraph 11-03.

11-19. **Construction.** The construction should be of brick or concrete, pre-cast concrete cantilever sections are ideal. Provision must be made behind this wall for the relief of hydraulic pressures. The target trench is the lowest point in the gallery and must be properly drained by laying the bottom of the trench to a self-draining fall from the centre out towards each end of the gallery or from one end to the other over its full length. From the end the drainage may lead into the range drainage system or into a soakaway. It may be necessary to install a lift pump, but every effort must be made to prevent flooding in the gallery area.

11-20. **Fixtures.** A seat for each marker is fixed to the gallery wall opposite each target and provision made for telephones. A red butt flag of minimum size of 1.2m x 0.9m, visible from all firing points mounted on a non-ricochet inducing material flagpole is fixed to one end of the gallery. Access to the gallery is at this end.

11-21. **Target Spacing.** Ranges built to imperial units have target spacing which give a lane width of 4yds (3.66m). This is the minimum requirement to ensure sufficient working space for markers in the gallery and to give sufficient visual separation between targets. Even at short range, firers may have difficulty identifying their targets if this spacing is reduced. On new ranges lane widths should be a minimum of 4m.

11-22. **Target and Target Frames.** The in-service target frame is the 'Hythe' pattern shown in Fig 11 - 9. The original frames were built of malleable iron and are normally supplied by McQueen's Ltd of Galashiels who hold the original drawings. The calculations for setting the height of the target frames are critical for the safe operation of the range. Great care must be taken in ensuring accurate design and setting out the work. Details of the modifications to be made to the target carriages for fixing Fig targets and target poles are shown in Fig 11 - 10. The legs of the targets used in target frames must allow the bottom edge of the target to show 75mm above the crest of the mantlet as seen from all firing points (see Fig 11 - 11).

Mantlet

11-23. **Length and Height.** In terms of safety, it is the mantlet that determines whether the range is an imperial or metric range. Whenever possible, the mantlet length should be extended beyond the flank targets to protect structures at the ends of the gallery. As a guide the flanks of the mantlet should be in the LoS from the 100m firing point to the flanks of the stop butt. The minimum height, visible from all firing points in the prone position, of the mantlet is to be 2m (C). On existing imperial ranges the minimum is 1.8m (C) (see Fig 11 - 4). The mantlet and the stop butt height are key factors in justifying confidence in the capture of direct aimed shot and low, long ranging ricochets.

11-24. **Construction.** A typical cross section of a mantlet is illustrated in Fig 11 - 8. The mantlet is formed of compacted soil free from stones (>30mm (S) in any one dimension). It must not be less than 1.5m (C) thick at any point. A rock or rubble core may be incorporated providing there is a minimum of 900mm (C) of stone-free cover measured along the LoF. The forward face should be constructed to a slope of 34° (S) (2:3), minimum 30° (C) to the horizontal, however excessive elevation or depression on LoF may require additional consideration. Due to increased use of targets mounted on the range floor in front of the mantlet, shooting in boxes 1.4m x 1m wide (T) should be provided in each lane to facilitate effective de-leading. The depth and specification for sand or granulated rubber are given in Chapter 2. To reduce ricochet the top of the mantlet is raked back to a slope of 1:12 (S) below the highest LoS. To ensure that the correct height and width are maintained, the crest of the mantlet is defined by a timber profile board set on edge along the full length of the mantlet. The signage and protection provided on the mantlet to comply with statutory regulations is to be dictated by local risk assessment based on the degree of permitted and unauthorised access onto the mantlet.

11-25. **Construction of Shooting in Boxes (less CQM).** Shooting in boxes are provided to take most rounds fired at targets placed in front of the mantlet and as such need to be constructed around each target array. The boxes are to be made of a soft material such as timber that will not generate hard ricochet. There will always be wide shot that will damage the materials used in constructing these boxes so this should be taken into consideration when choosing the material used. On ranges where GPMG is used extensively, attrition to the mantlet may be high. Targets are normally positioned in pairs within a 4m lane on GR. Mantlets vary greatly in layout so the actual size and position of shooting in boxes may vary from range to range; a typical layout is shown below:

Mantlet Conversion
Typical detail to capture the majority of shot
fired in order to ease maintenance

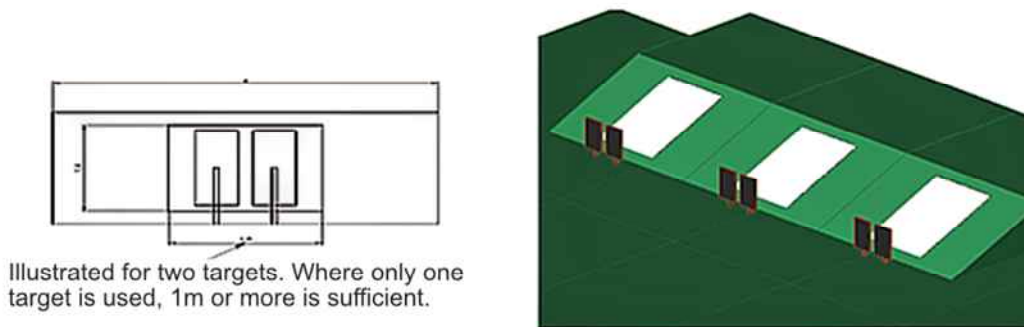

Fig 11 - 1. Mantlet Conversion

11-26. **Falling Plate Targets.** Falling plate shooting-in boxes set into the face of the mantlet lower the CoF, which increases the risk of ricochet off the range floor and therefore requires the 2900m RDA template to be applied (see Fig 11 - 3). To avoid lowering the CoF, shooting-in boxes may be set into the stop butt between target frames on the normal LoS. However, as this creates a backsplash hazard, the markers' gallery should not be manned. To fire falling plate practices on gallery ranges without the need to increase the Gallery RDA, falling plate boxes or covers over the steel plates mounted on the mantlet may be used (5.56mm only; refer to RITT for details). Only the issued falling plate targets are to be used (see Chapter 24).

Target Store and Workshop

The preferred position for the target store and workshop is at one end of the markers' gallery (see Fig 11 - 7). On ranges with up to twelve targets it will be found that a combined target store and workshop will be adequate. In the case of larger ranges, it is advisable to have the workshop sited centrally and the target store sited in the gallery. The workshop should be equipped with a large flat-topped target table, a carpenter's bench, cupboards, and adequate heating and lighting. A water supply is desirable. RAU should be aware that most target stores and workshops on GR are located within the GR RDA. Personnel in this area are exposed to rounds that "pop over" the stop butt. All those in the workshop / store area whilst firing is taking place are to be under cover protected from potential pop over. The CGI or profile steel roofing typically found on workshop / store roofs has been shown to provide protection from pop over.

Range Floor

11-27. **Levelling.** Visibility of targets must be maintained throughout, when advancing from the 400m firing point forward. Drainage ditches, streams etc need to be culverted and brought approximately to ground level. It is not satisfactory to place footbridges across such obstacles as timber will become slippery, and steel and concrete are a ricochet hazard. Depth of soil cover on the range floor is 150mm (S) and should be free from stones >30mm (S) in any direction.

11-28. **Distance and Lane Markers.** Timber markers are suitably positioned to show lane numbers and the firing distance of the firing points.

Firing Points

11-29. **Construction.** Firing point construction details are shown in Fig 2 – 16 and described in paragraph 2-77a (including sub-paras). The minimum height of the mantlet (see paragraph 11-23) must be visible to the firer in the prone posture or in a firing trench. New firing points on the range floor between the 100m firing point and mantlet need only be marked with wooden pegs with lane numbers. In areas where the range floor may be eroded alternative materials may be incorporated such as those used on the main firing points.

11-30. **Surfaces.** Firing point surfaces should be slip resistant, have no trip hazards, and designed to minimise maintenance bearing in mind that they are exposed to shot from firing points to the rear.

11-31. **Fire Trenches.** Properly drained fire trenches together with a post to simulate fire from cover are normally provided at the 100m, 200m and 300m firing points but may not be practical if the water table is high. The trenches may be revetted with timber or pre-formed concrete sections with a timber surround at the top to prevent ricochet (refer to paragraph 2-81. a. (7) (b)). Where the local risk assessment determines a potential hazard such as animals or children accessing the range, lids to cover the trench when it is not in use should be considered. Where trench covers are not suitable, warning signs around the area should be provided.

Communications

11-32. **External.** A means of summoning the emergency services, ideally a land laid telephone is to be available.

11-33. **Internal.** Provision should be made for the following telephone communications where still used and serviceable:

- a. **Gallery.** The connection point in the gallery should be placed centrally to each bank of twelve targets and is to be an external weatherproof fitting made vandal-proof by putting it into a secure access box with the cable in securely fixed trunking. The spur that runs to the side of the range to connect with the line from the firing points is in a cable duct buried 600mm deep.
- b. **Firing Points.** The connections at the firing points are to be external weatherproof fittings located to the rear of the firing point. Preferably the connections are set below ground in a damp-proof container with a 5mm thick timber lid set flush with the range floor. An above ground connection point should be provided on a pole set as low as possible but not more than 500mm high protected by 100mm thick timber or 500mm of earth ramped up from the range floor.
- c. **Inspection Pits.** All inspection pits on or adjacent to the range floor are fitted with 50mm thick timber covers set flush with the range floor.

Maintenance

11-34. **Range Profile Survey.** The effects of weathering, soil movement and attrition will cause changes in the range profile. Range inspectors should call on RITT if they are in any doubt on ballistic element compliance.

11-35. **Responsibilities.** Maintenance is the responsibility of the RAU. Responsibilities may be divided as follows:

- a. **Range Warden.** DSA 03.OME Part 3 Volume 1 Part 2.
- b. **Property Management:**
 - (1) Grounds.
 - (2) Fencing and sign posting (See Chapter 2).
 - (3) Structures, roads and drainage including stability of slopes and erosion control.
 - (4) Water and electricity supplies.
 - (5) Periodic refurbishment of the range structure.
- c. **Equipment Management.** Repairing and servicing equipment installed by Single Service Contract.

11-36. **Frequency.** Proper maintenance is dependent upon good liaison between the Range Warden and the RAU, and on properly scheduled maintenance periods. A heavily used range may need one day's maintenance each week plus one- or two-days' maintenance by the Range Warden each month. Two closed periods of a week or so may be needed each year for building and earthworks repair; this work should be combined with the contract repair of equipment.

11-37. **Mantlet Scooping.** Low shots can cause deep scooping to the front of the mantlet in line with the targets. This can generate high ricochet and may allow shot to penetrate through the mantlet to strike target frames. Maintaining the mantlets correct profile is essential. Where scooping occurs the range configuration should be checked, especially target clearance above the mantlet. Should the configuration be correct, shooters need to be made aware that they should be aiming correctly and should avoid low shot. As a final resort, timber or shredded rubber / polymer block may be used to minimise the maintenance effort though minimum target clearance must be maintained (see Fig 11 - 12).

Compliance Checks

11-38. The following areas are considered during a compliance check:

- a. Authorised weapons, ammunition, and practices.
- b. Firing point dimensions, construction, lane identification, alignment, and profiles.
- c. Visibility of required mantlet face from all firing points.
- d. Mantlet profile, height, and width.
- e. Full exposure of all targets from all firing points, spacing identification, and target centre height.
- f. Minimum clearance over mantlet crest board.

UNCONTROLLED COPY WHEN PRINTED

DSA 03.OME Pt 3 Vol 2 Ch 11

- g. Minimum clearance over Hythe Frame.
- h. Stop butt alignment, distance from target line, size, and profile.
- i. Falling plate target position and construction, if applicable.
- j. Quadrant Elevation to target centre (CoF then added to determine max QE_{act}).
- k. Template alignment.

All dimensions in metres

Not to Scale
Not to be Copied

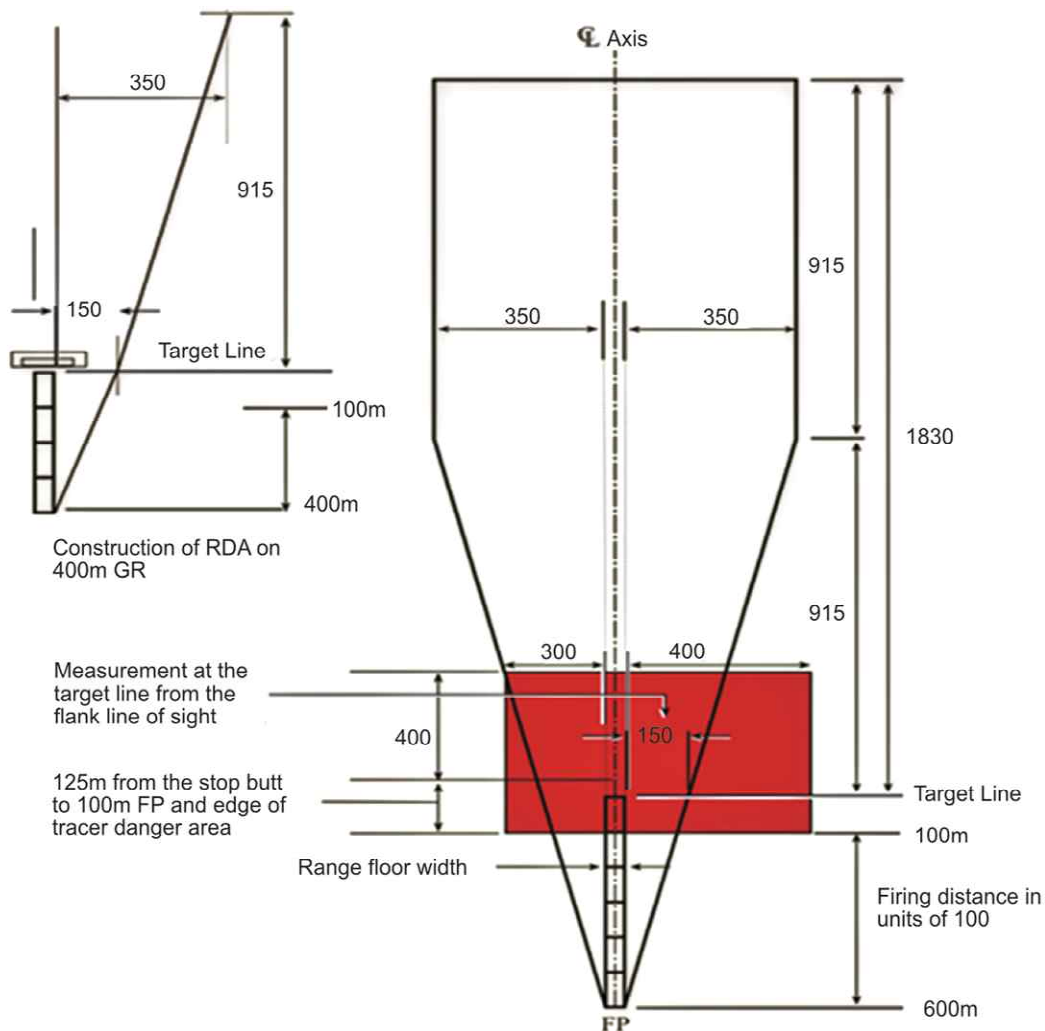

Notes:

1. ADH: 5.56 & 9mm 500ft, 7.62 Ball 750ft, 7.62 mm Tracer 1500ft AGL.
2. When firing 7.62 mm Ball an air sentry may be required.
3. This template only applies to ranges built to metric standards and to those constructed with a QE restriction (QE_{max}) of 70 mils (30 mils to target centre QE_{tch}).
4. Maximum MV/ME permitted - see Chapter 2 Table 2-4.
5. Tracer DA shown in red (5.56mm tracer may be treated as Ball ammunition).

Fig 11 - 2. RDA Template Gallery Range

a. Poor
Full target not visible from 100m.

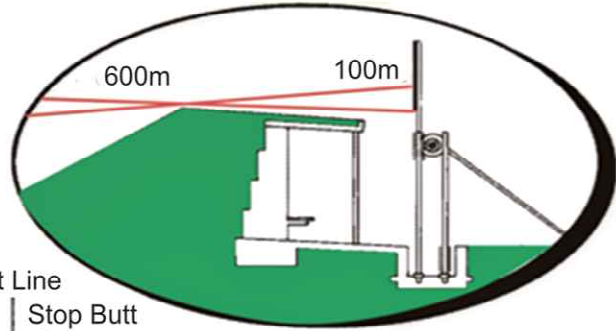
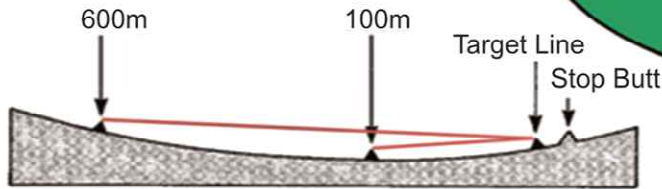

b. Poor
Strike on frame possible.

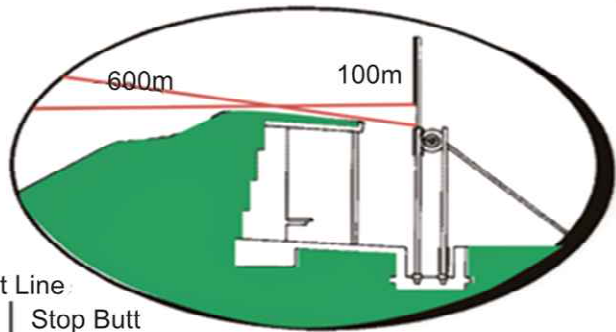
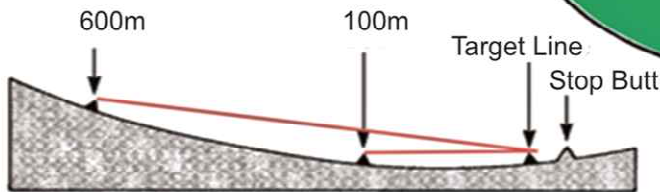

c. Good Alignment

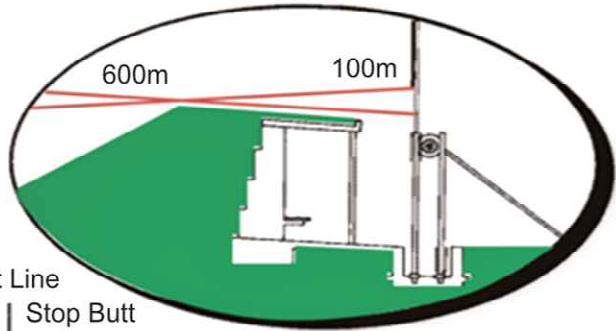
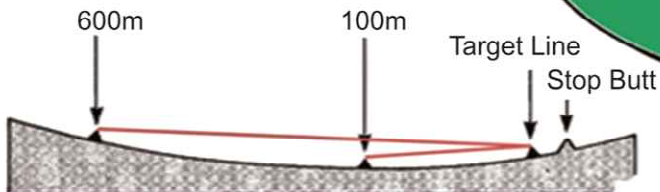
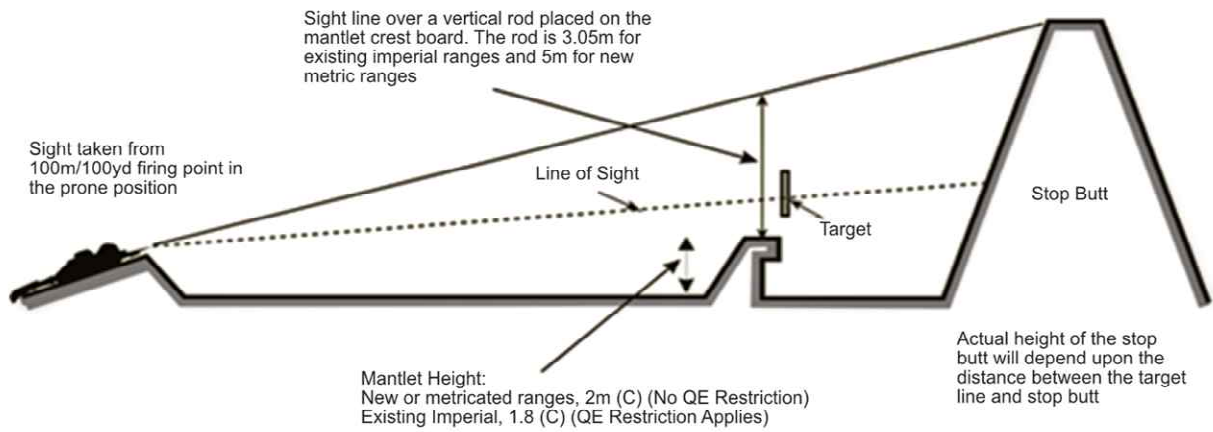
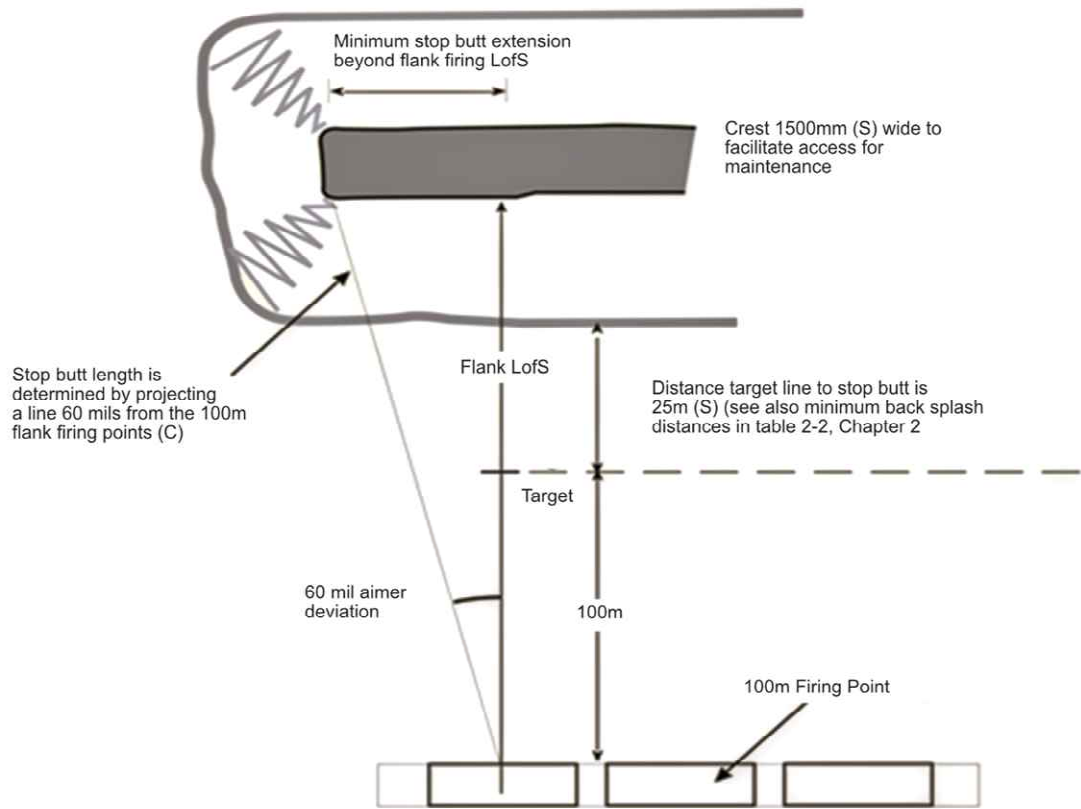

Fig 11 - 3. Effects of Hollow Sites



Stop Butt Height



Stop Butt Length

Fig 11 - 4. Determination of Stop Butt Height & Length

All dimensions in millimetres unless otherwise stated

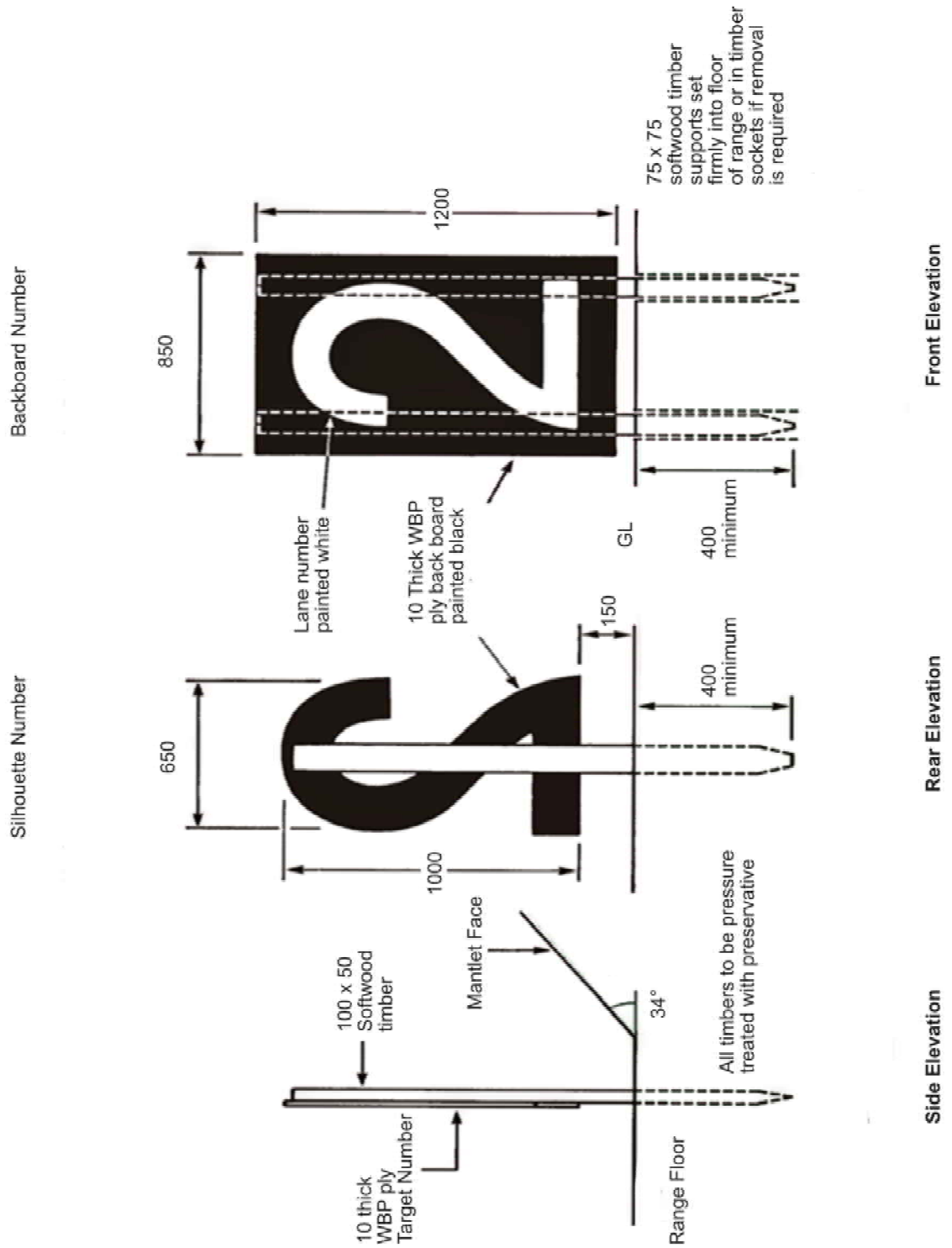
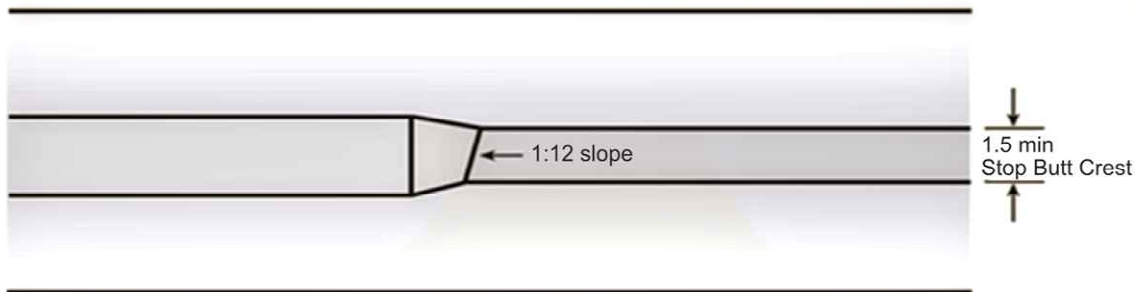
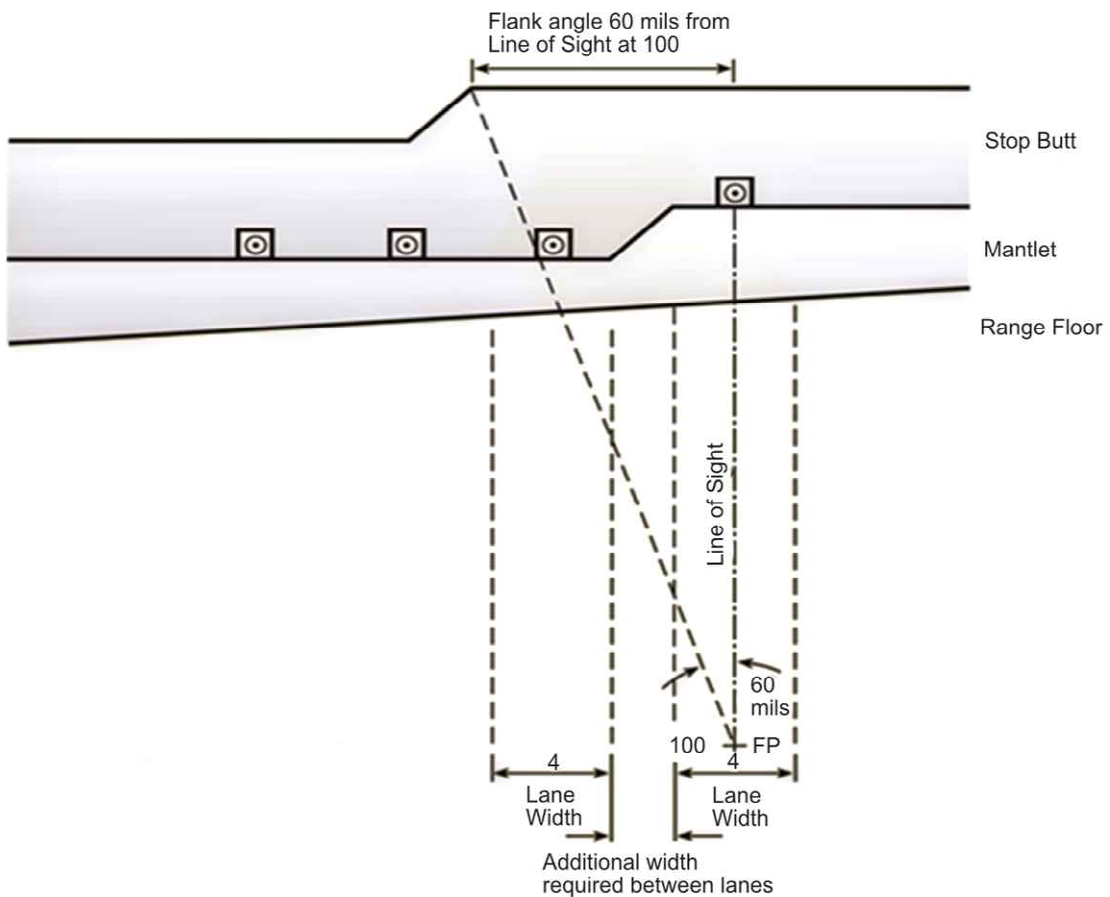

Fig 11 - 5. Lane Marker Numbers

All dimensions in metres unless otherwise stated



Plan View of Stop Butt



Elevation
Mantlet & Stop Butt

Fig 11 - 6. Stepped Mantlet and Stop Butt

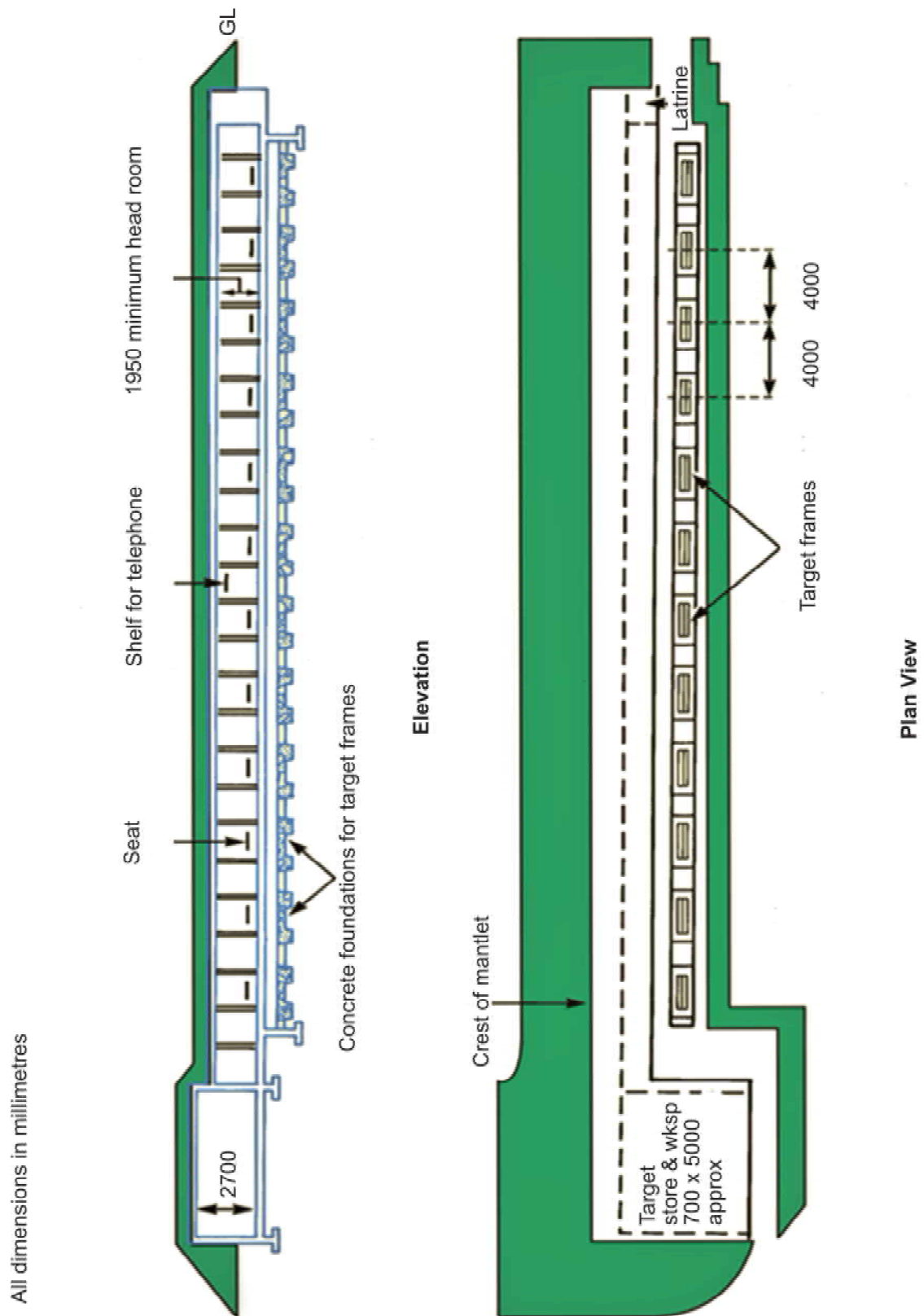
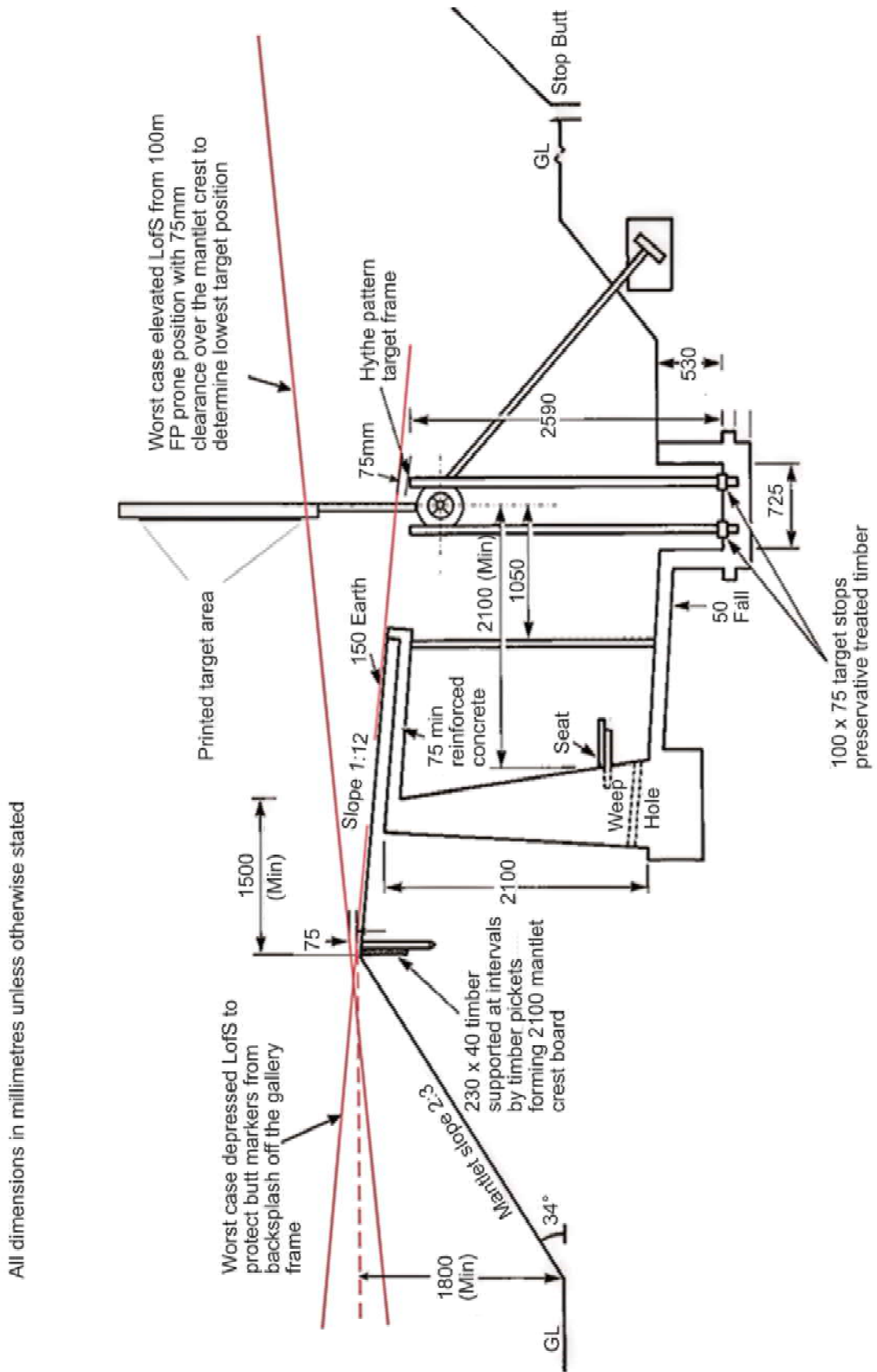

Fig 11 - 7. Markers' Gallery Layout



All dimensions in millimetres unless otherwise stated

Fig 11 - 8. Markers' Gallery Detail

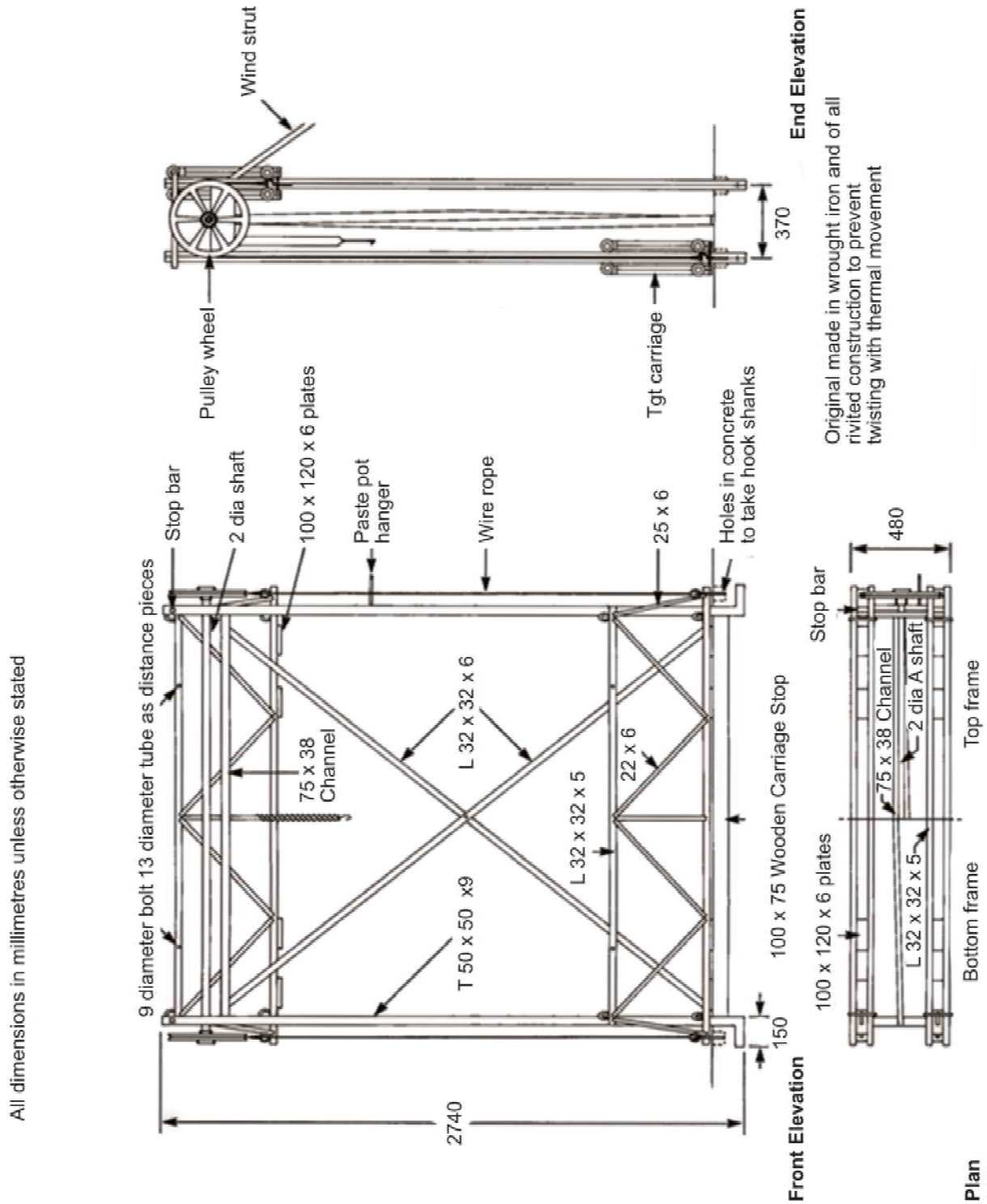

Fig 11 - 9. The Hythe Pattern Target Frame

All dimension in millimetres unless otherwise stated

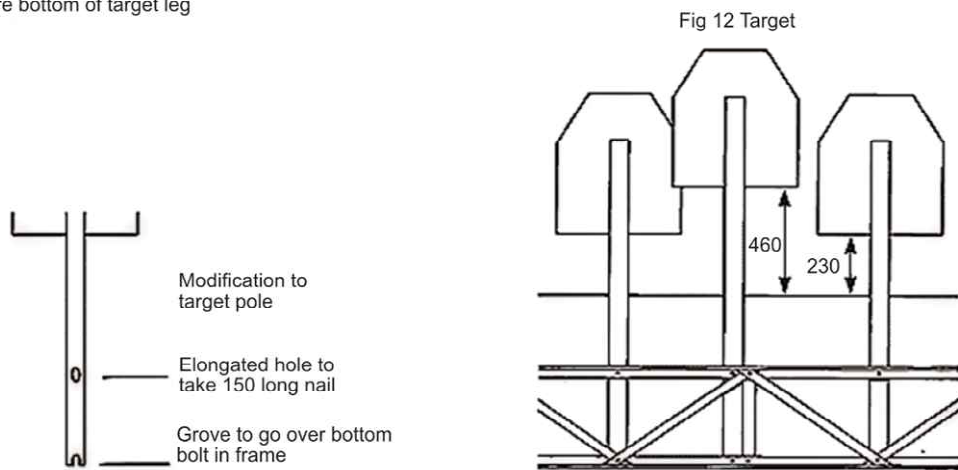
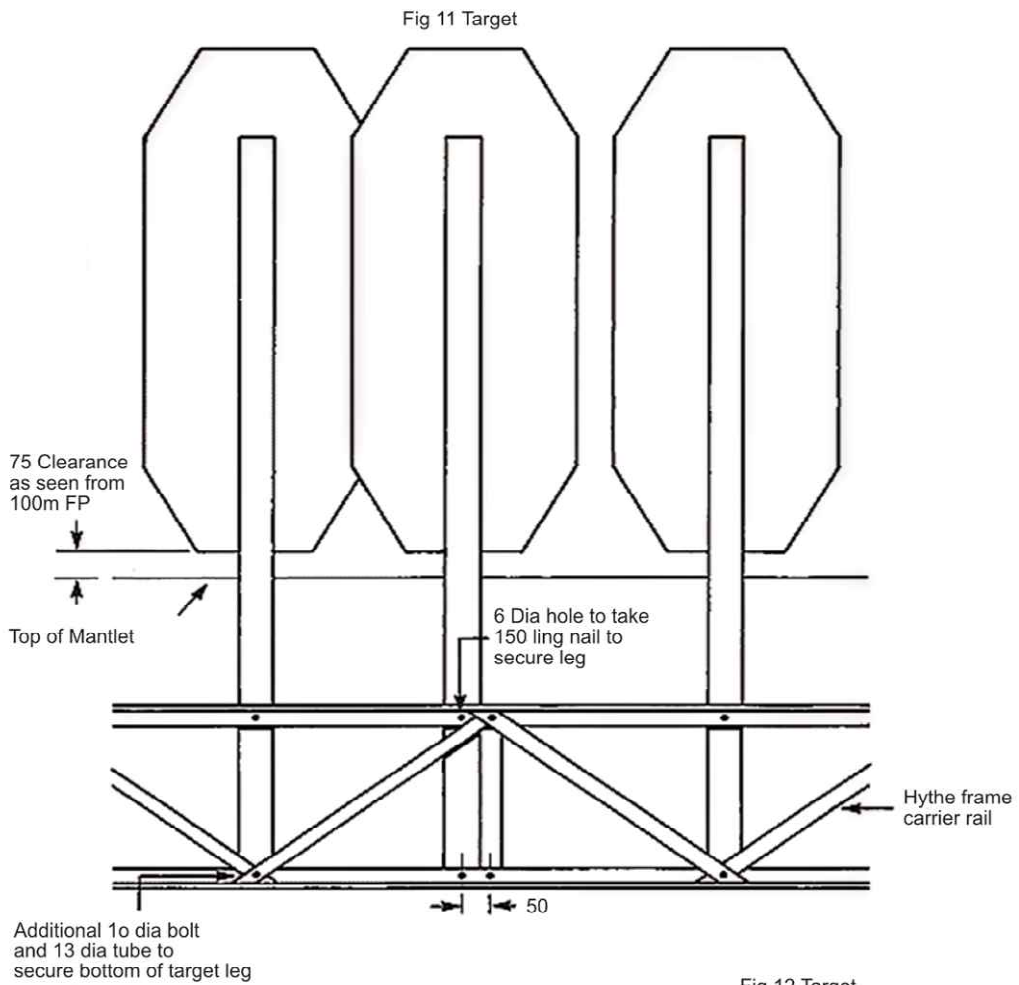

Fig 11 - 10. Fixing Detail for Fig Target in Hythe Frames

All dimension in millimetres unless otherwise stated

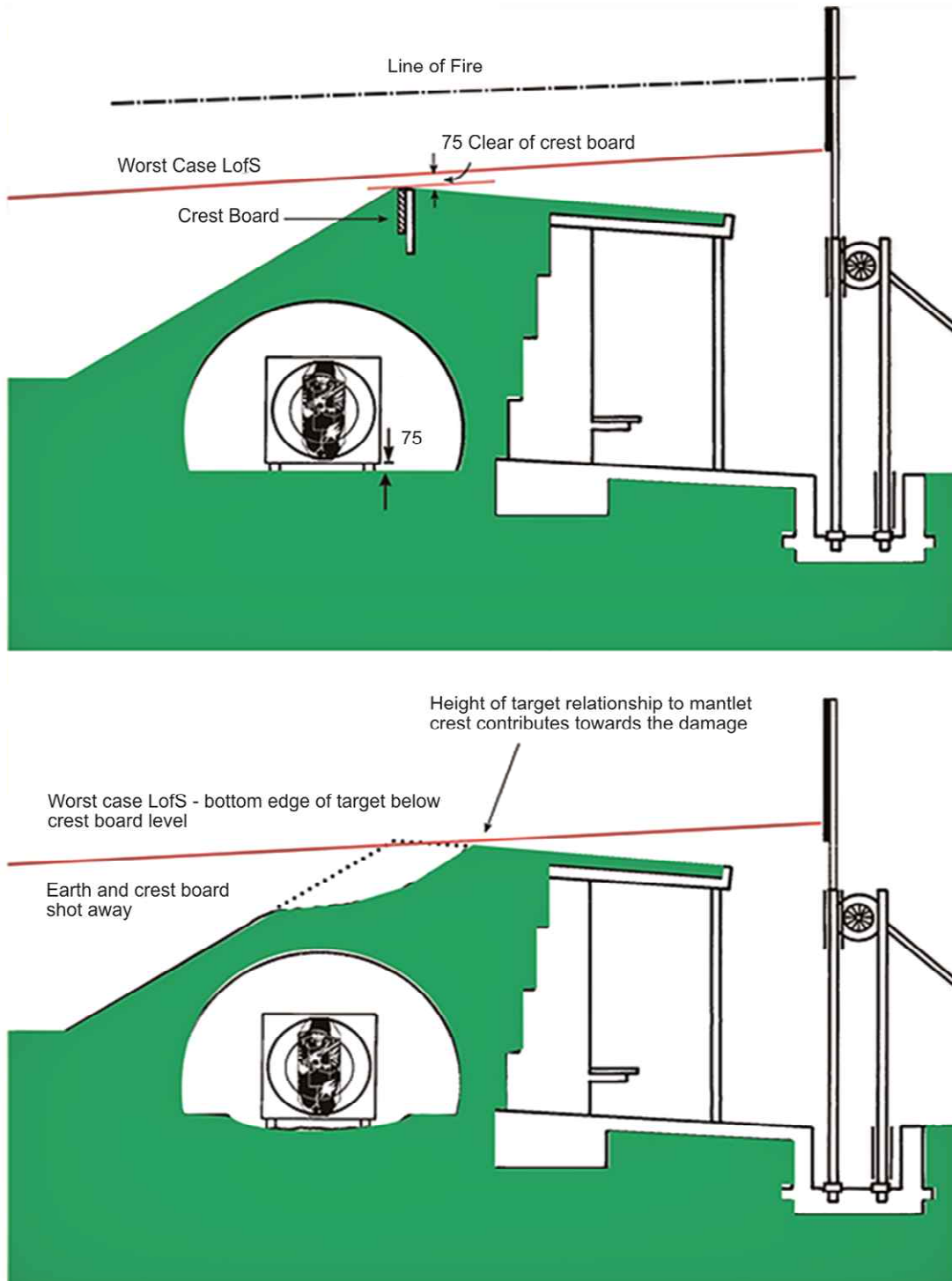

Fig 11 - 11. Crest Board Clearance and Mantlet Damage

All dimension in millimetres unless otherwise stated

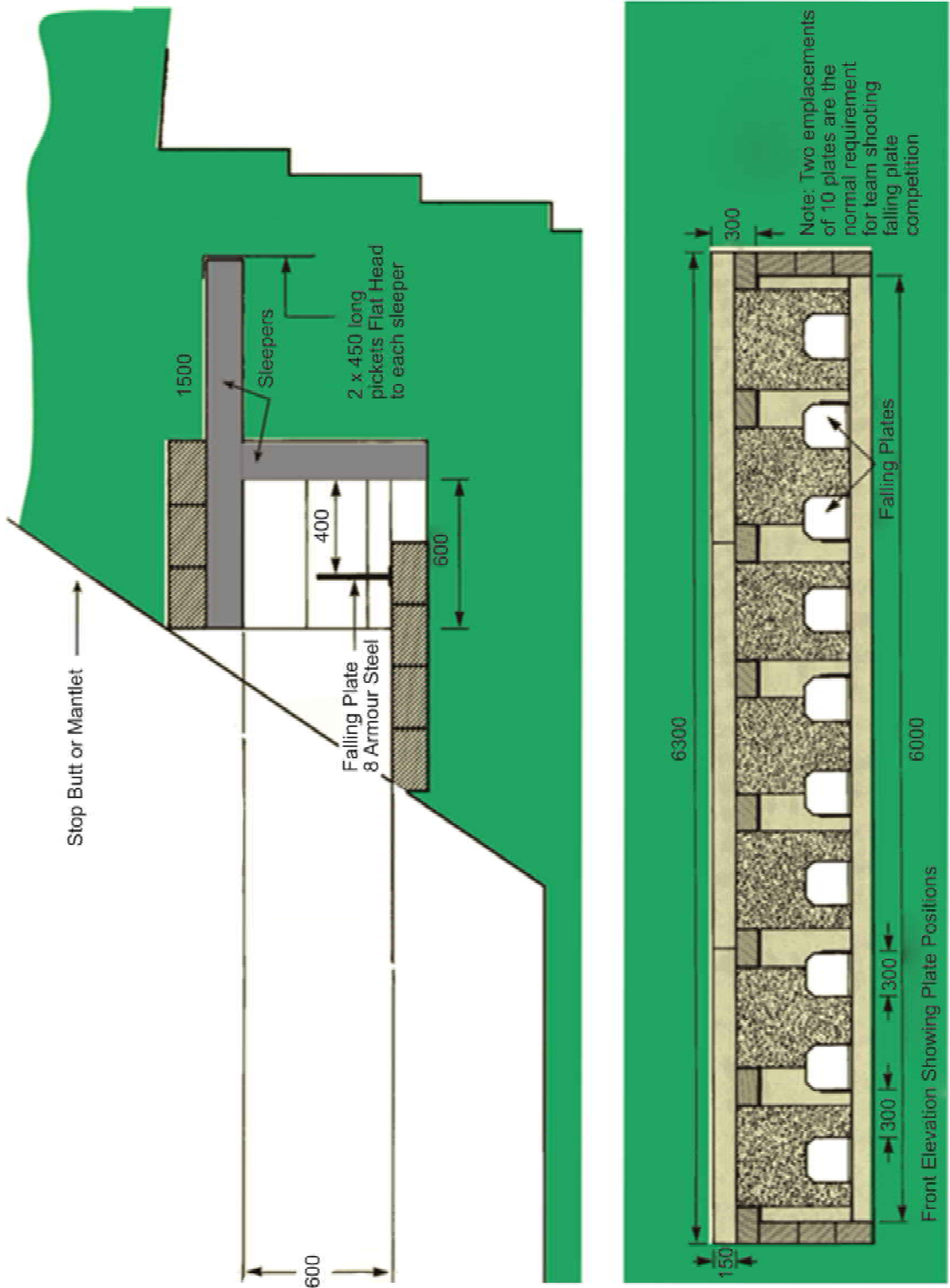

Fig 11 - 12. Shooting-in Boxes

Shredded rubber blocks provided where excessive mantlet attrition occurs. Rubber slabs are bonded and bound together to achieve required thickness.

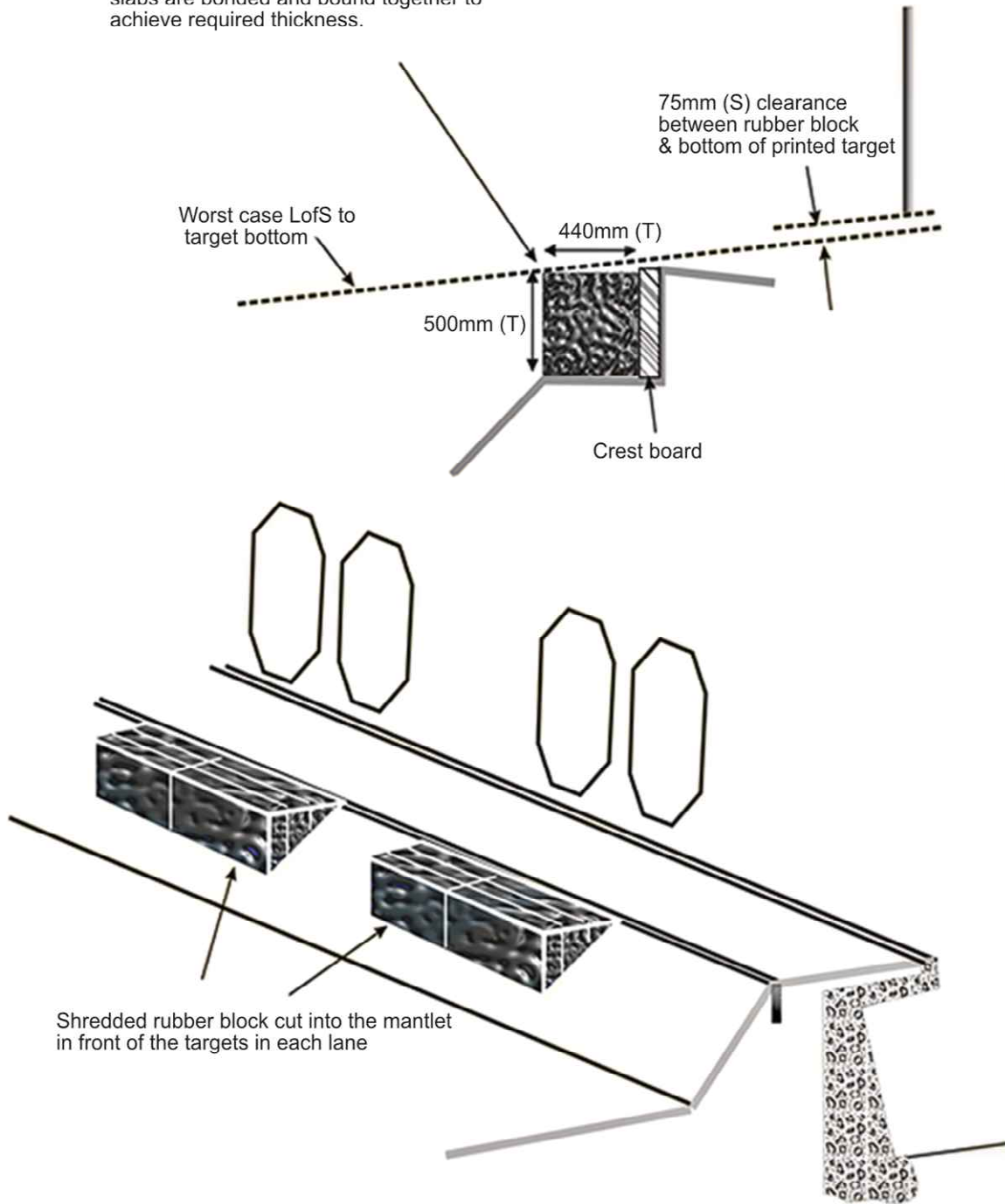

Fig 11 - 13. Mantlet Protection Options for Ease of Maintenance

Chapter 12 - The Converted Gallery Range and Electric Target (Limited Danger Area) Range (Read in conjunction with Chapter 11)

Converted Gallery Range (CGR) is a Gallery Range that has been converted to be equipped with Fixed Electric Targets (FET), each of which provide two 'fall-when-hit' targets per shooting lane (target details are given in Chapter 24). A new build range with Hythe frames and FETs is also referred to as a CGR. If the mantlet is constructed as shown in Fig 12 - 2, an Automatic Marking System (AMS), such as SARTS may be installed, potentially, without further major works. When a new range is constructed without a gallery but with FET, it is termed an Electric Target (Limited Danger Area) Range (ET(LDA)R). The CGR and ET(LDA)R can be used to fire the same SA as the GR using the Gallery RDA template. This chapter describes the construction requirements to convert a GR to a CGR and the construction of a new ET(LDA)R. The features which do not differ from the GR are not covered in this Chapter and for which reference should be made to Chapter 11.



Conversion Construction

General

12-01. **Design Considerations.** No range design work should start until full details of the targetry to be used are to hand. Compliance cannot be achieved without full details of the targets and target mechanisms. The firing point crest board, mantlet crest board, stop butt and target centres are all linked in the design to achieve compliance. Ranges with FET and AMS will require different design detailing to those ranges without AMS due to differing target requirements.

12-02. **Land Requirements.** The construction of a new CGR or ET(LDA)R may be more expensive than an ETR. Considerations such as land availability may, however, make the ET(LDA)R the preferred choice. A comparison of the land requirement is:

- a. **CGR, ET (LDA)R.** Length 2400m, width 750m and an area of 1,800,000m² (180 hectares or 445 acres).

- b. **ETR.** Length 3325m, width 1132m and an area of 3,763,900m² (376 hectares or 930 acres).

12-03. **Conversion.** The conversion of a GR to a CGR requires that all elements of the range be brought up to full metric GR specification. The designer / contractor must establish the current range profile and layout in relation to compliance prior to conversion. Ranges with firing points set out in imperial should be converted to metric. By installing FETs on the mantlet of a GR the GR RDA will increase in width due to re-alignment of LoS to target centres. To facilitate AMS, it will be necessary to ensure the LoS for each firing position is as close to perpendicular to the targets as is practical. Conversion will include:

- a. Reconstruction of the mantlet and installation of FET.
- b. Realignment of lanes if necessary.
- c. Construction of the control building.
- d. Installation of electric power and target control circuits.
- e. It is most likely that there will be an increase to the stop butt dimensions if mantlet height changes or firing points are taken back to metric distances.

12-04. **Layout for an Automatic Marking System.** AMS often requires precise range layout to assure accuracy in recording the fall of shot. If firing lanes are re-aligned the RDA must be reconfirmed. When converting to an AMS, careful design is required to ensure full target exposure with clearances. If AMS is to be installed either at the time of conversion or later and for new ranges refer to RITT for details of current AMS installation requirements.

Mantlet

12-05. **General.** The reconstruction details for the mantlet are shown in Fig 12 - 2. Any elements of the existing mantlet that are to be retained are to be assessed to ensure that they are structurally sound and can withstand loads imposed by the new design before work commences. The depth from the markers' gallery to the mantlet crest board must be able to accommodate the target system and access path. The face profile of the mantlet is retained at the recommended 34⁰ (S) (2:3) from the horizontal whilst the full face at minimum height of 2m (C) must remain visible to the firer from all firing points. Extending the mantlet by filling on to the existing construction is not good practice. The mantlet should be totally reconstructed as a monolithic structure of fully compacted appropriately layered of stone-free soil, which should ensure that there is no settlement under the additional imposed loading. A rock core is permitted but this must be covered and faced with stone-free soil to a minimum depth of 1000mm (C), parallel to the line of fire, on the front face. In accordance with Health and Safety at Work Regulations, protection should be provided where there is a drop into the gallery. To avoid the fall from height hazard when working on the mantlet on a CGR it is possible to provide the access path in front of the mantlet, see Fig 12 - 2, though this may introduce potential maintenance issues of its own.

12-06. **LoS Clearance.** The slope from front to back on top of the mantlet is dependent upon the levels on the range floor, and particularly the level of firing point crest boards. It is important that at the design stage the following clearances are resolved to ensure full target exposure and clearances. (Note: With current FETs it may not be possible to achieve all clearances).

- a. FET clearance 50mm (C) below the lowest LoS.
- b. Bottom of target 75mm (S) from highest LoS.
- c. No ricochet inducing surfaces from any LoS.
- d. Gallery frames clearance 75mm (C) below the lowest LoS.

Stop Butt

12-07. **General.** Generally, converting a gallery range will require an increase in the height of the stop butt. Existing Imperial Gallery Ranges have a 1.8m mantlet and the stop butt is determined with a 3.05m pole set on the mantlet crest board. Conversion is to bring the mantlet height up to at least 2.0m (C) and a 5.0m (C) pole set on the mantlet crest board is to be used to determine the increased stop butt height required.

Targetry

12-08. **Targets.** Only authorised targets described in Chapter 24 may be used. All targetry is to comply with paragraph 12-06. Falling plate targets may be used with the same conditions and limitations applicable to the GR. See Pamphlet 21 for details of falling plate practices.

12-09. **Fixed Electric Target Locations.** The FET consist of 24 units, 2 for each of the 12 lanes (see Fig 12 - 1). Each unit is normally housed in a pre-cast concrete box (coffin). It is often necessary to enclose coffins with vandal-proof lids. The coffins in each pair are set slightly staggered to allow their lids to open without obstruction; coffins with single lids need not be offset. However, each coffin must be placed symmetrically across the centre line of the firing lane to facilitate AMS.

12-10. **Protection.** Coffins are protected against strike typically by earth / timber / rubber block and backed by 12mm thick armoured steel sheet to the specification provided in Chapter 2 (see Fig 12 - 2). Note that the steel is not to be exposed to strike as otherwise it is a hard surface and will create a backsplash and ricochet hazard. Depending on site conditions, all elements must be set to a level so that no part is above the line from the mantlet crest at a fall of 4.85° (1:12) from the worst case LoS. In addition, it is necessary to ensure that no part of the coffin is exposed to the firer standing on any firing point. A minimum 50 mm (C) margin for safety is to be provided between the worst LoS and the highest part of the coffin (see Fig 12 - 2).

12-11. **Target Store and Workshop.** Extra space is likely to be required in both the target store and workshop to accommodate an increased holding of targets for FET. It may be possible to turn the existing workshop into an extra target store and to build a new workshop behind the range. Roller tables or lifting gear should be provided to move FETs within the workshop. The workshop must be large enough to allow for:

- a. Storing spare FET and spare parts.
- b. Repairing and servicing FET.
- c. A 240volt AC power supply.
- d. Working space for 3 men.

Control Building

12-12. **Purpose.** This building houses the control, operation and communication systems required to control the range, activate the targetry and record the number of hits. It is an operations room which should be sized only to accommodate personnel essential to running practices.

12-13. **Location.** The control building is usually sited to the right, rear of the 300m firing point at an angle optimising the view of the range (see Figs 12 - 1 and 12 - 2). However, where the targetry system can be operated from the range floor the control building may be located anywhere on the range, preferably outside of the template.

12-14. Construction.

a. Where the control building is located within the danger area template. The walls may be constructed of concrete or brick. The walls exposed to strike must provide ballistic protection and prevent damp entering where earth banks are used. The protected walls will also need to be designed to withstand lateral pressures where earth or sand banks are used. The back wall facing 400 - 600m firing points is constructed to withstand bullet penetration (See Chapter 2). The rear of the building must be faced so that firers are not exposed to the risk of backsplash (Note. 7.62mm tracer may backsplash 125m from large sand banks with 34° slopes). On compacted earth slopes the 7.62mm tracer rounds are normally captured without ricochet. If earth or sand banks are not used, anti-splash protection is provided with 50mm timber boarding on 50mm timber battens set vertically to cover the walls exposed to strike. The timber protection is to be offset to allow inspection of the protected walls for shot damage or fixed in such a way to allow inspection of the wall. The building has a raised floor to give the equipment operators a clear view of the targets over the heads of personnel on the firing point. The building should be vandal-proof.

b. Where the control building is located outside of the danger area template. The building may be constructed of any suitable material. It is not required to be impenetrable to shot, nor will it require protecting for ricochet and back splash. Where the building is located alongside a firing point, but outside of the template, consideration is to be given to persons entering or exiting the building causing a distraction to firers on rearwards firing points.

12-15. Warning Flags and Lights.

a. **Range In Use Flag / Lights.** The range in use flag / light is to be located as described in Chapter 2. Traditionally the range in use flag / light was mounted on the control building at the furthest safety point from the access door.

b. **Control Building Flag.** Where a control building is located inside the DA a flagpole, made of non-backsplash inducing material, is provided, and used in a similar way to that on a mantlet for a butt party. This pole is for hoisting a red flag as an emergency warning system. A red light operated from the control building is fitted to the top of this flagpole for night firing.

Electricity Supply

12-16. **Electricity Supply.** The provision of a reliable supply of electricity is essential. The power requirement to successfully use a CGR or ET(LDA)R will vary with the

circumstances of each range but, as a guide, 50kilovolt Amperes Triple Phase and Neutral (50kVA TP&N) is generally satisfactory but a generator seldom is. In addition to electricity for target mechanisms and control circuits, power should be provided to heat and light:

- a. Control building and systems.
- b. Range Wardens' workshop.
- c. Target store.
- d. Troop shelter and toilets.
- e. Night firing warning lights.

12-17. **Fixed Electric Target.** The power supply to FET should be switched and circuit protected. The switch should be a lockable isolator switch to prevent others accidentally turning on the power while work on FET is undertaken.

Communications

12-18. **External.** A means of summoning the emergency services, ideally a land laid telephone is to be available.

12-19. **Internal.** A method of connecting the control building to the RCO, troop shelter, butts and target line is required.

12-20. **Public Address System.** A PA system may be required with a microphone in the control building. Loudspeakers are to be located, as required, to ensure that they can be heard from any location on the range.

12-21. **Protection.** The down-range telephone connection points, if fitted, must be protected against SA fire by timber 100mm thick or 500mm of well compacted soil. All cables are to be buried in protective conduit with waterproof connections and fittings (see Chapter 11). The connection point is to be to the rear of their respective firing points.

Maintenance

12-22. **Responsibilities.** The requirements for maintaining a GR (see Chapter 11) apply equally to the CGR and ET(LDA)R. Maintenance of the range is the responsibility of the RAU and may be divided as follows:

- a. **Range Warden.** See DSA 03.OME Part 3 Volume 1 Part 2.
- b. Property Management.
 - (1) Grounds.
 - (2) Fencing and sign posting. (See Chapter 2).
 - (3) Structures, roads and drainage including stability of slopes and erosion control.
 - (4) Water and electricity supplies.
 - (5) Periodic refurbishment of the range structure.

- c. **Equipment Management.** Repairing and servicing equipment installed by Single Service contract.

12-23. **Frequency.** Proper maintenance depends on good liaison between the Range Warden and the RAU, and properly scheduled maintenance periods. A heavily used range may need one day's maintenance each week plus one- or two-days' maintenance by the Range Warden each month. Two closed periods of a week or so may be needed each year for repairing buildings and earthworks; this work should be combined with contract repair of equipment.

Compliance Checks

12-24. The compliance checks are detailed below:

- a. Authorised weapons, ammunition, and practices.
- b. Firing point type, dimensions, construction, lane identification, alignment, and profiles.
- c. Visibility of required mantlet face from all firing points.
- d. Mantlet profile, height, and width.
- e. Full exposure of all targets from all firing points, spacing, identification and target centre height.
- f. Minimum clearance over mantlet crest board.
- g. Protection to coffins and minimum clearance over coffin.
- h. Minimum clearance over Hythe Frame (where provided).
- i. Stop butt alignment, distance from target line, size, and profile.
- j. Falling plate target position and construction, if applicable.
- k. Positioning, alignment, and protection to control building.
- l. Quadrant Elevation to target centre. (CoF then added to determine max QE).
- m. Template alignment.

All dimensions in metres unless otherwise stated

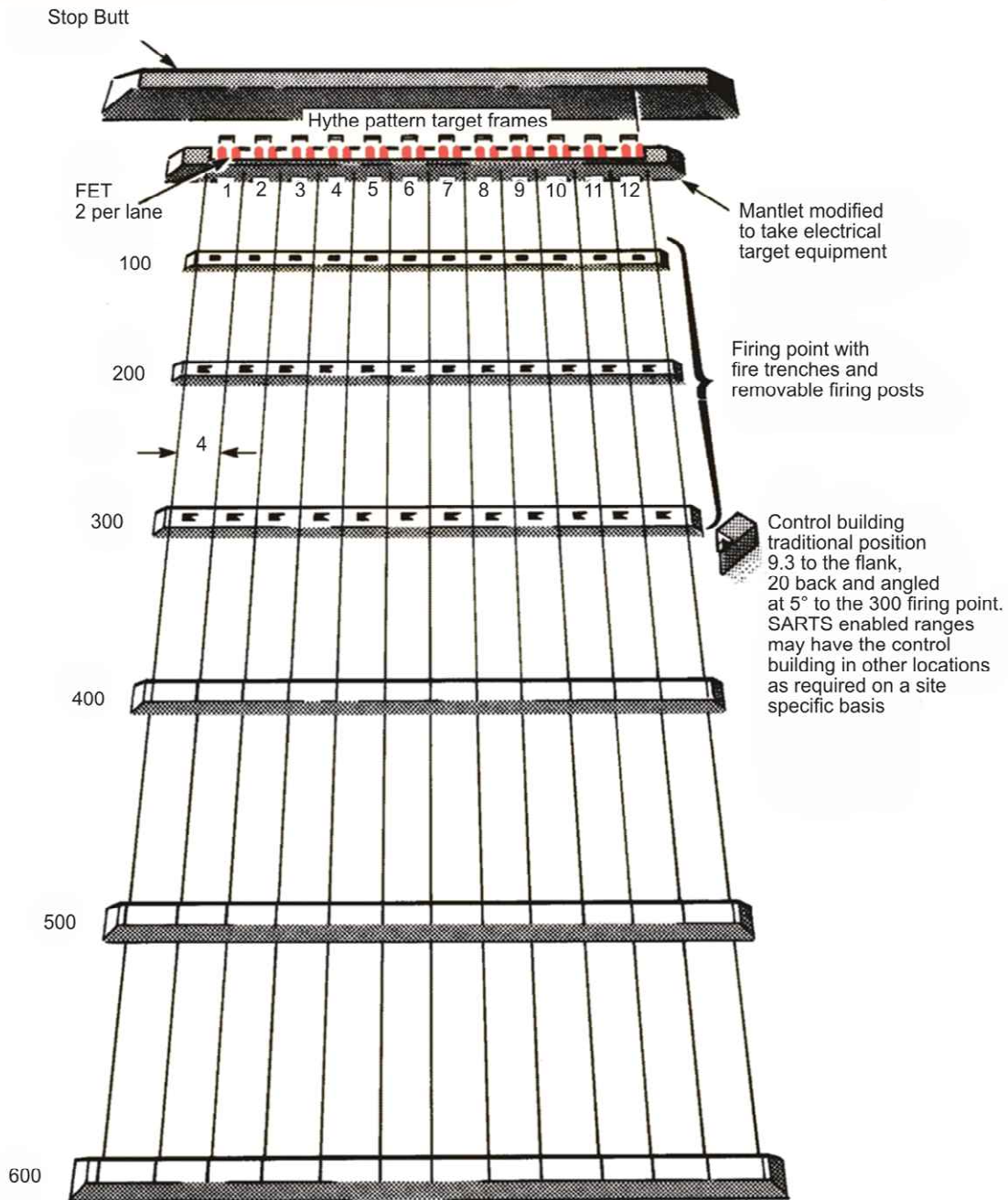

Note: Double targets for GPMG positioned between the two lanes with targets in the right hand FET of the left lane and the left hand FET on the right lane.

Fig 12 - 1. Layout CGR

All dimensions in millimetres unless otherwise stated

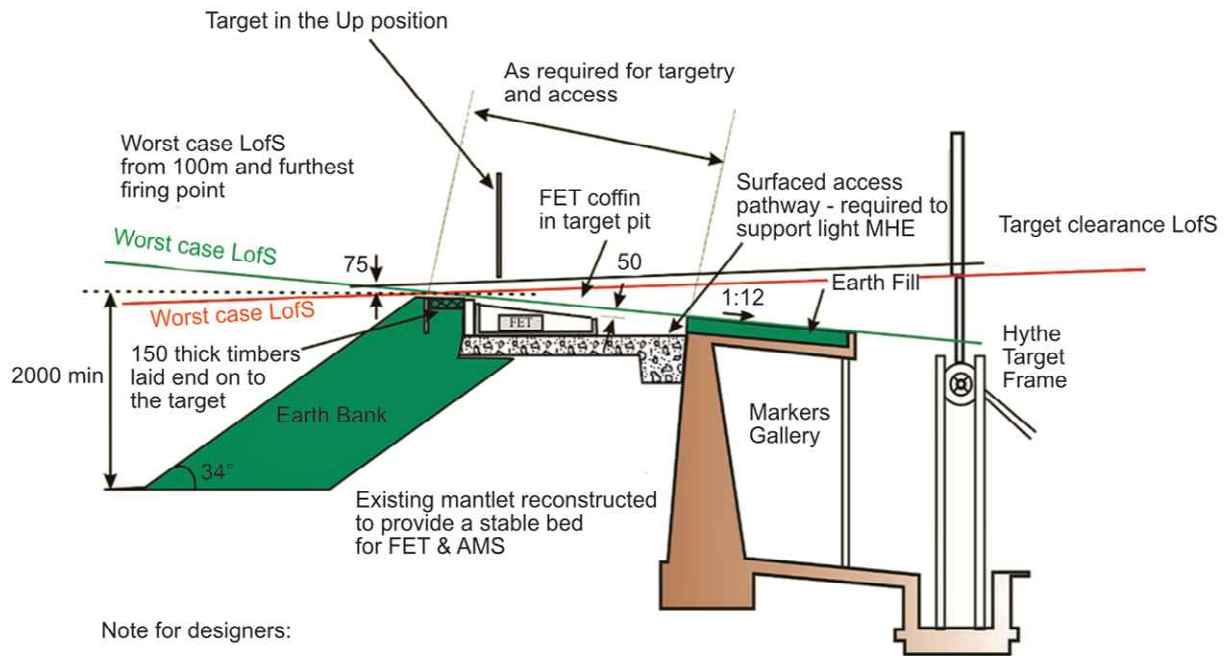

Note for designers:

1. Clearance cannot be achieved without full targetry details.
2. Target positions for FET and FET with AMS are different.

Section of Reconstructed Mantlet FET & AMS

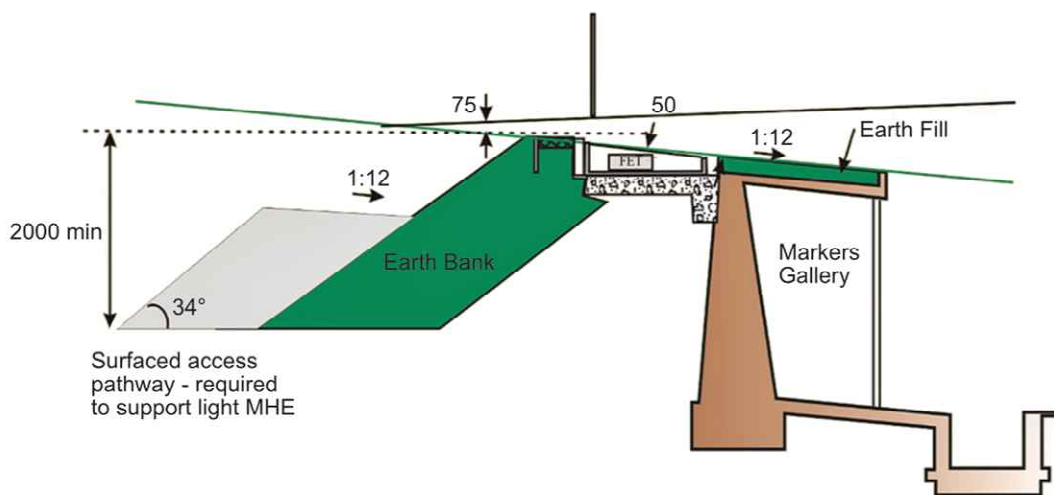

Alternative Section of Reconstructed Mantlet Showing Front Access Path

Fig 12 - 2. Siting of FET and Access Path

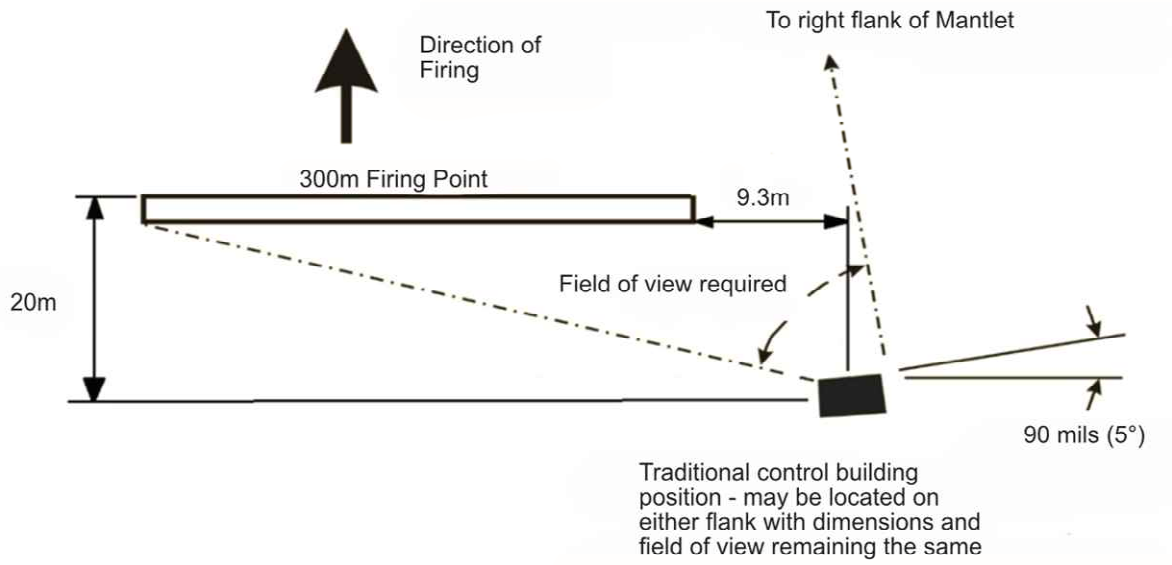

Fig 12 - 3. Siting of a Control Building

Chapter 13 - The Electric Target Range

Range

The standard Electric Target Range (ETR) has a main firing point and three rows of electrically operated targets at 100, 200 and 300m from the main firing point. Three further firing points are provided at 100m intervals behind the main firing point (400, 500 and 600m). On ranges where there is insufficient land behind the main firing point, the 400m target line may be inserted in front of the main firing point. Target mechanisms are FET (see Chapter 24). A separate Grouping and Zeroing range (G&Z) is normally provided. A typical ETR is illustrated in Fig 13 - 1.



13-01. **Purpose.** The ETR is designed for a fast throughput of troops firing most types of SA and being trained in the application of fire required by the Operational Shooting Policy. Grouping and zeroing may be conducted though this will require modification to the standard design.

Danger Areas

13-02. **Danger Area.** The RDA template for an ETR is shown in Fig 13 - 2. The area is based on the WDA template for 7.62mm and 5.56mm centrefire rifle ammunition and is applied from all firing points.

13-03. **Hard Surfaces, Hard Targets.** Where hard surfaces exist or when hard targets are engaged, the hard target template wings are to be applied (see Fig 15 - 2).

13-04. **Use of Pistol on ETR Ranges.** Where pistols are fired on an ETR the pistol template (135mils) may fall beyond the ETR template on the left and right flank. Advice from RITT is to be sought.

Design

13-05. **Design.** Design and construction details are available from RITT. The range layout is shown in outline in Fig 13 - 1.

13-06. **Siting.** The site selected for an ETR should be as flat as possible to reduce the requirement for earthworks to a minimum and ensure that the QE remains within the limit of 150mils. A slightly concave site with the lowest point between the main firing point and the 400m firing point is advantageous. A northerly direction of fire will provide the best light for daytime shooting. However, local population density should not be forgotten and,

where possible, the range should be orientated accordingly. The range floor is to be well drained with streams or drainage ditches being routed through culverts to allow the safe movement of troops down the range as advancing down the range between firing points is required.

13-07. **Co-located Grouping & Zeroing Range.** A G&Z range ideally should be co-located adjacent to a ETR. When space restrictions allow no alternative, the G&Z range may be superimposed on the ETR. However, the G&Z range must not be used when firing takes place from the rear of the main ETR firing point unless it is located outside the ETR DA.

Construction

General

13-08. **Principle.** As all ETR are FDA ranges, there is no need for a stop butt to capture shot or ricochet off the range floor. However, an environmental bank may be required subject to the findings of a Land Quality Assessment (LQA).

13-09. **Dimensions.** The range with its RDA will occupy a substantial part of a training area. The total length of 3325m with an average width of 1132m covers an area of 3,763,900m² (376 hectares or 930 acres).

Target End

13-10. **Mantlets.** Where Fixed Electric Targets (FET) are ground mounted protective mantlets are required. The mantlets must be fully compacted to prevent settlement and exposure of the FET. The mantlet is between 300 and 500mm high and may be individual to each FET or continuous across the width of the range. It is desirable that the whole target is visible to the firer in the prone posture (current FET systems may not achieve full visibility) and that no part of the target mechanism is visible to the firer standing at any point of engagement. The surface is to be grassed to make it stable and prevent erosion or stabilised with low maintenance materials that help stem attrition. A crest board, typically of 150 x 25mm timber, set into each mantlet will assist in retaining the profile.

13-11. **Targetry.**

- a. **Fixed Electric Target Equipment.** FET in their coffins is positioned one per lane at the 100, 200 and 300m target lines and each is protected by a mantlet (see Fig 13 - 4) or cut into the ground. They are positioned in each lane so that the targets at 100 and 300m are on the lane centre line. The targets at 200m are off set 2m to the left of the lane centre line to aid visibility. The whole target should be visible to the firer from the prone posture and no part of the target mechanism is to be visible to the firer standing at any point of engagement.
- b. **Access.** An access path wide enough for an FET trolley is built to the rear of the FET pits. An area on each side of the coffin is levelled and surfaced typically with gravel to give access to the equipment and space for the mild steel coffin lids to open below the LoF.
- c. **Targets.** Fig targets, FET and AMS are described in Chapter 24. The most used targets on an ETR are aluminium or plastic Figs 11 and 12. Representative targets may be produced locally using plywood veneers and various facings. Such

targetry must be light, have low wind resistance and be no larger than a triple Fig 11 target.

Range Floor

13-12. **Ease of Movement.** The range floor between the firing points and up to 25m forwards of the 100m target line must allow safe fire and movement. The closest engagement distance is usually 25m forward of the 100m target line enabling firers to engage the 200m targets from 75m. The Limit of Advance must be clearly identified. Note that the Limit of Advance may be reduced if there is not sufficient room to fit the template in the available land. It is essential that no part of the target mechanism is exposed to strike from any firing position.

13-13. **Range Steps.** A cross-fall on the range floor may require steps to be constructed between lanes. The width of each step is additional to the lane width and will increase the overall range width.

13-14. **Lane Marking.** Each lane is to have its lane number clearly marked on each firing point, ideally located centrally within lane. To ensure that firers engage the correct target and avoid cross-lane firing, timber lane marker posts are positioned on the flank of each firing lane forward of the 100 and 200m target lines. The posts are typically a short black one on one side of the lane and a tall red post on the other, alternating across the firing point. The colours may be altered to contrast with the terrain colouration. Posts may be also fitted at the 300m target line if required. Historically posts with black and white bands were used, however these are to be replaced with the current standard when they require refurbishing. The firing points are also to have their lane extents clearly marked; this may be with posts like those on the target lines.

Control Building

13-15. **Purpose and Location.** On existing ranges, the control building often was positioned centrally 8m behind the main firing point. On new ranges it is to be positioned on one flank (see Fig 13 - 1) or to the rear of the range, ideally outside of the danger area template. The building houses the range control and communication systems to activate the targetry and record the number of hit and when located down range it provides protection to the personnel in it. The control building is an operations room that should be sized to accommodate the personnel essential to control and operate the equipment. Ranges equipped with an AMS may require a revised layout to provide secure storage facilities and additional environmental controls.

13-16. **Construction.** The control building walls may be constructed of concrete, solid block or brick when located down range and from any suitable material when sited at the back of the range. The walls exposed to strike must provide ballistic protection and prevent damp entering where earth banks are used. The protected walls will also need to be designed to withstand lateral pressures where earth or sand banks are used. The back wall facing 400 - 600m firing points is constructed to withstand bullet penetration (See Chapter 2). The rear of the building must be faced so that firers are not exposed to the risk of backsplash (Note. 7.62mm tracer may backsplash 125m from large sand banks with 34° slopes but is contained in earth banks of 34° or more). If earth or sand banks are not used, anti-splash protection is provided with 50mm timber boarding on 50mm timber battens to cover the walls exposed to strike. The timber protection is to be off set to allow inspection of the protected walls for shot damage or fixed in such a way to allow inspection of the wall. The building has a raised floor to give the equipment operators a clear view of

the targets over the heads of personnel on the firing point. The building should be weather tight and vandal-proof.

13-17. **Installations.** An automatic target system may be installed to automate practices. Space should also be allowed for AMS control and recording equipment. For night firing, warning and night visibility internal lighting will be required.

13-18. **Warning Flags and Lights.**

a. **Range in use Flag / Lights.** The range in use flag / light is to be located as described in Chapter 2. Traditionally the range in use flag / light was mounted on the control building at the furthest safety point from the access door.

b. **Control Building Flag.** Where a control building is located inside the DA a flagpole, made of non-backsplash inducing material, is provided, and used in a similar way to that on a mantlet for a butt party. This pole is for hoisting a red flag as an emergency warning system. A red light operated from the control building is fitted to the top of this flagpole for night firing.

Firing Points

13-19. **Main Firing Point.** The main firing point of a standard range has 12 firing lanes, each of which is provided with a fire trench, firing post and a surfaced area, refer to paragraph 2-81 (including sub-paras). Firing point surfaces may be constructed with any low maintenance surface providing it will not present a hard ricochet. It is to be noted that the firing post and trench clearly define the extents of the firing point so, in terms of markings, only require a lane number.

13-20. **Other Firing Points.** The 400 to 600m firing points are typically grassed earth banks high enough for the prone firer to see the whole target at all three engagement distances. If the lane extents are marked by pegs these must be consistent across the whole firing point with it clearly expressed in Range Standing Orders which side of the peg the firer is to fire from. Refer to paragraph 2-81 (2) for crest boards on earth firing points. Additional firing points are provided 50m forward of the main firing point marked on the range floor with lane and distance markers. See Fig 13 - 1.

13-21. **Alignment.** The centre line of each firing lane is parallel to the main axis of the range. If any firing point requires to be built-off centre, the DA will be increased.

13-22. **Fire Trenches.** The trenches may be timber revetted or pre-cast concrete sections with a timber surround at the top to prevent ricochet (refer to Chapter 2), Provision should be made for drainage. In areas of high-water table, it may not be practical to provide fire trenches. The forward edge of the trench is set back 450mm from the crest board to ensure that the muzzle of a rifle clears the crest. Where the local risk assessment determines a potential hazard such as animals or children accessing the range when not in use, lids to cover the trench should be considered. Where trench covers are not suitable, warning signs around the area should be provided.

13-23. **Firing Posts.** These are typically 100mm (T) x 100mm (T) and are 1200mm (S) high, measured from the top of the firing point crest. The depth below ground will need to be determined to suit the site-specific fixing method but the post is to be suitably held in place so that it offers support and does not move excessively when leant upon.

Electricity Supply

13-24. **Electricity Supply.** The provision of a reliable electricity supply is essential (a generator seldom proves satisfactory). The power requirement to successfully use a range will vary with circumstances but, as a guide, 50kVA TP&N is generally satisfactory. In addition to electricity for target mechanisms and control circuits, power should be provided to heat and light:

- a. Control building and systems.
- b. Range Wardens' workshop.
- c. Target store.
- d. Troop shelter and toilets.
- e. Night firing warning lamps.

13-25. **Fixed Electric Targets.** Power supply to FET should be switched and circuit protected. The switch should be a lockable isolator switch to prevent others accidentally turning on the power while work on the FETs is undertaken.

Communications

13-26. **External.** A means of summoning the emergency services, ideally a land laid telephone is to be available.

13-27. **Internal.** A method of connecting the control building to the RCO, troop shelter, and target line (for testing purposes) is required.

13-28. **Public Address System.** A PA system is required with a microphone in the control building. Loudspeakers are to be located, as required, to ensure that they can be heard from any location on the range.

Maintenance

13-29. **Responsibilities.** The maintenance commitment on a ETR is not as demanding as ranges with a stop butt. However, mantlets protecting target mechanisms must be carefully maintained, and FET will require checking and changing (a two-man lift). General maintenance of the range is the responsibility of the RAU and may be divided as follows:

- a. **Range Warden.** See DSA 03.OME Part 3 Volume 1 Part 2.
- b. **Property Management.**
 - (1) Grounds.
 - (2) Fencing and sign posting (See Chapter 2).
 - (3) Structures, roads, and drainage including stability of slopes and erosion control.
 - (4) Water and electricity supplies.
 - (5) Periodic refurbishment of the range structure.

- c. **Equipment Management.** Repairing and servicing equipment installed by Single Service Contract.

13-30. **Frequency.** Proper maintenance is dependent upon good liaison between the Range Warden and the RAU, and on properly scheduled maintenance periods. A heavily used range may need one day's maintenance each week plus one- or two-days' maintenance by the Range Warden each month. Two closed periods of a week or so may be needed each year for building and earthworks repair; this work should be combined with the contract repair of equipment.

Compliance Checks

13-31. The following should be checked.

- a. Authorised weapons, ammunition, and practices.
- b. Firing point type, dimensions, construction, lane identification, alignment, and profiles.
- c. Full exposure of targets from all firing points, spacing of targets.
- d. Protection to coffins and minimum clearance over coffin.
- e. 200m target line offset and limit of advance identification.
- f. Positioning, alignment, and protection to control building.
- g. Quadrant Elevation (150mils).
- h. Template alignment.

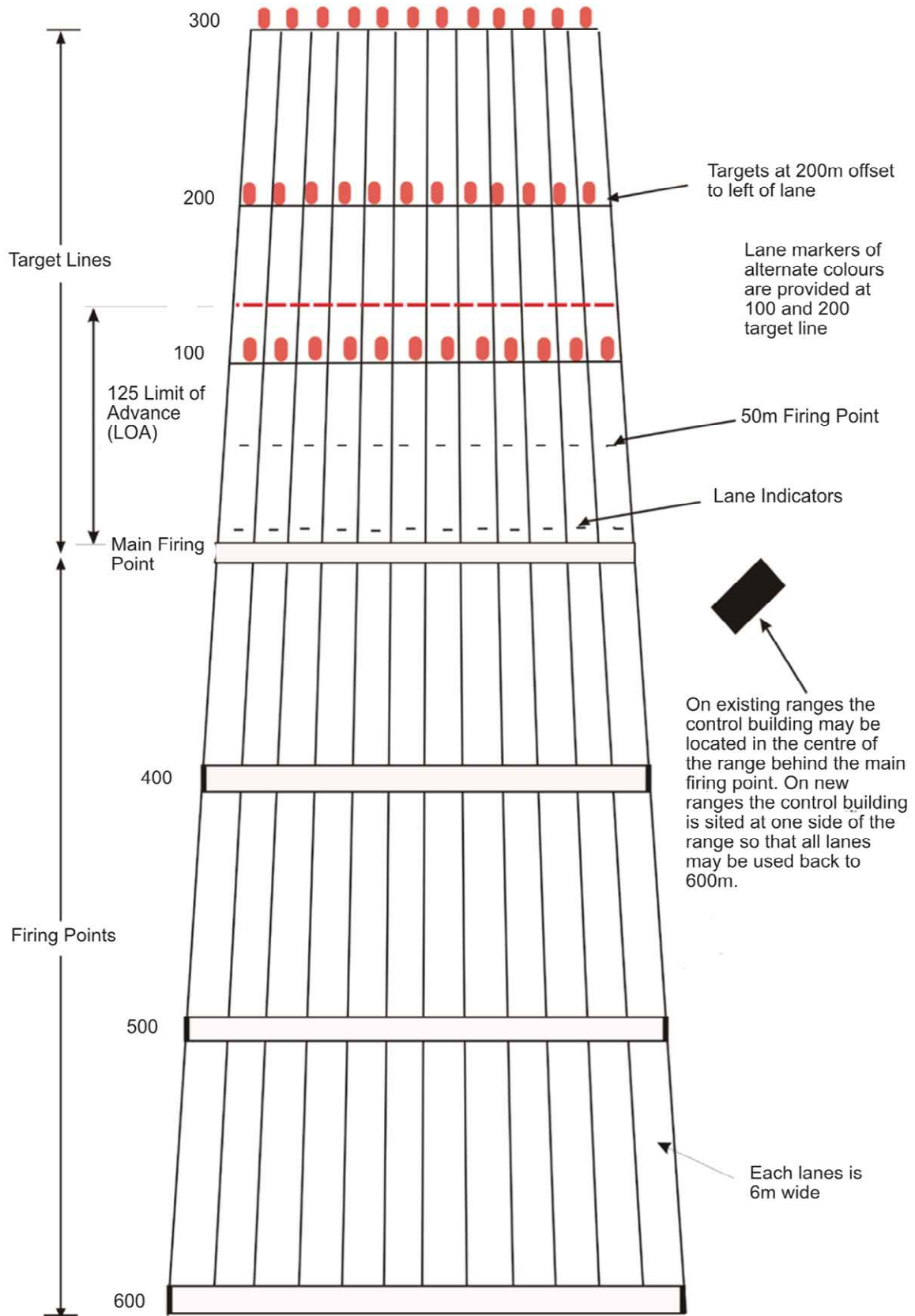
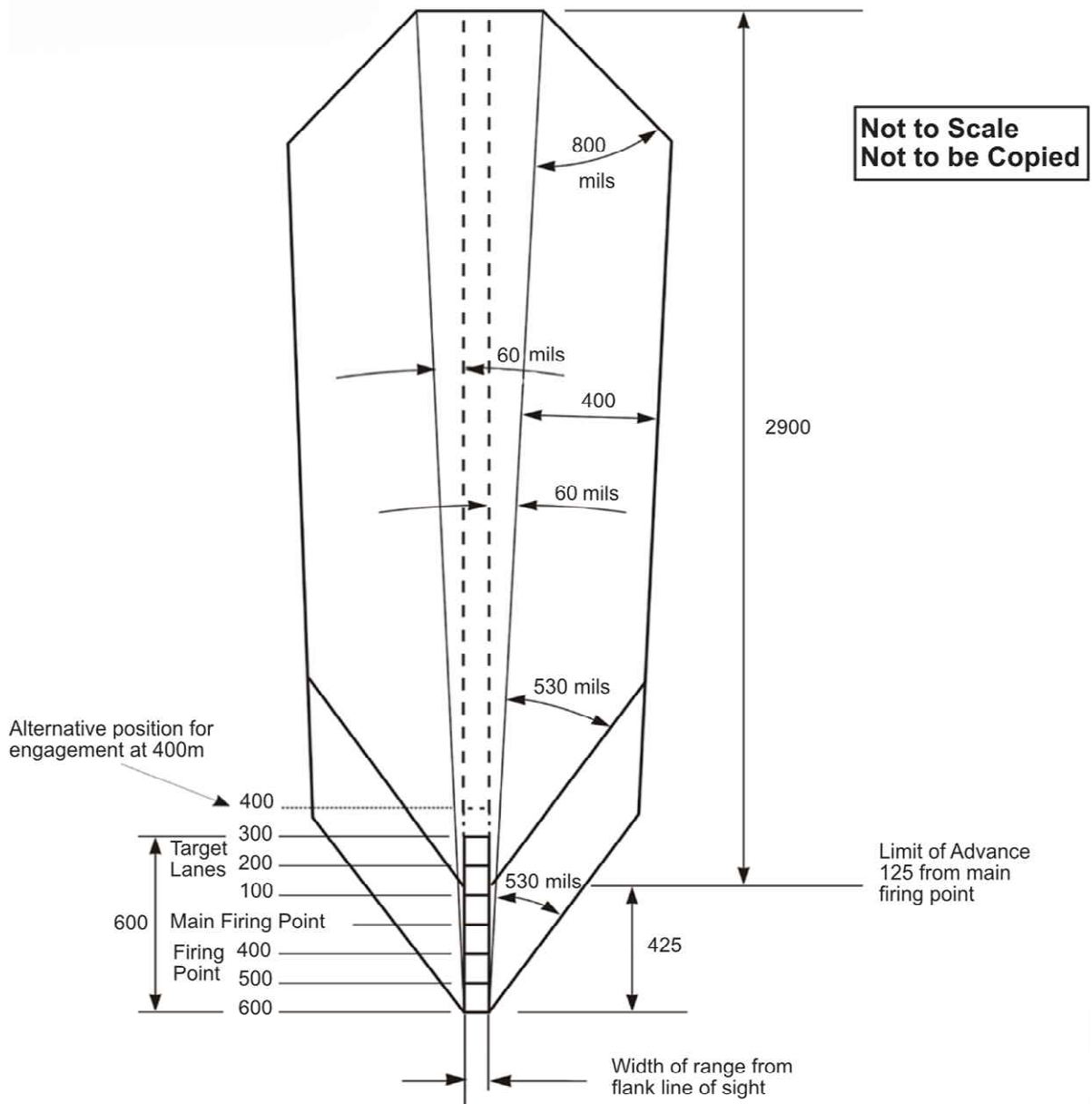

Fig 13 - 1. ETR Layout

All dimension in metres unless otherwise stated



Notes:

1. ADH: 5.56mm and 9mm: 500ft, 7.62mm Ball 750ft, 7.62mm Tracer 1500ft.
(For ranges where the range floor is not shaped use LFTT ADH details in Chap 2, Table 2-1)
2. When firing 7.62mm Ball an Air Sentry may be required.
3. For pistol use see para 13-4 and Ref B (Pamphlet 21).
4. Where unprotected hard surfaces exist on the range floor within the CoF, hard template wings are to be applied.
5. The template is asymmetrical due to the 200m target line offset.

Fig 13 - 2. RDA Template, QE <150mils – ETR (RDA for 5.56mm and 7.2mm Service Ammunition shown)

All dimension in metres unless otherwise stated

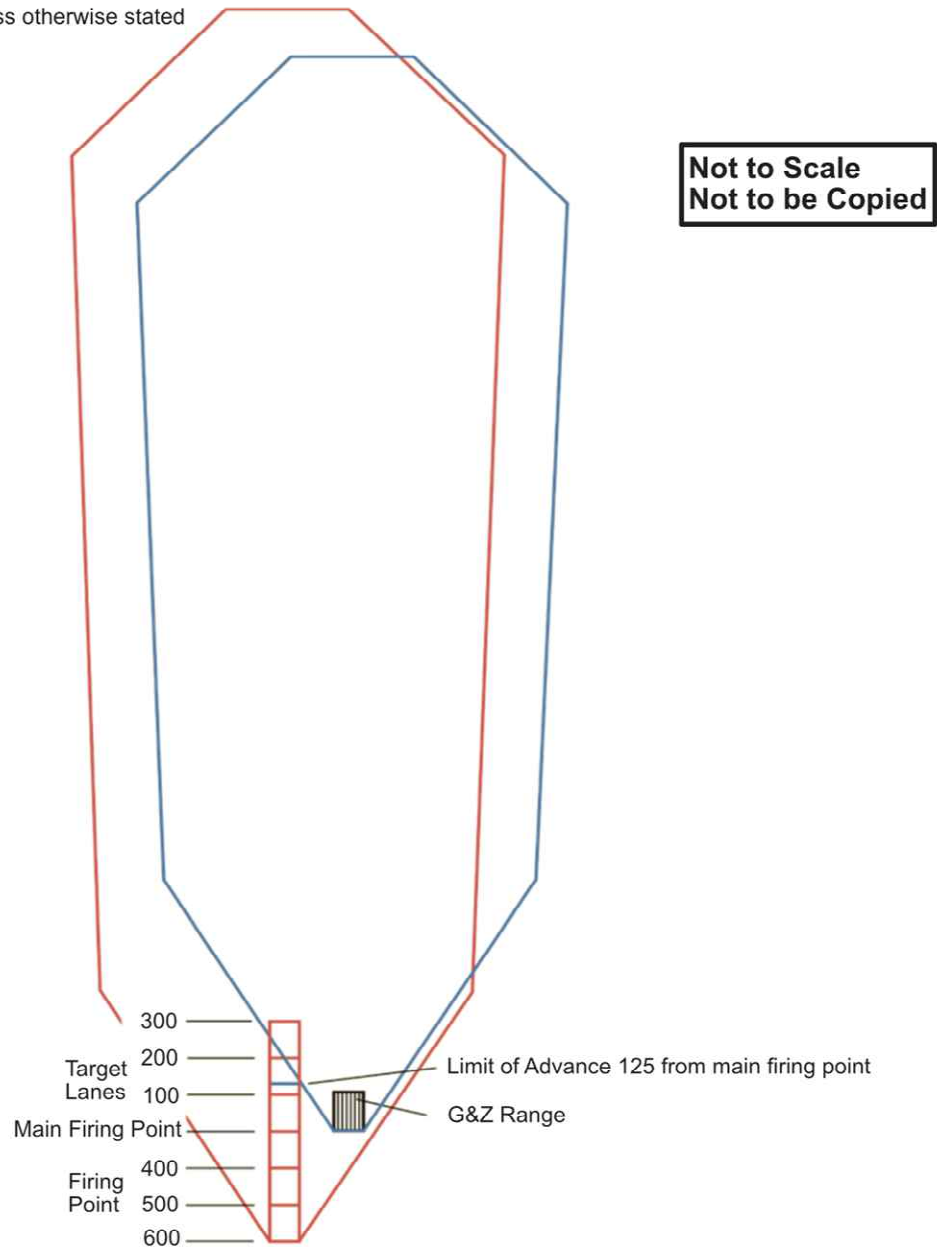

Notes:

1. ADH: 5.56mm and 9mm: 500ft, 7.62mm Ball 750ft, 7.62mm Tracer 1500ft.
(For ranges where the range floor is not shaped use LFTT ADH details in Chap 2, Table 2-1)
2. When firing 7.62mm Ball an Air Sentry may be required.

Fig 13 - 3. Siting of a G&Z Range on a ETR RDA Template. (RDA for 5.56mm and 7.62mm Ammunition shown)

All dimensions in millimetres unless otherwise stated

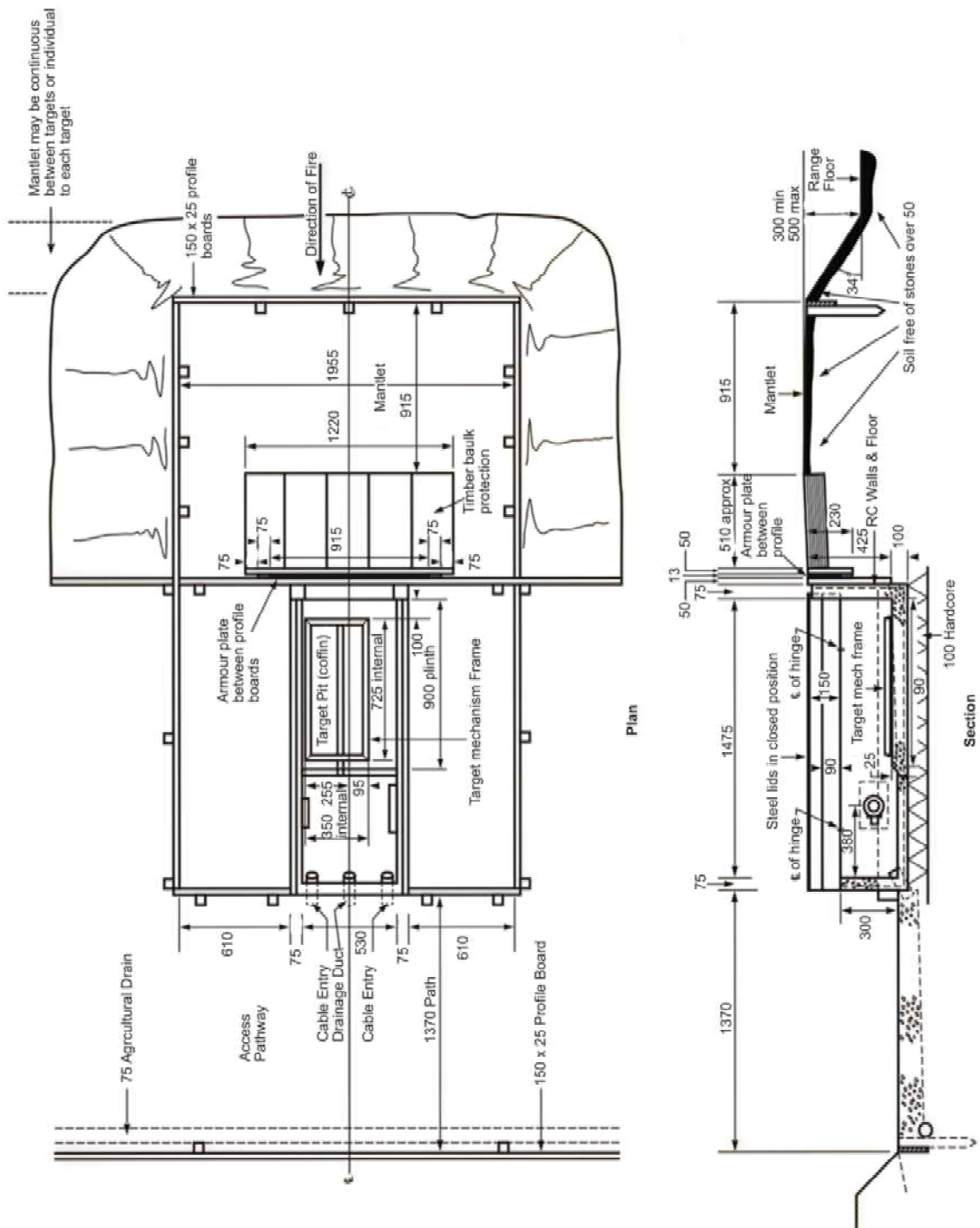

Fig 13 - 4. Typical Target Mechanism Location and Mantlet



Warminster



Sennelager

Fig 13 - 5. Typical Target Mechanisms Set Below Ground Level to Avoid Mantlet Attrition

Chapter 14 - The Individual Battle Shooting Range

The Individual Battle Shooting Range (IBSR) facilitates TLFTT Defensive Action Practices as described in Operational Shooting Policy. The photo below illustrates a typical existing IBSR. This chapter describes the design and construction of a standard IBSR.



14-01. **Description.** The IBSR is a purpose-built ETR extending to 350 - 400m for practising individuals or pairs of firers. The range is designed to practice a selection of fire positions, weapon handling skills, fieldcraft, and quick and accurate shooting at fleeting and moving targets at various distances. Two or more targets can be exposed simultaneously to train in instinctive engagement followed by rapid engagement of further targets. The range should provide defensive engagement of targets in depth from 50 - 400m from the firing point / start line and a patrol exercise in which targets appear during an advance to the 300m firing point, the limit of advance. The final 50m is a CQB shoot which concludes with a moving target. The range allows some LFTT exercises to be conducted:

- a. Single firer using various firing positions on the main firing point then moving down range selecting cover and engaging targets down range.
- b. A patrol exercise of two firers in each lane.
- c. A static defence exercise with four firers in each lane operating as a fire team.

Danger Areas

14-02. To establish the IBSR RDA, the WDA template is applied from each firing position to each target to build up an overall RDA trace. To ensure bullets do not leave the RDA, it is essential that shooting only takes place between the limit of advance posts onto designated targets. The production of an accurate RDA trace depends on fire and target positions being carefully surveyed. RITT must be requested to check or calculate all IBSR RDAs. The RDA must be re-calculated if target or fire positions are changed.

14-03. **Signs and Flags / Lights.** A range in use flag / light as described in Chapter 2 must be provided. Where appropriate signage and boundary demarcation may also be required as per Chapter 2.

Design

14-04. **Criteria.** The standard IBSR has four lanes each 25m wide and 350 - 400m long but local requirements may alter the number of lanes provided. A typical range layout is illustrated in Figs 14 - 1 and 14 - 2. Target spacing and layout remain the same in each lane, but cover may be varied to suit the terrain. The following weapons may be fired:

- a. **SA.** Rifle / GPMG firing 5.56, 7.62mm. Pistol, firing 9mm ammunition, by exception, however additional control measures will be required. See RITT for details.
- b. **IWS and Grenades.**
 - (1) 60mm light mortar firing Smk and Illum provided the ADH of 4000 ft is activated, and the WDA is contained within the overall RDA trace.
 - (2) Grenade Hand Smk Training and Grenade Hand Prac L111 may be thrown from behind cover on the main firing point into the grenade targets.

14-05. **Siting.** The range floor for a four lane IBSR requires an area 350m long by 100m wide. Sufficient space is required behind the start line for troops to assemble and for the range control building. The range is best sited on ground that is relatively level over the first 100m, rising over the remainder of its length and preferably to some distance beyond. The QE from any point of engagement must not exceed 150 mils (8.5^0) unless the FE template (4000m) can be applied. Bush and shrub growth should remain in a natural state with non-ricochet inducing obstacles providing cover for fire and movement skills. Care is required to ensure that the most distant targets are not silhouetted on the skyline. A well-drained site is essential as target mechanisms must be dug in. No deep, steep sided streams or ditches, or rocky outcrops are permitted. The natural terrain should be disturbed as little as possible consistent with the ability to ensure that:

- a. Target numbers 1 - 7 are visible from the main firing point and from the various minimum engagement distances.
- b. Target numbers 8 - 10 and the moving target are visible from the 300m limit of advance line.
- c. All targets are visible to the console operators in the control building.

Construction

Targetry

14-06. **Target Locations.** Ten FET are positioned in each lane at a minimum of 5m inside the lane boundaries. On existing ranges targets are typically fitted to FET as follows:

- a. Fig 12s usually for target numbers 1 - 4 and 8.
- b. Fig 11s usually for target numbers 5 - 7 and 9 - 10.
- c. Fig 11 or 12 may be presented as target number 7 that appears in a window. The target is to suit the window size and design.

14-07. **Fixed Electric Target Pit.** The FET equipment is protected with timber or rubber products, earth, and armour plate. Any hard surfaces are to be protected against

backsplash. The pit is large enough to accommodate the target in the down position and deep enough to locate the FET below the level of the range floor. The pit must be self-draining. FET may be set at ground level and the protection from all potential direct fire provided around it.

14-08. **Moving Targets.** Moving Target Systems (MTS) are used on these ranges on the 350 or 400m target line. The visible target run is approximately 20m long with an end of run screen that obscures the target from view at each end of the run. The target mechanisms are protected by a mantlet of grassed earth 1.5m thick with a vertical revetment at the rear.

Firing Lanes

14-09. **General.** Each lane on the standard IBSR contains the features set out in the paragraphs that follow.

14-10. **Targets.** 10 x FETs are connected to a console in the control building and Fig 20 targets are mounted on the MTS and forms the final targets.

14-11. **Limit of Advance Line.** The limit of advance line at 300m is clearly indicated by a wall incorporating building facades with gates, fencing, bushes etc, in a broken line across the full width of the range. This provides a variety of cover from which the firer may engage the final series of three FET and the moving targets in the CQB section.

14-12. **Main Firing Point.** The main firing point, from which the defensive engagement takes place, consists of ten different types of cover for each lane, as shown in Fig 14 - 2. The firing, point may be at ground level or raised on a bund up to 900mm high. It may be surfaced with 10mm single size rounded gravel chippings contained within timber profile boards.

14-13. **Minimum Engagement Distance Posts.** Minimum engagement distance posts are required to prevent the firer coming within the backsplash distance (refer Table 2 - Backsplash Zone) of the targets and to ensure all firing stays within the RDA. As positions of the posts will vary the relationship between posts and targets must be clearly articulated in Range Standing Orders.

14-14. **Boundary Posts.** Whilst it is highly desirable to interfere as little as possible with the natural terrain, it may be necessary for safety reasons to provide some indication to the firer of the limits of their lane to prevent engagement of the wrong target.

14-15. **Landscaping.** A series of landscape items of building facades, rural or farm structures, fences, gates etc must not impede the view of the targets or create a backsplash or ricochet hazard. Additional landscaping may enhance the IBSR by improving existing features. Range staff should exercise ingenuity in planting shrubs and encouraging the natural development of the range area.

Control Building

14-16. **General.** The control building is usually located approximately 10m centrally behind the line of the main firing points. The control room is on the first floor to ensure a good view over the range. Normally on the ground floor are the Range Warden's workshop and store with the troop shelter alongside. The concrete roof of the troop shelter also forms a viewing platform accessible from the control room.

14-17. **Fittings.** The following fittings are required in the control building:

- a. A console bench running the full width of the control room. The targetry control consoles are identical to those on an ETR, including provisions for an AMS.
- b. A full width window in the front, returned at each end of the control room to give an unobstructed view of the whole range. This window ideally should slope inwards from the top to eliminate glare and keep it clear of rain.
- c. Work benches in the Range Warden's workshop and, if target mechanisms are to be tested, a suitable electricity supply.
- d. Bench seats, and hat and coat hooks on the walls of the troop shelter.

Services

14-18. **Electricity.** Power requirements will vary from site to site. In addition to target operation, electricity is required for lighting, heating and power outlets in the control room and Range Warden's workshop. All external cables are to be buried underground to a suitable depth. Cable runs to the targetry are to be taken down one flank of the range with feeder spurs across the range on each target line. Connection pits, points, or service covers must not create a backsplash or ricochet hazard. All cables and fittings must be weatherproof and internal cables should be in steel conduit.

14-19. **Water and Drainage.** Water supply and drainage will be required.

Communications

14-20. The following communication systems are to be provided.

- a. **External.** A means of summoning the emergency services, ideally a land laid telephone is to be available.
- b. **Internal.** A PA system is installed with a microphone in the control room and on the main firing point for controlling practices and reading out scores.

Maintenance

14-21. **Responsibilities.** Maintenance is the responsibility of the RAU. Responsibilities may be divided as follows:

- a. **Range Warden.** See DSA 03.OME Part 3 Volume 1 Part 2.
- b. **Property Management.**
 - (1) Grounds.
 - (2) Fencing and sign posting (see Chapter 2).
 - (3) Structures, roads, and drainage including stability of slopes and erosion control.
 - (4) Water and electricity supplies.
 - (5) Periodic refurbishment of the range structure.

- c. **Equipment Management.** Repairing and servicing equipment installed by single service contract.

14-22. **Frequency.** Proper maintenance is dependent upon good liaison between the Range Warden and the RAU, and on properly scheduled maintenance periods. A heavily used range may need one day's maintenance each week plus one- or two-days' maintenance by the Range Warden each month. Two closed periods of a week or so may be needed each year for building and earthworks repair; this work should be combined with the contract repair of equipment.

14-23. **Shot Damage.** Shot damage to the constructed cover and target facades will require careful monitoring and repair if the IBSR is not to deteriorate. Grounds maintenance is of particular importance. Grass and shrubs help form the natural cover and will need cutting, pruning during the growing season and careful maintenance during wet or winter use. Care is to be taken to ensure that soil erosion does not expose backsplash hazards such as target mechanisms or rocky outcrops on the range floor, especially prevalent on banks immediately behind targets.

Compliance Checks

14-24. The following should be checked:

- a. Authorised weapons, ammunition, and practices.
- b. Lane identification and alignment from all firing positions.
- c. Target exposure.
- d. Protection to the moving mechanism and housing, if applicable.
- e. Quadrant Elevation.

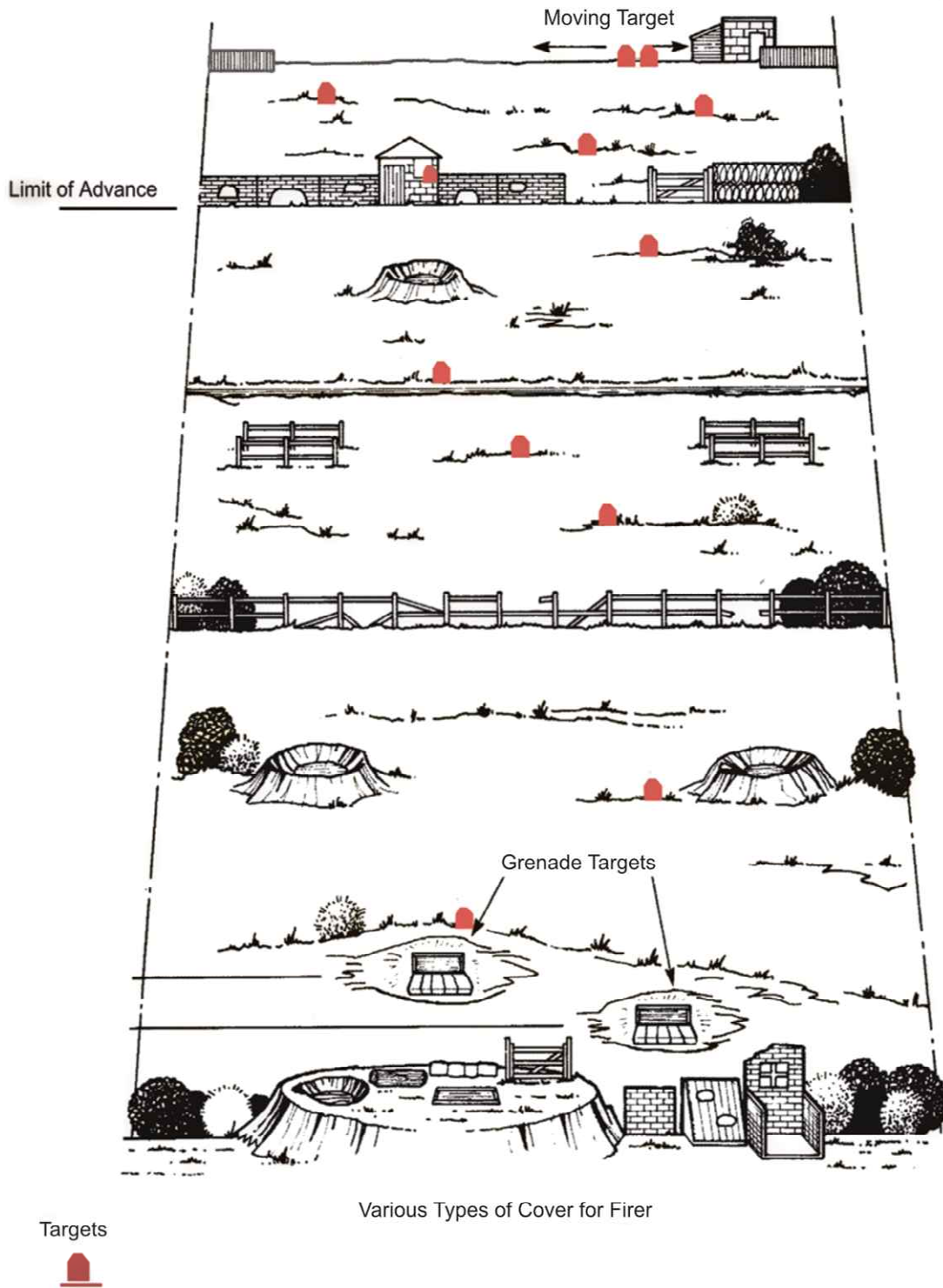

Fig 14 - 1. Typical Cover and Target Locations - Single Lane

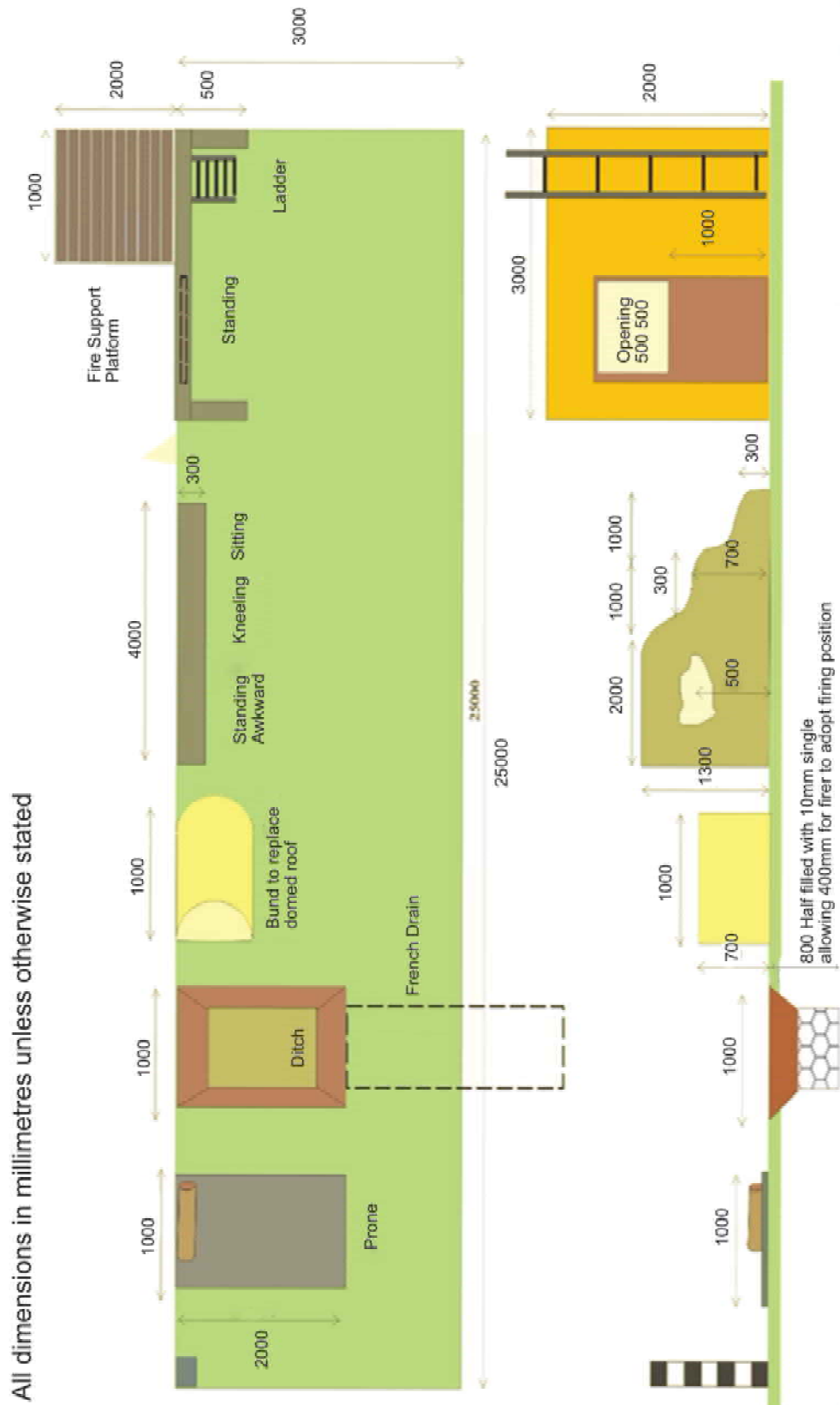

Fig 14 - 2. IBSR Firing Point

Chapter 15 - Live Firing Tactical Training Range and Close Quarter Battle (Rural) Range

Live Fire Tactical Training Areas (LFTTA) provide very realistic battle conditions having no artificial lanes and few structures to limit the arcs of fire. The scale of use is from individual to brigade level exercises. The concepts in this Chapter refer also to Close Quarter Battle (Rural), CQB(R) ranges. Live Firing Tactical Training (LFTT) is only to take place in accordance with Pamphlet 21. On some ranges, urban training facilities are provided. This chapter covers the facilities that may be required on an LFTTA.



15-01. **Purpose.** The LFTTA provides natural ground conditions for LFTT.

Danger Areas

15-02. **Range Danger Area.** Full advantage of the area can only be achieved by careful application of the appropriate WDA templates, and selection of movement boxes and target locations. Instructions for constructing RDA traces are given in Pamphlet 21.

15-03. **WDA Templates.** WDA templates for SA ammunition are illustrated in the Figs 15 - 2 and 15 - 3 to this Chapter. Where ricochet from ground strike may be expected use Fig 15 - 2. For HEF where no ground strike is expected use Fig 15 - 3. Other IWS may form part of an LFTT exercise and their WDAs need to be included within the RDA trace. These IWS WDAs are to be found in the appropriate Chapter of DSA 03.OME Part 3 Volume 2.

15-04. **Impact Areas.** Refer to Chapter 2.

Design

15-05. **Design Criteria.**

- a. **Size.** The size of the area, the ground conditions, and arcs of fire available will determine the size and scope of the LFTT exercise which can take place. The WDA templates illustrated in this Chapter and the relevant Chapters of DSA 03.OME Part 3 Volume 2 give the areas required for various circumstances. The exception will be where troops exercise overseas and the host nation WDA are greater than UK

standard WDA. In this case the host nation WDA are to be used on the perimeter of the allocated training area.

b. **Scope.** The LFTTA should provide scope for realistic LFTT in all phases of war using as wide a variety of SA and IWS ammunition natures as possible.

15-06. **Siting.** Any ground suitable to the purposes of the exercise may be used. Rocky ground should be avoided in the target areas as this will create backslash and ricochet dangers, and difficulty in excavating target pits. Where multiple CQB(R) trails are set out in difficult ground where there is no inter visibility, Planning Officers must ensure there is template separation for each engagement possibility.

15-07. **Application of WDA Template Soft Ricochet Angle.** The 530mils (30°) soft ricochet angle is generally applied to the CoF from the firing position on the assumption that the ground in front of the firer is clear of hard surfaces within his CoF for at least 50m (the backslash limit). If this assumption is incorrect then refer to Fig 15 - 2.

Construction

General

15-08. As little construction as possible should be carried out on a LFTTA. The aim must be to maintain both flexibility and natural ground conditions. However, it may be necessary to construct or erect:

- a. Protection for target mechanisms.
- b. Effects bunkers.
- c. Arc and movement box markers.
- d. Trenches and weapon pits.
- e. Overhead or effects SA positions.
- f. Urban training façades.

Targetry

15-09. **Targets.** A wide variety of improvised and issued targets may be employed on a LFTTA (see Chapter 24). The protection described below refers to temporary target positions only.

15-10. **Target Protection.** Static target mechanisms should be installed in dug out pits or positioned behind protective raised banks or bunds. Moving target mechanisms and associated rails must be similarly protected over the full length of the target run. Target mechanism protection against SA fire can be achieved by 500mm of well compacted stone-free soil, 500mm of sand filled sandbags or 200mm (100mm for 0.22" rimfire and 9mm ammunition) of softwood timber. If target mechanisms are to be left out in a permanent or semi-permanent position, bullet protection should conform to LFMT standards, refer to Table 7 typically using wooden clad MS plates. Consideration is to be given to proper drainage and some form of weather / security cover for the mechanism and provided where necessary.

Firing Area

15-11. **Effects Bunkers.** Effects bunkers protect battle effects simulation teams from the ammunition for which the range is authorised. A bunker accommodates a minimum of two people sitting. The construction details of a typical bunker are shown in Fig 15 - 1. The bunker must be out of the direct LoF and protected on three sides and overhead by an earth mound or dug into the face of rising ground. The minimum thickness of earth required is 1.5m at the sides and rear, and 500m overhead. The mound is grassed to prevent erosion. Each bunker has a removable flagpole of sufficient height to ensure that when a 1.2m x 0.9m red flag is flown, it can be seen from all points of the movement box. Alternatively, a pivot pole with a red disc or ball on the raised end (as for the MMTTR bunker in Chapter 16) is to be fitted across the front of the bunker. A battery-operated red light is required for night firing.

Firing Positions

15-12. **Fire Trenches.** The construction of pre-dug positions should generally be avoided. It may however be necessary to construct a permanent facility such as a defensive position and care needs to be taken to reduce any resultant hazard to the public. Revetting may be either timber or pre-formed concrete box sections with the top of timber as per LFMT trenches, refer to paragraph 2-81a. (7) (b). Drainage will be required in permanent trenches. For details of temporary firing positions see relevant chapters.

15-13. **Movement Boxes.** As with arc markers, the marking of a movement box is to be avoided and only established where the limitations of the training area make it unavoidable. Where a requirement exists, movement boxes must be clearly marked out on the ground to avoid confusion. Timber marker posts painted in distinctive colours may mark the boundaries, and changes in arcs of fire or bearings (See Pamphlet 21).

15-14. **Grenade Throwing.** Details of trenches and bunkers for tactical grenade throwing are given in Chapter 18.

15-15. **Effects Guns.** The rules to be applied for using effects guns are contained in Pamphlet 21. Overhead fire towers may be provided with predetermined arcs of fire that include cleared areas out at 500m to enable correct setting of sights as set out in Pamphlet 21.

Supporting Structures

15-16. Range structures constructed on a LFTTA fall into three categories:

- a. Permanent structures constructed by the RAU in accordance with the criteria in this document. Details for structures in support of urban training are covered in Chapter 18. Details for HE grenade throwing is provided in Chapter 18. All permanent structures are to be added to the estate asset register to ensure funding for maintenance is provided and annual works inspections on the structures are carried out.
- b. Temporary structures provided by the RAU, but erected by exercising troops, are normally shoot through training aids in support of current operations. Such structures are to be intrinsically safe to ensure close engagement is possible without risk of backsplash or unexpected ricochet.

- c. Permanent and temporary HE grenade throwing structures. The protection requirements are set out in this document for permanent structures and in Pamphlet 21 for temporary structures.

Communications

15-17. **External.** A means of summoning the emergency services, ideally a land laid telephone is to be available.

15-18. **Internal.** Radio is the preferred method of communication, adding realism to the exercise. A fail-safe back up system is however essential. A direct and reliable link to range control should be available where possible. Effects bunkers, overhead fire, effects weapons and battle simulation control may require an installed telephone link with buried and protected lines.

Maintenance

15-19. **Responsibilities.** Sufficient stores will be needed as a LFTTA will normally require a large quantity of target mechanisms, targetry, defence stores and grounds maintenance equipment. A workshop should also be available to service and repair targets and target mechanisms, and for battery charging. Stores and workshops should be conveniently sited and connected by a metalled road. Maintenance of a LFTTA is the responsibility of the RAU. Responsibilities may be divided as follows:

- a. **Range Warden.** See DSA 03.OME Part 3 Volume 1 Part 2.
- b. **Property Management:**
 - (1) Building and structure maintenance, including overhead fire towers, services, earthworks and, if applicable, Armoured Fighting Vehicle (AFV) route repairs.
 - (2) Moving targets or repairing the ground around targets to prevent firers recognising the area before targets appear.
 - (3) Grass, shrubs, and trees are essential to the natural cover and will need cutting, pruning and a planting or re-seeding programme.
 - (4) For fencing and signing.
- c. **Equipment Management.** Repairing and servicing equipment installed by Single Service Contract.

15-20. **Backsplash Hazards.** To reduce the hazard of backsplash, particular care is required to monitor shot damage to target pits to ensure that soil erosion does not expose rocky areas.

15-21. **Frequency.** Proper maintenance depends on good liaison between the Range Warden and the RAU, and on properly scheduled maintenance periods. A heavily used LFTTA may require two to four days' maintenance by the Range Warden each month. Two closed periods may be needed each year for planting and earthworks to preserve the natural environment.

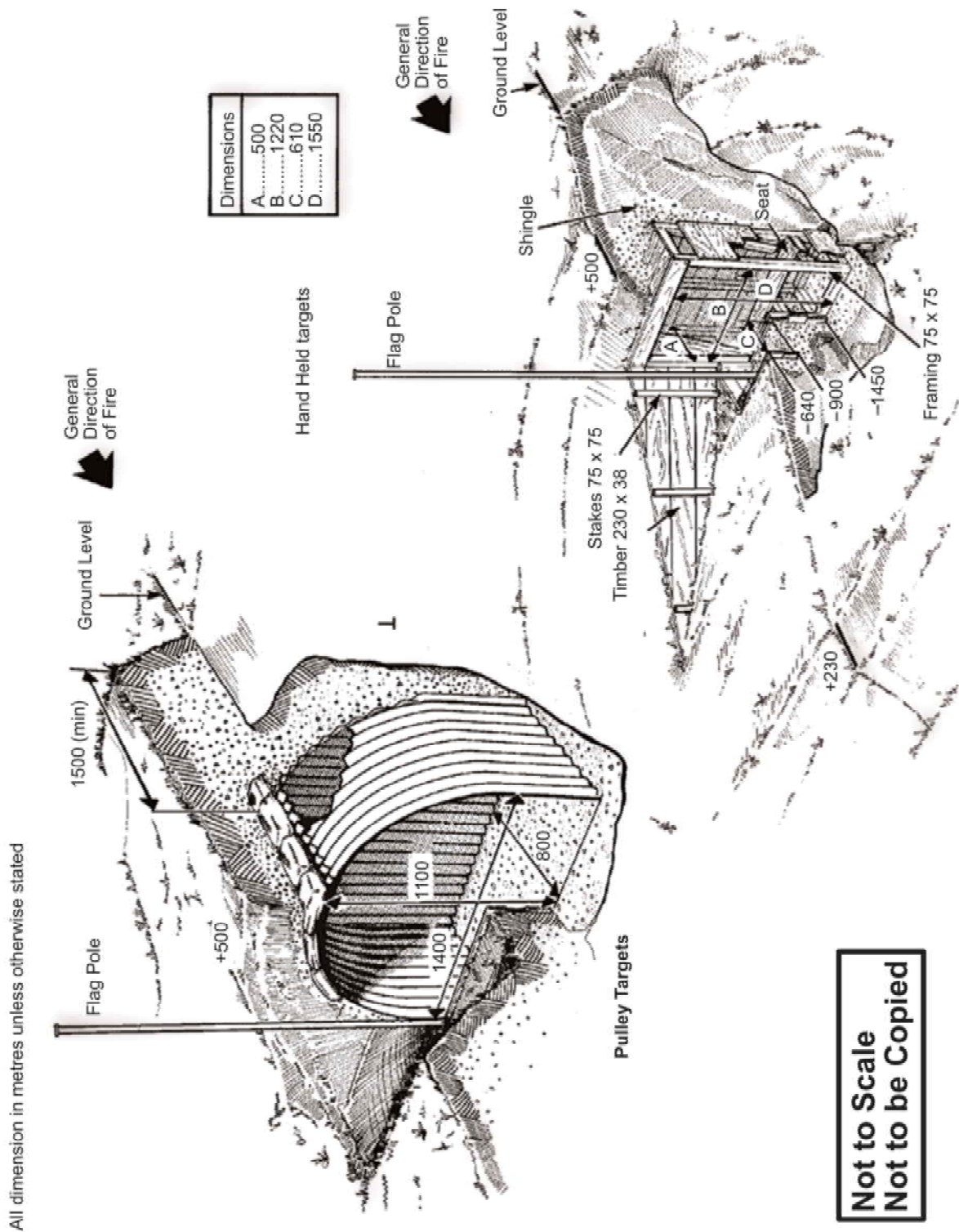
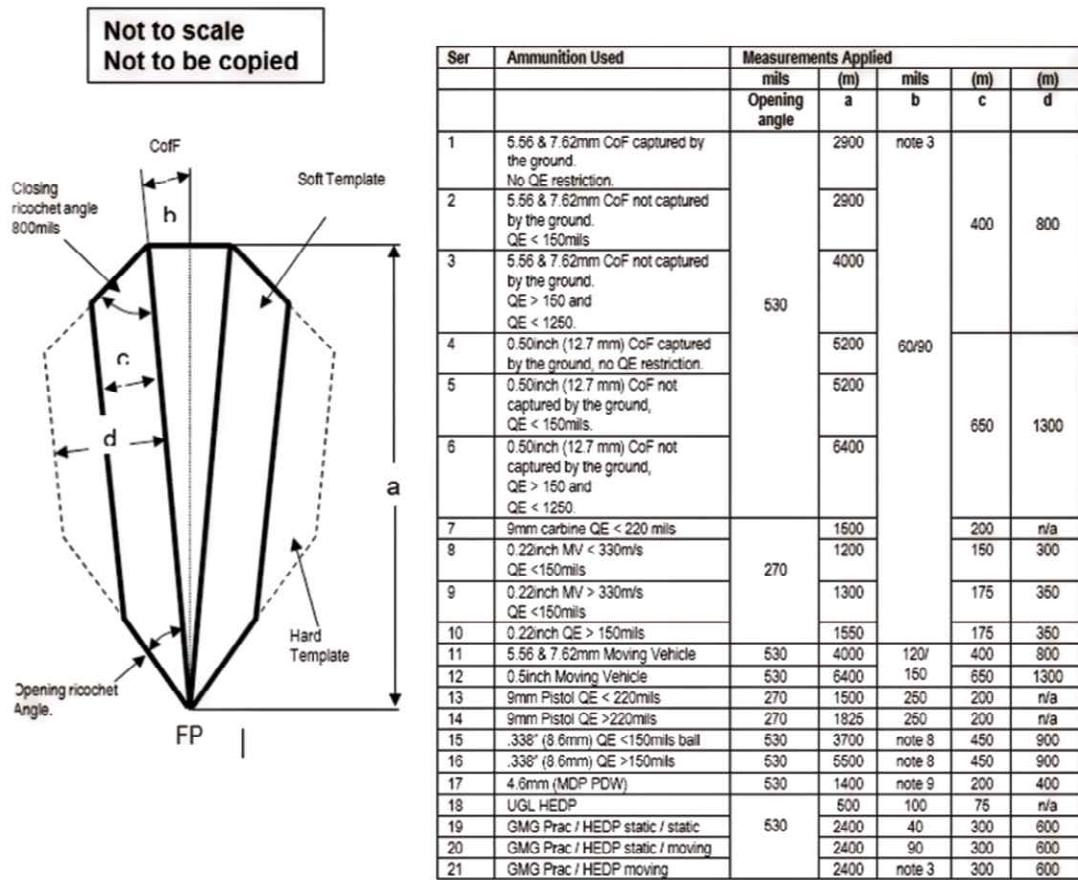

Fig 15 - 1. Effects Bunker



Notes:

1. The application of the WDA template is given in Pamphlet 21.
2. The ground template is only to be used when penetrable targets are engaged on ground free from any hard ricochet or backslash inducing material.
3. Column b:
Serials 1-10 static to static single shot and burst fire = 60mils; moving targets = 90mils.
Serials 11-12 & 21 moving vehicles on prepared flat ground = 120mils; on rough ground = 150mils. For other CoF angles see Chapter 2 Table 3.
4. All ADH information is provided in Chapter 2 Table 1.
5. This table refers to Ball, tracer or in serials >150mils, AP ammunition.
- 6.UGL HEDP Ser.18 has RBSD of 315m and NBSD of 450m. Minimum engagement distance is 150m.
- 7.GMG HEDP Ser.20 has RBSD of 220m and NBSD of 310m. Minimum engagement distance is 220m.
- 8.Refer to Table 3 Authorised SA Cones of Fire to be Applied on SA Ranges.
- 9.As carbine - 60mils. As pistol (butt folded) - 250 mils.

Fig 15 - 2. WDA Template SA Ammunition

Not to scale
Not to be copied

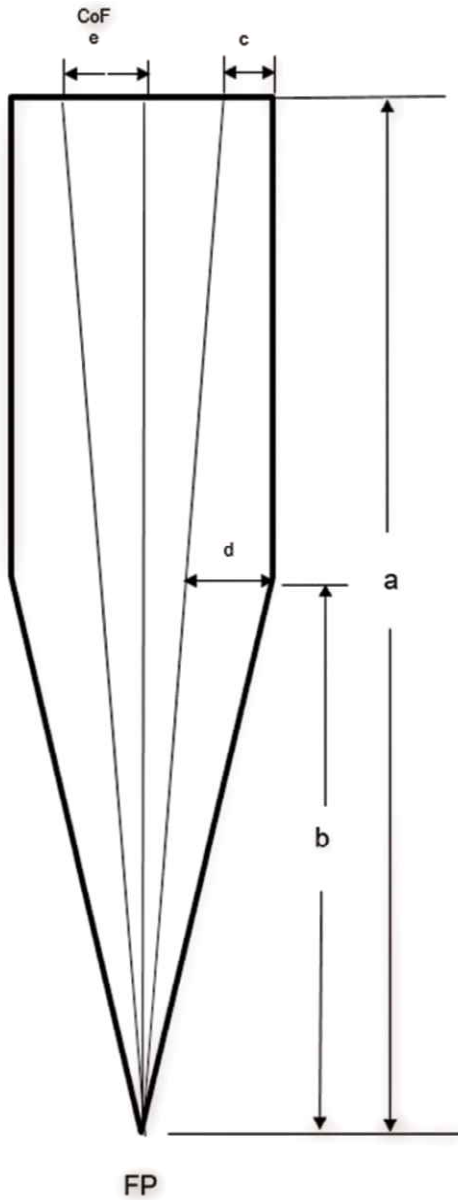

Se r	Ammunition	Measurements to be Applied				
		(m)	(m)	(m)	(m)	(mils)
		(a)	(b)	(c)	(d)	(e)
1	5.56 & 7.62mm	4000	2100	200	325	150
2	12.7mm (0.5")	6400	4000	250	350	150
3	.22", < 330m/s	1450	800	100	175	150
4	.22", > 330m/s	1550	800	100	175	150
5	9mm ball	1825	1000	150	200	40

Note:

1. Dimension 'd' represents an allowance for wind.
2. For ADH refer to Chapter 2 Table 1.
3. Ball, tracer, or AP.
4. 9mm (less moving vehicle) Vertex Ht.1225m
5. Details for 4.6mm ammunition awaited.

Fig 15 - 3. HEF WDA Template SA Ammunition 150mils<QE<1250mils

Not to scale
Not to be copied

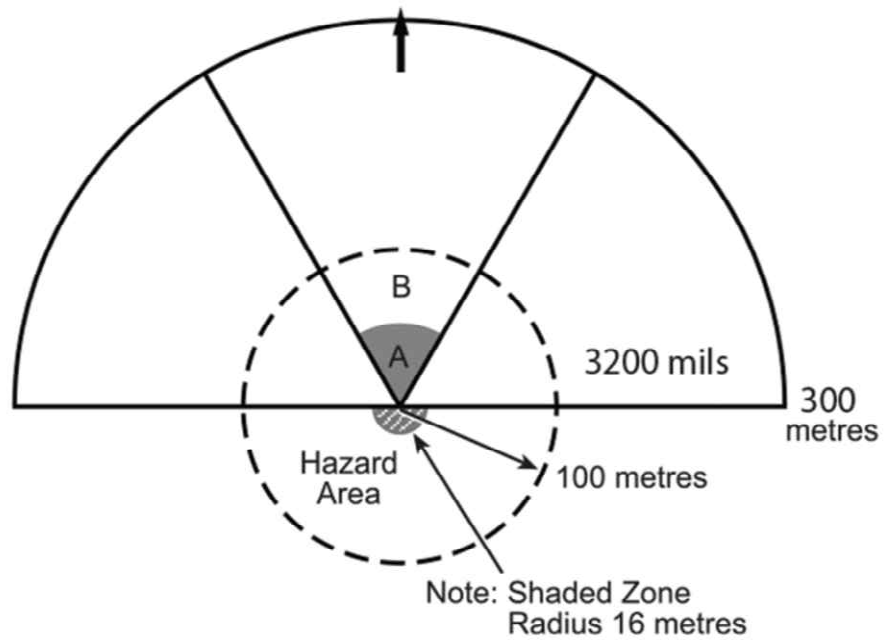

Notes:

1. All personnel are to be excluded from the 16m area once the device is armed.
2. No personnel are to be forward of a line perpendicular to the axis of the device.
3. All personnel closer than 100m to the back of the device are to wear PPE and be behind cover.

Fig 15 - 4. Weapon Danger Area (WDA) for M18A1 (Claymore)

Not to Scale
Not to be Copied

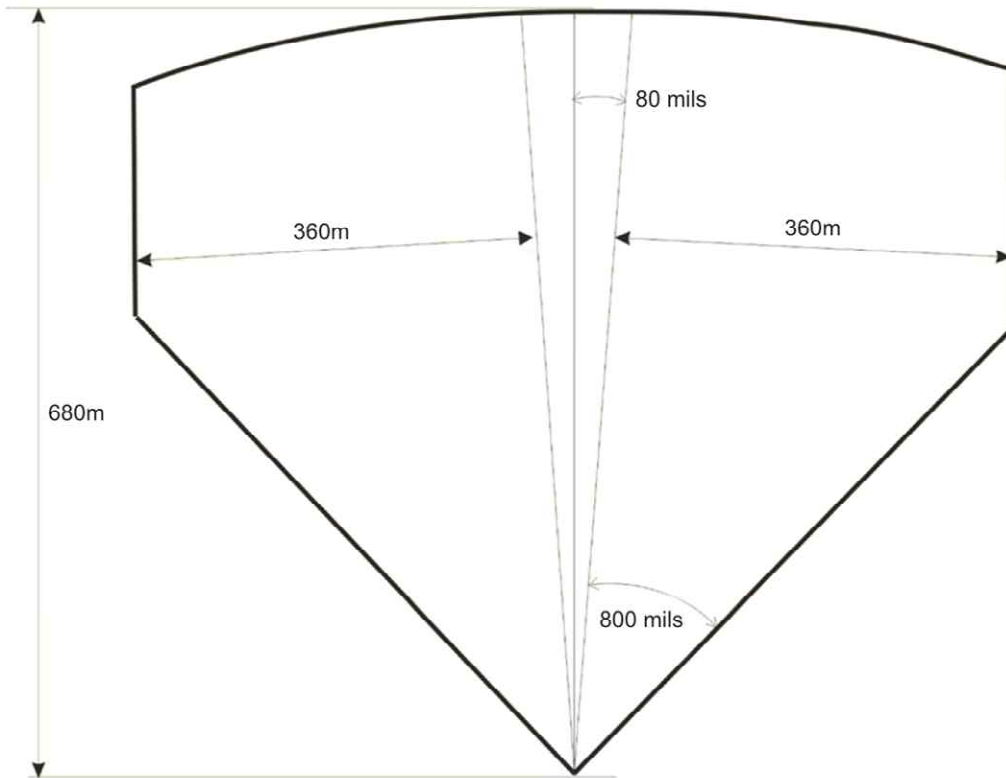

ADH is 500ft on constructed ranges.
ADH is 1500ft on LFTTA.

Fig 15 - 5. WDA Template for Combat Shotgun (Slug)

Not to Scale
Not to be Copied

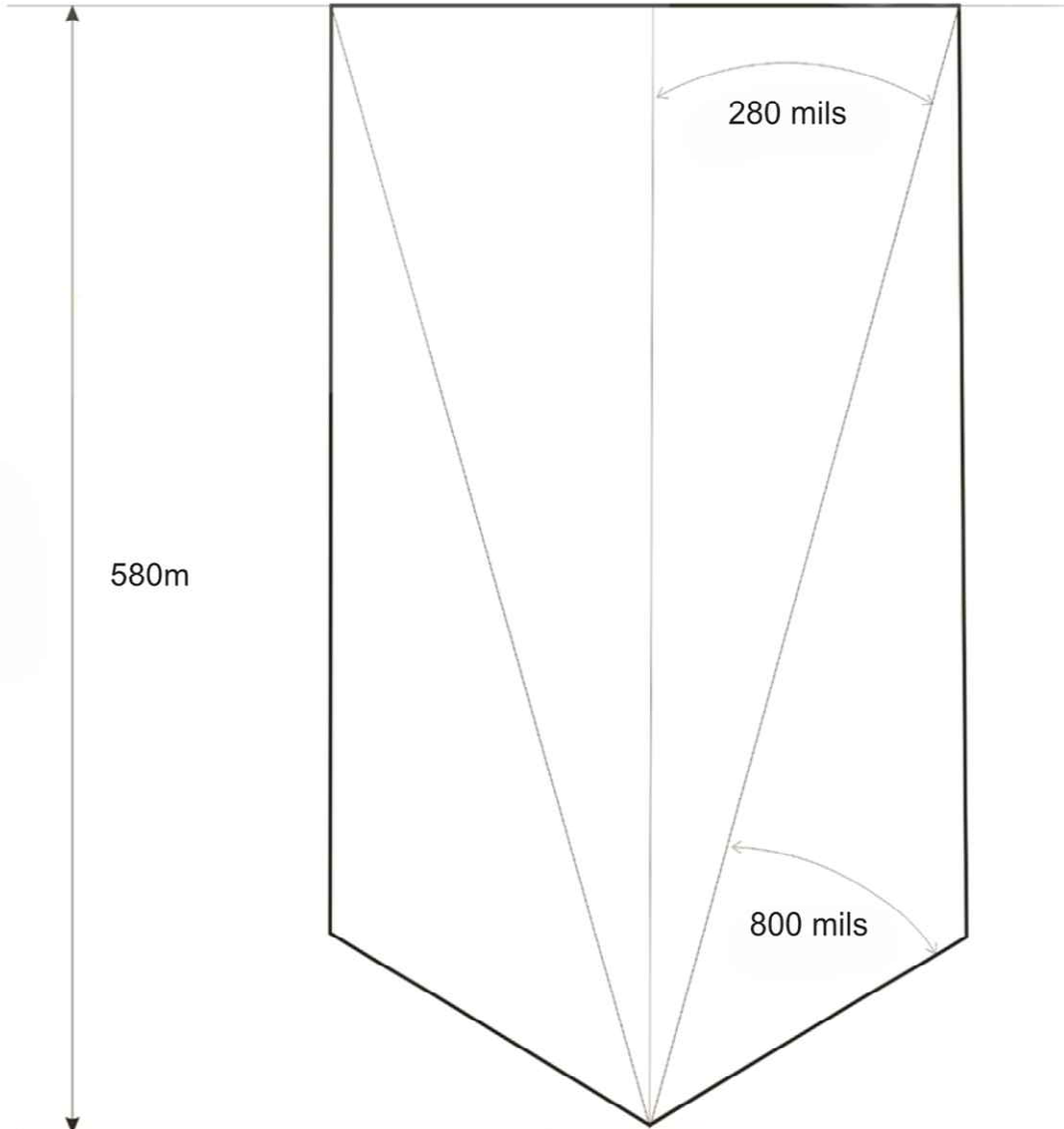

ADH is 500ft on constructed ranges QE<150
ADH is 1500ft on LFTTA

Fig 15 - 6. WDA Template for Combat Shotgun (Buck Shot)

Chapter 16 - The Mechanised Moving Target Trainer Range

The standard Mechanised Moving Target Trainer Range (MMTTR) is an open range with six lanes. Each lane has a moving target run of 10m. A markers' bunker at either end of each run limits the arcs of fire and enables the fall of shot to be indicated. If an AMS is installed on new ranges, the bunkers are not required but a control console will be necessary. Standard engagement distances are 50m and 100m and 150m, beyond which there is no current requirement. This chapter describes the design and construction requirements for a standard MMTTR.

16-01. **Purpose.** The MMTTR provides transition to LFTT training as set out in Operational Shooting Policy (OSP) in the engagement of moving targets at various speeds and ranges.

Range Danger Areas

16-02. **RDA.** The RDA for the MMTTR is shown in Fig 16 - 1. Where the original RDA was established from the centre of the 50m firing point the revised 100m firing point covering the width of a lane will not greatly affect the size of the RDA. Where existing RDA fall close to MOD boundaries RITT are to confirm the extent of the RDA.

16-03. **Template Overlap.** The minimum CoF to be used on MMTTR is 60mils (3.4⁰) see Fig 16 - 1. However, if this exceeds the DA available, it may be overcome by reducing the target run appropriately. This may be achieved by extending the timber boarding in front of the markers' bunkers.

16-04. **Hard Surfaces and Hard Targets.** Where hard surfaces exist or when hard targets are engaged, the hard target template wings are to be applied (see Fig 16 - 1).

Design

16-05. **Design Criteria.** This range is designed for firing 5.56mm and 7.62mm ammunition only at moving targets. If automatic (burst) SA practices are required to be used refer to RITT. The range is shown in outline in Fig 16 - 2.

16-06. **Siting.** The range requires level ground free of undulations and a gradient down-range that does not exceed 1:20. The gradient for the target railway is not to exceed 1:100. Wet marshy sites should be avoided, and the target run requires well drained stable ground.

16-07. **Dimensions.** The MMTTR and its RDA require a substantial area of ground. The total length of 3325m with an average width of 1132m is an area of 3,763,900m² (376 hectares or 930 acres).

16-08. **Night Firing.** The range can be used for night firing at a minimum engagement distance of 50m. A red range-in-use light is required.

Construction

Target Line

16-09. **Moving Target Equipment.** Typically, targets are mounted on four-wheel trolleys running on a narrow-gauge railway. The track is normally laid on concrete sleepers on a bed of ballast, which should be wide enough for an access path on each side. The six trolleys are moved at variable speeds by a winch cable which passes through a block anchored to an adjustable tensioning bar. The tension of the bar and anchorage is critical; if it is incorrect, the equipment fails to operate. The winch is in a hut which should be large enough to enable the winch to be serviced. The finished floor level of the winch room must be above that of the path to prevent flooding. Older MMTTR have the winch in a pit, which creates maintenance and condensation problems; the new hut design overcomes these. The hut is protected by an earth bund with a minimum thickness of 1.5m. Further details are shown in Fig 16 - 3.

16-10. **Turning Target Mechanisms.** Turning target mechanisms and sockets for zeroing screens may be included on the target line between bunkers. This extends the scope of range practices.

16-11. **Targets.** For elementary practices a screen with two targets mounted on it are used to teach application of lead by establishing where each shot strikes. The marker indicates the shot strike with a marking disc when the target is at rest behind the bunker. As experience and confidence are gained, the screen target is dispensed with, and the more advanced shot is presented with a single or a pair of single targets mounted on the trolley. Fig 20 targets can be used facing in the correct direction of movement. The targets used on this range are:

- a. Fig 20 Running Man.
- b. Locally made 'bandit' type using in-service veneers.
- c. Vehicle silhouettes no higher than a Fig 11 and the point of aim at the same height as a Fig 11 target.

16-12. **Sub Calibre Trainer Targets.** Only two targets on lanes 2 and 5 may be mounted as more targets put unacceptable stresses on the target moving equipment. Markers' bunkers are not to be manned.

16-13. **Mantlet.** A mantlet of stone-free soil protects the trolleys and rails from strike. It is to be of sufficient height above the track level to protect targetry from the highest firing position on the range. The face typically slopes to the range floor at an angle of 600mils (34°) and is to be 1.5m wide at the crest including the rear supporting wall, with a minimum earth depth of 1.0m. A crest board is set in to form the top edge of the mantlet forward face. The top of the mantlet should slope back from the crest at a fall of 1 in 12. Refer to Fig 16 - 4. The mantlet extends beyond the last markers' bunker to protect the cable tensioner at one end and is formed into an embankment to protect the winch hut at the other. The embankment face is also typically at an angle of 600mils (34°).

16-14. **Flagpoles and Lights.** A range in use flag is to be flown in the most prominent position for those approaching the range. A red light is fitted to the top of the pole for night firing. Where the flagpole is within the RDA it is to be of non-backsplash inducing material.

Markers Bunker

16-15. **Bunkers.** A typical markers' bunker is illustrated in Fig 16 - 4. The walls of the seven markers' bunkers are built in solid brick or concrete block. The roof is reinforced concrete and the floor concrete. To protect the occupants:

- a. A safety bar is fitted across the bunker opening for the marker to lower on entering; a red disc is fitted to the end of the bar so that in the raised position it signals stop firing.
- b. The inside of the bunker has a fitted bench seat, a shelf and a warning notice "DO NOT LEAN OUT WHEN TARGETS ARE MOVING" in 25mm white letters on a red background.
- c. If an AMS is fitted the bunkers will not be required. However, subject to local assessment, impenetrable 'end of run' screens are required noting that rounds can be deflected downwards after passing through penetrable timber and potentially damaging mover rails, target lifters and AMS equipment.

16-16. **Anti-Splash Screen.** Each bunker is shielded by a timber screen placed at least 600mm clear of its rear wall. The screen protects firers from backsplash and provides a gap for inspecting and repairing the brickwork of the wall. The screen is 3.6m long by 2m high and is constructed in 50mm minimum thick timber fixed to three 150mm square posts. A bar should be provided across the space between the bunker and screen to prevent it being used inadvertently for cover.

Firing Points

16-17. **Firing Points.** The whole of the target and mantlet must be visible from all firing positions. The firing points may be grass or 10mm single sized rounded gravel chippings retained by a light timber frame. There is no requirement for fire trenches. Structures representing fire from cover may be added to the 100m or 150m firing point as shown in Fig 16 - 5.

16-18. **Markings.** Firing points are marked out with 100mm x 50mm boards set on edge and flush with the range floor. A timber board, marked with the firing distance, on a timber stake is placed on each end of the firing points. Each lane has a numbered centre line indicator board as illustrated in Fig 16 - 2.

16-19. **Target Control Points.** A moving target control point may be sited on the flank and slightly behind each firing point (see Fig 16 - 2). Alternatively, it can be in a building behind the rearmost firing point.

Electricity Supply

16-20. Electricity is required to operate the winch and control unit. For isolated ranges this could be a generator located either in an extended winch hut or behind the rearmost firing point. The supply cable shall be buried 600mm deep, protected by cable tiles and run down the side of the range.

Communications

16-21. **External.** A means of summoning the emergency services, ideally a land laid telephone is to be available.

16-22. **Internal.** A telephone terminal connection is placed at each target control point to connect with a terminal in the centre markers' bunker for the RCO and NCO in charge of the markers to communicate. Commands between bunkers are by mouth. All cables are to be buried.

Maintenance

16-23. **Responsibilities.** Special attention is to be paid to the winch equipment, markers' bunkers and the mantlet. Maintenance is the responsibility of the RAU. Responsibilities may be divided as follows:

- a. **Range Warden.** See DSA 03.OME Part 3 Volume 1 Part 2.
- b. **Property Management.** General inspection with particular emphasis on:
 - (1) The stability of bunker back walls.
 - (2) The condition of timber clad walls.
 - (3) The moving target system.
- c. **Equipment Management.** Repairing and servicing equipment installed by single Service contract.

16-24. **Frequency.** Proper maintenance is dependent upon good liaison between the Range Warden and the RAU, and on properly scheduled maintenance periods. A heavily used range may need one day's maintenance each week plus one- or two-days' maintenance by the Range Warden each month. Two closed periods of a week or so may be needed each year for building and earthworks repair; this work should be combined with the contract repair of equipment.

16-25. **Marker's Bunkers.** As bunkers are damaged by shot, regular and careful inspection of the structure is essential to ensure that the walls do not become shot through. If the bullet penetration or scabbing depth is more than 10% of the thickness of the bunker wall the bunker must be taken out of use until repaired. Repairs must be completed with material that is at least as resistant to penetration as the existing structure.

16-26. **Mantlet.** The mantlet must be maintained to its full height and depth to ensure that trolleys and rails are not visible to firers from any firing point and that they cannot be struck by bullets.

Compliance Checks

16-27. The following are to be checked:

- a. Authorised weapons, ammunition, and practices.
- b. Main firing point profile.
- c. Lane identification and alignment from all firing points.
- d. Target exposure.
- e. Profile of mantlet and rail system.

- f. Protection to the moving mechanism and housing, if applicable.
- g. Construction and protection to markers bunkers.
- h. Quadrant Elevation.
- i. Template alignment.

All dimension in metres unless otherwise stated

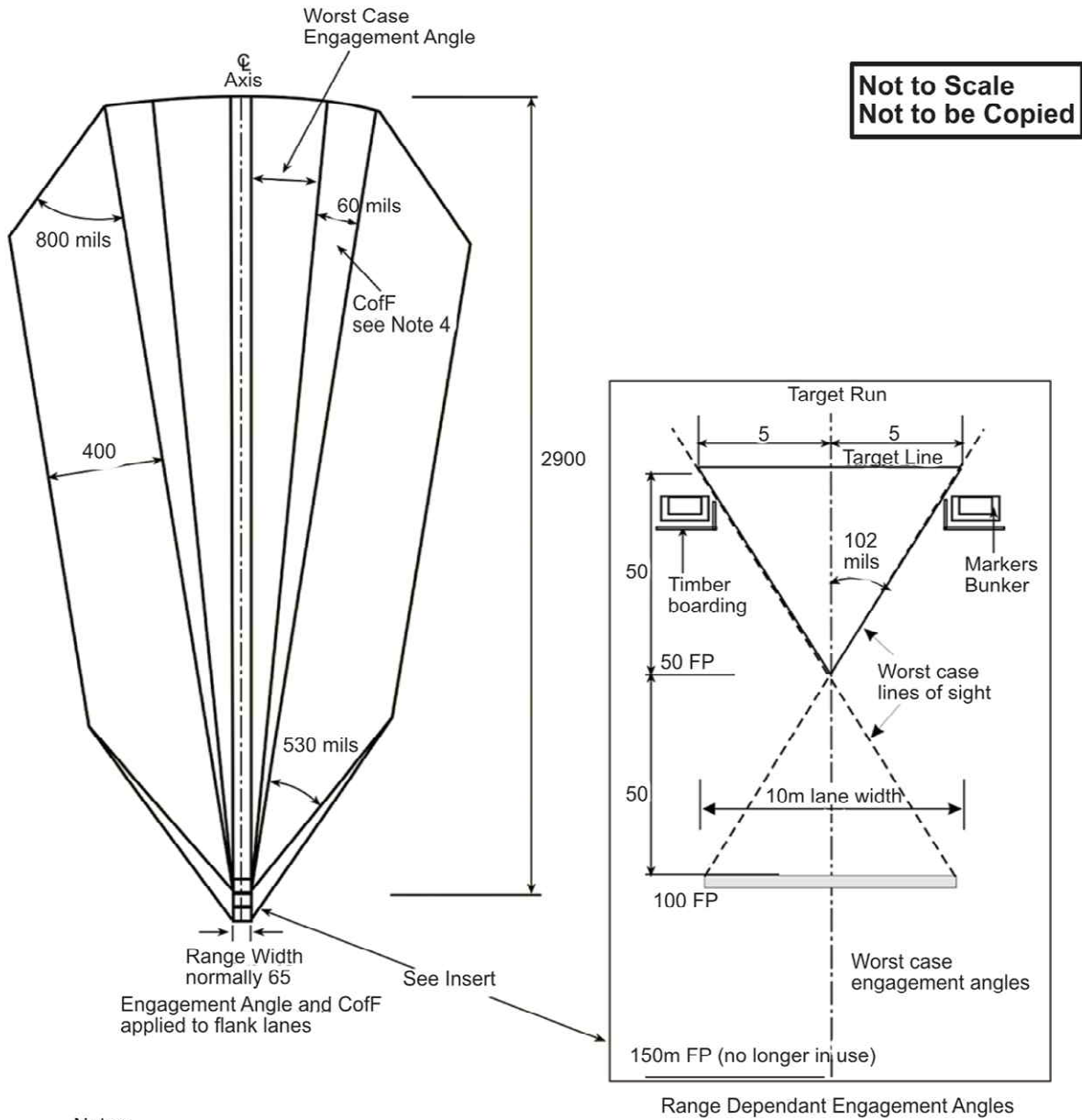

Notes:

1. ADH: 5.56mm Ball 500ft, 7.62mm Ball 750ft, 7.62mm Tracer 1500ft AGL.
2. When firing 7.62mm Ball an air sentry may be required.
3. Max permitted MV 1000 m/s, max permitted ME 7000j. See also Chap 2 Table 2-4.
4. Static - moving target: 60 mils single shot.
5. Where bunkers are not protected from all possible hard ricochet add 400m hard target wings.

Fig 16 - 1. RDA Template, MMTTR (RDA for 5.56mm and 7.62mm QE<150 mils Shown)

All dimension in metres unless otherwise stated

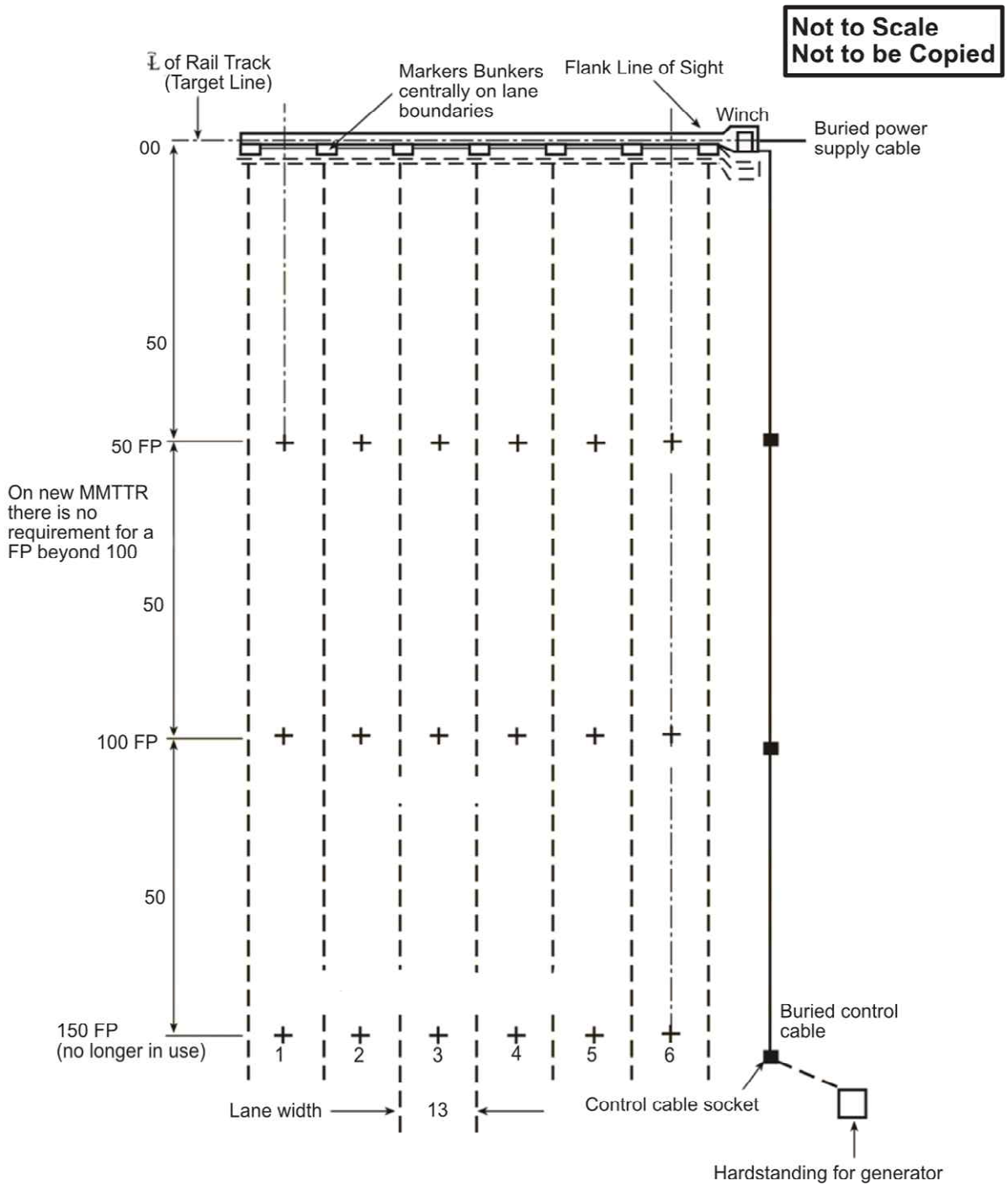

**Not to Scale
Not to be Copied**

Fig 16 - 2. MMTTR Layout

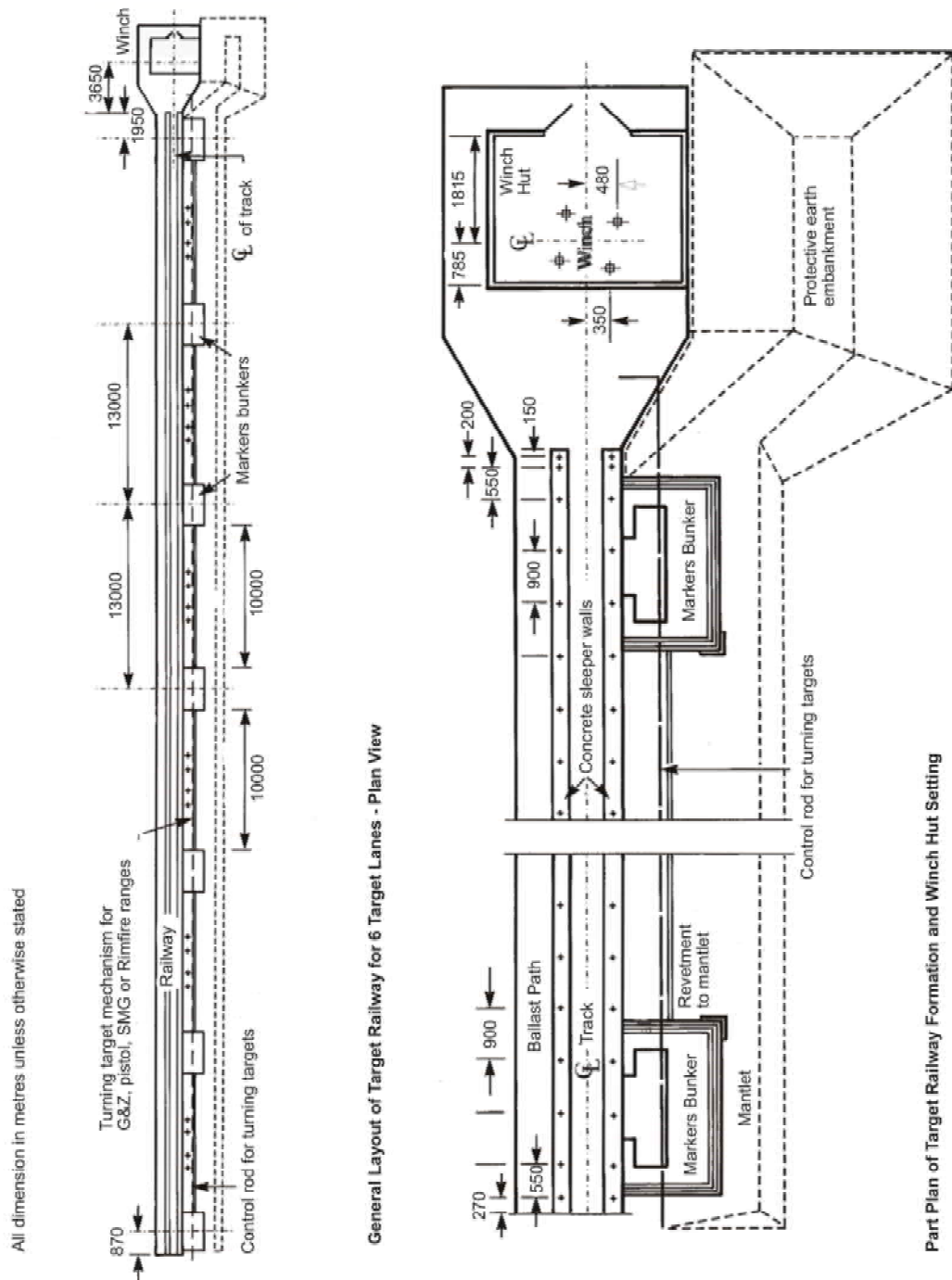

Fig 16 - 3. Railway and Winch Hut

All dimension in metres unless otherwise stated

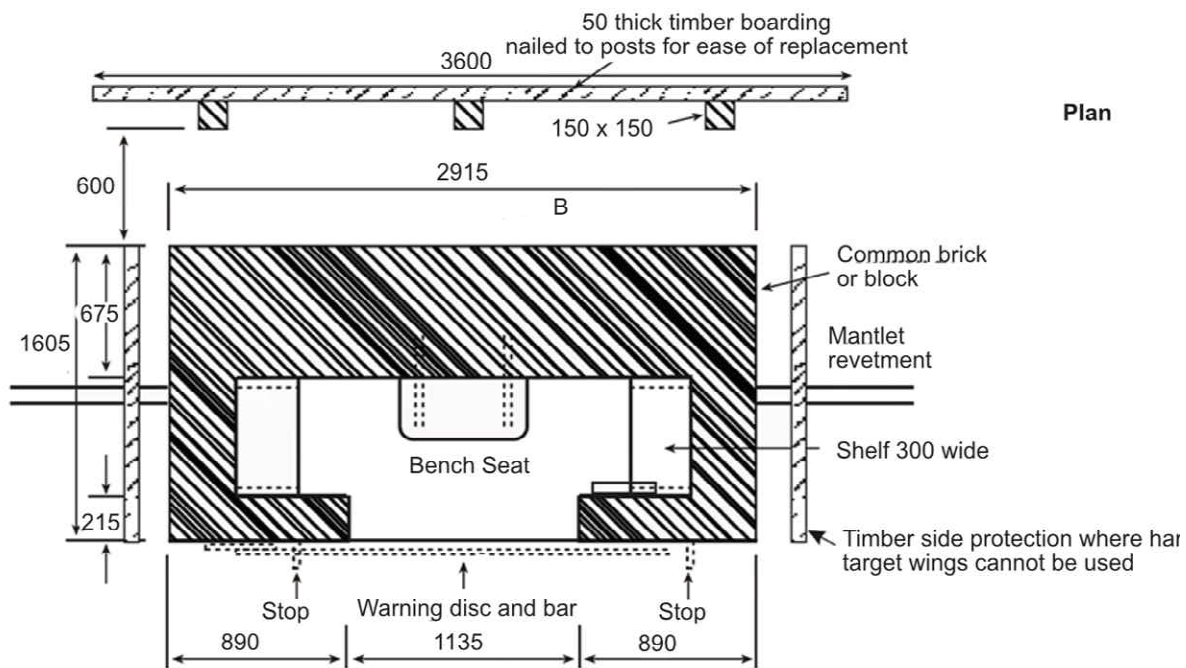
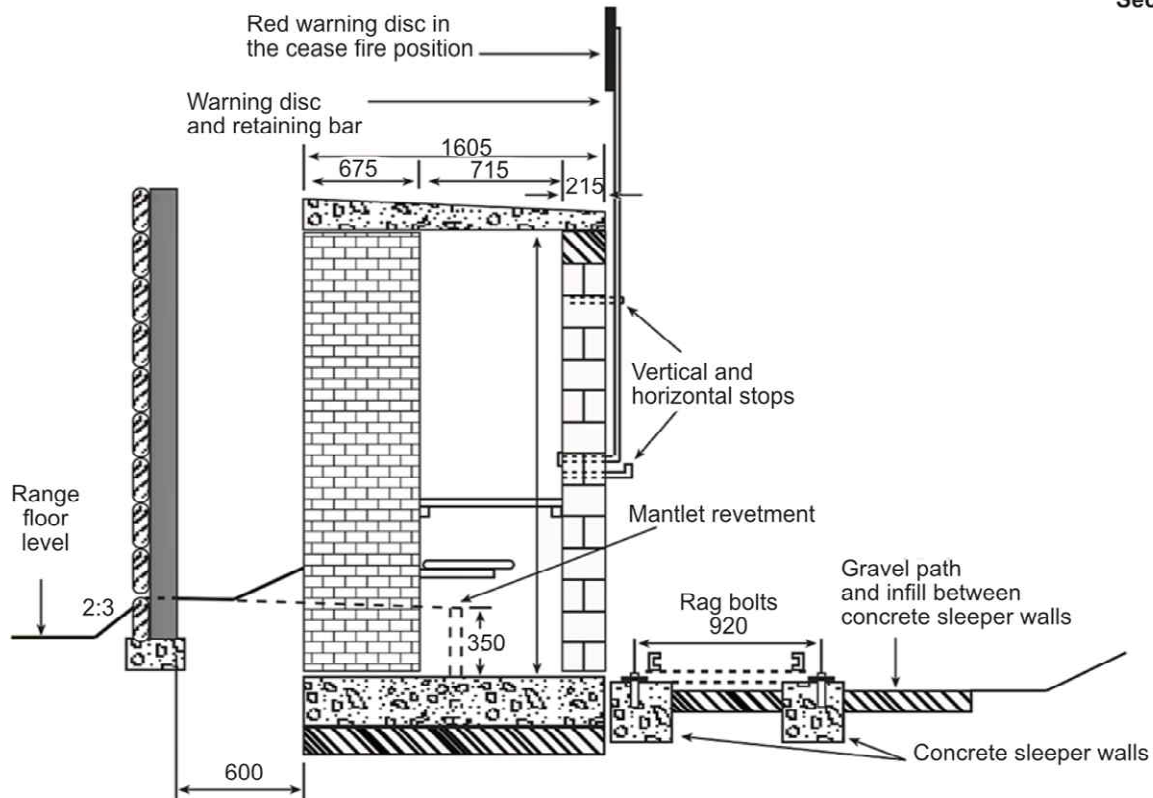

Fig 16 - 4. Markers' Bunker Detail

**Not to Scale
Not to be Copied**

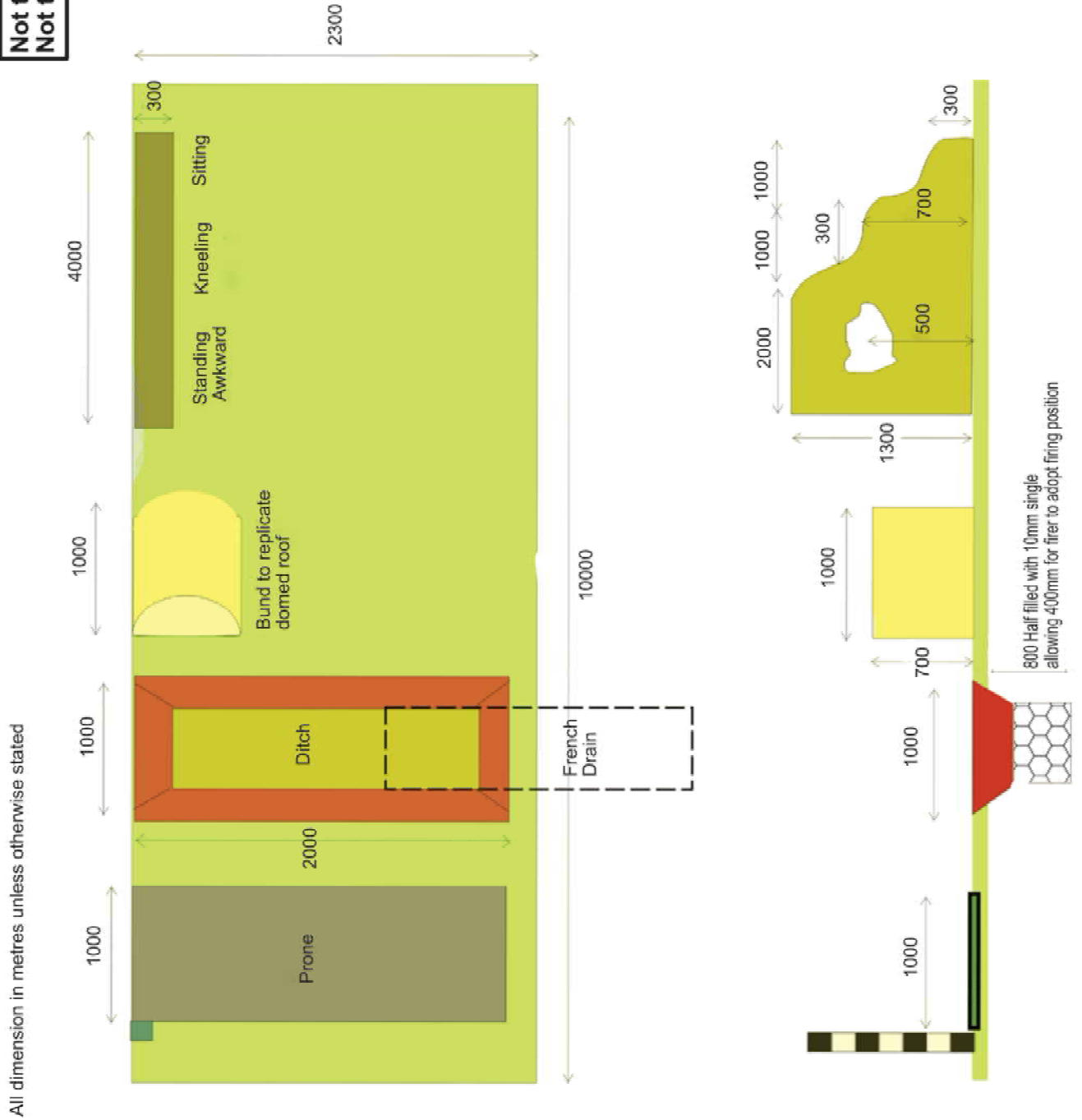

Fig 16 - 5. MMTTR Adapted Firing Point

Chapter 17 - MOD Test, Evaluation, Research and Proof (TERP) Ranges

This Chapter explains the governance of MOD owned TERP ranges some of which are operated by civilian contractors. TERP ranges cater for all environments (Land, Sea, Air and Space), all weapon and OME systems. The lead MOD agency (The Authority) is responsible for the implementation of range safety policy and standards in respect of these ranges. This Chapter deals with those TERP ranges that hold an MOD TERP Range Licence (MOD Form 905T). While appointments, titles and procedures may differ between different contractors, the principles are the same.



Fig 17 - 1. TERP Ranges Trial Activity

General

17-01. Due to their size and infrastructure, and adaptability TERP ranges can cater for all types of weapon systems and platforms; major users are from within defence and commercial sector.

17-02. The MOD has a responsibility to assure the safe operation of its contractor operated ranges. Whether TERP ranges are operated by MOD personnel or by a contractor, a robust safety management system must be in place. TERP ranges follow the mandate dictated by [DSA 01.1 Regulations](#) and [DSA 02.OME Regulations](#). Due to the diversity of TERP Ranges and the nature of the activities undertaken, the full requirements of DSA 02.OME may not always be applicable but must, as a minimum, comply with the MOD's Range Safety Management principles¹.

¹ DSA 03.OME Part 3 - Defence Code of Practice (DCOP) and Guidance Notes for Ranges.

17-03. **Defence OME Regulations.** TERP range operations shall follow the principles as defined in DSA Range Regulations Safe Place, Safe People, Safe Practice and Safe Equipment².

Governance

17-04. Governance is exercised by the Range Approving Officer (RAO) as nominated by the TLB. The Regulator (DOSR TL) will authorise TERP ranges with a MOD TERP Range Licence (MOD Form 905T). The MOD Form 905T forms part of the Acceptable Means of Compliance. The MOD Form 905T is to be re-issued by the Regulator at intervals not exceeding three years provided the range remains safe for use. The re-issue shall be made after the inspection of the range in that year, using the latest version of the form, provided the inspection report indicates that the range remains safe for use.

17-05. **Range Administrating Unit (RAU).** Where a range is operated by a Contractor the RAU shall assure the Contractor is suitable for the task of safely operating the range(s), by confirming that safety mechanisms are embedded, recognized, and maintained to ensure the safe operation.

17-06. **Head of Site (HoS).** Each TERP site will have a nominated individual as HoS³. As well as ensuring that any activity undertaken on a range is within the scope authorised by the MOD Form 905T and is approved by the Authority, the HoS is also responsible for ensuring staff are current and competent⁴ to undertake their relevant roles and responsibilities. Additionally, all personnel involved in range safety are to have current Certificates of Competence (CoC). Each site will have available on request of the RAU, in all cases and as a minimum, specific documentation covering:

- a. Top Level SHEF Regime.
- b. Safety Case.
- c. Range Standing Orders, Complex generic and range specific.
- d. Access to current and relevant documentation for weapon systems.
- e. Effective Over-Arching Integrated Risk Assessment Regime.
- f. The maintenance of an Effective Safety Management System (SMS).
- g. Safe Conduct of Trials.
- h. Effective Security Controls.
- i. Sustainable Development and Environmental Protection Regime.

² DSA 02 Defence OME Regulations – Part 1

³ For Dstl ranges, the nominated HoS may also be the Hd RAU.

⁴ Regardless of appointment, it is the individual's responsibility to remain current in all aspects of the role in which they are to be employed. Where doubt arises, advice is to be sought and appropriate refresher training undertaken. Firers/operators must have passed the appropriate WHT within the qualifying period contained in the appropriate service publication. To be deemed competent, an individual must be qualified or authorized, experienced and current and have the correct attitude to participate as range staff.

17-07. **Range Safety.** TERP Range operators shall ensure a safe methodology is established to ensure the safe planning and conduct of trials. A clear safety structure is to be maintained for approving and maintaining Safe Systems of Work (SSoW) for all TERP activities and the availability of in-service publications for weapon systems. Competency of the Range Safety Officer (RSO), Trial Conducting Officer (TCO)⁵ and other key trials staff⁶ shall be available for annual review.

17-08. **Regulatory and Responsibility for Range Safety (DE&S TERP Ranges).** Tables 1 and 2 identifies the safety chain of command together with the corresponding responsibilities for the MOD and Contractors respectively.

Table 17-1 – MOD Responsibilities

Role	Responsibility	Outputs
DOSR	Higher policy direction & political clearance of range safety matters.	DSA03.OME Regulatory Documentation Co-signatory on MOD Form 905T
RAO	Direction and policy on safety matters. Authority to bring ranges into use / stop their use when required. Monitoring safe operation. Implementation of MoD policy.	Co signatory on MOD Form 905T
Head of RAU	Appointment of Establishment Managers ⁷ Assure the safe operation of ranges. Advise the RAO	Attend DRSC Plan and deliver TERP 1 and 2 LODA Programme
DOSR	Independent range inspections/inspection programmes. Provision of advice on specific range safety problems.	RSIT Triennial Report
MOD Establishment Managers	To provide assurance to the RAO/RAU that the contractor operating the ranges specified within the contract is compliant with contractual requirements and regulatory obligations regarding Safety, Environment, Security and Estates Conduct LoDA	Annual Inspection Reports on MOD Form 907T(A)

⁵ TCO also applies to Trial Managers and other equivalent appointments of those responsible for conducting trials.

⁶ This includes In Flight Safety Officer (IFSO) and Ground Safety Offer (GSO) for Air ranges; Laser Safety Officer (LSO) where applicable and Firing Officer.

⁷ This appointment is used on LTPA sites. Other agencies will have similar appointments under different titles.

Table 17-2 – Contractor Responsibilities

Role	Responsibility	Authorisation/Outputs
Head of Site (HoS)	Ensure the delivery of Safe System of Work (SSOW) through the issue of Range Standing Orders and other safety documentation.	Appointment as HoS approved by Director of Operations, Maritime and Land
Head of Trials Safety ⁸	Annual Certification of all individuals appointed as RSO	Appointment as Head of Trials Safety approved by Director Maritime and Land Operations
Head of Trials Management ⁹	Annual Certification of all individuals appointed as TCO.	Appointment as Head of Trials Safety approved by Director Maritime and Land Operations
Range Safety Officer (RSO)	Ensures range maintenance of the safe place and compliance with risk assessments and task instructions for proof and trial activities. Monitoring of firings and trials to ensure safety	Individual Certificates of Competence issued by Head of Trials Safety
Trials Manager/ Conducting Officer (TM)/ (TCO)	The safe planning and conduct of the trials activity.	Individual Certificates of Competence issued by Head of Trials Management

17-09. **Assurance.** Table 17-3 outlines the MOD mandatory inspections, which provides assurance that statutory compliance, SSOW, Range documentation and site preservation are being maintained.

Table 17-3 - Cycle of Mandatory Periodic Inspections

MOD Record	Period	Assessor	Action
MOD Form 907T(M)	Monthly	RSO or competent and appointed person 1 LoDA	HoS
MOD Form 907T(A)	Annual	RAU Assurance 2 LoDA	The Authority
Estate Records	Biennial	Contractor Estate Management	HoS
MOD Form 907A: Independent	Triennial	DOSR 3 LoDA	RSIT
MOD Form 907A: Section 4	Triennial	DOSR 3 LoDA	RAU
MOD Form 907A: Section 5	Triennial	DOSR 3 LoDA	DRSC

⁸ For Dstl this is the Hd RAU, for contractor operated ranges this is the Range Safety Manager.

⁹ Dstl convene an annual licence panel.

17-10. **MOD Records.** In addition to the periodic inspection records, each site will maintain and produce:

- a. MOD Form 1057 suite of documents.
- b. MOD Form 906B. Test and Evaluation Range Log, to be retained by RAU for 10 years, from date of completion.

Danger Areas

17-11. **Range Danger Area.** Full advantage of the area can only be achieved by careful application of the appropriate and authorised Danger Area templates, and selection of specific trials activity locations.

17-12. **WDA Templates.** Danger Area templates for TERP activity must be provided or assured by the appropriate MOD authority and used to produce the trials safety trace. The appropriate MOD authority may be WESCOE, Pamphlet No 21, Pamphlet No 51 as well as the appropriate Chapter of DSA 03.OME Part 3 Volume 2.

Design

17-13. **Design Criteria.**

- a. **Size.** The size of the area, the ground conditions and, where applicable, arcs of fire available will determine the size and scope of the trials activity which can take place. The WDA templates in the relevant Chapters of DSA 03.OME Part 3 Volume 2 give the areas required for various circumstances.
- b. **Scope.** The TERP range should provide scope for a wide a variety of OME.

17-14. **Siting.** Any ground suitable to the purposes of the TERP activity may be used.

Air Danger Areas (ADA)¹⁰

- a. **Airspace.** Airspace is considered neither military nor civilian but seen as a national asset to be used flexibly on a day-to-day basis. UK airspace policy is contained in CAP740, and the MOD is an intrinsic part of the process. It is the CAA that provides authority for volumes of airspace to be designated for certain activities, such as segregation into danger areas for military purposes. Occasionally, temporary or extensions to air space are required and therefore any MOD airspace changes will involve DAATM¹¹ who represent the MOD, working alongside the CAA; this involvement is contained in MAA Regulations¹². To clarify: LTPA TERP ranges' ADAs are sponsored by DE&S at 1* level acting as Danger Area Authority (DAA) and managed by an appointed Danger Area Airspace Manager (DAAM), the DAAM will engage support from DAATM as required.
- b. **Notices to Aviation (NOTAM)¹³** ADAs are activated daily by NOTAM the Military Airspace Management Cell (MAMC) and ATC centres. Some ADAs have limited or unlimited height levels. In all cases, TERP ranges submit NOTAMs for the

¹⁰ CAA Safety and Airspace Regulation Group, Policy Statement, Danger Areas dated 17 Apr 2018.

¹¹ Defence Airspace and Air Traffic Management.

¹² MAA Regulations, (RA3201) and CAP1616.

¹³ The definition of NOTAM was changed on 1 Jul 21 by the Directorate of Flying Training (DfT).

maximum height/vertex required for the activity; this allows the CAA to utilise the remaining airspace if required.

- c. **Calculation of NOTAM.** A NOTAM, specific to the trial, shall be produced by obtaining the altitude of the weapon delivery system and subsequently adding the maximum vertex height for all trajectories in use. This is then converted to feet and a 3000ft buffer added to produce a NOTAM¹⁴.
- d. **Records.** Each range control shall maintain records (Logbook) of ADA utilisation in terms of date, timings (open / closed), hours used, activity and any air incursions. These are to be retained by RAU for 10 years.

Communications

17-15. When operational, ranges must have 2 independent means of communicating for safety and emergency situations and detailed Communication Plans listed in the Range Standing Orders. The normal configuration of communications used for TERP activities are:

- a. **External.** A means of summoning the emergency services, ideally a land laid telephone is to be available.
- b. **Internal.** Telephone is the preferred method of communication, A fail-safe back up system is however essential. A direct and reliable link to range control should be available where possible. Observation areas, firing areas and sentry locations may also require an installed telephone link with buried and protected lines.

Radio Frequency (RF) Operating Licences & RFDEW Trials

17-16. Under the terms of the Wireless Telegraphy Act, it is an offence to install or use a Radio Frequency (RF) transmitter or receiver except in accordance with a licence issued by the Secretary of State. The use of any apparatus without a valid Office of Communications (OFCOM) licence, Civil Aviation Authority (CAA) certificate/licence, Joint Spectrum Authority (JSA) or Authority to Radiate (ATR) can, by law, lead to heavy penalties, together with confiscation of equipment. Apparatus for which no proof of licence or authorisation can be produced is to be treated as being unlicensed.

17-17. When conducting RF DEW activities, each trials Safety Case must include evidence that the HERO, HERF and HERP effects of the main beam and any sub-beams have been considered and are ALARP. To minimise the risk to non-trials personnel, the HERP safe distance must be contained within the Range Danger Area; if this cannot be achieved the RAU is to be consulted.

17-18. All radio transmitters using open antennas must be properly licenced or authorised to radiate. Derogations may be applied once assessed as part of the safety case and where transmissions are contained within correctly operated, properly certified screened enclosures. In addition, all radio transmitters, regardless of configuration, must be operated under safe and positive control.

17-19. Licences, letters of authorisation and clearances are site specific. Separate frequency and site clearances must be obtained for any additional locations; this is

¹⁴ Royal Artillery Manual Volume VI Training Pamphlet No. 51 Regulations for Planning, Control, Conduct and Safety for Firing Practices.

particularly relevant if the equipment is mobile and deployed on trials away from its parent establishment. Projects responsible for the conduct of trials with new radar or radio equipment in NATO countries must request supportability from the country concerned at least six months prior to deployment. NATO supportability requests are submitted to the NATO Frequency Management Sub-Committee (FMSC) via the MOD JSA at Blandford.

17-20. **Trials.**

- a. RF operating licences in the MOD operating bands for TERP emitters can be obtained from the JSA whether it be a short-term period (duration of the trial), or fixed asset (e.g. Radar) which will be issued with a 5-year licence. Frequency licensing must be obtained from Ofcom, for any frequencies that are required for the Trial, including those necessary for command of the weapon, telemetry, and flight termination.
- b. For any additional jamming to take place, authority to radiate must be obtained from the JSA. All details of jamming frequencies and methods must be provided to the Range.

Meteorological (MET) Services

17-21. MET information is used to capture ballistic data for trials and to provide warnings to allow sufficient mitigation to be implemented.

- a. Data
 - (1) Surface and upper air data: wind speed, direction, air temperature, air pressure and humidity.
 - (2) Ballistic MET data to vertex and higher.
 - (3) MET throughout the trajectory.
- b. Warnings
 - (1) Acoustic trace - Predicted noise levels.
 - (2) Thunderstorms - Lightning risks.
 - (3) Sea conditions including total sea significant wave height, sea state, wind wave, wave period and direction for the specified trials area.

Authority and SME Tasking Process (DE&S TERP Activities)

17-22. The process identified below shall be followed when raising tasks with MOD depts, that are external to the LTPA contract delivery space (WESCOE, RITT etc):

17-23. All formal tasking in support of contracted activities is to be notified to and processed by the resident EM (RAU Rep), utilising the established and recognised tasking forms/process.

17-24. Once a task has been accepted and work has commenced on the delivery, liaison between the contractor SME and MOD dept will be authorised, noting that the RAU rep must be copied to ALL relevant correspondence.

17-25. Informal correspondence between the contractor and WESCOE, prior to a formal tasking should be expected (potentially to identify if a formal task is required), but this does not negate the requirement for the approved staffing route of formal taskings, as per sub para-a.

Trial Process

17-26. **The Basic Process.** From the simplest to the most complex trial or multi-national exercise, the trial process¹⁵ should follow the principles illustrated at Fig 17-2; this process ensures the following: HS&E aspects, technical ability, authorisation, briefings, and the final delivery (Report). Clear application of the process is contained in sites' procedures.

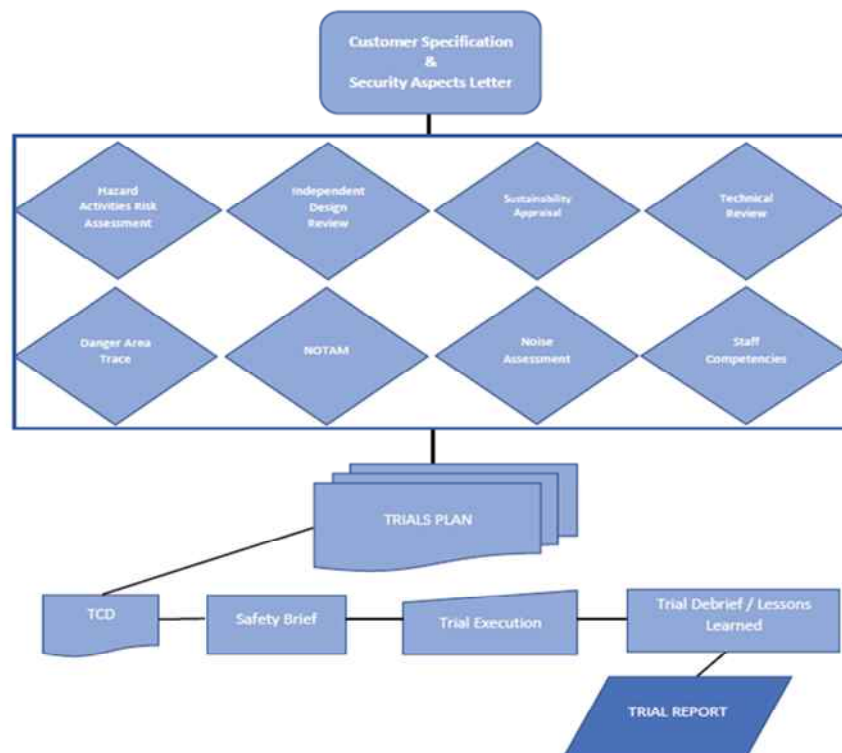

Fig 17 - 2. Trial Process

17-27. **Trial Documentation.** The Trials Manager (TM) shall co-ordinate the trials documentation that will include, as a minimum, all relevant RA, work instructions, Range Standing Orders. The tasking authority is responsible for producing the trials requirement/specification and supporting technical and safety data. Trials documentation shall be approved by the HoS/providing manager prior to the trial commencing.

17-28. Medical.

- a. On TERP ranges where explosive trials are conducted, the number of trauma trained first aiders must be based on an assessment of risk that includes location and availability. Management of employees tasked on trials activities must endeavour to keep at least one trauma trained first aider out of any potentially dangerous environment so they can administer first aid in the event of an accident. There must

¹⁵ Dstl broadly follow this process.

always be at least one trauma trained first aider available when explosive trials are taking place, including out-of-hours trials. Where other dangerous materials are present, during a trial, the specific medical provisions for an incident involving such materials must be considered, e.g. phosphorus burns.

b. The communication system used for summoning medical assistance must be at the trials location and tested prior to the commencement of the trial.

17-29. **Military Training.**

a. **Control and Supervision.** In all cases, the training is to be controlled, and supervised where necessary, by competent personnel appointed by the Service Unit involved. In parallel with this the overall range activity is to be monitored by SQEP provided by the MOD. Military units conducting TLB authorised/sponsored activities on TERP ranges shall confirm to all service regulatory requirements and Duty Holding responsibilities/ accountabilities. Advice, where required, should be sought from the RAU.

b. **Documentation.** The Service Unit is responsible for writing and distributing the Exercise Documentation, which must reflect the practices agreed with the RAU.

c. **Medical.** Military units must comply with the minimum medical requirement table prescribed in Chapter 2 of Pamphlet 21 or similar service guidance.

Laser Trials¹⁶

17-30. **General.** The MOD' is responsible for ensuring that all laser use, training, testing, research, and trials are conducted in a safe manner which complies with or exceeds the requirements of UK Health and Safety legislation. This is of particular importance for evolutions involving the use of lasers as TERP ranges are often used for trialling new equipment. Careful note should be taken during the trials planning process of the class of Laser to be used and the corresponding properties and hazards (see Table 17-4).

17-31. **Laser Safety Officer (LSO).** A Trial LSO is to be appointed by the HoS in order to co-ordinate laser safety where lasers are in use. Where the only laser devices held within a Site are Class 1 or Class 2, an LSO does not need to be appointed. The duties of an LSO are detailed in para 8 of DSA 03.OME Part 5 - DCOP 502 Series.

17-32. **Laser Safety Certification.** Laser operators shall ensure that a valid certificate (Military Laser System Safety Assessment Certificate (MLSSAC)) has been obtained and in place before a laser system can be brought into service or prior to the commencement of a laser activity. Military lasers falling under the classifications Class 1, Class 1M, Class 2, Class 2M, Class 3R, Class 3B and Class 4 according to IEC 60825-1 will require certification by a Military Laser Safety Advisor by the Military Laser Safety Team (MLST); see Table 4 for the classifications and hazards.

¹⁶ DSA 03.OME Part 5 Lasers – Defence Code of Practice (DCOP) 502 Series – Notifications.

Table 17-4 - Laser Classifications and Hazards

Class of Laser	Properties and Hazards
1	No risk to eyes, (including use of optical viewing instruments such as binoculars). No risk to skin. Lasers that are safe, including long-term direct intrabeam viewing. Class 1 lasers also include high-power lasers that are fully enclosed so that no radiation is accessible during use.
1M	No risk to the naked eyes, no risk to skin. Lasers that are safe for unaided eye, including long-term intrabeam viewing. Eye injury may occur following exposure with viewing instruments including binoculars.
2	No risk to eyes for short exposure times (including the use of viewing instruments). No risk to skin. These are lasers emitting radiation in the visible range (400-700nm) with the aversion response to bright light usually limiting the duration of the exposure. Therefore, they are considered safe for usual exposure situations, but are potentially hazardous for intentional staring into the beam. These lasers may cause dazzle and flash blindness.
2M	No risk to naked eyes for short time exposures. No risk to skin. Visible lasers are safe for short time exposures only for the naked eye. Eye injury may occur when using optical viewing instruments such as binoculars. They may present a dazzle or flash blindness hazard.
3R	Low risk to eyes. No risk to skin. Low risk for eye injury provided that only accidental exposure occurs. Emission levels higher than class 1 & 2 and could result in an eye injury when intentional intrabeam viewing occurs. If visible they could be a dazzle hazard.
3B	Medium to high risk to eyes. Low risk to skin. Lasers for which intrabeam exposure is hazardous, including accidental exposures, but for which the viewing of diffuse reflections is normally safe.
4	High risk to eyes and skin. Lasers for which intrabeam viewing and skin exposure is hazardous and for which the viewing of diffuse reflections may be hazardous. These also often represent a fire hazard.
3R, 3B, 4	<p>Range certification applies to MOD ranges, GoCo operated MOD Ranges and other MOD establishments such as Fieldcraft Training Areas (FTAs) and airfields. If the hazard distance template stated in the user handbook or MLSSAC does not fit within the range or training area boundary, or there are no control measures in place to ensure non-authorized personnel cannot enter the laser hazard zone, a Military Laser Range Safety Clearance Certificate (MLRSCC) MOD Form 2238B will be required. Should the exclusion template fit within the training area boundary and controls are in place, a MLRSCC will not be required. If unsure, the MLST can give advice on range certification</p> <p>For Air-to-Ground designation, there are certain limitations depending on the class of the laser and associated hazards distances. For further detail please contact the MLST for assistance.</p> <p>Class 1 and Class 2 lasers can be used on and off range without any restrictions, but operators should be aware of the risk of dazzle for visible lasers. All other laser classes have some restrictions associated with them. For further information please contact the MLST for assistance: deswpnswts-lo@mod.gov.uk</p>
Requirement	In the case of all trials on MOD ranges and DTAs, a Military Laser Trial Safety Clearance Certificate (MLTSCC) MOD Form 2238A will be required to be issued by the MLST unless only operating with Class 1 & Class 2 lasers

Remotely Piloted Air Systems (RPAS) / Uncrewed Aircraft Systems (UAS)¹⁷

17-33. **MOD Policy.** The operation of a RPAS/UAS should be no more likely to cause injury or fatality to personnel or the public than the operation of a crewed aircraft. The design criteria for a particular RPAS/UAS are to consider its intrinsic safety, its mode of operation and the environment in which it operates. The criteria apply to all RPAS/UAS operated by the Services or appointed contractors.

17-34. One of two governing bodies governs operation of RPAS/UAS within the constraints of an MOD range:

- a. **Civil Registered RPAS/UAS.** The maintenance and continued airworthiness aspects of aircraft is under the governance of the CAA, the operation of the aircraft at the Range will be carried out within the local procedures and the Type Certificate / Permit to Fly of the aircraft.
- b. **Military Registered RPAS/UAS.** Under the governance of the MAA in accordance with the Military Regulatory Publications (MRP)¹⁸. The operation of such aircraft, in the MOD range environment, is conducted in accordance with the local procedure pertinent to that range.

17-35. **Only Aerial Targets endorsed by the appropriate regulator (MAA/CAA), such as those in Combined Aerial Targets Service (CATS) are to be used on MOD TERP ranges. All use of RPAS must be approved by the RAO.**

Air-to-Surface Engagements

17-36. Air-to-Surface engagements for both fixed and rotary wing shall follow the instructions in DSA 03.OME Part 3 – Defence Code of Practice (DCOP) for Ranges.

Air Ranges

17-37. **General.** Ranges used for surface-to-air firings vary in the facilities that they can offer depending on whether they are single or multi-function ranges. TERP ranges are configured to contain the effects of a greater spread of events than a range established for training with an in-service weapon system. The sophistication of equipment that is deployed to support such firings is far superior to that on the training range, but this does not mean that the risks involved in such firings will be any less.

17-38. **Facilities.** TERP ranges have sea and air surveillance radars, tracking radars, optical trackers, thermal-imaging and high-speed cameras. These facilities deploy to monitor the major elements in the firing of a live or inert round. They can therefore monitor independently the launcher system(s), the missile(s), the target(s) and the major parts of any debris after warhead event. TERP activities are prepared and conducted within a SMS that mandates a full risk assessment leading to the risk of harm being reduced to Tolerable and ALARP. Where Service firings for training purposes are carried out on TERP ranges, local conduct and control is exercised by the user unit, but in accordance with the ranges SMS, which will include attention to Range Standing Orders and will require a practice or trials specification.

¹⁷ DSA 03.OME Part 3 Volume 3 Part 1, Chapter 6 – Uncrewed Aircraft Systems.

¹⁸ MAA Regulatory Article 1600.

MOD Staff Operating Commercial Ranges

17-39. **General.** Before a Civilian TERP Range is contracted to undertake TERP trials the relevant MOD TLB / Agency is to satisfy itself that the Range Owner / Operator has sufficient competency, expertise, and suitable facilities to undertake the TERP activity. This assurance is to be gained by a formal Audit / Inspection of the capability (with the agreement of the civilian owner(s) / operators) by suitable competent staff from the contracting organisation.

17-40. **Range Safety Management System.** TERP ranges owned and run by independent commercial organisations, that undertake work for MOD and its agencies; must as a minimum, have a robust safety management system that complies with all extant UK HS&E legislative requirements. The range owner / operator shall be able to demonstrate an acceptable means of compliance detailed in DSA Range Regulations by maintaining Safe Place, Safe people, Safe Practice and Safe equipment. The range Audit / Inspection is to include a comprehensive review of the Range Safety Management System including mandatory legislation, procedures, and Range Orders, to ensure the safety of all Range users and those who may be affected by its activities.

17-41. **Authorisation.** If the Range is suitable and meets the contractual requirements of the MOD TLB / Agency, then the Range may be authorised for use for TERP activities. While there is no requirement for the MOD to authorise the Range the MOD TLB / Agency should record the findings of the Inspection and detail the extent of authorised activities for future reference and audit.

17-42. **Audit / Review.** Following Authorisation for Use being issued by the MOD TLB / Agency, the Range Safety Management System is to be audited and reviewed annually with the agreement of the owner(s) / operator(s) to ensure the continuing safety of the Range for contracted activities. The findings of the Audit / Inspection are to be recorded for future reference. The records are to be retained for 10 years.

Safeguarding¹⁹

17-43. MOD safeguarding ensures operational facilities such as aerodromes, explosive stores, radar facilities and range areas are not compromised by either onshore or offshore development. MOD is engaged on development proposals, including those for wind turbines through a formal consultation process.

17-44. **Statutory Safeguarding.** MOD safeguarding represents the MOD as a statutory consultee in the UK planning system to ensure designated zones around key operational defence sites such as aerodromes, explosive storage sites, air weapon ranges, technical sites and meteorological radar sites are not adversely affected by development outside the MOD estate.

17-45. **Offshore.** The MOD is also a consultee on the licensing of marine developments and the extraction of hydrocarbon resources in the UK continental shelf area, to ensure offshore developments and activities do not affect strategic defence interests or inhibit the use of designated danger and exercise areas supporting military training and weapon trials.

¹⁹ The town and country planning (safeguarded aerodromes, technical sites and military explosives storage areas) direction 2002, updated 22 Dec 2016.

17-46. **Wind Farms.** Interruptions or delays caused by airspace incursion impact directly on complex and expensive airborne and surface trials, often involving multiple assets and which frequently take weeks to plan and execute due to exacting weather and operational considerations. It is an integral requirement for the safeguarding of all airspace users that the range controllers can maintain full situation awareness of the airspace within, and adjacent to, the danger areas in use. The MOD can negotiate protocols with operators of commercial windfarms to mitigate their effect on situational awareness and by extension, Range Safety.

17-47. **Safeguarding Areas.** Major areas for a safeguarding process for a TERP range are:

- a. **Explosives²⁰** - There are two types of Explosive Safeguarding Maps (ESMs).
 - (1) **Registered** – Where part of the SG area falls outside the MOD boundary and the ESM is registered by DIO with the Local Planning Authority (LPA).
 - (2) **Unregistered** - Where the SG area lies entirely within the MOD boundary, thereby only blighting MOD property so does not require registering with DIO or the LPA.
- b. **HSE licenced Facility.** A 'HSE Safeguarding Map' is to be lodged with the LPA. Consideration should be given to the area covered by this map and where possible the MOD safeguarding map should be made to fit this area.
- c. **Radars.** Both air and sea surveillance radars are susceptible to external interference or false signals returns. When a technical assessment indicates the proposed development is in radar line of sight to a surveillance asset and / or recording equipment, an operational assessment by several Subject Matter Experts (SMEs) with experience in the following areas:
 - (1) Radar propagation and electronic warfare.
 - (2) Operational capability.
 - (3) Air Traffic Control Services and Air Battlespace Management.
 - (4) Datalink Behaviour.
 - (5) Local Topography.
- d. **Airfields - Outside MOD Property²¹** DIO Safeguarding publishes an official safeguarding map (Official Safeguarding Plan) which is issued to County and Local Planning Authorities and to certain other bodies.

Environment

17-48. **General.** On TERP ranges operated by Dstl or by a contractor for DE&S an assessment of the effect on environmental impact shall be made before each separate event or activity is undertaken. SME organisations within DIO are available to advise and assist and should be tasked following the process detailed in para 17-29. **The RAU must**

²⁰ DSA 03.OME Part 2 Chapter 22.

²¹ Regulatory Article 3590(8) dated 29 Mar 2019.

be notified of any potential environmental impact caused by trials activities, during the planning process.

Noise

17-49. **General.** Statutory Nuisance is a class of pollutant defined by the Environmental Protection Act 1990. For a nuisance to be classed as statutory it must be considered regular and frequent. Defence has an exemption in relation to Statutory Nuisance relating to smoke, artificial light, and noise (this exemption extends to Scotland). However, it is MOD policy²² to comply with several aims of the legislation covering noise nuisance and outlines the requirement to maintain good relationships with neighbours, advising them of likely disturbances, dealing with any complaints sympathetically with a prompt and comprehensive response and minimising noise events as far as is reasonably practicable.

17-50. **Noise Regulations.** In the UK, Control of Noise at Work Regulations 2005 (the Noise Regulations), implements the European Physical Agents Noise Directive - 2003/10/EC which came into force in April 2006, and replaced the Noise at Work Regulations 1989. The Noise Regulations include lower exposure action values, upper exposure action values, and exposure limit values, as shown in Table 5 below. The maximum emission level of 140dB is taken from the Control of Noise at Work Regulations 2005, Exposure Limit Value. Exceeding this level would be unacceptable for the general public.

Table 17-5 – 2005 Noise Level Parameters

	Lower Exposure Action Value	Higher Exposure Action Value	Exposure Limit Value
Continuous Noise (A)	80dB leq	85dB leq	87dB leq
Peak Sound Pressure (Impulse Noise) (C)	135dB	137dB	140dB

17-51. **TERP Ranges.** Due to the nature of work conducted on TERP ranges, a self-imposed limit of 130dB could critically restrict some activities. Guidance for TERP ranges is also contained in JSP 418²³. Activities conducted on TERP ranges shall comply with the following parameters:

- a. Activities comply with MOD policies or the appropriate legislation, whichever is the more stringent; activities are in accordance with any local restrictions imposed on the range. Assessments of potential noise disturbance are conducted before any impulse noise producing activity is permitted. Appropriate assessments are calculated using gunfire assessment software to establish the potential disturbance to neighbours and that appropriate measures taken to mitigate the disturbance. See an example of an Acoustic Forecast at Fig 2 that illustrates noise prediction around the area of the weapon, the Range boundary and direction of the noise pattern.
- b. **130dB.** The limitation of 130dB is routinely restricted at the Range Boundary. The RAU can authorise noise limits up to 135 dB except certain sites that have an

²² JSP 418 - Management of Environmental Protection in Defence.

²³ JSP 418 - MOD Corporate Environmental Protection Manual, Leaflet 4.1 – Environmental Noise, page 6, para 18.

enforced limitation due to the highly populated surrounding area. Acoustic monitoring is to be maintained throughout the activity.

c. **>135dB.** Approval from the RAU is required for any impulse noise exceeding 135dB to a limit of 140dB. Applications and approvals are to follow RAU/HoE procedures and records kept of acoustic recordings. Acoustic monitoring is to be maintained throughout the activity.

d. **>140dB.** If any work being planned is likely to breach 140dB, Ministerial dispensation must be sought by the range operator, following the recognised and approved RAU/HoE secretariat procedures.

17-52. New OME Systems. Noise levels shall be assessed during the development phase are to be made available to the range operator to enable noise predictions to be made.

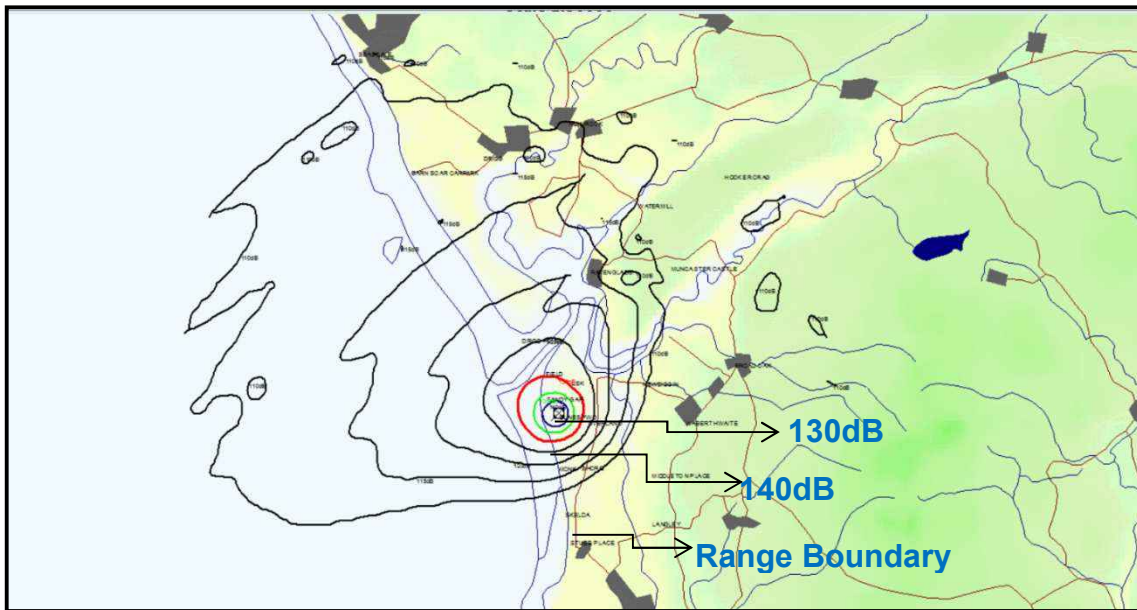

Fig 17 - 3. Acoustic Forecast

17-53. Sustainability

a. Ranges are to have an environmental management system in accordance with JSP 418, or in the case of contractor operated ranges a company policy, which supports a structure within which environmental management, sustainable development, legislative compliance, and continual improvement, can be managed.

b. The policy driver for undertaking Sustainability Appraisals (SA) on MOD plans, programmes and projects re-confirms the MOD commitment to adhering to relevant legislation specifying sustainability or environmental appraisals. This guidance and the mandate are applicable across MOD, including Contractors, Partners, Trading Funds and Agencies. Current policy is to carry out sustainability appraisals and environmental assessments, as appropriate, for new or revised policies, programmes (including acquisition programmes), office relocations, new projects, and training activities.

17-54. **Marine Mammal Consideration.** Care must be taken to protect marine mammals from serious injury, death or anxiety that may be caused by them being in the proximity of

UNCONTROLLED COPY WHEN PRINTED

DSA 03.OME Pt 3 Vol 2 Ch 17

the Sea Danger Area (SDA). The operating unit will be principally responsible for providing Marine Mammal Observers. However, Range control staff also have a responsibility to observe the SDA and report any marine mammal sightings to the operating unit. In the event of identifying marine mammal activity within the Range area "Check Firing" by the observer, spotting the mammals and a watch kept until the mammals have exited the area and it is safe to resume the practice.

Chapter 18 - Grenade Ranges

The Standard Grenade Range. The basic training grenade range is a purpose-built structure for grenade practices up to Trained Soldier level prior to going on to tactical grenade throwing on Live Fire Tactical Training (LFTT) exercises.



18-01. **Description.** The standard grenade range has up to three throwing bays. To the left of the bays is a troop assembly building and to the right a dispersal building for those who have practised. An impact area of approximately 41 x 21m is forward of the throwing bays and behind them is a protected tower designed to provide clear unobstructed observation into the throwing bays and protection for the RCO.

18-02. **Purpose.** This range is for initial and refresher training. It cannot provide realistic operational or advanced training.

Range Danger Areas

18-03. The RDA has a radius of 250m extending all-round the impact area (see Fig 18 - 1). The current grenade, L109 has a danger area of 200m from point of detonation. The impact area must be open to view by the safety supervisors in the throwing bays. The DA should be clear and open to view from the RCO's control tower; where this is not possible, control measures must be in place which allows the RCO to be confident that the DA is clear. It may be necessary to post sentries to cover blind spots. An area to the flanks of the prepared impact area extending 20m beyond the prepared impact area must be kept well maintained to locate and clear any blind grenade thrown wide. Movement within the RDA beyond the clear area is to be restricted due to the possibility of blinds unless that area can be cleared by the RCO following the destruction of a blind. When using red phosphorous grenades RCO's must ensure the wind direction will not endanger those on the range as set out in the General Service Publication (GSP).

Design

18-04. **Design Criteria.** The constructional details for the grenade range are shown in Fig 18 - 1. The range was designed for previous issue L2 grenade but is suitable for currently approved L109 Service hand grenades. The standard design includes sloping roofs on the assembly and dispersal buildings with the slope towards the impact area to avoid any

ponding on the roof. Ponding can enhance the blast effect of grenades thrown onto these roofs and therefore could damage the roof.

18-05. **Siting.** The range buildings and impact area require a reasonably level site as there must be no possibility of a grenade rolling after it lands whether deliberately thrown or accidentally dropped. The range should be sited away from roads and areas frequented by the public. The orientation of the range should be northerly so that the RCO is not looking into the sun.

Construction

Range Floor

18-06. **Impact Area.** The grenade range floor of 41m long by 21m wide is to be constructed, as an essential safety function of the surface, such that blinds can be easily located and destroyed whilst minimising the blast and fragmentation effects. To achieve this the range floor needs to be stable, resulting from good mechanical interlock of the aggregate, with the aggregate sized such that there are no gaps large enough for a grenade to fall into. The range floor should have the following properties:

- a. Minimum depth of 300mm of aggregate, on top of a compacted hardcore base with a minimum depth of 300mm. The required specification of the aggregate is 20mm – 40mm, it is recommended that a minimum of BS 13043:20/40Gc85/20 igneous based rock (Granite, Dolerite or Basalt), with an LA Factor less than 20 and a point load strength greater than 4 (batch average) is used.
- b. Graded and maintained level with an even mix of the different sized aggregate.
- c. Free draining and flat to avoid ponding.
- d. Free from debris and materials other than those used to construct the range floor, fragments of targetry or expended grenades.

18-07. **Fences, Signs and Flags / Lights.** A suitable fence may be provided. Flags / lights and warning signs, particularly UXO signs (refer to Fig 2 - 14) are provided around the DA in accordance with Chapter 2.

Range Buildings

18-08. **Throwing and Issue / Priming Bays.** Although the Fig 18 - 1 shows a layout with two throwing bays, the number may be varied from one to three, three being the maximum a RCO can effectively control. Each bay has sufficient space for the thrower and a safety supervisor. An emergency exit is provided in addition to the entrance route in case a grenade is dropped on the floor. The gravel floor has a 100mm depth of 20mm single sized aggregate laid on a base of 40mm single sized aggregate 150mm deep with sub-soil drainage as required. This specification is essential to safety as it has been designed to stop a grenade rolling and to absorb blast and fragments. The walls of the bay are capped and clad with 25mm thickness softwood on the inside to absorb blast and fragments should a grenade detonate in the bay. To prevent ricochet the side wall timbers are to be fixed horizontally as vertical faces can generate ricochet when vertical boards warp. Also, the metal fixtures securing the cladding are to be countersunk or protected. The height of the wall from the gravel floor must be maintained at 1.35m to provide cover for the occupants from the grenade detonating on the impact area. An issue / priming bay is provided for each throwing bay.

18-09. **Assembly and Dispersal Buildings.** Roofed buildings at each end of the range structure are linked by the open throwing and priming bays. These provide shelter and briefing areas for troops not engaged in throwing and are fitted with benches. On some ranges the roof is used as an observation platform for trainees so that they can see into the throwing bays during the initial briefing and dry run through. Where this is the case, access and demountable safety barriers are to be provided. The roofs are constructed with a fall to the impact area and a parapet wall on the other three sides to ensure that a miss-thrown grenade remains on the roof and ponding which increases the blast effect of a grenade, is prevented. The walls of the assembly and dispersal buildings rise above the priming bay. This area of wall and roof overhang is timber clad with boards fixed horizontally to prevent splinters from the impact area ricocheting into the priming bay. It is essential that only softwood is used as plywood and similar materials are too hard. For the throwing bay, metal fastenings on the cladding are to be countersunk or protected.

18-10. **Control Tower.** A control tower of sufficient height is provided to ensure that the RCO has a clear view of activity in the throwing bays where there is more than one throwing bay, of all movement on the range, and of the impact and DAs. The RCO must be able to communicate and to command all troops on the range by voice or loud hailer. The control post on the tower must be protected on the three sides nearest the impact area by splinter-proof walls 1.350m high for the RCO to duck behind after observing the fall of the grenade. The viewing area above the walls must be open to allow splinters to pass through. Weather protection can be provided by light canvas screens in the upper portion, but they must not hinder the all-round view of the range; hatches or splinter-proof glazed panels hinder the RCO's work and are themselves a source of danger. The roof slopes down to the front so that grenade splinters will either hit the top or pass through and ricochet out of the tower to the rear. Columns supporting the roof must be timber or timber clad. Any roof supports should run front to rear to avoid backsplash surfaces above the RCO. A ladder or steps are provided at the back of the tower with a safety rail that closes after the RCO is in the tower. The tower structure from above the throwing bay wall height to the sill of the control post opening is clad in timber to prevent fragments ricocheting. The tower is provided, and has protection, for the RCO only.

Communications

18-11. A means of summoning the emergency services is to be available and a telephone point may be installed in the control post.

Maintenance

18-12. **General.** Grenade ranges are often isolated and may not have a dedicated Range Warden. Certain items of maintenance are essential to the safe operation of the range. These are:

- a. When inspecting the range, a visual inspection should be carried out to ensure the floor remains evenly graded and retains the properties described in paragraph 18-06. The certificate of the aggregate must be retained to prove the compliance of the aggregate which was procured.
- b. After each period of live training, the range structure is to be inspected for damage, particularly walls facing the impact area and the tower structure. Binoculars can assist in the latter.

- c. Gravel in the throwing and priming bays must be raked level and the height of the front wall kept at 1.35m. It will require occasional topping up with fresh single sized 20mm aggregate.
- d. The impact area surface must be levelled, and any displaced aggregate graded back into place. Aggregate that has broken down is to be removed and replaced with fresh aggregate. Aggregate displacement and degradation are usually caused by blinds being destroyed rather than thrown grenades detonating.
- e. Debris is not to be allowed to accumulate on any part of the range.
- f. Grass and vegetation in the RDA extending at least 20m around the impact area is to be kept short enabling RCO's to locate and clear any blinds landing wide of the prepared impact area. There is a legacy issue of blinds being thrown by the blind clearance charge out to 150m. Where there is not already control measures around the RDA to prevent access and until such time as the RDA is cleared by EOC, also revised measures in Pamphlet 21 to contain blinds on the impact area, the RDA out to 150m minimum is to be treated as a controlled impact area.

18-13. **Property Management.** Buildings, particularly the tower, will require periodic structural checks and it is essential the area remains well drained. Fencing and signs need to be checked at the same time.

Compliance Checks

18-14. The following should be checked:

- a. Authorised ammunition and practices.
- b. Correctly constructed elements including buildings and range floor as described in this Chapter.
- c. DA is appropriately controlled.

Not to Scale
Not to be Copied

All dimension in metres unless otherwise stated

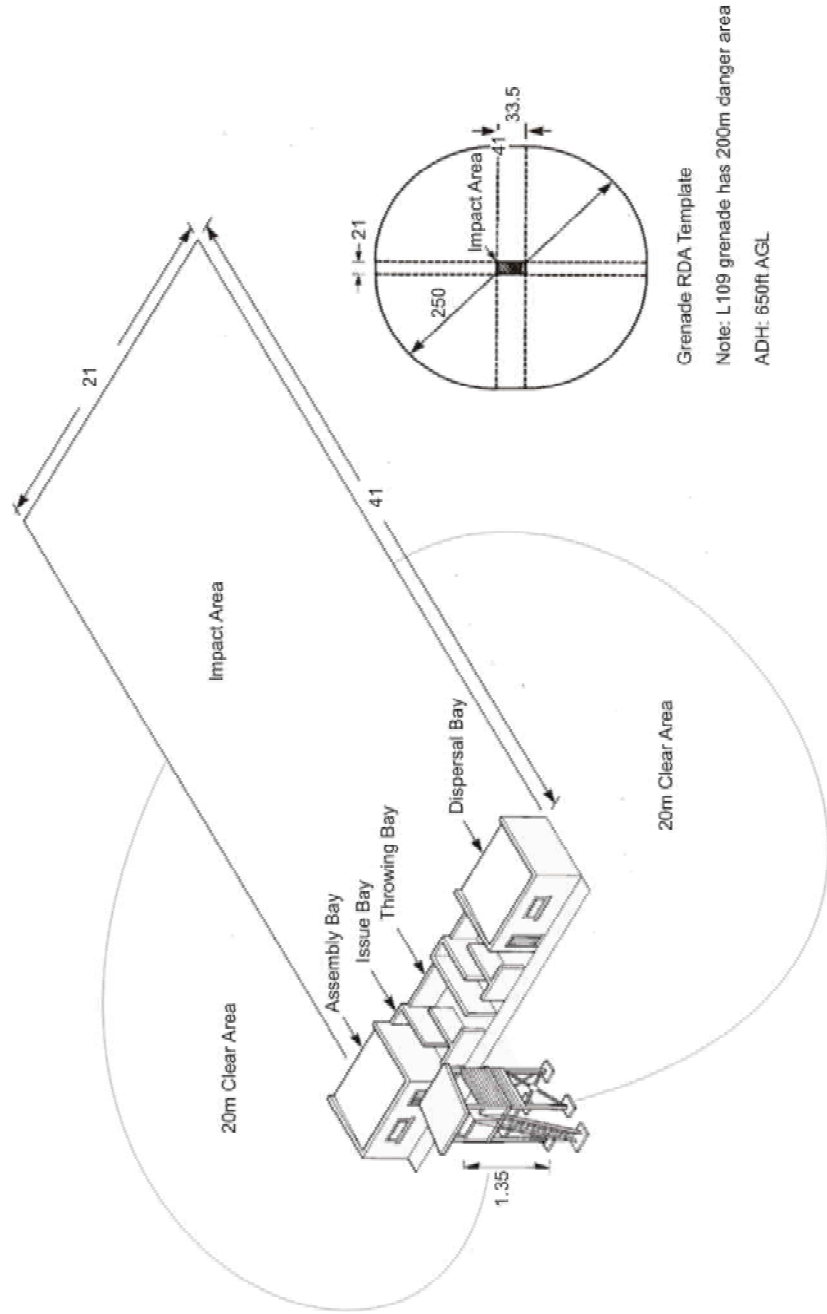

Fig 18 - 1. Layout and RDA Template of a Grenade Range

Chapter 19 - Mortar Ranges

A Mortar range needs little, if any, permanent construction. Selection of the range and preparation of the firing points (mortar line) by the mortar detachment may be all that is required. However, on permanent training ranges it may be advantageous for some permanent construction to be undertaken. The status of the training area for firing mortars depends on the ammunition nature:

- a. HE and Smoke. These may only be fired on a designated range authorised in accordance with this DCOP.
- b. Para-Illuminating. This may be fired on a designated range or on military training areas.

This chapter describes the facilities that may be constructed on an indirect fire range subject to the approval of the RAU.



Range Danger Areas

19-01. **Weapon Danger Area Templates.** The currently approved WDA templates for Light and Medium Mortars are shown in the Figs to this Chapter. The conditions for applying the templates are set out in Pamphlet 21. However, the overhead mortar fire safety template (Fig 19 - 4) can only be used on ranges that permit this type of training (see Pamphlet 21). Any deviation in applying the WDA templates will require approval from Army HQ.

19-02. **Topography.** At extreme ranges the difference in height between the firing position and the target must be considered (Pamphlet 21).

19-03. **Impact Areas.** Refer to Chapter 2.

Construction

19-04. **Siting.** The area selected for a Mortar range must contain the WDA and should be large enough to exercise the Mortar platoon in fire and manoeuvre using, ideally, the maximum range of the weapons. The ADH and the requirement for notification as stated in Chapter 1 will need to be considered. In woodland, there must be sufficient muzzle clearance over the full arcs of fire at the mortar line.

19-05. **Targets.** There are no specific targets for Mortar ranges. They may be physical features, simulated defensive positions, Fig targets or vehicles. The target area should be firm and dry ground to reduce the number of blinds.

19-06. **Mortar Fire Controller Positions.** Mortar Fire Controller (MFC) positions on PTR may require prepared observation posts (OP) and surfaces for AFV.

19-07. **Mortar Lines.** Tactically, mortars will be positioned 40m apart, but this may be reduced to 10m if space is restricted. A permanent mortar line may require pre-positioned mortar positions and prepared sites or hides for AFV mounted mortars.

Communications

19-08. **External.** A means of summoning the emergency services, ideally a land laid telephone is to be available.

19-09. **Internal.** Radio or telephones must be provided between the RCO, MFC, mortar lines and range control. Permanent ranges will normally have their own range safety network.

Maintenance

19-10. Little maintenance is necessary on a Mortar range. Constructed positions, such as MFC and dug-in firing positions, require to be inspected and kept in a safe state. Clearing undergrowth, dead wood, litter, and debris reduces the fire risk.

All dimension in metres unless otherwise stated

**Not to Scale
Not to be Copied**

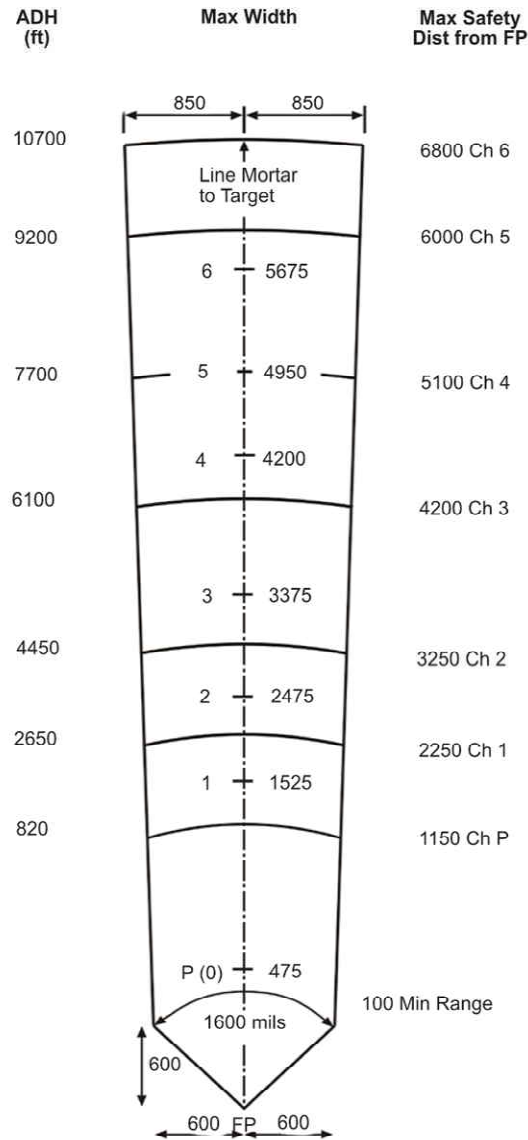

- Notes:
1. Charge Primary only to be fired on operations
 2. For use with service baseplate and the FV432

Fig 19 - 1. WDA Template, 81mm Mortar L41 & L42, Mk 4 Charge System NBSD

All dimension in metres unless otherwise stated

**Not to Scale
Not to be Copied**

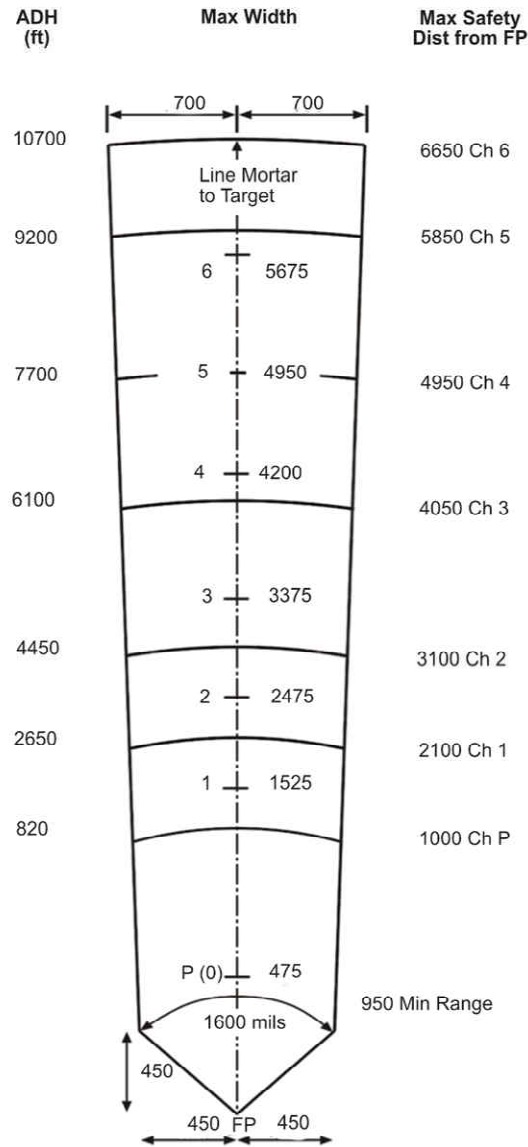

- Notes:
1. Charge Primary only to be fired on operations
 2. For use with service baseplate and the FV432

Fig 19 - 2. WDA Template, 81mm Mortar L41 & L42 Mk 4 Charge System -RBSD

All dimension in metres unless otherwise stated

**Not to Scale
Not to be Copied**

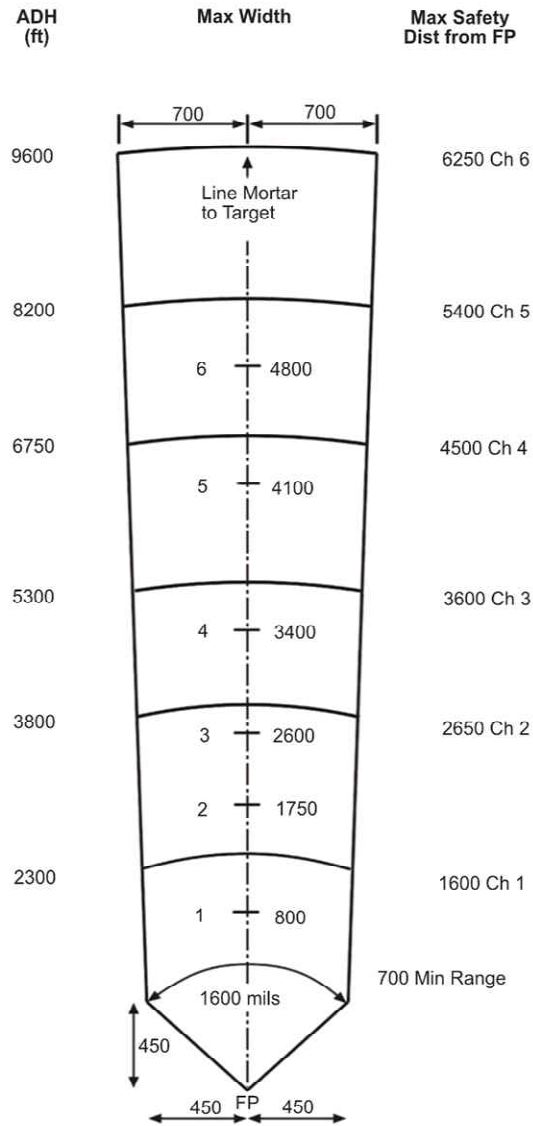

- Notes:
1. Charge Primary only to be fired on operations
 2. For use with service baseplate and the FV432.
 3. The template does not allow for the drift of the flare.

Fig 19 - 3. WDA Template 81mm Mortar L16, firing Round Illuminating L54 Mk 4 Charge System

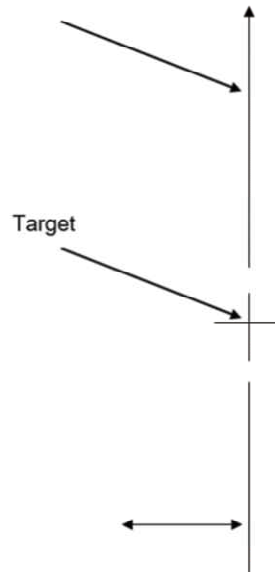

Charge	Normal (m)		Reduced (m)		Special (m)		Illum (m)	
	Length (a)	Width (b)	Length (a)	Width (b)	Length (a)	Width (b)	Length (a)	Width (b)
1	700	600	550	450	300	200	550	450
2	750	650	600	500	350	200	600	500
3	800	700	650	550	400	250	650	550
4	900	750	750	600	500	350	750	600
5	1000	800	850	650	600	350	850	650
6	1100	850	950	700	700	400	950	700

Notes

1. The overall dimensions of the Overhead Fire WDA are measured from the centre cross to the outer edges of the box for each charge
2. For use in the Ground Role and with FV 432 and BV 206.

Fig 19 - 4. 81mm Mortar Mk.4 Charge System Overhead Fire Weapon Danger Area (WDA) Data

All dimension in metres unless otherwise stated

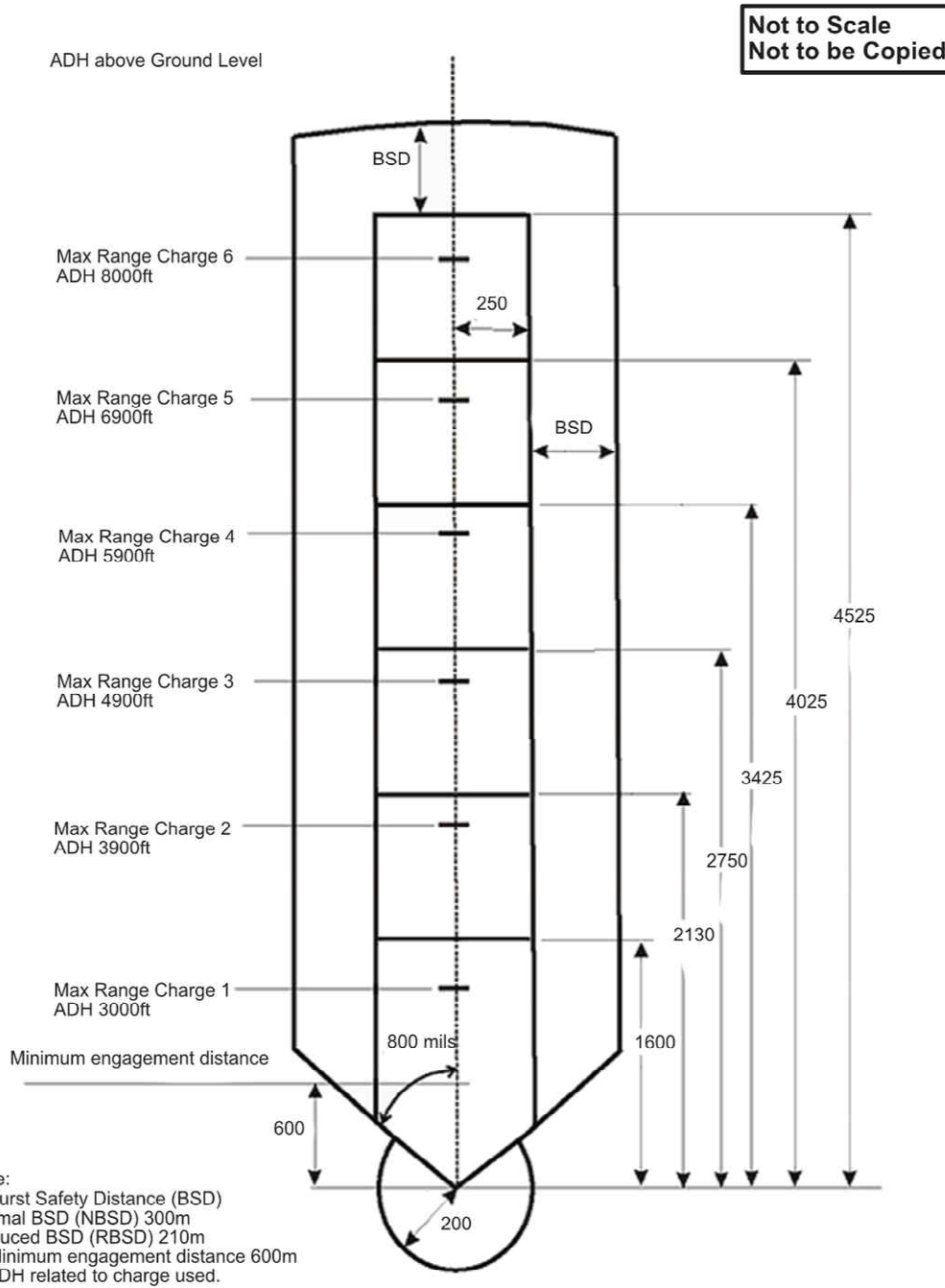
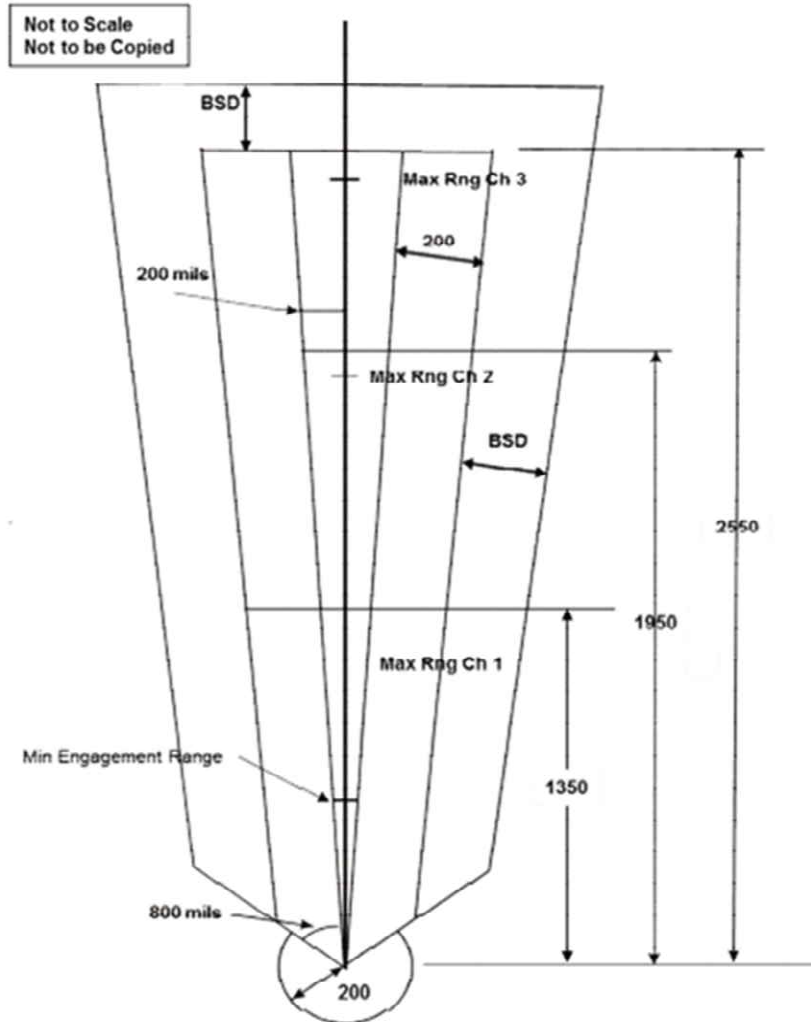

Fig 19 - 5. WDA Template, 60mm Mortar M224 Bipod Role



- Notes:
1. Burst Safety Distance (BSD)
Normal (NBSD) 300 m
Reduced (RBSD) 210 m
 2. Minimum Engagement Range 500m
 3. All dimensions in metres.
 4. Drawing not to scale.
 5. ADH 4800 ft.

Fig 19 - 6. WDA Template, 60mm Mortar M6-640 (Light Role)

Chapter 20 - Infantry Anti-Tank Weapon Ranges

This chapter sets out the range design and construction requirements for two infantry anti-tank weapon systems NLAW, Javelin. The ranges are likely to be suitable for existing and replacement weapon systems.



Section 1 NLAW

20-01. **General.** The NLAW is a rocket with a High Explosive Anti-Tank (HEAT) warhead. These weapons are designed for use in all environments and from suitable vehicle platforms.

Range Danger Areas

20-02. **Weapon Danger Area Template.** The WDA template for the NLAW HEAT round comprises of several elements (see Fig 20 -1).

- a. **Clear Zone.** The clear zone extending 220m forward from the firing point at an angle of 192mils either side of the LoF is to be clear of all obstructions that may initiate the missile including targets, trees, shrubs, or outcrops of rock.
- b. **Back Blast Area.** The Backblast area extends 20m behind the firer over an arc 450 (800 mils) either side of the LoF. The area must be flat or falling away from the firing point and completely clear of any obstructions (see Fig 20 - 2).
- c. **Burst Safety Distances (BSD).** The BSD is 150m. This captures the furthest risk of fragmentation to personnel; this is not to be reduced. The BSD for the NLAW will only extend from the sides and front of the WDA (see Fig 20 - 1). The only consideration needed for the rear is the Backblast Area are stated in the paragraph above Refer to Pamphlet 21 for the application and meaning of BSDs.

20-03. **Impact Areas.** The impact area is to be managed in accordance with controlled impact area procedures (refer to Chapter 2).

Siting

20-04. The site for a NLAW range must ensure that:

- a. There is an unobstructed LoS from the firing bay to each target.
- b. Targets are positioned so that misses detonate on a stop butt or rising ground behind the target.
- c. The backblast area should have no obstructions.
- d. The RCO should be best positioned to conduct practice safely.

Construction

20-05. **Targets.** Targets will normally be AFV hulks, but they may be solid simulations with a facing minimum thickness of 2.5mm metallic structure to ensure detonation. Targets should also be of substantial mass, when engaging with Overfly Top Attack (OTA) the NLAW weapons system relies on the metallic content of the target to initiate the warhead. Targets should therefore be whole and complete i.e. a tank with turret. Further details of anti-tank targets and movers are contained in Chapter 24. No target may be less than 220m from the firing bays, which is the minimum training engagement distance. Practice engagements with HEAT missiles may be fired at up to the battle engagement of 600m for static targets and 400m for moving targets.

20-06. **Initiating Stop Butt.** All-purpose built ranges shall have, and for all tactical firing every effort made to have, a bank or rising ground behind the targets to catch and initiate rounds which miss the target. If an initiating stop butt is to be constructed it is having a face angle of 270mils (15°) (S).

20-07. **Range Floor.** The range floor must provide a clear LoS to the target with no ridges or high points which could cause a missile to ground. Ideally it should be concave. Raising the target on a bank may also help.

20-08. **Purpose Built Ranges.** Up to three bays, the maximum an RCO can control, may be provided. Bays are constructed to protect firers and safety supervisors from the effects of an in-flight premature detonation of the missile and from the reflected noise off the firing bay wall. Bays are sited at least 10m apart either in a straight line or slightly angled to direct backblast away from adjacent bays (see Fig 20 - 3). The wall may be constructed in sandbags or 215mm hollow concrete blocks filled with 10kN /m² concrete and reinforced with 12.5mm MS bar. The weapon is fired through an aperture with raised side walls which provide additional protection to the safety supervisor. The high sound pressure level reflected from the wall is reduced by angling the upper section of the protective wall outwards. The protective wall may be constructed with revetted earth or sandbags or timber for the upper angled section. The floor and area behind are to be firm and level. The surface is to minimise obscuration and to provide a safe footing, for which dry lean concrete on a 150mm deep hardcore bed is suitable.

20-09. **Observation Post.** An open OP, normally a tower or raised platform, may be provided clear of the backblast area so that the RCO can conduct practices safely. The walls of the OP should be 1.35m high and those facing the firing point should provide a similar level of protection as at the firing point.

Tactical Firing

20-10. **Practice.** Procedures and best practice given in Pamphlet 21 shall be followed.

20-11. **Protection.** Firing must always take place from behind cover, which as a minimum shall be well compacted earth, 750mm wide, 750mm high and 1000mm long (per person to be protected). It can be a natural ground feature but if it is to be constructed advice and endorsement shall be obtained from RITT. Due to the launch characteristics of the missile, the need for 300mm clearance between the bottom of the launcher tube and ground or any obstruction for 50m in front of the launcher when firing from any fire position¹.

20-12. **Firing NLAW from a Confined Space.** NLAW can be fired from a confined space provided the structure is in a fit state The RAU shall satisfy themselves that the structure remains safe through the LoDA process including carefully monitoring the use of this facility to ensure it remains fit for use. The opening in the wall from which the missile is fired shall be at least 1000mm x 1000mm and 0.5m from the nearest wall. A rear wall backblast opening (anywhere on the rear wall) at least 1000mm x 2000mm must be present.

Section 2 JAVELIN

20-13. **General.** The JAVELIN is a guided missile which can be fired in the direct or top attack mode.

Range Danger Areas

20-14. Weapon Danger Area Template. The WDA for JAVELIN Block 0 is at Fig 20 - 4 and the Block 1 is a Fig 20 - 5 with the firing point danger zone illustrated at Fig 20 - 6 and 7.

Communications

20-15. . A means of summoning the emergency services, ideally a land laid telephone is to be available.

20-16. **Internal.** Telephones or radios are required between the CP, firing points and range controls.

Maintenance

20-17. **Responsibilities.** Maintenance is the responsibility of the RAU. Responsibilities may be divided as follows:

- a. **Property Management.**
 - (1) Grounds.
 - (2) Fencing and sign posting (may be DIO) (See Chapter 2).
 - (3) Structures, roads, and drainage including stability of slopes and erosion control.
 - (4) Water and electricity supplies.

¹ Guided Missile NLAW HEAT K170A1 and Associated Equipment para. 1-15. b.

(5) Periodic refurbishment of the range structure.

b. **Equipment Management.** Repairing and servicing equipment installed by single Service contract.

20-18. **Frequency.** Proper maintenance is dependent upon good liaison between the Range Warden and the RAU, and on properly scheduled maintenance periods. A heavily used range may need one day's maintenance each week plus one - or two days' maintenance by the Range Warden each month. Two closed periods of a week or so may be needed each year for building and earthworks repair; this work should be combined with the contract repair of equipment.

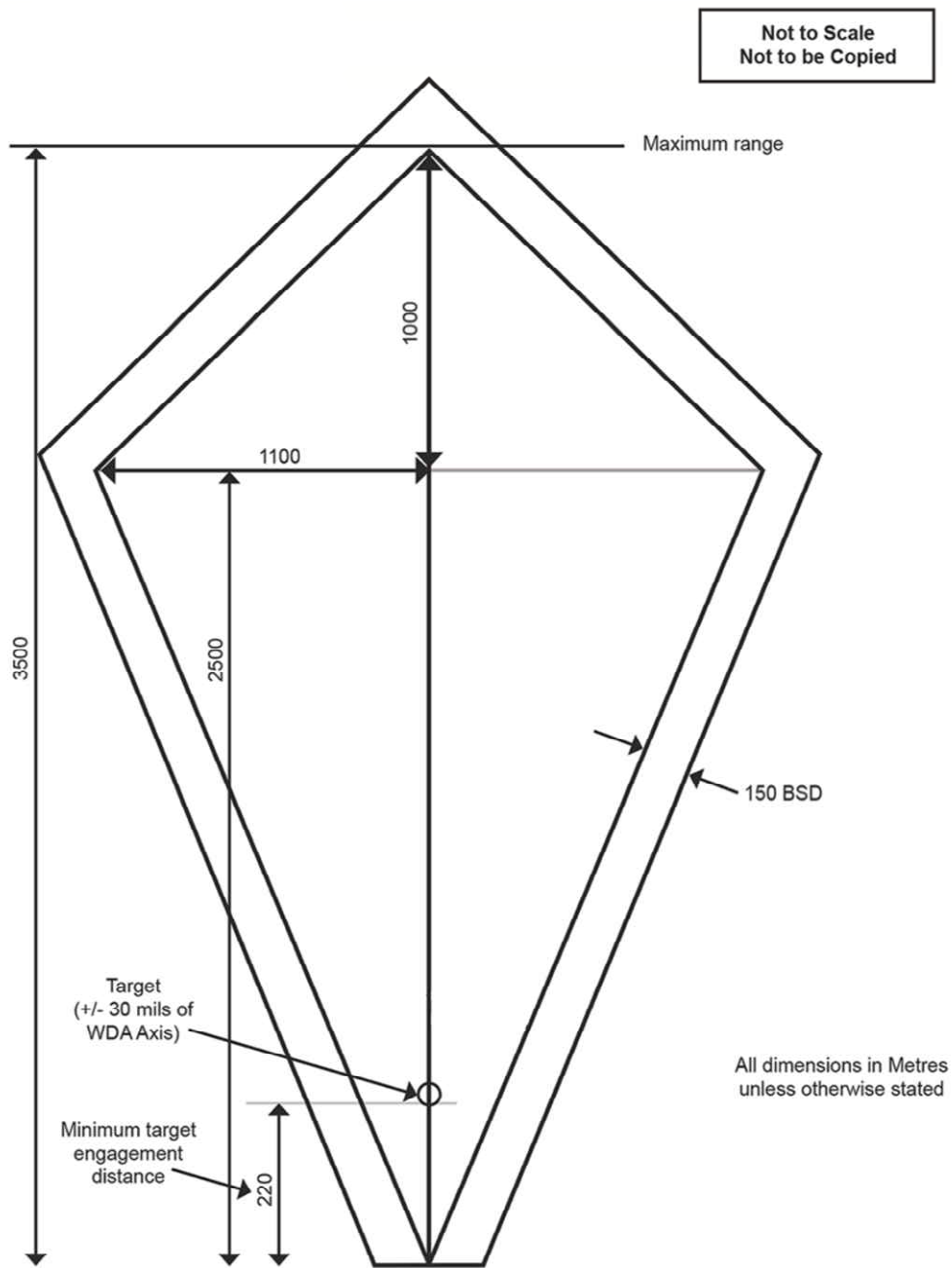

Notes:

- 1 ADH..3000 ft. AGL
2. Minimum target engagement distance - 220m with Arming Range Selector at 100m
3. **Restricted use - In Service Surveillance IGMR PT only.**

Fig 20 - 1. WDA Template NLAW HEAT

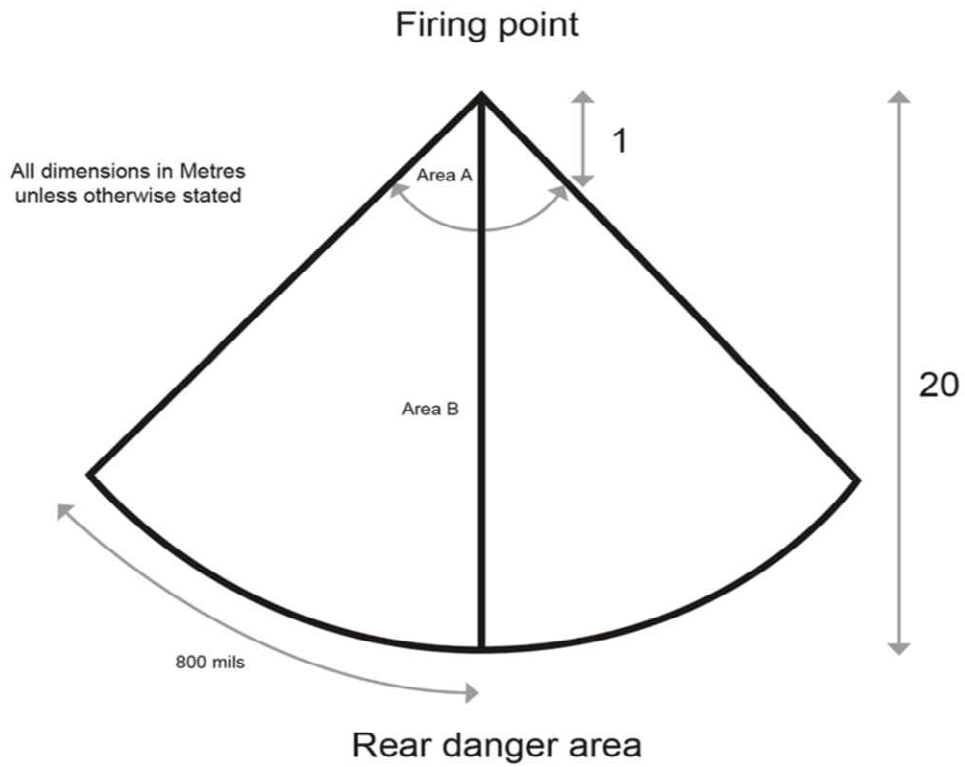

Area A - No large objects or walls
Area B - No personnel.

Fig 20 - 2. Rear Danger Area NLAW

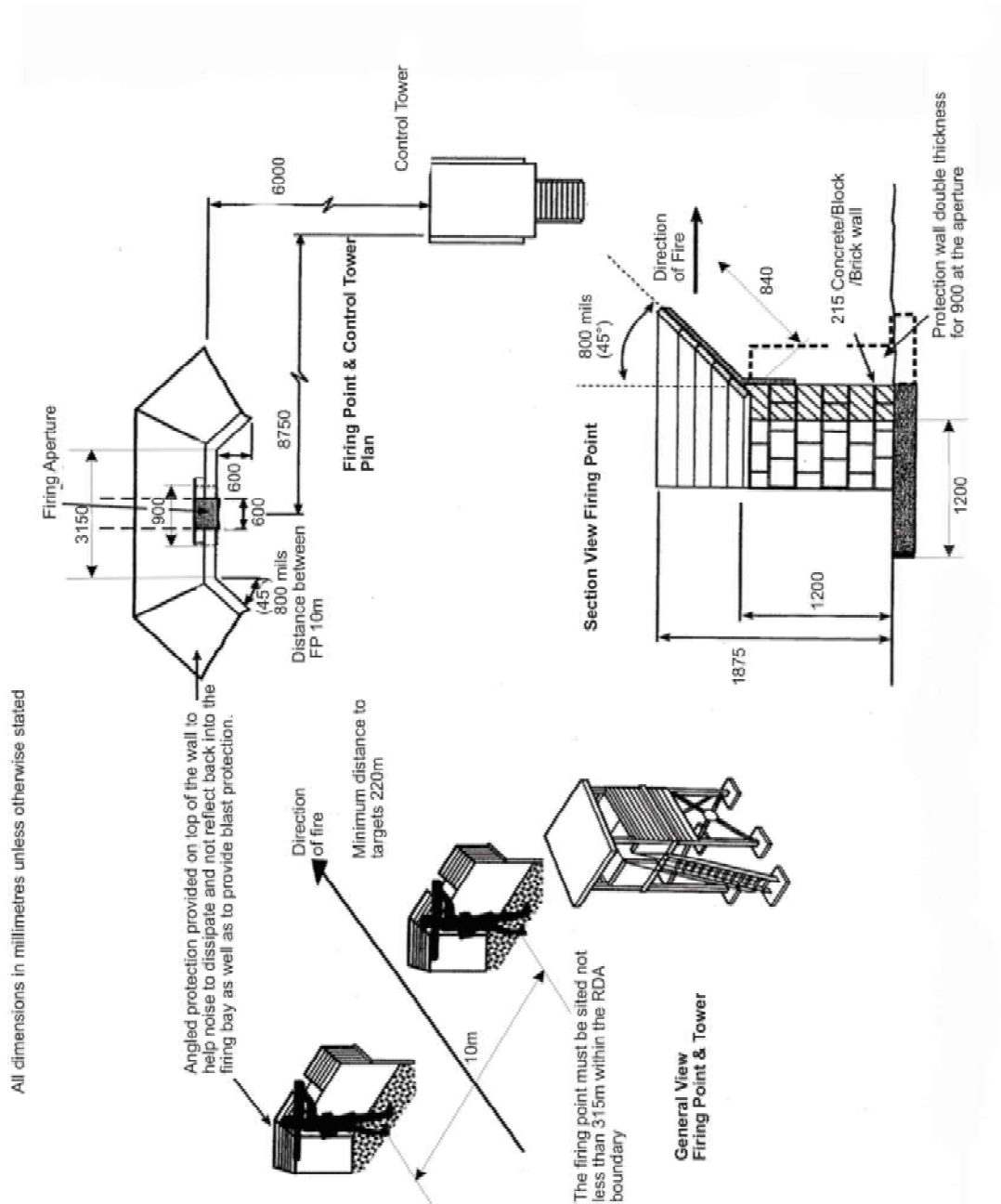

Fig 20 - 3. Anti-Tank Firing Weapon Point Layout and Detail

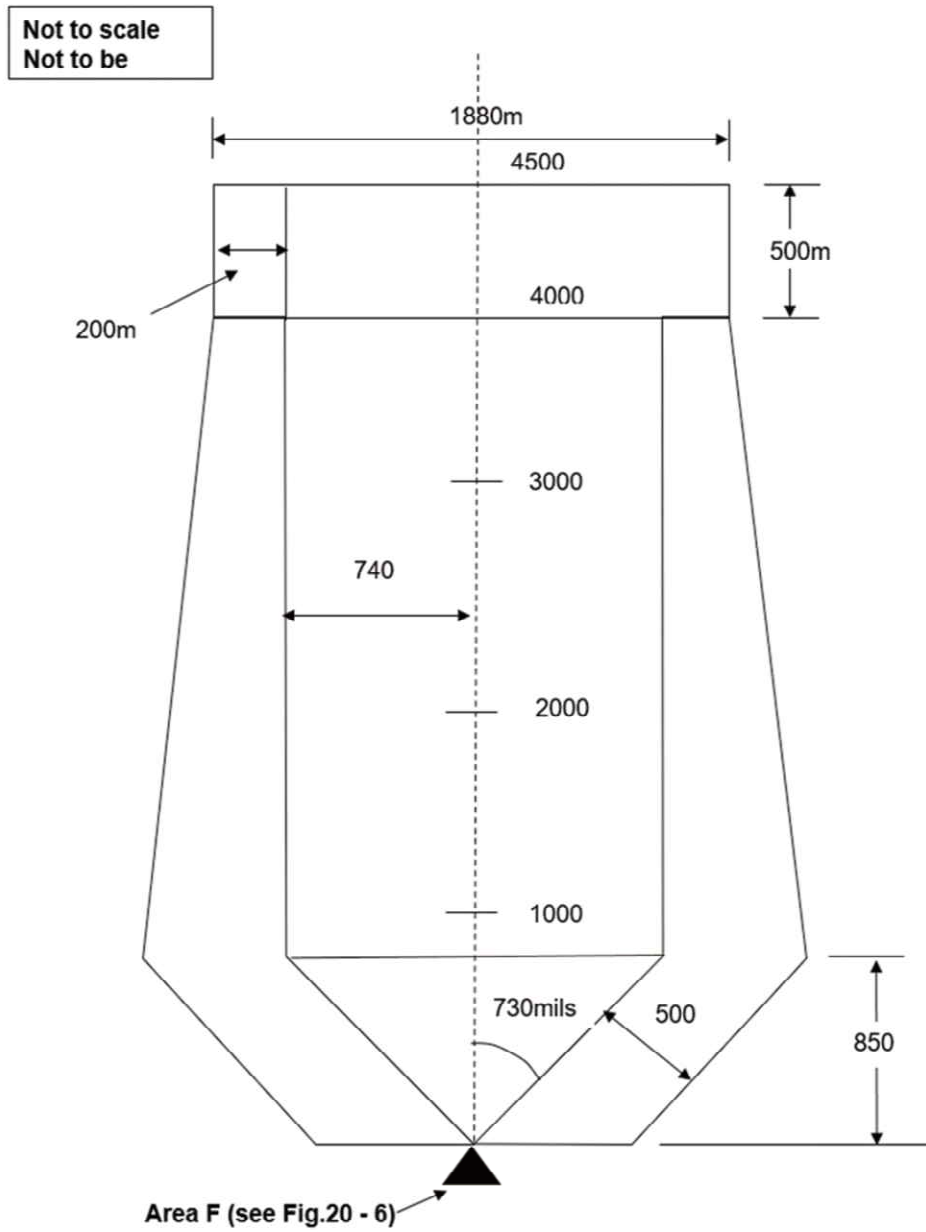

Fig 20 - 4. Weapon Danger Area (WDA) Template for Block 0 JAVELIN ATGW Using Missile Software V 8.06

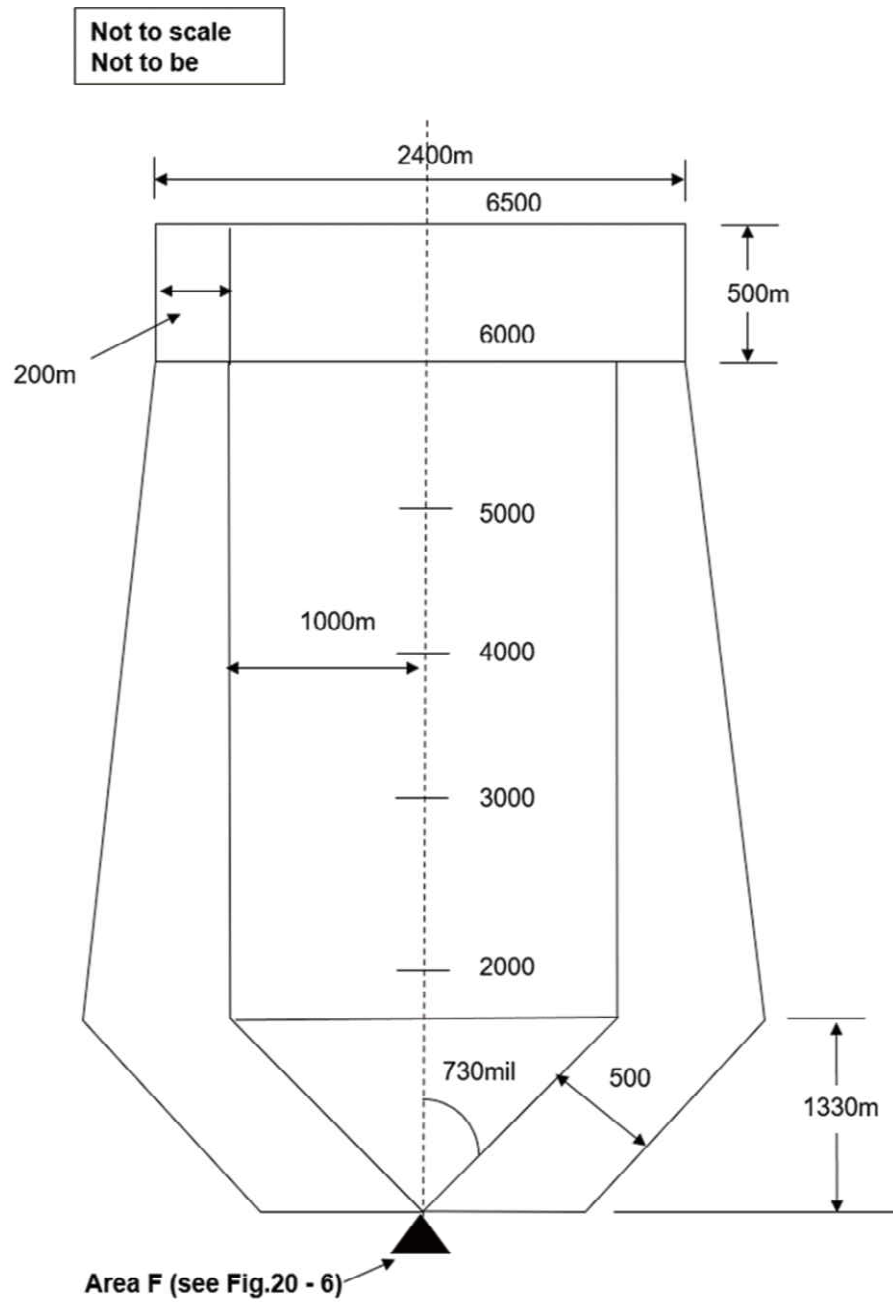
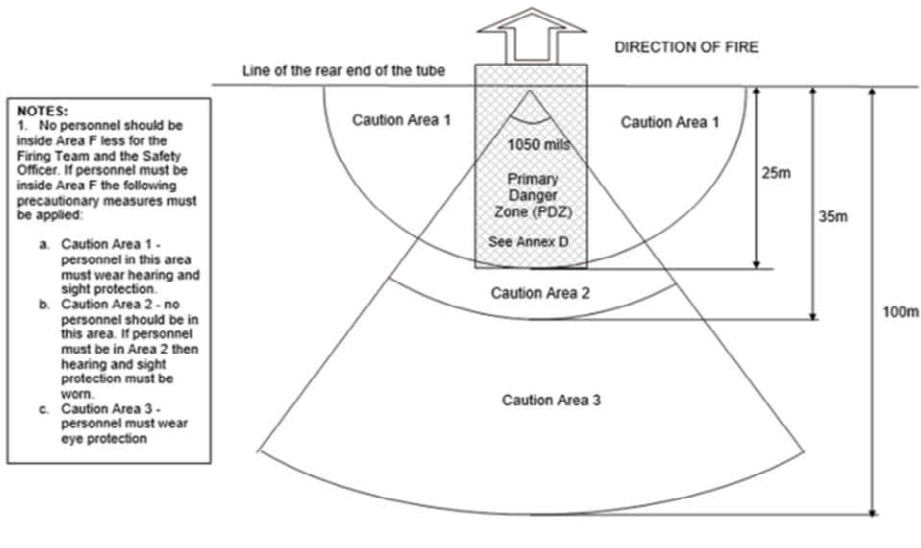

Fig 20 - 5. Weapon Danger Area (WDA) Template for Block 1 JAVELIN ATGW Using Missile Software V11.08



Note - 1050mils = 60° (approx.) to be applied either side of the tube, which give a total included angle of 2100mils (120°).

Fig 20 - 6. JAVELIN ATGW Area F

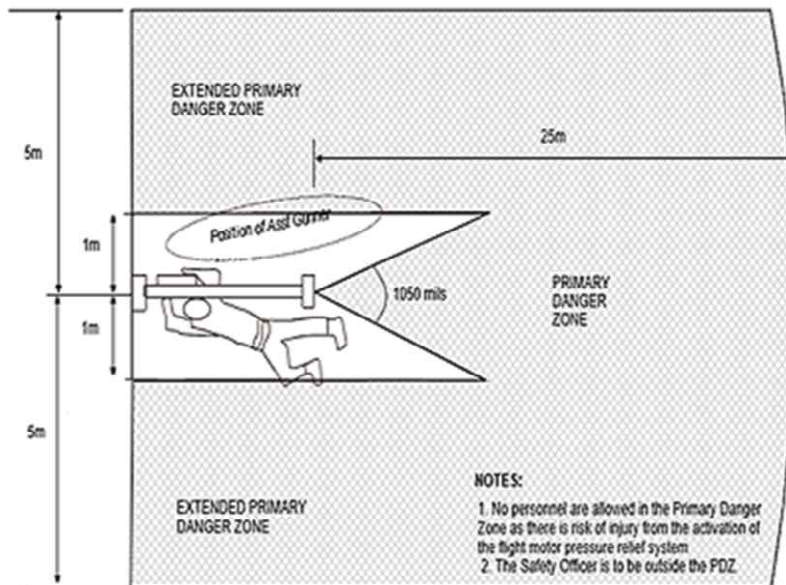

Fig 20 - 7. JAVELIN ATGW – Area F PDZ

Chapter 21 - Armoured Fighting Vehicle Weapon Systems

There are three types of ranges for Armoured Fighting Vehicle Weapon Systems (AFV WS) and the coaxial Machine Gun (MG) which are mounted on several types of AFV WS. These are:

- a. Static with fixed firing points for basic live firing practice, calibration, and in-service ammunition proof.
- b. Battle Runs for Fire and Manoeuvre Exercises (FMX). These can be conducted on fixed arc ranges of LFTTAs. The Royal Armament, Research and Development Establishment at Enfield (RARDEN) cannon is currently fired only when the AFV is stationary.

Battle Shooting which is part of LFTT and is temporarily set up on a LFTTA.



Range Danger Areas

21-01. The WDA templates for cannon ammunition natures including BSD are given in Figs 21 - 1 to 21 - 7. Those for the MG are given in Chapter 15.

AFV WS Fixed Arc Range

21-02. An AFV WS Fixed Arc Range is an open range primarily for use by AFVs, having no constructed bullet catchers, stop butts or backstops. There are designated arcs, manoeuvre lanes and firing positions / points and an impact area that can contain the full danger areas of authorised weapon systems, munitions, and explosives within the overall range boundary. Due to their size, these ranges may also be employed as LFTTA in accordance with local Range SOs.

Design and Construction

Static Ranges

21-03. A Static Range requires a smaller area than a Battle Run or Battle Shooting Range. A static firing line and a Battle Run has a hardened surface of concrete, asphalt concrete or compacted road stone to accommodate one or more AFV. It should be slightly raised above the surrounding ground and be flat with sufficient cross-fall to be free draining. The weapon danger area is applied from the furthest extents of the firing point upon which an AFV may be positioned. If several AFV firing lines are provided, the range is divided into lanes unless the RDA is large enough for cross-lane firing. Arcs of fire should be clearly

marked and be visible to both range staff and firing crews. They should be of a design which makes them stand out against their background and be regularly maintained to avoid being overgrown by foliage. For night firing, arc markers should be visible through conventional optical sighting systems, image intensifying sights and thermal imagers.

Battle Runs

21-04. **General.** The design of Battle Runs to provide Fire and Manoeuvre Exercises (FMX) will require detailed survey and planning. Such a range will only be possible on a considerable area of land or if a Sea Danger Area (SDA) is available. The RAU can design an AFV fixed arc range where ground is a limiting factor.

21-05. **Design Factors.** The following factors have to be considered in designing the range:

- a. Tactical scenarios to suit the ground.
- b. Target types and locations.
- c. AFV routes through the area.
- d. Earliest and latest points of engagement for each target.
- e. Establish the RDA by applying the WDA templates from each point of engagement to each target with specific arcs.

21-06. **Impact Area and Targetry.** For impact areas refer to Chapter 2. Targets for both cannon and MG may be a mix of hard and penetrable, static, and moving (see Chapter 24).

21-07. **Lane Markers.** Markers, with lights for night firing, are set up if confusion could arise over the permitted arcs of fire. See also Pamphlet 21.

21-08. **Firing Areas.** On the lanes (bounds) hardening the area with a base course may be necessary to reduce the damage done by manoeuvring AFV. The area should be clearly marked and slightly raised to ensure proper drainage. The area may have to be marked.

21-09. **Arc Markers.** Arc Markers should only be erected when their use is essential to safety, such as when natural or constructed features cannot be clearly identified as marking the extremities of arc, or when the exercise is designed using points A - F as described in Pamphlet 21. Arc markers are to be constructed to ensure good visibility by both crew Safety Staff and RCO. They are to be painted in distinctive colours so that they are clearly visible. Arc markers are also to be constructed so that they can be clearly visible through thermal sights.

Live Firing Tactical Training

21-10. A Live Firing Tactical Training (LFTT) Range is a temporary facility set up on a LFTTA. The Target Operator under the direction of the RCO will control the movement of targetry.

Range Infrastructure

21-11. Behind the firing line or start line, a control room or tower which has sound insulation may be required. A troop shelter and Range Warden's store should have electricity and a water supply. Provision for vehicle movement and waiting areas also needs to be considered.

Communications

21-12. **External.** A means of summoning the emergency services, ideally a land laid telephone is to be available.

Maintenance

21-13. **Responsibilities.** Maintenance is the responsibility of the RAU. Responsibilities may be divided as follows:

- a. **Range Warden.** See DSA 03.OME Part 3 Volume 1 Part 2.
- b. Property Management.
 - (1) Grounds, including maintenance of hedges and trees to be kept trimmed so they do not obscure the RCO view from the tower to the vehicles as they move down the range.
 - (1) Fencing and sign posting (See Chapter 2).
 - (2) Structures, roads, and drainage including stability of slopes and erosion control.
 - (3) Water and electricity supplies.
 - (4) Periodic refurbishment of the range structure.
- c. **Equipment Management.** Repairing and servicing equipment installed by single Service contract.

21-14. **Frequency.** Proper maintenance is dependent upon good liaison between the Range Warden and the RAU, and on properly scheduled maintenance periods. A heavily used range may need one day's maintenance each week plus one- or two-days' maintenance by the Range Warden each month. Two closed periods of a week or so may be needed each year for building and earthworks repair; this work should be combined with the contract repair of equipment.

21-15. **Targets.** Damage to targets and target positions can be considerable. It is essential after firing to ensure that target mechanisms remain properly protected. Any damage that cannot be rectified in a timely manner that may affect the safety of the range should be recorded and relevant action taken.

21-16. **AFV Routes.** FMX and battle run routes need to be kept in a reasonable state of repair. Excessive pitching and rolling could cause MG fire to go outside the RDA.

All dimension in metres unless otherwise stated

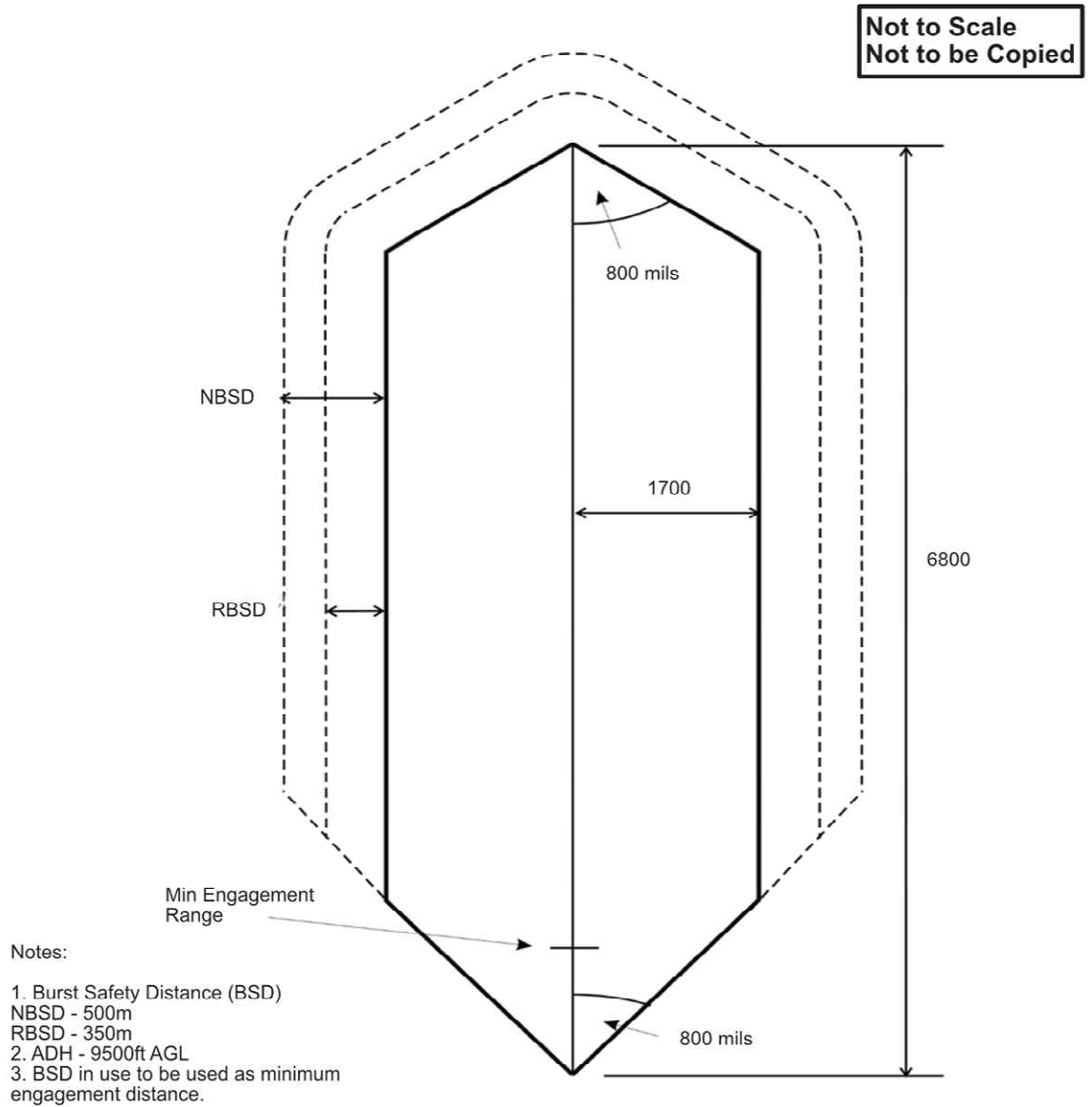
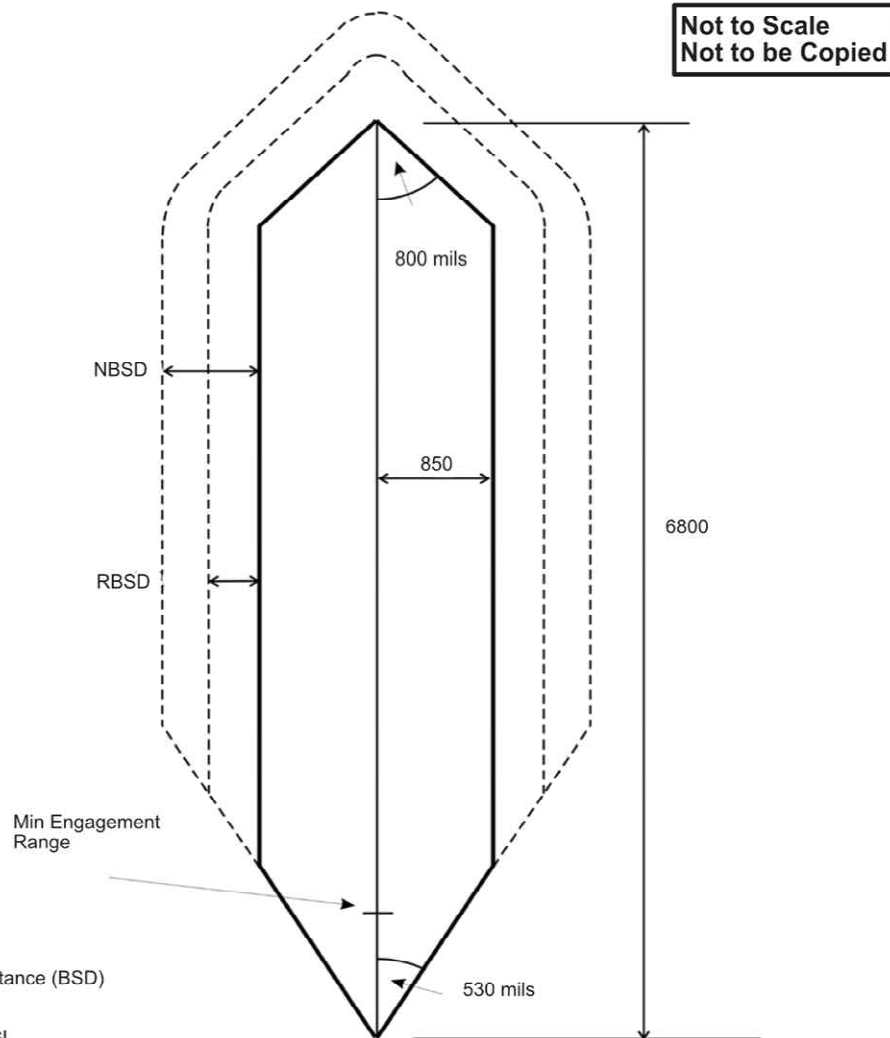

Fig 21 - 1. WDA Template, 30mm RARDEN HE L8 / L13 - Hard Target

All dimension in metres unless otherwise stated



Notes:

1. Burst Safety Distance (BSD)
NBSD - 500m
RBSD - 350m
2. ADH - 9500ft AGL
3. BSD in use to be used as minimum engagement distance.

Fig 21 - 2. WDA Template, 30mm RARDEN HE L8 / L13 - Soft Target

All dimension in metres unless otherwise stated

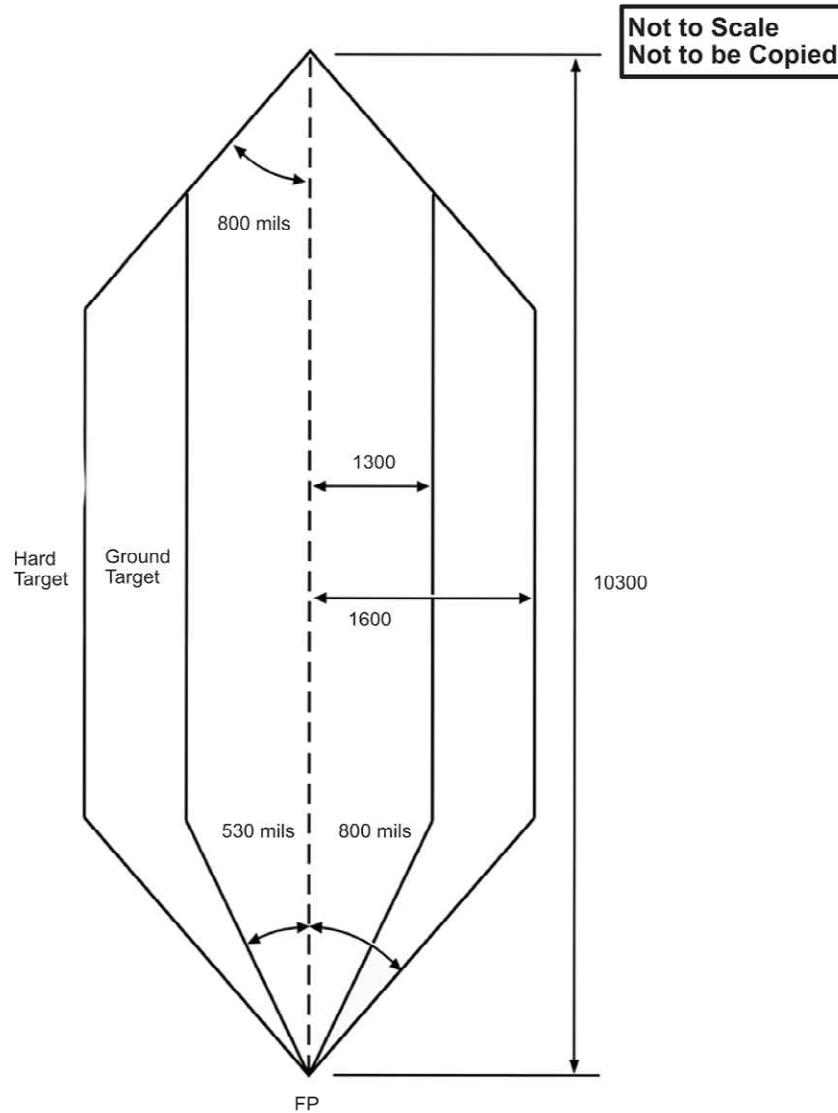

Notes:

1. ADH - 13000ft AGL
2. Although this round has no 'Burst Safety Distance' pieces of shot may be deflected up to 400m from the surface off the hard target.
Minimum range is 400m.

Fig 21 - 3. WDA Template, 30mm RARDEN Armour Piercing Discarding Sabot (APDS) Hard and Soft Targets

All dimension in metres unless otherwise stated

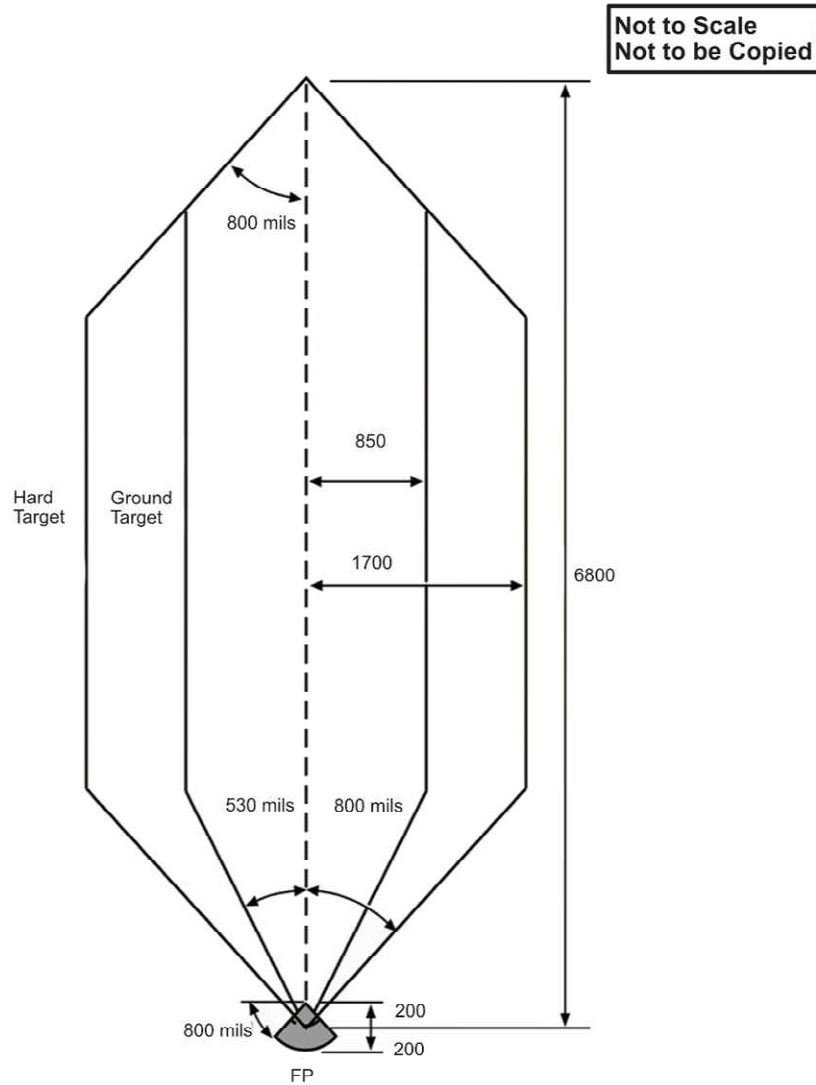

Notes:

1. ADH - 13000ft AGL
2. Although this round has no 'Burst Safety Distance' pieces of shot may be deflected up to 400m from the surface off the hard target.
3. Minimum range is 200m. When engaging at min range the wedge shape (shown shaded) at the firing point has to be clear of unprotected troops.

Fig 21 - 4. WDA Template, 30mm RARDEN Armour Piercing Secondary Effect (APSE) or Prac L12 Hard and Soft Targets

All dimension in metres unless otherwise stated

Not to Scale
Not to be Copied

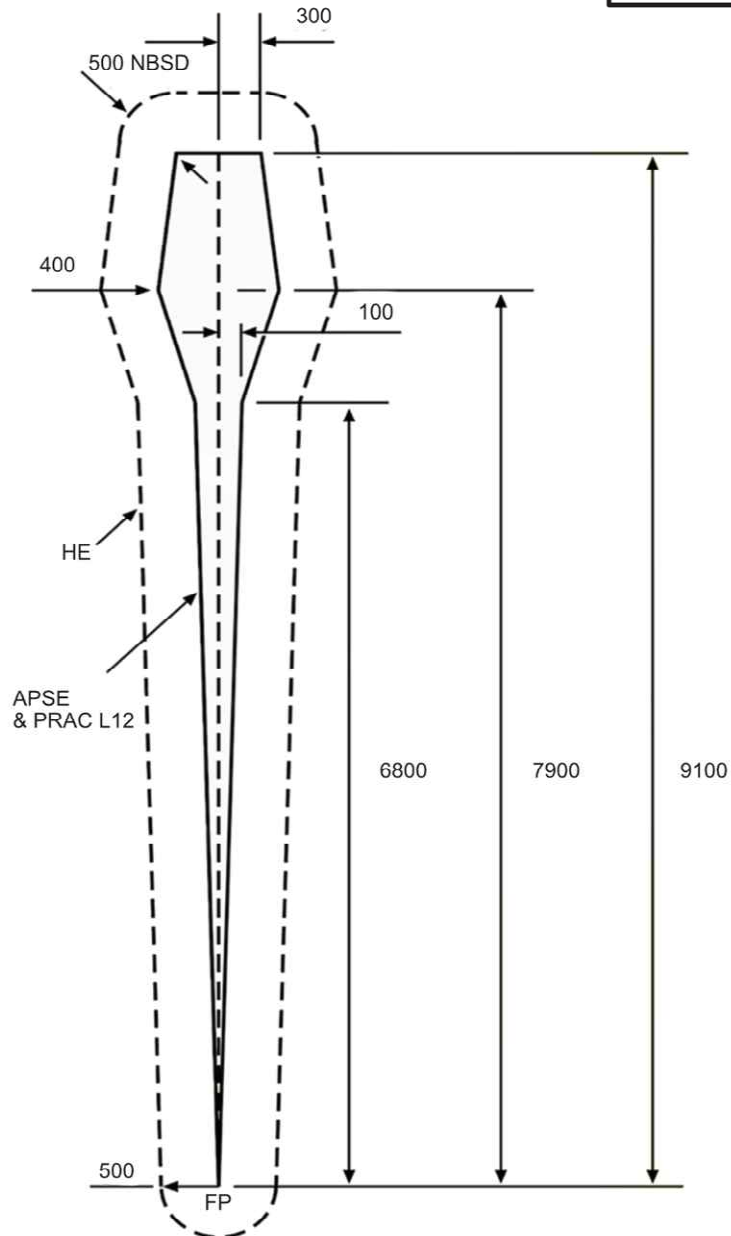

Notes:

1. ADH - 117200ft AGL
2. This WDA template is for single shot only.

Fig 21 - 5. HEF WDA Template, 30mm RARDEN HE L8 / L13 APSE or Prac L12

All dimension in metres unless otherwise stated

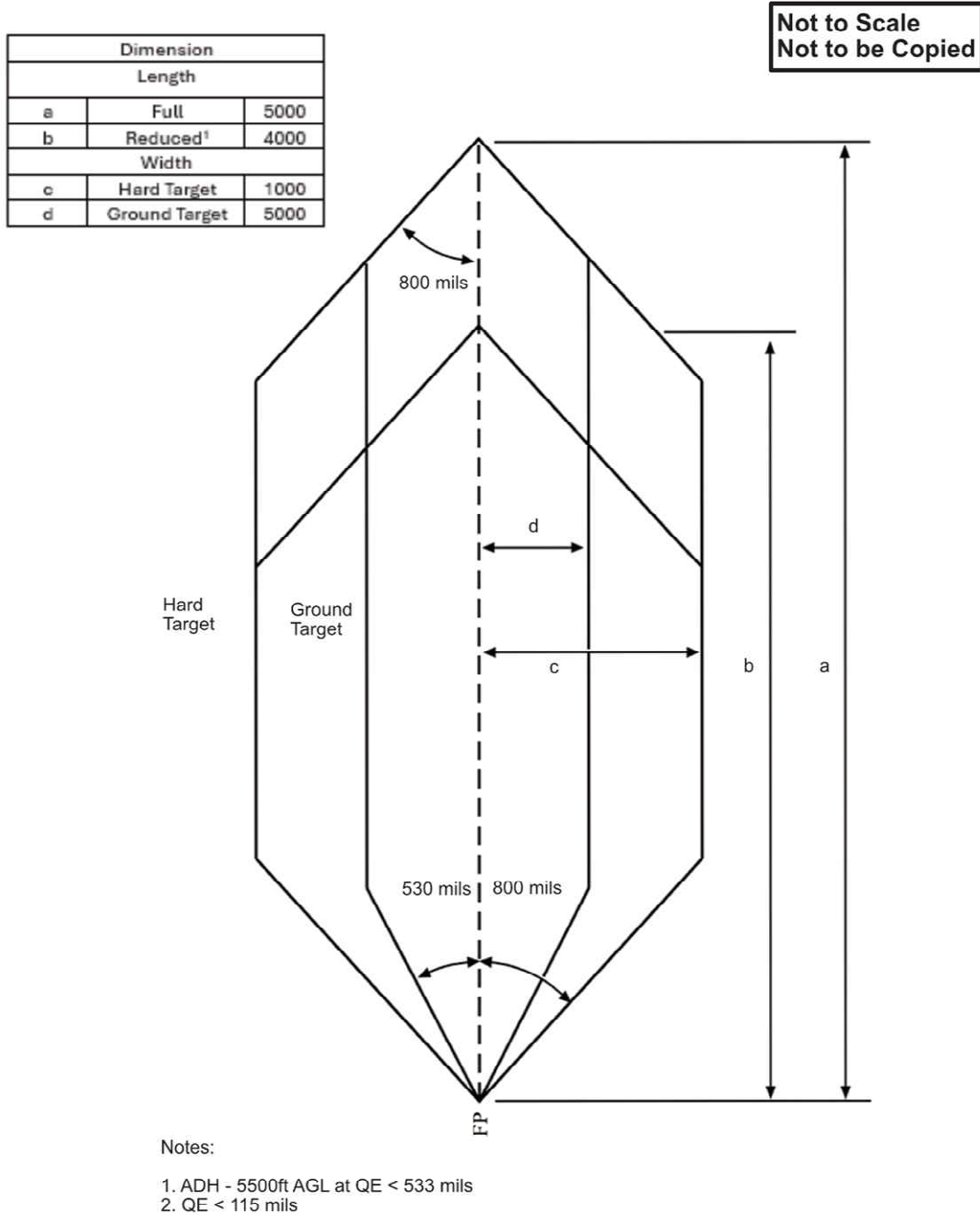

Fig 21 - 6. WDA Template, 30mm RARDEN – Discarding Sabot Reduced Range Round (DSRR) Practice (PRAC) Round L15A1, L15A2 & L15A3. Hard and Soft Targets

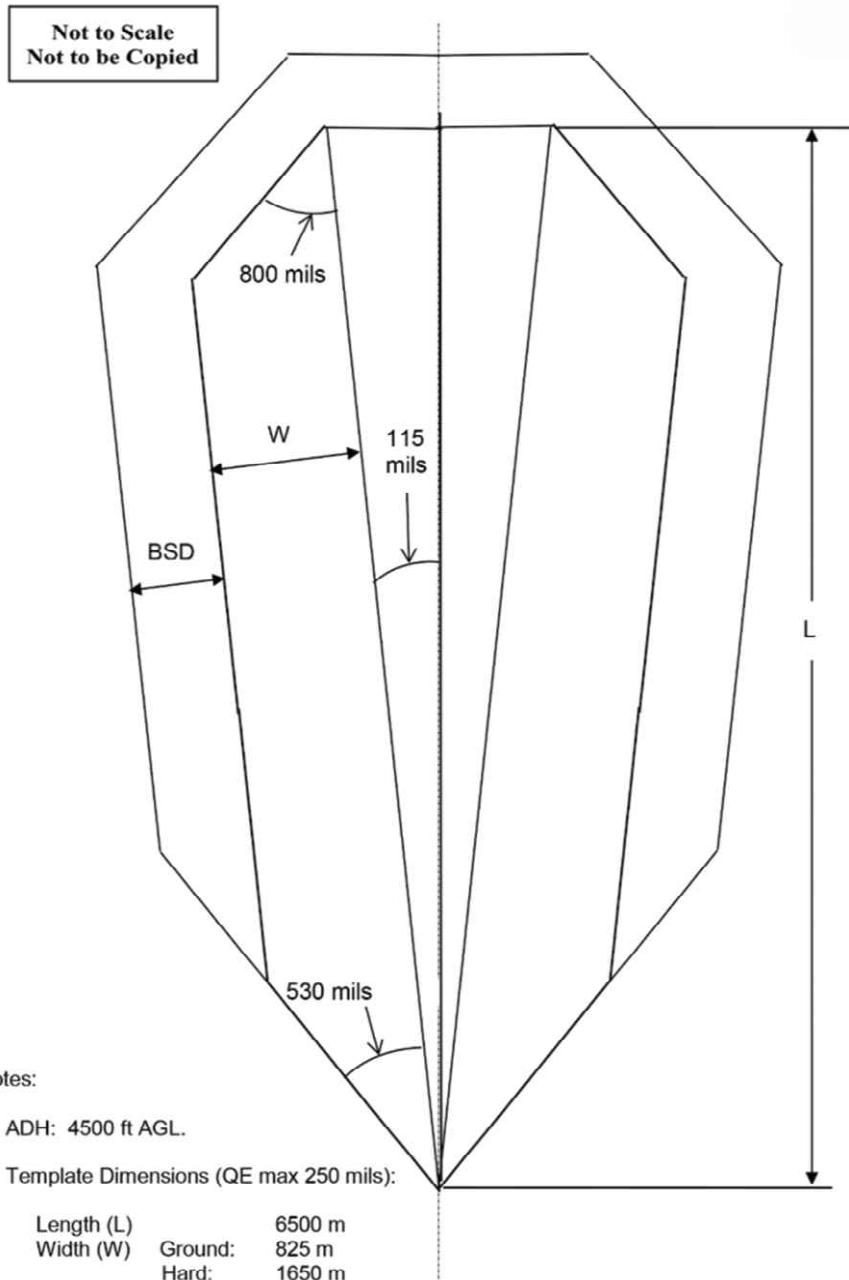
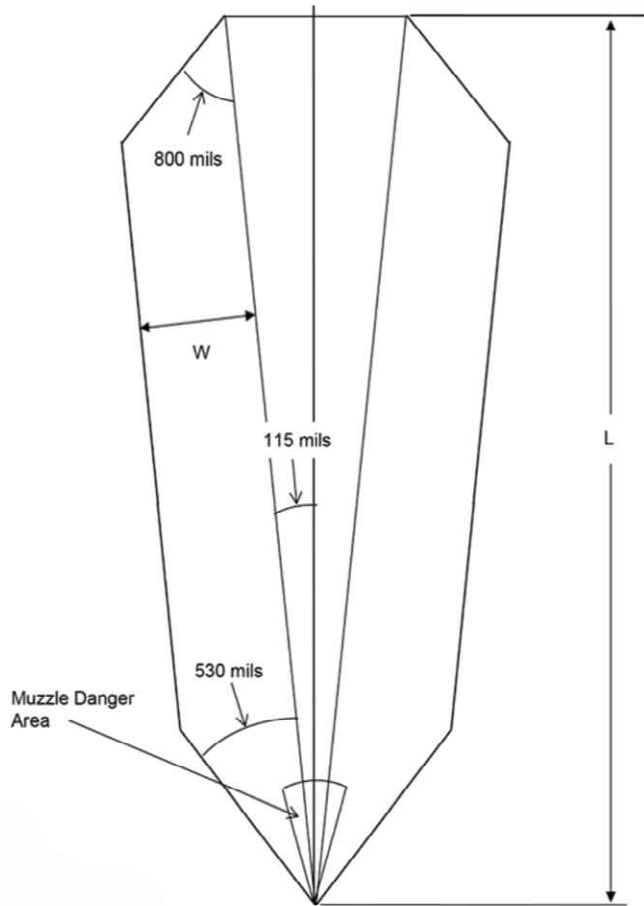

Fig 21 - 7. WDA Template for AJAX 40mm CT GPR-T/TP-T



**Not to Scale
Not to be Copied**

Notes:

1. ADH: 6000 ft AGL.
2. Template Dimensions:
See table
3. Minimum Engagement Distance:
600m – for hard target engagements.
4. Muzzle Danger Area:
Arc - 350 mils L&R
Distance – 300m

Ser	QE (Mils)	Range to Impact (m)	Fragment Distance (m)	Length (L) (m)	Width (W)	
					Hard (m)	Ground (m)
1.	≤40	9550	950	10500	2650	1350
2.	>40≤60	11800	950	12750	3200	1600
3.	>60≤80	13400	950	14350	3600	1800
4.	>80≤100	14600	950	15550	3900	1950
5.	>100≤120	15650	950	16600	4150	2100
6.	>120≤150	17000	950	17950	4500	2250

Fig 21 - 8. WDA Template for AJAX 40mm CT APFSDS-T

Chapter 22 - Air Rifle Ranges

Air rifles in this chapter are defined as weapons which fire a lead pellet using compressed air provided by either a spring-loaded piston or a compressed air reservoir and rated at not more than 12ft lbs (16.26J). This chapter describes the design and construction required for air rifles to be fired on existing and temporary ranges.

22-01. **Purpose.** Air rifles are not issued military SA and air rifle ranges are not scaled as a separate training facility. They are provided out of various funds, for Cadets, Youth Training Teams, and Display Teams.

Range Danger Areas

22-02. **Indoor Ranges.** The principal danger from air rifles is pellets bouncing back from striking a hard or backslash inducing surface, such as the rubber anti-splash curtain of a rimfire range.

22-03. **Outdoor Air Rifle Range-Layout and Danger Area.** The typical layout and RDA for a 6-lane outdoor Air Rifle Range established on a grassed area is shown at Fig 22 - 2.

Design

22-04. **Criteria.** Ranges on which air rifles are fired as part of authorised military training must conform to the requirements of this Chapter. The normal engagement distance for air rifles, indoors is 5.5m; outdoors the engagement distance is 10m. The target centre is used to determine the dimensions of any protective elements. If there is more than one target height, the outer points of aim are used. Targets should be mounted so that the target centre produces a depressed LoS.

Definition

22-05. The five types of Air Rifle Range are defined in DSA 03.OME Part 3 (Vol 1 Part 2) Chapter 5.

Existing Indoor Rimfire Ranges

22-06. **Backsplash.** Indoor Ranges used for air rifle shooting require an essential modification to ensure that the anti-splash curtain or the bullet catcher does not cause backslash. The anti-splash curtain provided for .22" ammunition must be covered with anti-splashback material, or a separate pellet stop set up in front of the anti-splash curtain. Air pellets are also known to bounce off softwood.

22-07. **Engagement distances.** Indoor ranges constructed to this chapter are suitable for engaging targets down to 5.5m. Outdoor ranges typically engage targets at 10m, refer to Fig 22 - 2.

22-08. **Bullet Catcher.** The existing angled plate and sand bullet catcher designs are safe for use. However, flat plate bullet catchers will cause pellet backslash and must be covered with a suitable anti splash back material that allows the pellet to pass through such as hessian sheet.

22-09. **Pellet Stop Materials.** Backslash may occur from the wide variety of pellet stop materials used behind pellet catchers. Softwood is particularly unreliable as an anti-

backsplash pellet stop. Ridged materials angled at 45° will deflect pellets down to the floor. If vertical rigid pellet stops or anti-splash curtains or similar curtains are used, they must be faced with a hessian or similar sheet suspended at least 50mm clear of the backing material. Pellets striking the hessian that is in direct contact with the backing material such as around the frame or bracing may produce backsplash. Where porous materials such as Hessian are used in an indoor range, they are to be removed from the range prior to any .22 firing taking place.

22-10. **Pellet Stop Size.** The minimum size for a pellet stop is calculated by adding a safety angle to the LoS horizontally on each flank and vertically. The safety angle is 80mils (4.5°) however air rifle ranges built before 1998 are permitted to continue to use its historic safety angle of 71mils (4°).

- a. **Height.** The pellet stop extends from the floor to a point at least 80mils above the highest LoS which is established in accordance with Chapter 2.
- b. **Width.** From each flank LoS an angle of 80mils projected from the firing point establishes the minimum width.

22-11. **Targetry.** Only penetrable or light fall-when-hit targets are to be used. Targets are to be mounted on softboard, light cellular plastics or on thin wires stretched across the pellet stop. Light pins or rubber bands are used to secure the targets as drawing pins with large heads are hazardous. Target retrieval systems require careful design so that no part of it within the pellet stop area causes backsplash. RITT can also advise on proprietary target systems that are available.

22-12. **Lighting.** Target lighting can be provided by fluorescent strip lights with a reflector behind. They may be set on the range floor with an angled baffle to deflect pellet strike or suspended above the bullet catcher height.

22-13. **Firing Positions.** Firers are to be spaced a minimum of 1.0m (C) apart. Where the pellet trap / target screen requires a specific posture height to achieve to level line of sight, the manufacturer's instructions are to be followed. Where a separate firing point for air rifle is placed on the range floor in front of the constructed .22 firing point the range floor in that area should be damp mopped before each use.

Indoor Ranges

22-14. **Construction.** When a purpose-built indoor air rifle or adapted rimfire range is not available, any room or building 7.5m or more in length may be used for an Air Indoor range. The fabric or cladding of all normal buildings will contain an air rifle pellet. It requires only the openings, such as down-range windows and vents, to be covered and all down-range doors to be bolted from the inside. Openings should be covered with:

- a. **Range Sides.** 5mm thick plywood, dense particle board or similar material.
- b. **Direct LoF.** 10mm thick, soft board or dense particle board or softwood / ply protected with loose hung hessian.

22-15. **Pellet Stop.** The pellet-stop the same as in paragraphs 22-10, 22-11 and 22-12.

22-16. **Clear Line of Sight.** Care is required to ensure that there are no obstructions, such as columns, partitions, or fixtures, near the LoS. A clear height of at least 600mm above

the LoS at the firing point and 250mm above the LoS at the target is essential. Sides must provide a minimum of 500mm clearance from each flank LoS.

Range in a Vehicle

22-17. **General.** A range mounted in the back of a vehicle is often required for displays and recruiting purposes. Firing is normally from the standing supported position with one to four firers leaning into the range protected structure.

22-18. **Construction.** With engagement distances as close as 5.5m anti-backsplash measures are important. Pellet catcher and pellet stop as described in paragraphs 22-10 & 22-11 are to be provided with the pellet stop covering the complete back wall. To stop pellets leaving the range, the sides and top of the structure are to be either 5mm thick plywood, dense chip, or particle board, or 1mm thick MS sheet. The height of the top or roof from the range floor is not to be less than 1m. A pellet-stop as described in paragraph 22-10 covers the complete back wall.

22-19. **Targetry and Lighting.** A target retrieval system operates below the range floor with a wire target holder running in a slot in the floor. Targets and target mounting are the same as stated in paragraph 22-11. If lights are required, they are recessed into the roof with an angled baffle to stop the edges causing bounce-back.

22-20. **Lighting.** Target lighting can be provided by fluorescent strip lights with a reflector behind. They may be set on the range floor with an angled baffle to deflect pellet strike or suspended above the bullet catcher height.

Tent Range

22-21. **Pellet Stop and Targetry.** The pellet stop may be constructed with straw bales or with the materials specified in paragraph 22-09. The dimensions are to be in accordance with paragraph 22-10 Targets and target mountings are the same as paragraph 22-11.

22-22. **Sides and Roof.** Consideration must be given to protecting the sides and roof of the tent against wild shots. Any ricochet inducing surfaces between the firing point and the target are to be protected.

22-23. **Firing Points.** The most suitable firing position is standing supported by a bench or table set at the appropriate height. A raised platform 450mm (T) high may be used for prone firing.

Open No Danger Area Ranges

Stop Butt Height.

a. **10m Range.** On an open 10m NDA range where the LoS in the standing position is either horizontal or depressed, a stop butt height of 2.3m is required to cater for:

- (1) A competition target centre height between 1200mm and 1600mm.
- (2) 800mm, the 80mils safety angle at 10m (see also paragraph 22-10).

b. **Ranges Greater than 10m.** Ranges more than 10m will require a higher wall to a maximum of 3m as at longer ranges the pellet trajectory falls off steeply.

22-24. **Stop Butt Width.** The stop butt must be wide enough to cover the intervals between firers and the 80mils safety angle from each flank LoS. At 10m the latter will be 800mm, which in practice should be increased to 1m to allow an extra measure of safety for the wind effect on pellets, and at increased ranges it will be greater.

22-25. **Firing Point.** To retain the depressed LoS from the prone and kneeling positions, a raised firing point 450mm (T) high should be constructed and the target centre height set between 300 and 600mm above the range floor.

Firing Outdoors

22-26. When firing outdoors without NDA structures the WDA template at Fig 22 -1 is to be applied.

Communications

22-27. A means of summoning the emergency services, ideally a land laid telephone is to be available.

Maintenance

22-28. As well as normal range maintenance requirements, air rifles create the additional tasks of:

- a. **Lead.** After each use pellets are to be removed and the range cleaned to prevent a build-up of lead contamination. Lead is to be disposed of in accordance with current instructions (see Chapter 25).
- b. **Pellet Stop.** The pellet stop requires careful inspection to ensure that it will not cause bounce-back.
- c. **Hygiene.** The firers, as they handle lead pellets, are to be instructed on the danger of lead poisoning and to observe strict hygiene in eating, drinking, and smoking. In addition, hand washing facilities are to be available.

22-29. **Air Rifle Range Responsibilities.** Maintenance is the responsibility of the RAU. Responsibilities may be divided as follows:

- a. RAU. See DSA 03.OME Part 3 Volume 1 Part 2.
- b. **Property Management.** General inspection with emphasis on the:
 - (1) Condition of the range structure.
 - (2) Stability of the back wall behind the pellet catcher.
 - (3) Warning signs and interlock safety systems (if fitted).
 - (4) Ensure there is no pellet damage to electrical or gas infrastructure.
- c. **Equipment Management.** Repairing and servicing equipment installed by single Service contract.

22-30. **Frequency.** Proper maintenance is dependent upon the RAU, and on properly scheduled maintenance periods.

22-31. **Pellet Catcher.** Regular inspection of the pellet catcher is required to ensure that it is in good repair. Pellet catchers may also need frequent emptying and frequent cleaning.

22-32. **Range Structure.** The range structure should be inspected regularly for damage from shot strike. Any strike is to be marked, and the cause investigated and recorded in a paper version of Range Log MOD Form 906.

Compliance Check

22-33. The following are to be checked:

- a. Authorised weapons, ammunition, and practices.
- b. Pellet catcher correctly sized and specified.
- c. Backsplash / ricochet hazards eliminated. Baffles (if any) correctly positioned detailed.
- d. Targets and firing points correctly sized and positioned.
- e. Target centre height and flank positions clearly identified.
- f. Adequate ventilation and lighting.
- g. Suitable and sufficient safety signs.
- h. Adequate access and egress.

Not to Scale

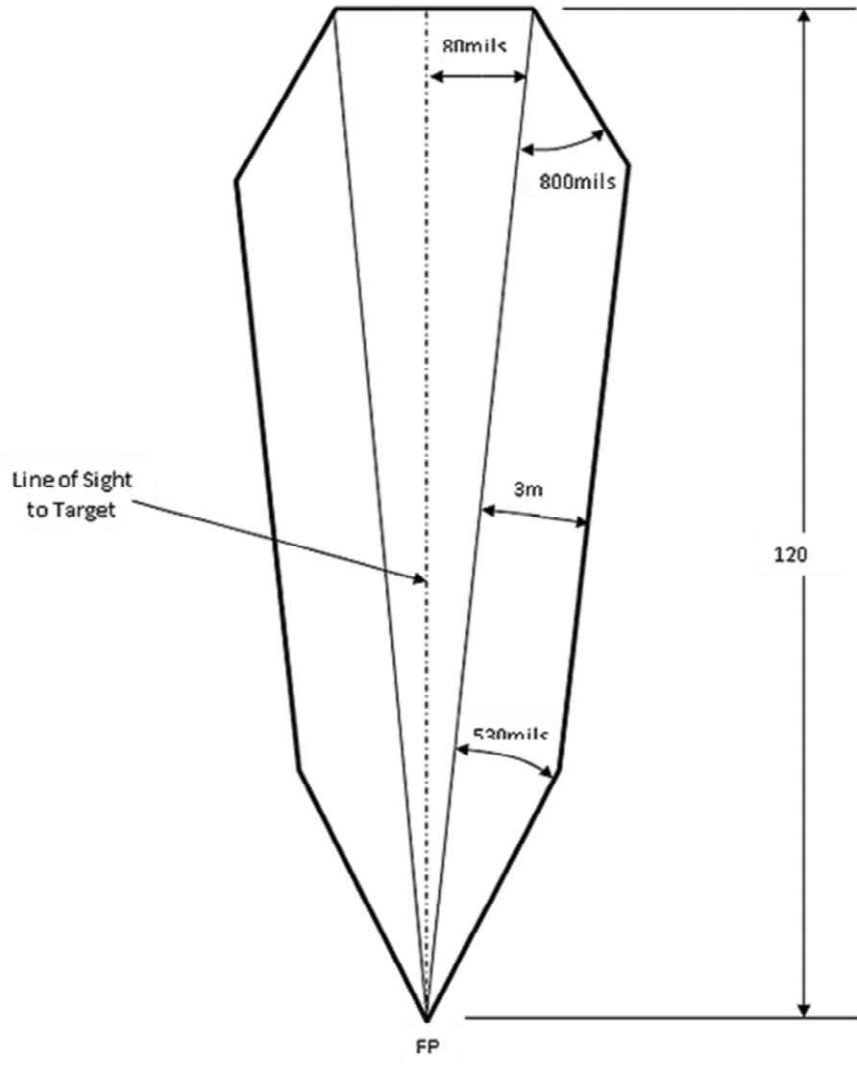

Fig 22 - 1. WDA Template, Air Rifle

The diagram shown here represents a 6-lane Air Rifle Range allowing 1m between firers. The dimensions are only applicable to ranges established on a grassed area.

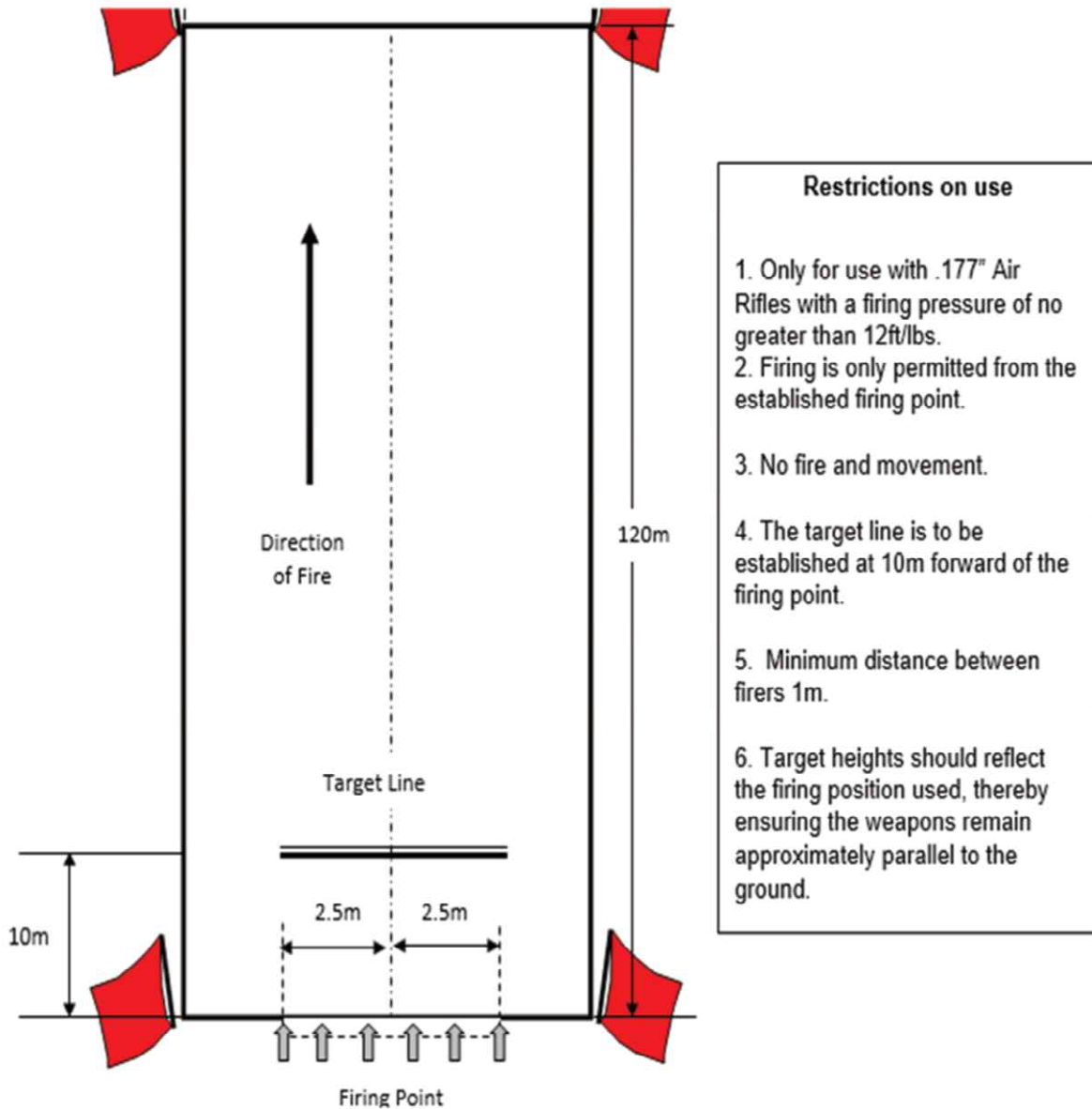

Fig 22 - 2. Air Rifle Range, Layout, Including Range Danger Area (RDA)

Chapter 23 - Weapon Launched Grenade Ranges

These are purpose-built ranges to permit controlled firing of 40mm Underslung Rifle Grenade (UGL) and Grenade Machine Gun (GMG). The aim of this chapter is to give the design and construction details for weapon launched grenade ranges.



Range Danger Area

23-01. **Underslung Grenade Launcher.** The Underslung Grenade Launcher (UGL) WDA for the 40mm Low Velocity High Explosive Dual Purpose (LV HEDP) is shown at Fig 23 - 1 and the WDA for 40mm LV Prac rounds is shown at Fig 23 - 2. For use of 40mm APERS (L75A1) the template shown at Fig 23 -1 is to be used.

23-02. **Grenade Machine Gun.** The ammunition for training includes Flash Bang Linked S429 fired into a controlled impact area, Target Practice Tracer S415A and Practice Impact Signature Marker both of which may be fired on any LFTTA. HE ammunitions should only be fired into a Closed Impact Area unless it can be guaranteed that any blinds can be safely located and disposed of. The WDA for the GMG HE is at Fig 23 - 5 and GMG Practice at Fig 23 - 6.

Siting

23-03. **Weapon Launched Grenades.** Ranges should be sited in reasonably clear areas where scrub and grass can be effectively managed. UGL and GMG ranges may be located on any designated training area or co-located with the Anti-Tank range to enable the WDA templates to be overlapped thus making most economic use of available land. Practice grenades may be fired on other standard ranges and training areas subject to the Range Standing Orders specifically allowing it. Consideration is to be given to any likely damage caused by the projectile and its 30m burst safety distance. The burst safety distance is required due to the fragmentation of the projectile on impact with hard surfaces. There is no HE content. The minimum range for engaging targets is 30m.

23-04. **Blinds.** The grenade is relatively small and therefore consideration must be given to locating blinds where there is the potential for a residual hazard. For UGL HEDP rounds a Closed Impact Area is normally required. Where the ground is such that the location and clearance of blinds may be guaranteed, which will be determined by a Site-Specific Risk Assessment and permitted in Range Standing Orders, a controlled impact area may be used. Subsequent references to the control of blinds in this chapter refer to use on a

controlled impact area and not closed impact areas. Attempts should be made to locate the range so that the target is engaged in a depression, thus minimizing the extent of exclusion fence required on closed impact areas. Minimum size of closed impact area for the UGL is 150m x 100m (see Fig 23 - 1). For details of impact areas see Chapter 2.

23-05. **Co-location with an Anti-Tank Range.** When co-located with NLAW the siting of the UGL / GMG target must be sited outside the NLAW 'clear zone'.

Construction

23-06. **Firing Point.** Where it is deemed necessary to provide a firing point, the design should enable standing and kneeling firing postures. It must also provide the firer and safety supervisor with sufficient protective cover from the effects of fragmentation and blast. The firing point is to comprise of the following elements (see Fig 23 - 2):

a. **Earth Bank.** Protective cover is to be provided by a castellated earth bank constructed as follows:

(1) **Dimensions.** The bank is to have a minimum thickness of 750mm (C) at the crest and provide a height of 1.2m (C) above the firing point floor surface. The overall width of the crest of the earth bank is to be divided as follows:

(a) A minimum 2m (C) wide section to provide sufficient protection to the safety supervisor and the firer adopting the standing posture.

(b) A 600mm (C) wide opening to permit the kneeling postures to be adopted.

(c) A minimum 1m (C) wide section to provide sufficient protection to the safety supervisor when the kneeling postures are adopted.

(d) The remainder of the earth bank beyond the dimensions stated, is to be sloped away at the natural angle of repose for the soil type used.

(2) **Materials.** The bank is to be formed using compacted earth fill, with 150mm (S) depth of topsoil to the surface. The topsoil is to be seeded to assist in retaining the correct thickness and profile of the protective cover.

b. **Retaining Structure.** The retaining structure is to be constructed so that the combined dead, imposed and live loads are sustained and transmitted to the ground safely.

c. **Floor Surface.** The floor surface of the firing point is to be constructed as follows:

(1) **Dimensions.** The overall width of the floor surface is to be the same as the bank crest with a depth of 2.45m (T).

(2) **Materials.** A typical firing point surface is 10mm (T) single sized rounded granite chippings to a thickness of 100mm (T), laid on a suitably compacted, free-draining base. Chippings to be surrounded by treated timber boards, set on edge, to assist in retaining the shingle within the firing point area.

23-07. **Targetry.** Targets for the GMG, which are typically hulks, are placed a minimum of 220m from the firing point. A target representing a bunker at a minimum distance of 150m for UGL HEDP is to be positioned within an impact area. The UGL target is to be of durable construction to ensure minimum maintenance while retaining a realistic appearance (see Fig 24 - 9). The target is to comprise the following elements:

- a. **Armour Plate.** To provide suitable durability and minimum maintenance, the target face is to be constructed as follows:
 - (1) **Dimensions.** 2m (T) wide, 1 m (T) high and 25mm (T) thick, positioned approximately perpendicular to the ground level and LoF.
 - (2) **Materials.** Rolled Homogenous Armour (RHA) steel plate with suitable supports to the rear of the armour plate to provide stability. The front face of the armour plate is usually painted to give the impression of a sandbag bunker.
- b. **Earth Bank.** If a bank is considered necessary, it should be constructed clear of the steel plate so that blinds may be dealt with safely. To minimize the risk of UGL HE grenades getting under the steel plate as blinds, the plate should be buried up to 150mm below the surface or the surface built up to achieve the same protection.

23-08. **UGL Target Area.** To minimize the problems of locating blinds, the area around the target may be prepared to ensure detonation, and so a prepared area, illustrated in Fig 23 - 4 should be sufficient. A prepared area is one where all soft earth, reed and tall grass has been removed. In peaty areas imported stone or gravel, used to provide an adequate initiation surface.

- a. **Open Impact Areas.** Where the UGL is to be fired into an Open Impact Area the prepared area is to be as per a standard Grenade range in terms of depth and aggregate type.
- b. **Closed Impact Areas.** Where the UGL is to be fired into a Closed Impact Area the prepared area should be like that of a standard Grenade range.

23-09. **Initiating Stop Butt.** On ranges where depressed LoS with ground behind the target cannot be achieved, initiating stop butts may be constructed to capture rounds that miss the target. The dimensions of the initiating stop butt should be determined by the assessment of the RCO's ability to observe potential blinds that may fall behind the initiating stop butt. Where the RCO has an elevated observation point, an initiating stop butt should be constructed to the point where the RCO retains visibility of the impact area. Where the RCO will not be able to see the fall of rounds behind the target the initiating stop butt should be substantial to capture all shots. Advice from RITT should be sought for all new range or change proposals.

Communications

23-10. A means of summoning the emergency services, ideally a land laid telephone is to be available.

Maintenance

23-11. **Responsibilities.** Maintenance is the responsibility of the RAU. Responsibilities may be divided as follows:

- a. **Range Warden** see DSA 03.OME Part 3 Volume 1 Part 2.
- b. **Property Management.**
 - (1) Grounds.
 - (2) Fencing and sign posting. (See Chapter 2).
 - (3) Structures, roads, and drainage including stability of slopes and erosion control.
 - (4) Water and electricity supplies.
 - (5) Periodic refurbishment of the range structure.
- c. **Equipment Management.** Repairing and servicing equipment installed by single service contract.

23-12. **Frequency.** Proper maintenance is dependent upon good liaison between the Range Warden and the RAU, and on properly scheduled maintenance periods. A heavily used range may need one day's maintenance each week plus one - or two days' maintenance by the Range Warden each month. Two closed periods of a week or so may be needed each year for building and earthworks repairs; this work should be combined with the contract repair of equipment.

All dimension in metres unless otherwise stated

Not to Scale
Not to be Copied

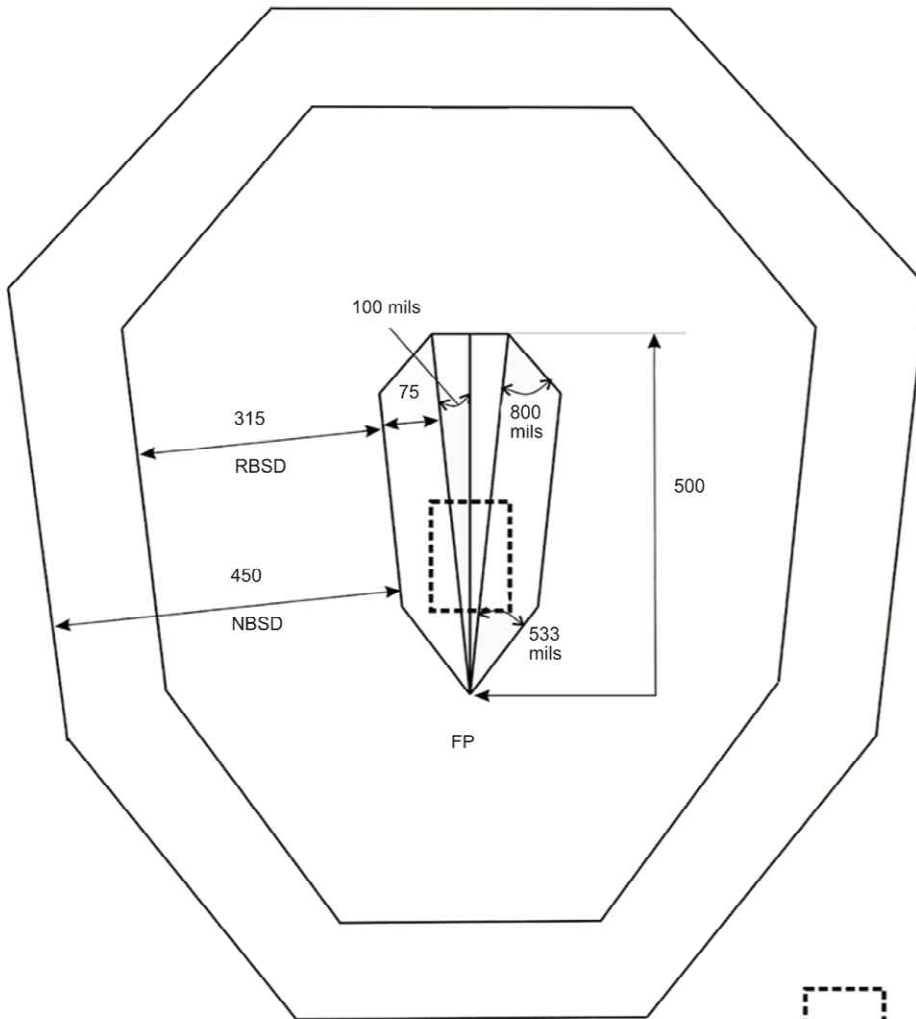

Notes:

1. ADH 1500ft AGL
2. Grenade arms between 11-19m from muzzle.
3. As the FP will be inside the BSD a protected FP must be used.
4. All personnel involved in the firing must be behind protection when the grenade functions.
5. Closest target engagement is 150m.



Min closed impact
are 150 x 100m box centered
around target

Fig 23 - 1. WDA Template for SA80 40mm Underslung Grenade Launcher (UGL) LV HEDP

All dimension in metres unless otherwise stated

Not to Scale
Not to be Copied

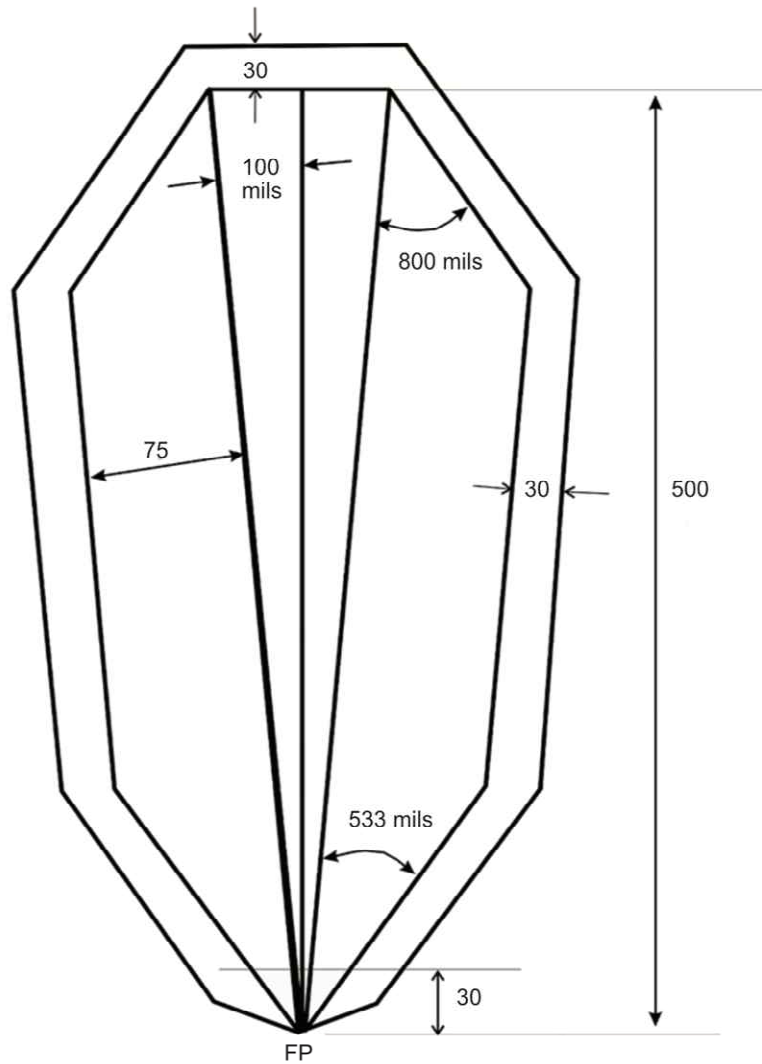

Notes:

1. ADH 1500ft AGL
2. Burst Safety Distance is 30m.
3. Closest target engagement is 30m.

Fig 23 - 2. WDA Template for SA80 40mm Underslung Grenade Launcher (UGL) L8A1 Practice Grenade

All dimensions in metres unless otherwise stated

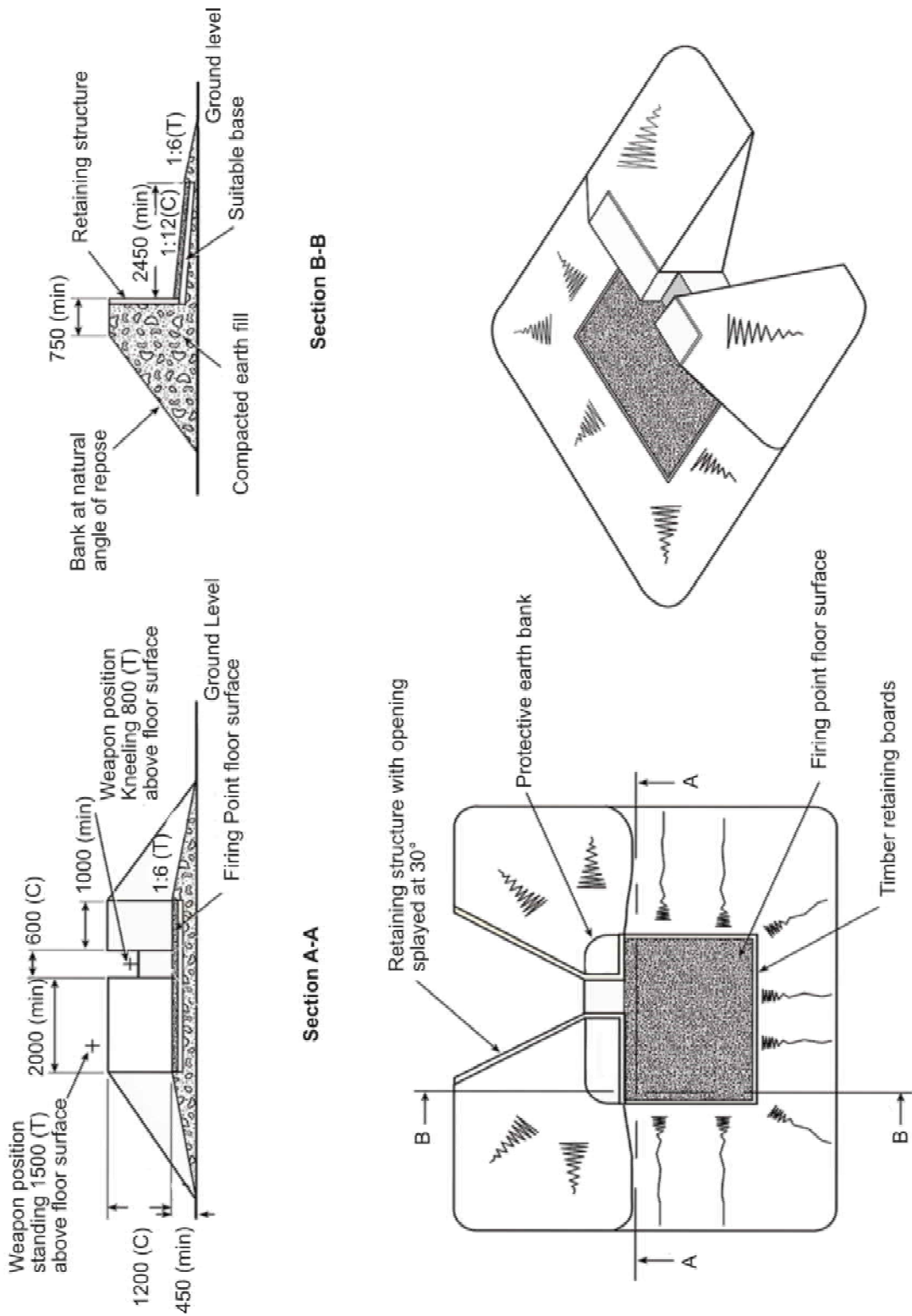

Fig 23 - 3. Firing Point Layout

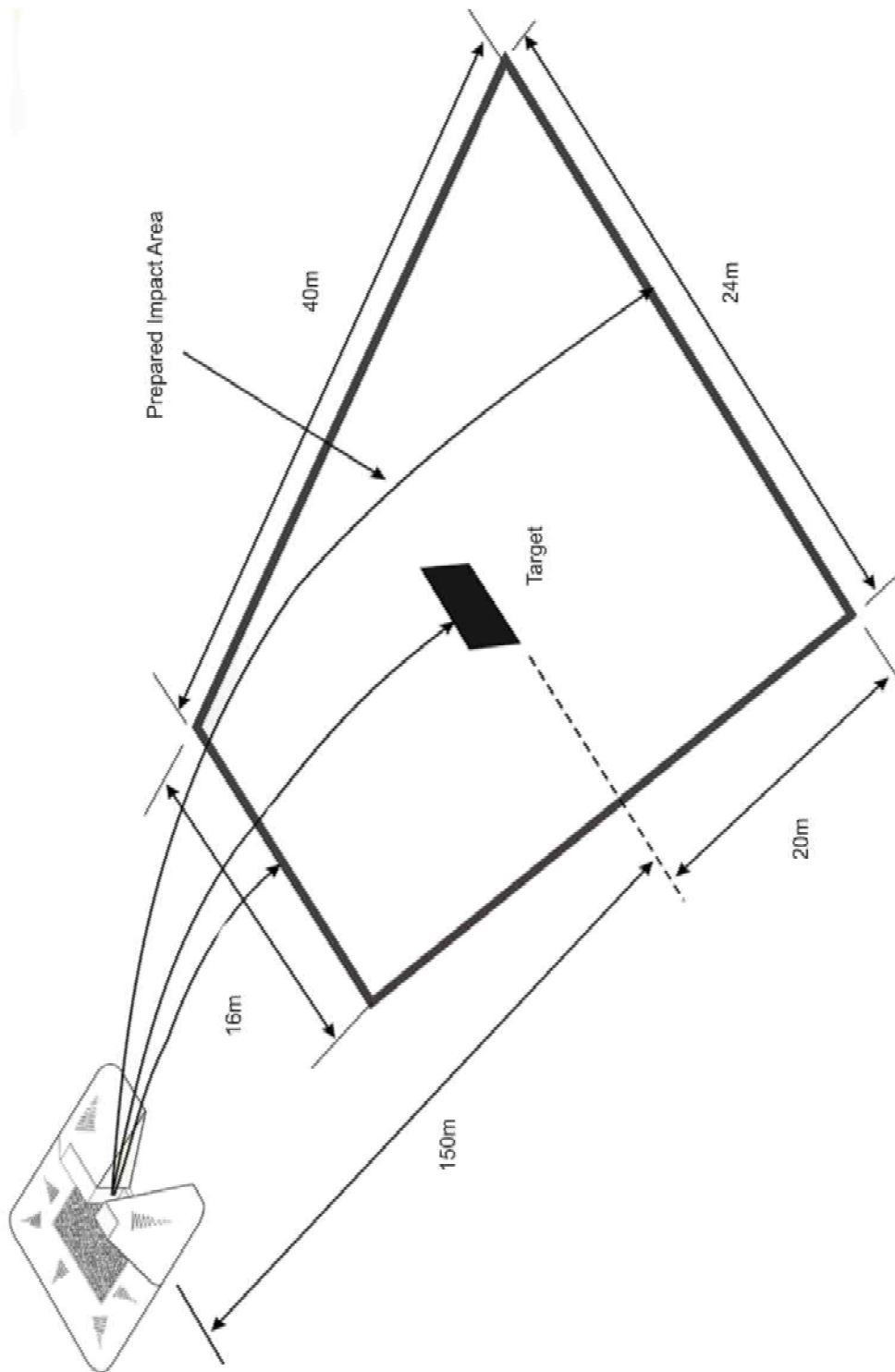
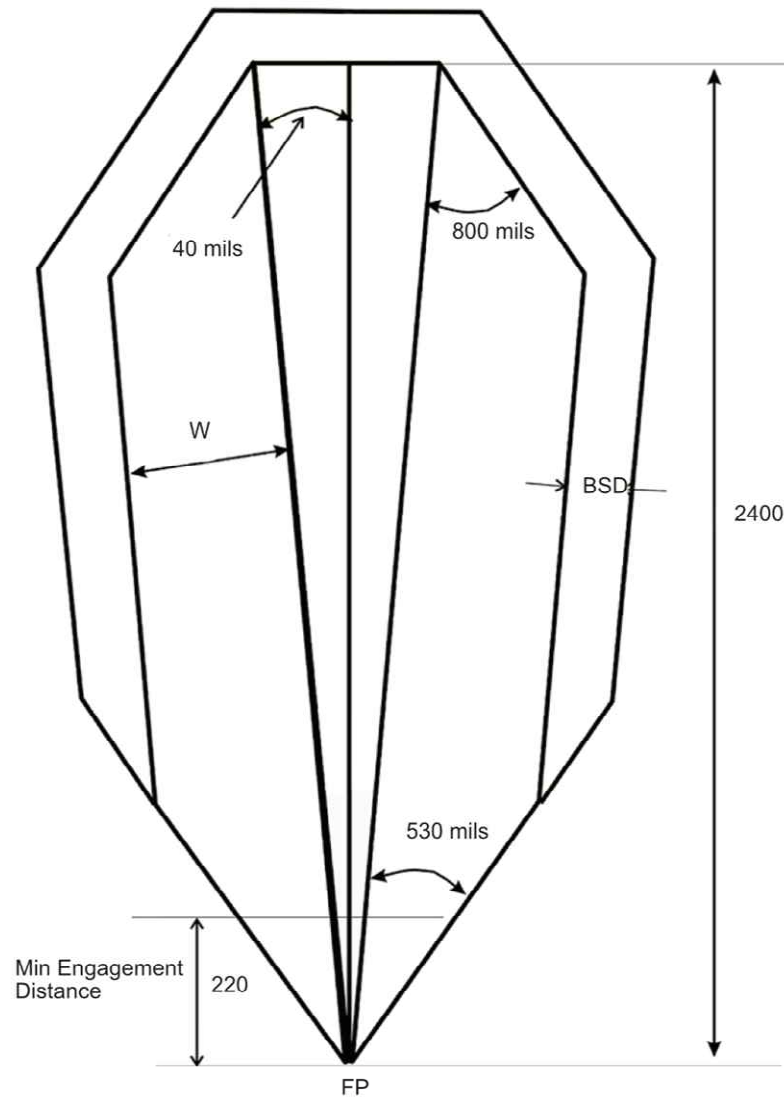

Fig 23 - 4. Prepared Impact Area

All dimensions in metres unless otherwise stated

**Not to Scale
Not to be Copied**



Notes:

1. ADH 3000ft AGL.
2. Burst Safety Distance:
Normal 310m
Reduced 220m
3. Ricochet width (W)
Ground targets 300m
Hard targets 600m
4. Minimum engagement distance is 220m.
5. This WDA has a QE restriction of 650 mils.

Fig 23 - 5. WDA Template for GMG 40mm High Velocity Grenade L134A1

All dimensions in metres unless otherwise stated

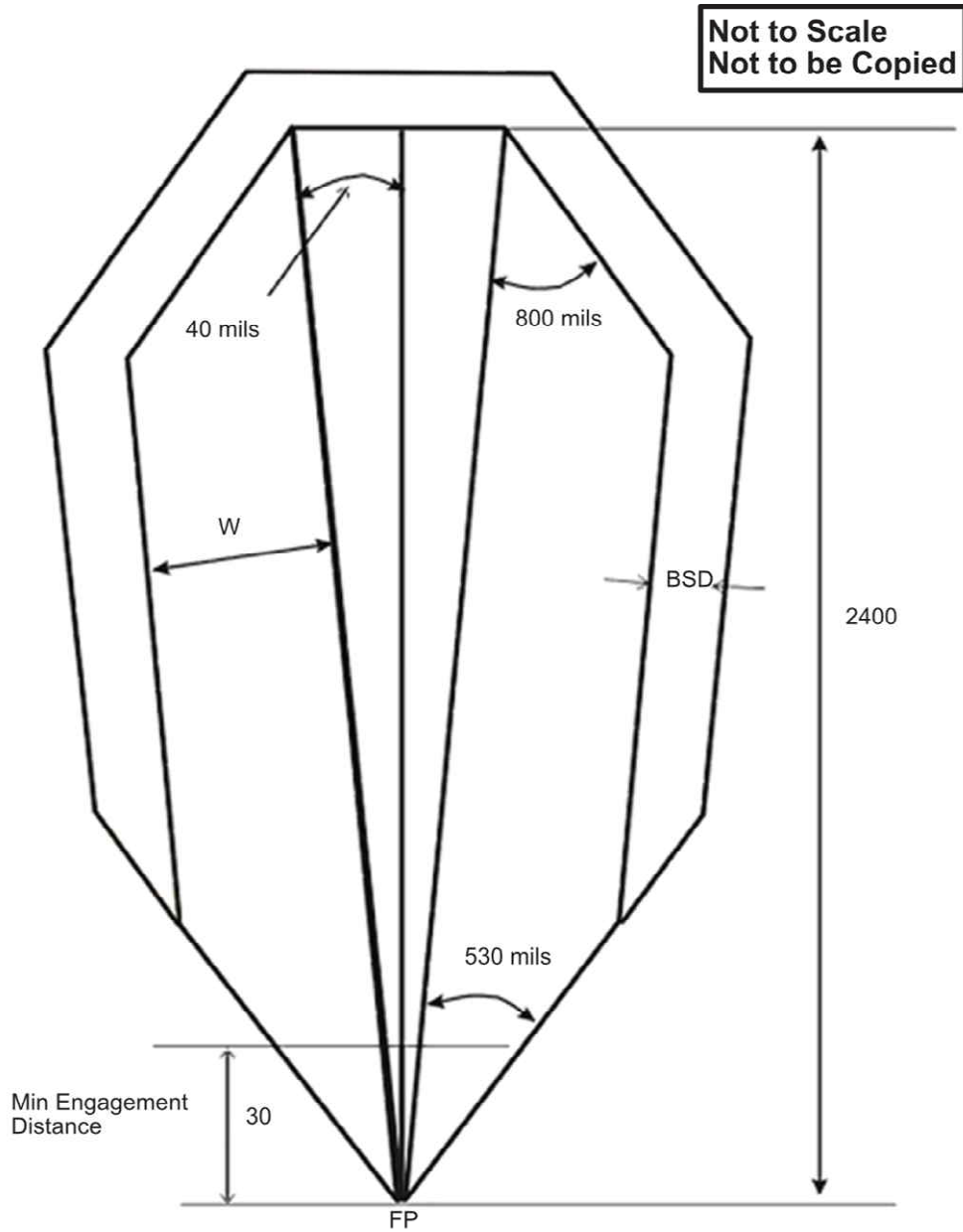

Notes:

1. ADH 3000ft AGL.
2. Burst Safety Distance is 30m
3. Ricochet width (W)
Ground targets 300m
Hard targets 600m
4. Minimum engagement distance is 30m.
5. This WDA has a QE restriction of 650 mils.

Fig 23 - 6. WDA Template for GMG 40mm High Velocity L134A1 Practice Grenades

Chapter 24 – Targetry

This chapter covers the provision, description, and maintenance of targetry approved by the Sponsor for use on the ranges described in previous chapters of this DCOP.



24-01. **Definitions.** Targetry is the supplied, non-constructed, part of a range and includes:

- a. **Target System.** A mix of Target Mechanism, static and moving, with associated Support Systems all controlled from a single source.
- b. **Targets.** Consumable materials struck by shot. They include pre-formed targets and the basic materials for making up targets.
- c. **Target Mechanisms.** Electrical, mechanical, pneumatic, and manually operated devices that expose targets on command operated by hand, by radio when portability is required, or by land line on fixed range installations. Target Mechanisms may expose single or multiple targets, with or without the ability to move.
- d. **Support Systems.** Ancillary systems, providing distraction, realism, and feedback in support of Target Mechanisms or Target Systems. Examples include Automatic Marker System (AMS), Enemy Fire Simulators (EFS), Visual Hit Indicators (VHI) and Smoke Generators
- e. **Infantry Target Systems.** Target Systems, Target Mechanisms, Support Systems and Targetry primarily designed for deployment on small arms ranges.
- f. **Armoured Fighting Vehicle Target System (AFV).** Target Systems, Target Mechanisms, Support Systems and Targetry primarily designed for deployment on ranges used by AFV.

24-02. **Design Criteria.** The use of the approved Targetry listed in this Chapter is essential to the safety of a fixed range as the type, position and size of Targets exposed is a principal consideration of a range's design. LoS, QE and ricochet determine range geometry, which may be adversely affected if unapproved Targetry is used.

Provision

24-03. **Sponsor.** Sponsorship and funding of Targetry systems for SA and IWS used on military land ranges for all the Services, including Reserves and Cadets, is the responsibility of Head of Capability (Ground Manoeuvre) (HOC(GM)), under the Deputy

Chief of the Defence staff (Capability) (DCDS[CAP]). The sponsor also approves indoor range Targetry and the construction of specialist buildings to house Targetry.

24-04. Target Mechanisms and Support Systems. Training and Simulation Systems Programme (TSSP) of Defence Equipment and Support (DE&S) procures and funds on the authority of the Sponsor:

- a. Target Mechanisms and Support Systems, including when appropriate, their installation and the training of operator and maintenance staff.
- b. Spares and spare parts for new Target Mechanisms and support to those systems on their introduction into service. Thereafter it is the responsibility of the Defence Infrastructure Organisation (DIO) Training Estates - through DIO Strategic Support contract.
- c. The RAU is responsible for providing and funding both outdoor and indoor range Targets and any specialist buildings to store Target Systems, Target Mechanism, Support Systems Targets and approving them for Service use.

24-05. Redeployment, Repair and Maintenance. HQ DIO is responsible for re-deploying, funding, and providing the repair and maintenance of approved in-service Target Mechanisms and Support Systems.

24-06. Targets. Consumable materials (Targets) will be procured by DE&S, Operational Infrastructure (OI). The procedure for demanding materials is:

- a. **Material Codified.** Basic non-codified (Not in Record – NIR) construction material can be supplied by OI by following the NIR process.
- b. **Material Not Codified.** Non-codified material can be procured provided funding is found by the demanding unit.

24-07. Targets are listed in The [Catalogue of Targetry Consumables](#).

Infantry Target Systems

24-08. Small Arms Range Targetry System. SARTS is a self-contained Infantry Target System which has replaced many legacy Target Mechanisms and Support Systems previously installed LFMT ranges. SARTS consists of the following:

- a. SARTS Static Target Mechanisms.
- b. Fixed Target Mechanisms (FTM) are installed on ETR / CGR ranges and are operated via a Range Control System (RCS) located in a control building. FTM's require to be ballistically protected and sited in a properly drained housing providing protection against rodents and vandalism. A power supply and signalling cable are also required.
- c. Field Firing Target Mechanisms (FFTM) are individually deployed as required on LFTTA's and are a self-contained battery powered target presentation device each operated by radio signal from hand-held electronic devices. FFTM's require to be ballistically protected.
- d. SARTS Moving Target Mechanisms.

e. **Fixed Template Moving Target (FTMT).** Are installed on Mechanised Moving Target Trainer Ranges (MMTTR) in a four or six lane configuration. Trolleys are mounted on metal rails traversing the width of each lane, a modified SARTS FFTM is fitted to each trolley. The FFTM modification allows either of the two faces of a target to be exposed to the firer.

f. **Field Firing Moving Target (FFMT).** These SARTS movers are fitted on most Individual Battle Shooting Ranges (IBSR) but may also be deployed on LFFTA. FFTM are a self-contained battery powered mover that traverse on metal rails. Metal rails can be configured to any length to meet the requirement. A FFTM is mounted on the FFMT which exposes the target. The FFMT may be configured to trickle charge its on-board batteries where a ranges electrical infrastructure allows.

24-09. **Electric Swivel Targets.** Electrically operated devices which replaced hand operated turning devices. Banks of two or three targets per lane are fully exposed by turning through 90° (1600 mils) using a hand-held controller, which is generally connected by an electric cable. The devices are ballistically protected although not strictly portable, the mechanisms can be moved to and from a targetry store.

24-10. **Portable Radio-Operated Targets.** There a small number of legacy, self-contained battery powered Target Mechanisms in service, provided by various manufacturers which are primarily used on field firing ranges. The majority are controlled over radio links from hand-held controllers. These portable Target Mechanisms are limited to exposing a target, recording the number of hits on a Target, and initiating associated Support Systems such retaliatory devices. These Target Mechanisms must be ballistically protected.

24-11. **Small Arms Pop Up Targetry System (SAPU).** SAPU is a self-contained Infantry Target System which predates the SARTS Infantry Target System. The SAPU System comprises of Small Arms Pop-up (SAPU), Small Arms Mover (SAM) and Support Systems (EFS).

24-12. Spare SAPU Systems are held by the Support and Repair contractor at Netheravon Down, near Netheravon in Wiltshire to support military Overseas exercises and deployments.

24-13. **SAPU Static Target Mechanisms.** A self-contained battery powered Target Mechanism primarily used on field firing ranges. Manually controlled over radio links from hand-held controllers. A pre-determined scenario of exposures may be uploaded to the hand-held controller drafted initially on a computer. SAPU are limited to exposing a target, recording the number of hits on a Target, and initiating associated Support Systems (EFS). The SAPU Target Mechanisms must be ballistically protected.

24-14. **SAPU Small Arms Mover (SAPU SAM).** Deployed on LFFTA SAPU SAM are a self-contained battery powered mover that traverses on metal rails. Metal rails can be configured to any length to meet the requirement. SAPU SAM may be configured to trickle charge its on-board batteries where a range's electrical infrastructure allows.

24-15. **Mechanised Moving Target Trainer (MMTT).** This system has up to six trolleys which are towed on a straight rail track by an electric winch at four selected speeds between 0.8 and 4.0m/s. Targets are erected on trolleys which traverse a 10m rail across the lane, starting and finishing behind cover. The equipment is intended for permanent installation and forms the basis of the MMTTR unless already upgraded to receive SARTS.

Armoured Fighting Vehicles (AFV) Target Systems

24-16. **General.** There are three categories of Atk targets:

- a. Static hard.
- b. Static soft.
- c. Moving soft.

24-17. **Static Hard Targets.** A variety of equipment and construction can be used such as:

- a. AFV hulks, the target of choice; use can be prolonged by filling with compacted soil or lean mix concrete.
- b. Heavy steel plating, preferably armoured; scrap plating from warships has been used.
- c. Solid concrete constructions, whether reinforced or not, set into the ground.
- d. Integrated construction of built-up dry bonded units to simplify replacing damaged sections.
- e. Interlocking steel plating supported on a framework.
- f. Light man-manageable steel plating clipped or slotted together to ease changing individual plates as shown in Figs 24 - 1 and 24 - 2.

24-18. Materials other than steel break down leaving a rubble which must be regularly removed.

24-19. **Stop Butts.** Stop butts may be provided to initiate rounds which miss the target or pass through holes in it. Careful planning and siting will considerably reduce the number of blinds.

24-20. **Static Soft.** Targets of light penetrable material, such as a light timber frame with infills of mesh, hessian, plywood etc, in the shape of a vehicle or an AFV may be used for practice inert munitions. To initiate a flash head indicator, targets of a light steel construction, typically 2.5mm thick mild steel, will be required. Heating elements may be included to provide an IR / Thermal signature.

24-21. **Moving Soft.** Moving soft targets are constructed the same as static targets described in paragraph 24-20. Systems used to move them include:

- a. Winched or towed sledges.
- b. Engine or electric motor-powered trolleys on rails.
- c. Winched or towed floats on an inland waterway or sea.
- d. Gravity run on a prepared ramp or slope.

24-22. **Requirements.** The system should provide:

- a. A constant target speeds.

- b. A speed range between 5 and 40 kilometres per hour (kph) with intermediate speeds of approximately 12, 20 and 30 kph.
- c. Target runs as direct crossing and oblique crossing. Head-on targets, both advancing and retreating, are mounted on sledges drawn by winch.

24-23. **In-Service Examples:** Hima Sella (Theissen) System. Targets, which can be either sledge or rail mounted, are pulled by a winch at speeds up to 60kph. The system requires careful siting and installation and is also considered to be portable.

24-24. **Target and other Rail Systems.**

a. **Wickham Trolley.** This rail mounted system can take heavy targets. Each trolley has an engine and runs in a loop being stopped by a trip in the track. The track can be laid to present the target at a variety of angles and speeds. It is a very reliable and solid system when the track is properly laid but changing the layout is difficult.

b. **Multi Path Railway System (MPRS).** The MPRS at Lulworth is a unique target railway system based on a tube train system. Maintenance and operation are provided by the DIO Industry partner and governed by the rules set out in JSP 790. The following rules apply:

- (1) [JSP 790 - MOD Rail Safety Management Policy](#) sets out the policy, key responsibilities, requirements, procedures, and principles for the safety management of all MOD railway activity.
- (2) For this DCOP, MOD Rail Safety Management Policy, JSP 790 applies to:
- (3) All personnel who are required to operate or work on MOD railway equipment and infrastructure (Including Permanent Way (PW) activity).
- (4) All personnel who are involved in Target railway systems acquisition.
- (5) All MOD rail activities have the potential to endanger the health and safety of MOD personnel, the public and / or environment during normal operation, trials, training.
- (6) Railway activities and / or operations pertaining to this DCOP are identified as:
 - (a) Equipment Management.
 - (b) Target Railways.
 - (c) Safety compliance, maintenance, and disposal of MOD rail sites.
 - (d) Tenants undertaking work on MOD estate and / or railway infrastructure and equipment.
 - (e) PW maintenance and construction.
 - (f) MOD rail activities at third party sidings / locations.

(g) Rail mounted testing facilities used as part of the UK and NATO European Regional Test Centre (ERTC) for the accreditation of small arms and cannons.

c. **Equipment Protection.** If the natural shape of the ground cannot be used, mantlets will be required to prevent trolleys, track ways, cables and pulley points being damaged by firing. If track ways are excavated, the soil arising may be used to form the mantlets.

d. **Infrastructure.** On permanent installations a shed may be required at the end of the run to accommodate engines or winches and the target on its mover. Access roads, troop shelters, car parks and other ancillary installations are also likely to be required.

Targets and Accessories

24-25. **Figure Targets.** Fig 11, 12, 14 and 20 targets are the basic range for military training, and these are illustrated in Fig 24 - 3. Fig 11 and 12 targets are also available in reduced sizes to represent the full target viewed from a greater distance. Targets Fig 21, 22, 26, 27 and 28 used to train personnel in Close Quarter Marksmanship are shown at Fig 24 - 6¹. Other targets suitable for cadets are shown in Fig 24 - 5. Targets are issued in a variety of forms for applications. These include:

a. **Colour.** Two colour variations are available: black and ochre and black and silver. The target type selected should provide the firer with the best opportunity to acquire the target with consideration made to range seasonal variations and the tactical exercise to be conducted.

b. **Materials.** Plywood veneers with a printed paper facing for static (stick-in) use or fitting in GR Hythe frames and aluminium or plastic with a pre-printed facing for fall-when-hit mechanisms.

c. **Scoring Circles.** Scoring circles are provided on targets for basic practices and for Army Rifle Association (ARA) competition shooting. They are not provided on fall-when-hit targets.

d. **Optical / Iron Sights.** ARA target designs are varied to suit the type of sight being used.

e. **Other Practices.** Targets are adapted to suit a variety of practices and training requirements such as grouping and zeroing, and multiple Fig 11 for GPMG.

24-26. **1.22 m² and 1.83 m² Screen Targets.** A 1.22m² (4 ft²) timber frame is covered with hessian and faced with ochre coloured paper to form a screen. A Fig 11 or 12 targets facing is pasted in the centre as an aiming mark. The range of ARA targets is shown in Figs 24 - 6 and 24 - 7. Appropriate screen targets are also used for Stage 1 and 2 shooting and for cadet, National Rifle Association (NRA) and ARA competitions. 1.83m² (6 ft) screens may be held for NRA and ARA shooting at distances over 400m, for which Table 24-1 gives the scoring circle diameters that are marked with wax crayon.

¹ These target illustrations are preproduction sketches and do not represent the final in service version

Table 24-1 - NRA and ARA Scoring Circle Diameters

(a) Ser	(b) Figure Target Type	(c) Figure 12 A 500 m (mm)	(d) Figure 12 B 300 m (mm)	(e) Figure 12 C 200 m (mm)	(f) Figure 12 D -	(g) Figure 11 or 12 Stages 1 & 2 shooting
1	Series A (optic sight)	300 600 1200	180 360 750	120 240 750 1200	300 1200	760 1200
2	Series B (iron sight)	375 750 1200	225 450 750	150 300 750 1200	300 1200	760 1200

24-27. **Head-On Tank Target.** A 1.22m² frame is faced in ochre with a black head-on tank silhouette (see Fig 24 - 8).

24-28. **Representative Sizes.** Targets may be scaled to represent proportions presented at a notional distance, rather than the true engagement distance. Proportions may be calculated by applying the formula:

$$\text{Representative dimension} = \text{Actual Target Dimension} \times (\text{True Distance} / \text{Representative Distance})$$

Example: An Atk weapon is to be used at a true engagement distance of 100m whereas the practice requires a representative range of 450m. If the actual width of the tank target being engaged is 3.5m, the representative width will be:

$$3.5\text{m} \times (100\text{m} / 450\text{m}) = 0.778\text{m} \text{ or } 778\text{mm}$$

24-29. **Falling Plates.** These are made of 8mm thick armour plate, approximately 300mm square and painted white. They are free standing on a narrow flange as shown in Fig 24 - 8, and their positioning and mounting are shown in Fig 11 - 11. Only the issued falling plates are authorised for use.

24-30. **Target Screens and Zeroing Targets.** To zero target rifles that have an ME exceeding 4500J on MOD ranges zeroing targets are to be fixed to screens mounted in gallery frames on gallery ranges. The club are to set sights for 600m for zeroing at 200m and check that the fall of shot at the point of impact is central on the target screen. Harmonisation and other targets screens used on barrack ranges are illustrated in Fig 24 - 5.

Target Holdings

24-31. The types and quantities of targets held on a range will vary greatly and will depend on local demand. Ranges should not hold large stockpiles of targetry consumables but rather to demand as and when required to enable the procuring authority to efficiently use enabling contracts to meet demands. This will include regular and reserve forces, cadets, and MOD Police (MDP) for training and competition. Only those targets and Target Mechanisms approved by the appropriate authority may be used.

Maintenance

24-32. Responsibilities.

- a. **DE&S TSSP.** Provides spare parts for Target Mechanisms and new systems to IOC.
- b. **Equipment Manager (EM).** In addition to the responsibilities stated in paragraph 24-05, the EM is required to certify that target systems are safe after installation, repair, and maintenance.
- c. **Targetry Support.** Approved targetry is supported through DIO's Strategic Partner contract by the Targetry Support Division of the Support Provider.

All dimensions in metres unless otherwise stated

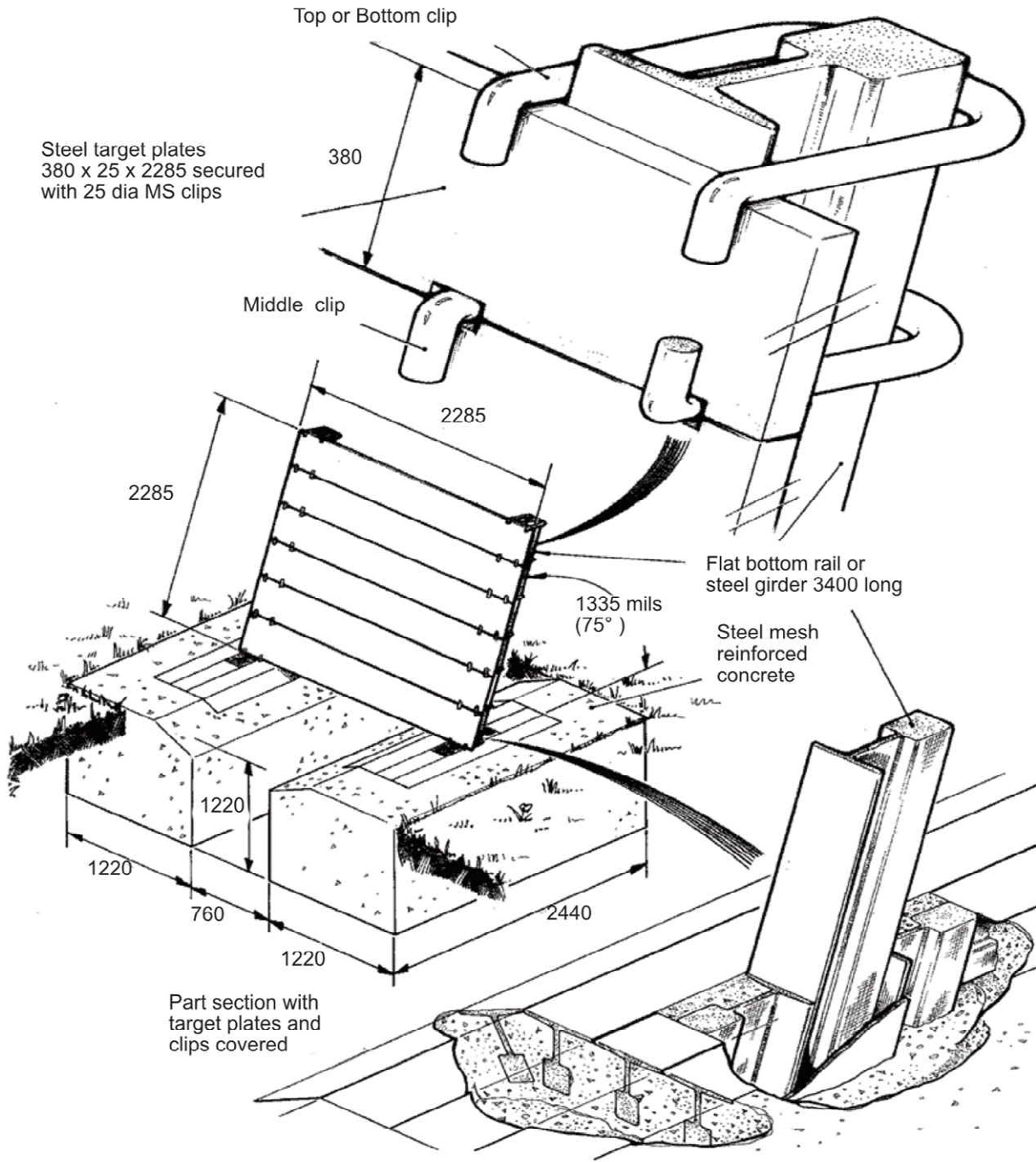

Fig 24 - 1. Horizontal Plate Hard Target

.ll dimensions in metres unless otherwise stated

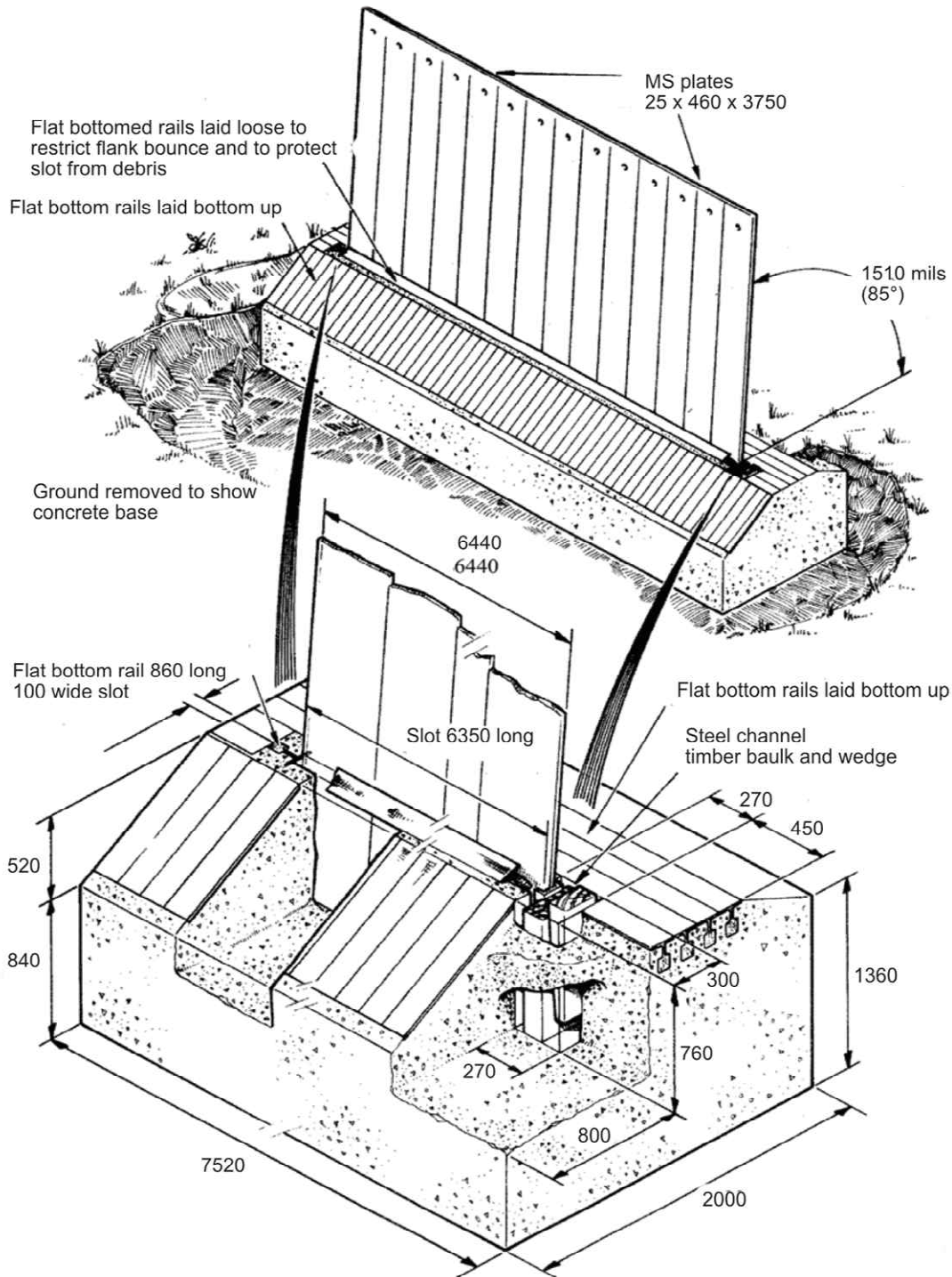

Fig 24 - 2. Vertical Plate Hard Target

All dimensions in millimetres

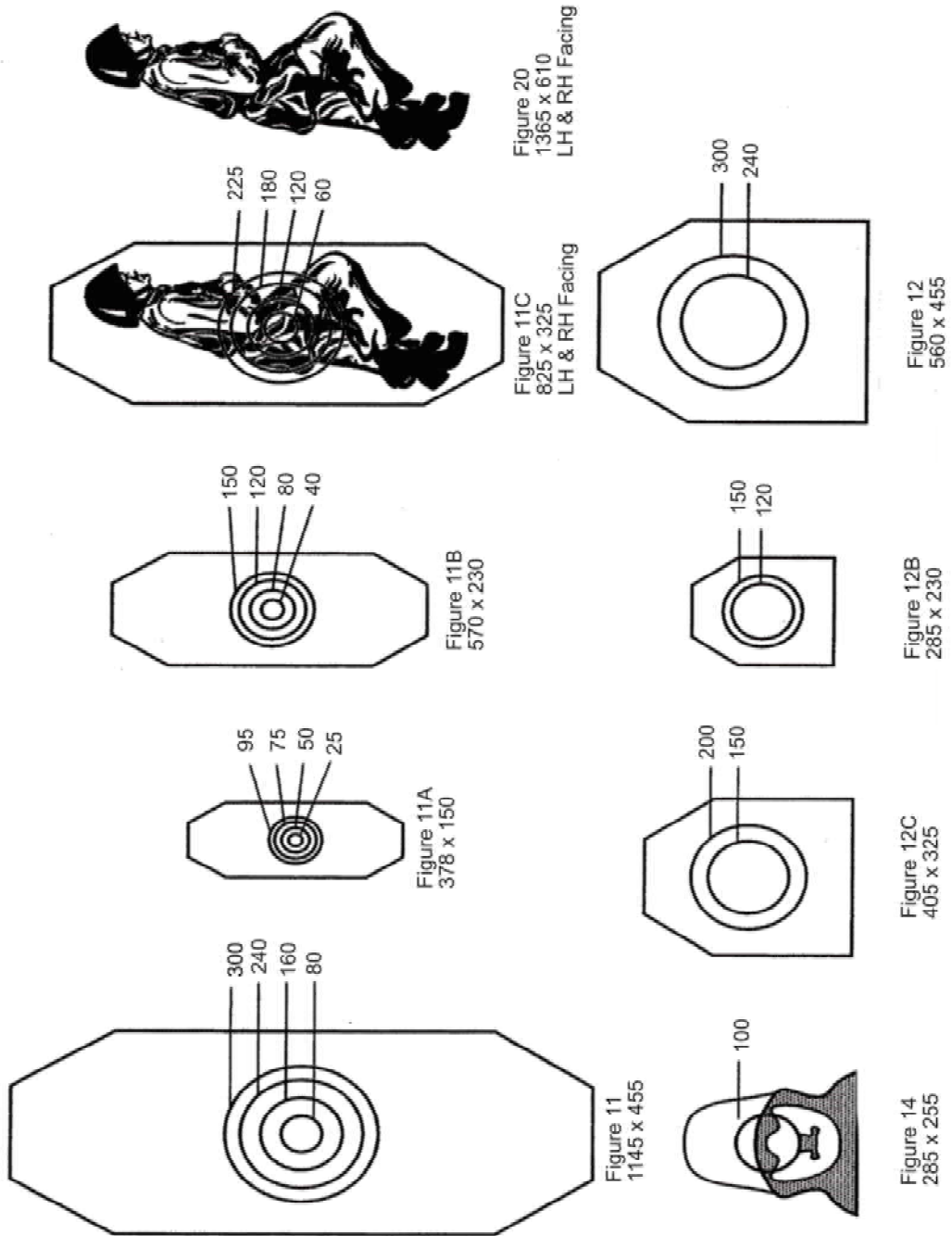

Fig 24 - 3. Standard Figure Targets

All dimensions in millimetres

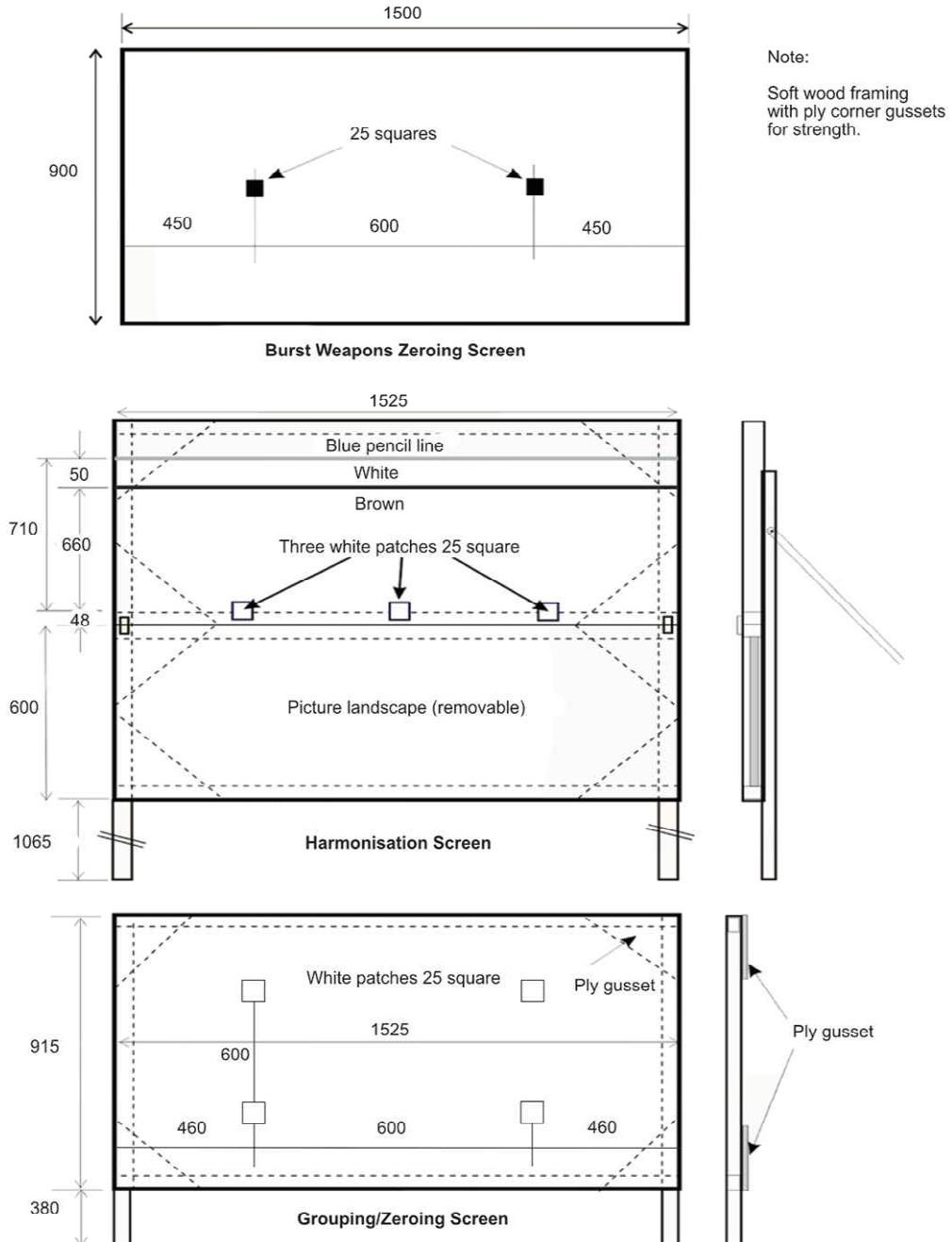
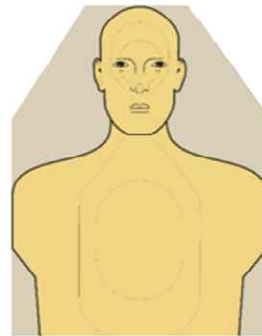
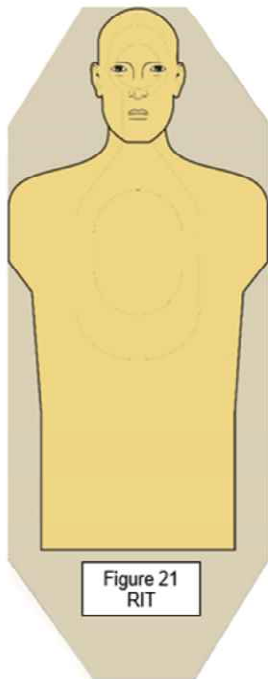

Fig 24 - 4. Barrack Range Target Screens



RIT = Rapid Incapacitation Target

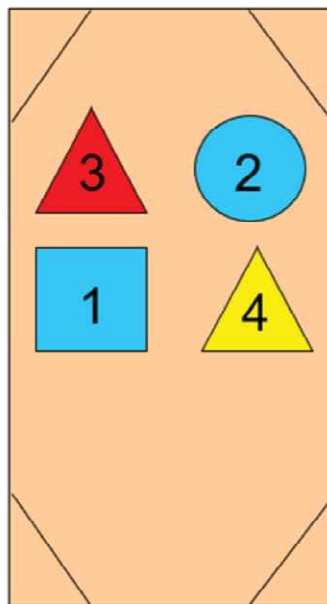
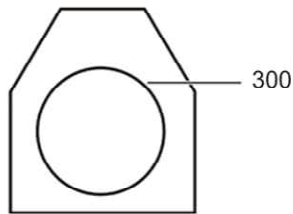

Figure 28

Fig 24 – 5 Close Quarter Marksmanship (CQM) Targets

All dimensions in millimetres unless otherwise stated



Cadet No 12
560 x 455



Cadet 200yd
Tin Hat

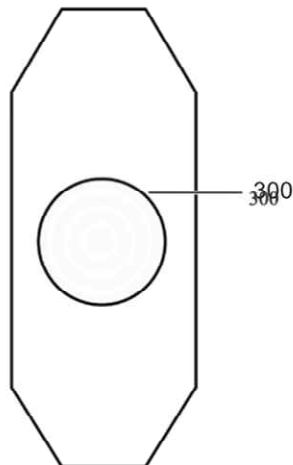

Cadet No 11
1145 x 455

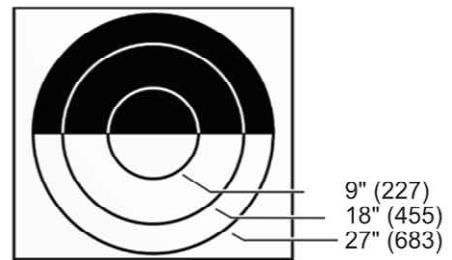

Cadet 300yd
Tin Hat

Fig 24 - 6. Cadet Targets

All dimensions in millimetres

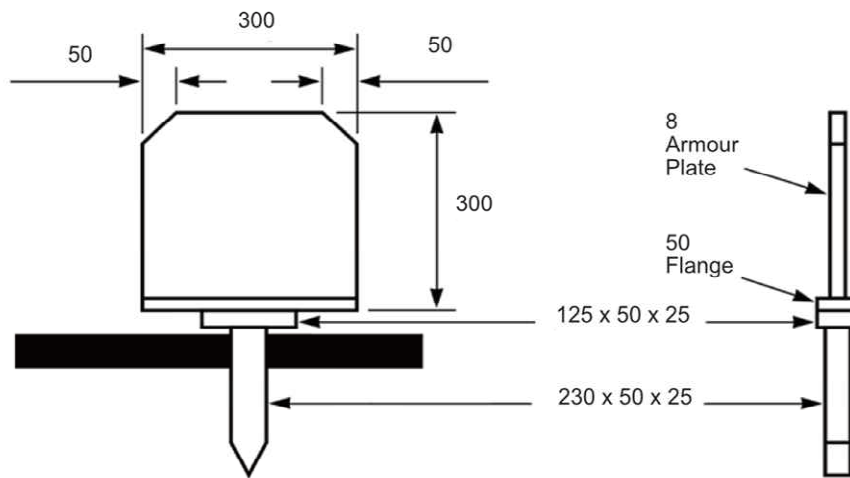

Falling Steel Plate
 (catalogue of Royal Engineer Materiel)
 Army Code 13535 Pt No. 6920-439-0248)

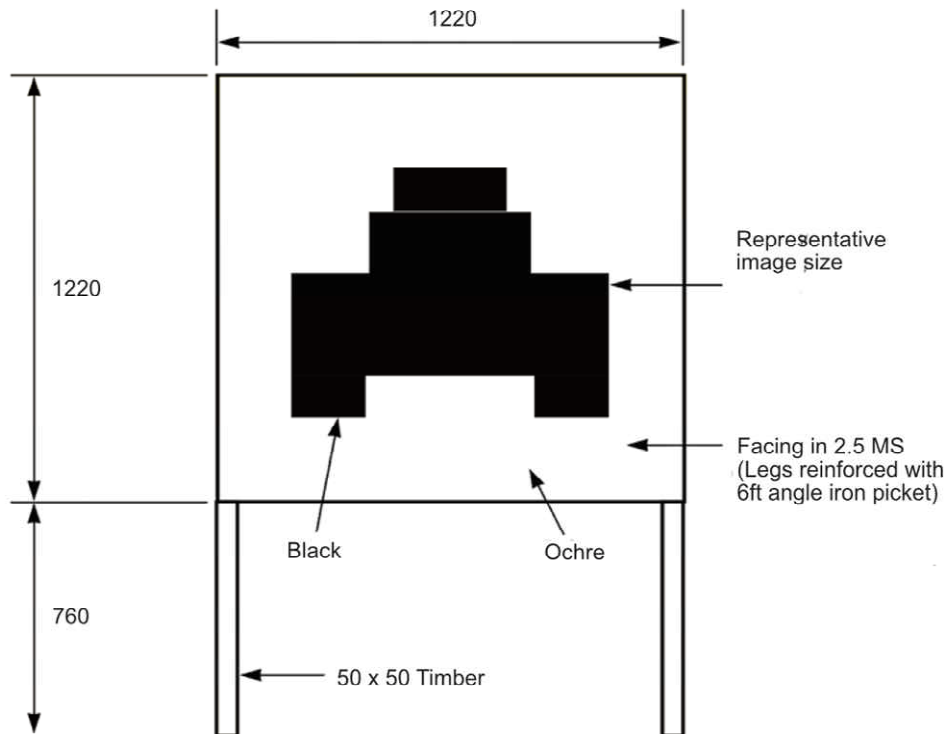

Head on Tank Target

Fig 24 - 7. Falling Plate and Head-on Tank Target

All dimensions in millimetres

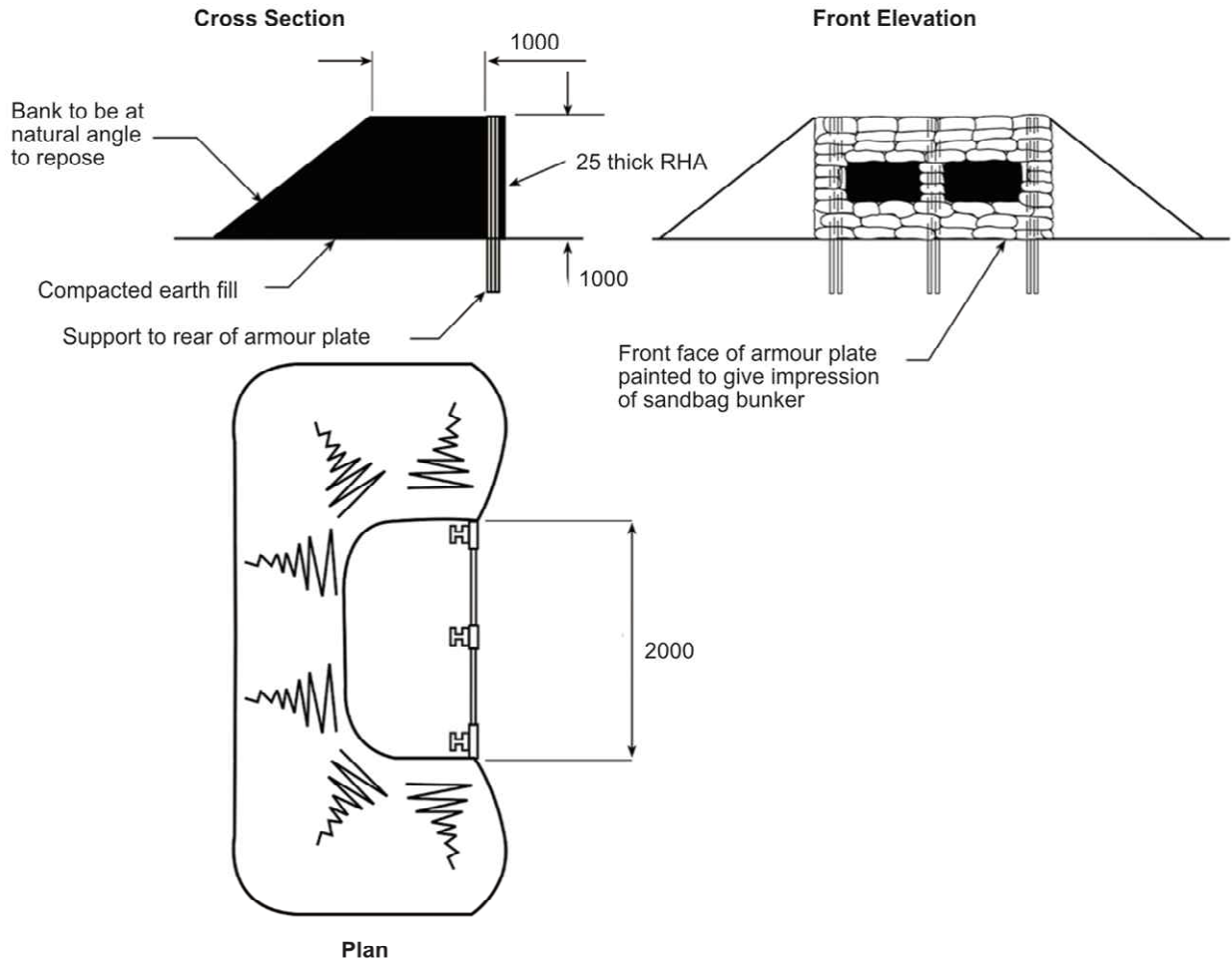

Fig 24 - 8. UGL HE Targets

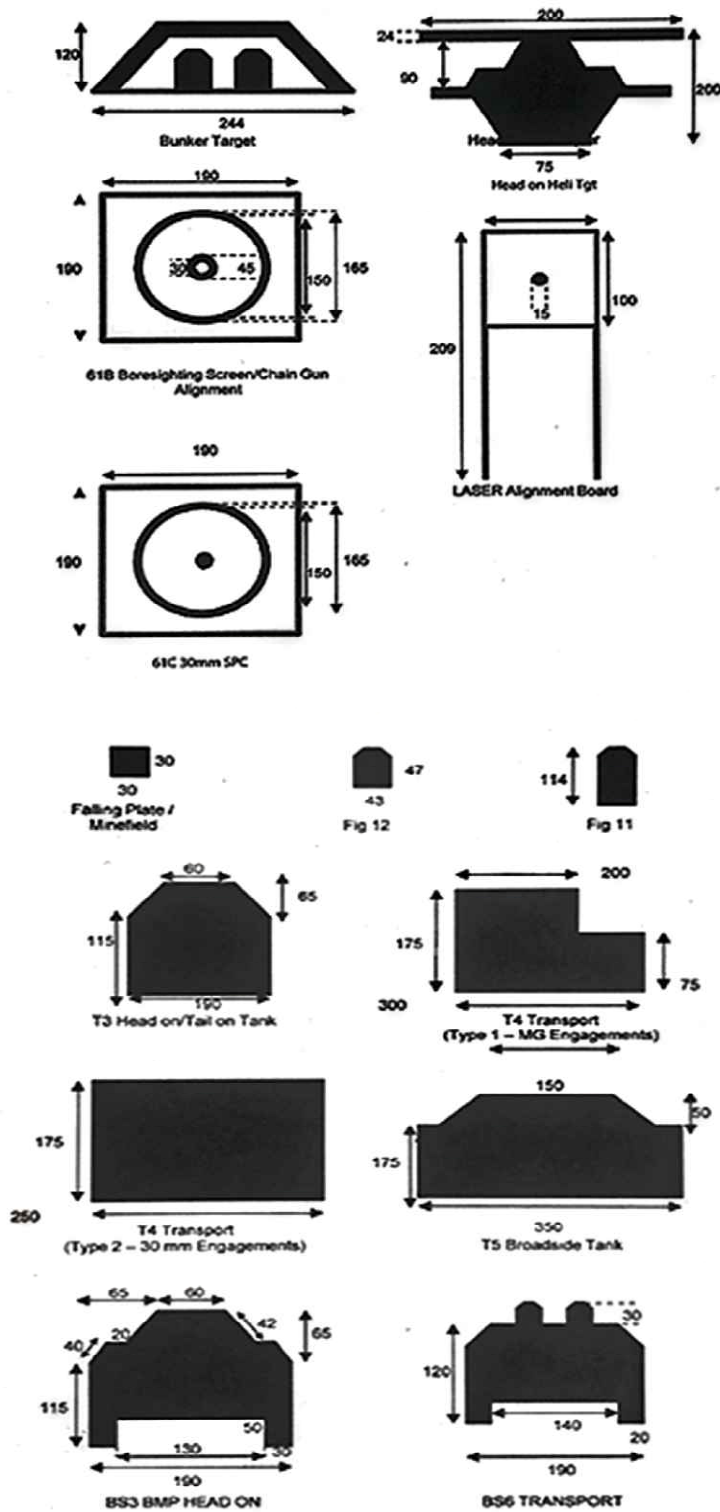

Fig 24 - 9. AFV Targets

Chapter 25 - Control of Hazardous Substances in Indoor Range

This Chapter lays down the MOD requirements to ensure that exposure to emissions from service weapons in indoor ranges and ranges with enclosed or semi enclosed firing points do not generate a hazard to those who enter. It sets out the control measures to be taken to protect those who enter such ranges.



25-01. **Environmental Health Hazards Covered.** Not all emissions from weapons are of sufficient quantity to present a measurable hazard in normal use. Control of the pollutants given in this chapter are assumed to cater for those other emissions not listed, however in certain extreme circumstances this may not be the case. Where extremely high volumes and rates of fire are to be used additional monitoring and control measures may be required. The following emissions from service weapons and resultant dust have been identified as potentially hazardous in some circumstances:

- a. Lead.
- b. Unburnt Propellant.
- c. Accumulated Dust.
- d. Carbon Monoxide.

Hazards

25-02. **Lead.** Inhalation and ingestion of lead can be hazardous to health. When a weapon is fired, the hot gases produced by the propellant burns the lead from the base of the bullet, producing lead fume. Lead may be present in the primer and significant quantities of lead fume can be released along with the ejected case. This occurs with both live and blank ammunition that have lead present in the chemical makeup of the primer. Lead particles are also stripped from unjacketed bullets as they travel down the barrel and are subsequently released into the air around the firer. In addition, lead dust is produced when the bullet impacts sand or steel bullet catchers at the end of the range. Lead will also be present in any dust filtered by any extraction system fitted. All personnel in an indoor range are exposed to the lead hazard produced by firing. In a well-maintained range, the degree of exposure is generally low, dependent upon the number and nature of rounds fired, and is mitigated by the effectiveness of cleaning and any ventilation provided. Personnel such as RCOs, supervisors and coaches are likely to be exposed for longer periods than the

firers. Inspection, cleaning, and maintenance staff will be exposed to residual dust in the range because of their activities. Movement forward of the firing point should be kept to a minimum as this is where lead levels will be higher. Provided that appropriate dust filters have been correctly installed and maintained within the extract ventilation system there should be no risk of exposure, externally, from the exhausted air extracted from heavily used ranges.

- a. **Low Use 0.22" Range.** Low use is defined as 2 or 3 sessions per week and an average total of up to 500 rounds (.22") per week, 26,000 rounds per year. In exceptional circumstances such as an unexpected shortage of RCOs or coaches during a busy cadet training weekend or camp this limit may be extended to 1000 rounds per week provided no individual is not exposed to more than 2000 rounds per month.
- b. **High Use 0.22" and Centre-fire Weapon Ranges.** These are high use .22" ranges firing greater than 26,000 rounds¹ and all other ammunition natures up to a maximum of 150,000 rounds per year.
- c. **Very High Use Ranges.** These are ranges where usage exceeds 150,000 rounds per year. Such ranges may require additional control measures, increased ventilation, and an enhanced cleaning regime dependent upon the volume of rounds fired and the type of ammunition nature.
- d. **Operational and Specialist Ranges.** In extreme circumstances certain ranges may not have mechanical ventilation due to restrictions based on location, use, or other factors. Within these facilities the exposure to lead is controlled by local mitigation measures.

25-03. **Unburnt Propellant.** Unburnt propellant is also released into the range when a SA is fired. It not only produces a hazard but also adds to the problem of controlling lead pollution. Long barrelled weapons with a good breech seal (obturation) may eject less than 2% unburnt propellant but some pistols can eject more than 7%. Most unburnt propellant falls in the firing point and immediately in front of the firers but some will be distributed down range and may be collected in the dust filters. If unburnt propellant is allowed to accumulate in the range, particularly out of sight behind wall cladding or fixtures, it could become a significant hazard. There is currently no simple means of measuring levels of unburnt propellant. However, it can be assumed that it will always be present in dust, whether visible or hidden, in the range if that range has been used during the period.

25-04. **Accumulated Dust.** Any dust allowed to accumulate in a range is likely to contain both lead and unburnt propellant. If made airborne either by movement of air or the shockwave created by the blast from the muzzle, it can become an inhalation hazard and may contaminate both the firers clothing and other objects and material in the range. Firers in the prone position and personnel inspecting, cleaning, or maintaining the range are most at risk from this hazard. When dust is collected, such as in a spark-free vacuum cleaner bag, or if permitted to accumulate, it can become an explosive hazard.

¹ Some .22" facilities may occasionally peak over the 26,000 rounds "High Use" threshold due to concentrated periods of use i.e. concentrations of Cadet Summer Camp, etc. In such circumstances the facility may still be classed as a "Low Use Range" with the periods of concentrated use being mitigated with focused daily cleaning and possibly flanked with an additional "Range Deep Clean"

25-05. **Carbon Monoxide.** Carbon Monoxide (CO) is released into the air each time a weapon is discharged. The amount of CO expelled is dependent upon the ammunition cartridge used. These gasses are light and will disperse in the direction of any air flow. This hazard need only be considered in ranges that have no mechanical or natural ventilation, all ranges with small, enclosed firing points and ranges with particularly high volumes of fire from inside a closed or semi-enclosed firing point.

UK Regulations

25-06. **Control of Lead at Work Regulations.** The following terms have been extracted with a summary from the Control of Lead at Work (CLAW) Regulations and Approved Code of Practice. For a full explanation refer to the CLAW Regulations.

Table 25-1 - CLAW Regulations

Ser	Term	Summary
1	Action level	Blood-lead concentration of: women of reproductive capacity 25µg/dl young person 40µg/dl others 50µg/dl
2	Biological monitoring	Includes measuring of a person's blood-lead concentration.
3	Control measure	Measures taken to reduce exposure to lead such as systems of work, cleaning, engineering controls and the provision and use of PPE.
4	OEL limit Reg.2	Occupational Exposure Limit for lead - 0.15mg/m ³
5	Risk assessment. Reg.5	Identify those who may be exposed to significant levels of lead in air and apply standard Risk Assessment principles. [Identify hazards, eliminate those that may be eliminated, prioritise the remainder and apply control measures to reduce as far as possible the residual hazards.]
6	Significant exposure Reg.2	Where an employee is or is likely to be exposed to ½ OEL i.e. 0.075mg/m ³ to ingest lead. to be exposed to lead alkyls.
7	Young person Reg.2	Has not attained the age of 18.

Ser	Term	Summary
8	Intermittent exposure Reg.5	Exposure to lead compounds for only a few hours over a 40hr week but that exposure may exceed ½ OEL over an 8hr period. If: exposure level is below OEL when averaged over 8hrs. is below ½ OEL when averaged over 40hrs. no substantial risk from surface or skin contamination.
9	Control measures Reg.6	ventilation - sufficient general ventilation. reduce exposure to minimum. regular cleaning - wet methods. prohibiting eating and drinking. provide washing facilities.
10	Air monitoring Reg.9	Required where the employer assesses that employees may be exposed to significant levels of lead in air. Maximum period between monitoring is 12months.
11	Monitoring records Reg.9(5)	Kept for min 5yrs.
12	Medical surveillance	For those likely to be or are exposed to significant (Serial 6) levels of lead in air and all other control measures to avoid this situation are exhausted, those individuals are to be placed under Medical Surveillance. HSE require such monitoring to be coordinated through the Employment Medical Advisory Service (EMAS). In such cases refer to the respective Service Environmental Health Authority for advice.

25-07. **Carbon Monoxide.** The UK Regulations relating to the control of exposure to CO are contained in the Control of Substances Hazardous to Health (COSHH) Regulations. The Regulations state that control of exposure will only be treated as adequate if the principles of good practice are applied and the workplace exposure limit is not exceeded. The Army Medical Directorate Environmental Health Monitoring Team (AMD EHMT) can provide advice and support in this area. Below are the long and short term, Time Weighted Average (TWA), CO workplace exposure limits published in the health & safety Executive's document EH40/2005.

Table 25-2 – Workplace Exposure Limit (WEL)

Long term exposure limit (8hr TWA reference period)	Long term exposure limit (8hr TWA reference period)	Short term exposure limit (15min reference period)	Short term exposure limit (15min reference period)
ppm	mg.m ³	ppm	mg.m ³
20	23	100	117

25-08. **Category of User.** There are several categories of range user to be considered under the CLAW regulations.

a. **Military Trainees.**

- (1) Full time operational training (MDP, SF etc).
- (2) Cadets, intermittent or regular use.
- (3) Cadets, dual use ranges.
- (4) Minors (under 18) and women of childbearing capacity.

b. **Controlled Personnel.**

- (1) Full time trials and development staff (Military and civilian).
- (2) RCOs and Safety supervisors.
- (3) Range Inspectors.
- (4) Cleaners / Contractors.

c. **Licenced Clubs.**

Assessment

25-09. **Range Administering Unit Responsibilities.** RAUs are to assess each of the indoor ranges in their area of responsibility to determine the level of exposure to lead in air and CO as set out in paragraphs 25-05 & 25-17. Where ranges or TERP facilities, firing ammunition natures other than rim-fire rifle, are used full time or rim-fire rifle ranges exceeding 26,000 rounds per year they are to undertake full lead in air monitoring to establish the Occupational Exposure Limit (OEL) for that range and for each particular use. For rim-fire rifle ranges firing less than 26,000 rounds per year and lack an input fan, relying on natural ventilation, a Lead in Air assessment should be conducted; this assessment will remain valid until such time that the range or usage change. Some TERP ranges for instance are used also by others such as MDP. These ranges are to be monitored for each type of use. If a range is used by more than one group of users, each type of user shall be assessed.

25-10. **Factors Included in the Assessment.** The lead and CO exposure assessment should consider the nature of all activities taking place in the range including dry training, inspecting, maintaining, monitoring, and cleaning, as well as all shooting practices. The assessment should consider both users and visitors. Personnel such as RCOs, supervisors and coaches, who are employed routinely in the range are potentially at the greatest risk as they may be in the range for extended periods whether firing is taking place. Cleaners, works officers and inspectors are likely to be exposed to higher levels of lead for shorter periods.

Air Monitoring

25-11. **Requirement.** Full lead in air monitoring is to be carried out in accordance with current CLAW Regulations where the risk assessment indicates that anyone using the range is liable to receive significant exposure to lead and in the following circumstances:

- a. When a new or a refurbished full time permanent use indoor firing range is commissioned.
- b. An existing indoor range has a change of use that may expose users to significant levels of lead or rim-fire rifle ranges that has more than 26,000 rounds fired in it each year.

25-12. **Air Monitoring.** Air monitoring may be carried out by the Service Environmental Health Monitoring Team (EHMT) staff or a specialist contractor. For CO it is a direct measurement undertaken in the range. For lead, air filters are placed on the firers and at several points down range during peak maximum firing in the range. The amount of lead collected by these filters is then measured to determine the lead in air levels for that range.

25-13. **Recording Results.** All monitoring must be recorded in the MOD Form 906 series. A certificate giving the results should be provided and displayed following each measurement of lead in air from air monitoring stating the conditions, if any, under which the range may operate.

25-14. **Significant Levels of Lead in Air.** If following lead in air assessment of a range indicates that exposure to lead is significant, i.e. greater than $0.075\text{mg}/\text{m}^3$, then RITT should be consulted to determine the way forward. Where an assessment finds that there is a significant level of lead at the target end of a range personnel who maintain and inspect the bullet trap are to, if not already doing so, undergo medical surveillance.

25-15. **Significant Levels of CO.** In ranges where there is little or no air flow, particularly in smaller firing rooms, it will be necessary to improve the ventilation arrangements if personal CO exposures exceed the OEL.

Responsibilities

25-16. **RAU.** The RAU is responsible for ensuring that anybody using or working in its indoor range is not put at unacceptable risk from hazards listed above. They are to ensure the following:

- a. **Works.** Where ranges with ventilation systems depend on the system's efficiency to meet CLAW Regulations (such as high use and centre-fire ranges), the systems are to be subject to annual inspection, thorough examination, and test by a current and competent person. This is required to determine the suitability of the system and future inspection and / or maintenance. Works officers are to ensure that deep cleaning by contract is properly completed in accordance with paragraph 25-29b. RITT are to be consulted by Project Sponsors, Property Managers and RF&C Works Officers when indoor ranges are to be constructed or modified. Where the ventilation system efficiency is not a factor in meeting the CLAW Regulations (such as low use rim-fire ranges) it is sufficient to ensure that the ventilation system is in good working order and that it is maintained to manufacturers recommendations, where available.
- b. **Information and Training.** Directors and Heads of Establishments (HoE) are responsible for ensuring that adequate information and training on the precautions to be observed are given to all personnel under their control who operate, use, maintain or clean indoor ranges on the risks from lead and unburnt propellant. Local Health & Safety officers can provide information and training on the correct use and disposal of PPE. Unit Fire Officers should be consulted where units collect and store dust from

ranges that have been used for live firing that will contain small amounts of unburnt propellant.

c. **Range Usage.** The CLAW Regulations require that the number of persons exposed should be reduced to a minimum. An indoor range should therefore not be used for any purpose other than weapon training or evaluation. Where it is necessary for a range to be used for other purposes, the RAU must ensure that it is free of all surface dust prior to use, refer to paragraph 25-30.

Range Design

Design

25-17. **Design Concept.** The design of indoor ranges must address each of the hazards listed in this chapter as far as is reasonably practicable. The aim of the design should be to provide sufficient fresh air into the range to ensure that lead particles and fume generated on the firing point(s) are taken clear of the breathing zone. It will not be possible to take all lead dust out of the range as most will settle out between the firing point and bullet catcher. The range envelope should be designed in such a way to minimise air turbulence and have surfaces that are easily cleaned.

a. **Low Use 0.22" Ranges.** Tests have shown that this type of range will be catered for by a robust cleaning regime and a simple ventilation system.

b. **High Use 0.22" and Centre-fire Weapon Ranges.** These ranges will require a very robust cleaning regime and a ventilation system that combines air speed, air flow and air changes to ensure that exposure to lead is as low as reasonably practical.

c. **Very High Use Ranges.** Where a range falls into this category a very robust cleaning regime is essential as well as a complex ventilation system that exceeds the requirements, especially in terms of air changes may be required. Such systems will need specialist design.

d. **Operational and Specialist Ranges.** In extreme circumstances, such as where power is not available, the use of natural ventilation combined with limitations on use may be used to mitigate issues of exposure to lead. These ranges also include complex room and building layouts where linear airflow may not be achievable, such as shoot houses. RITT are to be consulted to determine if mitigation measures are suitable for compliance.

25-18. **Design Solution.** Each range will have different problems to address. Clearly the ideal solution is to remove contaminants at source with local exhaust ventilation. Where this might be possible in test ranges with fixed firing benches it will not be possible for variable firing positions on several firing points. A combination of local control (directed airflow) and dilution should be achievable in most circumstances.

25-19. **Air Flow Within the Range.** The ideal air flow is a linear flow pulled down range with an extraction system rated 10% greater than the inlet producing a negative pressure down range. For low use ranges this 10% is a recommended figure, whereas for high use ranges it is a minimum. The optimum design to deliver steady air flow across a single firing point is to bring air into the range through a full cross-sectional grill. This is clearly an expensive proposition as such volumes of air may need to be heated. An alternative solution is to provide positional input behind the firers. Where firing takes place from

prone, kneeling and standing positions directional vents may provide a solution. All solutions should ensure there are no "dead zones" or excessive turbulence generated within the range. Where there are elements that may affect the performance of the ventilation system such as air bricks, holes, gaps, or other openings down range of the firers, they are to be sealed up.

25-20. Air Speed. The capture velocity (the airspeed at which lead particles remain airborne) for lead is such that it would be impractical to achieve, thus air speed is used only to move lead fume and particulate out of the firers breathing zone. During trials it was observed that the greater the air speed over the firers the more turbulence in front of the firers breathing zone. Optimum air speeds to minimise such turbulence recorded were 0.15 - 0.2m/s. Air speeds of 0.1m/s or less will not provide sufficient fresh air in the range. Air speeds more than 0.3m/s may need to be heated. In ranges with more than one firing point it may be necessary to increase the air flow at the rear of the range to ensure adequate air flow over the firing points down range. Complex solutions involving intermediate air intakes should only be considered in ranges that are heavily used daily. In low use ranges where there is a simple fan input (single or multiple) and simple extract fan (single or multiple) it is sufficient to ensure the fan is inputting air at the firing point and extracting air at the target end. A wet hand or strand of cotton is all that is required to check this. With these simple fans efficiency is not such an issue. Where there is air handling plant, ductwork and filters the inspection of the air handling system should be undertaken by competent mechanical engineers in accordance with the manufactures recommendations.

25-21. Air Changes. Domestic and office designs often revolve around the number of air changes per hour (AC/H) to establish comfortable conditions. In ranges the issues are local air flow and dilution. Air changes can of course be likened to dilution, but it will not ensure local airflow over the firing points has been achieved.

- a. **Low Use 0.22" Ranges.** For Low Use Ranges the combination of range volume, average number of rounds fired per session, number of personnel exposed, and positions of input and extraction fans should be taken into consideration to Risk Assess the degree of exposures to firers. Table 25-3 below gives a guide to the suggested air changes, which will then be modified by the aforementioned factors.

Table 25-3 - Guide to suggested air changes per hour in low use ranges

Number of rounds fired annually	Air Changes Per Hour
0 – 5,000	1
5,000 – 10,000	2
10,000 -13,000	3
13,000 – 17,000	4
17,000 – 22,000	5
22,000 – 26,000	6

- b. **High Use 0.22" and Centre-fire Weapon Ranges.** It is expected that for most High Use ranges air change rates of between 6 - 10 changes / hr will deliver adequate dilution.
- c. **Very High Use Ranges.** For very high use ranges it may be necessary to exceed 10 AC/H.
- d. **Operational and Specialist Ranges.** RITT are to be consulted to determine air change rates required.

Air Extraction

25-22. **Extraction System.** For high use range the air extraction system should provide an air extraction rate that is at least 10% greater than the air input to assist in pulling a linear air flow down range. For low use ranges 10% is recommended. The extractor unit(s) will need to handle dust and unburnt propellant safely. Access for maintenance and inspection is essential. Air systems are to be switched on 20 minutes before use of the range and left on 30 minutes after use to ensure the systems are running to optimum capacity and that any residual dust is removed from the system after firing ceases.

25-23. **Extraction Filter.** The requirement for extract filtration will depend upon several factors which include but are not limited to; the number of rounds fired, nature of rounds and primers, location of where the extract vents to, and local environment. The extract filter system, where fitted, must be suitable to hold unburned propellant safely. Replacement instructions must be clearly displayed warning of the hazards presented by filters containing lead dust and unburned propellant. Refer also to Building Regulations Part F for location of the extract.

Inspection, Cleaning, Hygiene, Records and Signs

Inspection

25-24. **Inspection of Ranges Used for Firing.** Between the annual and independent inspections, the RAU is to ensure the following conditions are maintained:

- a. The cleaning regime is effective. The cleaning regime is to ensure there is no accumulation of dust in the work areas of the range. Any visible dust will contain both lead and unburnt propellant.
- b. No areas to harbour dust. Equipment, material, apertures, or areas in the structure where dust may gather out of sight are to be avoided.
- c. The bullet catcher is maintained to ensure backsplash will not result from attrition of the trap and that there is not a build-up of bullets or bullet debris captured in the anti-backsplash curtain, where fitted. Cleaning the bullet trap including any anti backsplash curtain is to be undertaken only by current and competent personnel or specialist contractors.
- d. All ventilation equipment is to be installed and handed over to the MOD iaw with direction given in this document; designs reviewed by RITT, installed iaw manufacturers literature, to be the subject of a MOD Form 1057 series BoO handover. MOD Form 1057 series BoO shall include:

- (1) The handover of literature / manuals specifying the best practice inspection testing and maintenance regime for the equipment and the required level of competence of those undertaking the work.
- (2) Appropriate demonstration of the equipment and what an operative is to do.
- (3) Training of operatives if required.
- (4) As well as the focus on the equipment the RAU are to reassure themselves that the equipment is delivering the necessary output:
 - (a) For low use ranges air flow at the firing points demonstrated by use of smoke generators to confirm linear air flow (rate not critical).
 - (b) For high use ranges.
 - (i). The necessary air speeds are being achieved and/ or EHT tests / monitoring during annual LIA tests.
 - (ii). The necessary volumes of air changes are being achieved.
 - (iii). The appropriate pressure differences are being achieved.
- (5) Very high use and specialist ranges. These ranges will have bespoke ventilation systems and as such will need to be tested in relation to their design specification.
 - e. Any change in use of the range or any increase in the amount of dust generated the RAU is to initiate a further risk assessment to determine if this results in a change in the level of lead exposure.

25-25. **Dust.** The level of dust in the range is a matter of observation. Any dust generated from the firing of weapons must be considered a hazard from lead and unburnt propellant. Where this dust is gathered such as in a vacuum cleaner bag or permitted to accumulate, it becomes an explosive hazard. Only spark free vacuum cleaners that meet the specification of ATEX equipment category 1D with T4 135°C for use in zone 20 are to be used.

25-26. **Confined Spaces.** Inspectors may need to work in tubes and behind anti-splash curtains to complete their inspection. In such cases inspectors should refer to the local Authorised Person (AP) Confined Spaces. The risk assessment will also determine what Personal Protection Equipment (PPE) will be necessary. Local RAU shall ensure works inspections ensure all potential confined spaces are identified by an AP.

Range Cleaning

25-27. **Scope.** Maintaining a clean range is the single most effective way to ensure that the risk of exposure to both lead and unburnt propellant are minimised. This section refers to all types of indoor ranges including tube, TERP ranges and ranges with enclosed or semi enclosed firing points. Ranges where dust from live firing is allowed to accumulate in the working areas, firing point and on surfaces down range due to inadequate cleaning, will potentially expose users to significant levels of lead in air and an explosive and / or fire hazard. Local works inspections shall undertake the necessary assessment to ensure

Dangerous Substances & Explosive Atmospheres Regulations (DSEAR) requirements are met.

25-28. **Frequency of Cleaning.** The frequency of cleaning will be dependent on works inspectors risk assessment and how the range is used. Ranges used only one or two evenings a week may need only a weekly clean. Ranges used more frequently and where more rounds are fired may need cleaning after each use. The aim is to ensure there is no build-up of dust in the range working areas and this is a matter of observation. Factors that will influence the frequency of cleaning necessary to keep the work areas of the range free of visible dust include:

- a. The type of SA ammunition fired, e.g. centre-fire pistols firing unjacketed ammunition will create a need for more frequent cleaning than rim-fire rifle. Pistols eject a considerable amount of unburnt propellant and unjacketed ammunition will create more lead dust than jacketed.
- b. The frequency of use and number of rounds fired.
- c. The efficiency of ventilation and extraction.
- d. The porosity of surfaces down range.

25-29. **Cleaning Methods.** So as neither to create a risk from lead and unburnt propellant to cleaning staff or other personnel nor to spread contamination, cleaning the range ceiling, floor and walls, and adjoining rooms is to be by damp sweeping, wet wash cleaners, or by a spark free vacuum cleaner approved specifically for indoor ranges and used in accordance with the manufacturer's instructions. Dry sweeping and dusting are strictly forbidden.

- a. **Routine Cleaning.** Cleaning the range between deep cleans should only be undertaken by staff with adequate PPE and who have received sufficient training on the hazards in the range and use of the PPE. It is essential to ensure the firing point and the area behind and directly in front of the firing point is kept clean and free of visible surface dust. Where it is necessary for firers to move forward to targets, the range floor is also to be kept free of dust. Routine cleaning should not include confined spaces or restricted areas such as that between steel plate and anti-splash curtains. Where there are small tubes (<900mm diameter) routine cleaning should extend as far as possible into the tube with wet wipe without entering the tube. Routine cleaning should include wet wipe of all exposed surfaces to remove any dust and removal of any lead or debris build up in the trap area. Authorised vacuum cleaners or wet wash cleaners may be used for the range floor and, dependent upon type, vertical surfaces in the range. All dust collected in authorised vacuum cleaners is to be disposed of as a hazardous waste. Cadets are not to undertake any cleaning in the range where lead dust may be present. Routine cleaning is not to include confined spaces or restricted areas such as that between the steel plate and anti-splash curtain except in the following circumstances:

- (1) Where permanent staff ensure there is no build-up of dust in the range and trap area by cleaning all surfaces after each shoot or regularly enough to ensure no accumulation of dust on any surfaces.

(2) Where during the monthly inspections a build-up of lead is identified as generating a potential backsplash or ricochet hazard or preventing the anti-splash curtains from hanging freely.

b. **Deep Cleaning.** Deep cleaning must be undertaken by specialist contractors and the frequency will need to be established on a case-by-case basis. An example of a deep cleaning contract for ranges is provided at Annex A to Chapter 25. Deep cleaning involves removing all residual dust from the structure including roof spaces, tubes, target, and bullet trap area including any anti backsplash curtains. It is sensible to de-lead and maintain bullet traps just before a deep clean as this process can generate considerable dust. A deep clean is necessary periodically dependent upon range use. As a guide for .22" ammunition:

Table 25-4 - 0.22 ammunition deep clean guide.

Total number of rounds fired irrespective of number of lanes:	Frequency of Deep Clean
0-5000 rounds	Every 2yrs
5000 -26,000 rounds	Annually (reliant on an effective routine cleaning regime)
26,000+ rounds	Every 6 months

25-30. **Dual Use Facilities.** Ranges should not be used for any purpose other than that as a range, noting that air rifle use is considered part of a range though the requirements of Chapter 22 are to be adhered to. However, RAUs with dual use facilities must ensure that prior to the alternate use of the room following use as a range, all surfaces are free of lead dust and unburnt propellant; such a level of cleanliness is realistically only achieved by conducting a deep clean.

25-31. **Personnel Involved in Cleaning.** Only current and competent personnel provided with PPE, including training on its use, and adequate training on the hazards involved should carry out cleaning in an indoor firing range. At no stage should those cleaning ranges enter small tubes (<900mm dia.) unless they are specialist contractors. Minors and women of childbearing capability must not be involved in the cleaning of ranges.

25-32. **Waste Disposal.** Waste generated from routine cleaning in low use (see paragraph 25-02a) .22" and air weapon ranges need not be treated as hazardous waste. Any waste from a high use indoor range which may be contaminated with lead and unburnt propellant is subjected to disposal in accordance with the Hazardous Waste (England & Wales) Regulations 2005. Details are also provided in JSP 418². It is not to be dumped or disposed of as ordinary waste but stored in sealed containers for proper disposal. This includes:

- a. Water and other fluids from a bullet catcher or wet wash cleaners.
- b. Sand from stop butts and bullet catchers.

² JSP 418: Management of Environmental Protection in Defence

- c. Vacuum cleaner waste bag contents and used filters.
- d. Ventilation filters.

25-33. **Authorised Vacuum Cleaners.** Spark free Vacuum cleaners are to be emptied each time after use to avoid build-up of potentially explosive dust. Emptying vacuum cleaners should be conducted with extreme care to avoid dust exposure to the individual and contamination of the surrounding area.

25-34. **Storage.** The waste from ranges should be removed from the range or stored dry in sealed containers and placed in a secure area. Normal HAZMAT labelling should be used in accordance with Chemicals Hazard Information and Packaging for Supply Regulations 2002. Unit Fire Officers will advise on the limits that may be stored dependent on the storage facility.

25-35. **Disposal.** The Hazardous Waste (England and Wales) Regulations 2005 require sites producing hazardous waste to register annually with the Environment Agency. The regulations, together with the List of Wastes (England) Regulations 2005, stipulate how hazardous wastes should be classified and tracked during movement. Transportation of hazardous waste must be undertaken by a registered carrier in accordance with the Controlled Waste (Registration of Carriers and Seizure of Vehicles) Regulations 1998 to a licensed hazardous waste treatment or disposal facility.

Health and Hygiene

25-36. **Washing.** Hand washing facilities are to be conveniently available as all who use the range will encounter dust and range orders are to stipulate that hands are to be washed on leaving the range.

25-37. **Eating, Drinking and Smoking.** Eating, gum chewing, drinking and smoking are forbidden in an indoor training range. All personnel are to be instructed that on leaving an indoor training range not to eat, drink or smoke until they have washed their hands. Permanent staff rest room facilities may be provided separated from the range.

25-38. **Personal Protective Equipment.** PPE, which is normally disposable coveralls, gloves, and dust masks, may be required for routine cleaning and inspecting but must be worn for working, maintaining, and cleaning in, or around, bullet catchers that have accumulated lead dust. Re-usable PPE must be maintained properly and facilities for its storage are to be provided in accordance with PPE Regulations. Where disposable PPE is used, it should be bagged after use and sealed for disposal by authorised contractors.

25-39. **Additional Measures for Minors.** The CLAW Regulations require RAUs to ensure minors and women of childbearing capacity receive particular care, supervision and training when exposed to lead in air at any level. This is only pertinent for those exposed to significant levels of lead in air and require medical surveillance.

Retention of Documentation

25-40. **Records.** The dates of all assessments, maintenance, air monitoring, medical surveillance (excluding health records of identifiable individuals) and inspections of the range are to be recorded in the MOD Range Log (MOD Form 906 series). The reports and details are to be kept in the Range File for a period of at least 5 years, as required by the current CLAW Regulations.

- a. **Monitoring.** The user unit is to keep details of personnel who are exposed to significant levels ($>0.075\text{mg/m}^3$) of lead in air in an indoor range and the period they were present. This may be a copy of the RSD / eRASP / RAM. The records are to be retained for 10 years and are subject to audit.
- b. **Deep Cleaning and De-leading.** All deep cleaning and de-leading is to be recorded, in red, in the MOD Range Log (MOD Form 906 series) together with the name, rank or job status of the person responsible for the overall supervision.
- c. **Ventilation.** The dates of inspections, checks and any failures or defects found in the mechanical ventilation system if fitted are to be recorded, in red, with the name of the inspector in the MOD Range Log (MOD Form 906 series).
- d. **Inspection and Audit.** Records are to be available for inspection by HoE, Service, and Independent Inspectors and, when required, by the enforcing authority (e.g. HSE). The procedures for completing and auditing the range usage record are to be stated in the range standing orders.

Safety Signs

25-41. **Safety Signs.** For signage refer to Chapter 3, for sign format and colours refer to Chapter 2.

Annex A to Chapter 25

Guidelines for Deep Cleaning Contract Small Arms Ranges

Typical Detail for a Range Deep Clean Contract

1. Essential Information to be passed to contractors where pertinent.
 - a. Lead (Pb). All ranges contain some levels of lead in the form of bullets, bullet fragments and dust.
 - b. Unburnt Propellant. Dust in ranges will also contain unburnt propellant which is an explosive hazard when collected in any quantity. In ranges where only air pellets are fired this hazard should not exist.
 - c. Antimony (Sb). In high use ranges that permit 7.62mm or similar ammunition to be fired there may be levels of Antimony more than EU recommended limits.
 - d. Risk Assessment – Confined spaces. There are some ranges particularly where there are small tubes or box sections where the work environment may be classed as a confined space. In all cases it would not be safe to allow personnel to work alone nor allow access into small tubes unless there are personnel monitoring activity from outside the small tube or box section. Advice in relation to Confined Spaces or Potential Confined Areas should be sought from an Authorised Person Confined Spaces.
2. Requirements.
 - a. Range Structure. All internal surfaces are to be free of dust. This includes any open roof structures, furniture, and fixings. Surfaces that may absorb dust are to be pressure jetted where this is possible or vacuumed. Care is required to clean out joints in any surface finishes. Mechanical scrubbing machines are particularly effective for use on floors.
 - b. Bullet Catchers. Cleaning bullet catchers will be dependent upon the type of trap:
 - (1) Steel plate catchers. Remove all bullet debris and wipe down all surfaces. This includes any anti-splash curtain which may contain bullet debris and will be covered in fine lead dust. Buckled, loose or damaged steel surfaces should be reported to the authority.
 - (2) Snail catchers. Remove all bullet debris and wipe down all surfaces. Empty and wash out any wet or dry collection chambers. Report any damage or distortion on impact surfaces to the authority.
 - (3) Granulated rubber or sand catchers. Arrange for de-leading prior to deep clean or combine with deep clean contract and ensure the de-leading is completed prior to starting the deep clean.
 - (4) Lamella / Curtain / Venetian catchers. Remove all bullet debris and wipe down all visible surfaces. These catchers should be dismantled if it is not easily determined that there is no build up within the trap.
 - (5) Vertical wall catchers. Where this type of bullet catcher is sealed at the bottom, bullet debris will collect between the steel plate and the offset anti-

splash tile. A deep cleaning contract should include removing any bullet debris from this gap.

- c. Baffles. Baffles that are sealed at the bottom should be treated as per Vertical wall catchers, above. Baffles that show no indication of bullet strike may not need to be cleaned out.
- d. Electrical fittings. Dust is to be removed from all electrical fittings, lighting, and any switch gear. Where there is an indication that dust is building up in or around any electrical fitting the authority is to be notified.
- e. Air handling plant and fans. All filters in air handling plant and fans are to be removed, cleaned, or replaced in accordance with manufactures recommendations. All ductwork is to be cleaned through. Input and extract fan grills are to be removed and ducts, blades, grills and motors are to be cleaned free of dust.
- f. Requirement Tube Ranges. Small tubes or rectangular section ranges where it is not possible to enter the tube to deep clean are to be deep cleaned with methods that ensure all dust and bullet debris within the tube or box section is removed.

3. Cleaning Guidelines:

- a. General. Deep cleaning contractors are to take every measure to avoid raising dust during cleaning operations.
- b. Ventilation. Any ventilation system in the range is to be run at full capacity during cleaning in the range. The ventilation system, once shut down at the end of cleaning operations, is then to be cleaned as previously described.
- c. cleaning methods. Dry sweeping is prohibited.
- d. Vacuums. Only approved spark free equipment is to be used in ranges apart from those ranges where only air pellets have been fired. ATEX equipment category 1D with T4 135°C; this is required as there is a Category B Zone 20 hazardous area, within the vacuum cleaner.
- e. Cleaning small tube or box section ranges (where access is not possible). A possible method of cleaning could be to use pressure jetting the tube or box section would safely remove bullet debris and dust however the water will need to be collected and removed. Other methods may be available.

4. PPE. The deep cleaning contractor is responsible to assess the hazards in a particular range and provide all operatives involved with adequate PPE and instruction on its proper use.

5. Compliance with Regulations. The contractor is to ensure full compliance with the CLAW Regulations for all work undertaken within the range and the Hazardous Waste Regulations regarding all waste disposals from the range.

6. MOD Form 906 series / Certification. On completion of the works the authority is to confirm that all scheduled work has been completed and the contractor is to sign the Range Log MOD Form 906 series to certify that the deep clean has been completed.

Chapter 26 - Control of Noise from Small Arms Ranges

This Chapter provides advice on environmental noise related issues as they relate to small arms ranges. The Chapter is primarily aimed at those producing justifications for works related to noise reduction around ranges and Range Administration Units (RAU) so they have some insight into the issues and more particularly the control measures available.

26-01. **Control Measures.** Noise in relation to small arms ranges involves protection for those exposed to muzzle blast peak noise levels dealt with under the Control of Noise at Work Regs 2005 (CNWR). MOD policy covering hearing protection on ranges is covered in Pamphlet No 21.

26-02. **Indoor Ranges.** Engineering solutions to minimise the effect of noise are only possible in indoor ranges or where there are enclosed firing points. When analysing the acoustic properties of a room, the sound arriving at the ears, can be considered under 3 headings:

- a. **Direct Sound.** This is the sound which travels directly from the source to the listener. It is the first sound to reach the listener, having travelled by the shortest route at a velocity of approximately 340m/s. Hearing protection is the only means of providing protection from direct sound.
- b. **Early Sound Reflections.** Shortly after the direct sound arrives, the listener receives a series of sound wave fronts which have been reflected one or more times from the walls, ceiling, and any other reflective surfaces in the room. These wave fronts have taken a longer path than the direct sound and therefore arrive later. The later they arrive, the greater their potential for interfering with speech intelligibility. Angled baffles such as those used on the old 94 HEAT range firing points (see Chapter 20) deflect noise away from the firing point. Open texture materials can absorb noise and there are many proprietary noise reduction surface finishes that are suitable for use in ranges i.e. they do not absorb dust.
- c. **Reverberation.** Sound wave fronts are repeatedly reflected from the room surfaces and, because of absorption, gradually grow weaker and weaker. Acoustic surfaces in a firing room will ensure reverberation is minimised.

26-03. **Outdoor Ranges.** Outdoor ranges firing high velocity weapon systems should not be sited within 1km of sensitive buildings, such as hospitals.

Environmental Noise (Noise Nuisance)

Background

26-04. **The Environmental Issue.** Noise is a particular issue for the MOD. Training requires realistic battlefield conditions which include live and blank firing on ranges and training areas, tank exercises, blast vibrations from firing and battle simulation effects, and the use of weapon firing simulators and other similar operations.

26-05. **The Nugent Rule (Historical Reference).** Distance is the most cost-effective reduction measure available as well argued in the Report extracted below.

Report of the Defence Lands Committee 1971-73 by the right Hon. Lord Nugent of Guilford.

Extract

Noise

8.33 We first examined the measures the Services are already taking to mitigate the effects of noisy activities. We learned that steps have been taken, at an airfield where noise problems are particularly severe, to buy surrounding land to ensure that the areas most affected are not developed. This policy of sterilization can, in special cases, make a worthwhile contribution to the reduction of noise nuisance to the public; though it involves the acquisition of more defence land, this land can usually be productively used for agricultural purposes.

Buffer Zones

8.34 We considered whether this policy might have wider applications. In particular, we had in mind the fact that the noise problem which already exists at firing ranges and training areas close to urban areas is likely to get worse as housing and other developments advance closer to the Service sites, even though the volume of noise may not increase. We hold very strongly that this is a matter which needs to be tackled now, and consider that if 'buffer zones' were introduced between Army sites where firing takes place and civilian developments, the worst features of this noise problem could be contained, and in some measure mitigated. We recognize that this poses problems for local authorities as well as the Ministry of Defence; we recommend that it should be tackled jointly, with give and take on both sides. Existing dispositions and problems of land acquisition make it unlikely that this policy can be universally applied, but we would propose its adoption wherever practicable.

Noise Source

26-06. **Sound in the Open Air.** As an observer moves away from a sound source, the sound pressure level diminishes. The rate which this occurs depends on the nature of the source itself and this principle is true if the observer is not too close. Most practical situations may be described in terms of two 'ideal' sources: point sources and line sources.

- a. **Point Source.** The sound source is represented by a point and sound is radiated equally from it in all directions. Every time the distance from a point source is doubled, the level decreases by 6dB. A point source, such as a weapon, which produces a level of 130dB at 10m will produce a level of 124dB at 20m. At 30m, the level will have fallen by 10dB. In other words, when the distance is trebled, the loudness is halved.
- b. **Line Source.** A line source, such as a military convoy, which produces a level of 70dB at 10m, will produce 67dB at 20m. For a 10dB reduction, half as loud as the level at 10m, the observer must retreat to approximately 100m from the source or ten times the original distance.

Natural Dissipation

26-07. **Attenuation in Open Air.** Attenuation due to distance has already been discussed. Wind and temperature gradients also effect sound. Sound travels faster in air as the temperature increases. The absolute speed also increases with wind speed (downwind propagation).

26-08. **Attenuation from existing Screens and Barriers.** In addition to the effect climate has on sound, there are often buildings or similar objects which lie between the source and the observer and prevent line of sight between them. When a sound wave meets an obstacle like a fence or a building, a proportion of it is reflected, and the rest of the wave carries on past the edge of the obstacle. However, the 'bare' edge of a sound wave cannot sustain itself in free space - the vibrating air molecules at the end start themselves to act like sources and radiate in all directions. The result is that a sound wave which has passed the obstacle, bends, or diffracts round it into the shadow zone behind the obstacle.

Natural and Engineering Controls

26-09. **Distance.** This is a simple inverse square law relationship, which at frequencies between 300 - 600 Hz, would give attenuations of 66 dB and 68 dB at 1500 metres and 1650 metres respectively.

26-10. **Ground Absorption.** Sound travelling close to grass covered ground is attenuated as follows:

Table 26-1 - Ground Absorption

Distance from sound source	Frequency (Hz)	Frequency (Hz)	Frequency (Hz)	Frequency (Hz)	Frequency (Hz)
	37.75	75-150	150-300	300-600	600-1200
1500m	4-5	15-0	34-0	45-0	34-0
	Attenuation (dB)	Attenuation (dB)	Attenuation (dB)	Attenuation (dB)	Attenuation (dB)
1500m	5-0	16-5	38-0	50-0	38-0
	Attenuation (dB)	Attenuation (dB)	Attenuation (dB)	Attenuation (dB)	Attenuation (dB)

26-11. **Trees.** When trees are sufficiently dense to mask a highly visible object at 60m, the following attenuations apply:

Table 26-2 – Attenuation from Trees

Frequency (Hz)	37-75	75-150	150-300	300-600	600-1200
Attenuation (dB)	2	3	5	6	7

26-12. **Earth Banks.** Although these block the direct path of sound between weapon and complaint area, earth banks have a complicated effect:

- a. For example, the attenuation due to banks at 3m and 30m from the weapon would be 18dB and 9dB respectively. Should the side of the bank nearest the weapon be vertical the above attenuation would be reduced.
- b. A bank may however cut out, or reduce, the sound travelling close to the ground and hence reduce the ground absorption by about half. To gain 18dB attenuation by means of a bank 3 metres from the weapon, one could therefore lose between 25.5 and 25dB attenuation in lost ground absorption. This effect is uncertain, especially where the ground cover is bushy rather than grassy.
- c. The effect of a bank and its likely effect on ground absorption may be summarised as follows:

Table 26-3 – Attenuation from Earth Banks

Bank sited at 3m from weapon	Frequency (Hz) 37-75	Frequency (Hz) 75-150	Frequency (Hz) 150-300	Frequency (Hz) 300-600	Frequency (Hz) 600-1200
Attenuation due to bank (dB)	9	12	15	18	21
Loss of ground absorption, in dB, due to bank: At 1500 m	2.3	7.5	17	22.5	17
Loss of ground absorption, in dB, due to bank: At 1650 m	2.5	8.3	19	25	19

26-13. **Wind and Turbulence.** Turbulence at the top of a wall may assist the sound to diffract over the wall and reduce the dBs of attenuation as follows:

Table 26-4 – Attenuation from Wind

Wind Speed	Frequency (Hz) 37.75	Frequency (Hz) 75-150	Frequency (Hz) 150-300	Frequency (Hz) 300-600	Frequency (Hz) 600-1200
8 kph	0 dB	0 dB	0 dB	0 dB	0 dB
16 kph	0 dB	0 dB	1 dB	2 dB	4 dB
32 kph	1 dB	3 dB	6 dB	8 dB	10 dB

26-14. **Temperature and Humidity.** A figure of 3 dB attenuation has been taken as typical for temperate summer climatic conditions. The figure represents atmospheric absorption at low frequencies. At high frequencies absorption will be much higher, so much so that high frequency nuisance over these sample distances can be ignored.

26-15. **Temperature Gradients.** These have effects like those of wind gradients and, similarly, are not yet capable of prediction. An inversion may increase sound transmission, but it is not known how often this condition may obtain in any given locale. However at least it could not be combined with the adverse wind direction mentioned above.

26-16. **Theoretical Prediction.** An example is given below of a theoretical prediction of sound attenuation, at distances of 1500m and 1650m from an SLR. As high frequencies, i.e. above 1000 Hz, will be unimportant in the case of small arms, the octave 300 - 600 Hz is used in the example.

Attenuation for sounds in the 300 - 600 Hz octave:

Table 26-5 - Attenuation for sounds in the 300-600 Hz octave depending on distance from weapon

	1500 metres Without Bank	1500 metres With Bank	1650 metres Without Bank	1650 metres With Bank
Distance	66dB	66dB	68dB	68dB
Ground absorption	45dB	22.5dB	50dB	25dB
Trees	6dB	6dB	6dB	6dB
Earth bank 3m from weapon	-	18dB	-	18dB
Wind and Turbulence (assumed 32 kph)	-8dB	-8dB	-8dB	-8dB
Temperate and Relative Humidity	3dB	3dB	3dB	3dB
TOTAL Attenuation	112dB	107.5dB	119dB	112dB

26-17. The sound peak pressure, at the weapon, for the SLR is 159dB. From the table above, at 1500m from the weapon the sound peak pressure would be:

- a. With Bank $(159 - 107.5) = 51.5\text{dB}$.
- b. Without Bank $(159 - 112) = 47\text{dB}$.

26-18. These levels would be barely detectable in an average room and certainly not outside in a normal urban environment. It is emphasised that while these Figs are theoretical, they were found to agree, within plus or minus 10%, with sound measurements taken in a similar situation.

German Range Noise Baffle Solutions

26-19. In 1991 the German, US and UK combined to develop means of reducing noise from tank test facilities, armoured and artillery ranges with fixed firing points and fixed small arms ranges. The methods included absorbing noise walls, barriers, both vertical and earth banks and for the first-time open box units mounted above the firing points and in some cases, ranges. These measures achieved considerable reductions in audible noise beyond the firing points.

Annex A to Chapter 26

If you use assistive technology and need a version of the table in a more accessible format, please email dsa-dosr-prg@mod.gov.uk telling us what format you need.

Measurements of Peak Pressure Levels (dB) and Pulse Duration (milliseconds) for Typical Infantry Weapon Systems

Ser	Weapon/Ammunition	Ear Position										
		Firer		Loader		Instructor or Adjacent Personnel						
		dB	ms	dB	ms	0.3m to Side		1.2m Side		3.0m Side		
(a)	(b)	(c)	(d)	(e)	(f)	(g)	(h)	(i)	(j)	(k)	(l)	
1	SLR / 7.62mm Live											
	0.3M above Ground	160	5.0	-	-	-	-	-	-	-	-	-
	1.5M above Ground	151	0.9	-	-	169	0.5	160	0.5	155	0.5	
	SLR / 7.62mm Blank	150	10.0	-	-	-	-	-	-	-	-	-
2	SA80 / 5.56mm Live	158	-	-	-	-	-	-	-	-	-	-
3	Colt Armalite / 5.56mm Live	151	1.0	-	-	165	1.0	155	0.5	153	0.5	
4	SMG / 9mm Live	157	1.0	-	-	162	1.0	154	0.5	151	0.5	
5	GPMG / 7.62mm Live	162	-	-	-	-	-	-	-	-	-	-
6	Shotgun / 12 bore	155	5.0	-	-	-	-	-	-	-	-	-
7	Pistol / 0.38 inch	157	5.0	-	-	-	-	-	-	-	-	-
8	Pistol / 9mm Live	157	1.0	-	-	-	-	-	-	-	-	-
9	Rifle / 0.22 inch	138	2.5	-	-	-	-	132	2.5	-	-	
10	Mortar 81mm, QE45°	183	11.0	186	8.0	-	-	-	-	-	-	-
	L16 / Charge 5 QE45°	187	3.0	-	-	-	-	182	3.6	173	4.0	
	L16 / Charge 5 QE45°	183	2.7	-	-	-	-	183	2.9	170	4.4	
11	Mortar 2 inch QE45° MK2/2	170	0.9	-	-	-	-	161	0.9	153	0.7	
12	LAW 80 / 94mm Practice A1T	183	-	-	-	-	-	184	-	-	-	

Ser	Weapon/Ammunition	Ear Position									
		Firer		Loader		Instructor or Adjacent Personnel					
						0.3m to Side		1.2m Side		3.0m Side	
(a)	(b)	dB	ms	dB	ms	dB	ms	dB	ms	dB	ms
13	Carl Gustav / 84mm Practice AT	183	8.0	187	8.0	-	-	-	-	182	8.0

Notes:

1. The pulse duration is the total time taken for the pressure fluctuations to decay by 20dB from the peak pressure level.
2. Historic / obsolete weapons / munitions are included in this table to give indicative noise levels, in terms of general order of magnitude, in the absence of other data.

Chapter 27 - Weapon Unloading Facilities

Although SA unloading facilities are not ranges, not licenced nor inspected they have been included in this DCOP for convenience.

27-01. **Purpose.** Guards and patrols carrying loaded SA require an area for safe loading and unloading drills. The unloading bays described in this Chapter are intended for all Service SA used in accordance with established drills under supervision.

27-02. **Limitations.** As the unloading facility is intended to capture the occasional round which has been fired unintentionally, the danger from backsplash cannot be eliminated due to the proximity of the firer to the sand. The unloading facility is not to be used for testing or any other deliberate firing of a SA.

Unloading Facility Construction

27-03. **Siting.** Unloading facilities are intended for outdoor use but may be inside a building if there is no other option. The prime consideration in siting is convenience of use. When constructing the WUF shown in Fig 27 - 1, ideally it should be built against the wall of an existing brick building with no windows or doors close by. It is essential that the back wall of the facility is built and that the bullet catcher is not simply built against an existing wall. Proprietary unloading solutions are to be fixed and maintained in line with manufacturer's instructions. Instructions for use are to be derived from local risk assessment.

27-04. **Facility Materials.** The facility shown in Fig 27 - 1 may be constructed in any form providing the ballistic safety requirements of this Chapter are met. For example, an alternative to the brick sidewalls could be to use either Hesco or DefenCell of a suitable thickness.

27-05. **Bullet Catcher.** The permanent unloading facility normally includes a sand or granulate rubber bullet catcher, details of which are given in Chapter 2. It is essential to safety that the correct grade of sand or rubber is used and maintained in a loose state at an angle of 34° (600 mils) (S). The sand or rubber profile must be maintained to the levels marked on the facility's side and back walls. For low velocity weapons, .22in, 9mm, the depth required to contain a round is 750mm (S) 500mm (C), for high velocity weapons the depth should be 1000mm (S) 900mm (C). The depth can be achieved by elevating the standing position for unloading, so that the barrel is pointed down at an angle into the sand unloading facility. A low velocity bullet catcher must be clearly signed detailing which weapons are permitted.

27-06. **Guide Tubes.** Though not mandated, some users may wish to have guide tubes set into the bullet catcher sand to ensure that the weapon is pointing correctly into the centre of the bullet catcher. Typically, such tubes are lengths of plastic drainpipe (diameter 110mm (4") or larger) that can accommodate the muzzle of the weapons to be used with the WUF. These tubes are to have vent slots or holes cut in them so that if the weapon does discharge the back blast up the tube is minimised.

27-07. **Cladding.** As an additional safety feature, the walls are timber clad, which reduces but does not eliminate danger if struck.

27-08. **Signage.** The WUF is to have appropriate signage to indicate the nature of weapon systems that may be used with the facility and the loading / unloading drills. Any additional information that may be required is to be determined by a local risk assessment. Signs should be locally manufactured and, where practical, follow guidance on layout and sizing as given in Chapter 2. The signage is to be in a prominent position where it can be easily read.

Proprietary Unloading Facilities

27-09. It is recognised that the sand unloading facilities suffer from several disadvantages. They are large, require continual maintenance, and are fixed in a permanent location. An alternative is to use one of several proprietary systems, such as the APC - 100. Such proprietary unloading systems must meet the requirements set out in paragraph 27-10 below. Details of proprietary Weapon Unloading Facilities may be obtained from RITT.

Design

27-10. To be safe a WUF must meet the following criteria.

- a. Capture without penetration, ricochet or backsplash all rounds that might be fired into it. DSA 03.OME Part 3 Volume 2 provides material performance details.
- b. The bullet impact area must be large enough to eliminate the chance of a bullet striking anything other than the trap.
- c. The muzzle is fully contained in a tube or flared aperture. If a tube is used, consideration must be given to venting muzzle blast.
- d. The design must be intrinsically safe with no hidden attrition. Weapons held in the unload position should point naturally at the intended point of impact.
- e. Where pistols are to be unloaded the design must take account of the unloading drills in that the muzzle may be drawn back during the unload.

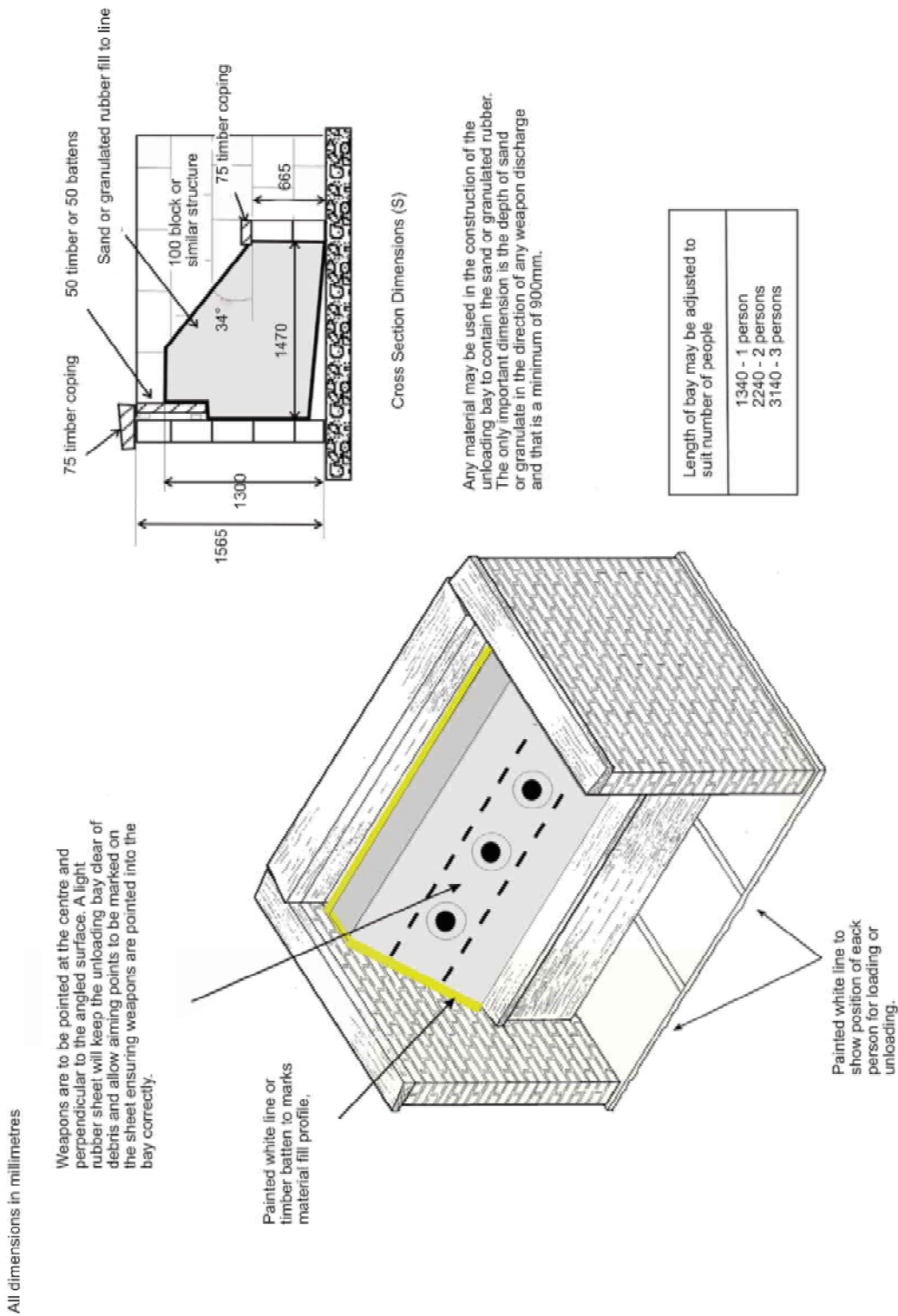

Fig 27 - 1. Sand or Granulate Filled Unloading Bay