



Department for  
Business, Energy  
& Industrial Strategy



**Energy Technology List**

# **UPS: Uninterruptible Power Supply**

A guide to energy efficient equipment listed on  
the Energy Technology List (ETL)



# Contents



## 1. Introduction to the Energy Technology List (ETL)

## 2. Setting the scene – Uninterruptible Power Supply (UPS)

## 3. UPS - technology improvements

## 4. UPS equipment eligible for the ETL

- Static UPS
- Rotary UPS
- Hybrid Rotary UPS

## 5. UPS operating modes

## 6. Parallel operation of UPS

## 7. Further information



# Introduction

---



The ETL is a government register of energy saving products. When you select products from the list you are choosing from amongst the most energy efficient products in the marketplace.

When replacing equipment, businesses are often tempted to opt for equipment with the lowest capital cost. However, such immediate cost savings may prove to be a false economy. Considering higher energy efficient products, means that life cycle costs are reduced, improving cash flow in the longer term.

Businesses can also claim accelerated tax relief through the Annual Investment Allowance (AIA) for investments in plant and machinery equipment. The AIA has been temporarily increased to £1 million from January 2019.

**This leaflet illustrates the benefits of investing in UPS energy saving equipment which qualifies for the ETL.**

The ETL comprises two lists:

- **Energy Technology Criteria List:** defines the performance criteria that equipment must meet to qualify for the ETL;
- **Energy Technology Product List:** is the list of products that have been assessed as being compliant with ETL criteria.

Eligible UPS products on the ETL can be searched at:

[https://etl.beis.gov.uk/engetl/fox/live/ETL\\_PUBLIC\\_PRODUCT\\_SEARCH](https://etl.beis.gov.uk/engetl/fox/live/ETL_PUBLIC_PRODUCT_SEARCH)



# Setting the scene – Uninterruptible Power Supply (UPS)

## Definition

An uninterruptible power supply (UPS) is an electrical system that provides high quality electrical power without interruptions. The mains electrical power supply is connected to the input of the UPS and the output is connected to the customer electrical load. Within the UPS system there are integrated storage systems such as batteries and flywheels which supply energy in the event of a power supply loss.

Key benefits of a UPS system:

- Provides short-term power to a critical load (e.g. server room) during a power outage, allowing time for an alternative supply, such as a standby generator to be brought on-line.
- Protects equipment by filtering a range of electrical disturbances, thus providing a clean power supply.

**UPS units are commonly found in server rooms and data centres. They play a significant role in maximising the availability of systems.**

**UPS modules are often operated in parallel to increase availability and provide extra security of electrical supply to the connected equipment. One or more additional modules are included to maintain capacity in the event of a failure. This is known as operating in 'redundant configuration'. Under these circumstances, each UPS shares the supply but operates at a reduced power level. Or some modules operate at high capacity and others are inactive until needed.**

UPS units not only improve the quality of the electrical supply, but also smooth out any surges, spikes or dips in the power supply which could damage equipment.

### Did you know?

New UPS technology, such as that listed on the ETL, can deliver an estimated 4% energy savings relative to the market average.



# UPS - technology improvements

## Energy Technology List

Since 2014 there have been significant increases in the efficiency of UPS units. The ETL technology criteria have been updated to reflect this:



- Efficiency thresholds of the ETL criteria have been increased over time to only include top performing products.
- Static UPS must now incorporate a high efficiency operating mode and include advanced controls to switch quickly between modes.
- Modular products are required to incorporate advanced control systems to maximise efficiency.
- Whole system (UPS & storage device) needs to be compliant to be eligible for the ETL.



# UPS equipment eligible for the ETL:

## Static & Rotary UPS

Two types of UPS are included in the ETL.

### Static UPS

Static UPS are used for supplying critical loads such as small data centres, and typically range in size from 10kVA to a maximum of 1MVA/unit for the industrial and commercial market.

Static UPS are usually neatly housed in an electrical cabinet inside a building close to the electrical load. They occupy much less space than rotary systems and often use a battery storage system which is housed in the same cabinet.

### Rotary UPS

Rotary UPS tend to be much bigger than Static UPS and individual units typically range from 200kVA up to 2.2MVA.

Rotary systems are generally used to support high power requirements which, when operated as multiple units, can supply a critical load of 50MVA. Rotary UPS are often used in industrial or military applications.

An ETL listed UPS must meet defined energy efficiency levels under various load conditions. In this document, the baseline scenario below, has been used to calculate the potential financial (£), energy (kWh) and carbon savings (tonnes CO<sub>2</sub>) unless otherwise indicated:

- UPS operates continuously, 8,760 hours a year
- All UPS operate at unity power factor
- Price for electricity\* 11.14p/kWh
- Carbon emissions\* for electricity 0.35156 kgCO<sub>2</sub>/kWh

\* BEIS 2017





# Static UPS

Static UPS systems are eligible for the ETL

## Important

Static UPS must now incorporate a high efficiency operating mode and include advanced controls to switch quickly between modes to be ETL listed.

## Simple static UPS system

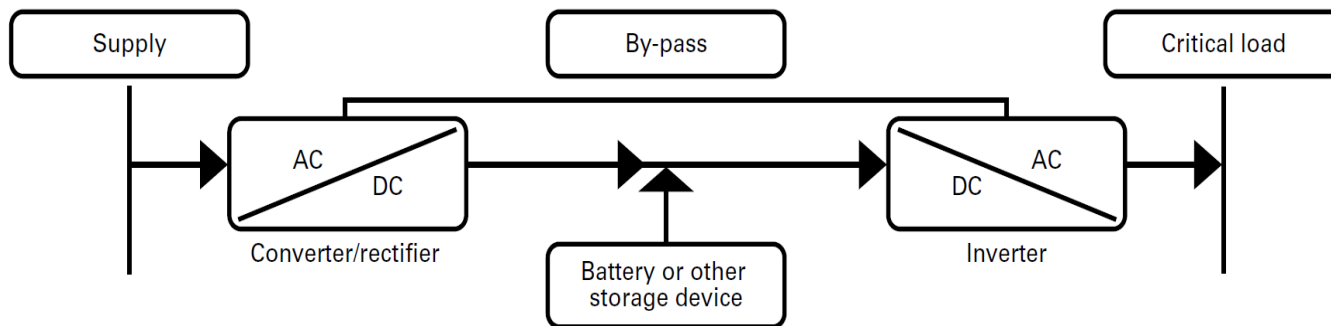

Lithium-ion batteries offer a number of benefits over a valve regulated lead acid battery (VRLA) including faster charging, slower battery discharge and less battery replacements.





# Static UPS

Static UPS systems are eligible for the ETL

## Simple static UPS system



© BPC

### Simple static UPS system

A static UPS usually consists of three main component parts:

- 1. Rectifier/battery charger** – This converts the mains supply AC voltage and current into suitable DC voltage and current needed to charge the battery and power the inverter.
- 2. Storage unit** – This is normally a battery which stores DC electrical energy and power for periods ranging from several minutes to many hours. The most common battery used by UPS manufacturers is the sealed or valve regulated lead acid battery (VRLA). Increasingly, Lithium-ion batteries are now being used. Although they have a higher capex cost, these batteries are said to offer a much lower cost over the battery lifetime. Energy storage for UPS can also be provided by very high speed flywheels, or a combination of batteries and flywheels. When required, the storage unit provides the electrical supply to the critical load through the inverter.
- 3. Inverter** – This converts the stored DC supply (from the rectifier or the storage device) into an AC voltage waveform – stabilised, filtered and regulated to supply the load.

**Example:** For two static UPS units or packages selected from the ETL of 100kVA, operating in parallel and supporting a critical 80kVA data centre load, with an efficiency 5% better than a non-specified product, the potential annual savings are calculated as:

- £4,520
- 40,540 kWh
- 14 tonnes CO<sub>2</sub>e

**With a typical additional capital cost of £16,000 (£56,000 non-ETL capital cost) and lifetime energy and AIA benefits of over £50,000 at today's prices, the financial benefit of choosing an ETL listed product is over 3 times the additional cost. Furthermore with a potential AIA of £13,680 in year 1 plus additional energy savings, the extra capital cost is recovered in under 2 years.**





# Rotary UPS

## Rotary UPS systems are eligible for the ETL

### Energy Technology List

#### Rotary UPS system

Rotary systems, when operated as multiple units can supply a critical load of 50MVA.

Rotary UPS are often used in industrial or military applications.

A rotary UPS uses flywheels and/or batteries as an energy storage device which provides short-term energy to the critical load in the event of a power supply loss.

These devices also act as a buffer against power surges, spikes and dips. They are traditionally used in conjunction with stand-by diesel generators, where the storage device provides the back-up power for the brief time period required for the alternative supply to be brought on-line.

The rotary UPS is generally reserved for applications that require more than 200kVA of protection, for example high power requirements in industrial or military applications. Rotary UPS systems are normally extremely large and heavy systems which require routine maintenance.

Rotary systems are used where the power system being supported is large and the potential for faults is high, due to their robust construction.

**Example: Two rotary UPS units, both 500kW, providing critical energy supply support to an industrial process and critical IT infrastructure with a normal operational electrical load of 400kVA are selected from the ETL. The UPS units selected have an efficiency of 5% greater than a typical non-specified product. The potential annual savings are calculated as:**

- £28,220
- 253 MWh
- 89 tonnes CO<sub>2</sub>e

**With a typical additional capital cost of £40,000 (£200,000 non ETL capital cost) and lifetime energy and AIA benefits of nearly £300,000 at today's prices, the financial benefit of choosing an ETL listed product is over 7 times the additional cost. Furthermore with a potential AIA of £45,600 in year 1 plus additional energy savings, the extra capital cost is recovered within a year of purchase.**



# Rotary UPS

Rotary UPS systems are commonly combined with a back up diesel generator

Rotary UPS featuring flywheel,  
generator and diesel engine

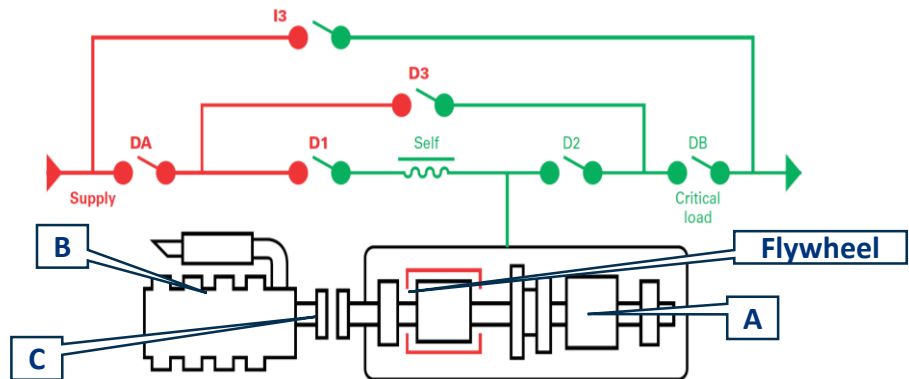

## Rotary UPS system

In the figure above, when mains supply is available breakers DA, D1, D2 and DB are closed feeding the critical load. The automatic bypass D3 is open.

The motor/generator (A) acts as a motor and drives a flywheel providing rotating energy storage. The motor/generator acts as an ideal power factor *correction* device and filters out minor transients in the supply.

If there are any micro breaks in supply, the flywheel can maintain the supply to the critical load. If there is a longer break in electrical supply, the input breaker D1 opens, the diesel engine starts (B), the clutch closes (C) and the critical supply is maintained through the generator all within seconds. There is a manual isolator (I3) that allows the unit to be bypassed.



# Hybrid Rotary UPS systems

Hybrid Rotary UPS systems are eligible for the ETL



## Hybrid Rotary UPS system

Hybrid rotary UPS systems use a combination of static systems, flywheels and motor generator technologies to provide a robust and high power UPS system.

These hybrid systems can be very efficient and provide high levels of security.

The figure on the right shows that when the supply from the utility network is good, the UPS operates by allowing the incoming electrical network to supply the critical load. In addition, a high efficiency motor/generator set is also online to provide supply back-up. If there is a short interruption or complete outage from the supply, the critical load is supported by a battery.

Systems of this type are eligible for the ETL.

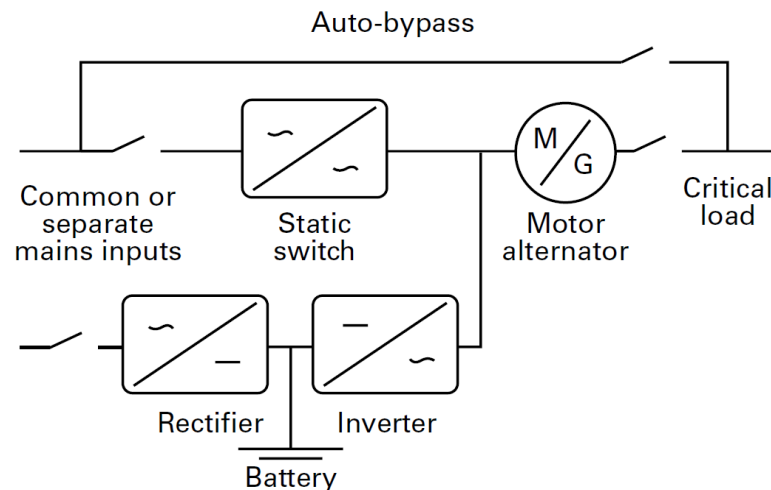



# UPS operating modes



There are three main modes of operation. ETL listed products must meet the ETL criteria when tested in their least efficient mode.

The VFI mode is the most common as it is the only true provider of power without interruption.

The VFI mode is the most appropriate for computer and data centre applications as it is independent of both variations in mains supply voltage and frequency.

1. **VFD (voltage and frequency dependent)** – commonly known as ‘off-line’, is a UPS where the mains power supplies the critical load directly during normal operation.
2. **VI (voltage independent)** – commonly known as ‘line interactive’, is a UPS similar to the off-line system except that it offers a higher performance by adding voltage regulation features in the by-pass system, often by installing a ‘buck-boost’ transformer.
3. **VFI (voltage and frequency independent)** - more commonly known as ‘on-line’ or ‘double conversion’. In this system, the output is always isolated from the input mains supply, and therefore any mains fluctuations or disturbances are only seen by the rectifier. The components of an on-line UPS are always active, and therefore need to be much more robust than those used for an off-line UPS which is only asked to provide output intermittently. Many systems now go beyond a single on-line system and provide parallel or redundant configurations. Often a UPS system is made up of a number of UPS units, connected in parallel.



# Parallel operation of UPS

## Parallel operation is used to enhance system reliability

In large businesses where reliability is of great importance, a single UPS can also be a single point of failure that can cause major disruption. To provide greater reliability, multiple smaller UPS units and batteries can be integrated together to provide redundant power protection equivalent to one very large UPS. Operating in this way is called an 'N+1' system.

The figure shows the efficiency of a UPS compared to the electrical load. As shown, the efficiency drops off at lower loads, leading to increased energy loss.

Higher efficiency UPS, such as those specified on the ETL, are designed to minimise the energy losses at all load levels.

For example, if two 200kVA UPS units were connected in parallel supplying a 200kVA load. Under normal operation they share the load equally at 100kVA each; However, if there is a problem with one UPS unit, it can be taken out of service for repair or maintenance while the other UPS is capable of supplying the load on its own.

Typical efficiency/load curves for transformer and transformer-less UPS systems\*

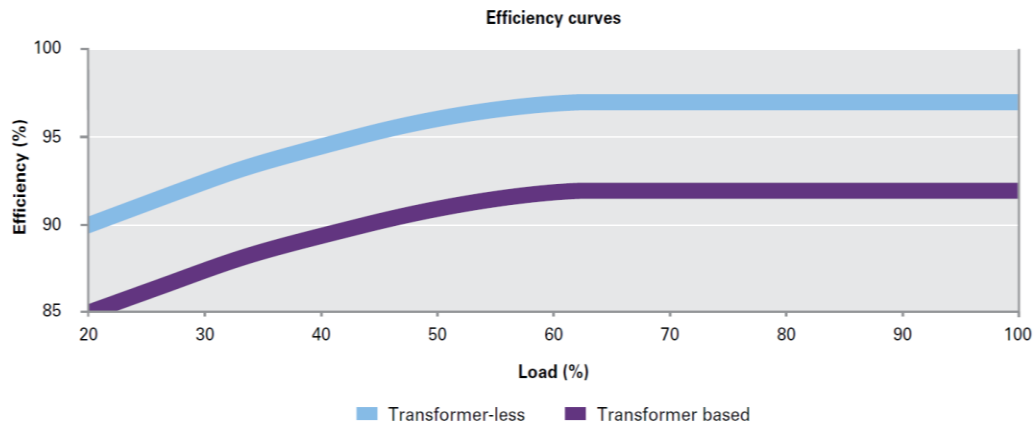

In operating an 'N+1' system, where if the load can be supplied by N units, the installation will contain N+1 units; failure of one unit will not impact on system operation.

In normal operation, each individual UPS unit operates at 50% load or less.

\* Source data: The Handbook Uninterruptible Power Supplies, Peter Bentley.



# Where can I find more information?



Energy Technology List



**For information about the ETL please visit:** <https://www.gov.uk/guidance/energy-technology-list> and see our Information for Purchasers factsheet: [https://assets.publishing.service.gov.uk/government/uploads/system/uploads/attachment\\_data/file/686850/Key\\_Information\\_for\\_Purchasers\\_Factsheet\\_February\\_2018.pdf](https://assets.publishing.service.gov.uk/government/uploads/system/uploads/attachment_data/file/686850/Key_Information_for_Purchasers_Factsheet_February_2018.pdf)



Or contact the ETL Help Line on 0300 330 0657; or email [ETLQuestions@carbontrust.com](mailto:ETLQuestions@carbontrust.com)

**To search for a product on the ETL please visit:**

[https://etl.beis.gov.uk/engetl/fox/live/ETL\\_PUBLIC\\_PRODUCT\\_SEARCH](https://etl.beis.gov.uk/engetl/fox/live/ETL_PUBLIC_PRODUCT_SEARCH)



© Crown copyright 2020

You may re-use this information (not including logos) free of charge in any format or medium, under the terms of the Open Government Licence.

To view this licence, visit [www.nationalarchives.gov.uk/doc/open-government-licence/](http://www.nationalarchives.gov.uk/doc/open-government-licence/) or write to the Information Policy Team, The National Archives, Kew, London TW9 4DU, or email: [psi@nationalarchives.gsi.gov.uk](mailto:psi@nationalarchives.gsi.gov.uk).