



Department for
Business, Energy
& Industrial Strategy



Energy Technology List

Boilers: hot water, biomass and steam

A guide to energy efficient equipment listed on the
Energy Technology List (ETL)



Contents

- 1. Introduction**
- 2. Setting the scene**
- 3. Benefits of purchasing ETL listed products**
- 4. Hot water boilers**
- 5. Biomass boilers**
- 6. Steam boilers**
- 7. Further information**



Introduction

Energy Technology List

The ETL is a government register of energy saving products. When you select products from the list you are choosing from amongst the most energy efficient products in the marketplace.

When replacing equipment, businesses are often tempted to opt for equipment with the lowest capital cost. However, such immediate cost savings may prove to be a false economy. Considering higher energy efficient products, means that life cycle costs are reduced, improving cash flow in the longer term.

Businesses can also claim accelerated tax relief through the Annual Investment Allowance (AIA) for investments in plant and machinery equipment. The AIA has been temporarily increased to £1 million from January 2019.

This leaflet illustrates the benefits of investing in energy saving boilers which qualifies for the ETL.

The ETL comprises two lists:

- **Energy Technology Criteria List:** defines the performance criteria that equipment must meet to qualify for the ETL;
- **Energy Technology Product List:** is the list of products that have been assessed as being compliant with ETL criteria.

Eligible boiler products on the ETL can be searched at:

https://etl.beis.gov.uk/engetl/fox/live/ETL_PUBLIC_PRODUCT_SEARCH



Setting the scene – hot water boilers

Definition

Hot water boilers are products that are specifically designed to heat water by means of a heat exchanger that transfers heat from combustion into the water as it passes through the product. Hot water boilers are used to produce hot water for space heating, process heating and domestic uses. They are available in a wide range of different designs and efficiencies. A typical hot water boiler has 11 components.

The ETL covers **four categories of products**:

- High temperature, high pressure, high efficiency hot water boilers with rated outputs greater than 400kW
- Low temperature, low pressure, high efficiency hot water boilers with rated outputs greater than 400kW
- Condensing hot water boilers with rated outputs greater than 70kW
- Condensing hot water boilers with rated outputs up to 70kW

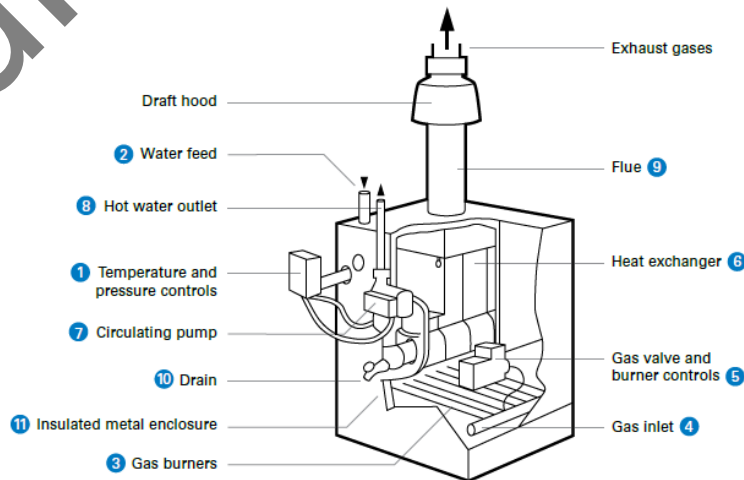



Setting the scene – biomass boilers

Definition

Biomass boilers are products that are specifically designed to burn solid biomass fuels (which include: logs, wood pellets and wood chips) in order to heat water, for process or space heating.

- Biomass boilers offer an alternative to fossil fuel boilers, in particular oil-fired boilers which are the main option for areas where mains gas is not available.
- Biomass is considered to be a renewable fuel. The savings that can be achieved broadly equate to the amount of CO₂ that would have been emitted if a fossil fuel-fired appliance had been installed.
- There are still savings when considering the upstream processes, ie. production and transportation of the biomass fuel, assuming the fuel is from a sustainable source.

Changing from LPG and oil-fired heating to wood fuel delivers CO₂ emissions savings of approximately 80% to 94%. Even when displacing natural gas, emission savings of between 73% and 90% are possible.



Setting the scene – steam boilers

Further information

For more information see the Carbon Trust's Steam and high temperature hot water boilers technology overview ([CTV018](#)).



Definition

Steam boilers are products that are specifically designed to convert water into pressurised steam by means of a burner that converts fuel into heat and a heat exchanger that transfers the heat into the water as it passes through the product.

- Steam boilers are used to produce steam for process heating, space heating and water heating. They consist of a burner, a pressure vessel containing a heat exchanger, and associated burner control systems and boiler control equipment.
- Steam boilers are available in a range of different designs and efficiencies. The ETL aims to encourage the purchase of the higher efficiency gas and oil fired steam boilers, including products that are designed to use liquid and gaseous biofuels.

Withdrawn



Setting the scene

Assumptions

ETL listed boilers must meet defined energy efficiency levels under various load conditions. In this document, the baseline scenario below has been used to calculate the potential financial (£), energy (kWh) and carbon savings (tonnes CO₂) unless otherwise indicated:

- Price for gas is 2.6p/kWh
- Carbon emissions for gas are 0.18416 kgCO₂/kWh
- Price for gas oil is 4.8p/kWh
- Carbon emissions for gas oil are 0.27588 kgCO₂/kWh
- Price for wood pellets is 4.5p/kWh
- Carbon emissions for wood pellets are 0.01270 kgCO₂/kWh
- ETL listed products are presumed to be in the top 25% of energy efficient products available in the marketplace

Energy cost and emissions data from BEIS 2017





Products on the Energy Technology List:

Hot Water Boilers

Hot water boilers

The efficiency of hot water boilers is primarily determined by the surface area, arrangement and materials of construction of the heat exchangers and the design and control of burners.

The Energy Technology List includes:

- **High temperature, high pressure, high efficiency hot water boilers with rated outputs greater than 400kW:**
Boilers designed to operate with a water pressure greater than 6 bar and/or outlet water temperature greater than 105°C, and that are not designed to recover latent heat from flue gases by condensing water vapour.
- **Low temperature, low pressure, high efficiency hot water boilers with rated outputs greater than 400kW:**
Boilers designed to operate with a water pressure up to and including 6 bar and/or an outlet water temperature up to and including 105°C that are not designed to recover latent heat from flue gases by condensing water vapour.
- **Condensing hot water boilers with rated outputs greater than 70kW:**
Boilers designed to recover latent heat from flue gas water vapour.
- **Condensing hot water boilers with rated outputs up to 70kW:**
Boilers designed to recover latent heat from flue gas water vapour



Products on the Energy Technology List: Hot Water Boilers

Hot water boilers

Eligible products have the following characteristics:

- They are gas and/or oil fired (where gas includes biogas and oil includes liquid biofuels).
- They automatically respond to changes in hot water demand by modulating their output in a continuous manner across a minimum specified turndown ratio, without initiating a purge cycle.
- Products with a rated output of up to 400kW are fitted with integrated burners.

Example: By installing an ETL compliant, gas-fired, condensing hot water boiler with an output of 200kW, as opposed to a new, non-ETL compliant model, the potential annual savings are calculated as:

- £951
- 36.8 MWh
- 6.74 tonnes CO₂

With a typical additional capital cost of £2,000, lifetime energy and ETL benefits could be around £10,200 at today's prices. With a potential ETL of approximately £1,824 and energy savings of £950 in year 1, the extra capital cost is recovered in less than 1 year of purchase.

Example capital cost of non-ETL compliant hot water boiler is £7,600. ETL compliant boiler example is £9,600. Efficiency of ETL compliant boiler is 93%. Assumes 5000 hours at 50% full load and 50% part load. 5% less efficient for non-ETL boiler.





Products on the Energy Technology List: Hot Water Boilers



Hot water boilers

The EU Ecodesign directive sets thresholds for minimum energy performance standards (MEPS) of hot water boilers. The MEPS are defined by seasonal space heating energy efficiency (SSHEE); the required efficiency values vary from between 75%-94% depending on the load and power rating of the boiler. The values of SSHEE also determine which energy efficiency class (ranging from G to A+++) the boiler belongs to.

The performance criteria for ETL eligibility is based on gross thermal efficiency values, for ETL listed products the efficiency values required vary from 83%-97% depending on fuel, size and boiler type.

Given the maturity of the hot water boiler technology and market there are often only incremental improvements in the technology, however disruptor technologies such as heat pumps offer an attractive alternative. Hybrid technologies incorporating the two types of heat generator are currently under development; currently no standards are available for this type of technology.



Products on the Energy Technology List: Biomass Boilers

Biomass boilers

Biomass boilers are used to heat water for process or space heating. Biomass boilers are available with a wide range of efficiencies. The ETL aims to encourage the purchase of products with the highest thermal efficiency. The fuels used in biomass boilers are renewable so their use will also reduce the amount of fossil fuel that might otherwise have been consumed.

Biomass boiler system equipment is based on established technologies for solid fossil fuels, which have been adapted to cope with the properties of biomass materials. The main types of product available use the following processes:

- Direct combustion of biomass – where sufficient air is supplied to the burning fuel to ensure complete combustion.
- Two-stage systems:
 - Stage 1 – the fuel is either gasified by reacting it with a limited amount of air (insufficient air is supplied to allow combustion, or CO₂ or steam is supplied instead of air); or pyrolysed by heating in the absence of air.
 - Both processes produce a fuel gas and solid char, and in Stage 2 both of these can be burned to release heat. The two-stage processes were originally developed for large scale solid fuel thermal plants, but the principles also appear in some biomass boiler designs.



Products on the Energy Technology List: Biomass Boilers



EcoDesign and Future Technologies

The Energy Related Products Directive, also known as EcoDesign, is to introduce new standards of efficiency that will apply to solid fuel fired biomass boilers of 500kW or less that provide space heating only.

For biomass boilers to comply they must meet requirements on seasonal space heating energy efficiency (75-77%) and must meet stringent targets on emissions of organic gaseous compounds, carbon monoxide, and nitrogen oxides.

Future technologies that aim to further improve the efficiency of biomass boilers include the introduction of condensing biomass boilers that could further increase efficiency by up to 12% and flue gas heat recovery systems that could recover up to 38% of the heat in the flue gas.



Products on the Energy Technology List: Biomass Boilers

Biomass boilers

Eligible biomass boilers must:

- be designed to burn wood, cereal straw, or solid fuels derived from them;
- heat water for process or space heating;
- meet the following air quality emission limits:
 - Particulate matter (PM) emissions must not exceed 30 grams per gigajoule (g/GJ) net heat input
 - Oxides of nitrogen (NOx) emissions must not exceed 150 grams per gigajoule (g/GJ) net heat input

Biomass boilers are typically eligible for subsidies under the renewable heat incentive (RHI), as such there has been a considerable increase in the number of biomass boilers being purchased.

Installing a wood pellet fired biomass boiler with an output of 180kW, running with a load factor of 25% and efficiency of 92%, as opposed to a new gas oil boiler offering the same energy output and 95% efficiency, the potential annual savings are:

- £1,375
- 0 kWh
- 112.8 tonnes CO₂

With a typical capital cost of £80,000, lifetime energy and ETL benefits could be around £18,900 at today's prices. With a potential ETL of approximately £15,200 and energy savings of £1,400 in year 1, the extra capital cost is recovered in less than 1 year of purchase.

Example capital cost of ETL compliant biomass boiler is £80,000; cost of similarly sized gas oil boiler is £65,600



Products on the Energy Technology List: Steam Boilers



Steam Boilers

Industrial steam boilers in the UK have a wide range of efficiencies from 80%-96% net at 100% load. ETL specified energy saving steam boilers have a minimum performance threshold efficiency of 92% net.

Fuel savings from an ETL steam boiler compared to a typical non-specified energy saving ETL steam boiler are around 7%. Fuel savings of between 2% and 5% can be achieved at part load conditions by fitting a modulating ETL burner rather than a basic two stage (hi/low) burner.

Eligible steam boilers:

- can be gas and/or oil fired;
- must use an appropriately matched forced draught burner;
- Shall automatically respond to changes in steam demand by modulating their output in a continuous manner across a minimum specified turndown ratio without initiating a purge cycle.

Installing an ETL compliant, gas-fired steam boiler with an output of 2MW, as opposed to a new similarly sized non-ETL compliant one offers potential annual savings of:

- £9,072
- 351 MWh
- 64.6 tonnes CO₂

With a typical capital cost of £110,100, lifetime energy and ETL benefits could be around £98,000 at today's prices. With a potential ETL of approximately £20,900 and energy savings of £9,100 in year 1, the capital cost is recovered in less than 1 year of purchase.

Example capital cost of non-ETL boiler is £91,000, and 5% less efficient.



Products on the Energy Technology List: Steam Boilers



Steam Boilers

Steam boilers can be used for a wide variety of applications, including but not restricted to: distributing heat, providing effective and safe humidification, achieving efficient sterilisation, using waste heat to provide chilled water.

This extensive range of applications results in steam boilers being integral to both industry and commerce, especially within the chemicals, food and drink, paper, refining and primary metal manufacturing sectors. Given the different scenarios steam boilers can be used in, they are therefore available in a variety of sizes, ranging from 3MW to greater than 70MW.

Fuel type	Turndown ratio	Test point MCR	Net thermal efficiency
Gas fired or dual fuelled	3.33:1	30%	≥ 92%
		100%	≥ 92%
Oil fired	2:1	50%	≥ 92%
		100%	≥ 92%



Where can I find more information?

Energy Technology List



For information about the ETL please visit: <https://www.gov.uk/guidance/energy-technology-list> and see our [Information for Purchasers](#) factsheet. Or contact the ETL Help Line on 0300 330 0657; email ETLQuestions@carbontrust.com



To search for a product on the ETL please visit: https://etl.beis.gov.uk/engetl/fox/live/ETL_PUBLIC_PRODUCT_SEARCH



This pack has been prepared by the Carbon Trust for BEIS. Whilst reasonable steps have been taken to ensure the information contained within this publication is correct, BEIS, the Carbon Trust, its agents, contractors and sub-contractors give no warranty and make no representation as to its accuracy and accept no liability for any errors or omissions.

© Crown copyright 2020

You may re-use this information (not including logos) free of charge in any format or medium, under the terms of the Open Government Licence.

To view this licence, visit www.nationalarchives.gov.uk/doc/open-government-licence/ or write to the Information Policy Team, The National Archives, Kew, London TW9 4DU, or email: psi@nationalarchives.gsi.gov.uk.