

**Pursuant to section 12 of
the Weights and Measures Act 1985
Certificate No 3102 Revision 1**

Issued by:

NMO

In accordance with the provisions of section 12 of the Weights and Measures Act 1985, the Secretary of State for Business Energy and Industrial Strategy has issued this UK national type-approval certificate to:

**Brookforce Ltd
5 Laurel Bank Close
Moneyreagh
Newtownards
BT23 6FD
United Kingdom**

And hereby certifies as suitable for use for trade the following pattern of a liquid measuring instrument for use in dispensing intoxicating liquor in fixed quantities of 25 ml.

The necessary data (principal characteristics, alterations, securing, functioning etc) for identification purposes and conditions (when applicable) are set out in the descriptive annex to this certificate.

Under the provisions of section 12(6) of the said Act, the validity of this certificate is limited as shown below.

Note: This certificate relates to the suitability of the equipment for use for trade only in respect of its metrological characteristics. It does not constitute or imply any guarantee as to the safety of the equipment in use for trade or otherwise.

Issue Date: 08 August 2020

Valid Until: 07 August 2028

Marek Bokota
Technical Manager
For and on behalf of the Head of Technical Services

CONTENTS

CERTIFICATION NO 3102

- 1 INTRODUCTION**
- 2 CONSTRUCTION**
 - 2.1 Mechanical
 - 2.2 Legends
 - 2.3 Sealing and stamping
- 3 OPERATION**
- 4 AUTHORISED ALTERNATIVES**
- 5 RECOMMENDED TESTS**
- 6 ILLUSTRATIONS**
- 7 CERTIFICATE HISTORY**

Descriptive Annex

1 INTRODUCTION

This approval covers a design of a hand-held liquid measuring instrument for use in dispensing intoxicating liquor in fixed quantities of 25 ml (Figure 1). The pattern consists of a transparent measuring chamber which depends upon the visibility through the sight glass to show clearly that the chamber is fully charged and discharged. The instrument is a bottle top pourer where the measuring chamber is supplied from a freestanding bottle connected to its inlet and dispenses one, when the operating arm is depressed onto the rim of the receiving container.

Due to the novel nature of the design the approval has a conditional validity of 2 years.

2 CONSTRUCTION

2.1 Mechanical (Figure 2)

2.1.1 Components

The instrument is constructed mainly in plastic with stainless steel springs and silicone rubber seals. The circular sight glass is moulded in transparent plastic. The head and sight glass are permanently bonded in place preventing adjustment or tampering once assembled.

The delivery tube is in four parts. The lower part is the operating arm (1) which is fitted to the spindle (2) which extends through the sight glass bowl (3) and is connected to the capacitor (4). The capacitor is fitted with a spring-loaded top valve assembly (5), which closes the inlet port during the dispensing operation.

The head (6) is provided with a positive sealing face for the capacitor disc valve assembly (7). The inlet tube, of the head, is fitted with a separator (8) which assists the flow from the bottle when the measuring chamber recharges.

The capacitor has a flat top surface beneath the valve assembly which actuates the air valve (9) to admit air into the bowl as the instrument discharges. The air valve is fitted with a return spring and washer.

The upper end of the delivery tube is recessed, above and below the cross bore, to accept two O-rings (10).

The delivery tube is returned to the closed position by a spring (11) acting between the spring collar (12) and the ferrule (13), the mechanism being enclosed by the ferrule.

The head assembly and bowl are ultrasonically welded together to form a tamperproof assembly.

2.2 Legends

2.2.1 The instrument shall bear the following legends:

- The capacity legend, 25 ml, which is durably marked on the sight glass. The characters are nominally 10 mm high.
- The manufacturer's name and certificate number are printed onto the headwork (Figure 3). Additional advertising may be fitted to the head assembly, which shall not obscure the sight glass in any way.

2.3 Sealing and stamping

2.3.1 The instrument is permanently bonded during manufacture to form a tamperproof, non-adjustable assembly. No further sealing is necessary. The verification mark is applied to a soft metal seal attached by a security wire, or nylon monofilament, affixed to the head assembly. The security seal shall be such that it cannot be removed without destroying the verification mark.

3 OPERATION

With the instrument fitted onto a bottle and inverted the instrument is fully charged with liquor. A downward force is then applied, and the operating lever makes contact with the rim of the receiving vessel. Further downward force is applied to initiate the dispense. As the delivery tube is raised the seal of the capacitor disc valve makes positive contact with the seating in the head thus preventing the ingress of further liquid. The O-ring of the dispense tube remains in the bore of the bowl at this stage. Further downward movement causes the flat top surface of the capacitor to open the air valve, and uncovers the cross bores allowing the liquid to discharge. Maximum movement is achieved when the top of the capacitor makes contact with the underside of the disc valve. The cross bores do not completely clear the bowl base in order to ensure complete discharge. On completion of dispense the instrument is raised and operating arm is released, the movement operates the above sequence in the reverse order. At no time will the inlet/outlet valves be open together.

4 AUTHORISED ALTERNATIVES

4.1 Having the stamp formed by an impact process directly onto the side face of the head assembly.

4.2 Having an alternative design for dispensing intoxicating liquor in fixed quantities of 35 ml (Figure 4).

5 RECOMMENDED TESTS

Due to increased surface tension it is possible that, on occasions, the instrument will not operate correctly when using water as the test liquid. Providing the instrument dispenses correctly, the dispensed quantity should be within statutory limits irrespective of the liquid used. If the dispense is not correct using water, then it must be tested with one of the prescribed spirits.

6 ILLUSTRATIONS

- Figure 1 25 ml measure
- Figure 2 25 ml measure sectional general assembly
- Figure 3 Position of Manufacturers Logo and Name and Certificate No
- Figure 4 35 ml measure

7 CERTIFICATE HISTORY

CERTIFICATE NUMBER	DATE	DESCRIPTION
3102	08 August 2018	Certificate first issued
3102 Revision 1	07 August 2020	Certificate validity extended to 10 years from the initial approval date. Address changed from: 38 Brooke Hall Heights Belfast Antrim, BT8 6WN United Kingdom



Figure 1 measure

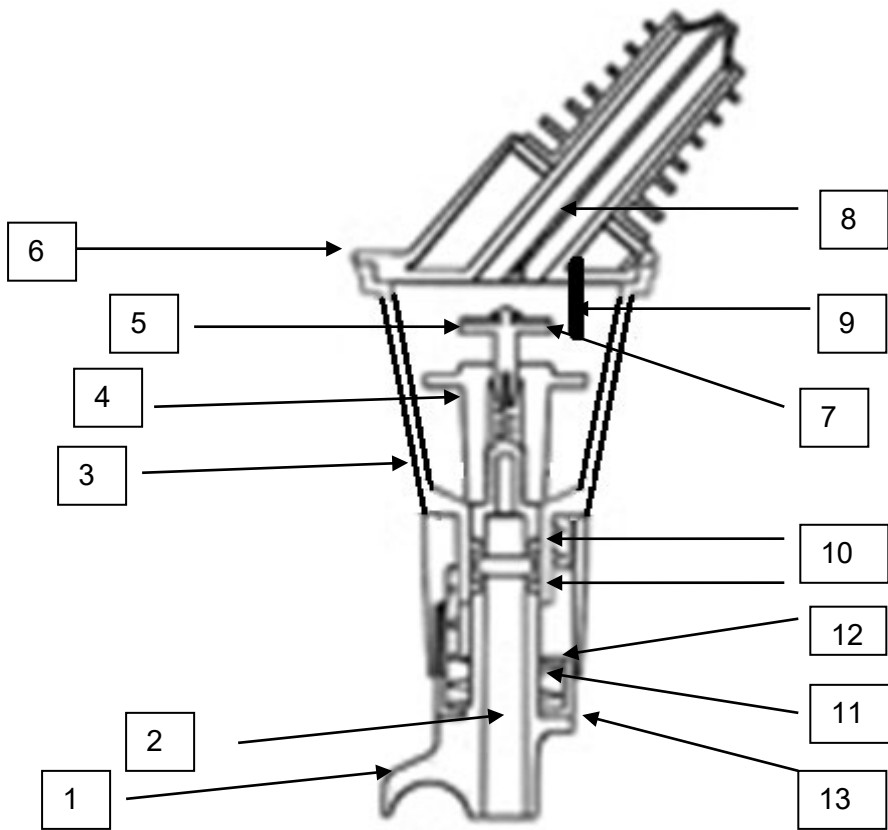

Figure 2 25 ml measure – Sectional general assembly

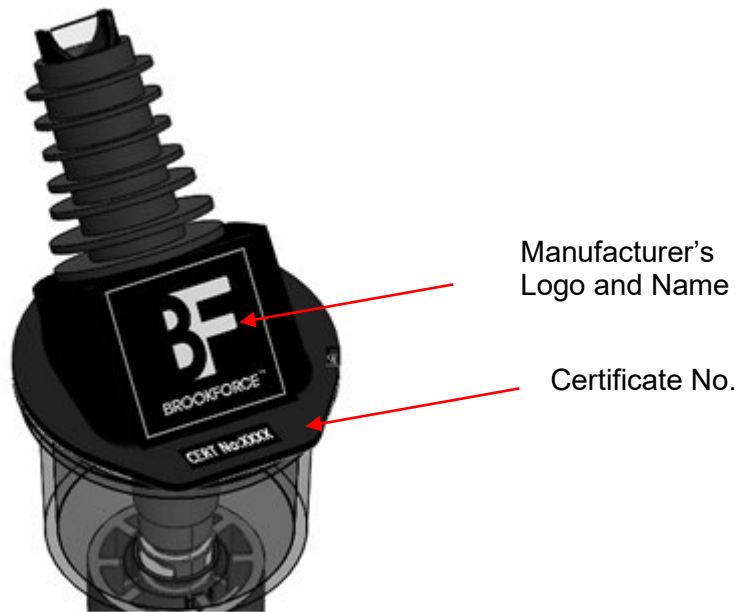

Figure 3 Position of Manufacturers Logo and Name and Certificate No



Figure 4 35 ml measure