

www.defra.gov.uk

Construction Code of Practice for the Sustainable Use of Soils on Construction Sites



BIS | Department for Business
Innovation & Skills

wrap

Material change for
a better environment

defra
Department for Environment
Food and Rural Affairs

Department for Environment, Food and Rural Affairs
Nobel House
17 Smith Square
London SW1P 3JR
Telephone: 020 7238 6000
Website: www.defra.gov.uk

© Crown copyright 2009

Copyright in the typographical arrangement and design rests with the Crown.

This publication (excluding the royal arms and departmental logos) may be reused free of charge in any format or medium provided that it is reused accurately and not used in a misleading context. The material must be acknowledged as crown copyright and the title of the publication specified.

Information about this publication and further copies are available from:

Defra
Soils Policy Team
3C Nobel House
London SW1P 3JR
Telephone: 020 7238 6419
Website: www.defra.gov.uk

This document is also available on the Defra website.
<http://defraweb/environment/land/soil/index.htm>

Published by the Department for Environment, Food and Rural Affairs.

Cover Image: Soils on Construction Sites, photo courtesy of the RSPCA.

PB13298

September 2009

Summary	2
About this Code	3
1 Introduction	4
1.1 Soil functions	4
1.2 Soil and construction	4
2 Related legislation	6
2.1 Waste legislation	6
2.2 Other legislation	9
3 Related guidance	10
4 Pre-construction planning	13
4.1 Knowing what soils are on site	13
Case Study 1: Amenity area of residential development	16
5 Soil management during construction	20
5.1 On-site soil management	20
Case Study 2: Comprehensive soil care for Channel Tunnel Rail Link	21
5.2 Topsoil stripping	23
5.3 Subsoil stripping	25
5.4 Soil stockpiling	27
Case Study 3: Poor gardens of housing development necessitate £90,000 of remedial work	30
6 Landscape, habitat or garden creation	33
6.1 Soil placement	33
Case Study 4: Decisions not to follow soil specifications cost company £25,000	37
6.2 Sourcing and importing topsoil	38
Case Study 5: Prestige residential development benefits from careful soil investigation and specification	42
6.3 Topsoil manufacture	44
Case Study 6: Cost saving of £400,000 on major brownfield site construction project	46
6.4 Soil aftercare	48
6.5 Uses for surplus topsoil	50
References	53
Glossary	55
Acknowledgements	58

Summary

Soil is a fundamental and ultimately finite resource that fulfils a number of functions and services for society which are central to sustainability. Some of the most significant impacts on this resource occur as a result of activities associated with construction activity, yet it appears that there is a general lack of awareness and understanding of this need within the construction industry.

A Code of Practice has therefore been developed to assist anyone involved in the construction sector to better protect the soil resources with which they work. By following the guidance in the Code you will not only be able to help protect and enhance the soil resources on site but you may also achieve cost savings for your business.

A summary of the key messages in this Code of Practice is set out below:

Pre-construction planning

- Have a soil resource survey carried out on site by a suitably qualified and experienced soil scientist or practitioner (e.g. a member of the Institute of Professional Soil Scientists – www.soilscientist.org) at the earliest convenience and prior to any earthworks operations.
- Incorporate the results of the soil resource survey into the site working strategy (e.g. Site Waste Management Plan or Material Management Plan) ensuring liaison between the soil resource survey and other ground investigations.
- Ensure that you are informed of and follow waste regulations as necessary.
- Consider the use of sustainable drainage systems on site as these can provide more long term protection of soils beyond the construction phase, by facilitating the infiltration and attenuation of surface water.

Soil management during construction

- Prepare a Soil Resource Plan showing the areas and type of topsoil and subsoil to be stripped, haul routes, the methods to be used, and the location, type and management of each soil stockpile.
- When stripping, stockpiling or placing soil, do so in the driest condition possible and use tracked equipment where possible to reduce compaction.
- Confine traffic movement to designated routes.
- Keep soil storage periods as short as possible.
- Clearly define stockpiles of different soil materials.

Landscape, habitat or garden creation

- Ensure that the entire soil profile is in a condition to promote sufficient aeration, drainage and root growth.
- Safeguard and utilise on-site soil resources where possible. If importing soils, use a reputable supplier, establish the source of the soil and ensure it is suitable for the intended use.

1. This Code of Practice for the sustainable use of soil on construction sites is a practical guide to assist anyone involved in the construction industry to protect the soil resources with which they work. It is particularly intended for use in England.
2. It contains guidance of interest to those involved at all stages of construction projects, from the developer, designer, contractor, sub-contractor (earthworks, landscape) and regulator.
3. Although the Code itself is not legislatively binding, by following it:
 - you will help protect and enhance the soil resources on site and achieve wider benefits for the environment;
 - you may achieve cost savings for your business;
 - it may help you to achieve your business sustainability targets; and
 - it may help you to meet legal obligations regarding waste controls.
4. The Code outlines current guidance and legislation concerning the use of soil in construction projects, before offering stage by stage guidance on the use, management and movement of soil on site.
5. The protection, use and movement of soil should be considered from the outset of a development project's planning, through its design and construction phases and on into future maintenance.
6. The Code provides guidance on the various stages of site development where soil should be considered and contains ten sections to provide practical advice on different aspects of using soil sustainably on construction sites:
 - i. Knowing what soils are on site
 - ii. On-site soil management
 - iii. Topsoil stripping
 - iv. Subsoil stripping
 - v. Soil stockpiling
 - vi. Soil placement
 - vii. Sourcing and importing topsoil
 - viii. Topsoil manufacture
 - ix. Soil aftercare
 - x. Uses for surplus topsoil
7. Each section explains the need for the advice and makes recommendations for good practice, including method statements, illustrations and a list of Do's and Don'ts.
8. The Code is complemented by Case Studies to demonstrate both good and poor practice, as well as a range of toolbox talks for use on site.

1.1 Soil functions

1. Soil is a vulnerable and essentially non-renewable resource. One hectare of topsoil, the most productive soil layer, can contain up to 5 tonnes of living organisms and because it can take more than 500 years to form a 2cm thickness, it is in practical terms non-renewable.
2. Soil fulfils a number of functions and services for society which are central to social, economic and environmental sustainability. These are:
 - food and fibre production;
 - environmental interaction (with water and air);
 - support of ecological habitats and biodiversity;
 - support for the landscape;
 - protection of cultural heritage;
 - providing raw materials; and
 - providing a platform for construction.
3. Soil also has a large social function, through providing the basis for greenspace, including gardens, playing fields and public open space. The latter provides cultural and social benefits that include increased well-being, physical and psychological health, and connection with nature. It consequently plays an important part in how people live.

1.2 Soil and construction

1. Some of the most significant impacts on soil properties occur as a result of activities associated with construction. Construction activity can have adverse impacts on soil in a number of ways by:
 - covering soil with impermeable materials, effectively sealing it and resulting in significant detrimental impacts on soils' physical, chemical and biological properties, including drainage characteristics;
 - contaminating soil as a result of accidental spillage or the use of chemicals;
 - over-compacting soil through the use of heavy machinery or the storage of construction materials;
 - reducing soil quality, for example by mixing topsoil with subsoil; and
 - wasting soil by mixing it with construction waste or contaminated materials, which then have to be treated before reuse or even disposed of at landfill as a last resort.
2. Although planning approval is a pre-requisite to all development proposals and consideration of the impact on soil is an integral part of the environmental assessment process, there is no specific direct planning control on the sustainable use and management of soil resources on construction sites or a requirement for the monitoring of soil protection and sustainable reuse.

3. The guidance provided in this Code will help achieve good soil management at all stages of the construction process.
4. In addition to this Code, you should also consider the use of sustainable drainage systems on site as these can provide more long term protection of soils beyond the construction phase, by facilitating the infiltration and attenuation of surface water. Features such as permeable surfaces reduce soil sealing and help to increase water infiltration and can increase groundwater recharge, while swales and retention basins can temporarily collect surface water and reduce soil erosion from surface water runoff.

2.1 Waste legislation

1. The sustainable use of soil on construction sites is influenced by EU legislation related to waste, national recycling objectives and incentives, and UK regulation on waste.

Waste or not waste?

2. The construction industry is the largest single source of waste arisings in England, producing 90 million tonnes of inert waste annually, some of it soil. Protection and reuse of soil is fundamental to initiatives to reduce such waste.
3. Essential to the reuse of soil from construction sites or redevelopment projects is the initial determination of whether the material in question is regarded as waste within the legal definition of the term.
4. There is no definitive list of what is and is not waste. In determining whether surplus soil is or is not a waste, a number of tests have to be used to determine whether the material is being, is required to be, or is intended to be, discarded.
5. The *Definition of Waste: Development Industry Code of Practice* (DoWDICoP) is a voluntary Code launched in September 2008 (applicable to England and Wales) that was initiated to provide a clear and concise process to determine whether excavated materials on a development site constitute waste in the first instance, and to identify the point when treated waste can no longer be considered as waste. **This Code of Practice is no substitute for obtaining independent legal advice or for consulting the Environment Agency. Decisions on the definition of waste must be made in the light of all the specific circumstances of an operation or activity and in accordance with the current case law.**
6. There may be a certain degree of support between this *Code of Practice for the Sustainable Use of Soils on Construction Sites* and the DoWDICoP, particularly when compiling a Materials Management Plan and a Soil Resource Plan. There is however a clear distinction between the two Codes. The *Code of Practice for the Sustainable Use of Soils on Construction Sites* is to be used to protect soils and ensure adequate soil function (e.g. plant growth, water attenuation, biodiversity) during and after construction. The DoWDICoP is to be used to help determine whether materials on construction sites are classified as waste or not.

Strategic objectives

7. Central government objectives for waste management are outlined in the *Waste Strategy for England 2007* (Defra, 2007). Government is seeking to avoid the disposal of soil to landfill through recycling incentives and less onerous regulation of low-risk waste processes. A key target is to increase diversion of non-municipal waste (including soil) from landfill and to secure better integration of treatment processes with the aim of reducing waste by making products with fewer natural resources and a greater proportion of recycled components.
8. The reuse of soil is an important factor in the Waste Strategy and will consequently contribute to breaking the link between economic growth and waste growth with the dual benefits of reduced environmental impact and the preservation of natural resources.

Regulation

9. The Environment Agency is responsible for enforcing waste management legislation in England and Wales (Scottish Environment Protection Agency in Scotland) and regulation is discharged under the terms of the EU Waste Framework Directive. It is normally an offence to undertake waste disposal or recovery operations without being in possession of a Waste Framework Directive permit which in England and Wales is an Environmental Permit (Environmental Permitting (England and Wales) Regulations 2007).
10. Environmental Permits are designed to regulate higher risk activities that are defined either in terms of the waste types they accept, the volumes of waste they treat, or the complexity of the process itself.
11. Permits are more complex to apply for and operate than to register an exemption. They require an annual subsistence charge proportional to the degree of risk the process presents, are closely monitored during physical inspections by the Environment Agency to ensure compliance, and require the presence of an appropriately qualified 'Technically Competent Manager' in order to continue in operation.
12. There are a number of exemptions from Environmental Permitting prescribed in Schedule 3 to the Environmental Permitting (England and Wales) Regulations 2007. These exemptions range from small-scale storage to large construction projects involving the recovery of large quantities of waste. Exempt waste operations are subject to certain limitations and include the permitted types and quantities of waste, the methods of disposal or recovery and pollution control measures.
13. These exemptions are intended to provide a "lighter touch" form of regulation than an Environmental Permit and need to be registered with the Environment Agency. They have been developed to encourage reuse or recycling of low-risk materials in a controlled manner without causing pollution of the environment or harm to human health.
14. The exemptions from Environmental Permitting are currently being reviewed. More information can be found on the Defra website¹. Development sites should contact the Environment Agency to confirm which Permit(s) or exemption(s) may be required for each specific development.
15. The Site Waste Management Plans Regulations 2008 came into force in England in April 2008 for all construction projects with a project cost exceeding £300k. They aim to reduce the amount of waste produced on construction sites and prevent fly-tipping. Amongst other requirements, the Site Waste Management Plan (SWMP) must:
 1. describe each waste type expected to be produced in the course of the project;
 2. estimate the quantity of each different waste type expected to be produced;
 3. identify the waste management action proposed for each different waste type, including re-using, recycling, recovery and disposal.

¹ <http://www.defra.gov.uk/environment/waste/management/exemptions/index.htm>

Related legislation

Recycling incentives

16. The Finance Act 1996 introduced the concept of Landfill Tax for “taxable disposals” of waste in landfill sites. There are two tax rates. The lower rate, for inactive materials (including soil), is currently £2.50 per tonne. This tax coupled with the cost of transport to landfill combine to represent a reasonable incentive to recycle soil.
17. The *Definition of Waste: Development Industry Code of Practice* (DoWDICoP) includes the development of a Materials Management Plan to ensure that developers, architects, engineers and contractors consider the issues surrounding waste legislation that may affect the reuse or recovery for all materials that will be encountered during a construction project. DoWDICoP may also be of assistance in preparing SWMP for construction projects, subject to the requirements of the Site Waste Management Plans Regulations 2008.

Plans

18. The diagram below sets out the hierarchal relationship of Site Waste Management Plans, Materials Management Plans and Soil Resource Plans (see Section 5.1).

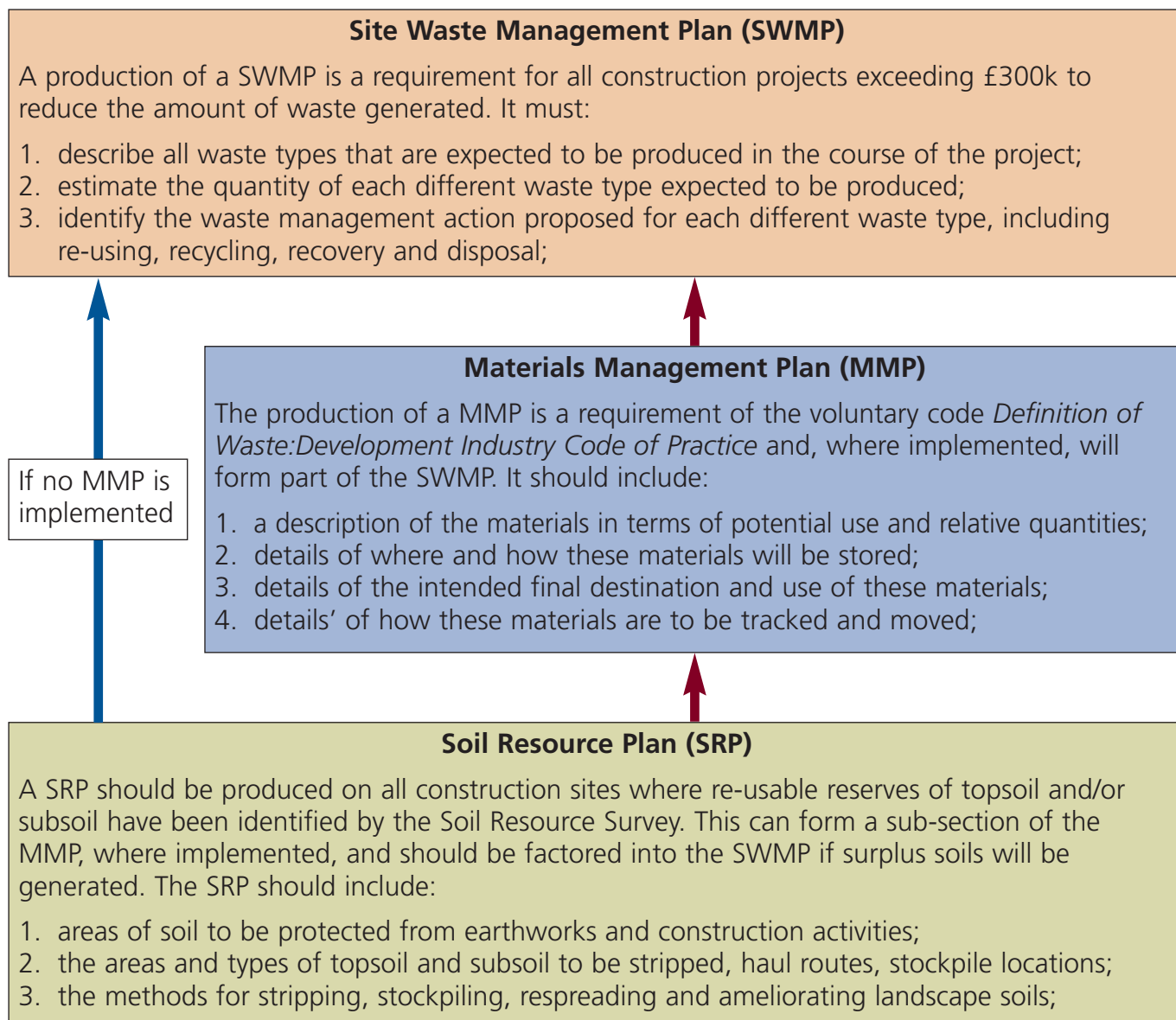

2.2 Other legislation

1. There is a range of additional legislation that is associated with soil on construction sites, including:
 - i. Agricultural Land (Removal of Surface Soil) Act 1953 – this places restrictions on the removal of surface soil from agricultural land without planning permission.
 - ii. Clean Neighbourhoods and Environment Act 2005 – deals with problems affecting the quality of the local environment, including (amongst other things) waste. Section 5 of the act makes provision about the registration of carriers of particular kinds of waste, the illegal deposit of waste (fly tipping) and the powers of local authorities to collect and dispose of waste. This section also makes provision for dealing with waste at construction sites.
 - iii. Environmental Liability Directive 2004 – this imposes obligations on operators of activities which cause or threaten to cause environmental damage to ensure the remediation of damage to (amongst other things) soil, through the restoration of the environment to its baseline condition.
 - iv. Environmental Protection Act 1990 – this includes Part IIA on Contaminated Land which requires local authorities to identify contaminated land which poses a risk of harm significant to human health and the wider environment.
 - v. Groundwater Regulations 1998 – to ensure proper control over the use and disposal of substances on land which could directly or indirectly pollute groundwater. These are categorised as List I and List II substances.
 - vi. Town and Country Planning Act 1990 – this promotes the reclamation and reuse of derelict and contaminated land, including the reuse and management of soil on development sites.
 - vii. Water Resources Act 1991 – this contains the primary provisions relating to the pollution of controlled waters, applicable to soil on construction sites where operations result in erosion and runoff into a local watercourse.

Related guidance

1. Although there is various existing guidance on the care and use of soil for supporting the soft landscaping of construction projects, there is no overarching guidance on soil use and management at each stage of the construction process. The main items of related guidance are outlined below; these have been considered in the development of this Code:

British Standard code of practice for general landscape operations (excluding hard surfaces) (BS4428: 1989)

2. The *Code of practice for general landscape operations* (BS4428: 1989) contains recommendations for the following general landscape operations: preliminary investigations (including soil), land drainage, grading and cultivation, seeding of grass areas, turfing, amenity tree and woodland planting, and planting of shrubs, herbaceous plants and bulbs. More specialist amenity areas, such as sports playing fields, bowling greens, and golf courses are not covered by the Standard.
3. Although the Standard is often cross-referenced within specifications, it has in effect been superseded by more recent publications such as *National Building Specification Landscape* (outlined below) and landscape architects' own specifications.

British Standard specification for topsoil and requirements for use (BS3882: 2007)

4. The *British Standard Specification for topsoil* (BS3882: 2007) specifies the requirements for topsoils (natural or manufactured) that are moved or traded. It contains one main grade (multipurpose topsoil), which is suitable for the majority of needs, though specific-purpose topsoils have also been identified for specialist applications. The Standard also includes a section on the use and handling of topsoil. It is not intended (or appropriate) for the grading, classification or standardisation of in situ topsoil or subsoil.

British Standard Trees in relation to construction. Recommendations (BS5837: 2005)

5. The British Standard document, *Trees in relation to construction*, gives recommendations and guidance on the principles to achieve a satisfactory juxtaposition of trees (including shrubs, hedges and hedgerows) with structures. It provides guidance on how to decide which trees are appropriate for retention, on the means of protecting these trees during development, including demolition and construction work, and on the means of incorporating trees into the developed landscape.

Environment Agency advice

6. The Environment Agency provides a range of online advice for construction and building trades (see NetRegs website²) including a section on soil and soil stripping and a section on dealing with contaminated land.
7. The Environment Agency's *A guide for developers* (2006) provides practical advice on making developments better for people and the environment. Although references to soil are limited in this guide, it recognises the need to protect soil for its environmental and financial value.

Good practice guide for handling soils (MAFF, 2000)

8. The aim of the Ministry of Agriculture, Fisheries and Food's *Good practice guide for handling soils* is to provide comprehensive advice on soil handling to operators, soil moving contractors, consultants and planning authorities dealing with soil handling and

2 Available at: <http://www.netregs.gov.uk>

management on mineral extraction and waste sites. The guide is in the form of 19 Sheets, each providing detailed information on best practice methods for soil stripping, soil stockpiling, excavation from storage mounds, soil replacement, de-compaction and cultivation using different machinery combinations.

Guidance for successful reclamation of mineral and waste sites (Defra, 2004)

9. The Defra *Guidance for successful reclamation of mineral and waste sites* complements the MAFF *Good practice guide for handling soils*. It provides checklists and further guidance on soil use and handling, but is largely aimed at helping local government consider the adequacy of planning applications, restoration proposals and aftercare provisions for quarries and landfills.

Manual of contract documents for highway works: Volume 1 Specification for highway works (Highways Agency, 1998 plus a series of amendments 1998-2007)

10. The Highways Agency's *Specification for Highway Works* is used during the construction of new roads as well as the improvement or reconstruction of existing roads and bridges. It also covers such schemes as the installation of road lighting and traffic signals or other traffic signing schemes on existing highways. The Specification is divided into Series which cover a wide range of subjects in detail, such as site clearance, fencing, drainage, earthworks, pavement design, traffic signs, structures, electrical work, landscape and ecology.
11. Series 600 Earthworks and Series 3000 Landscape and Ecology deal with issues relating to the use and management of soil on highway schemes. These include: topsoil stripping methods, stockpiling methods and heights, subsoil preparation, depths of respread topsoil, treatments to topsoil, soil handling restrictions, seeding and planting and the management of landscape habitats.

National Building Specification Landscape (updated 2007)

12. *National Building Specification Landscape* provides specifiers, such as landscape architects, the ability to create up-to-date specifications and preliminaries for both hard and soft landscape projects. The specification is sub-divided into a number of sections but reference to soil is limited. The most relevant specifications for use of clean soils are in D20 (Excavating and filling) and Q28 (Topsoil and growing media).

Strategy for sustainable construction

13. A joint industry/Government *Strategy for Sustainable Construction* was launched on 11 June 2008. It lays out actions and deliverables relating to the key aspects of sustainability including the area of waste, and indicates that Defra and others will be looking at ways in which waste can be further reduced. Developing and rolling out tools, and improving our knowledge base, are important aspects of the future work indicated in the Strategy.

Sustainable drainage systems

14. The *Building Regulations Approved Document H* provides guidance on the incorporation of sustainable urban drainage systems (SUDS) and sets out a hierarchy of drainage options, with an adequate soakaway or other infiltration system being the preferred option.
15. Communities and Local Government have also strengthened the planning context for SUDS through *Planning Policy Statement 25: Development and Flood Risk*.

Related guidance

16. Detailed guidance on SUDS design, construction, operation and maintenance can be found in CIRIA publications C609 (Sustainable drainage systems – hydraulic, structural and water quality advice), C697 (The SUDS manual) and C698 (Site handbook for the construction of SUDS).

The Definition of Waste: Development Industry Code of Practice (DoWDICoP)

17. DoWDICoP was initiated to provide a clear and concise process to determine whether excavated materials on a development site constitute waste in the first instance, and to identify the point when treated waste can no longer be considered as waste. It applies to both uncontaminated and contaminated material from anthropogenic and natural sources (including topsoil and subsoil) excavated:
 - for use on the site from which it has been excavated, either without treatment or after on-site treatment, in the development of land;
 - for use in the development of land other than the site from which the material has been excavated, following treatment at an authorised treatment facility, e.g. Hub site within a defined Cluster project and used in the development of land.
18. **Principles for the Use of Materials as Non-Waste**

The DoWDICoP indicates that there is no single factor that can be used to determine if something is a waste or when it ceases to be waste. In the context of excavated materials used on sites undergoing development, the DoWDICoP discusses the following factors to be of particular relevance:

 - Factor 1: Suitability for use without any further treatment
 - Factor 2: Certainty of use
 - Factor 3: Quantity of material
19. In order to demonstrate that the above factors are satisfied, the DoWDICoP requires a Materials Management Plan (MMP). The MMP should form part of a Remediation Strategy or Design Statement, which has been derived using an appropriate risk assessment. It is anticipated that the MMP will also form part of the SWMP for a development site. In summary, the MMP provides:
 - a description of the materials in terms of potential use and relative quantities of each category underpinned by an appropriate risk assessment;
 - details of where and, if possible, how these materials will be stored;
 - details of the intended final destination and use of these materials;
 - details of how these materials are to be tracked;
 - contingency arrangements that must be put in place prior to movement of these materials.

4.1 Knowing what soils are on site

Why?

1. Inadequate identification of clean soil resources not only risks good soil becoming mixed with spoil or contaminated materials, thereby restricting or preventing its reuse, but it will also result in the need to import soil for landscape works. This will inevitably increase the cost of the project.
2. Identification of topsoil and subsoil resources is also necessary as part of a construction site's Site Waste Management Plan or Materials Management Plan) as most greenfield developments generate surpluses of topsoil. This normally has to be exported from site.

How?

3. A soil resource survey, separate from a geotechnical or geoenvironmental survey, should be carried out on the site at the earliest convenience by a suitably qualified and experienced soil scientist or practitioner (www.soilscientist.org) and prior to any earthworks operations.

The Survey...

... will on most sites be carried out by a soil scientist using hand-operated soil sampling equipment, though some trial pits might be needed in order to investigate soil layers inaccessible by hand auger or the contents of stockpiles (if any are present on the site). The primary investigation should be based on a rectilinear or herringbone grid-based pattern with the characteristics of each soil layer (colour, texture, drainage characteristics and whether topsoil or subsoil) recorded. It can be combined with a geotechnical or geo-environmental survey provided that the relevant expertise is applied.

On large greenfield sites there should be at least one investigation every 10,000m² (1ha). On small greenfield sites or brownfield sites there should be at least one investigation every 5,000m² with a minimum of 10 locations investigated (further reference from BS3882:2007, BS5930:1999, BS10175:2001).

4. This needs to be co-ordinated with other site assessment surveys (e.g. contamination, ecology, archaeology, arboriculture, invasive weeds) to take into account any specific requirements of sites of designated environmental, ecological and archaeological interest. The survey should provide the necessary information to delineate, quantify and characterise the topsoils and subsoils of a site prior to these materials being excavated for reuse on or off-site.
5. The survey should include appropriate analysis of representative soil samples to adequately characterise the different soil materials (e.g. pH, salinity, particle size analysis, nutrients, organic matter, potential contaminants). The survey may be linked to, or draw on information in, a land classification survey that may have been carried out as part of the planning application process.

Pre-construction planning

6. The results of the survey and analysis should be presented in an interpretive report that includes maps showing the location and extent of soil contrasting in any of the following parameters – texture, stoniness, organic matter content, compaction or permeability. The report should:
- include a description of the characteristics of each soil resource;
 - discuss the suitability of the different soil materials for reuse; and,
 - make recommendations for the handling and storage of the identified soil materials in order to protect soil functions during site working.

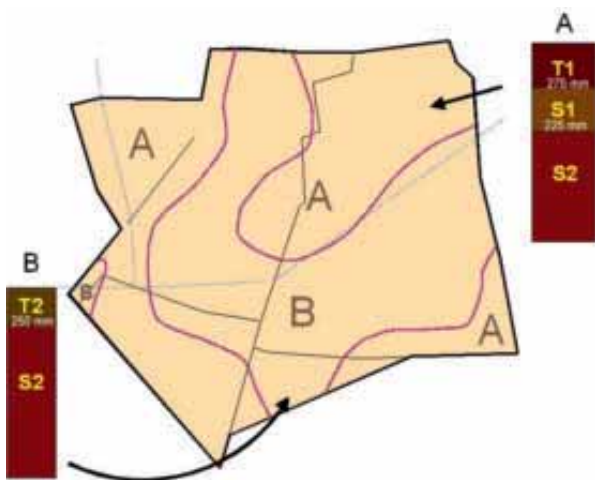

Soil resources map, showing thicknesses of different topsoil resources (T1 & T2) and a good quality subsoil resource (S1).



Topsoil map of a proposed development site, showing variation in thickness (cm).

Samples...

... of any potentially re-usable soil resources should be taken, submitted to an appropriate UKAS/MCERTS accredited laboratory and analysed according to BS3882:2007, with soil materials of contrasting nature separately sampled and analysed. To ensure accurate representation of each sampling area, several incremental samples should be taken across it and mixed together to create one composite sample (minimum 2kg) for analysis. Sampling patterns based on a rectilinear grid or a random 'figure of W' are equally suitable.

If soil stockpiles are present, point samples should be taken at regular intervals from both the surface 1m and the core. One composite sample (minimum 2kg) should represent no more than 5,000m³ of soil.

7. Further interpretations possible as site planning progresses and the landscape scheme is designed include:
- preparation of a soil budget, including identification of any surpluses or deficiencies and storage requirements; and,
 - recommendations on how to improve the soil for the expected landscape use or habitat creation.

8. If soil resources surplus to requirement are identified these should be highlighted for inclusion within the MMP (as part of the SWMP) to establish sustainable off-site uses for the soil.



Do

- ✓ Undertake the soil resource survey before any earthmoving operations start.
- ✓ Ensure that the survey is carried out by suitably qualified and experienced soil scientist or practitioner.
- ✓ Ensure co-ordination between the soil resource survey and other ground investigations as each might have information useful to the other.
- ✓ Incorporate the results into the Material Management Plan or the Site Waste Management Plan.

Don't

- ✗ Rely on a geotechnical survey or contamination survey for detailed information on topsoil or subsoil resources.

Case Study 1: Amenity area of residential development

1. This area formed the final phase of a 2.7ha residential development that had been constructed between 2003 and 2006. The 950m² area had been occupied by site offices and equipment storage facilities over the construction period but, under the planning permission, was required to be reinstated to a condition suitable for creation of a children's play area with a financial contribution by the developer (a major UK housebuilder) for this and other local play provision.



Development layout with amenity area circled

Site preparation

2. Clearance of the site yard commenced in January 2007 with a requirement by the local authority for operations to be completed by the end of the month. The agreed specification for site preparation use was to strip existing materials (which were a mixture of soil and aggregate) to a depth of 300mm, remove to landfill and replace with clean soil. There was no investigation as to whether removal of this amount of material from the whole area was necessary, though there was one small area affected by a diesel spillage and which needed deeper removal of soil.
3. Stripping started on 16 January 2007 (Photo 5.1.1) by 360° excavator with lorries regularly arriving to take the excavated material to landfill. The weather in early January had been very mild and unsettled and, although rainfall for the month was near average, almost every day until work started had been wet.
4. Deliveries of topsoil started on 24 January, the morning after a brief cold spell had produced about 20mm of snow cover. The first tipper lorries delivering topsoil arrived as day broke, reversed onto the snow-covered wet subsoil and immediately became bogged down (Photo 5.1.2), creating deep ruts. Topsoil was tipped onto these (Photo 5.1.3) and spread out. Work progressed for several days with the exposed subsoil becoming progressively compacted over a large V-shaped area (Photo 5.1.4) as 35 lorries reversed over the subsoil to tip their load. The excavator driver, acknowledging that conditions were bad for soil handling, asked the developer's supervising representative whether they wanted the soil 'sprinkling' over the site or 'tracking down'. The request was for the land to be tracked down flat. It was pointed out to the developer's supervising representative that the

compaction created in the soil would cause ongoing drainage problems. He considered that this was relatively unimportant as it would only affect 'about a quarter of the site'. Tipping soil on the edge and moving it into place using the excavator had been considered but would take too long with the machinery hired in.

5. The soiling work was completed in three days and, during long periods of potential inactivity between deliveries of topsoil, the excavator driver repeatedly drove up and down the placed topsoil to try and level every minor undulation, thus causing additional compaction and leaving the surface prone to ponding after subsequent wet days (Photo 5.1.5).
6. There was little activity on the land for some weeks until contractors arrived to complete the site roads and stored paving materials and a small excavator on the edge of the area (Photo 5.1.5). These remained until roads and pavements were completed in mid-May but left a small area of soil contaminated with aggregate and brick which was removed from the site before a delivery of pebbly topsoil and final levelling of the site was undertaken on 1 June (Photo 5.1.6). After rain had made the stone content of the latest soil additions more evident, the site was hand raked and stone-picked before being handed over to the local authority.

Play area

7. Creation of the play area commenced on 12 June 2007 with delivery of storage containers and equipment. By 14 June torrential rain fell as a slow moving low pressure system brought storms to most of the country. By the morning of 15 June the site was saturated and draining only slowly because of the compacted soil, but machine digging of bases for the play equipment started. The result is illustrated by Photo 5.1.7. A further attempt at site work was made the following week, with similar results, so work was suspended and remained so during the extremely wet spell that characterised the following 10 days. Despite a somewhat drier July, surface water remained on the site for some weeks delaying recommencement of work until the end of the month. Works were eventually completed in mid September 2007.
8. Early indications are that water is ponding after minor rainfall and the expectation is that such drainage problems will continue.

Pre-construction planning



5.1.1



5.1.2



5.1.3



5.1.4



5.1.5



5.1.6



5.1.7

Photographic record of site operations (from top left, moving across then down the page)

- 5.1.1 Clearance of site yard with hydraulic excavator removing upper 300mm of ground.
- 5.1.2 First delivery of topsoil with hydraulic excavator assisting bogged down delivery lorry.
- 5.1.3 Newly tipped topsoil being spread over snow, and ruts created by delivery lorries.
- 5.1.4 Large area of compacted subsoil created by delivery lorries reversing over the ground.
- 5.1.5 Paving materials stored on edge and surface ponding on compacted soil surface.
- 5.1.6 Additional levelling and topsoil spreading.
- 5.1.7 Creation of play equipment bases after heavy overnight rain.

Lessons learnt

- Insistence by the local authority that work should be completed in the winter (when installation of play equipment was not expected until summer) caused an unnecessary risk of soil damage.
- Given the situation imposed upon them, the developers should have adopted better work practices. Lorries returning from taking excavated spoil to landfill should have been used to bring in topsoil and could have then reversed onto ground still to be stripped in order to tip the soil on to the newly exposed subsoil. The excavator could then have pushed out the tipped topsoil to finished levels. This would have avoided all vehicle movements on soils. Final levelling and addition of any extra topsoil should then have been deferred until dry weather.
- Once an area is reinstated with soils it should not be used for storage of building materials but considered a 'no-go' area for all except landscape operations.
- There needs to be sufficient flexibility in site works to allow planned mechanised operations to be deferred if preceding weather conditions create unsuitable ground conditions.

Savings that could have been made

- Investigating what soil need to be removed instead of stripping the whole area to a depth of 300mm could have saved up to £5,000-£10,000.
- Using an improved work method that made better use of return loads could have saved the developer a portion of the transport costs.
- Avoiding compaction could potentially save the developer several thousand pounds if required to subsequently carry out remedial drainage work.
- Preventing the use of all parts of the newly soiled area for subsequent construction-related activities would have saved the £1,500 cost of removing stone contaminated soil and importing replacement topsoil.

5.1 On-site soil management

Why?

1. Careful management of topsoil and subsoil is an important aspect of sustainable use of materials that are being stripped, whether for sale off-site or for retaining on-site for later landscape preparation. Without a proper Soil Resource Plan there is the risk of losing, damaging or contaminating valuable soil resources.

How?

2. For all but the smallest of sites where re-usable reserves of topsoil and/or subsoil have been identified, a Soil Resource Plan should be prepared as a defined sub-section to a MMP and may be factored into the SWMP. This should show the areas and type of topsoil to be stripped, haul routes, the location of each soil stockpile and the type of soil to be stored within it. If the site has insufficient room to stockpile soil it may be more appropriate to find a sustainable off-site use for the temporary surpluses and then import suitable soil later.

Soil Resource Plan

A Soil Resource Plan will normally form part of the Materials Management Plan (and may be factored in to the Site Waste Management Plan) for the site.

It should include the following:

- maps showing topsoil and subsoil types, and the areas to be stripped and left in-situ.
- methods for stripping, stockpiling, respreading and ameliorating the soils.
- location of soil stockpiles and content (e.g. Topsoil type A, subsoil type B).
- schedules of volumes for each material.
- expected after-use for each soil whether topsoil to be used on site, used or sold off site, or subsoil to be retained for landscape areas, used as structural fill or for topsoil manufacture.
- identification of person responsible for supervising soil management.

A Soil Resource Plan should not be so complicated that it is unworkable in practice.

3. Areas of soil to be protected from construction activities (e.g. retained trees, protected habitats, archaeology, invasive weeds) should be clearly marked out by barrier tape and exclusion signs. Haul routes should be no wider than necessary to accommodate two passing vehicles and should be stripped of soil down to a firm base. Indiscriminate vehicle movements across soil should be avoided.
4. Changes to the Soil Resource Plan, such as changed haul routes or different than intended stockpiling locations, should be clearly marked on plans readily accessible by relevant site personnel.

Soil management during construction

Do

- ✓ Clearly define soil types, areas of soil to be stripped, haul routes and stockpile locations on your Soil Resource Plan.

Don't

- ✗ Create haphazard stockpiles of soil on site.

Case Study 2: Comprehensive soil care for Channel Tunnel Rail Link

1. The Channel Tunnel Rail Link (CTRL) was the first major new railway to be constructed in the UK for over a century and the first high-speed railway. Section 1 runs for 74km from the Channel Tunnel through the county of Kent and joined the existing railway network on the outskirts of London. Section 2, completed in late 2007, links to Section 1 and continues the route to St. Pancras Station.
2. The route of Section 1 was almost entirely through agricultural land (with some woodland) and involved the disturbance of soil, not only permanently along the 175ha now occupied by the line, but also on 675ha temporarily used for construction compounds, mitigation earthworks, cut and cover tunnels, and storage of spoil.

Site planning

3. The protection of soil quality was almost entirely driven by agricultural land quality and the desire to minimise the impact of the scheme on 'best and most versatile' land. A Code of Construction Practice defined the environmental requirements of the project and an Agricultural Management Plan (AMP) was produced as a generic plan to be passed into contract documentation. Opportunities were taken at the planning stage to propose the use of derelict pits for disposal of surplus excavation spoil and subsequent restoration with subsoil and topsoil.
4. The AMP included a Schedule of Standards and Soil Handling Techniques and, as much of the emphasis was on restoring land that would only temporarily be needed for the project, it was based on best practice within the mineral industry. It included:
 - a pre-disturbance record of soil physical characteristics;
 - specification for land being restored to agriculture after temporary use;
 - a method of assessing suitability for handling soil based on plastic limit;
 - advice on stripping topsoil and subsoil to the correct depth;
 - recommendation of the most suitable equipment for soil handling;
 - advice on soil storage (e.g. topsoil no higher than 3m and subsoil no higher than 5m);
 - advice on alleviating compaction after replacement, and a requirement for a five-year aftercare scheme.

Soil management during construction

Implementation

5. After contracts were awarded by Rail Link Engineering in October 1988, successful tenderers had to produce their own work plans containing method statements as to how they were going to handle soil, a physical characteristics record of each parcel of land to be affected and a detailed reinstatement specification and target land quality. To do this each contractor had to appoint a consulting soil scientist.
6. A detailed audit trail had to be kept of all soil materials required for land being eventually reinstated and soil being retained for reuse in the restoration process had to be stored separately from those identified for reuse elsewhere or removal off site. Non-agricultural soils such as those from ancient woodland in the line of the route were characterised in detail and plans made to translocate the soil, sometimes in three separate layers, to receptor sites to recreate a similar soil profile on them. Soil stripping and placement depths were specified in detail and soil handling involved no trafficking of donor or replaced soil and direct movement from donor to receptor site wherever possible.
7. After each area was reinstated, a condition report was prepared by the contractor's consultant and agreed with Rail Link Engineering's supervising soil consultant with remedial actions agreed as required.

Contractor contribution

There were two specified work methods for soil placement:

- by box-scraper with subsequent loosening (by ripping) to a depth of 60cm
- by dumper and backacter, using the loose-tipping method which involves no vehicle movements over placed soil.

The contractor for the contract east of Maidstone had a lot of heavy clay soils to deal with and was not happy with the suggested methods. In discussion with his and Rail Link Engineering soil consultants the contractor proposed a method that was later successfully adopted. The procedure consists of building a relatively thick peninsula of topsoil out at pre-determined intervals over the respread subsoil. Dump trucks reverse along the peninsula, thus progressively extending it by tipping more topsoil at the end. Then a light tracked bulldozer is used to spread out the soil to the required thickness over the rest of the area. The method has subsequently gained favour with statutory authorities.



Starting a 'peninsula' of topsoil

Soil management during construction

Lessons learnt

- Through careful planning, soil sustainability issues identified at an early stage of a project can be carried through to become part of the environmental programme for the construction phase.
- A large infrastructure project such as the CTRL, and one impacting on such a large area of undisturbed land, can justify a high level of supervision by soil specialists during construction.
- Method statements devised prior to construction might need to be modified to meet specific on-site circumstances or incorporate new ideas.
- Close liaison between the client's consultant and the contractors' consultants ensured that soils were used sustainably throughout the projects.

5.2 Topsoil stripping

Why?

1. Topsoil is a finite resource and an important component of most landscape schemes within construction projects. It provides an anchorage and oxygen for plant roots, slowly releases nutrients, and, in conjunction with the underlying subsoil, retains moisture to sustain plant growth during dry periods. Once re-usable soil resources have been identified within a site it is important to strip them carefully for beneficial reuse on or off-site.
2. Not stripping topsoil from areas that are to be built on, regraded or trafficked by site vehicles will increase project costs, as the resource will be wasted.

Method

Remove surface vegetation by blading off, by scarification and raking, or kill off by application of a suitable non-residual herbicide applied not less than two weeks before stripping commences.

The method illustrated below is the preferred method for minimising damage to topsoil. It shows the transport vehicle running on the basal layer under subsoil as subsoil is also to be stripped. If only topsoil is to be stripped, the vehicle would run on the subsoil layer.

Stripping should be undertaken by the excavator standing on the surface of the topsoil, digging the topsoil to its maximum depth and loading into site or off-site transport vehicles.

Alternative stripping methods that can be shown to afford the same degree of soil protection are acceptable.

An archaeological watching brief might have to be accommodated during topsoil stripping.

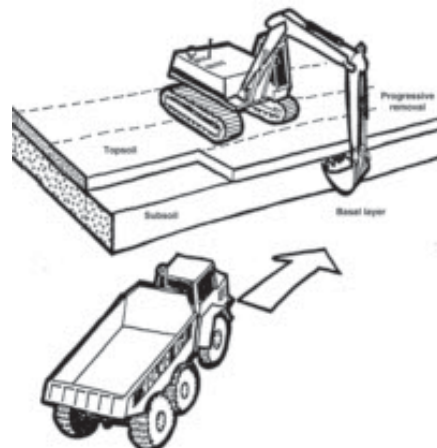

Soil management during construction

How?

3. Before commencing work on site, topsoil from all areas that are to be disturbed by construction activities or driven over by vehicles should be stripped by earthmoving plant that is appropriate to the size of the site, the volume of soil to be stripped and haul distances.
4. The selection of appropriate equipment and work practices is also important because mishandling soil can have an adverse effect on its properties – not only fertility and permeability, but also ecological diversity, the performance and visual quality of vegetated areas and recharge of underlying aquifers. Mishandling also increases the risk of flooding and off-site discharges in breach of consents.
5. Topsoil will normally be stripped to a thickness defined by depth below the surface and/or a distinct colour change. Stripping topsoil too deeply so that subsoil becomes incorporated will reduce its quality and fertility.
6. The operation should be adequately supervised and follow a detailed stripping plan (part of the Soil Resource Plan) showing soil units to be stripped, haul routes and the phasing of vehicle movements. The soil units should be defined on the site with information to distinguish types and layers, and ranges of thickness.
7. Soil generally gains strength and becomes more resistant to damage as it dries. Consequently, it should be handled in the right conditions of weather and soil moisture and using suitable machinery in an appropriate way. Soil that is wet or very moist (wetter than the plastic limit) should ideally be allowed to dry further. The presence of growing vegetation is important as it helps soil dry out quickly to depth. Multiple handling of soil materials increases the risk of damage to soil structure so should be minimised.



Adverse weather

8. If sustained heavy rainfall (e.g. >10mm in 24 hours) occurs during soil stripping operations, work must be suspended and not restarted until the ground has had at least a full dry day or agreed moisture criteria (such as a specified soil moisture content) can be met. Lighter soil (e.g. free draining sandy soil) can generally be moved at higher moisture content with less risk of damage when compared to a heavy soil (e.g. clayey soil). The earlier or later in the year that soil is moved, the greater is the risk of causing damage or having work suspended by adverse weather, although the period when soil can be safely handled is longer in the drier eastern parts of the UK than in the west. Where the soil handling technique is such that trafficking over the soil is minimal the period for soil stripping may be extended.

Soil management during construction

Do

- ✓ Strip topsoil in the driest condition possible.
- ✓ Use tracked equipment wherever possible to reduce compaction.
- ✓ Confine movement of trucks or dumpers to designated temporary haul routes.

Don't

- ✗ Incorporate vegetation into topsoil to be stored.
- ✗ Strip soils during or after heavy rainfall or when there are pools of water on the surface.
- ✗ Strip topsoil too deeply so that subsoil becomes incorporated, thereby reducing fertility.
- ✗ Remove topsoil from below the spread of trees to be retained.

5.3 Stripping subsoil

Why?

1. The subsoil is an essential component of most soil, providing storage of moisture, transmitting rainfall to deeper layers or watercourses and enabling deep rooting by trees, shrubs and grass. Only soil that is shallow over rock lacks a subsoil layer. The subsoil plays an important role in reducing surface water runoff and erosion, controlling the waterlogging of surface layers, helping vegetation and crops to withstand summer droughts and providing anchorage for trees.
2. On many sites subsoil will not need to be stripped but merely protected from damage if it is within areas designated for landscape plantings. However, on other sites it might need to be temporarily removed to make way for haul roads or, if it is of a suitable quality, recovered and reused to manufacture a topsoil substitute (e.g. brownfield sites), or to be used on its own as a low fertility surface layer for specific plantings (e.g. species-rich grassland).

How?

3. Before commencing work on site, subsoil from all areas that are to be disturbed by construction activities or driven over by vehicles should be stripped by earthmoving plant that is appropriate to the size of the site, the volume of soil to be stripped and haul distances.
4. The selection of appropriate equipment and work practices is also important because mishandling soil can have an adverse effect on its properties – not only fertility and permeability, but also ecological diversity, the performance and visual quality of vegetated areas and recharge of underlying aquifers. Mishandling can also increase the risk of flooding and off-site discharges in breach of consents.
5. The operation should be adequately supervised and follow a detailed stripping plan showing soil units to be stripped, haul routes and the phasing of vehicle movements. The soil units should be defined on the site with information to distinguish types and layers, and ranges of thickness.

Soil management during construction

6. Soil generally gains strength and becomes more resistant to damage as it dries. Consequently, it should be handled only in the right conditions of weather and soil moisture and using suitable machinery in an appropriate way. Soil that is wet or very moist (wetter than the plastic limit) should be allowed to dry further. Multiple handling of soil materials increases the risk of damage to soil structure so should be minimised.

Adverse weather

7. If sustained heavy rainfall (e.g. >10mm in 24 hours) occurs during soil stripping operations, work must be suspended and not restarted until the ground has had at least a full dry day or agreed moisture criteria (such as a specified soil moisture content) can be met. Lighter (i.e. sandier) soil can generally be moved at higher moisture content with less risk of damage than a heavy (i.e. clayey) soil. The earlier or later in the year that soil is moved, the greater is the risk of causing damage or having work suspended by adverse weather, although the period when soil can be safely handled is longer in the drier eastern parts of the UK than in the west. Where the soil handling technique is such that trafficking over the soil is minimal the period for soil stripping may be extended.

Method

Topsoil should first be stripped from all areas from which subsoil is to be removed for reuse.

The preferred soil stripping method is illustrated below. Within each soil unit the soil layers above the base/formation layer are removed in sequential strips that can be up to 6m wide (the reach of a 360° excavator). Using an excavator bucket with teeth is preferable to using one without. Where there is a cover of topsoil, that layer is removed first before stripping subsoil to the specified depth. The soil transport vehicle runs on the layer beneath the subsoil.

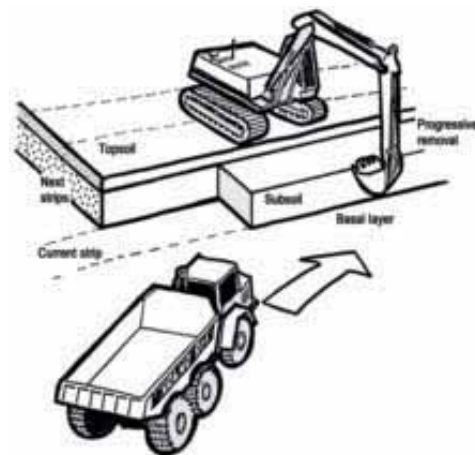

Alternative stripping methods that can be shown to afford the same degree of soil protection are acceptable.

An archaeological watching brief might have to be accommodated during subsoil stripping.

Do

- ✓ Strip subsoil in the driest condition possible.
- ✓ Use tracked equipment wherever possible to reduce compaction.
- ✓ Confine movement of trucks or dumpers to designated temporary haul routes.

Don't

- ✗ Strip soils during or after heavy rainfall or when there are pools of water on the surface.
- ✗ Mix subsoils of different quality and composition.

5.4 Soil stockpiling

Why?

1. Soil often has to be stripped or excavated during the construction process. In order to enable its reuse on site at a later stage, soil needs to be stored in temporary stockpiles to minimise the surface area occupied, and to prevent damage from the weather and other construction activities.



How?

2. The main aim when temporarily storing soil in stockpiles is to maintain soil quality and minimise damage to the soil's physical (structural) condition so that it can be easily reinstated once respread. In addition, stockpiling soil should not cause soil erosion, pollution to watercourses or increase flooding risk to the surrounding area.
3. When soil is stored for longer than a few weeks, the soil in the core of the stockpile becomes anaerobic and certain temporary chemical and biological changes take place. These changes are usually reversed when the soil is respread to normal depths. However, the time it takes for these changes to occur very much depends on the physical condition of the soil.
4. Handling soil to create stockpiles invariably damages the physical condition of the soil to a greater or lesser extent. If stockpiling is done incorrectly the physical condition of the soil can be damaged irreversibly, resulting in a loss of a valuable resource and potentially significant costs to the project. The Soil Resource Survey and Soil Resource Plan should set out any limitations that the soil may possess, with respect to handling, stripping and stockpiling.
5. The size and height of the stockpile will depend on several factors, including the amount of space available, the nature and composition of the soil, the prevailing weather conditions at the time of stripping and any planning conditions associated with the development. Stockpile heights of 3-4m are commonly used for topsoil that can be stripped and stockpiled in a dry state but heights may need to be greater where storage space is limited.
6. Soil moisture and soil consistency (plastic or non-plastic) are major factors when deciding on the size and height of the stockpile, and the method of formation. As a general rule, if the soil is dry (e.g. drier than the plastic limit) when it goes into the stockpile, the vast majority of it should remain dry during storage, and thereby enable dry soil to be excavated and respread at the end of the storage period. Soil in a dry and non-plastic state is less prone to compaction, tends to retain a proportion of its structure, will respread easily and break down into a suitable tilth for landscaping. Any anaerobic soil also usually becomes re-aerated in a matter of days.
7. Soil stockpiled wet or when plastic in consistency is easily compacted by the weight of soil above it and from the machinery handling it. In a compacted state, soil in the core of the stockpile remains wet and anaerobic for the duration of the storage period, is difficult to handle and respread and does not usually break down into a suitable tilth. A period of further drying and cultivation is then required before the soil becomes re-aerated and acceptable for landscaping.

Soil management during construction

Stockpiling methods

8. There are two principal methods for forming soil stockpiles, based on their soil moisture and consistency.
9. Method 1 should be applied to soil that is in a dry and non-plastic state. The aim is to create a large core of dry soil, and to restrict the amount of water that can get into the stockpile during the storage period. Dry soil that is stored in this manner can remain so for a period of years and it is reuseable within days of respreading.
10. Method 2 should be applied if the construction programme or prevailing weather conditions result in soil having to be stockpiled when wet and/or plastic in consistency. This method minimises the amount of compaction, while at the same time maximising the surface area of the stockpile to enable the soil to dry out further. It also allows the soil to be heaped up into a 'Method 1' type stockpile, once it has dried out.

Soil stockpiling

Soil should be stored in an area of the site where it can be left undisturbed and will not interfere with site operations. Ground to be used for storing the topsoil should be cleared of vegetation and any waste arising from the development (e.g. building rubble and fill materials). Topsoil should first be stripped from any land to be used for storing subsoil.

Method 1 – Dry non-plastic soils

The soil is loose-tipped in heaps from a dump truck (a), starting at the furthest point in the storage area and working back toward the access point. When the entire storage area has been filled with heaps, a tracked machine (excavator or dozer) levels them (b) and firms the surface in order for a second layer of heaps to be tipped. This sequence is repeated (c & d) until the stockpile reaches its planned height. To help shed rainwater and prevent ponding and infiltration a tracked machine compacts and re-grades the sides and top of the stockpile (e) to form a smooth gradient.

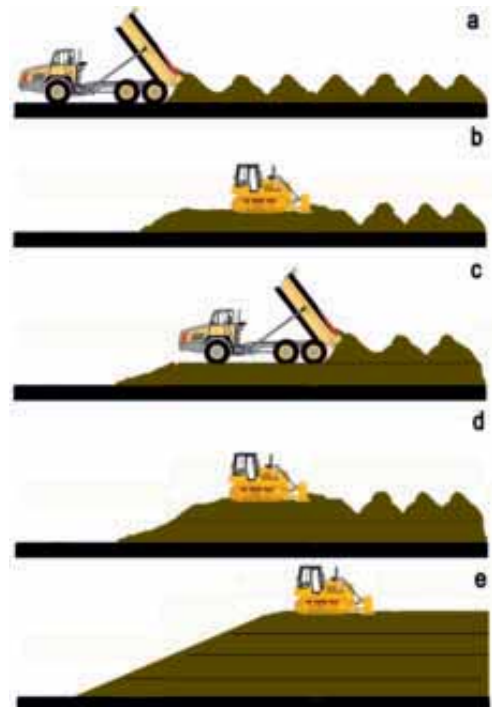

Soil management during construction

Method 2 – Wet plastic soils

The soil is tipped in a line of heaps to form a 'windrow', starting at the furthest point in the storage area and working back toward the access point (a). Any additional windrows are spaced sufficiently apart to allow tracked plant to gain access between them so that the soil can be heaped up to a maximum height of 2m (b).

To avoid compaction, no machinery, even tracked plant, traverses the windrow.

Once the soil has dried out and is non-plastic in consistency (this usually requires several weeks of dry and windy or warm weather), the windrows are combined to form larger stockpiles, using a tracked excavator (d). The surface of the stockpile is then regraded and compacted (e) by a tracked machine (dozer or excavator) to reduce rainwater infiltration.

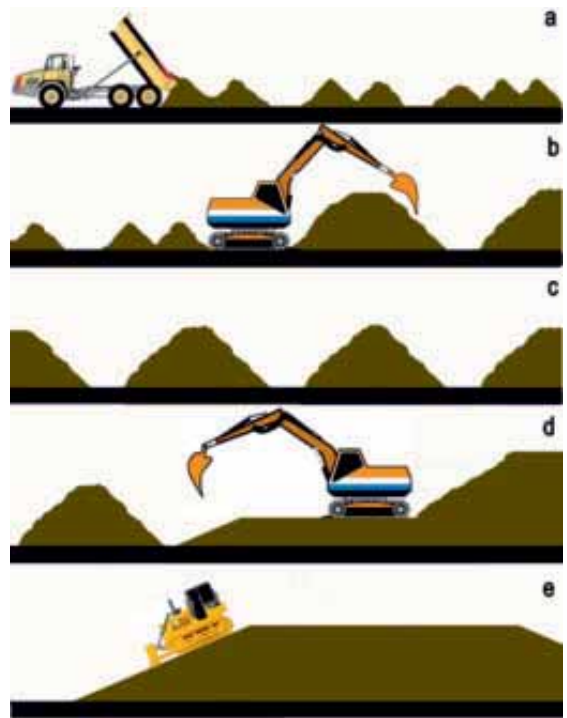

Stockpile location and stability

11. Stockpiles should not be positioned within the root or crown spread of trees, or adjacent to ditches, watercourses or existing or future excavations. Soil will have a natural angle of repose of up to 40° depending on texture and moisture content but, if stable stockpiles are to be formed, slope angles will normally need to be less than that. For stockpiles that are to be grass seeded and maintained, a maximum side slope of 1 in 2 (25°) is appropriate.

Stockpile protection and maintenance

12. Once the stockpile has been completed the area should be cordoned off with secure fencing to prevent any disturbance or contamination by other construction activities. If the soil is to be stockpiled for more than six months, the surface of the stockpiles should be seeded with a grass/clover mix to minimise soil erosion and to help reduce infestation by nuisance weeds that might spread seed onto adjacent land.
13. Management of weeds that do appear should be undertaken during the summer months, either by spraying to kill them or by mowing or strimming to prevent their seeds being shed.



Clearly defined stockpiling of different soil materials



Long term stockpile of stripped topsoil left with only weed vegetation

Soil management during construction

Waste regulations

Whenever it is envisaged that the use of the materials will occur in excess of one year from being stockpiled/stored, a time limit has to be agreed with the Environment Agency. The decision relating to the length of storage will be made within the context of the extant planning permission or agreed programme of works. Supporting information may be requested by the Environment Agency in the form of the Soil Resource Plan (e.g. site plans, cross sections and stockpile management).

Do

- ✓ Remove vegetation and waste materials from storage areas before forming stockpiles.
- ✓ Manage the site so that soil storage periods are kept as short as possible.
- ✓ Stockpile soils in the driest condition possible.
- ✓ Use tracked equipment wherever possible to reduce compaction.
- ✓ Protect stockpiles from erosion by seeding or covering them.
- ✓ Use clear signage to identify the content of stockpiles.

Don't

- ✗ Stockpile soils when wet or plastic.
- ✗ Stockpile soils of different quality and composition together, especially topsoil and subsoil.
- ✗ Stockpile subsoil or waste materials on top of topsoil.
- ✗ Locate stockpiles close to retained trees, drains, watercourses or excavations.
- ✗ Steepen stockpile sides beyond a slope of 1 in 1.75 (30°) in order to reduce the risk of erosion.
- ✗ Allow vehicles to run over stockpiles except during their construction.

Case Study 3: Poor gardens of housing development necessitate £90,000 of remedial work

1. This site was a greenfield development, where the original topsoil was stripped and stockpiled for later reuse in the gardens of houses and areas of public open space.
2. The topsoil was heavy loam, and was stripped and stockpiled during the winter months, when wet and plastic in consistency. As a consequence, the soil lost its structure and upon respreading the topsoil came out of the stockpile, in large, compacted, structureless clods. The subsoil was left in-situ during construction and became over-compacted by construction activities, including trafficking with wheeled plant and the storage of building materials.

Soil management during construction



Topsoil stockpiled when wet and plastic



Cloddy, compacted and structureless topsoil

3. Placement of topsoil was completed in winter 2005, with 150mm to 200mm of topsoil laid over subsoil that had not been ripped or decompacted. The gardens were laid to lawn using turf. The turf was healthy for the first summer, but by the onset of winter 2006 the turf began to rapidly fail and the gardens became waterlogged following periods of prolonged or heavy rainfall.



Failed garden turf



Surface water running onto adjacent paving

4. Examination of the soil in several gardens showed that the topsoil was structureless, waterlogged and anaerobic and the dead turf had begun to rot. There was virtually no root growth into the topsoil. The subsoil was relatively dry but heavily compacted. thus preventing drainage and resulting in flooding of adjacent areas such as garden patios.
5. In total, the gardens of eighteen houses out of twenty-seven had to be remediated, necessitating the temporary removal of fencing panels to gain access with machinery. The subsoil was decompacted using a single-tine ripper mounted on a small tracked excavator, and the texture and drainage of the topsoil was improved by amelioration with washed sand. All the turf had to be replaced.
6. The whole operation was undertaken at considerable cost to the developer.

Soil management during construction

Lessons learnt

- The characteristics of the site topsoil and subsoil and their limitations for reuse in landscaping should have been identified at an early stage of the development by undertaking a Soil Resource Survey.
- There was no guidance (such as a Soil Resource Plan) available to the earthworks contractor to advise on methods for stripping or stockpiling soil.
- The subsoil should have been decompacted before spreading the topsoil, to improve rainwater soakage into the substrate.

Savings that could have been made

- Ensuring that the soils were fit for purpose before laying the turf would have avoided the considerable costs (£90,000) and loss of reputation associated with remediating the soils and replacing turf.

6.1 Soil placement

Why?

1. The establishment of new landscapes, gardens, or other greenscapes on construction sites often involves the respreading of stockpiled soil or the importation of soil. The manner in which this is carried out has a significant bearing on the soil's function, and particularly its ability to support new trees, shrubs and grass.
2. It is essential to provide a structured, uncompacted and well-aerated soil profile for the successful establishment and subsequent growth of plants and grass. However, where heavy machinery and large volumes of soil are excavated and stored, soil structure can easily be destroyed by over-compaction. This leads to problems of waterlogging and anaerobism, which are detrimental to plants in two main ways. Anaerobic bacteria produce ammonia and methane gases harmful to plant roots, and, without oxygen, plant roots are unable to take up water and nutrients. Restricted rooting increases the risk of trees being affected by wind throw (the uprooting of trees by wind).
3. The consequence of over-compacted soil is not only poor establishment or failure of plantings but also increased surface water runoff and surface ponding that reduces the visual and physical amenity of the landscape or garden and can contribute to localised flooding.



The symptoms of over-compaction of soil on the amenity areas of new housing estates: struggling trees; poor grass growth; and surface ponding after heavy rain.

How?

4. Almost all soil is physically degraded to a greater or lesser extent during soil stockpiling, handling and placement. The potential quality and the ultimate suitability of the soil depends on how well its soil structure is restored during placement.
5. Provided the soil is spread and prepared correctly, damage to soil structure can be kept to a minimum and the soil can usually recover to a healthy state quickly. In order to achieve this, it should be handled only when dry or slightly moist and using suitable machinery in an appropriate way. Multiple handling of soil materials increases the risk of damage to soil structure, so should be minimised.
6. The 'loose tipping' method, using dump trucks and hydraulic excavators to move and spread the topsoil, is the most appropriate method to use.

Loose-tipping method

This method entails working to a strip system (the width of the strip determined by the reach of the excavator), and replacing soil sequentially across the soiling area. The receiving ground, whether a basal layer or compacted subsoil is first loosened with a wing-tine ripper.

A hydraulic excavator, fitted with a toothed-bucket to avoid excessive smearing, should be used to load the soil materials from the source area or stockpile into a dump truck which then discharges them onto the receiving surface. An excavator stands next to the newly dropped soil and spreads this to the required thickness. If there is to be more than one soil layer (i.e. if both topsoil and subsoil are being replaced) then the whole length of the strip is restored with subsoil before the process is repeated with topsoil. The topsoil is lifted onto the subsoil without the excavator travelling on the newly placed subsoil. Only when the strip has been completed is the next one started.

If soil is cloddy in structure, the excavator bucket can be used to break up the clods. Large stones can be removed during the operation.

Modified versions of the loose-tipping method, for use when both subsoil and topsoil are to be placed, include spreading the subsoil as described above but then spreading the topsoil layer out using a low ground pressure dozer. Providing that soil conditions are suitably dry and dozer movements are minimised, this can gently consolidate the placed soil without causing over-compaction.

The loose-tipping method (topsoil spreading only)

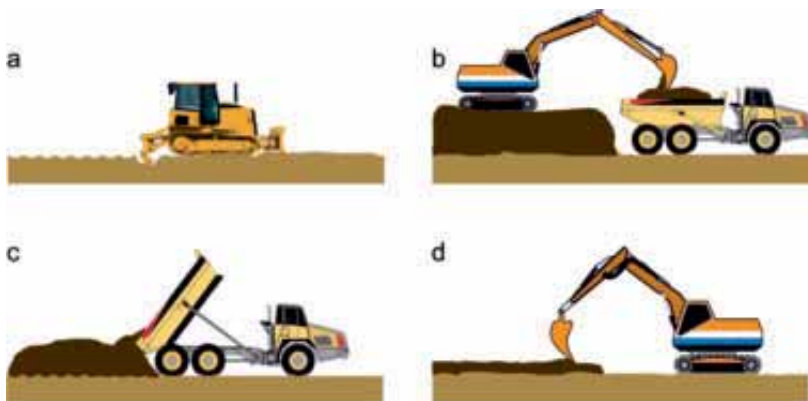

- loosening the subsoil of the receiving ground*
- loading of topsoil from stockpile*
- backtipping topsoil onto loosened subsoil*
- levelling topsoil*

The loose-tipping method (topsoil and subsoil spreading)

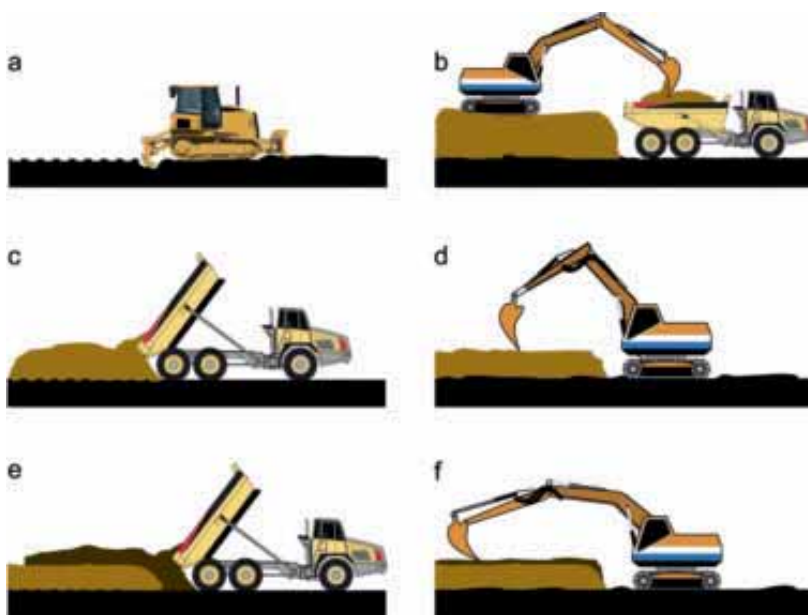

- loosening the substrate of the receiving ground*
- loading of subsoil from stockpile*
- backtipping subsoil onto loosened substrate*
- levelling subsoil*
- backtipping topsoil*
- spreading topsoil over subsoil using excavator working on substrate*

Relief of compaction

7. On most construction sites, the receiving layer will have been compacted by vehicles, foot trafficking or the storage of building materials. Therefore, prior to spreading soil the substrate should be properly decompact to break up any panning to reduce flood risk and to promote deeper root growth. A small (1-5 tonne) to medium sized (13 tonne) tracked excavator, fitted with a single rigid tine is effective in restricted areas, such as in planting beds and road verges. In more open areas, a tractor-drawn subsoiler is capable of loosening soil that is not too heavily or deeply compacted. In some instances, compressed air injection can be used to decompact the soil profile.
8. Deep compaction can only be effectively relieved using heavy duty ripper equipment, such as the single rigid tine device pictured below. For loosening to be most effective, it should be carried out when the soil is sufficiently dry to the full depth of working, otherwise the tine merely cuts and smears the subsoil rather than lifting, fracturing and loosening it. A toothed excavator bucket is not an appropriate tool for ripping soil.



Top (from left to right): Ripping by tractor-drawn tines, Large winged-tine ripper, Topsoil rake used on a 3 tonne excavator

Bottom: Single ripper tooth used for relieving compaction to a depth of 600 mm

Topsoil thickness

9. Topsoil placement thickness will depend on the anticipated rooting depth of the plants to be established and the quality of the underlying subsoil. Trees and shrubs require a much greater rooting depth than grasses, though this does not have to be made up entirely of topsoil. Topsoil at least 150mm deep is desirable for lawns and mown amenity grass and can beneficially be placed more deeply (up to 400mm thick) for trees and shrubs. However, topsoil does not normally perform well below a depth of 400mm from the surface, where there is an increase in self-compaction and where the biochemical oxygen demand (BOD) often exceeds the rate of aeration. This often results in the development of anaerobic conditions that are detrimental to plant root functions. Subsoil, which has a lower BOD, should, therefore, always be used to create rooting depths in excess of 400mm.

Topsoil cultivation

10. After respreading topsoil, any large, compacted lumps should be broken down by appropriate cultivation to produce a fine tilth suitable for planting (<50mm maximum aggregate size), turving and seeding (<10mm maximum aggregate size).
11. Topsoil that has been stored in a stockpile is often compacted and anaerobic. It should therefore be cultivated to its full depth using appropriate tillage equipment to decompact and fully re-aerate. Only when the topsoil has been fully re-aerated will it be satisfactory for planting, turving or seeding. More than one cultivation may be required to re-aerate the entire thickness of topsoil. Undesirable material (e.g. stones, fill materials and vegetation larger than 50mm in any dimension) brought to the surface during cultivation should be removed by picking or raking.

Adverse weather

12. If sustained heavy rainfall (e.g. >10mm in 24 hours) occurs during soil handling operations, work must be suspended and not restarted until the ground has had at least a full dry day or agreed moisture criteria (such as 'drier than the plastic limit') can be met. Lighter soil can generally be moved at a higher moisture content without damage than a heavy soil.
13. The earlier or later in the year that soil is moved, the greater the risk of causing damage or having work suspended by adverse weather, although the period when soil can be safely handled is longer in the drier eastern parts of the UK than in the west. Where the soil handling technique is such that trafficking over the soil is minimal (e.g. the 'loose tipping method' described above) the period for soil stripping may be extended.

Landscape, habitat or garden creation

Do

- ✓ Handle and place soil in the driest condition possible.
- ✓ Use tracked equipment wherever possible to reduce compaction.
- ✓ Decompress subsoil before placing topsoil.
- ✓ Fully re-aerate anaerobic topsoil before planting, turfing or seeding.
- ✓ Ensure that the physical condition of the entire soil profile (topsoil and subsoil) will promote sufficient aeration, drainage and root growth.

Don't

- ✗ Place or cultivate soils during or after heavy rainfall or when soils are plastic.
- ✗ Take construction machinery over topsoil or subsoil that has been placed.
- ✗ Place topsoil too deeply – 'more' is not necessarily 'better'.
- ✗ Plant into anaerobic topsoil.

Case Study 4: Decisions not to follow soil specifications cost company £25,000

1. Even where a good specification has been prepared for subsoil and topsoil management, there is seldom quality control of the works to ensure that desired outcomes are achieved.
2. An example is from a small development of 37 houses in Lancashire which necessitated the tipping of subsoil excavated from the development platform onto an adjacent field, which was then to be turned into public open space under a Section 106 agreement. A detailed specification was prepared by the developer's consulting landscape architect and stated that:
 - subsoil to receive topsoil should be thoroughly broken up to a depth of 150 mm and cleared of all roots, stones and debris with any one dimension greater than 75 mm;
 - subsoil should be graded after loosening but not traversed by heavy machinery;
 - topsoil should conform to 'BS3882:1994 fertile agricultural soils of uniform composition throughout, of light or medium texture with stones not exceeding 50 mm in any one dimension'.
3. Despite the detailed soil specification, including recommended quality control stages, neither the landscape architects nor other suitably qualified professionals were retained to supervise the contractors and check that the specifications were followed. Site clearance soil was used rather than fertile agricultural soil, the local planning authority was dissatisfied, refused to adopt the open space and legal action ensued. Investigation showed that the substrate was very compact and probably hadn't been loosened or stone picked, the topsoil had an excessive inclusion



One of many items of debris encountered in the imported topsoil during remedial works

Landscape, habitat or garden creation

of stones and debris (see image) and there was a mismatch between the soil and seed mix specified. Remedial works demanded by the local authority could have cost the developer £50,000 and costs of almost half that amount were eventually incurred.

Lessons learnt

- Close liaison between the developer, contractor and advisor should be retained throughout the project to ensure that the specifications and plans are followed.
- Soils should be loosened and stone-picked before spreading.

Savings that could have been made

- Ensuring that the soils were fit for purpose and that the specifications were followed would have avoided costs of £25,000 associated with remedial work.

6.2 Sourcing and importing topsoil

Why?

1. On many sites topsoil is either completely absent or there is insufficient quantity to meet landscaping needs. When site preparation commences, even on sites that have adequate topsoil, space constraints might necessitate sale or disposal off-site and importation of new topsoil later in the project.

How?

2. Before considering importing topsoil, soil resources on site should have been properly investigated through a Soil Resource Survey that evaluates the quality, quantity and suitability of all on-site resources (topsoil and subsoil) for the intended landscape scheme.
3. When it is necessary to source topsoil from outside the site, it is worth understanding the materials that are available in the construction industry, and the potential implications of using them for landscaping purposes. The term 'topsoil' can mean a whole variety of things, depending on whether you are buying, selling, hauling, using, specifying or testing the material. Many end-users still believe that all topsoil comes from green fields, but in reality, there are now a broad range of 'soil-based' materials sold as topsoil in the landscape and construction industry, and not all of them are suitable for the intended purpose.
4. There are essentially three main varieties of topsoil available, *Natural Topsoil*, *Manufactured Topsoil* and *Skip Waste Soil*. Over the last few years, the last two of these have increased in availability because of:
 - changes in legislation to promote recycling and waste recovery, and reduce the reliance on landfill.
 - increased production of organic soil improvers such as green compost and biosolids.
 - the decline of available natural topsoil, as less greenfield sites are developed.

Natural topsoil

5. Natural topsoil is derived as a by-product of development of greenfield sites and, sometimes, from undisturbed and uncontaminated areas of brownfield sites. It is illegal to remove topsoil (other than for turf-cutting) from agricultural or forestry land without planning consent. When sites are developed with the benefit of a consent, topsoil is normally stripped off before construction commences, and any surplus removed for reuse elsewhere. As a consequence, the availability of natural topsoil fluctuates as it only becomes available at the time of a topsoil strip and might not be available at all in urban centres remote from greenfield development.
6. Not all natural topsoil is suitable for all landscape use, as it can range from a crumbly loam to an acid, nutrient-deficient sand or a strongly alkaline clay. Whilst many topsoils are suitable for general landscape applications, those with more extreme characteristics are not, and their use can result in widespread plant failures. For example, silty topsoil is excellent for agricultural crop production, but makes very poor landscaping soil, due to its weak structure and poor handling ability. Temporary storage can also render topsoil unsuitable for its intended use.



Good, reusable natural topsoil



Damaged, heavy clay natural topsoil

Manufactured topsoil

7. Manufactured topsoil is a soil that is formed when two or more components are intimately mixed to form a rooting medium. Traditionally, these have been termed 'rootzones', and consist of a mixture of sand and natural topsoil at varying proportions, e.g. 70% sand and 30% topsoil. These are mainly used for sports applications, where they provide an ideal playing surface and free-draining rooting medium. As these are processed materials, using high value components, they are expensive. More recently a broader range of manufactured topsoil has become available, usually as the result of blending overburden and subsoils with various bulky organic materials, such as green compost and treated biosolids.
8. In many instances, these materials provide a good alternative to natural topsoil as long as the correct components have been selected and blended to correct ratios. Their attributes can potentially include consistent composition, year-round availability, and freedom from weeds and contaminants. However, the exact opposite can be the case where unsuitable soil or additives are used, or the manufacture process does not have the necessary quality control measures.

Skip waste soil

9. Unfortunately, one of the main alternatives to natural topsoil or properly manufactured topsoil is 'skip waste soil'. This is offered to the unsuspecting contractor or landscaper as 'general purpose topsoil' or 'turfining soil' or 'screened topsoil', from suppliers who have no supporting technical information to confirm the quality and suitability of their 'product'. This should not be confused with *natural topsoil* that has been screened to remove larger stones, as a means of improving its composition.



10. Skip waste soil is the result of screening materials derived from the 'muck away' site clearance operations. The coarse element is screened out and used as recycled aggregate whilst the fines (soil fraction) are sold as 'topsoil'.
11. Skip waste soils are often reused without the necessary Environmental Permit exemptions in place.
12. Skip waste soil usually consists of a mixture of topsoil, subsoil, clay and numerous fragments of building waste materials – brick, concrete, mortar, ash, clinker, and to a lesser extent asbestos, glass, metal, wood and plastic. In terms of its physical and chemical soil properties, the material is usually extremely alkaline, saline, infertile, and can often contain elevated levels of chemical contaminants (heavy metals, hydrocarbons) and 'sharps' such as glass and ceramic shards. This material often has a fine granular structure and may slump or cap when used as a landscape soil, leading to drainage and vegetation growth problems and even excess runoff.



13. However, as topsoil users are unaware of its detrimental characteristics, and see the material as 'soil', skip waste soil still finds a place in the landscape industry. Where it is inappropriately used to plant semi-mature trees or ornamental shrubs, this often results in either plant failure or, at the very least, stunted growth.
14. This material is at the fringe of the requirements for a landscaping topsoil. It does not normally meet the criteria for any of the British Standard BS3882 topsoil grades and would not be considered suitable for the majority of landscaping projects where, either the end-use is sensitive (e.g. domestic gardens), or the landscape scheme contains demanding trees and shrubs, or the creation of specific habitats.
15. Such soil materials may be considered for alternative uses within the construction and land restoration sectors (provided the necessary Environmental Permit exemption is in place), such as engineering backfill or acoustic bunds.

Topsoil assessment

16. To ensure that the topsoil is suitable for the intended purpose, or meets the contract specification, it is important to have the source independently assessed against a Topsoil Specification that sets out what should and should not be in the topsoil and that ensures that an effective growing medium is provided. The most functional specifications are those that list which properties the topsoil should possess prior to planting, turfing or seeding. These normally include:
 - Visual examination – soil structure, consistency, foreign matter, etc.
 - Particle size analysis (texture) and stone content.
 - pH and salinity values.
 - Content of major plant nutrients.
 - Organic matter content.
 - Maximum levels of potential contaminants (e.g. heavy metals, hydrocarbons, cyanide, phenols).
17. The values set against each property will vary depending on the required performance of the topsoil and will not be the same for every landscape project. It is often appropriate to have more than one specification if different 'landscape habitats' are to be established e.g. tree pits and wildflower grassland.

Sampling and testing

18. For topsoil that is to be imported to site, sampling techniques will vary, depending on whether the topsoil is still in-situ, or already stockpiled. Sampling should be undertaken by suitably qualified personnel.
 - Topsoil that has not yet been stripped should be sampled to its full depth. A separate topsoil sample should be taken from each of the different soil areas and from sub-areas of contrasting land use within them. To ensure accurate representation of each sampling area, several incremental samples should be taken across it and mixed together for analysis. Sampling patterns based on a rectilinear grid or a random 'figure of W' are equally suitable.

Landscape, habitat or garden creation

- From stockpiles, point samples should be taken at regular intervals from both the surface 1m and the core of the stockpile. A mechanical excavator might be necessary to sample stockpiles cores. Several incremental samples should be taken and mixed together for analysis. One composite sample should represent no more than 5000m³ of topsoil.
19. The samples should be submitted to a suitably qualified, quality-assured laboratory (e.g. ISO 17025, MCERTS, UKAS). The samples should be analysed for the parameters listed in the Topsoil Specification. Additional tests to cover more parameters, such as permeability and porosity, should be considered on a site by site basis.
 20. The results of analysis should be presented in a Certificate of Analysis, which will enable comparison with the contract specification or with the relevant British Standard.

Do

- ✓ Fully investigate on-site resources before considering a source of topsoil from outside the site.
- ✓ Use a reputable supplier.
- ✓ Establish the source of the topsoil and whether it is natural or manufactured.
- ✓ Ensure, through appropriate analysis, that the topsoil imported is suitable for the intended planting(s).
- ✓ Consider manufacturing your own topsoil.

Don't

- ✗ Accept non-documented or unverified loads of topsoil.
- ✗ Use a standard specification for all plantings as different species and land uses have different topsoil requirements.
- ✗ Accept topsoil that is too cloddy or wet or that contains visible evidence of plastics, concrete, etc.

Case Study 5: Prestige residential development benefits from careful soil investigation and specification

1. This residential development in Weybridge, Surrey was located on a 1.1ha site, which was partially wooded with mature trees and underlying scrub and partially rough grassland. The development comprised two executive detached houses with large front and rear gardens.
2. Given the vegetated state of the site it was envisaged that there would be sufficient topsoil for landscaping the gardens, and the soil would be of suitable quality. Nevertheless, prior to clearing the site, a survey by a soil scientist was undertaken to advise on the soil resources and to assist with finalising the landscape design. The survey identified very thin topsoil of a low quality and of inadequate quantity for the gardens. Below the existing topsoil was an intermittent iron pan that was impeding drainage and resulting in waterlogging above it (see image). These limitations were taken into account within the landscape design, which incorporated various measures to overcome them.

Landscape, habitat or garden creation



Site development

3. During site preparation the existing topsoil was recovered, ameliorated with fertiliser and compost and reused for low-value planting along the boundary of the site. No topsoil was removed from site. A specification was drawn up for topsoil to be imported for use in tree pits, shrub beds and lawn areas.
4. Due to the limitations of the subsoil, in particular the impeded drainage, and the high design expectations for the rear gardens, land drains were installed connected to a soakaway that was inserted into free-draining gravel deposits found at a depth of 2m below the subsoil.



Lessons learnt

- Not all Greenfield sites have a sufficient quantity or quality of topsoil for new developments. Just because a site is heavily vegetated doesn't mean there is a lot of topsoil or that the topsoil is good enough for reuse.
- Undertaking a Soil Resource Survey at the early stages of a development ensures that the necessary information is available in time to make modifications to the landscape design.
- Subsoil conditions must be considered as these affect the function of the topsoil.

Savings that were made

- Realising the limited soil resources of the site at an early stage ensured that the landscape design included measures to overcome the problems. There was no delay, and hence cost, to the project for re-design.
- There were no delays during landscape construction for sourcing imported topsoil or drainage materials.
- The landscape scheme was a success with no plant failures. This ensured that the properties looked their best when they came on the market and sold quickly.

6.3 Topsoil manufacture

Why?

1. The increase in brownfield site development has resulted in a shortfall of reusable topsoil within many urban regions. Without a local source of topsoil, construction projects have to import natural topsoil from further afield or use waste soil of inferior quality. In response to these changes in development policy, techniques have been adapted to blend and process site-won or imported subsoil with organic materials to produce topsoil substitutes. This approach can offer several benefits including, cost savings, reuse of surplus subsoil, reduced transport movements to and from site, reduced landfilling and the use of recycled materials. Furthermore, as the process is controlled, the product can be modified to suit particular planting requirements by altering mixing ratios of the various components and/or adding particular materials to the mixture.



How?

2. Topsoil manufacture is the term given to the controlled process where a suitable soil-forming material or mineral component such as subsoil, waste sand or overburden is blended with an appropriate source of organic matter, such as green compost, spent mushroom compost or biosolids (sewage sludge), at the required mixing ratio.

Prior to construction

3. To determine whether topsoil manufacture is required and feasible for the project, the soil resources on site should have been properly investigated through a Soil Resource Survey. This should evaluate the quality, quantity and suitability of all on-site resources (topsoil and subsoil) for the intended on-site uses. Where a shortfall in topsoil is identified, the survey should consider the potential to manufacture topsoil from surplus subsoil (e.g. service trench arisings, foundation excavations). Other factors such as programme, available space and the type of landscape required should also be factored into this assessment.

Landscape, habitat or garden creation

4. If topsoil manufacture is possible, the Soil Resource Plan within the Materials Management Plan and/or Site Waste Management Plan for the project should be extended to include the methods, equipment and materials for topsoil manufacture. There are a number of methods and techniques that may be used for topsoil manufacture and these fall into two main categories, *in-situ* methods and *ex-situ* methods.

In-situ methods

5. In-situ methods are carried out directly at the soil's final location, where the organic and mineral components are spread out and thoroughly incorporated using conventional agricultural machinery and some more specialised equipment for certain tasks. This approach is efficient, but can be inflexible and needs a large operating area. As such, in-situ methods are normally best suited to large, open areas, accessible to tractor-drawn machinery.



Spreading organic matter onto subsoil



Incorporating organic matter with discs

Ex-situ methods

6. Ex-situ methods involve blending the necessary components using mobile quarrying and civil engineering machinery, including power screeners and loading shovels/excavators, before the soil is transported to its final location. This approach offers greater flexibility, and is best employed for smaller areas that are inaccessible to larger equipment, although a working area of reasonable size is required for the blending process.



Blending organic matter with mineral material



Blended topsoil

Landscape, habitat or garden creation

Waste regulations

7. Uncontaminated soil arisings that do not leave the site of origin are not considered to be waste (unless they are regarded as surplus to requirement after the development has been completed). However, if the use of the materials will occur in excess of one year from being stockpiled/stored, a time limit has to be agreed with the Environment Agency. The decision relating to the length of storage will be made within the context of the extant planning permission or agreed programme of works. Supporting information may be requested by the Environment Agency in the form of the Soil Resource Plan (e.g. site plans, cross sections and stockpile management).
8. Where soil or organic ameliorants are considered to be waste they are subject to waste management controls and an environmental permit or exemption needs to be in place.
9. Composted materials produced to the PAS100 standard and complying with the Compost Quality Protocol are considered to have ceased to be waste and the waste management controls do not apply.

Do

- ✓ Determine if there is a shortfall of site topsoil at an early stage in the project.
- ✓ Determine whether topsoil manufacture is feasible by considering the quality of surplus subsoil, programme, space and landscape requirements.
- ✓ Ensure that all soils and soil ameliorants are used in accordance with current Waste Regulations or comply with the relevant Quality Protocol.

Don't

- ✗ Wait until there is a stockpile of surplus subsoil before considering topsoil manufacture.

Case Study 6: Cost saving of £400,000 on major brownfield site construction project

1. Dartford Park, located on the site of the former Joyce Green Hospital and Littlebrook Lakes (gravel extraction and landfill) at Dartford in Kent, is a large-scale brownfield site development. The joint venture between ProLogis Developments Ltd and Dartford Borough Council proposes a comprehensive, mixed-use scheme for a combination of employment uses, Science Park with Innovation Centre, housing, local centre, primary school, leisure and recreational uses, open space and wildlife areas.
2. Dartford Park covers approximately 65ha of development land and incorporates an extensive soft landscaping scheme with a range of planting habitats, including semi-mature trees, ornamental and native shrubs, wildflower meadows and wetlands. Such a diverse scheme

Landscape, habitat or garden creation

requires a range of soil to support it. Given the site's brownfield status, it was initially assumed that it would have limited supplies of reusable soil and the intention was, therefore, to import topsoil.

3. Initial geotechnical and geo-environmental investigations failed to confirm the quality of the soil for landscaping purposes. Consequently, as part of the development design, a soil resource survey was commissioned to identify available soil resources across the site. This involved a combination of desk study, site investigation and laboratory analysis and on-going liaison between the contractors and the consultants to the project (soil scientists, landscape architects, engineers and ecologists). The survey identified a broad range of soil and soil-forming material on the site that could be used to 'manufacture' the required topsoil for the proposed landscape scheme. These included low-grade topsoil, natural subsoil, demolition arisings, waste sand and greenwaste.
4. The information gathered during the soil resource survey was used to develop a Soil Resource Plan for the project. This was incorporated into the earthworks design and dealt with the effective recovery, storage and amelioration of the soil materials to produce a range of new topsoil and growing media.
5. This attracted cost savings of approximately £400,000 over importing topsoil, and the site has reserves of topsoil that will be used for further housing and infrastructure developments.

Lessons learnt

- Brownfield sites can have reserves of reusable soils.
- Geotechnical and geo-environmental investigations can provide useful background information, but they are not sufficient to identify soil resources for landscaping works, or to advise on the soil amelioration required to improve soils.
- Close co-ordination between contractors and consultants at the early stage of projects aids the development process and cost analysis.

Savings that were made

- The reuse of site-won soils and soil-forming materials saved approximately £400,000 on the development costs.
- The soils that were used would have been otherwise surplus to requirement, and therefore would have been removed off-site to landfill.
- Imported topsoils were not required, which meant that other natural topsoils were not used.
- The reduction in off-site disposal and importation of topsoil reduced lorry movements in and out of the site, thereby reducing pollution and transport congestion.

6.4 Soil aftercare

Why?

1. A well thought out and executed Soil Resource Plan will minimise damage to soil. Nevertheless, unseasonal adverse weather conditions or other factors can result in damage to soil structure that is not immediately repaired by cultivation. Structurally-weakened soil tends to settle and self-compact after placement, consequently suffering from waterlogging and anaerobism, conditions which are not only harmful to root function and plant health but can also contribute to erosion and flooding. Waterlogging and anaerobism are the most common soil-related causes for plant failure on landscaping schemes. Even in uncompacted situations it can take between 1 and 3 years for the soil structure to stabilise and provide the necessary drainage and aeration for plant roots and the soil's fauna and flora to function properly. Maintaining soil permeability is also an important element of Sustainable Urban Drainage Systems.



How?

2. A detailed landscape maintenance programme should be prepared in conjunction with the landscape design proposals. The landscape contractor that installed the landscape scheme is normally retained for a 1 to 5 year period to maintain the landscape scheme, often on a 'defects liability' arrangement. The maintenance should include monitoring of the soil conditions to identify unsatisfactory growing conditions. This can be achieved by hand digging small trial pits or auger holes at representative locations 2-3 times during each year and particularly a few weeks after planting or turfing. At this point the soil will usually show clear signs of adverse conditions, such as a grey or olive coloration and sour odour (indicating anaerobism), and/or water seepage (indicating waterlogged conditions). Treatments will vary according to the size and scale of the planting scheme and the degree of soil problems but the following are useful for general aftercare of amenity grass and trees and shrub planting.
3. It should be noted that using "best practice" methods for handling soil will reduce issues requiring remedial work. Where issues do exist it is preferable to identify and remedy them before planting shrubs and grass seeding areas.

Amenity grass

4. The most important treatment for either new amenity grass (turfed or seeded) or retained grass areas (often subjected to trafficking during construction) is decompaction and aeration. This can be achieved in a number of ways depending on the size of the area, access and depth required. Tractor-drawn or self-propelled equipment can be used to *verti-drain*, *slit* or *spike* the turf and topsoil to break up any panning and compaction.

Landscape, habitat or garden creation

5. This in turn improves aeration, drainage and root function. For small grass areas, or where access is limited, spiking the topsoil with a hand fork is also effective. Often treatments that can be considered include: fertiliser applications, herbicide application, top dressing with sand, soil or compost and over-seeding to improve the grass cover.

Trees and shrubs

6. Monitoring the soil conditions in new tree pits and shrub planting beds is essential to identify any problems before they harm the trees and shrubs. Tree pits can act as sumps for draining water which leads to anaerobic conditions, root rot and ultimately the deterioration or complete failure of the tree. If such conditions occur, opening up the pit to dry out the soil, and even pumping the stagnant water out, should be considered.

Planting areas

7. The application of wood or bark mulch to planting beds is widely practiced to reduce weed emergence and water evaporation. However, operation of spreading it requires trampling on the soil to gain access. Also, the weight of thick layers of mulch can consolidate the soil surface leading to poor water infiltration and gaseous exchange (aeration). The resulting compaction can be relieved by spiking the soil with a hand fork between the plants, which loosens and creates pores in the upper soil layer. On large areas, or where compaction is deeper than about 250mm, mechanised treatments can be employed to treat the soil without disturbing the plants. These include the injection of compressed air down to 1 metre to fissure and crack the soil. Various aggregates and additives can also be injected to keep the fissures open.
8. To maintain the fertility of the topsoil, applications of fertiliser should also be included within the maintenance programme, and particularly in the first few years. Compound, slow-release or controlled-release fertilisers are the most appropriate for tree and shrub topsoil, with one application often releasing a range of nutrients during the growing season.

Retained Trees

9. The soils supporting trees that have been retained on site during the construction may have suffered from disturbance or trafficking. Prior to handover, following completion of the development, an assessment should be made, and if necessary, remedial action taken to repair damage to the soil and roots. This may include enhancing soil structure, irrigation, improving fertility or inoculation with beneficial fungi.

Do

- ✓ Ensure that soil health as well as plant health is closely monitored during the aftercare period.
- ✓ Correct deficiencies as soon as they are detected.

Don't

- ✗ Rely on aftercare as an alternative to good soil management – careful soil handling, storage and placement will save on aftercare costs and result in long-term benefits to the development.
- ✗ Assume that soils will function adequately immediately after planting.

6.5 Uses for surplus topsoil

Why?

1. Soil is an important component for supporting life and performs a number of key environmental, social and economic functions. One hectare of topsoil, the most productive soil layer, can contain up to 5 tonnes of living organisms but because it can take more than 500 years to form 2cm, topsoil is in practical terms non-renewable. Yet in many localities, particularly urban areas, uncontaminated topsoil is in short supply for creating gardens, parks, roadside verges and landscaping schemes. Consequently it is important to try and avoid wastage of this important resource.

How?

2. Before deciding that soil is surplus to requirements, soil resources on site should have been properly investigated through a soil resource survey that evaluates the quality, quantity and suitability of all on-site resources (topsoil and subsoil) for the intended on-site uses. This should lead to development of a Soil Resource Plan as part of the Materials Management Plan and/or the Site Waste Management Plan for the project. Only when the required quantity has been set-aside for use on site for landscaping, gardens, etc. should other uses be considered.



Permanent storage created for surplus topsoil stripped from a greenfield site in Devon, despite there being demand for topsoil in the locality.

3. In reality, surplus topsoil is more likely to meet an off-site demand than subsoil, though there will sometimes be uses for the latter in restoring landfills, spoil tips, etc. or for blending with composts or biosolids to manufacture a growing medium that may have a commercial outlet. An off-site use for surplus topsoil should always be preferred to burial on site or sending it to landfill.

Prior to development

4. Discussions should take place with the groundworks contractors and the local authority to try and identify nearby land reclamation or brownfield development sites where soil resources are absent and where there is a realistic potential of using some of the soil surpluses that will be created by development. It should be noted that the potential might only be realised if the soil surplus is realised in the same period as the off-site demand exists.

Landscape, habitat or garden creation

	Area m ²	Topsoil		Subsoil	
		Thickness m	Volume m ³	Thickness m	Volume m ³
Yield					
Phase 1 units	11040	0.3	3312	0.25	2760
Phase 2 units	15110	0.3	4533	0.25	3778
Haul/access road	3433	0.3	1030	0.25	858
Stockpiling area	4500	0.3	1350	0	0
			10225		7396
Need					
Car park & road verges	1200	0.2	240	0.3	360
Southern park	4500	0.2	900	1.2	5400
Peripheral landscaping	3450	0.2	690	0.5	1725
			1830		7485
Surplus			8395		0

Example of a simple spreadsheet for soil surplus calculation. Excess subsoil is being used to create landscaping mounds in southern park

Waste permitting

5. Reference should be made to current waste legislation and guidelines (e.g. The *Definition of Waste: Development Industry Code of Practice* – September 2008), or enquiries made to the Environment Agency, to determine whether the surplus soil will be classified as waste or not.
6. If surplus soil arisings (including topsoil) do not leave the site of origin after the development has been completed they may be regarded as waste, and could be subjected to the appropriate Environmental Permit or exemption. Materials should be used in the quantities necessary for that use. The use of an excessive amount of soil will indicate that it is being disposed of and is therefore a waste.
7. Where soil materials (including topsoil) are exported from a construction site (even temporarily) they are classified as a waste.
8. If the soil can be ‘fully recovered’ and appropriately reused on another site (e.g. BS3882 certified topsoil reused for another landscape project), it can be dealt with using the relevant exemption within the Environmental Permitting (England and Wales) Regulations 2007. The main exemptions relevant to soil reuse are Paragraph 7 (land treatment – agricultural land) and Paragraph 9 (reclamation or improvement of land – non-agricultural land). These exemptions have to be notified to the Environment Agency and the notifications need to be accompanied by proof of benefit and a pollution risk assessment.
9. Alternatively, the soil needs to be taken to an appropriately permitted treatment facility for recovery or, as a last resort, be disposed of at landfill. If the surplus soil is sent to landfill it will be subject to landfill tax.

Landscape, habitat or garden creation

Do

- ✓ Calculate soil surpluses at an early stage in the project.
- ✓ Make use of contractor contacts and local authority knowledge to seek sustainable off-site uses.
- ✓ Ensure that all on-site and off-site uses are in accordance with Waste Regulations.

Don't

- ✗ Bury topsoil deeply on site unless there are no sustainable off-site uses and there is no risk to significant harm to humans and the wider environment.

References

Agricultural Land (Removal of Surface Soil) Act (1953)

http://opsi.gov.uk/RevisedStatutes/Acts/ukpga/1953/cukpga_19530010_en_1

British Standards Institute (1989): *BS4428:1989 Code of Practice for General Landscape Operations*

British Standards Institute (2007): *BS3882:2007 Specification for Topsoil (updated BS3882: 1994)*

British Standards Institute (2005): *BS5837:2005 Trees in relation to construction > Recommendations*

British Standards Institute (2005): *PAS 100:2005 Specification for composted materials*

British Standards Institute (2001): *BS10175:2001 Investigation of potentially contaminated sites – Code of Practice*

British Standards Institute (1999): *BS5930:1999 Code of practice for site investigations*

CIRIA (2004): *Sustainable drainage systems – Hydraulic, structural and water quality advice (C609)*

CIRIA (2007): *The SUDS manual (C697)*

CIRIA (2007): *Site handbook for the construction of SUDS (C698)*

CL:AIRE (2008): *The Definition of Waste: Development Industry Code of Practice*

Clean Neighbourhoods and Environment Act (2005)

Communities and Local Government (2006): *Planning Policy Statement 25: Development and Flood Risk*

<http://www.communities.gov.uk/publications/planningandbuilding/pps25floodrisk>

Council of the European Union (2004): *Directive 2004/35/CE of the European Parliament and of the Council of 21 April 2004 on environmental liability with regard to the prevention and remedying of environmental damage*

<http://eur-lex.europa.eu/LexUriServ/LexUriServ.do?uri=OJ:L:2004:143:0056:0075:EN:PDF>

Council of the European Union (2006): *Directive 2006/12/EC of the European Parliament and of the Council of 5 April 2006 on waste*

http://eur-lex.europa.eu/LexUriServ/site/en/oj/2006/l_114/l_11420060427en00090021.pdf

Defra (2004): *Defra Guidance for Successful Reclamation of Mineral and Waste Sites*

<http://www.defra.gov.uk/farm/environment/land-use/reclamation/guidance-full.pdf>

Defra (2007): *Waste Strategy for England*

<http://www.defra.gov.uk/environment/waste/strategy/strategy07/pdf/waste07-strategy.pdf>

Environment Agency (2006a): *A Guide for Developers*

<http://www.environment-agency.gov.uk/business/444304/502508/1506471/>

References

Environment Agency (2006b): *The Definition of Waste: Developing Greenfield and Brownfield sites*
http://www.environment-agency.gov.uk/business/444304/502508/1357364/?version=1&lang=_e

Environment Agency (2007): *Quality Protocol for the Production and Use of Quality Compost from Source-Segregated Biodegradable Waste*
http://www.environment-agency.gov.uk/commondata/acrobat/compostqp_1721787.pdf

Environment Protection Act (1990)
http://www.opsi.gov.uk/acts/acts1990/Ukpga_19900043_en_1.htm

Finance Act (1996): Part III Landfill Tax
http://www.opsi.gov.uk/acts/acts1996/ukpga_19960008_en_5#pt3

Highways Agency (updated 2007): *Manual of Contract Documents for Highway Works: Volume 1 Specification for Highway Works*
<http://www.standardsforhighways.co.uk/mchw/index.htm>

Ministry for Agriculture, Fisheries and Food (2000): *Good Practice Guide for Handling Soils*
<http://www.defra.gov.uk/farm/environment/land-use/soilguid/>

National Building Specification (updated 2007): *NBS Landscape*
<http://www.thenbs.com/products/nbsLandscape/index.asp>

Office of the Deputy Prime Minister (2002): *The Building Regulations Approved Document H – Drainage and Waste Disposal*
http://www.planningportal.gov.uk/uploads/br/BR_PDF_ADH_2002.pdf

Statutory Instrument No. 1056 (1994): *The Waste Management Licensing Regulations 1994*
http://www.opsi.gov.uk/si/si1994/uksi_19941056_en_1.htm

Statutory Instrument No. 1728 (2005): *The Waste Management Licensing England and Wales)(Amendment and Related Provisions)(No. 3) Regulations 2005*
<http://www.opsi.gov.uk/si/si2005/20051728.htm>

Statutory Instrument No. 3538 (2007): *The Environmental Permitting (England and Wales) Regulations 2007*
http://www.opsi.gov.uk/si/si2007/uksi_20073538_en_1.htm

Statutory Instrument No. 314 (2008): *The Site Waste Management Plans Regulations 2008*
http://www.opsi.gov.uk/si/si2008/uksi_20080314_en_1.htm

Statutory Instrument No. 2746 (1998): *The Groundwater Regulations 1998*
<http://www.opsi.gov.uk/si/si1998/19982746.htm>

Town and Country Planning Act (1990)
http://www.opsi.gov.uk/ACTS/acts1990/Ukpga_19900008_en_1.htm

Water Resources Act (1991)
http://www.opsi.gov.uk/ACTS/acts1991/Ukpga_19910057_en_1.htm

Glossary

Anaerobic	Oxygen-deficient
Basal Layer	Unweathered parent material beneath subsoil. Layer upon which subsoil may be respread.
Biochemical Oxygen Demand	The quantity of oxygen required by aerobic micro-organisms for the complete (aerobic) decomposition of a material.
Biosolids	By-product of sewage collection and treatment processes. They have been treated and/or stabilised to the extent that it is possible to beneficially reuse them. Also known as sewage sludge.
Contaminated soil	Soil containing harmful substances in such concentrations that are already causing or are capable of causing significant harm to humans, animals, plants, eco-systems, property or pollution of Controlled Waters.
Disposal	Waste management operation serving or carrying out the final treatment (i.e. treatment resulting in residues that are discarded) or final disposal (e.g. landfill) of waste, which is not intended to be reused for a useful purpose.
Green compost	A blend of botanical residues derived from garden and landscape wastes, for example grass cuttings, bark, wood, branches, leaves and weeds, composted to produce a dark organic and nutrient-rich material which is of benefit to soils and growing media to which it is added.
Groundworks	Movement of soils or rock by excavation and / or placement to create a platform for building, trenches, hollows, wells, shafts or tunnels.
MCERTS	The Environment Agency's Monitoring Certification Scheme provides a framework within which environmental measurements can be made in accordance with the Agency's quality requirements.
Non-plastic soil	A soil that does not exhibit plasticity at any moisture content, such as sand or gravel.
Plastic soil	A soil that, within a certain moisture content range, is capable of being moulded or deformed without rupture.
Plastic limit	The moisture content above which a plastic soil starts to exhibit plastic behaviour.
Ponding	The collection of water at the soil surface when there is no room available for it to infiltrate to the soil.
Recovery	Waste management operation where principal objective is to ensure the waste is reused to serve a useful and appropriate purpose.

Glossary

Ripper	Machine drawn equipment having tines capable of penetrating soil and loosening it.
Ripping	Loosening soil by the drawing through it of a tined implement.
Runoff	The flow of water over the ground surface.
Soil compaction	Over-compaction of subsoil or topsoil so that fine pores and the spaces between soil structure aggregates become closed and are unable to allow the passage of roots, water and air.
Soil contaminants	Substances which, when present in sufficient concentration, may inhibit soil function or cause a risk of significant harm to animals, humans or the environment.
Soil erosion	The detachment and movement of soil by the action of wind and flowing water.
Soil function	The ability of a soil to not only provide a platform for construction and raw materials but also provide a number of environmental services, including the support of vegetation growth, ecological habitats and biodiversity, regulating the through-flow of water, degrading, storing and transforming soil organic matter, nutrients, wastes and contaminants, and protecting archaeological remains.
Soil Resource Plan	Sets out in detail the methods, equipment, location and programme for the recovery, storage and reuse of all site topsoil and subsoil.
Soil quality	The capacity of soil to function within ecosystem boundaries to sustain biological productivity, maintain environmental quality, and promote plant and animal health.
Soil resource	The nature and volume of different qualities of topsoil and subsoil that have a potential for beneficial reuse.
Soil resource survey	A survey undertaken to delineate, quantify and characterise the topsoils and subsoils within a site.
Soil sealing	Covering of the soil surface with an impermeable material.
Soil structure	The aggregation of soil particles into larger units with spaces between that allow flow of air and water and root penetration.
Soil texture	A descriptive classification reflecting the proportions of mineral fractions (sand, silt and clay sized particles).
Spent mushroom compost	A versatile and useful compost derived from the decomposition of commercially-grown mushroom growing media, which is usually composed of straw, manure, gypsum and/or lime.

Subsoil	Weathered soil layer extending between the natural topsoil and the little weathered basal layer (e.g. geological parent material) below, or similar material within a landscaping project on to which topsoil can be spread. Subsoil usually has a lower organic matter and plant nutrient content than topsoil.
Subsoiler	Similar to a ripper (see above) but often with wings on the foot of the leg(s) to increase soil heave and shatter.
Topsoil (manufactured)	A material produced by combining mineral matter and organic matter of suitable quality (and, where appropriate, fertiliser and lime) that provides similar functions to natural topsoil.
Topsoil (natural)	Upper layer of a soil profile, usually darker in colour and more fertile than the layer below (subsoil), and which is a product of natural biological and environmental processes. The thickness of natural topsoil will vary from only a few centimetres in some sites to more than 350mm in deeply cultivated agricultural sites.
Verti-draining	The process by which a verti-drain machine punches holes (up to 300mm deep) into the soil using solid or hollow tines. This process lifts and shatters the soil to relieve compaction and improve aeration and drainage.
UKAS	The UK Accreditation Service is the sole national accreditation body recognised by government to assess organisations that provide certification, testing, inspection and calibration services.

Acknowledgements

The Code is based on a report (Code of Practice for the Sustainable Use and Management of Soils on Construction Sites, Defra Project SOIL 126), produced by Land Research Associates Ltd in association with Tim O'Hare Associates LLP.

The project was supported by a steering group from the construction industry, trade associations and regulators. Their guidance and advice is gratefully acknowledged. The members of the steering group comprised:

John Newman (BIS)
Robert Creed (Environment Agency)
Paul Mathers (WRAP)
Joanne Kwan (CIRIA)
Neil Huck (Ground Control, representing BALI)
David Lloyd (Laing O'Rourke, representing CECA)
Mark Stephen (Natural England)
Paul Thomas (Galliford Try)
Tim Beeson (Balfour Beatty)
Stephen Nortcliff (Reading University)
Alan Jemmett (Merseyside EAS)
Sam Hall (Bovis Lend Lease)

Photographs

Photographic images are supplied by Land Research Associates Ltd, Tim O'Hare Associates LLP and Stuart McRae.

PB13298 September 2009

**Nobel House
17 Smith Square
London SW1P 3JR**

www.defra.gov.uk

