

**Pursuant to section 12 of
the Weights and Measures Act 1985
Certificate No 2016 Revision 1**

Issued by:

NMO

In accordance with the provisions of section 12(8) of the Weights and Measures Act 1985, the Secretary of State for Business, Energy & Industrial Strategy hereby renews for a period of 10 years until 18 October 2027, and issues this UK national type-approval certificate to:

**Gaskell & Chambers Limited
Unit A2 Earlswood Trading Estate
Poolhead Lane
Earlswood
West Midlands B94 5EW
United Kingdom**

The necessary data (principal characteristics, alterations, securing, functioning etc) for identification purposes and conditions (when applicable) are set out in the descriptive annex to this certificate.

Under the provisions of section 12(6) of the said Act, the validity of this certificate is limited as shown below.

Note: This certificate relates to the suitability of the equipment for use for trade only in respect of its metrological characteristics. It does not constitute or imply any guarantee as to the safety of the equipment in use for trade or otherwise.

This revision replaces previous versions of the certificate.

Issue Date: 19 October 2017
Valid Until: 18 October 2027

A handwritten signature in black ink, appearing to read 'Grégory Glas', is written over a horizontal line.

Grégory Glas
Technical Manager
For and on behalf of the Head of Certification Body

CONTENTS

DESCRIPTIVE ANNEX

- CERTIFICATION NO 2016 dated 05 November 1997
 - Amendment No1 dated 05 June 1989
 - Amendment No2 dated 09 January 1990
 - Amendment No3 dated 04 July 1990
 - Amendment No4 dated 22 November 1990
 - Amendment No5 dated 27 July 1994
 - Amendment No6 dated 29 November 1994
 - Amendment No7 dated 02 June 1997
 - Amendment No8 dated 17 March 1999
 - Amendment No9 dated 25 June 1991
- CERTIFICATION NO 2016/1 dated 05 November 1997
- CERTIFICATION NO 2016/2 dated 05 November 1997
- CERTIFICATION NO 2016/3 dated 05 November 1997
- CERTIFICATION NO 2016/4 dated 05 November 1997

CERTIFICATE HISTORY



(2016)

III(2)

Certificate

Pursuant to section 12 of the Weights and Measures Act 1985

Certification Number 2016

Valid Until 5 November 1997

In accordance with the provisions of section 12 of the Weights and Measures Act 1985, the Secretary of State for Trade and Industry hereby certifies as suitable for use for trade the following pattern of a spirit measuring instrument.

Submitted by: Gaskell and Chambers Ltd
23 Chartwell Drive
Wigston
Leicester
LE8 2FL

Reference No STD 5500

Date 6 November 1987

A handwritten signature in black ink, appearing to read 'F. A. Rasey'.

for F A Rasey
Director
National Weights and Measures Laboratory
Department of Trade and Industry
Stanton Avenue
Teddington
Middlesex
TW11 0JZ

CONTENTS

CERTIFICATION NO 2016

1 INTRODUCTION

2 CONSTRUCTION

- 2.1 Mechanical
- 2.2 Legends
- 2.3 Sealing and stamping

3 OPERATION

ILLUSTRATIONS

- Figure 1 Measuring unit
- Figure 2 General arrangement of measuring unit

1 INTRODUCTION (Figure 1)

This pattern of a spirit measuring instrument is for use in measuring fixed quantities of 1/6 gill. The instrument is supplied from an inverted bottle connected to its inlet and dispenses when a cross-arm at the delivery port is raised to its maximum. A transparent chamber displays the complete charging and discharging of the instrument.

2 CONSTRUCTION (Figure 2)

2.1 Mechanical

The instrument is constructed mainly from plastic. The springs are of stainless steel and are used to return the air valve and the central spindle to their closed positions. The discharge tube is chrome plated brass. The measuring cup is made from polystyrene or S.A.N. The seals are either nitrile or silicone rubber.

The central spindle is in four parts, the lower part is the delivery tube (1) which extends through the cup (2) and has an outlet seal (3) seal retainer (4) and standard (5) with a cap (6) to retain the upper seal. The standard is provided with a cylindrical land (7) for blocking the inlet port, an 'O' ring (8) is provided to improve the sliding seal in the inlet port.

The head is provided with a cylindrical land (9) to accept the mating part on the standard. Above the cylindrical land is a divider (10) for the inlet to provide two passages through the inlet.

The standard has a rim (11) beneath the cylindrical seal which actuates the air valve (12) in the head to admit air into the cup as the instrument drains.

The upper end of the delivery tube is a cylindrical land with an 'O' ring (13) on either side of a cross bore (14), the lower end of the delivery tube is enlarged to take a snap on operating arm (15). The delivery tube and the operating arm form a mating cone drip retainer.

The delivery tube is returned to the closed position by a spring (16) acting between the spindle collar (17) and the base of the cup, this mechanism is enclosed in the hood (18).

The top and bottom surfaces of the cup are slightly angled to allow complete charge and discharge when the instrument is not perfectly vertical. The cup is ultrasonically welded to the head preventing tampering or adjustment after assembly.

2.2 Legends

The capacity legend, **1/6 gill**, is durably marked on the sight glass. The numbers are a minimum of 5 mm high and the overall height of the fraction is a minimum of 10 mm. The letters are at least 5 mm high.

The manufacturers legend **OPTIC** and the company name and address are on a label around the top of the hood.

The certificate number and the makers name are moulded on to the head.

Additional advertising may be fitted on the head above the top level of the sight glass and does not obscure the sight glass in any way.

2.3 Sealing and stamping

The instrument is ultrasonically welded during manufacture and cannot be dismantled or adjusted. It is therefore not necessary to seal the instrument.

The stamp is applied to a lead seal (19) encasing a knot of nylon thread looped through the body of the instrument.

3 OPERATION

With the instrument fully charged with liquid the operating arm is pushed upwards. The valve land on the standard enters the head and prevents ingress of further liquid, the top 'O' ring of the dispense tube is still in the bore of the cup. Next the rim on the standard operates the air valve allowing access of air during dispense. Continued movement uncovers the cross bore and allows the liquid to dispense, to be replaced by air via the air valve. Maximum movement is achieved when the rim of the standard is in contact with the head, the cross bores are not completely clear of the cup base to allow good drainage. On completion of dispense the operating arm is released, the downward movement operates the sequence in the reverse order. Liquid refills the instrument venting air into the bottle.



Figure 1 Measuring unit

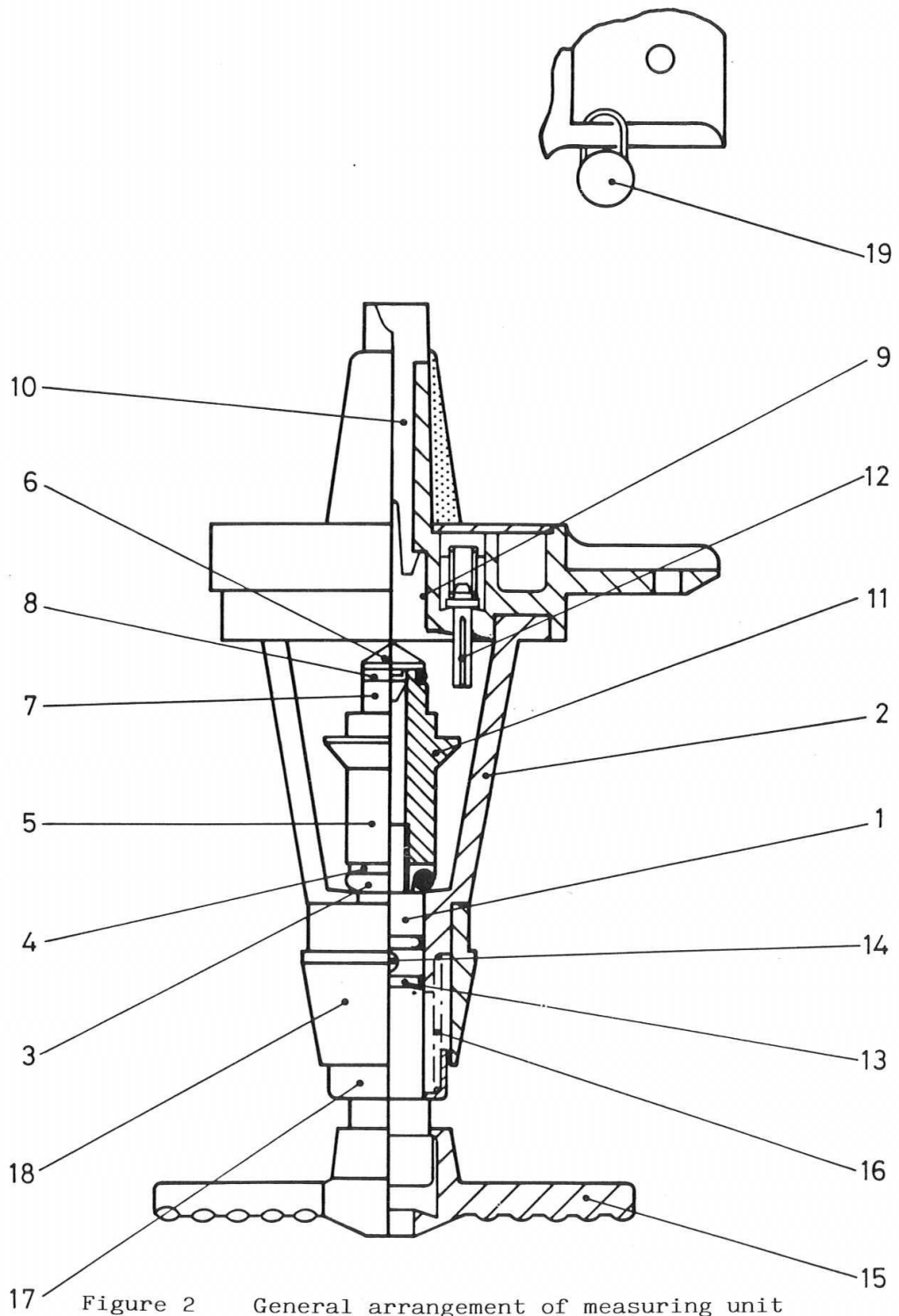

17 Figure 2 General arrangement of measuring unit

Price £3.00 net

ISBN 1 85370 013 4

© Crown Copyright 1988

NATIONAL WEIGHTS AND MEASURES LABORATORY

Department of Trade and Industry

Demand No: 8117267

Printed in the UK for the Department of Trade and Industry

(2016)

dti

WM438

III(2)

CONTINUATION OF CERTIFICATE

Amendment to Certificate

Submitted by: Gaskell and Chambers Ltd
23 Chartwell Drive
Wigston
Leicester
LE8 2FL

Certification No 2016

This approval is extended to include the following authorised alternative:

Hot stamping amendment (amendment No 1 5 June 1989)

Having the stamp achieved by hot stamping onto the side flange of the mounting bracket.

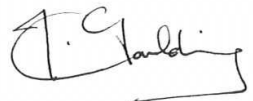

J W Goulding
for Director
National Weights & Measures Laboratory
Department of Trade and Industry
Stanton Avenue
Teddington
Middlesex
TW11 OJZ

Reference No STD 5500

Date 5 June 1989

(2016)



WM443

III(2)

AMENDMENT TO CERTIFICATE

Certification No 2016 (Amendment No 2)

Submitted by: Gaskell and Chambers Ltd
23 Chartwell Drive
Wigston
Leicester
LE8 2FL

Authorisation is hereby given by the Secretary of State for Trade and Industry for the following pattern of a spirit measuring instrument to be amended as described below:

2016

Addition of the following authorised alternatives:

Having capacities of 25 and 50 ml and the quantity legend amended accordingly.

A handwritten signature in black ink, appearing to read 'J W Goulding', is positioned above the typed name of the Director.

J W Goulding

for Director
National Weights and Measures Laboratory
Department of Trade and Industry
Stanton Avenue
Teddington
Middlesex
TW11 0JZ

Reference No: STD 5500

Date: 9 January 1990

(2016)

dti

WM 451

III(2)

AMENDMENT TO CERTIFICATE

Certification No 2016 (Amendment No 3)

Submitted by: Gaskell and Chambers Ltd
23 Chartwell Drive
Wigston
Leicester
LE8 2FL

Authorisation is hereby given by the Secretary of State for Trade and Industry for the following pattern of a spirit measuring instrument to be amended as described below:

2016

Addition of the following authorised alternatives:

Having the option of a plastic delivery tube (item 1).

Reference No: STD 5500
Date: 4 July 1990

GS2016.amd

for G Stones
Director
National Weights and Measures Laboratory
Department of Trade and Industry
Stanton Avenue
Teddington
Middlesex
TW11 0JZ

(2016)

dti

W 17
↓ 54.

III(2)

AMENDMENT TO CERTIFICATE

Certification No 2016 (Amendment No 4)

Submitted by: Gaskill and Chambers Ltd
23 Chartwell Drive
Wigston
Leicester
LE8 2FL

Authorisation is hereby given by the Secretary of State for Trade and Industry for the following pattern of a spirit measuring instrument to be amended as described below:

2016

Addition of the following authorised alternatives:

Having a new design of air valve as illustrated in figure 3.

Reference No: STD 5500
Date: 22 November 1990
ges2016.am4

1/2



G Stones
for Director
National Weights and Measures Laboratory
Department of Trade and Industry
Stanton Avenue
Teddington
Middlesex
TW11 0JZ

CONTINUATION OF CERTIFICATE

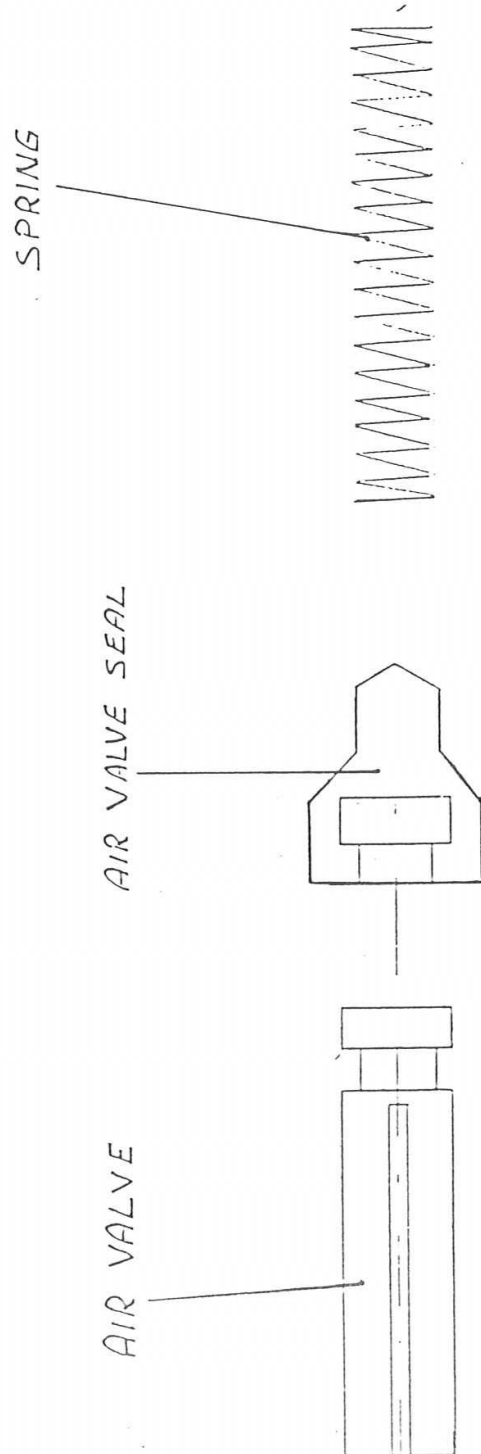

Figure 3 New air valve

(2016)

dti

W7 498

III(2)

AMENDMENT TO CERTIFICATE

Certification No 2016 (Amendment No 5)

Submitted by: **Gaskell and Chambers Ltd**
23 Chartwell Drive
Wigston
Leicester
LE8 2FL

Authorisation is hereby given by the Secretary of State for Trade and Industry for the following certificate of approval relating to a pattern of a spirit measuring instrument to be amended as described below.

2016

Addition of the following authorised alternative:

Having a fixed capacity of 35 ml. The quantity legend is amended accordingly.

✓

Reference No: STD 5500
Date: 27 July 1994
intox\c2016.a5

Signatory: R P Sanders
for Director
National Weights and Measures Laboratory
Department of Trade and Industry
Stanton Avenue
Teddington
Middlesex
TW11 0JZ

1/1

(2016)

dti

W7 Variant from Route
502

III(2)

AMENDMENT TO CERTIFICATE

Certification No 2016 (Amendment No 6)

Submitted by: **Gaskell & Chambers Ltd**
23 Chartwell Drive
Wigston
Leicester
LE18 2FL

Authorisation is hereby given by the Secretary of State for Trade and Industry for the following certificate of approval relating to a pattern of a spirit measuring instrument to be amended as described below:

2016

This Approval is extended to include the addition of the following authorised alternative:-

Having the hood (18) (Figure 2) replaced by a housing which incorporates a non-resettable 5 digit mechanical counting device. The counting mechanism is driven by the spindle collar (17) via a lever within the housing.

G.L.S.

G.L. Snell,

Reference: No STD 5500
Date: 29 November 1994
a_g&c(6).016

Signatory: **G Snell**
for Director
National Weights and Measures Laboratory
Department of Trade and Industry
Stanton Avenue
Teddington
Middlesex
TW11 0JZ

1/1

(2016)

dti

w17 533

VR Book
III(2)

AMENDMENT TO CERTIFICATE

Certification No 2016 (Amendment No 7)

Submitted by: **Gaskell and Chambers Ltd**
23 Chartwell Drive
Wigston
Leicester
LE8 2FL

Authorisation is hereby given by the Secretary of State for Trade and Industry for the following certificate of approval relating to a pattern of a liquid measuring instrument to be amended as described below:

2016

This Approval is extended to include the following authorised alternative:-

Having a silicon rubber 'O-ring' replacing the flat washer seal in the air-valve as illustrated in Figure 4.

Reference No STD 5500
Date 02 June 1997
intox\2016_07.doc

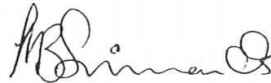
Signatory: M Simmonds
for Director
National Weights and Measures Laboratory
Department of Trade and Industry
Stanton Avenue
Teddington
Middlesex
TW11 0JZ

1/2

(2016)



CONTINUATION OF CERTIFICATE

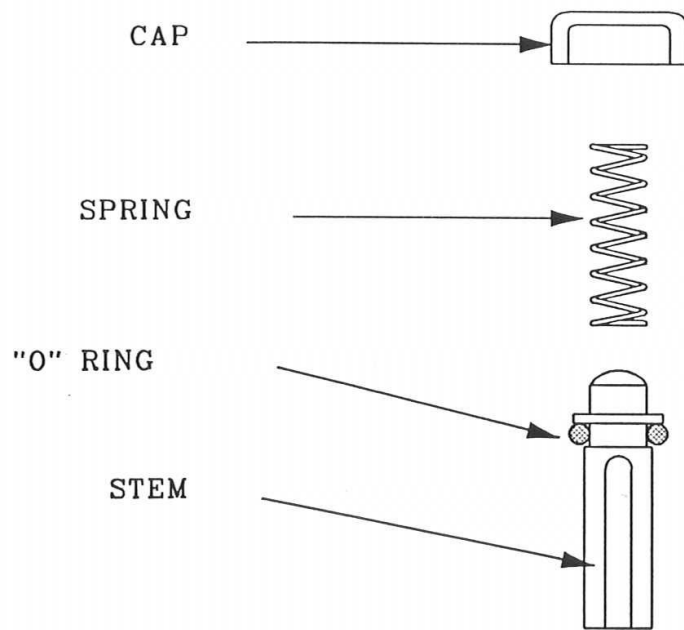

Figure 4 Replacement 'O-ring' on air valve

(2016)

dti

wn 553

III(2)

AMENDMENT TO CERTIFICATE

Certification No 2016 Amendment No 8

Submitted by: **Gaskell and Chambers Ltd**
23-27 Chartwell Drive
Wigston
Leicester
LE18 2FL

Authorisation is hereby given by the Secretary of State for Trade and Industry for the following Certificate of approval relating to a pattern of a spirit measuring instrument to be amended as described below.

2016 Amendment No 8 Capacity legend on both front and rear of the sight glass

Having the capacity legend printed on both the front and rear of the sight glass. This displays the nominal capacity of the measure to the customer when served from the front of the bar from a custom built unit.

Reference No: STD 5500
Date: 17 March 1999
chrism\general\2016-am8

Signatory:

C. S. C. Munteanu

for

C S C Munteanu
Director
National Weights and Measures Laboratory
Department of Trade and Industry
Stanton Avenue
Teddington
Middlesex
TW11 0JZ

1/1

(2016)

dti

W7111 (2)

III(2)

CRB

AMENDMENT TO CERTIFICATE

Certification No 2016 Amendment No 9

Submitted by: **Gaskell & Chambers Ltd**
23-27 Chartwell Drive
Wigston
Leicester
LE18 2FL

Authorisation is hereby given by the Secretary of State for Trade and Industry for the following Certificate of approval relating to a pattern of a spirit measuring instrument to be amended as described below.

2016 Amendment No 9 Alternative lever mechanism

As described in the Certificate but having an alternative lever mechanism as shown in Figure 1. One measure is dispensed when the lever is pushed back fully.

The above is authorised as an amendment to the following Certificate:

2016 Amendment No 9

C.S.C. Munteanu

Signatory: *C S C Munteanu*
for Chief Executive
National Weights & Measures Laboratory
Department of Trade and Industry
Stanton Avenue
Teddington
Middlesex TW11 0JZ
United Kingdom

Reference No: STD 5500

Date: 25 June 2001



Figure 1 Spirit dispenser with alternative lever mechanism

WM 431



(2016)

III(2)

Certificate

Pursuant to section 12 of the Weights and Measures Act 1985

Certification Number 2016/1

Valid Until 5 November 1997

In accordance with the provisions of section 12 of the Weights and Measures Act 1985, the Secretary of State hereby certifies as suitable for use for trade the following pattern of a spirit measuring instrument.

Under the provisions of sub-section 12(6) of the said Act, the validity of this certificate is limited as shown above.

Submitted by: Gaskell and Chambers Ltd
23 Chartwell Drive
Wigston
Leicester
LE8 2FL

Reference No STD 5500

Date 16 August 1988

1/3

for

A handwritten signature in black ink, appearing to read 'A. Thapar'.

A. Thapar
Director
National Weights and Measures Laboratory
Department of Trade and Industry
Stanton Avenue
Teddington
Middlesex
TW11 0JZ



(2016)

CONTINUATION OF CERTIFICATE

2016/1

As described in Certification Number 2016 and any authorised modifications thereof but having the head of the instrument modified by the addition of a plastic adaptor (Figure 1), fitted to the head by three screws, in which case the divider is removed. The adaptor contains a non-return valve to prevent return of any liquid in the instrument when the instrument is inverted, and effects a seal with a pouring device affixed to the bottle.

The Certification Number moulded on the head is 2016/1.

A handwritten signature in black ink, appearing to be the initials 'JA' followed by a flourish.



(2016)
CONTINUATION OF CERTIFICATE

2016/1



Figure 1

WM431



(2016)

III(2)

Certificate

Pursuant to section 12 of the Weights and Measures Act 1985

Certification Number 2016/2

Valid Until 5 November 1997

In accordance with the provisions of section 12 of the Weights and Measures Act 1985, the Secretary of State hereby certifies as suitable for use for trade the following pattern of a spirit measuring instrument.

Under the provisions of sub-section 12(6) of the said Act, the validity of this certificate is limited as shown above.

Submitted by: Gaskell and Chambers Ltd
23 Chartwell Drive
Wigston
Leicester
LE8 2FL

Reference No STD 5500

Date 16 August 1988

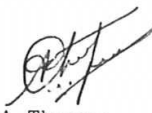
for A Thapar
Director
National Weights and Measures Laboratory
Department of Trade and Industry
Stanton Avenue
Teddington
Middlesex
TW11 0JZ



(2016)

CONTINUATION OF CERTIFICATE

2016/2

As described in Certification Number 2016 and any authorised modifications thereof but the collar is five millimetres longer and contains a magnet which, when the instrument is operated, operates a reed switch in a sensor which is fitted on the instrument mounting bracket and locates in the modified hood (Figure 1). This provides a signal which may only be used to generate management information. The spindle is also five millimetres longer to accommodate the above modification. The tongue of the instrument head is also modified by having a slot to clear a horizontal pin fitted on the mounting bracket. The purpose of the pin is to prevent the use of an instrument which does not give a signal.

The Certification Number moulded on the head is 2016/2. *AW*



(2016)

CONTINUATION OF CERTIFICATE

2016/2

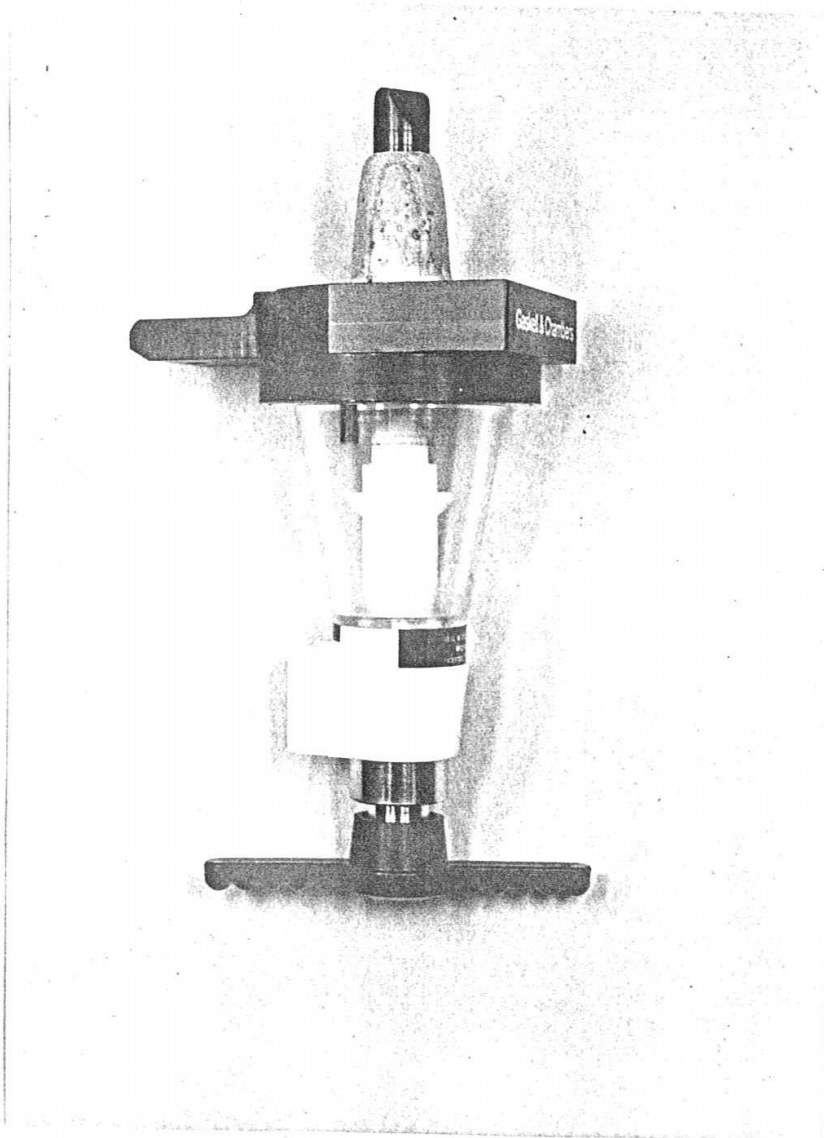

Figure 1

WM 431

Cent Rec



(2016)

III(2)

Certificate

Pursuant to section 12 of the Weights and Measures Act 1985

Certification Number 2016/3

Valid Until 5 November 1997

In accordance with the provisions of section 12 of the Weights and Measures Act 1985, the Secretary of State hereby certifies as suitable for use for trade the following pattern of a spirit measuring instrument.

Under the provisions of sub-section 12(6) of the said Act, the validity of this certificate is limited as shown above.

Submitted by: Gaskell and Chambers Ltd
 23 Chartwell Drive
 Wigston
 Leicester
 LE8 2FL

Reference No STD 5500

Date 16 August 1988

for

A handwritten signature in black ink, appearing to read 'A. Thapar', written over a circular stamp.

A Thapar
Director
National Weights and Measures Laboratory
Department of Trade and Industry
Stanton Avenue
Teddington
Middlesex
TW11 0JZ



(2016)

CONTINUATION OF CERTIFICATE

2016/3

As described in Certification Number 2016 and any authorised modifications thereof but the dimensions of the cup and its internal parts are modified to produce a capacity of a quarter, a fifth or a third of a gill or 5 cl. The top external diameter of the cup, under the joint with the head, in all cases is the same as that in Certification Number 2016, being 45 mm.

The appropriate capacity legend is durably marked on the cup and the Certification Number moulded on the head is 2016/3.

(2016)



CONTINUATION OF CERTIFICATE

2016/4

As described in Certificate Number 2016 and compatible variants thereof but having the head of the instrument modified by the addition of a threaded adaptor (2) for connection to a barrel/keg. The threaded adaptor is manufactured from stainless steel, is fitted through the clearance hole in the cap (3) and is an interference fit into bore of the bodyhead moulding (4). The cap is held in place by the hexagonal section of the adaptor. A short separator (1) is dropped into the adaptor to sit on the top edge. The threaded adaptor screws into a brass outlet fitted to the barrel/keg.

The tongue of the plastic moulding is removed when fitted as a replacement for a 1022 measure.

The threaded section of the adaptor is fitted with a locknut and a fibre washer. The adaptor is screwed into a keg connector and the locknut tightened against the fibre washer to orientate the measure.

The position for hot stamping is moved to the righthand side face of the bodyhead.

The certificate number moulded onto the lefthand side face of the bodyhead is 2016/4.

The instrument is to be mounted vertically, with the barrel/keg lying horizontally in a suitable cradle or stand, as shown in figure 2.

A handwritten signature in black ink, appearing to be 'C. S.' or similar, located below the text.

(2016)

dti

CONTINUATION OF CERTIFICATE

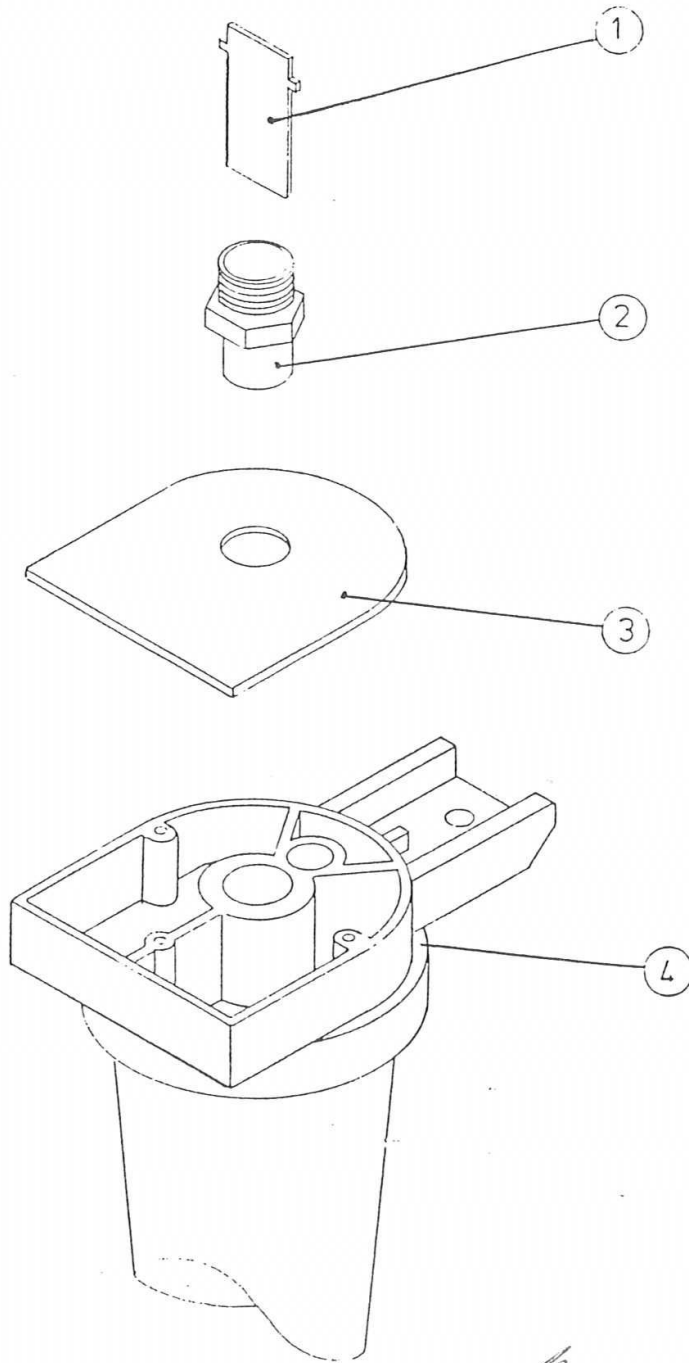

Figure 1 Exploded view

(2016)

dti

CONTINUATION OF CERTIFICATE

2016/4

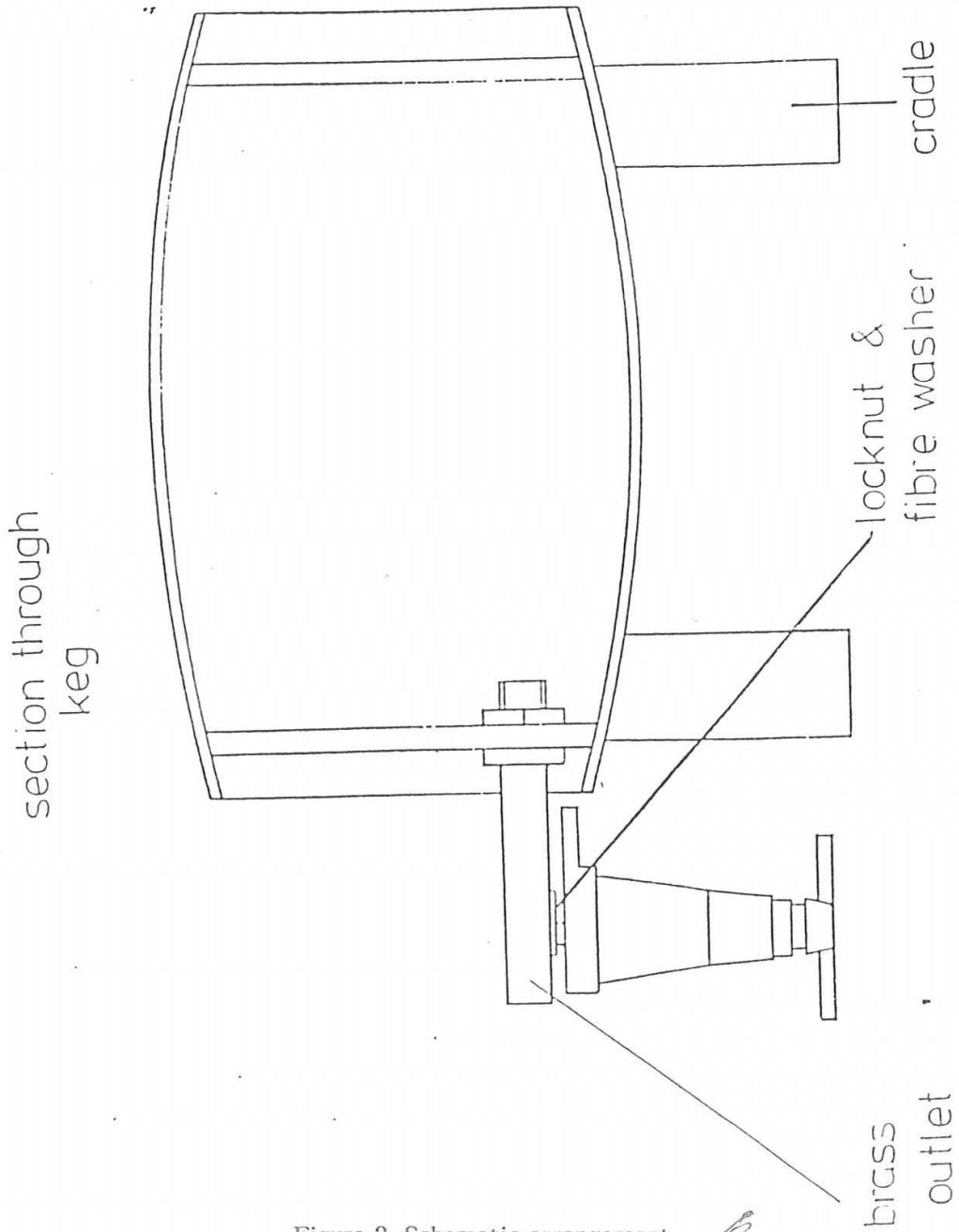

Figure 2—Schematic arrangement

CERTIFICATE HISTORY

CERTIFICATION NO 2016 Amendment No1 Amendment No2 Amendment No3 Amendment No4 Amendment No5 Amendment No6 Amendment No7 Amendment No8 Amendment No9	05 November 1997 05 June 1989 09 January 1990 04 July 1990 22 November 1990 27 July 1994 29 November 1994 02 June 1997 17 March 1999 25 June 1991
CERTIFICATION NO 2016/1	05 November 1997
CERTIFICATION NO 2016/2	05 November 1997
CERTIFICATION NO 2016/3	05 November 1997
CERTIFICATION NO 2016/4	05 November 1997
Renewal of certificate 2016, including amendments 1-9, 2016/1, 2016/2, 2016/3 and 2016/4	17 July 2007 Expiry date extended to 05 November 2017
Revision 1 of certificate 2016, including amendments 1-9, 2016/1, 2016/2, 2016/3 and 2016/4	19 October 2017 Expiry date extended to 18 October 2027