

## Retaining Wall

This invention relates to a retaining wall and to a method of constructing the same.

5

A retaining wall is a structure that holds back soil or rock from a building, structure or area. Retaining walls prevent down-slope movement or erosion and provide support for vertical or near-vertical grade changes. Cofferdams and bulkheads, structures that hold back water, are also considered retaining walls.

10

One type of conventional retaining wall is formed of sheet piling. Sheet pile walls are made out of steel, vinyl, fibreglass, reinforced concrete or plastic sheet piles driven into the ground. Sheet pile walls are typically constructed by driving steel sheets into the ground to permit excavation or filling on one side of the wall. They are considered to be most economical where retention of higher earth pressures of soft soils is required. However, sheet piles can be costly and less adaptable to difficult driving conditions, particularly where boulders or irregular rock surfaces occur in the ground.

15  
20

To cater for difficult driving conditions, sheet piles are often designed for improved drivability rather than to suit the structural requirements of the retaining wall to be formed. This therefore results in a use of sheet piles which is inefficient and not cost effective.

25

Part 5 ("Part 5: Piling") of Eurocode BS EN 1993-5:2007 - Eurocode 3 Design of Steel Structures details sheet piling terminology used in the design of steel structures.

30

According to an aspect of the invention, there is provided a retaining wall for retaining matter on a side thereof comprising:

a plurality of upwardly projecting primary structural members spaced apart from each other and having a first structural property comprising depth installed in a supporting body; and

one or more intermediate panels of material arranged so as to span horizontally the gap between a pair of the primary structural members and thus retain matter between the primary structural members,

wherein the primary structural members are sheet piles, and

wherein the one or more intermediate panels project downwardly into the supporting body to a lesser depth than the primary structural members so as to have a structural property different from the first structural property,

and wherein the one or more intermediate panels are only adequate to retain the matter such that the primary structural members are adapted to provide the main structural restraint to bending and shear in the retaining wall.

~~a plurality of upwardly projecting structural members spaced apart from each other and having first structural properties comprising at least one of: weight; size; strength; and depth to be installed in a supporting body; and one or more intermediate panels of material arranged so as to span horizontally the gap between a pair of primary structural members and thus retain the retained matter between the primary structural members, wherein the primary structural members are sheet piles, and wherein the one or more intermediate panels project downwardly into the supporting body and have second structural properties different from the first structural properties, such that the sheet piles are adapted to provide the main structural restraint to bending and shear in the wall.~~

According to another aspect of the invention, there is provided a method of constructing a retaining wall for retaining matter on a side thereof, wherein the method comprises the steps of: arranging a plurality of primary structural members so that the primary structural members are spaced apart from each other and project downwardly into a supporting body, the primary structural members having a first structural property comprising depth installed in a supporting body; and arranging one or more intermediate panels so as to project downwardly into the supporting body to a lesser depth than the primary

5 | structural members so as to have a structural property different from the first structural property and to span horizontally the gap between a pair of the primary structural members and thus retain matter between the primary structural members, wherein the primary structural members are sheet piles, and wherein the one or more intermediate panels are only adequate to retain the matter such that the primary structural members are adapted to provide the main structural restraint to bending and shear in the retaining wall.

Embodiments of the invention therefore capitalise on the use of (primary) sheet piles which are designed for a primary goal, such as drivability, strength or minimum depth required for overall wall stability, to offset against the structural properties of panels placed between a pair of (primary) sheet piles. In this way, 5 the sheet piles may provide the majority of the structural capacity for the vertical spanning function of the retaining wall. Thus, the intermediate panels need not have the same structural properties as the primary sheet piles. For example, they need not be driven into the supporting ground as far as the primary sheet piles, and may be of lesser weight, size, cost and/or strength. 10 Cost savings can therefore be made in respect of the intermediate panels and the wall may be a more sustainable product.

Taking advantage of surplus structural capacity of the primary sheet piles, for example, embodiments are applicable to forming retaining walls where 15 installation conditions require heavier sections than structurally required for the retaining wall function.

The one or more intermediate panels may bear on or be connected to the pair of primary sheet piles so as to provide improved lateral stability. Such 20 connection may also be adapted so as to provide a water-tight seal between the intermediate panel(s) and the primary sheet piles.

An embodiment may further comprise a stopper or arrester adapted to restrict vertical movement of the one or more intermediate panels at a predetermined 25 position, thereby assisting correct positioning of the intermediate panel(s) when constructing the retaining wall. The stopper/arrester can be located separately from or fixed to either a primary sheet pile or intermediate panel.

An example of the invention will now be described in more detail with reference 30 to the accompanying drawings, in which:

Figure 1 is a front sectional elevation of a retaining wall according to an embodiment of the invention, wherein the section is taken along the line Y-Y of Figure 2; and

Figure 2 is a cross sectional view taken along the line X-X of Figure 1.

5

Referring to Figures 1 and 2, a retaining wall 10 for retaining matter 11 such as soil and/or water on a side thereof is shown. The retaining wall 10 comprises a combination of primary sheet piles 12 spaced apart from each other and intermediate panels 14 spanning the gaps between pairs of primary sheet piles 12.

10

The main structural support to the wall is provided by primary sheet piles 12 which are driven into the sloped surface 16 of the supporting body 18 (in other words, the supporting ground) to a depth "D1". The intermediate panels 14 are driven into the supporting body to a lesser depth "D2" (i.e.  $D1 > D2$ ) and retain at least a portion of the retained matter 11. In other words, the bottom of the one or more intermediate panels is vertically offset with respect to the bottom of the pair of primary sheet piles. It will, however, be understood that "vertically offset" in the context of this invention should be taken to mean being deliberately and knowingly vertically offset as opposed to being offset by a small amount due to construction tolerances when attempting installation at substantially equal depths. That is, "vertically offset" should be understood to not encompass the situation where sheet piles have been intended to be installed at substantially equal depth in a supporting body but, due to construction difficulties and/or tolerances, are slightly vertically offset from each other. For example, in embodiments of the invention, the bottom of the one or more intermediate panels is vertically offset with respect to the bottom of the pair of primary sheet piles example, by more than 10cm, preferably more than 50 cm, and even more preferably more than 1m.

15

20

25

30

The primary sheet piles 12 serve as the primary members for providing structural restraint to bending and shear in the wall, while the intermediate

panels retain matter 11, such as soil and/or water, by spanning horizontally between pairs of primary sheet piles 12.

5 Since they need only be adequate to retain the matter, and not provide the primary structural support of the wall, the intermediate panels 14 are of lesser weight, size and/or strength than the primary sheet piles 12 and are not driven into the supporting ground as far as the primary sheet piles. In the illustrated embodiment, the intermediate panels 14 are of the minimum length required to support the retained material by spanning horizontally between primary panels  
10 or to satisfy other requirements such as water cut-off.

The intermediate panels 14 may be formed from any suitable material including plastic, wood, cloth, concrete, reinforced concrete, and metal, for example. The intermediate panels 14 may also be formed from the same material as the  
15 primary sheet piles 12, in which case the intermediate panels 14 may also be sheet piles 12.

~~Although the intermediate panels 14 are shown to have smaller dimensions than the primary sheet piles 12, they may have the same dimensions as the primary sheet piles but be of different weight and/or strength, for example.~~  
20 Further, although Figures 1 and 2 illustrate the tops of the primary sheet piles 12 and intermediate panels 14 as being flush with each other, they need not be flush with each other in other embodiments.

25 In the illustrated embodiment, the intermediate panels 14 are connected to the primary sheet piles 12 so as to form a seal which prevents or restricts the passage of water through the retaining wall. Further, the intermediate panels 14 are reinforced by structural members (not shown) as required.

30 The retaining wall 10 is constructed by arranging a plurality of primary sheet piles 12 to be spaced apart from each other and project downwardly into the supporting ground. One or more intermediate panels 14 are arranged so as to span the gap between a pair of primary sheet piles 12 and to retain at least a

portion of the retained matter 11. In doing so, the intermediate panels 14 are also arranged to project downwardly into the supporting ground to a lesser extent than the pair of primary sheet piles.

- 5 The intermediate panels 14 may be driven or pushed into place separately or may be secured to the primary sheet piles 12 and installed together with the primary sheet piles 12.

To assist in alignment, an embodiment may be installed using temporary longer secondary panels which may either: (a) consist of two sections releasably  
10 connected together to form a temporary longer panel which is later partially withdrawn and the top section released from the bottom section; or (b) comprise a longer panel which is subsequently withdrawn fully and replaced with shorter/smaller intermediate panel.

15

Stopper or arresting apparatus can be used on the primary pile sheets, the intermediate panels, and/or the supporting body to restrict vertical movement of the intermediate panels at a required level and assist their correct location.

20 Embodiments may be particularly suited to applications such as motorway widening on embankments where relatively large and/or long sheet piles may be required to retain a low height of ground. In such situations, the sheet piles are typically sized for drivability rather than to suit the retaining wall structural requirements. The sheet piles therefore have considerable surplus structural  
25 capacity which can be traded off against the structural properties of the intermediate panels 12 which enable cost savings to be made, for example.

While specific embodiments have been described herein for purposes of illustration, various modifications will be apparent to a person skilled in the art  
30 and may be made without departing from the scope of the invention.

For example, embodiments may be implemented in cantilever or anchored retaining wall application, and the intermediate panels may be of an arched form to operate either in tension or compression to retain matter.

- 5 Also, intermediate panels may be of greater width than the gap between a pair of spaced apart sheet piling. In such embodiments, the panel(s) may not connect to sheet piling but instead simply slot behind/in-front so that they bear on a side of the sheet piling.



Claims

1. A retaining wall for retaining matter on a side thereof comprising:  
a plurality of upwardly projecting primary structural members spaced  
5 apart from each other and having a first structural property comprising depth  
installed in a supporting body; and  
one or more intermediate panels of material arranged so as to span  
horizontally the gap between a pair of the primary structural members and thus  
retain matter between the primary structural members,  
10 wherein the primary structural members are sheet piles, and  
wherein the one or more intermediate panels project downwardly into  
the supporting body to a lesser depth than the primary structural members so  
as to have a structural property different from the first structural property,  
and wherein the one or more intermediate panels are only adequate to  
15 retain the matter such that the primary structural members are adapted to  
provide the main structural restraint to bending and shear in the retaining wall.
2. A retaining wall as claimed in claim 1, wherein the one or more  
intermediate panels of material comprise at least one of: a secondary sheet  
20 pile, a flexible sheet adapted to be driven into the supporting body, and a panel  
of rigid material.
3. A retaining wall as claimed in any preceding claim, wherein the one or  
more intermediate panels are connected to the pair of primary structural  
25 members.
4. A retaining wall as claimed in any preceding claim, wherein the one or  
more intermediate panels comprise at least two panels of material connected to  
each other.  
30
5. A retaining wall as claimed in any preceding claim, further comprising a  
stopper adapted to restrict vertical movement of the one or more intermediate  
panels at a predetermined position.

6. A method of constructing a retaining wall for retaining matter on a side thereof, wherein the method comprises the steps of:

5 arranging a plurality of primary structural members so that the primary structural members are spaced apart from each other and project downwardly into a supporting body, the primary structural members having a first structural property comprising depth installed in a supporting body; and

10 arranging one or more intermediate panels so as to project downwardly into the supporting body to a lesser depth than the primary structural members so as to have a structural property different from the first structural property and to span horizontally the gap between a pair of the primary structural members and thus retain matter between the primary structural members,

wherein the primary structural members are sheet piles, and

15 wherein the one or more intermediate panels are only adequate to retain the matter such that the primary structural members are adapted to provide the main structural restraint to bending and shear in the retaining wall.

7. A method as claimed in claim 6, further comprising the step of connecting the one or more intermediate panels to the pair of primary structural members.

20

8. A retaining wall substantially as described hereinabove with reference to the accompanying figures.

25 9. A method of constructing a retaining wall substantially as described hereinabove with reference to the accompanying figures.

AbstractRetaining Wall

A retaining wall for retaining matter on a side thereof comprising: a plurality of  
5 upwardly projecting primary sheet piles spaced apart from each other and  
having first structural properties comprising at least one of weight, size,  
strength and depth to be installed in a supporting body; and one or more  
intermediate panels of material arranged so as to span the gap between a pair  
of primary sheet piles and to retain at least a portion of the retained matter,  
10 wherein the one or more intermediate panels have second structural properties  
different from the first structural properties.

[Figure 1]

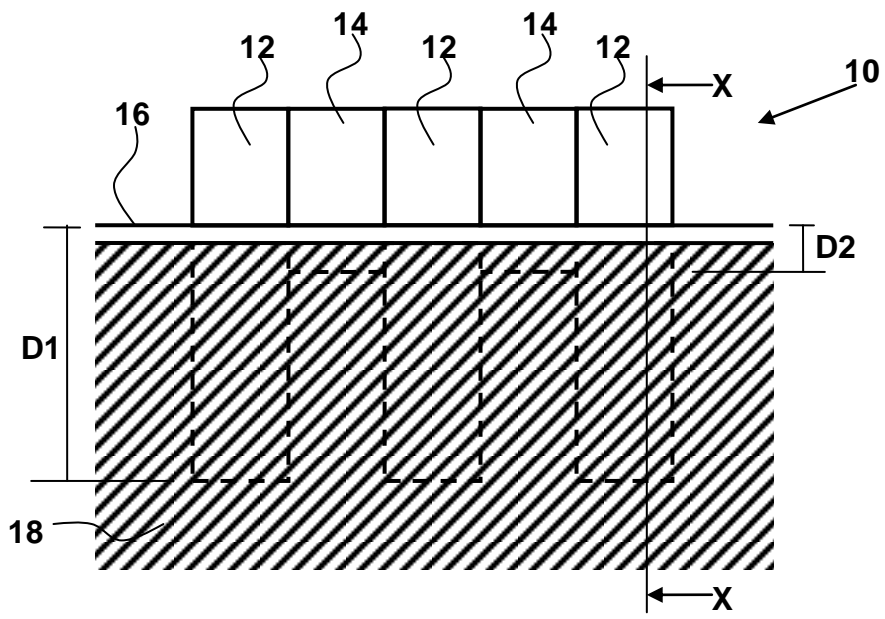

Figure 1

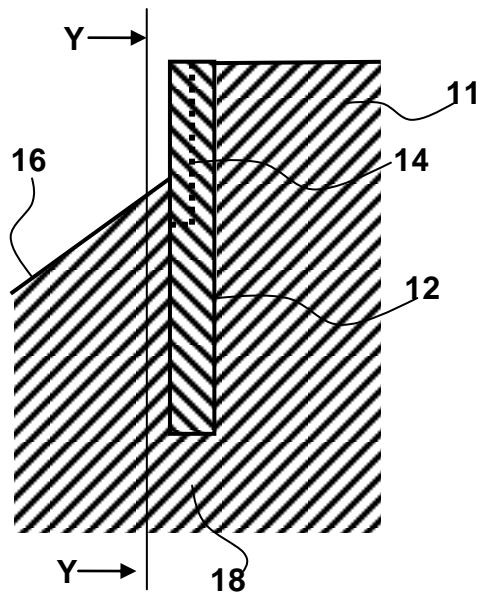

Figure 2