



# Minimum Requirements for the Self-Monitoring of Flow

Environment Agency  
Version 4.0  
August 2014





## Foreword

We set up our Monitoring Certification Scheme (MCERTS) to provide a framework of standards you can use to monitor things that affect the environment. MCERTS covers:

- the standards of performance that your monitoring equipment must meet
- the level your staff must be qualified to
- accrediting laboratories and on-site inspections in line with European and international standards.

This standard sets out what you must do if you monitor liquid flow. The standard applies to you if you have a permit under the Environmental Permitting Regulations, which says you must:

- monitor liquid flow (for example, sewage or trade effluent)
- collect and bring together that information

If your permit says that you must monitor liquid flow, you must have your flow monitoring arrangements independently assessed against this standard. Any exceptions to this requirement will be specified within your permit. An MCERTS Inspector must carry out this assessment. The Inspector must have met the conditions of the 'Competency standard for MCERTS Inspectors and Assistant Inspectors –flow monitoring'. The supporting management system must also be assessed by an MCERTS management system auditor. Sira Certification Service runs this scheme on our behalf.

The arrangements you use to monitor flow must be accurate. The level of accuracy is specified by us, depending on the application.

### The benefits of this standard

- The standard makes sure that you, the public and other organisations can be confident that the information you provide is reliable
- Everybody in the competitive market of measuring liquid flow will be working towards meeting the same standard
- The standard sends a message that measuring liquid flow is an important part of producing reliable information for regulatory purposes
- By setting quality standards which everybody must work towards, the standard promotes and raises the professional reputation of staff and organisations involved in measuring liquid flow

If you meet the standard, Sira will issue you with a certificate on our behalf.

If you have any questions about the scheme, please contact:

Steven Saxbee  
**Sira Certification Service**  
12 Acorn Industrial Park  
Crayford Road  
Crayford, Kent  
DA1 4AL

Phone: 01322 520500

email: [mcerts@siracertification.com](mailto:mcerts@siracertification.com)

You can get more information on MCERTS, including the standards related to monitoring flow, from our website at [www.mcerts.net](http://www.mcerts.net)

If you have any general questions about MCERTS, please contact:

Environment Agency  
email: [andrew.chappell@environment-agency.gov.uk](mailto:andrew.chappell@environment-agency.gov.uk)  
Phone: 0118 953 5332

# Minimum Requirements for the Self-Monitoring of Flow

## Contents

<b>1</b>	<b>Introduction</b>	<b>1</b>
<b>2</b>	<b>Outline of the scheme</b>	<b>1</b>
	2.1 Operation	1
	2.2 The inspection process	2
	2.3 Failed site requirements	3
	2.4 Failed management system requirements	3
	2.5 Dispensations	3
<b>3</b>	<b>Flow-monitoring installations</b>	<b>4</b>
	3.1 Flow monitoring	4
	3.2 Site performance requirements	4
	3.3 The role of MCERTS Inspectors & Assistant Inspectors	6
	3.4 Conformance assessment	6
<b>4</b>	<b>Management system</b>	<b>7</b>
	4.1 Introduction	7
	4.2 Management system	8
	4.3 Possible extension of MCERTS	8
	4.4 Quality/environmental policy	8
	4.5 Management responsibilities	9
	4.6 Documentation	9
	4.7 Operating procedures	9
	4.8 Document control	9
	4.9 Equipment inventory	10
	4.10 Maintenance	10
	4.11 Commissioning	10
	4.12 Site Changes	10
	4.13 Verification	10
	4.14 Data treatment	11
	4.15 Corrective actions	11
	4.16 Internal audits	11
	4.17 Conformance assessment – management system	11
<b>5</b>	<b>Recertification</b>	<b>12</b>
<b>6</b>	<b>Status of this document</b>	<b>12</b>
<b>Appendix 1</b>	<b>Estimating the uncertainty</b>	
<b>Appendix 2</b>	<b>Open channel flow measurement system concessions</b>	
<b>Appendix 3</b>	<b>Electromagnetic flowmeters for liquid flow in pipes</b>	
<b>Appendix 4</b>	<b>Installation and use of air firing ultrasonic level sensors for open channel flow measurement</b>	

## Record of amendments

There have been a significant number of updates throughout the standard. This record of amendments only identifies the most major changes.

Version	Date	Amendment
3.4	Mar 12	Whole document: References to BS3680 replaced with appropriate ISO Standards references
3.4	Mar 12	Section 2.5.6: New section - clarification of the requirement for the management system audit if dispensation granted.
3.4	Mar 12	Section 3.1.2: Text clarified regarding requirement to use flowmeters certified under MCERTS for new and replacement installations.
3.4	Mar 12	Section 3.4.1: Text moved to (new) 3.4.3
3.4	Mar 12	Section 3.4.6: Terminology revised to commonly used term "calibration reference plate"
3.4	Mar 12	Section 3.4.7: New requirement for MCERTS inspector to check local display
3.4	Mar 12	Section 3.4: Clause numbering revised to take account of new paragraphs
3.4	Mar 12	Section 5.2: clarification for the need to re-assess the management system
3.4	Mar 12	Appendix 2 Section A2.7 Text on baffles moved to new paragraph A2.8
3.4	Mar 12	Appendix 2 Section A2.8 New paragraph regarding use of baffles and flow straighteners
3.4	Mar 12	Appendix 2: Secondary device table. Requirement for sensor position on weirs updated to reflect current ISO Standard and note added regarding systems designed under previous BS Standard
3.4	Mar 12	Appendix 3: Clarification throughout.
3.5	Feb 13	Changed contact details for Sira
3.5	Feb 13	Section 3.2.2: Qmax up to 9x DWF acceptable
3.5	Feb 13	Change to section 4.3
3.5	Feb 13	Appendix 3.22 More emphasis on access to electromagnetic flow meters for cleaning
3.5	Feb 13	New Appendix 4: Installation and use of air firing level sensors for open channel flow measurement
4.0	Aug 14	changes to make the scheme suitable for "self monitoring of flow" for any flow measurement
4.0	Aug 14	3.1.4 definition of 'continuous flow monitoring' added
4.0	Aug 14	3.2 amended to distinguish between effluent flow monitoring (3.2.1) and instantaneous flow monitoring (3.2.2)
4.0	Aug 14	3.2.1 includes contents of Bulletin 18 "Sites with multiple discharges"
4.0	Aug 14	3.2.2 & A1.2.1 target measurement uncertainty included for instantaneous flow
4.0	Aug 14	3.1.2 & A4.3 flowmeters "hold" (not "maintain") product certification under the MCERTS standard
4.0	Aug 14	3.4.9 inspection reports shall include a flow/uncertainty table and/or curve which can be used to estimate measurement uncertainty at specific flowrates
4.0	Aug 14	Appendix 1 redrafted 'Estimating the uncertainty' for effluent flow monitoring, instantaneous flow monitoring and for pumped or batch flows
4.0	Aug 14	'MCERTS Site Conformity Inspection Certificate' changed to 'MCERTS Inspection Certificate'
4.0	Aug 14	3.2.1 Last paragraph added for combining uncertainties for multiple meters on one discharge
4.0	Aug 14	Clarification of requirements relating to Quality/environmental policy (4.4), Management responsibilities (4.5), Documentation (4.6), Operating procedures (4.7), Commissioning (4.11), Site Changes (4.12), Verification (4.13) and Corrective actions (4.15)
4.0	Aug 14	Appendix 3, Table 2 – Reverse flow uncertainty, example and additional guidance provided

# Minimum Requirements for the Self-Monitoring of Flow

## 1 Introduction

1.1 This MCERTS standard specifies the Environment Agency's minimum requirements for the self-monitoring of flow. This standard covers:

- performance requirements for flow-metering installations in terms of a target measurement uncertainty
- management system requirements to ensure the ongoing performance of flow metering installations

1.2 Conformance with this MCERTS standard is based on assessment of the flow-monitoring arrangements by MCERTS Inspectors and assessment of the supporting management system by MCERTS management system auditors. MCERTS Inspection Certificates are issued to Operators (Permit Holders regulated under the Environmental Permitting Regulations - EPR) following satisfactory assessment against this standard.

1.3 This standard currently applies to:

- Sites with permits issued under the Environmental Permitting Regulations (EPR) including:
  - industrial sites previously regulated under the Pollution Prevention and Control Regulations
  - Water Utility sewage treatment works previously regulated under the Water Resources Act
  - other sites with permits transferred to EPR if the flow monitoring arrangements are significantly changed
  - new installations with permits issued under EPR
- Sites falling under the Urban Wastewater Treatment Directive (UWWTD) (91/271/EEC and 98/15/EEC).
- Sites with permits issued under the Radioactive Substance Regulations.

1.4 This standard has prescriptive elements primarily based on recognised BS, EN and ISO Standards, supported by the professional judgement exercised by MCERTS Inspectors during their inspection of the flow-monitoring arrangements.

## 2 Outline of the scheme

### 2.1 Operation

2.1.1 Sira operates the scheme on behalf of the Environment Agency. Sira also provides bulletins (additional detailed procedures and guidance) which are available at [www.siraenvironmental.com/mcerts](http://www.siraenvironmental.com/mcerts).

2.1.2 MCERTS Inspectors are assessed and appointed by Sira in accordance with the MCERTS Standard: *Competency Standard for MCERTS Inspectors & Assistant*

*Inspectors –flow monitoring.* Contact details for MCERTS Inspectors are available at [www.siraenvironmental.com/mcerts](http://www.siraenvironmental.com/mcerts).

2.1.3 MCERTS Inspectors assess flow monitoring arrangements in accordance with this MCERTS Standard: *Minimum Requirements for the Self-monitoring of Flow*.

2.1.4 MCERTS management system auditors conduct an assessment of the management system relating to the Operators flow monitoring arrangements in accordance with this MCERTS Standard: *Minimum Requirements for the Self-monitoring of Flow*.

## **2.2 The inspection process**

### **2.2.1 Site Inspection and management system audit**

The Operator chooses an MCERTS Inspector from the list of Service Providers maintained on the Sira web site.

The MCERTS Inspector undertakes an inspection of the site process configuration/flow monitoring arrangements and prepares an Inspection Report. The MCERTS Inspector provides the Operator with a copy of the Inspection Report.

The MCERTS Inspector shall use on-site and other evidence to ensure that the flow monitoring installation is being satisfactorily maintained. Installations with, for example, restricted access shall have specific maintenance procedures detailing how maintenance can be carried out. An MCERTS Inspection Certificate cannot be issued unless there is evidence that the installation is being maintained.

The MCERTS management system auditor conducts an assessment of the management system requirements relating to flow monitoring and produces an audit report.

### **2.2.2 Application for certification**

Provided that the MCERTS requirements are met, the Operator makes an application to Sira for an MCERTS Inspection Certificate. The MCERTS Inspector may make the application on behalf of the Operator.

The application must include the MCERTS Inspection Report, the MCERTS management system audit report and the appropriate fee.

### **2.2.3 Review and certificate issue**

Sira reviews the evidence included in the application. Provided that the MCERTS requirements are met, Sira issues an MCERTS Inspection Certificate to the Operator. MCERTS Inspection Certificates are valid for five years from the date of the initial site inspection.

### **2.2.4 Surveillance and reassessment of the management system**

In order to maintain certification throughout the certification period, the Operator's management system shall be subjected to periodic surveillance. The first surveillance visit will be conducted approximately 12 months after the initial assessment. Thereafter, the frequency of surveillance will be agreed with the Operator, based on the audit findings. Re-assessment of the management system is conducted every five years.



## **2.3 Failed site requirements**

- 2.3.1 If a site fails to meet the MCERTS site requirements, remedial work shall be carried out. The MCERTS Inspector shall provide guidance on the remedial work required to bring the site into conformity with MCERTS requirements.
- 2.3.2 On completion of the remedial work, the MCERTS Inspector conducts a re-inspection to confirm that the site is now in conformity with MCERTS requirements.
- 2.3.3 Provided that the MCERTS requirements are met, the MCERTS Inspector provides the Operator with an MCERTS Inspection report confirming that the site now meets the MCERTS requirements.
- 2.3.4 The Operator can then apply to Sira for an MCERTS Inspection Certificate.

## **2.4 Failed management system requirements**

- 2.4.1 Where significant deficiencies are identified in the Operator's management system, these will be recorded and presented to the Operator during audit. The Operator will be given an opportunity to address the deficiencies and provide evidence of corrective action. Further audits may be required to collect evidence that the deficiencies have been resolved.
- 2.4.2 Provided that the MCERTS management system requirements are met, the auditor provides the Operator with a report confirming that it now meets the MCERTS requirements.
- 2.4.3 The Operator is then able to apply to Sira for an MCERTS Inspection Certificate.

## **2.5 Dispensations**

- 2.5.1 A site may fail to comply with MCERTS requirements in a relatively minor way but the cost of immediate rectification is high. In these exceptional cases an application can be made to the Environment Agency for a dispensation. This will require a cost/benefit business case to be produced. A copy of the (non-compliant) MCERTS Inspection report shall be included with the application for a dispensation. The report shall confirm why the site does not meet the MCERTS requirements, the likely effect of the deficiency on the flow records and include details of the suggested remedial work required to remedy the situation.
- 2.5.2 Provided that the Environment Agency agrees with the submission the Operator will be issued with a dispensation for the site in question. The dispensation will include a reference to the (non-compliant) MCERTS Inspection report. The Environment Agency may also wish to discuss the matter with the MCERTS Inspector to clarify any points prior to making a decision.
- 2.5.3 The Operator then makes an application to Sira which shall include the (non-compliant) MCERTS Inspection report, a copy of the dispensation issued by the Environment Agency, evidence that the MCERTS management system requirements have been met and the fee.
- 2.5.4 On receipt of the application, Sira will review the evidence submitted and issue an MCERTS Inspection Certificate valid for 5 years from the date of the site inspection. The Inspection Certificate will contain a reference to the dispensation.

- 2.5.5 Dispensations are not a permanent provision and it is expected that Operators will need to resolve the problem as soon as reasonably practicable. If a dispensation needs to be extended at the first recertification then the Operator needs to re-justify the need, including an explanation as to why it has not been resolved in the preceding five years. Normally, only one extension of a dispensation will be allowed.
- 2.5.6 Where a dispensation is granted, the operator is still required to maintain a management system (section 4.2). The management system shall be subject to periodic surveillance.

### **3 Flow monitoring installations**

#### **3.1 Flow monitoring**

- 3.1.1 The Environment Agency may include conditions in a permit requiring the Operator to measure volume and/or flow-rate.
- 3.1.2 The Environment Agency allows Operators to select the flow measurement system that they believe is best suited to their operations. However, any new or replacement flowmeters<sup>1</sup> shall hold product certification under the MCERTS standard: *Performance Standards and Test Procedures for Continuous Water Monitoring Equipment - Part 3*. This standard is available at [www.mcerts.net](http://www.mcerts.net). An exception can only be made if there is no suitable MCERTS certified product available for the specific installation and it is agreed in writing by the Environment Agency. A list of MCERTS certified products can be found at [www.siraenvironmental.com/mcerts/product.aspx](http://www.siraenvironmental.com/mcerts/product.aspx)
- 3.1.3 The Environment Agency will require the Operator to record flow data and make returns as specified in their permit or the Environment Agency's Flow Policy. Flow measurement may be carried out at any location that is appropriate to measure the required flow.
- 3.1.4 Continuous flow monitoring refers to a flow-rate measurement which comprises of spot flow measurements or an average rate of flow over a period of 15 minutes or less depending on site specific requirements.

#### **3.2 Site performance requirements**

##### **3.2.1 Effluent flow monitoring**

For effluent flow monitoring, the total daily volume of the discharge specified in the permit shall be measured with a target uncertainty of  $\pm 8\%$  (or better) at a confidence level of 95%, calculated as detailed in Appendix 1.

The location of the flow-monitoring installation shall ensure representative measurement of the total flow. For those sites that treat all incoming flows, rather than divert high flows to storm overflows, and have a dry weather flow limit in their permit, the Environment Agency will accept up to 9 x DWF as the monitoring limit.

---

<sup>1</sup> For the purposes of this standard, a flowmeter is an instrument which measures the flow-rate or totalised volume of fluid passing along a pipe or channel, or computes such quantities from measurements of one or more properties which have a defined relationship with the flow-rate.

Some permits specify more than one location for discharges from a site with specific limits and monitoring requirements for each location. Therefore, flow measurement will often be required for each separate process operated on the site.

For example, a power station may have a large cooling water discharge and a smaller discharge for an effluent treatment plant. Where flow monitoring requirements are specified in the permit for each of these discharges, they will be measured separately and will be inspected separately. The discharge points will be listed on the Inspection Certificate

The MCERTS Inspection report shall include details of all the discharge flow monitoring arrangements on site where these are included in the permit.

Each discharge included on the permit shall meet the  $\pm 8\%$  target uncertainty.

The target uncertainty of  $\pm 8\%$  therefore applies to **each** emission point and **not** to the sum of all the emission points.

However where the flow from a single discharge is measured by combining the readings from more than one flowmeter, all the relevant flowmeters shall be inspected and their individual uncertainties combined to obtain the uncertainty for the discharge measurement.

### 3.2.2 **Instantaneous flow monitoring**

Instantaneous flow refers to a flow-rate measurement which may comprise a spot reading or an average rate of flow over a period of 15 minutes or less depending on site-specific requirements.

Where the Environment Agency includes conditions in a permit requiring the Operator to measure instantaneous flow to full treatment or the pass forward flow at a pumping station the flow shall be measured with a target uncertainty of  $\pm 8\%$  (or better) at the flow rate specified in the permit.

Where the Environment Agency includes conditions in a permit requiring the Operator to measure the instantaneous flow of an intermittent discharge the flow shall be measured to a target uncertainty of  $\pm 8\%$  (or better) at 25% of the design flow rate. The design flow rate shall be agreed with the Environment Agency.

Where the Environment Agency includes conditions in a permit requiring the Operator to measure the instantaneous flow through a disinfection process, for the purpose of controlling the disinfecting dose, the flow shall be measured to a target uncertainty of  $\pm 8\%$  (or better) at 25% of the design flow rate. The design flow rate shall be agreed with the Environment Agency. Any exception to these requirements will be confirmed in writing by the Environment Agency.

### **3.3 The role of MCERTS Inspectors and Assistant Inspectors**

- 3.3.1 An MCERTS Inspector is a technical specialist who can demonstrate considerable experience and expertise in assessment of flow monitoring arrangements. A key role of the MCERTS Inspector is to exercise professional judgement. An MCERTS Inspector is able to assess potential effects of deviations in flow monitoring arrangements and estimate these as part of an uncertainty calculation. An MCERTS Inspector can work in isolation or may supervise the work of others.
- 3.3.2 The competency requirements for MCERTS Inspectors and Assistant Inspectors and the duties that they may perform are specified in *Competency Standard for MCERTS Inspectors and Assistant Inspectors –flow monitoring (section 3)*. This can be found at: [www.mcerts.net](http://www.mcerts.net).
- 3.3.3 An Assistant Inspector has specific technical expertise, primarily in obtaining dimensional measurements of flow monitoring structures and/or site process configuration. They will have the necessary competence to undertake these measurements unsupervised. Data and information recorded by an Assistant Inspector must be quality checked and controlled by an MCERTS Inspector. Any subsequent professional judgement must be applied by the MCERTS Inspector.
- 3.3.4 It is not acceptable for an MCERTS Inspector to simply conduct a desk review of an inspection carried out by an Assistant Inspector. The MCERTS Inspector must visit the site.
- 3.3.5 Individuals, for example MCERTS trainees, not appointed as MCERTS Inspectors or Assistant Inspectors, must be accompanied and supervised by an MCERTS Inspector.

### **3.4 Conformance assessment**

- 3.4.1 The MCERTS Inspector shall establish that the primary and secondary installation, their installation and ongoing operation (for example, flume/weir plus level measuring devices) are fit for purpose. If flowmeters hold product certification under the MCERTS standard: Performance Standards and Test Procedures for Continuous Water Monitoring Equipment - Part 3, they shall be regarded as fit for purpose. Nevertheless, the requirements of this MCERTS standard shall apply to their installation and ongoing operation.
- 3.4.2 The MCERTS Inspector shall assess conformance by using recognised Standards and by using their professional judgement. Appendix 2 provides guidance on “concessions” from International Standards for open channel flow structures. Appendix 3 provides guidance on the uncertainties that can be found on installations using electromagnetic flowmeters. The MCERTS Inspector shall provide written justification if, in his/her opinion, target uncertainty will still be achieved despite concessions outlined in Appendix 2 being exceeded.
- 3.4.3 The MCERTS Inspector shall assess the suitability of the flow monitoring installation by site inspection and examination of flow diagrams. The MCERTS Inspector shall ensure that any flow diagrams provided are representative and accurate. The site inspection shall include a full walking audit of the site to establish the process routes for all relevant inflows, overflows, re-circulation and process returns.

- 3.4.4 The MCERTS Inspector shall assess the location of the measurement structure and the impact of hydraulic influences both upstream and downstream to cover the full range of flow conditions.
- 3.4.5 The MCERTS Inspector shall confirm the adequacy of site maintenance arrangements. Any evidence of inadequate maintenance shall be recorded in the Inspection report for subsequent investigation during the management system assessment. An MCERTS Inspection Certificate cannot be issued unless there is evidence that the installation is being satisfactorily maintained.
- 3.4.6 The MCERTS Inspector shall carry out calibration/set up checks on the measuring instruments. These checks shall record the set up programme of the measurement instrument to include the zero set up, calibration reference plate setting, calculation method, programmed dimensions, range etc.
- 3.4.7 The MCERTS Inspector shall confirm that any local display is in agreement with the flowmeter output.
- 3.4.8 The MCERTS Inspector shall record conformance with the requirements of this standard. The information gathered during the inspection shall be used to assess the suitability and uncertainty of the flow measurement installation, which is to be included in the inspection report and forwarded to Sira.
- 3.4.9 The inspection report shall include a flow/uncertainty table and/or curve which provides the relationship between flow and uncertainty over the operational range of the flowmeter. For those sites monitoring effluent flow this is used together with dry weather flow data, to calculate the uncertainty in total daily volume as detailed in Appendix 1. An estimate of measurement uncertainty at specific flowrates can also be derived from the flow/uncertainty table and/or curve.
- 3.4.10 Sira will only issue an MCERTS Inspection Certificate if all relevant requirements of the MCERTS standard have been met. The MCERTS Inspection Certificate shall be dated to coincide with the date of inspection of the flow monitoring arrangements.

## **4 Management system**

### **4.1 Introduction**

- 4.1.1 The Operator shall establish and maintain a management system for its flow monitoring arrangements, to ensure that the performance requirements specified in Section 3.2 are met at all times. Detailed guidance covering each of the management system requirements is available from Sira at [www.siraenvironmental.com/mcerts](http://www.siraenvironmental.com/mcerts)
- 4.1.2 Figure 1 shows a typical schematic of a typical open channel flow measurement system whereby data are sent remotely to a centralised location. It indicates the division of responsibility for assessment of the two key areas i.e. site process configuration/flow measurement system and the management system. The site process configuration, primary device and secondary device are the subject of a site assessment. Data acquisition and telemetry are assessed by auditing the Operator's management system.

**Figure 1 – Schematic of a flow measurement system**

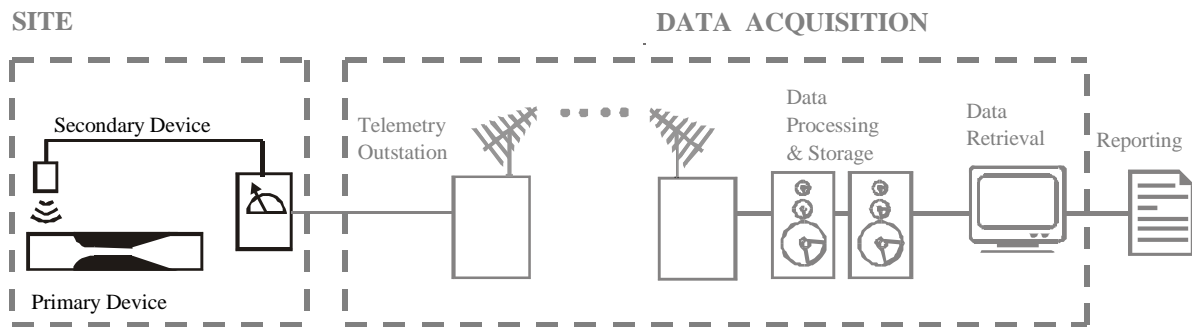

## 4.2 Management System

4.2.1 The management system shall include statements, information and documentation, as appropriate, covering:

- quality/environmental policy – section 4.4
- management responsibilities – section 4.5
- documentation – section 4.6
- operating procedures – section 4.7
- document control – section 4.8
- equipment inventory – section 4.9
- maintenance – section 4.10
- commissioning – section 4.11
- site changes – section 4.12
- verification – section 4.13
- data treatment – section 4.14
- corrective actions – section 4.15
- internal audit section – 4.16.

## 4.3 Possible extension of MCERTS

4.3.1 In the future, as MCERTS is extended, a simplified management system may be considered.

## 4.4 Quality/environmental policy

4.4.1 The Operator shall establish and maintain a documented quality/environmental policy. The policy shall be issued under the authority of top management. A policy statement in compliance with the requirements of ISO 14001 that includes a commitment to comply with applicable legal requirements shall be considered to meet this requirement.

4.4.2 Those responsible for MCERTS related operations shall be made aware of the policy.

## **4.5 Management responsibilities**

- 4.5.1 The Operator shall ensure that responsibilities and authorities with respect to MCERTS are defined and communicated to all relevant personnel. Designated personnel, irrespective of other responsibilities, shall have responsibility and authority for:
- ensuring MCERTS management system procedures are established, implemented and maintained
  - reporting to top management, and liaising with Sira and the Environment Agency on the performance of the flow-monitoring arrangements, including the management system and the need for any improvements
  - ensuring the requirements of the management system in relation to meeting the performance targets are communicated and understood
- 4.5.2 The Operator shall ensure that persons with MCERTS responsibilities receive appropriate training, are competent and that appropriate records and documentation (4.6) are maintained. Internal training and self-study may be acceptable but records shall be retained providing details of the training received.
- 4.5.3 The Operator shall maintain organisational charts and job descriptions of staff involved in flow monitoring. Job descriptions shall include job title, description of duties, responsibilities, qualifications, training and experience requirements.

## **4.6 Documentation**

- 4.6.1 Management system documentation shall include the following:
- the quality/environmental policy referred to in 4.4.1
  - an overview of the MCERTS management system and the flow monitoring arrangements
  - operating procedures
- 4.6.2 The current version of this MCERTS standard shall be accessible

## **4.7 Operating procedures**

- 4.7.1 The Operator shall establish and maintain procedures and instructions as required by this MCERTS standard. Operating procedures can be in any form or type of media and should be no more detailed than is required by the complexity of the organisation or the flow monitoring arrangements.

## **4.8 Document control**

- 4.8.1 Authorising and maintaining management system documentation shall be the responsibility of designated competent personnel.
- 4.8.2 Controlled documentation shall not be amended without the authorisation of designated competent personnel or their appointed deputies.

## **4.9 Equipment inventory**

- 4.9.1 A list of major items of equipment and the location of each shall be maintained (a major item is defined as equipment that is critical to the validity of flow monitoring for example, the sensor and electronics).
- 4.9.2 Equipment records shall be kept for each major item. The records shall contain details of the equipment, its unique identifying code and any relevant calibration and maintenance requirements.

## **4.10 Maintenance**

- 4.10.1 Appropriate maintenance of the flow monitoring arrangements shall be carried out. Equipment shall be maintained/serviced at pre-defined intervals (for example, according to manufacturers' instructions or operating procedures) and whenever a significant deterioration is noticed. The frequency of scheduled maintenance activities, such as removal of fouling, shall be supported by documented observations. Up to date maintenance records shall be completed in a timely manner and kept where they can be accessed. These records shall include any problems encountered, for example due to adverse weather conditions.

## **4.11 Commissioning**

- 4.11.1 The Operator shall establish and maintain a procedure for commissioning replacement or modified flow monitoring systems (e.g. a new flowmeter or associated instrumentation) so as to ensure that they continue to conform to the requirements in Section 3.2.

## **4.12 Site changes**

- 4.12.1 The Operator shall establish and maintain a procedure to ensure that any changes that could impact flow monitoring (e.g. changes to manufacturing or effluent handling processes) are documented and the risk of them influencing the performance of the flow-monitoring equipment is assessed by a competent person. Records of such assessments shall be maintained. The competent person shall determine whether the MCERTS Inspection Certificate has been invalidated.
- 4.12.2 If the competent person's assessment indicates that the MCERTS Inspection Certificate has been invalidated then inspection by an MCERTS Inspector shall be carried out as soon as practicable.
- 4.12.3 If the competent person's assessment indicates that the MCERTS Inspection Certificate has not been invalidated, the Operator shall document their justification. The justification shall be available for examination by the MCERTS management system auditor at the next audit.

## **4.13 Verification**

- 4.13.1 The Operator shall undertake appropriate verification between MCERTS inspections over the entire certification period, to ensure that the flow monitoring equipment is operating satisfactorily.



4.13.2 Verification shall include at least one of the following methods:

- Calibration (i.e. in a calibration laboratory)
- Comparison with a secondary device, drop test or gravimetric calibration
- Reference plate checks (for open channel flowmeters)

4.13.3 Where the above methods are not possible, an alternative method is permitted. Any alternative method shall be agreed in writing with the MCERTS Inspector.

#### **4.14 Data treatment**

4.14.1 Where applicable, procedures for data treatment shall be included in the management system. The Operator's management system shall define the maximum acceptable data treatment/telemetry error.

4.14.2 The management system auditor is not required to carry out data treatment/telemetry verification measurements, but is required to ensure that:

- the appropriate checks are specified in the Operator's operating procedures
- the procedures are being implemented in a timely and appropriate manner
- the results are being recorded and analysed
- and that these are included in the overall assessment of the total uncertainty.

#### **4.15 Corrective actions**

4.15.1 In the event of departures from this MCERTS standard or from the operating procedures, corrective action shall be instigated and carried out by competent persons in a timely manner. The action taken shall be proportional to the significance of the departure and shall include prevention of recurrence. Records of such departures and the action taken shall be maintained.

#### **4.16 Internal audits**

4.16.1 Internal audits shall be performed according to a defined schedule to verify that operations continue to comply with the requirements of the management system and with the current version of this MCERTS standard. It is the responsibility of the designated competent person to plan and organise such audits. They shall be carried out by trained personnel who are operationally independent of the activity to be audited. Personnel shall not audit their own activities, except when it can be demonstrated that it will be effective.

4.16.2 The audit findings and any corrective actions arising from them shall be recorded. The Operator shall ensure that corrective action is implemented in a timely manner.

#### **4.17 Conformance assessment – management system**

4.17.1 The Certification Body conducting the management system audit shall be a UKAS accredited Certification Body or a Certification Body that is accredited by an Accreditation Body that is an International Accreditation Forum Multilateral Recognition Agreement signatory. Certification Bodies should have MCERTS: Self monitoring of flow included in their scope of accreditation. The management system auditor shall work on behalf of an accredited Certification Body.

- 4.17.2 The management system auditor shall assess the Operator's management system to ensure that the requirements of sections 4.4 to 4.16 have been met in relation to the flow monitoring arrangements.

## **5 Recertification**

- 5.1 An MCERTS Inspection Certificate is valid for five years. Sites shall undergo recertification within a period of five years from the previous MCERTS certification.
- 5.2 Sites can be re-inspected up to 12 months in advance of the MCERTS Inspection Certificate renewal date. If the site passes the re-inspection, then a new Certificate can be issued to run for five years from the expiry of the old Certificate. If the site fails the re-inspection, remedial work shall be carried out as soon as is practicable. A further inspection by the MCERTS Inspector is required to confirm that the site now meets the MCERTS requirements. The site shall meet the MCERTS requirements before the expiry of the current certificate which includes a re-assessment of the management system.
- 5.3 If there are any changes to the flow-monitoring arrangements that may affect the measurement uncertainty, then recertification shall be required as soon as is practicable.

## **6 Status of this document**

- 6.1 This MCERTS standard may be subject to review and amendment following publication. The latest version is available at [www.mcerts.net](http://www.mcerts.net)
- 6.2 Sira issues bulletins providing updates and additional guidance or instructions. These bulletins are available at: [www.siraenvironmental.com/mcerts](http://www.siraenvironmental.com/mcerts).
- 6.3 If you have any questions regarding the inspection process, please contact Sira at:

Sira Certification Service  
12 Acorn Industrial Park  
Crayford Road  
Crayford, Kent  
DA1 4AL

Phone: 01322 520500  
email: [mcerts@siracertification.com](mailto:mcerts@siracertification.com)

# Appendix 1

## Estimating the Uncertainty

### Part 1 Estimating the uncertainty of the total daily volume for effluent flow monitoring

- A1.1.1 MCERTS requires that, for effluent flow monitoring, the total daily volume shall be measured with a target uncertainty of  $\pm 8\%$  (or better) at a confidence level of 95%. This Appendix provides a generic method for determining the uncertainty of total daily volume from the meter uncertainty curve and a set of representative flow data for a typical day's discharge.
- A1.1.2 For wastewater treatment plants the typical day shall be representative of a "dry" day. For an industrial site, it shall represent a day when the plant is functioning within its normal operating capacity.
- A1.1.3 If flow data representing such conditions is not available from the permit holder (e.g. for a new site) the MCERTS inspector may apply a diurnal flow pattern considered to be appropriate for the size of the plant and nature of the process.

### Calculation of total daily volume uncertainty

- A1.1.4 A flow weighted average shall be used to calculate the uncertainty for total daily volume that takes account of the diurnal flow pattern at the site.
- A1.1.5 The flow/uncertainty curve that shall be used is the specific relationship between flow-rate and uncertainty for the metering system derived by the MCERTS inspector as a result of the site inspection.
- A1.1.6 The site flow data shall normally comprise a series of 96 fifteen minute values for a typical day's discharge; each value being the average flow-rate over a 15 minute period. In some cases the 15 minute values may represent the volume recorded in each period. In such cases it will be necessary to convert the volume to a flow-rate by dividing by the time.
- A1.1.7 The total daily volume shall be calculated by adding the 96 fifteen minute volume values over the day (flow-rate values will need to be multiplied by time to obtain the volume).
- A1.1.8 The uncertainty for each average flow-rate value shall be determined from the flow/uncertainty curve, interpolating between points where appropriate.
- A1.1.9 The contribution to the total uncertainty for each value shall be calculated by multiplying the uncertainty at that value by the volume for the period, divided by the total daily volume.
- A1.1.10 The uncertainty of the total daily volume shall be calculated by adding the

contributions over the day.

### Worked Example

A1.1.11 A flume is used to measure the discharge from a works. The flow/uncertainty curve derived from the site inspection is shown in Figure 1.1.

**Figure 1.1 – Flow/uncertainty curve**

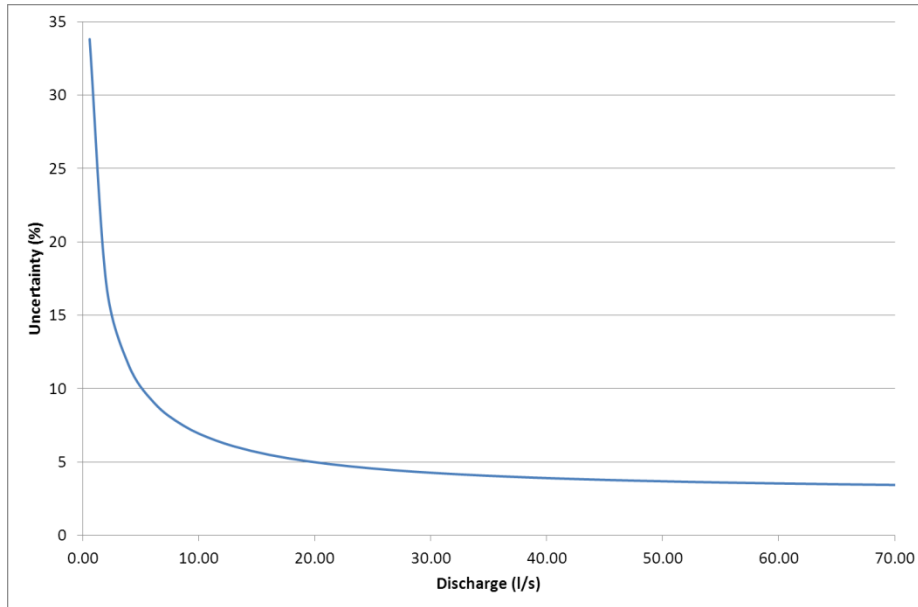

A1.1.12 The diurnal profile of flows from the works is shown by the solid line in Figure 1.2. The 15 minute average flow-rates are shown by the blocks.

**Figure 1.2 - Diurnal flow data**

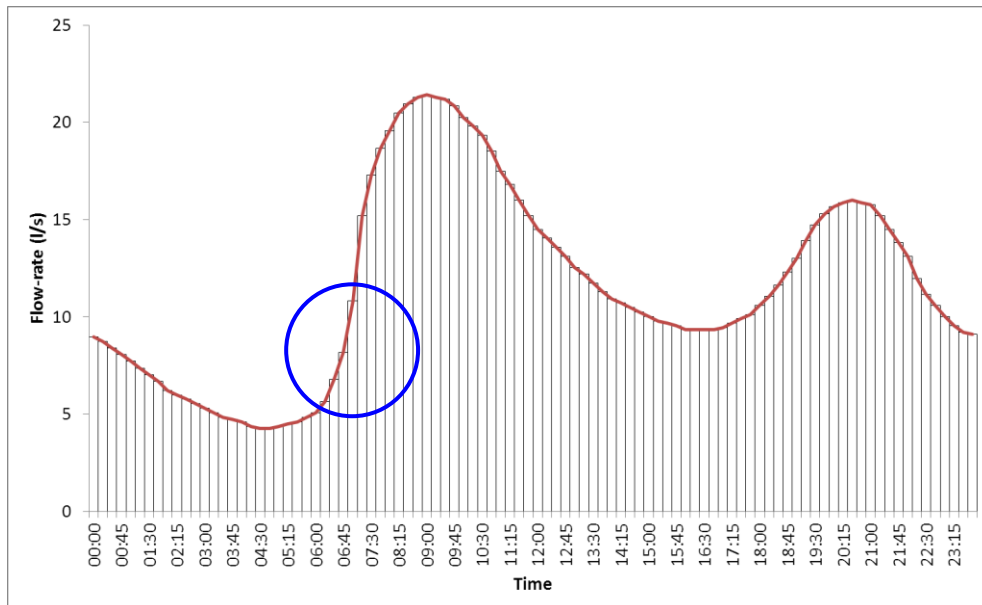

A1.1.13 Table 1.1 shows the calculation of uncertainty for the 4 values circled. The first two columns show the site data provided. The uncertainty (ui) at each flow-rate (qi)

was obtained from the curve in Figure 1.1. The volume in each 15 minute period was calculated by multiplying the flow-rate in l/s by 900 seconds and converting to cubic metres. These volumes were added over the day to give the total daily volume, in this case 1000 m<sup>3</sup> as shown at the foot of the table. The contribution of each reading to the total daily uncertainty was calculated by multiplying the uncertainty at that point (u<sub>i</sub>) by the 15 minute volume (v<sub>i</sub>) and dividing by the total daily volume. These contributions were added over the day to obtain the uncertainty in total daily volume, in this case 6.49% as shown at the foot of the table.

**Table 1.1 - Example calculations**

Site flow data provided		From flow/uncertainty curve	Calculated (q x 900 / 1000)	Calculated (u <sub>i</sub> x v <sub>i</sub> / Σv <sub>i</sub> )
Time	Average flow-rate (q <sub>i</sub> )	Uncertainty at q <sub>i</sub> (u <sub>i</sub> )	Volume in 15 minute period (v <sub>i</sub> )	Contribution to uncertainty
	l/s	%	m <sup>3</sup>	%
...	...	...	...	...
06:15	5.64	10.75	5.08	0.0546
06:30	6.79	8.64	6.11	0.0528
06:45	8.17	8.07	7.36	0.0593
07:00	10.82	6.85	9.74	0.0667
...	...	...	...	...
Totals			Σv <sub>i</sub> = 1000	U = 6.49%

## Part 2 Estimating the Uncertainty for instantaneous flow monitoring

- A1.2.1 Where the Environment Agency includes conditions in a permit requiring the Operator to measure instantaneous flow (e.g flow to full treatment), the flow shall be measured with a target uncertainty as specified in 3.2.2.
- A1.2.2 The uncertainty for instantaneous flow monitoring shall be determined from the flow/uncertainty curve, interpolating between points where appropriate.

### Part 3 Pumped or batch flows

A1.3.1 Care should be taken when using flow data from pumped flows or batch processes. Where flows have been averaged over a period that includes a pump or batch start / stop, the average flow-rate may not reflect the actual flow-rate and lead to an incorrect estimation of uncertainty. This is illustrated in Figures 3.1 and 3.2, and Table 3.1. In Table 3.1, the average flow-rates for each of the 15 minute periods shown in Figure 3.2 have been calculated and the corresponding meter uncertainty read from the flow/uncertainty curve in Figure 3.2. The contribution to uncertainty for each volume is calculated. The contributions are summed and divided by the total volume passed to determine the apparent uncertainty.

**Figure 3.1 Sample pumped flow data**

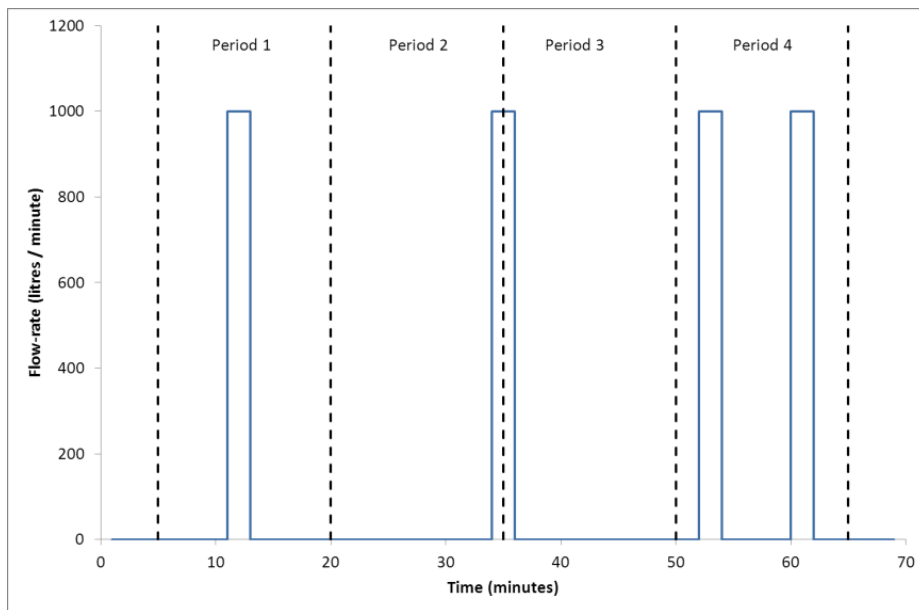

**Figure 3.2 Flow/uncertainty curve**

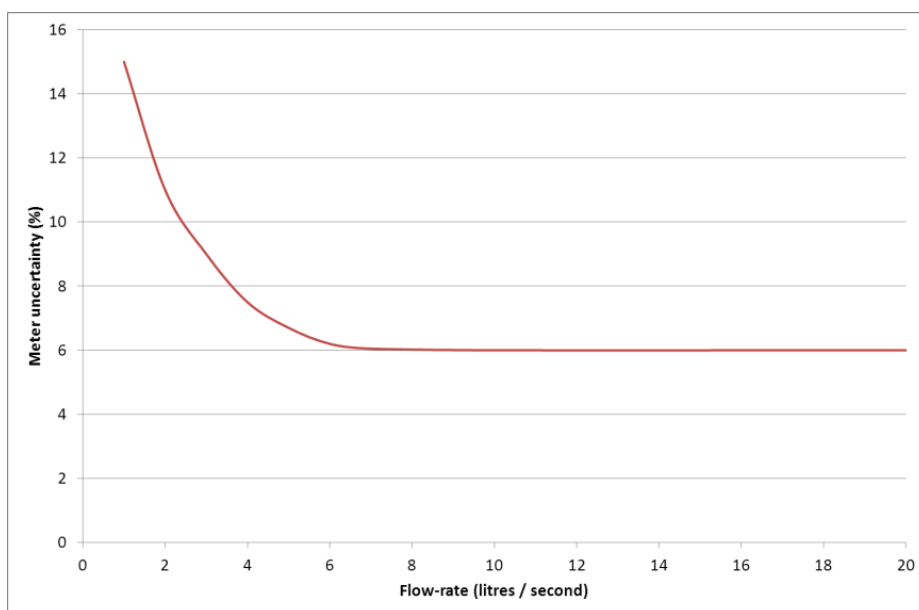

**Table 3.1 Meter uncertainty based on average flow-rate**

Period	Volume passed in period	Average flow-rate	Apparent meter uncertainty from Figure 3.2	Contribution to total volume uncertainty
	litres	l/s	%	litres
1	3,000	3.33	9.7	291
2	2,000	2.22	10.8	216
3	1,000	1.11	15.0	150
4	6,000	6.67	6.0	360
<b>Total</b>	<b>12,000</b>	<b>-</b>	<b>8.48%</b>	<b>1017</b>

However, this apparent uncertainty is a significant over-estimate as the actual flow-rate during each pumping cycle was 1000 litres/minute (16.67 litres/second) so the actual meter uncertainty should be 6%, before allowing for any other factors. As can be seen from this example, flow data based on average flow-rates may not enable the flow-rate during the pumping cycle to be immediately identified. The MCERTS Inspector should therefore establish an estimate of the flow-rate during the pumping cycle, for example by observation of the flow-rate shown by the meter, secondary measurement, rate of drop in a wet well or reservoir, or pump capacity data, to enable the uncertainty to be estimated.



- A1.3.2 The MCERTS Inspector should consider whether an additional component of uncertainty should be included for factors such as the ramp up and down periods where the pump or batch is starting and stopping. Measurement during this period may be affected by factors such as the response time of the flowmeter to such changes and the hydraulic conditions of the installation (for example, a closed pipe with an open discharge may take time to fill during which time the measurement will have a high uncertainty).

## Appendix 2

### Open channel flow-measurement system concessions

- A2.1 The concessions allowed under MCERTS will principally apply to existing hydraulic gauging structures for determining flow. It is expected that new hydraulic structures will be constructed to the best tolerances that current engineering practices allow and that these devices will remain sufficiently stable to maintain their dimensions for a minimum of five years.
- A2.2 The concessions documented here present “permissible” deviations from international standards (and recognise that the limits and tolerances prescribed are largely unachievable in the field). These concessions are based on the collective wisdom of expert knowledge currently available. They have no formal basis, nor are their effects on flowmeter uncertainty fully understood. As such, the concessions may be adapted in the future to reflect any improved knowledge.
- A2.3 Thin-plate weirs and long-throated critical depth flumes are covered in these concessions, as they are the most common types of open channel primary devices deployed for discharge measurement purposes.
- A2.4 The concessions must not be regarded as a prescriptive “tick sheet”. There may be situations where more than one characteristic is present in a hydraulic structure. It is up to the MCERTS Inspector to exercise professional judgement in considering whether the combined effect of these characteristics is likely to have an adverse effect on flow measurement. There may be occasions when the concessions are exceeded but it can be demonstrated that the installation can still achieve the target uncertainty.
- A2.5 All concession items must be logged and recorded, and some provision may be needed in the uncertainty budget (see paragraph 3.4 – Conformance assessment).
- A2.6 Ratios and limits defined in Standards will be followed where practicable; the MCERTS Inspector must exercise professional judgement to consider whether going beyond these limits has an adverse effect on flowmeter performance.
- A2.7 In the case of weirs, it is permissible to install and use drawdown penstocks to facilitate weir chamber cleaning provided they are not detrimental to weir performance when not operated.
- A2.8 Baffles are considered an acceptable solution to stabilise poor flow conditions, but must be fitted in such a way that they do not adversely affect the flow profile and conditions throughout the primary device’s operational range. Perforated plate flow straighteners will not generally be suitable for some applications (i.e. effluent flow monitoring) due to their fouling potential. In all cases measures must be taken to ensure that any risk of pollution is mitigated.

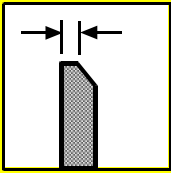
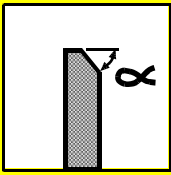
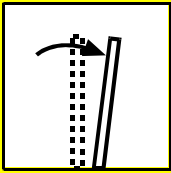
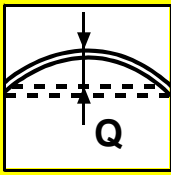
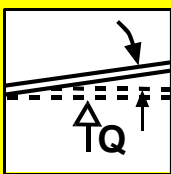

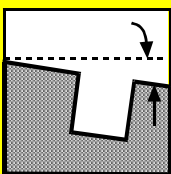
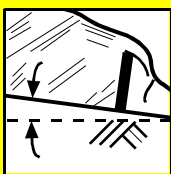
PRIMARY DEVICE				
1.1 Thin-plate Weirs – ISO 1438				
Parameter	Diagram	ISO 1438 Standards and Statements	Concession allowable under MCERTS	Clarification
Weir plate edge thickness		1-2mm		Also, there must be no evidence of weir edge erosion
Weir chamfer angle		As per standard		There must be free discharge throughout the range with full ventilation
Verticality of weir plate (degree of uprightness)		Must be vertical	No more than $\pm 5^\circ$ degrees from perpendicular	
Weir plate deflection (amount of bow)		Must be straight	No more than $\pm 2\%$ of maximum weir notch opening or full width for a fully contracted weir plate	
Deviation of weir plate normal to the flow (amount of skew)		Must be square	No more than $\pm 2\%$ of weir width (B)	
Centrality of weir plate (amount of off-centre)		Must be central	Non-central acceptable provided effects of sidewalls are minimal	The width of a weir plate fitted in a circular structure is taken as the chord length
Deviation of the weir plate in the horizontal plane (sideways level)		Must be true and level	No more than $\pm 2\%$ of weir width (B)	
Approach channel level (in the direction of flow)		Must be level	No more than $2^\circ$ slope from horizontal	If p is large in proportion to gauged head, then channel approach is deemed less critical. Account may need to be made for accurate referencing

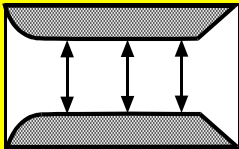
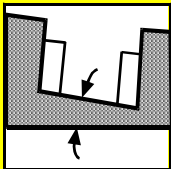
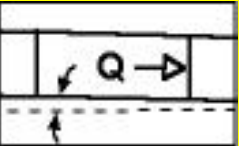
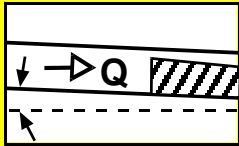
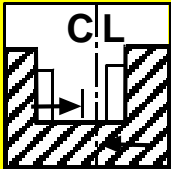
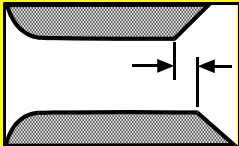
1.2 Long-throated, critical depth flumes – BS ISO 4359				
Parameter	Diagram	BS ISO 4359 Standards and Statements	Concession allowable under MCERTS	Clarification
Throat width variation (includes parallax error and non-uniform cross section)		No more than $\pm 0.2\%$ with an absolute maximum of 10mm Minimum $b = 100\text{mm}$	No more than $\pm 1.5\%$ up to and including throat width of 300mm  No more than $\pm 5\text{mm}$ for throat widths greater than 300mm  A minimum throat width of 50mm is acceptable provided that site conditions are appropriate. An additional 1% uncertainty will be added for structures where $b < 100\text{mm}$ .	Applies to critical area being measured where at least 12 transverse measurements are made (most importantly in the wetted area of the throat)
Throat transverse level variation		Average of $\pm 0.1\%$ slope from horizontal	No more than $\pm 1\%$	Over the measured length
Throat longitudinal level variation		Average slope of $\pm 0.1\%$ slope from horizontal	No more than $\pm 1\%$	
Approach level variation		$\pm 0.1\%$ of L slope from horizontal	No more than $\pm 1\%$ (for a distance $10 \times h_{\text{max}}$ upstream)	
Longitudinal level variation		$\pm 0.1\%$ of L slope from horizontal	No more than $\pm 1\%$	
Channel width variation			No more than $\pm 5\%$	
Centrality of flume (amount off-centre)		Must be central	No more than $\pm 5\%$ of approach channel width	
Staggered flume cheeks		$\pm 0.1\%$ of L	No more than $\pm 1\%$ of L	Cheeks can be staggered on both the upstream and/or downstream side

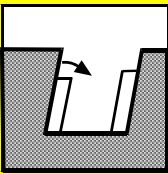
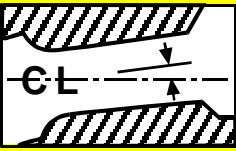
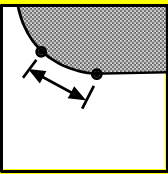
Vertical skew		Deviation from plane of other vertical or inclined surfaces $\pm 1\%$		
Horizontal skew		Deviation from plane of other vertical or inclined surfaces $\pm 1\%$		
Curvature of entrance transition		Arc governed by $R \geq 2(B-b)$ with an allowed deviation of $\pm 0.1\%$ of L	Deviation up to $\pm 5\%$	
Roughness value (Ks)		As per the standard		This can be subjective: suggest for all GRP, plastic and stainless steel devices use a Ks value of 0.6mm For all concrete devices use a Ks value of 1.5mm

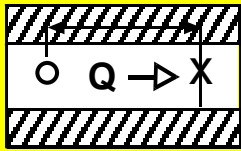
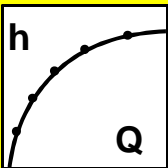
SECONDARY DEVICE				
Parameter	Diagram	Requirements in International Standards	Concession allowable under MCERTS	Clarification
Position of sensor		3-4 $h_{max}$ for flumes 2-4 $h_{max}$ for weirs <sup>1</sup>	Relaxation at the discretion of the MCERTS inspector	The point of measurement can be taken from the radial distance from the weir notch provided disturbances and other influences are avoided.
Method of determining flow		Use head to flow equations in standard	Can use Look-up-Tables provided relationship is originally determined using appropriate Standard	Errors using Look-up-Tables should be included in the uncertainty assessment

<sup>1</sup> Under the now superseded BS3680 Part 4A the head measurement was required to be 4-5 $h_{max}$  upstream of the weir. Existing sites compliant with the previous standard will maintain their certification but with a recommendation that when the installation is replaced, the measurement point be moved if it is practical to do so.

## Appendix 3

### Electromagnetic flowmeters for liquid flow in pipes

- A3.1 Electromagnetic flowmeters consist of two parts:
- the “sensor” detecting the flow of water, generally provided as a pipe section
  - the “converter” which provides calibrated measurement signals and a readout.
- A3.2 If the original factory calibration certificate is available, a copy shall be included in the MCERTS Inspection Report.
- A3.3 An on-site inspection by the MCERTS Inspector shall confirm that the flowmeter has been selected and sized correctly, that it is installed correctly and that the effect of any external influences has been assessed. The location of the meter as specified in Section 3.2.2 and its performance will also be assessed.

#### Meter performance

- A3.4 Meter performance shall be confirmed either by inspection with appropriate verification or by secondary testing.
- A3.5 Provision shall be made in the sensor installation for either verification or for secondary testing to be carried out. This may take the form of:
- provision of a suitable length of pipe adjacent to the meter to allow the temporary attachment of a clamp-on ultrasonic meter
  - access to the pipe end for basic volumetric tests (small flows), or insertion of a velocity/area meter or other temporary device
  - provision within the process of a suitable drop or fill tank which can be used from the flow assessment when required.
- A3.6 New or replacement electromagnetic flowmeter installations shall be provided with a means of access to allow inspections of the sensor to take place, including general condition, cable connections, earthing and bonding, confirmation of meter type, size, serial number and calibration factors. The design shall enable removal of the sensor if required.
- A3.7 New installations shall have sufficient exposed pipe available to install a clamp on flowmeter for verification purposes. The greater of 450 mm or 1.5 pipe diameters is recommended as a minimum.

#### Meter performance confirmed by inspection

- A3.8 The MCERTS Inspector shall inspect the flow measurement system to ensure that:
- the flowmeter has been selected and sized correctly for the application
  - in situations where there is more than one flowmeter on site, the converter is connected to the correct sensor
  - the liquid is not transporting entrained air
  - there is a match between the sensor and the converter
  - the converter is properly configured for the application, for example output scaling, meter bore and correct calibration factors read from the sensor head
  - the flow readings are stable

- the sensor is running full and is not subject to fouling and/or surface deposition
- there are no external influences, for example another electromagnetic flowmeter installed alongside the unit being assessed
- the earthing and bonding of the measurement system is appropriate to the type of meter and the type of pipe work installed.

A3.9 The meter uncertainties due to flow disturbances and other effects should be included in the overall site uncertainty calculation (see Table 1 Appendix 3 - sourced from authoritative works, for example WRc report CP259 and NEL documents).

A3.10 Verification shall be carried out at appropriate flow rates to confirm that the meter is performing satisfactorily and that there are no gross errors. The MCERTS Inspector shall record how verification was carried out. The verification shall demonstrate that the meter is operating under full pipe conditions and that the pipe diameter is not compromised by, for example, contamination leading to partial blockage. Significant errors could also be caused, for example, by the meter not being an appropriate size for the flow rate or being a different size to “as installed” information. For effluent flow monitoring, the agreement between the method of verification and the meter under test shall be within  $\pm 8\%$ .

A3.11 If the system fails any of the criteria detailed in A3.8, then an MCERTS Inspection Certificate cannot be issued unless the meter performance can be confirmed by secondary testing (see A3.13 – 3.19). NB: Section 2.5 (page 3) of this standard outlines the procedures that need to take place if a dispensation is required.

#### **Table of uncertainties**

A3.12 The MCERTS Inspector shall exercise his professional judgement in assessing the total uncertainty. Table 1 Appendix 3 Table of uncertainties (effects due to flow disturbances) and Table 2 Appendix 3 Table of uncertainties (other effects) give guidance and sets out the range of uncertainties for each component part. Each component of uncertainty shall be added in quadrature to determine the overall uncertainty for a particular installation.

**Table 1 Appendix 3 Table of uncertainties (effects due to flow disturbances)**

<b>Component</b>	<b>Uncertainty range</b>	<b>Guidance notes</b>
Single or double bend	1% - 2%	0-5 diameters upstream or 0-2 diameters downstream from the sensor; orientation of the meter to the bends may affect the uncertainty.
Valve	2% - 18%	0-5 diameters upstream or 0-2 diameters downstream from the sensor. The most significant effect is with a gate valve 50% open.
Conical contraction	0% - 1%	0-5 diameters upstream from the sensor.
Conical expansion	0% - 3.5%	0-5 diameters upstream from the sensor.
Incoming branch flow	0% - 1%	0-5 diameters upstream from the sensor.
Pumps	2% - 18%	0-20 diameters upstream from the sensor. Sensors should not be installed on the suction side of pumps.

Note: There is no direct correlation between the diameters specified in the guidance notes and the specified uncertainty range

**Table 2 Appendix 3 Table of uncertainties (other effects)**

<b>Component</b>	<b>Uncertainty range</b>	<b>Guidance notes</b>
Basic meter uncertainty	0% - 1%	A fixed allowance for the basic uncertainty in operation of the meter. A 1% allowance shall be made unless the factory calibration certificate shows otherwise.
Electronic verification uncertainty	1% - 3%	The electronic verification test will indicate several uncertainties for the meter, indicative of changes in the equipment since it was factory calibrated. These include the magnetism test (1% or 2%), mA output test and in some units a frequency test. These shall all be added in quadrature independently. If no electronic verification test is available, then 3% shall be allowed for this item.

Component	Uncertainty range	Guidance notes
Reverse flow uncertainty *	Calculated	<p>Calculated as:  <math>(\text{reverse flow total} \div \text{forward flow total}) \times 100</math>.            Reverse and forward flow totals to be read from the meter.</p> <p>Reverse flows can be a crucial component when calculating the overall performance of the flowmeter.</p> <p>If a site has a high reverse volume reading then this shall be taken into consideration when calculating the overall (forward) volume (e.g. the reverse flows are being counted again or “double counted”).</p> <p>The reverse volume needs to be subtracted from the registered overall forward volume.</p> <p>Some flowmeters have the facility to set readings to register “net volumes” (e.g. forward flows less reverse flows)</p> <p>It is always good practice when carrying out an MCERTS Inspection to re-set the forward &amp; reverse totaliser readings to zero. This then enables the forward &amp; reverse volumes to be assessed.</p>
Fouling (surface deposition) on the inside of the meter.	Assessed: method of assessment must be detailed.	Calculated by the MCERTS Inspector from the reduction in effective diameter of the meter. Refer to guidance notes for an example.
Air entrapment	Assessed: method of assessment must be detailed.	Entrapped air will displace water passing through the sensor causing over-reading of the flow.

\* For example, to overcome problems with leaky non-return valves. When a full pipe drains back to the wet well that volume is lost (not measured).

### Meter performance confirmed by secondary testing

A3.13 Under this method an alternative (temporary) means of flow measurement or a drop-test can be used to assess the flowmeter performance. This method is suitable for buried meters or other installations where an inspection cannot be carried out.

A3.14 Testing with an alternative means of flow measurement may be carried out by comparing the electromagnetic flowmeter with, for example, an insertion probe or clamp-on ultrasonic flowmeter. The measurement uncertainty of these reference methods may be considerably more than the manufacturer’s specification for an electromagnetic flowmeter. The MCERTS Inspector should be satisfied that the averaged results from the temporary means of flow measurement and the meter under test correlate adequately. The MCERTS Inspector will use the results in the overall site uncertainty calculation.

A3.15 For the alternative meter method, a volumetric test combined with instantaneous

readings shall be used. The volumetric check shall monitor the flow for a minimum of 10 minutes or 10 cubic metres, whichever is appropriate. The instantaneous readings shall be compared at different rates, typically at high, low and medium flows. At least 10 instantaneous readings shall be taken and the average used for the comparisons. Where it is not possible to take high, medium and low instantaneous flows it may be necessary to base the verification on a single test run. In such cases the number of readings taken shall still be a minimum of 10 but the volumetric test shall be extended to 20 minutes or 20 cubic metres whichever is appropriate.

- A3.16 Drop tests or fill tests may be carried out using any suitable tank or chamber. The actual volume is at the discretion of the MCERTS Inspector, but must be sufficient to allow valid comparisons to be made. The test shall run for a suitable period, at least long enough to allow flow conditions inside the pipe to stabilise. It is likely that the fill or empty period will be greater than one minute. Wherever possible the chamber or tank shall be vertically sided with a small cross section relative to its depth allowing accurate depth measurement and minimising volume errors. Care shall be taken to avoid errors due to empty or part empty pipes. If possible, the test should be repeated at high, medium and low flow rates. The volume recorded by the meter under test shall be compared to the volume discharged or displaced. The test shall be repeated at least three times, more if required.
- A3.17 Other “off line” techniques may also be possible if there is no ready access to the flow meter, for example:
- comparing flows at different flow meters within the site
  - installing a temporary flow meter at an appropriate location in the process.
- A3.18 The MCERTS Inspection report shall include a description of the equipment and the method/s used. Recorded data shall be included with the report to substantiate the results.
- A3.19 In circumstances when verification or secondary testing cannot be carried out then evidence will need to be provided to demonstrate that the meter is installed correctly and that significant fouling/deposition etc is not taking place.

### **Keeping the meter full**

- A3.20 The installation and design shall ensure that the pipe and sensor are running full of liquid at all times. Poor installation conditions may result in a partially filled pipe and sensor under certain conditions. Air entrapment will often result in rapidly fluctuating readings on the flow display.
- A3.21 Ideally the sensor should be orientated such that flow is always in an upwards direction. Any air contained within the water in the sensor will then be carried upwards through the sensor by the flow.

### **Fouling and surface deposition**

- A3.22 The location of the sensor shall be such that sediment cannot settle in times of low flow, for example in a vertical leg of pipe work (the bottom of an invert should be avoided). The installation shall allow access for appropriate, cleaning and maintenance to ensure that the meter’s performance is not affected. If the flowmeter is installed near the inlet or discharge point of the pipe, then jetting/ brushing may be



possible without separate access.

- A3.23 It is important to ensure that velocities through the meter are high enough to keep solids in suspension. Higher velocities will be required for untreated sewage than for final effluent. High velocities shall not be regarded as an alternative to regular cleaning.
- A3.24 The orientation of the sensor shall prevent the electrodes from becoming covered should silting occur on the bottom surface of the sensor pipe.
- A3.25 Table 3 Appendix 3 illustrates the errors in measurement for a 150mm electromagnetic flowmeter which result from a reduction of the meter cross-sectional area by surface deposition and so demonstrates the need for a rigorous cleaning regime.

**Table 3 Appendix 3 Errors due to deposition**

Surface Deposition (mm)	Resulting Error % Flow
1	+3
2	+5
3	+8
4	+10
5	+13

### **Cabling, earthing and bonding**

- A3.26 Electromagnetic flowmeters make use of magnetic and electric fields. Therefore, special potential equalisation procedures need to be followed for conductive pipes. Procedures vary depending on manufacturer, pipe material etc.

### **Flow disturbances due to other equipment**

- A3.27 Disturbances to the flow due to bends, valves, reducers or poor alignment will have a direct effect on the performance of the meter. Ideally, the sensor should be installed in a straight length of pipe of the same nominal diameter, with at least five straight pipe diameters upstream and two downstream.
- A3.28 Valves can have a significant affect on the performance of the flowmeter, particularly when partially closed. Experimental evidence indicates that, for example, a partially closed gate valve located directly upstream of the sensor can produce an error in flow measurement of up to 18%. Within 5 diameters upstream or 2 diameters downstream of the sensor, valves shall be assessed using Table 1 Appendix 3. Valves in this region which are intended to be permanently open shall be locked in this state.
- A3.29 Pumps can also have a very significant affect on the performance of the flowmeter. Ideally, pumps should not be installed within twenty pipe diameters upstream of the sensor. However, some pump types may permit installation within ten diameters. Sensors should not be installed on the suction side of a pump.

A3.30 If any of the above cannot be achieved due to physical constraints on site, then uncertainty allowances will be made for the flow disturbance sources. The MCERTS Inspector will use Table 1 Appendix 3 to calculate these uncertainties.

### **Other sources of uncertainty**

- A3.31 The MCERTS Inspector shall ensure that by-pass valves are secure (preferably locked off) to prevent un-planned use.
- A3.32 Reverse flows due to leaky or badly maintained non-return valves, flap-valves or by-pass valves will have a significant effect on flow measurement. Depending on the set-up, any backflow due, for example, to a leaking non-return valve may contribute towards a double-counting error.
- A3.33 Where possible, the MCERTS Inspector should establish that the flowmeter reads zero when no flow is passing through the flowmeter.
- A3.34 The flowmeter should be installed and operated in such a way that it is not affected by electromagnetic interference. Sources of such interference can include other electromagnetic flowmeters installed next to the unit under test (information from manufacturers indicates that there should be a space of at least 2 diameters between units), or mains cables run close by and parallel to the sensor cables of the unit under test. Other sources of interference may also exist.

### **Electronic verification**

- A3.35 Electromagnetic flowmeters are individually calibrated at the factory. Some manufacturers maintain accredited calibration facilities to maintain traceability of calibration for all flowmeters produced. During factory calibration parameters are stored in a non-volatile memory within the flowmeter/converter. Therefore each flowmeter has its own “fingerprint”.
- A3.36 Electronic in-situ verification tools perform a series of tests to evaluate the status of the complete flowmeter. These tests include checks on the converter, sensor, signal outputs, system insulation, cables and magnetic circuitry. A number of parameters are recorded and compared with the stored “fingerprint” values that were obtained when the flowmeter was calibrated by the manufacturer.
- A3.37 Electronic in-situ verification is considered to be a very useful tool for assessing the condition of installed electromagnetic flowmeters. However, electronic verification does not measure flow. It only indicates whether the meter characteristics, including fouling, are likely to have changed since the last time the meter was subject to verification. Assessing a electromagnetic flowmeter installation for MCERTS compliance by electronic verification alone is not acceptable.
- A3.38 The results of electronic verification are taken into account in Table 2 Appendix 3 and can be used as one element of an annual review procedure. Where a flowmeter is buried, inspection of as-installed drawings and/or photographs may enable the operator to demonstrate that the flowmeter has been installed correctly and that the measurement still represents the correct flow. Inspection of as-installed drawings and/or photographs is not necessary when the flowmeter can be verified by an alternative method, for example, a drop test.

## Appendix 4

### Installation and use of air firing ultrasonic level sensors for open channel flow measurement

- A4.1 This section of the Standard applies to flowmeters which comprise a single air firing ultrasonic level transducer linked to a flow computer. In such an instrument, the distance between the transducer face and the liquid surface is measured and then converted to head or stage (i.e. the depth of fluid above a set datum) upstream of a primary device, such as a weir or flume, and then to volumetric flow-rate.
- A4.2 The flowmeter shall incorporate means of compensating for changes in the speed of sound through air due to temperature variation.
- A4.3 Any new or replacement flowmeter shall hold product certification under the MCERTS standard: Performance Standards and Test Procedures for Continuous Water Monitoring Equipment - Part 3, over a certification range appropriate to the installation.
- A4.4 An on-site inspection by an MCERTS inspector shall confirm that the level sensor has been installed and set up correctly and that the effects of any external influences have been assessed.

#### Installation

- A4.5 The transducer shall be located at an appropriate distance upstream of the primary device, as defined by the relevant International Standard or manufacturer's instructions.
- A4.6 The fluid surface beneath the transducer shall be calm and free from foam, significant ripples, waves, vortices and swirl.

*Note: The following situations should be avoided where possible. If this is not possible, allowance shall be made for additional uncertainty in the measurement:*

- *Installations in enclosed spaces where a humid or gaseous atmosphere may build up between the fluid surface and the transducer which may affect the speed of sound*
  - *Installations where the liquid is at an elevated temperature leading to a significant temperature gradient between the transducer and the fluid surface. A separate temperature probe shall be used in such situations*
  - *Installations on batch discharges where the initial surge may be highly turbulent. Dampers or baffles upstream of the measurement point may be used to reduce such turbulence.*
- A4.7 The transducer shall be mounted directly onto a rigid frame or supporting bracket. The supporting structure shall be free from vibration.
- A4.8 Swinging or hinged mounting arms shall not be used unless they are necessary to facilitate maintenance, for example in deep chambers or wide channels where the transducer cannot be accessed from the side or from a walkway over the channel or chamber. The support will also need to be positively relocated into the same position repeatably after use.

- A4.9 Where a swinging or hinged arm is used, the MCERTS Inspector shall consider including an additional component of uncertainty in the uncertainty budget to account for the repeatability of repositioning.
- A4.10 On unmanned and remote locations, steps shall be taken to prevent tampering.
- A4.11 There shall be a clear path between the transducer face and the fluid surface.
- A4.12 The transducer shall be mounted perpendicular to and vertically above the fluid surface with the transducer face parallel to the fluid surface.
- A4.13 The instructions of the manufacturer regarding the tightness of the transducer mounting nut shall be observed. Over tightening of the nut can cause “ringing” and the instrument will either not measure or the measurement will be of poor quality.
- A4.14 The transducer face shall be located as close to the fluid surface at maximum depth/flow as practicably possible taking account of the instrument’s blanking distance. (The blanking distance being the minimum separation distance between the transducer face and the fluid surface required to obtain a measurement).

Note: *Ideally, the sensor face should be at a distance of: Maximum fluid depth + instrument blanking distance + safety distance above the chamber or channel floor, where the safety distance (typically 50 to 100mm) provides a safety margin to allow an alarm to be raised if the fluid depth exceeds its maximum in the case of flooding, channel blockage, backing-up etc.*

- A4.15 If the transducer is in an exposed location where it will be subject to direct solar radiation for a significant part of the day, particularly around mid-day when solar intensity is at its greatest, then the transducer shall be fitted with an effective sunshade.
- A4.16 Where a transducer is installed beneath a grille or grating it will be partially shaded by the grating. However, the extent of shading will depend on several factors including:
- mesh size
  - thickness of the grating
  - any shading provided by the chamber or channel walls
  - distance of the transducer beneath the grating and
  - orientation of the channel or chamber and mesh with respect to the passage of the sun.

In such cases, a sunshade shall be fitted unless it can be shown, to the satisfaction of an MCERTS inspector, that the transducer is effectively shaded.

- A4.17 A sunshade is not required where the transducer is installed beneath a solid, opaque cover.
- A4.18 If the instrument has a separate temperature sensor, it shall be located between the transducer face and the fluid surface, sufficiently offset from the ultrasonic path to avoid any interference with the measurement.

*Note: Ideally this would be midway between the transducer and the fluid surface at maximum flow.*

- A4.19 Where a separate temperature sensor is used, both the ultrasonic transducer and the temperature sensor shall be shaded from direct sunlight using the guidance outlined in A4.15, A4.16 and A4.17 above.

*Note: A submergence shield should be fitted if the transducer is installed below the walls of a channel or chamber that could flood and submerge the transducer.*

- A4.20 The transducer mounting shall be designed to facilitate the calibration or verification of the level measurement using a reference plate<sup>2</sup>, point gauge or gauge board.

- A4.21 The zero datum for the flow measurement shall be set appropriately for the primary device as defined in the relevant International Standard or manufacturer's instructions.

*Note: This may be different from the instrument datum used for the level measurement, in which case an offset will need to be programmed into the instrument to take account of any difference. It is not sufficient to rely on an empty chamber or channel as the floor may not be level.*

- A4.22 The primary structure (flow) zero datum, the instrument datum and any reference plate value shall all be set relative to a fixed point by survey levelling.

- A4.23 Where batch discharges are likely to be of short duration, a rapid response time shall be required from the instrument to ensure accurate measurement of the discharge.

### **Maintenance and verification**

- A4.24 The flowmeter shall be maintained and calibrated in accordance with the manufacturer's recommendations.

- A4.25 A means to verify the level measurement, such as a reference plate, point gauge or gauge board, shall be available and used.

- A4.26 Where a reference plate is used, the surface shall be level, clean and dry when a verification measurement is taken.

- A4.27 The transducer, temperature sensor (if present), mounting brackets and ultrasonic path shall be kept clear of cobwebs or other debris to avoid any possibility of interference with the measurement.

- A4.28 The transducer face shall be kept clean of any fouling or condensation.

- A4.29 Maintenance activities shall not affect the transducer operating position and alignment.

---

<sup>2</sup> A reference plate, also known as a swing plate, comprises a flat surface that can be repeatably set at a fixed known distance from the transducer face and above the primary device (flow) zero datum.