



**Technical Guidance Note
(Monitoring) M15**

Monitoring PM₁₀ and PM_{2.5}

**Environment Agency
July 2012
Version 2**

Foreword

This Technical Guidance Note (TGN) is one of a series providing guidance on monitoring to regulators, process operators and those with interests in stack emissions monitoring.

It provides guidance on stack emission monitoring and ambient monitoring of particulate matter with diameters less than 10µm. It focuses on the following:

- sources of PM₁₀ and PM_{2.5};
- health effects of PM₁₀ and PM_{2.5};
- general guidance on PM₁₀ and PM_{2.5} stack emission monitoring techniques;
- general guidance on monitoring PM₁₀, PM_{2.5} and PM₁ in ambient air.

This note does not discuss quantifying the mass concentration of particulate matter with a diameter of less than 1µm (PM₁) because a practical stack emission monitoring technique is not available.

The contribution of stack gases emissions to PM₁₀ and PM_{2.5} concentrations in ambient air can be classified as primary and secondary. Primary particulate matter exists as particulate matter within the stack gas and is emitted directly to air. Secondary particulate matter forms in ambient air due to atmospheric chemical reactions. The measurement techniques in this TGN do not measure the contribution of stack emissions to the formation of secondary particulate matter in ambient air.

Record of changes

Version	Date	Change
2	July 12	Section 4 – updated section on stack emissions monitoring methods to include a recently published European standard.
		Section 5 – updated section on limitations to size fractionation techniques.
		Annex 1 – added table showing size terms for particulates.
		Annex 2 – added information on particulate filter efficiency.

Feedback

Any comments or suggested improvements to this TGN should be e-mailed to Rupert Standing at rupert.standing@environment-agency.gov.uk.

Status of this guidance

This TGN may be subject to review and amendment following its publication. The latest version can be found on our web-site at: www.mcerts.net.

M15: Monitoring PM₁₀ and PM_{2.5}

Contents

1. Background.....	1
2. Sources of PM ₁₀ and PM _{2.5} in stack emissions	2
3. Health effects	3
4. Monitoring PM ₁₀ and PM _{2.5} in stack gas emissions	4
5. Limitations to the measurement of fine particulates	8
6. Measuring PM ₁₀ , PM _{2.5} and PM ₁ in ambient air.....	9
Annex 1: Particle sizes.....	10
Annex 2: Filter efficiency and fine particulates	11
References.....	12

1. Background

Particulate matter is released from various industrial processes via stack emissions to air. Abatement technologies are often used to filter the majority of particulate matter out of these emissions. Our aim when regulating industrial processes is to ensure that stack emissions do not add significantly to background levels of particulate matter in the environment.

Particulate matter can cause long term effects on people's health and reduce life expectancy, particularly in susceptible people like the young, the elderly and those with pre-existing heart and lung disease. Epidemiological studies carried out worldwide have identified a statistical link between the concentrations of PM₁₀ (see box 1.1 for definition of terms) in ambient air and detrimental effects on human health. These include increased incidences of hospital visits for heart and lung conditions and, in some situations, increased mortality. The most commonly reported health effect is an increase in asthma-related conditions, especially in children. To date, an actual cause-and-effect relationship has not been demonstrated between any specific component or characteristics of particulate matter and the reported health effects. Despite this, the presence of strong statistical association between particulate matter and health has resulted in new ambient legislation for PM₁₀ and PM_{2.5} in Canada, Europe and the USA.

Box 1.1 Definition of terms

Airborne particulate matter - this includes both organic and inorganic substances with diameters ranging from 0.001 to 100 µm.

Primary particulate matter - these are emitted directly to atmosphere. They tend not to change form once in the atmosphere. They can be from stack emissions but may also be from re-suspended soils and road dust.

Secondary particulate matter - these are formed in the atmosphere, usually as a result of chemical reactions, such as the oxidation of SO₂ and NO₂ in the presence of other pollutants.

Coarse particulate matter - particles between 2 to 100 µm in diameter.

Fine particulate matter - particles with a diameter of less than 2 µm. Fine particles below 1 µm travel deep into the alveoli region of the lung and may deposit on tissue or enter the bloodstream.

Ultra-fine particulate matter - particles with a diameter of less than 0.1 µm. In general finer particles are considered to have a greater toxicity per unit mass than coarser particles, as such ultra-fines are of significant interest in terms of health effects.

PM₁₀, PM_{2.5} - particles with a diameter of less than 10 and 2.5 µm. In stack emission measurements these are the particles which pass through a size-selective inlet with a 50% efficiency cut-off at 10 and 2.5 µm aerodynamic diameters respectively.

PM₁ - particles with a diameter of less than 1 µm.

More information about size fractionation terms are provided in Annex 1.

M15: Monitoring PM₁₀ and PM_{2.5}

PM₁₀ and PM_{2.5} monitoring may be necessary for a number of reasons:

- to improve data on particle behaviour in the atmosphere;
- to determine sources of emissions;
- to determine the efficiency of current pollution control equipment and to assess the requirement for further controls.

2. Sources of PM₁₀ and PM_{2.5} in stack emissions

Particulate matter present in ambient air is a combination of primary and secondary material. Primary particulate matter is released from stacks as particles, such as ash, dust or rapidly agglomerating aerosols. Secondary particulate matter forms from aerosols and gaseous species in the ambient air, downstream of the source. There are numerous formation processes for secondary particulate matter, which include chemical reactions, nucleation, condensation, coagulation and the evaporation of fog and cloud droplets in which gases have dissolved and reacted.

Sources of PM₁₀ and PM_{2.5} include:

- the combustion of coal, oil, gasoline/petrol, diesel, wood, biomass;
- the atmospheric transformation products of SO₂, NO_x, ammonia and organic compounds; including biogenic organic species such as terpenes;
- high temperature industrial processes, such as smelters and steel mills;
- natural sources including spores, viruses and dust from naturally dry areas;
- re-entrainment of particulate matter through agricultural activities and from road dust.

The composition of particulate matter is highly variable and may include substances such as sulphates, nitrates, hydrogen ions, ammonium, elemental carbon, silica, alumina, organic compounds, trace elements, trace metals, particle bound water and biogenic organic species. The mixture will vary with source type, location and weather conditions, such as temperature and wind direction.

Ambient air quality legislation in the UK and Europe applies to ambient concentrations of both primary and secondary particulate matter. However, source monitoring applies to primary particulate matter only, from sources, such as industrial activities and fuel combustion.

Figure 1 below shows the major sources of primary PM₁₀ in the UK and the trends in these emissions over the last three decades^{1,2}. The figure shows that emissions from industry and energy generation are a significant source of PM₁₀.

M15: Monitoring PM₁₀ and PM_{2.5}

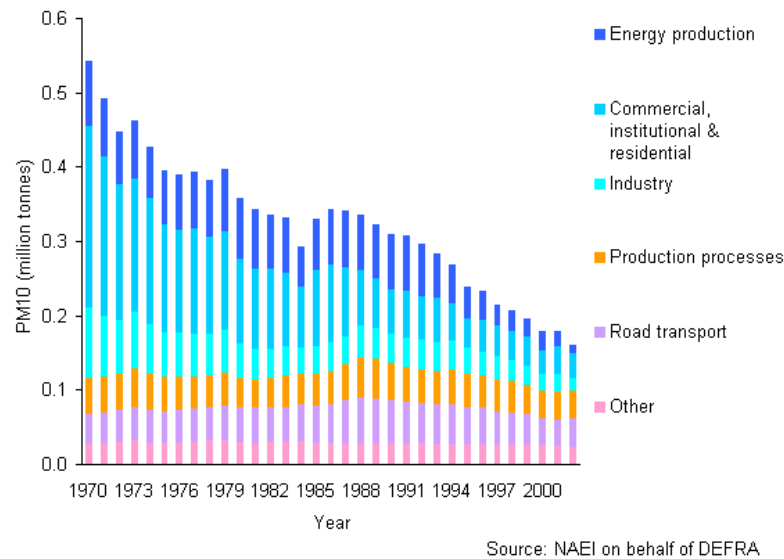

Figure 1 Emissions of PM₁₀ in the UK

3. Health effects

The main health concern regarding PM₁₀ and smaller fractions is the potential effect due to inhalation. Spherical particles below 10 µm in diameter may penetrate into the lungs, where they can cause damage^{3,4}

Since the late 1980s, numerous epidemiological studies have inferred a statistical link between the concentration of PM₁₀ in ambient air and health effects. These effects include:

- mortality;
- increased hospital admissions and emergency room treatment;
- increased incidence of pneumonia and exacerbation of chronic obstructive pulmonary disease;
- exacerbation of asthma attacks and broncho-dilator use;
- increased respiratory symptoms, such as coughs;
- decreased lung function.

By irritating the lining of the airways and lungs, PM₁₀ can cause nausea and irritation of the nose and throat. PM₁₀ can also cause the heart and lungs to have to work harder, placing stress on the cardiovascular system. Long-term damage can be caused to the cell linings in the lungs which can reduce the lungs' natural ability to clear foreign bodies, including bacteria, consequently weakening the lungs' defences against infection.

Although the statistical link is significant, there is little consensus on the actual mode of action of PM₁₀ to cause these health effects. Several modes of action have been suggested. These include the following:

- An inert size/mass effect. Smaller particles can travel deeper into the lungs than larger ones. They may become lodged in the lung tissue and cause inflammation and local immunological cell responses;

M15: Monitoring PM₁₀ and PM_{2.5}

- An acidity effect. Acidic species such as sulphates and nitrates may be carried deep into the lungs on the particulate matter. Again this causes inflammation, possibly leading to blockage of the airways. The acidity may also cause sensory inhibition of the lungs preventing the individual from taking a deep breath. Acidity can reduce the growth rate of the lungs in children, reducing their relative volume and increasing the risks of conditions such as asthma;
- A toxicity effect. The relatively large surface area of PM₁₀ can carry significant amounts of toxic species deep into the lungs. These include organic compounds, trace elements and biogenic species (such as viruses and fungi). Several studies have suggested an important link between transition metals such as zinc and inflammation of the lungs.

Along with other atmospheric pollutants, such as ozone, PM₁₀ can have an impact on visibility. In the USA this “regional haze” effect is targeted by specific legislation. As yet, this is not the case outside the USA.

4. Monitoring PM₁₀ and PM_{2.5} in stack gas emissions

4.1 EN ISO 23210

PM₁₀ and PM_{2.5} are measured in stack gas emissions using European standard: EN ISO 23210⁵.

Figure 2 is a schematic diagram of the size fractionation sampling systems that are used in the above standard. With the exception of the PM₁₀ and PM_{2.5} sizing device, this system is the same as the equipment used in the particulate sampling standard: EN13284-1⁶.

Figure 3 shows the size fraction device used in EN ISO 23210. It is known as a cascade impactor. The standard explains the theory behind the operation of this device. In summary, impactors consist of a series of nozzles and impaction plates, which separate particles according to their aerodynamic diameter. The sample stack gas is drawn through a nozzle onto a plate at a previously determined volumetric flow rate. The plate causes the gas to be deflected at 90° along the surface of the plate. Larger particles will be impacted onto the surface of the plate, due to their mass inertia. Finer particles remain suspended in the stack gas and continue to the next stage of the impactor. Each impactor plate has a cut-off point, where 50% of the particles of a certain aerodynamic diameter will be deposited on the plate and 50% passes to the next stage.

In the two-stage impactor, the particles are divided into the following three fractions based on their aerodynamic diameters:

- greater than 10µm (first impactor)
- between 10µm and 2.5µm (second impactor)
- smaller than 2.5µm (backup filter).

M15: Monitoring PM₁₀ and PM_{2.5}

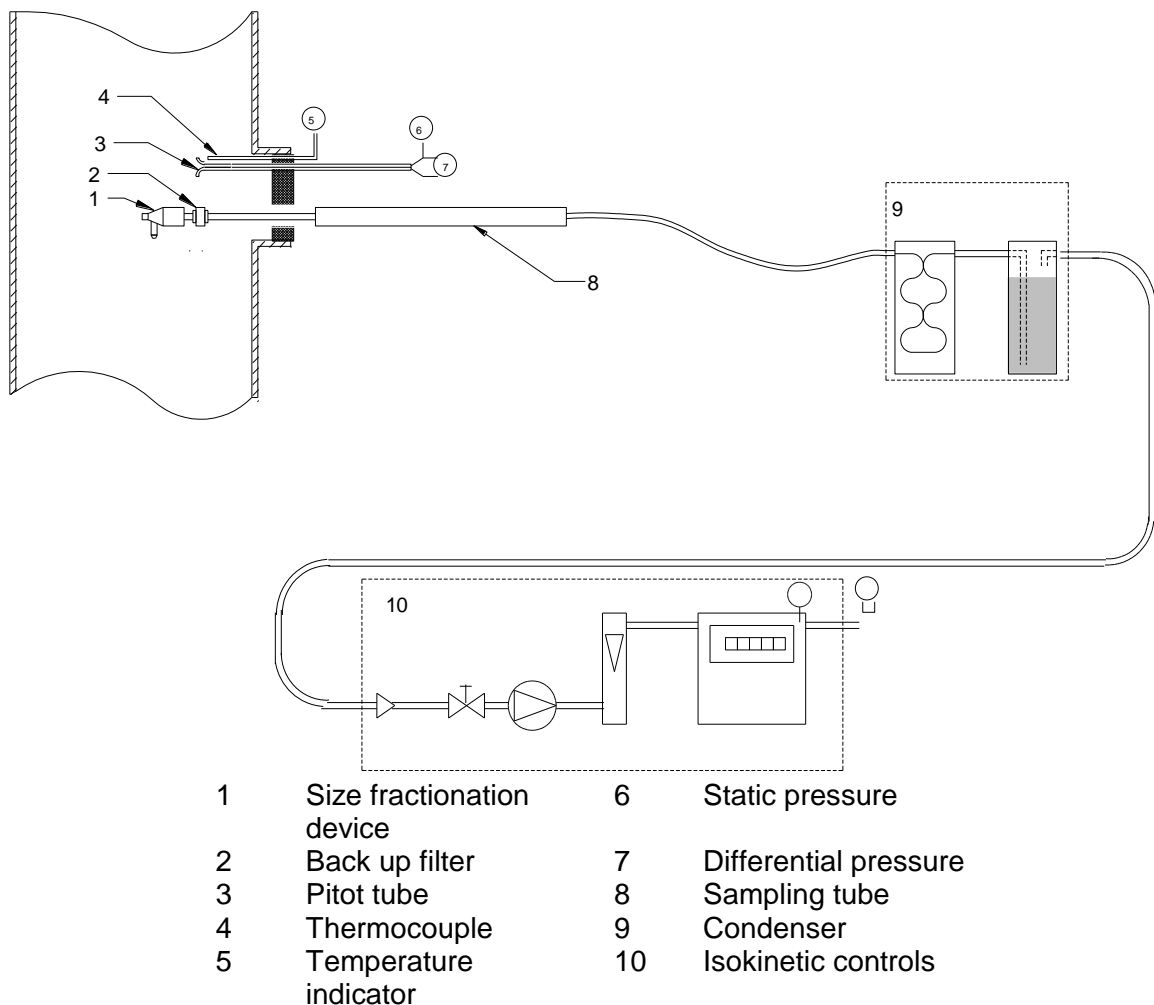

Figure 2 In-stack sampling system

4.2 Orientation of the cascade impactor

The cascade impactor should be positioned in the stack, so that it points in the same direction as the flow, a vertical orientation in a vertical stack. However, quite often, due to restricted access into stacks, it is necessary to install the impactor into the stack at 90° to the flow direction giving a horizontal orientation in a vertical stack. Under these circumstances a goose neck nozzle is used to ensure the nozzle points into the direction of flow.

If access to the stack prevents the cascade impactor from being inserted into the stack, it is possible to use an out of stack configuration where the cascade impactor remains out of the stack and is connected to a probe, which is inserted into the stack. This is technically challenging and should only be attempted as a last resort. This configuration is difficult to set up because it requires the use of very accurate external thermal control to ensure the impactor meets the exact particulate cut-off diameter.

Figure 3 Two stage Cascade impactor

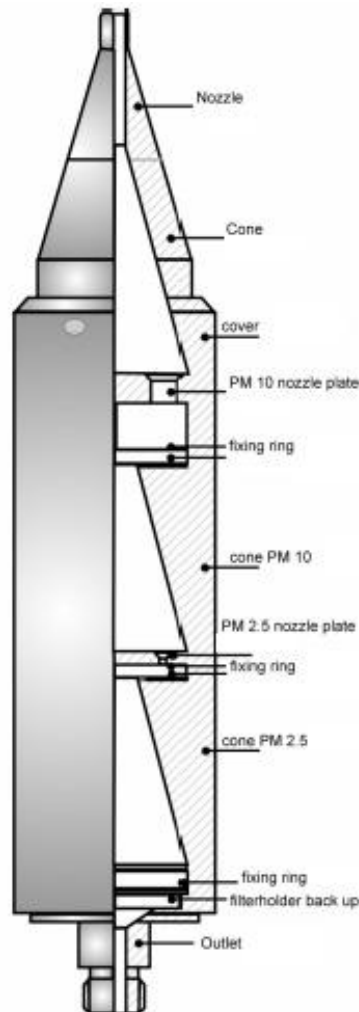

4.3 Applicability and limitations of EN ISO 23210

EN ISO 23210 is applicable to stack gas emissions with particulate mass concentrations below 50 mg/m³ (the standard states that it was primarily developed for stack gas concentrations below 40 mg/m³ but within the text it states that it is suitable for gases with particulate concentrations between 1 – 50 mg/m³). The standard does not specify whether this is “as measured” in the stack or after correction to standard conditions. It is assumed that it is “as measured” because it is the effect of particle overloading of the impactors that is of concern.

For stack gas emissions with particulate concentrations above 50 mg/m³ a cyclone may be used instead of a cascade impactor. Information on the appropriate cyclone method is provided in TGN M2⁸.

M15: Monitoring PM₁₀ and PM_{2.5}

EN ISO 23210 describes the typical stack gas characteristics where the method can be applied effectively. It specifies limitations on stack gas temperature (1 – 250°C), pressure (85 – 110KPa) and humidity (0 – 110g/m³). It is also a requirement that the stack gas dew point is below the stack gas temperature.

The standard cannot be used to measure stack gases that are saturated with water vapour. It is also not applicable to stack gases where the majority of particulates are greater than PM₁₀.

The standard states that impactors always exhibit losses of mainly coarse particles, diffusively on the walls and the nozzle plates of the cascade impactor. Therefore, adding all the fractions to obtain total particulate matter cannot be done. These losses prevent the standard being used to provide a result for total particulate matter. If the PM_{2.5} and PM₁₀ fraction in the total particulate is to be determined, additional total particulate measurements, using EN 13284-1 are required.

4.4 Preparation and preliminary measurements

It is important that the expected particulate concentration and flow characteristics of the stack gas are known, so that an appropriate sample duration and location can be selected. When selecting a sample location, it is important to be aware that the cascade impactor requires a set flow rate, which means adjustments to maintain isokinetic conditions during the test are not possible.

The fixed sample point should be located at a representative point within the stack. The sample nozzle selected should be as close to isokinetic conditions as possible. The representative fixed point is selected by using the principles outlined in the standard, which are based on the homogeneity survey described in EN 15259⁷. The standard recognises that this is very difficult to carry out for particulate measurements, so suggests that a surrogate can be used, such as temperature or oxygen. Although not referred to directly in the standard, velocity would also be a suitable surrogate.

In order to select a suitable sample duration for a test, it is necessary to know the particulate concentration and the grain size distribution. This is needed because it is important to ensure that:

- a weighable mass of particulates are collected
- the collection plates and back up filters are not overloaded.

The particulate concentration information is usually readily available from previous monitoring or from data from continuous emissions monitoring systems. However, the grain size distribution is not readily available, which means that this information can only be assessed by taking preliminary measurements and examining the particle size distribution.

4.5 Post sample checks

Unlike other sampling methods, it is not necessary to carry out a sample train leak check at the end of the sampling run. This quality assurance check is not included because the leak check procedure is likely to result in the distribution of the collected particulate matter in the sample train being disturbed.

At the end of each test it is necessary to check for visible particulate deposits on the walls of the first nozzle plate in the internal part of the impactor. Such visible deposits indicate that there are a significant number of coarse particles. If these are present, it is necessary to examine the backup filter with a scanning electron microscope. This examination is carried out to show if coarse particles have bounced onto the backup filter. If they have the measurement method is not suitable for the process under investigation and the measurement results are invalid. If no coarse particles are detected on the backup filter, the measurement is valid but the particulate deposits upstream of the first nozzle plate are not taken into account for the determination of the PM_{2.5} and PM₁₀ size fractions, since these deposits consist mainly of coarse particles.

5. Limitations to the measurement of fine particulates

PM₁₀ and PM_{2.5} in ambient air consists of both primary and secondary particulate matter. The primary material comes from specific sources, such as stack emissions, whereas the secondary matter is formed by reactions in ambient air. Stack gases may contribute to these reactions. This means that the contribution of stack gases to the concentration of particulate matter in ambient air is not determined by simply measuring PM₁₀ and PM_{2.5} in the stack.

Advances have been made to replicate the formation of secondary particulate matter by mixing stack gas with ambient air and controlling its residence time in the sampling system. An international standard is being developed to enable the standardization of this measurement. Until the publication of a suitable standard, this measurement is generally not available.

One practical consideration that may cause problems is collection of sufficient sample to meet the limit of detection of the method. For stacks that have low particulate emissions, such as below 3 mg/m³, it is generally not worthwhile carrying out PM₁₀ and PM_{2.5} measurements because of the length of time it would take to obtain measurable size fractions. Under these circumstances a worst case scenario approach could be adopted, where the total particulate matter is assumed to be a measure of PM₁₀. Further size fractionation at these low concentrations would not be feasible.

Finally, although there has been increased interest in the health effect of PM₁, it is currently not possible to obtain sampling equipment that enables it to be measured as a separate size fraction within in stack gases. However, although it cannot be measured separately, the submicron particles (particles with a diameter of less than 1µm) are measured as part of the <PM_{2.5} fraction (see Annex 2).

6. Measuring PM₁₀, PM_{2.5} and PM₁ in ambient air

Unlike the stack emissions monitoring techniques described in Section 4, measuring particulate matter in ambient air is a measure of both primary and secondary particulate matter. Besides this fundamental difference, monitoring ambient air for particulate matter size fractionation differs from stack emission measurement in the following ways:

- there are a range of different techniques available (see TGN M8)⁹
- near real time continuous data can be obtained;
- some techniques can measure PM₁.

Most ambient air particulate matter measuring systems can be modified to collect particles at specific size fractions. The most common approach is to use size selective inlets. Some inlets are simply sampling heads with a geometry that favours a certain particle size range or with a particular upper cut-off point. Other selective inlet systems separate the particles after the sample has been entrained in the sampling system. Examples of these are cascade impactors, single stage PM₁₀ heads and cyclone heads for separating PM_{2.5} from PM₁₀.

Cascade impactors are useful as they provide the full particle size distribution by mass. The impactors work by the same principle as the ones used for stack emission monitoring. Most ambient monitoring cascade impactors consist of several impaction plates, which can give up to ten cut size ranges, including PM₁₀, PM_{2.5} and PM₁.

The most straightforward of the ambient monitoring techniques available is to draw air through filter papers using pumps followed by gravimetry (weighing before and after sampling). In order to measure different size fractions a size specific sampling head or cascade impactor device is used. This technique is considered to be the reference method for sampling particulate matter in ambient air. However, it provides an average result, such as over a 24-hour period, which means it is of limited use for trend analysis purposes. Also, as the filters have to be weighed after sampling there is a delay in obtaining results, which limits the use of this technique for rapid pollution warning information.

Another technique that provides an almost real time continuous measure of PM₁₀, PM_{2.5} and PM₁ is tapered element oscillating microbalance (TEOM). The measurement of different size fractions is selected by using a sampling head that selects material of the relevant size fraction. These devices are often used in long-term air quality monitoring networks. However, there is some concern that the nature of the technique, which involves heating the ambient air to temperatures of 50°C to prevent condensation, may result in losses of volatile particulate matter. The TEOM is used in the UK's air quality monitoring network, with a correction factor applied to results to help compensate for the loss of volatile particulate matter.

PM₁₀ and PM_{2.5} can also be measured in ambient air using beta gauge monitors fitted with selective sampling inlet systems for measuring PM₁₀ and PM_{2.5}.

A further technique uses light scattering systems as optical particle counters to provide information on the number of particles present in different size ranges. They work on the principle that there is a relationship between the scattering of light that reaches a particle and the particle size. Size selective sampling heads are used to measure PM₁₀ and PM_{2.5}.

Annex 1: Particle sizes

Table A1: Particle sizes

Size fraction	PM	Size (m)	Size (µm)*	Size (nm)
Coarse	>PM ₁₀	>1 x 10 ⁻⁵	>10	>10000
	<PM ₁₀	<1 x 10 ⁻⁵	<10	<10000
	>PM _{2.5}	>2.5 x 10 ⁻⁶	>2.5	>2500
Fine	<PM _{2.5}	<2.5 x 10 ⁻⁶	<2.5	<2500
	<PM ₁	<1 x 10 ⁻⁶	<1	<1000
Ultrafine	<PM _{0.1}	<1 x 10 ⁻⁷	<0.1	<100
			0.08**	<80
			0.03***	<30
Nanoparticles	<PM _{0.001}	<1 x 10 ⁻⁹	0.001	1

*1µm = 1m x 10⁻⁶

** 0.08 submicron fume, for example vaporized metals from coal

***0.03µm (30nm) minimum size range detected by research projects carried out in Denmark and France^{10,11}

Annex 2: Filter efficiency and fine particulates

Fibrous filters are used in stack gas abatement plants to remove particulate matter.

Fibrous filters are also used for collecting particulates in the method used for measuring particulates in stack gas emissions.

In stack gas emissions monitoring, particulates are collected by the following mechanisms:

- **Gravitation**
It is possible that larger particles settle out of the sample gas stream by gravitation before reaching the filter. These will be recovered during a rinse of the sampling equipment. They will be included in the overall sample result.
- **Impaction**
Particles impact directly into the fibres of the filter.
- **Interception**
Particles are trapped between the fibres of the filter.
- **Diffusion**
This is the main mechanism for collecting particles with a diameter of less than 0.3µm.

Further information is available from “Fundamentals of aerosol science”, D.T. Shaw¹².

The least efficient collection occurs for particles with a diameter of 0.3µm. This is due to the combination of different mechanisms being least effective for this size of particle.

Due to this, the European standard reference method for measuring particulates (EN 13284-1) states that the filters used in this method must have an efficiency of 99.5% for particles of 0.3µm diameter.

It is a common misconception that particle sizes below 0.3µm are collected less efficiently or even missed completely by this method. In fact, particles with diameters of <0.3µm will be collected at a greater efficiency than the 0.3µm particles, which means that the collection efficiency, as the particle size decreases, approaches 100%.

This is supported by research work on the characterisation of ultrafine particles from a waste incinerator¹³. The presence of a fabric filter abatement system resulted in negligible particulate concentration levels at the stack. The concentration of particles measured at the stack was about 10 times less than the concentration of particles measured in the surrounding rural location. The research also showed that the ultrafine particle concentration at the stack was lower than the typical background concentration. The results suggest that more than 99.99% of ultrafine particles were removed by the fabric filter.

References

1. NAEI (2004) PM₁₀ (particulate matter <10 µm). UK National Atmospheric Emissions. 1 pp Inventory web site: <http://naei.org.uk/pollutantdetail.php> (Apr 2004)
2. Committee on the Medical Effects of Air Pollutants, UK (1998) Quantification of the effects of air pollution on health in the United Kingdom. London, UK, HMSO, Department of Health, 78 pp (1998)
3. Dockery D, Pope A (1996) Epidemiology of acute health effects: summary of time-series studies. In: Particulates in our air: concentrations and health effects. Wilson R, Spengler J D (eds), Cambridge, MA, USA, Harvard University Press, pp 123-147 (1996)
4. Schwartz J, Dockery D W, Neas L M (1996) Is daily mortality associated specifically with fine particles? *Journal of the Air and Waste Management Association*; 46 (10); 927-939 (Oct 1996)
5. BS EN ISO 232210: Stationary source emissions - Determination of PM10 and PM2.5 mass concentration in flue gas – measurement in low concentration by use of impactors.
6. EN 13284-1 Stationary source emissions - Determination of low range mass concentration of dust - Part 1: Manual gravimetric method BS DN 13284-1:2002
7. BS EN 15259:2007 Requirements for measurement sections and sites and for the measurement objective, plan and report
8. Technical Guidance Note M2, Monitoring of stack emissions to air, Environment Agency
9. Technical Guidance Note M8: *Monitoring methods for ambient air*, Environment Agency.
10. Measurement and characterization of fine and ultrafine particles in emissions from CHP Plants in Denmark (2009) Karsten Fuglsang, Jacob B. Markussen, Thue G. Frederiksen, Karina B. Hummer FORCE Technology
11. Determination of size distribution and chemical composition of fine particulate emissions from cement kilns (2009) D.Laffaire, I.Fraboulet, S.Sobanska, K.Tack, E.Fiani, O.Le Bihan, ATILH, INERIS, Laboratoire de Spectrochimie Infrarouge et Raman, ADEME
12. D.T. Shaw (1978) Fundamentals of aerosol science. Wiley-Interscience, New York.
13. Buonanno, G., Stabile, L., Avino, P., Belluso, E. (2011) Chemical, dimensional and morphological ultrafine particle characterization from a waste-to-energy plant. *Waste Management*. 31 2253–2262