

Certificate

Pursuant to section 12 of the Weights and Measures Act 1985

Certification No 2843 Revision 4

Valid Until 06 May 2018

In accordance with the provisions of section 12 of the Weights and Measures Act 1985, the Secretary of State for Business, Innovation & Skills hereby certifies as suitable for use for trade a pattern of a liquid measuring instrument, as described in the descriptive annex to this Certificate, and having the following characteristics:-

A liquid measuring instrument for dispensing beer, stout or cider in nominal quantities of ½ pint and 1 pint. The unit and system are designated 'ExacTap' and is intended for use at stadia or similar large venues where high volumes are required over short periods. Operation is electronically controlled with interlocks to ensure correct measure.

Note: This certificate relates to the suitability of the equipment for use for trade only in respect of its metrological characteristics. It does not constitute or imply any guarantee as to the safety of the equipment in use for trade or otherwise.

Under the provisions of section 12(5) of the said Act, the certificate is subject to the conditions as given in the descriptive annex.

This revision replaces previous versions of the certificate.

*Submitted by: Niagara Dispensing Technologies
170 Northpointe Parkway,
Suite 500
Amherst, NY 14228
USA*



Signatory: P R Dixon
For Chief Executive
National Weights & Measures Laboratory
(part of the National Measurement Office)
Department for Business, Innovation & Skills
Stanton Avenue
Teddington
Middlesex TW11 0JZ
United Kingdom

CONTENTS

CERTIFICATION NO 2843

- 1 INTRODUCTION**
- 2 CONSTRUCTION**
 - 2.1 Mechanical**
 - 2.2 Electrical / Electronics**
 - 2.3 Securing (sealing)**
- 3 OPERATION**
 - 3.1 Controls and Features**
 - 3.2 Operation Sequence**
 - 3.3 Interlocks and safeguards**
 - 3.4 Software security and version control**
- 4 LEGENDS**
- 5 AUTHORISED ALTERNATIVES**
 - 5.1 Addition of a 2 pint dispense volume**
 - 5.2 Dual Dispense head**
 - 5.3 Mobile unit**
 - 5.4 Alternative mobile configuration**
 - 5.5 Alternative manufacturer**
 - 5.6 Interactive FoB**
 - 5.7 Alternative sealing arrangements**
- 6 RECOMMENDED TESTS**
- 7 CONDITIONS**
- 8 ILLUSTRATIONS**
- 9 CERTIFICATE HISTORY**

Descriptive Annex

1 INTRODUCTION

This type of measuring instrument is for dispensing measured nominal quantities of ½ pint and 1 pint of Beer, Stout or Cider by specifying the required volume on the touch pad control panel at the top of the head, and pulling the dispense spout forward, activating the required pour volume. The manufacturers designation for the dispense unit is “ExacTap” (Figure 2a). The system is designed to dispense, at a series of controlled speeds, approximately 3 seconds per 1 pint on beer and cider and 5 seconds on smooth and stout. An example schematic view of the system is shown in Figure 1a. Satisfactory dispensing requires that the temperature of the liquid be within the range 0 to 6 degrees Celsius (typically 3 degrees) during delivery.

2 CONSTRUCTION

2.1 Mechanical

The measuring instrument comprises a beer pump, an electrically integrated Froth on Beer (FOB) detector, a turbine flow meter, a beer supply pressure measure, a flow regulator valve, a keg pressure valve, a dispense head which comprises of a dispense valve, and an integrated control unit.

Gas is normally used to push the product from source through to each tap. Where this is not efficient in achieving the desired speeds a pump may be used. The instrument may be fitted with a cooling unit.

The integrated FOB detector (Figure 7), can be mounted on either the cellar-board, which also contains the manifold, or (on a mobile setup) directly onto the side of the cooler. The integrated FOB detector can be sourced from any supplier. The only requirement is that the integrated FOB detector should hold a minimum of 1.5 pints and inhibit dispensing when either the keg empties or there is excess gas in the system.

Note: The integrated FOB detector may be overridden for cleaning purposes only.

2.2 Electrical / Electronics

2.2.1 The head is operated by 12 volt DC, which is supplied by a separate mains (240 volt AC) switching power supply.

2.2.2 The control unit, which comprises of the main CPU and control circuit, has inputs for flow meter counts and beer air pressure and an output for solenoid control. The control unit is housed in the top of the dispenser. The front of the control unit (Figure 3) has a membrane keypad and a display panel, which may show information including the desired pour volume.

2.2.3 The device utilises an integral turbine style flow meter manufactured by GEMS, model number 173935, for precise volumetric measurement.

2.3 Securing (sealing)

2.3.1 Three variations of cover can be used to seal the head (Figures 4a, b, c, d). All covers are secured with sealing wire and a soft metal seal to prevent tampering.

- Figure 4a – NDT 3 piece plastic cover. The 2-piece shroud is riveted on one side, and screwed and wired on the other. The shroud covering the top of the head is also screwed and wired into position under the membrane keypad. (Figure 5)

- Figure 4b – DDg 2 piece fabricated cover. The 2 piece shroud is screwed at the top and wire sealed at the base.
- Figure 4c – NDT Oprema cover. The stainless steel shroud, covering the operators side of the unit is wire sealed at the base. The seal is subsequently covered with a slide in place moulded plastic component.
- Figure 4d – DDg 2 piece fabricated cover. The 2 piece shroud is riveted on the side and wire sealed at the top.

2.3.2 Where indicated above sealing wire is passed through diagonally opposed holes and secured with a soft metal/plastic seal (Figure 6).

3 OPERATION

3.1 Controls and Features

3.1.1 A dispense cycle is activated by specifying the required volume on the touch pad control panel. The chosen volume will appear on the LCD display. The required dispense is then activated by pulling the dispense spout forward, activating the required pour volume.

3.1.2 The software version is displayed on the LCD screen during power up initialisation along with the product type to be dispensed. This also highlights if a creamer plate has been fitted (smooth and stout heads only). The serial number and identification sticker are mounted on the underside of the head, behind the spout.

3.2 Operation Sequence

A dispense cycle is activated by specifying the required volume on the touch pad control panel. The chosen volume will appear on the LCD display. The required dispense is then activated by pulling the dispense spout forward, activating the required pour volume. The nozzle will open and liquid will be dispensed. When the required volume has been detected by the control system, the nozzle is closed.

Ensure that the spout is as close to the bottom of the appropriate fill receptacle as possible. Once activated, ensure that the spout remains submerged below the liquid surface level until the pour volume cycle has been completed.

3.3 Interlocks and safeguards

3.3.1 The keg top pressure is set at the required equilibrium pressure for the specific liquid and gas.

3.3.2 Dependent on the length, diameter and elevation of line (pipe) to the dispense head, the pump pressure is set to deliver at the required dispense flow rate.

3.3.3 If the flow rate is too low, the control unit will terminate a pour to prevent an out of specification pour.

3.3.4 The beer supply/delivery pressure to the dispenser is monitored by either:

- Measuring the gas top pressure supplied to the keg for systems not utilising a pump.
- The beer discharge pressure from the pump, for systems utilising a pump.

If the beer delivery pressure falls below a specified minimum level subsequent pours are inhibited, and the dispenser reports a low pressure fault on the LCD display. The optimum delivery pressure is 2.5 to 3 bar.

3.3.5 The system cannot be re-initiated until the dispense cycle has been completed.

3.4 Software security and version control

3.4.1 The currently approved software version is “V.W.13”, which is displayed on the display panel at power-on.

3.4.2 The instrument has an electronic “audit trail” feature which is maintained in the software program for calibration of the unit.

3.4.3 Having an alternative software version ”V1.00”, which is displayed on the display panel at power-on. This is identical to version “V.W.13”.

3.4.4 Having alternative software versions identified as:- “V1.xx” where: V1 represents the legally relevant software, and “xx” represents changes to the non-legally relevant software.

4 LEGENDS

4.1 The following legends are marked on a tamper evident label positioned above every dispense point heads (Figure 8):

- manufacturer’s name,
- the certificate number
- quantity legend

5 AUTHORISED ALTERNATIVE

5.1 Having the addition of a 2 pint dispense volume. This is only available if a 2 pint integrated fob detector is used. This volume is identifiable through the LCD display and markings as described in section 4.1.

5.2 The ExacTap dispenser is also offered in a dual head dispenser. All outlined operational settings and features are the same as the singled head unit (Figure 2b).

5.3 The ExacTap dispenser is also offered as an ExacPour mobile unit with the head mounted directly onto the cooler (Figure 9). The standard layout is shown in figure 1b. This configuration is available for both the single and dual head. In this configuration the dispenser head may be powered from a 12 volt connection to the cooler unit.

5.4 Having an alternative mobile unit configuration as show in Figure 10.

5.5 Having **Drinks Dispense Group**, Lakeside House, Turnoaks Park, Burley Close, Chesterfield, Derbyshire, S40 2UB United Kingdom, as an alternative manufacturer.

5.6 Having an interactive $\frac{3}{4}$ pint capacity FoB (Figure 11) which detects the float dropping, when gas enters the vessel, and sends a signal to the head informing it that gas has entered the system or the keg has emptied. Depending on which “portion size” is selected, $\frac{1}{2}$ pint or pint, once the head receives the signal from the FoB it calculates how much product has been dispensed and how much more is required to complete the dispense. If it calculates that there is enough product left to complete the dispense it completes the pour then shuts down, if not it defaults to (the next) half pint and then shuts down.

5.7 Having an alternative sealing arrangement to secure the cover(s) of the headworks (Figure 12a). If the label is removed the adhesive backing remains (Figure 12b), so that the label cannot be re-applied.

6 RECOMMENDED TESTS

Installations of ‘ExacTap’ type systems have key components that should be checked before verification. These key components are temperature, flow rate and pressure.

6.1 The required temperature of the liquid from the dispenser is between 0 and 6 degrees Celsius.

6.2 The python length (distance between FOB and dispense head) should be no less than 1m of product line.

6.3 Reduce the keg top pressure (to below the specified pressure, typically 2.5 bar) until the low pressure cut-out operates. Verify that delivery stops and that the appropriate warning legend on the tap head indicates. Restore correct top pressure.

6.4 FOB – the ‘froth-on-beer’. Drain the FOB device until the float drops below the sensor device. Verify that delivery is inhibited and that the appropriate warning legend on the tap head indicates. Prime the FOB device to resume normal delivery.

Note: Due to the varied layout of installations, the FOB and keg may be some distance from the dispense point therefore making it difficult to check the operation of the FOB and low pressure sensors.

6.5 That on completion of the installation:

- the sealing described in section 2.3, including tamper evident seals, are in place;
- the delivery adjustment (authorised access) is no longer accessible;
- the tamper evident label bearing the: manufacturer’s name, certificate number and quantity legend is present on the instrument (section 4.1).

7 CONDITIONS

This certificate is issued subject to the following conditions:

7.1 The system is to be verified, after installation and commissioning, at the place of use and with the liquid that it is intended to dispense.

7.2 The top-up, head refresh, purge, keg refresh and stop features are disabled by setting the parameter values to zero in the set-up.

7.3 Once initiated, the delivery cannot be stopped by the operation of the STOP button.

7.4 The ExacPour mobile unit may be moved under the following conditions:

- It is verified and sealed with the liquid it is intended to dispense and with a keg to FOB product line length of between 3 and 25 meters, (figure 1c), it may then be used with any length of line within these limits.
- It is marked on the label in addition to the legends stated in Section 4.1;
“FOR USE WITH RUN LENGTHS BETWEEN 3 AND 25 METERS”.

7.5 The Interactive FoB, where fitted, is to be verified as operating as described in section 5.3.

- 8 ILLUSTRATIONS**
- Figure 1 Schematic of dual dispense system**
- Figure 2 ExacTap dispense heads**
- Figure 3 Control unit display panel**
- Figure 4 Cover variations**
- Figure 5 3 Piece Cover – Top Shroud Sealing**
- Figure 6 Example Seal**
- Figure 7 Flow regulator valve (integrated FOB)**
- Figure 8 Legend labels**
- Figure 9 ExacPour head and cooler configuration**
- Figure 10 Alternative mobile configuration**
- Figure 11 Interactive FoB**
- Figure 12 Alternative sealing for cover(s)**
- Figure 13 EX2200 Head**

8 CERTIFICATE HISTORY

ISSUE NO.	DATE	DESCRIPTION
2834	07 May 2008	Certificate first issued.
2834 Revision 1	18 September 2008	Certificate History added. Figure 1 Deleted, figures 1a, 1b and 1c added. References to each have been added in sections 1, 5.3 and 7.4 respectively. Section 3.4.3 added – Alternative software version.
2843 Revision 2	1 May 2009	Section 2.3.1 edited to include alternative DDg 2-piece fabricated cover. Section 3.4.4 added – Alternative software versions. Figures 2c and 4d added.
2843 Revision 3	11 August 2010	Revision 3 issued; Change of manufacturer details on page 1 Addition of section 5.4, Alternative manufacturer details. Modification to Figure 8 – to include alternative label Addition of Figure 10
2843 Revision 4	05 November 2010	Addition of sections 5.6, 5.7 and 7.5. Figure 2c : “EX2100” added to description Deletion of: Figures 4(b) DDg fabricated cover, and 4(c) NDT Oprema cover. Figure 4(d) renumbered as 4(b) and “DDg fabricated cover” replaced by “Stainless Steel head EX2100” Addition of Figures 11,12 & 13

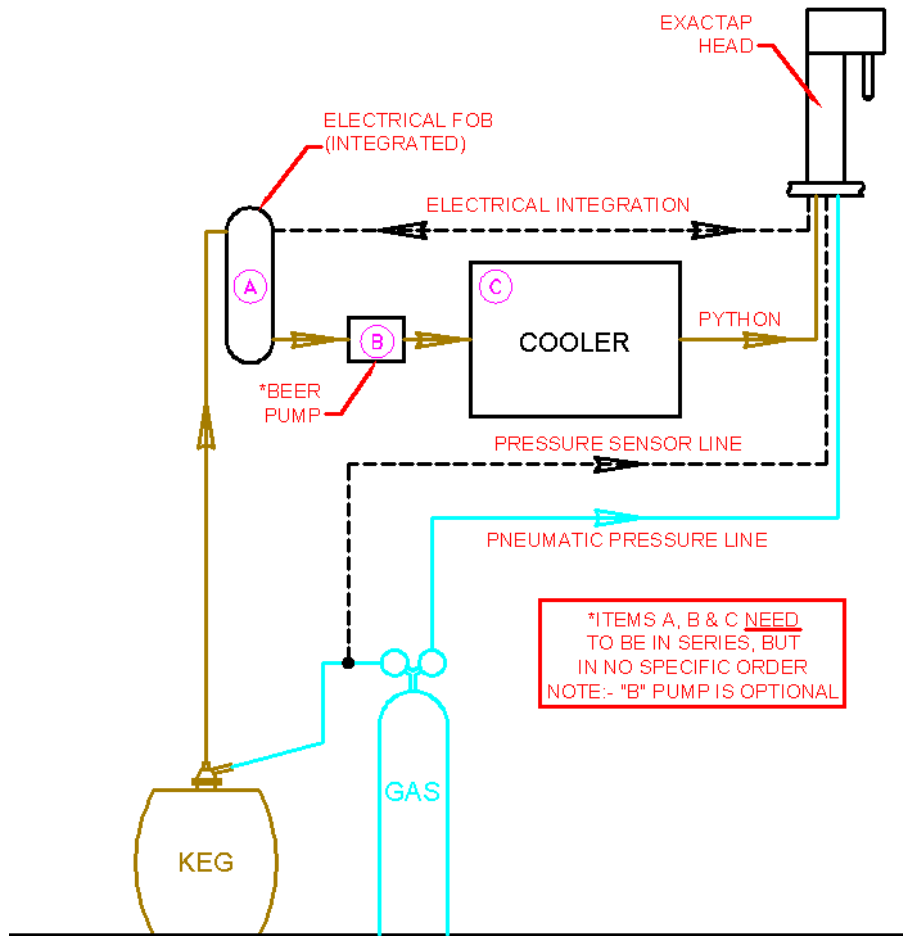

Figure 1a Schematic of Standard ExacTap dispense system

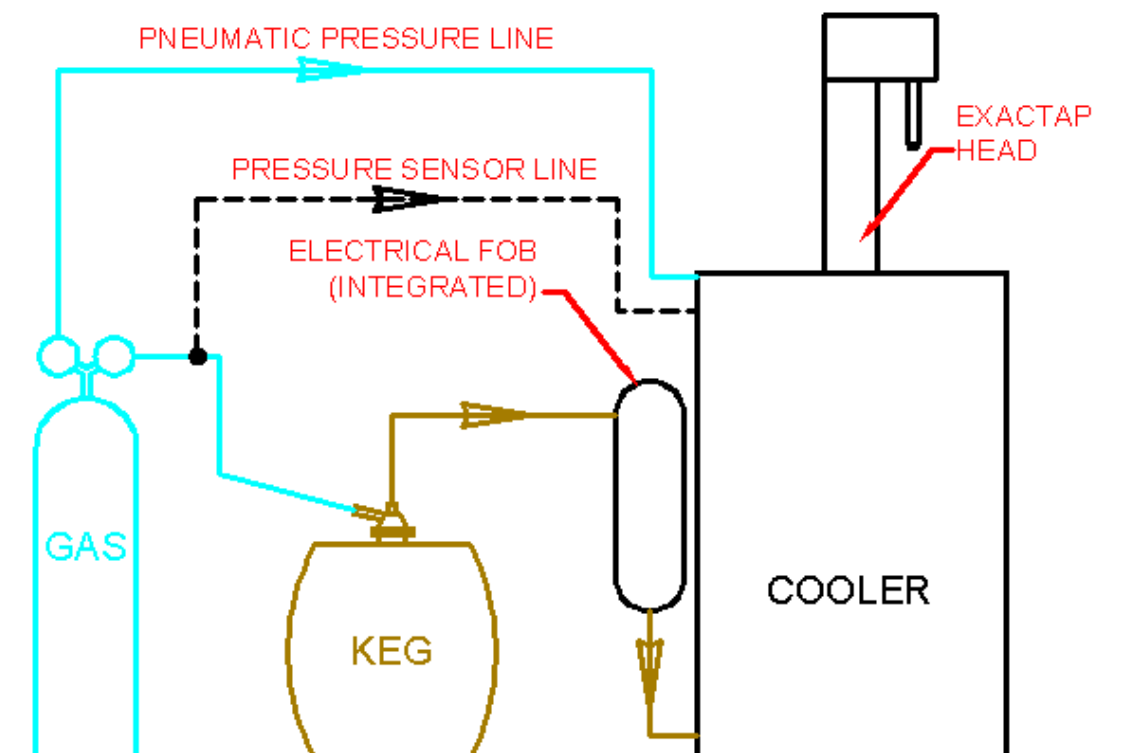

Figure 1b Schematic of Standard ExacPour cooler layout

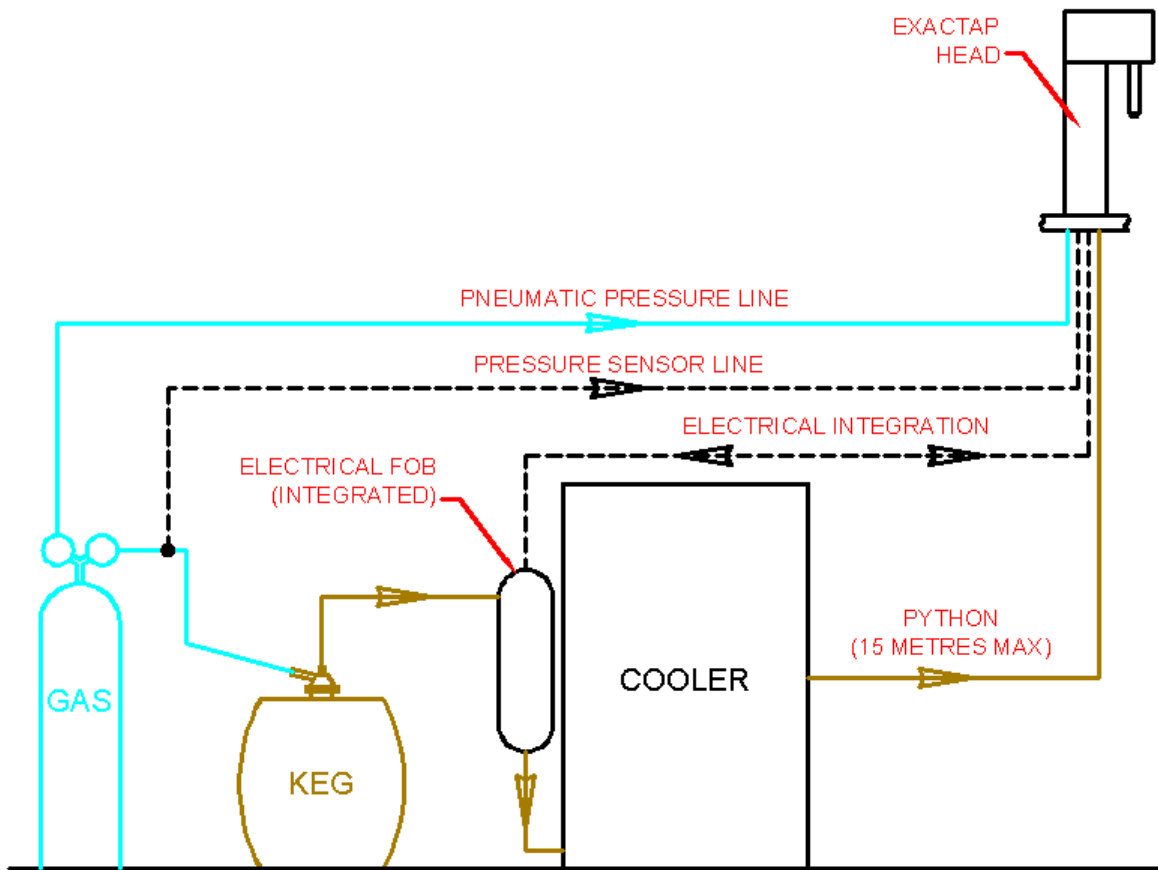

Figure 1c Schematic of ExacPour with remote cooler layout



**Figure 2a
Typical single dispense head**



**Figure 2b
Typical double dispense head**



Figure 2c
Alternative double dispense head EX2100













				
				
Volume Fill ½ Pint				Top up - disabled
Volume Fill 1 Pint				Foam creation - disabled
Volume Fill 2 Pints				Purge – Only accessible in management mode
Only accessible in Management mode		EX2000		Keg refresh
				

Figure 3
Control unit display panel



Figure 4a
NDT 3 piece plastic cover

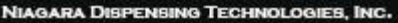

Figure 4b
Alternative Stainless Steel head EX2100



Figure 5 **Top Shroud Sealing**



Figure 6
Example Seal



Figure 7
Integrated FOB

Niagara Dispensing Technologies
METERED EXACTAP
Cert No 2843
To dispense HALF PINT or PINT

Figure 8a
Legend Label

Drinks Dispense Group Ltd
METERED EXACTAP
Cert No 2843
To dispense HALF PINT or PINT

Figure 8b
Alternative Legend Label



Figure 9
ExacPour head and cooler configuration



Figure 10
Alternative mobile configuration



Figure 11 **Interactive FoB**



Figure 12a Alternative sealing label



**Figure 12b Alternative sealing label
(removed)**



Figure 13 EX2200 Head