



Defence
Safety
Authority

AIR TRAFFIC MANAGEMENT (ATM)
3000 SERIES
REGULATORY ARTICLES

Military Aviation
Authority

Military Aviation Authority

MAA

Intentionally Blank for Pagination

3000 SERIES AIR TRAFFIC MANAGEMENT (ATM) REGULATORY ARTICLES (RA)

1. The ATM series of RA support the provision of Air Traffic Management and Aerodrome design and safeguarding. The series is split into 5 sub-sets:
 - a. The 3000 series covers the responsibilities of Defence Contractor Flying Organizations.
 - b. The 3100 series covers the ATM Approved Organization Scheme (AAOS) and ATM Equipment Regulations.
 - c. The 3200 and 3300 series cover the provision of ATM related services.
 - d. The 3500 series covers Aerodrome design and safeguarding.
2. The RA above are supported by 2 Manuals:
 - a. Manual of Military Air Traffic Management.
 - b. Manual of Military Air Traffic Management Equipment Assurance.
3. The 3000 Series (ATM) RA are owned by Director MAA. Table 1 below shows the current RA, along with the associated sub-Regulation titles.
4. Table 2 below shows withdrawn RAs, along with the associated sub-Regulation numbers and reasons for withdrawal. The withdrawal references provided were correct at the time of withdrawal but, it is incumbent on the user to check that they remain valid prior to use.

Table 1: 3000 Series (ATM) Regulatory Articles

| RA NUMBER | RA DESCRIPTION | SUB RA |
|------------------|---|--|
| RA 3049 | Defence Contractor Flying Organization responsibilities for UK Military Air System Operating Locations | 3049(1): Defence Contractor Flying Organization Operating Location Requirement |
| | | 3049(2): Defence Contractor Flying Organization Operating Location Support Services |
| RA 3100 | Air Traffic Management Equipment Approved Organization Scheme | 3100(1): Air Traffic Management Equipment Approved Organization Scheme Application and Approval |
| | | 3100(2): Air Traffic Management Equipment Approved Organization Scheme Approval Changes |
| | | 3100(3): Air Traffic Management Equipment Organization Exposition |
| | | 3100(4): Air Traffic Management Equipment Approved Organization Scheme MAA Regulatory Publications Applicability |
| | | 3100(5): Contracted / Subcontracted Activities |
| RA 3102 | Air Traffic Management Equipment Approved Organization Scheme Accountable Manager | 3102(1): Roles and Responsibilities of the Air Traffic Management Equipment Approved Organization Scheme Accountable Manager |
| RA 3104 | Air Traffic Management Equipment Approved Organization Scheme – Maintenance Records | 3104(1): Recording of Maintenance Work |
| | | 3104(2): Retention of Maintenance Records |
| RA 3105 | Air Traffic Management Equipment Approved Organization Scheme – Maintenance Documentation | 3105(1): Approved, Current and Applicable Technical Information |
| | | 3105(2): Withdrawn – Incorporated into RA 3105(1) |
| | | 3105(3): Withdrawn – Incorporated into RA 3105(7) |

| RA NUMBER | RA DESCRIPTION | SUB RA |
|-----------|--|---|
| | | 3105(4): Withdrawn – Incorporated into RA 3105(8) 3105(5): Withdrawn – Incorporated into RA 3105(1) 3105(6): Withdrawn – Incorporated into RA 3105(1) 3105(7): Amendments to Technical Information 3105(8): Maintenance Documentation |
| RA 3106 | Air Traffic Management Equipment Approved Organization Scheme – Maintenance Practices | 3106(1): Air Traffic Management Equipment Approved Organization Scheme Maintenance Practices |
| RA 3107 | Air Traffic Management Equipment Approved Organization Scheme – Equipment, Tools and Material | 3107(1): Equipment, Tools and Material 3107(2): Control of Equipment, Tools and Material |
| RA 3108 | Air Traffic Management Equipment Approved Organization Scheme – Occurrence Reporting | 3108(1): Unsafe Condition Reporting 3108(2): Internal Occurrence Reporting 3108(3): MOD Sponsored Reporting Action |
| RA 3120 | Air Traffic Management Equipment Standards | 3120(1): Air Traffic Management Equipment Standards |
| RA 3130 | Air Traffic Management (ATM) Equipment Safety Management | 3130(1): Project/Delivery Team Leader (PTL/DTL) Responsibilities 3130(2): User/Operator Responsibilities 3130(3): Legislation Compliance 3130(4): Configuration Management 3130(5): Safety Documentation Retention 3130(6): Independent Safety Auditor (ISA) 3130(7): ATM Equipment Risk Classification 3130(8): ATM Equipment Risk Management |
| RA 3132 | Air Traffic Management Equipment Safety Cases | 3132(1): Air Traffic Management Equipment Safety Cases 3132(2): Responsibilities of Duty Holder-Facing Organizations 3132(3): Air Traffic Management Equipment Safety Case Management Process 3132(4): Air Traffic Management Equipment Safety Case Amendments 3132(5): Air Traffic Management Equipment Safety Case Reports |

| RA NUMBER | RA DESCRIPTION | SUB RA |
|-----------|--|---|
| | | 3132(6): Air Traffic Management Equipment Safety Case Independent Assessment |
| | | 3132(7): Specific Site / Operating Area Safety |
| RA 3134 | Air Traffic Management Equipment Release into Service Process | 3134(1): Air Traffic Management Equipment Release into Service Process |
| | | 3134(2): Release into Service Strategy |
| | | 3134(3): Release into Service Exposition |
| | | 3134(4): Withdrawn - Incorporated into RA 3134(3) |
| | | 3134(5): Air Traffic Management Equipment Acceptance Board |
| | | 3134(6): Site Specific Acceptance and Commissioning Board |
| | | 3134(7): Release into Service Process Audit Trail |
| RA 3136 | Air Traffic Management Equipment Technical Safeguarding | 3136(1): Head of Establishment / Duty Holder-Facing Organizations' Responsibilities |
| | | 3136(2): Ministry of Defence Radio Site Protection Programme Manager Responsibilities |
| | | 3136(3): Air Traffic Management Equipment Engineering Authority Responsibilities |
| | | 3136(4): Headquarters Responsibilities |
| | | 3136(5): Aviation Duty Holder Responsibilities – Operating within an infringed Air Traffic Management Equipment environment |
| RA 3140 | Air Traffic Management (ATM) Equipment End to End Safety | 3140(1): Interfaces |
| | | 3140(2): Justification of ATM Equipment Safety Case (SC) Assumptions |
| | | 3140(3): Front Line Command Formal Agreements |
| RA 3201 | Military Air Traffic Management | 3201(1): Military Air Traffic Management |
| RA 3202 | Entitlement to provide Air Traffic Services, an Air Ground Communication Service (Military) or use Air Ground Radios and Air Traffic Management Equipment | 3202(1): Qualifications and Entitlement to provide Air Traffic Services |
| | | 3202(2): Controller Training |
| | | 3202(3): Controller Periodicity of Assessment of Competence |
| | | 3202(4): Controller Currency |
| | | 3202(5): Qualifications, Training, Competence and Currency to provide an Air Ground Communication Service (Military) |
| | | 3202(6): Training and Competence to transmit to Aircraft on Air Ground Radios |
| | | 3202(7): Use of Air Traffic Management Equipment and Data |
| RA 3203 | | 3203(1): Controller Medical Certificate |

| RA NUMBER | RA DESCRIPTION | SUB RA |
|-----------|---|---|
| | Military and MOD Contracted Civilian Controller Medical Requirements | 3203(2): Controller Fitness-to-Control |
| | | 3203(3): Controller Operations – Upper Age Restrictions |
| | | 3203(4): Temporary Medical Restrictions to Controlling Duties |
| | | 3203(5): Blood Donation and Controlling Duties |
| RA 3204 | Air Traffic Management Records | 3204(1): Air Traffic Management Records |
| RA 3205 | Radar Analysis Cell | 3205(1): Radar Analysis Cell |
| RA 3206 | Air Traffic Management Equipment Checks | 3206(1): Air Traffic Management Equipment Checks |
| RA 3207 | Controller Fatigue Management | 3207(1): Controller Fatigue Management |
| RA 3208 | Use of Unassured Aircraft Surveillance Data by Controllers | 3208(1): Use of Unassured Aircraft Surveillance Data |
| | | 3208(2): User Training |
| RA 3221 | Enhanced Air Traffic Services Units | 3221(1): Enhanced Air Traffic Services Units |
| RA 3222 | Autonomous Radar Units | 3222(1): Autonomous Radar Units |
| RA 3223 | Provision of Air Traffic Service Inside Controlled Airspace | 3223(1): Provision of Air Traffic Service Inside Controlled Airspace |
| RA 3224 | UK Flight Information Services (FIS) | 3224(1): UK Flight Information Services (FIS) |
| RA 3225 | Mandatory Air Traffic Control Instructions | 3225(1): Mandatory Air Traffic Control Instructions |
| RA 3226 | Secondary Surveillance Radar (SSR) | 3226(1): Validation of Mode 3/A Codes |
| | | 3226(2): Verification of Mode C Data |
| | | 3226(3): Level Occupancy using Secondary Surveillance Radar |
| RA 3227 | Methods of Identification | 3227(1): Methods of Identification |
| RA 3228 | Separation Standards | 3228(1): Separation Requirements |
| | | 3228(2): Separation Standards – Lateral |
| | | 3228(3): Separation Standards – Vertical |
| | | 3228(4): Separation Standards for Aircraft Operating in Controlled Airspace |
| | | 3228(5): Vertical Separation Standards For Typhoon |
| | | 3228(6): Separation Standards for Radar to Visual Recoveries |
| RA 3229 | Traffic Information between Air Traffic Service (ATS) Providers | 3229(1): Traffic Information between ATS Providers |

| RA NUMBER | RA DESCRIPTION | SUB RA |
|-----------|--|---|
| RA 3230 | Traffic Coordination | 3230(1): Traffic Coordination |
| | | 3230(2): Approved Methods of Coordination |
| RA 3231 | Air Traffic Control Unit Terrain Safe Level and Terrain Clearance | 3231(1): Air Traffic Control Unit Terrain Safe Level |
| | | 3231(2): Controllers' Responsibility for Terrain Clearance |
| RA 3232 | Provision of Vectors to Aircraft conducting Radar to Visual Recoveries or Short Pattern Circuits below the Air Traffic Control Unit Terrain Safe Level | 3232(1): Provision of Vectors to Aircraft conducting Radar to Visual Recoveries or Short Pattern Circuits below the Air Traffic Control Unit Terrain Safe Level |
| RA 3233 | Conduct of Radar Handovers | 3233(1): Conduct of Radar Handovers |
| RA 3234 | Air System Formations | 3234(1): Air System Formations |
| RA 3235 | Airborne Collision Avoidance Systems and Terrain Awareness and Warning Systems - Controller Responsibilities | 3235(1): ACAS – Controller Responsibilities |
| | | 3235(2): Terrain Awareness and Warning Systems – Controller Responsibilities |
| RA 3236 | Clutter on Situational Displays | 3236(1): Clutter on Situational Displays |
| RA 3237 | Royal Low Level Corridors | 3237(1): Royal Low Level Corridors |
| RA 3239 | Aircraft Conducting Transits to / from Ships and Aerodromes | 3239(1): Departure Messages |
| | | 3239(2): Operating Requirements |
| RA 3240 | Contingency Operations for Simultaneous Failure of Surveillance Radars and / or Air Traffic Management Communication Systems | 3240(1): Surveillance Radar and Air Traffic Management Communications Contingency Operations |
| | | 3240(2): Withdrawn – Detail in RA 1020 |
| RA 3241 | Secondary Surveillance Radar Alone Operations | 3241(1): Secondary Surveillance Radar Alone Operations |
| | | 3241(2): Secondary Surveillance Radar Alone Contingency Operations |
| | | 3241(3): Withdrawn – Detail in RA 1020 |
| RA 3261 | Aerodrome Service | 3261(1): Aerodrome Service |
| | | 3261(2): Aerodrome Emergency Services |
| | | 3261(3): Aerodrome Service in Class D Airspace |
| RA 3262 | Aerodrome Access | 3262(1): Aerodrome Access |
| RA 3263 | Aerodrome Classification | 3263(1): Aerodrome Classification |
| RA 3264 | Aerodrome Inspections | 3264(1): Aerodrome Inspections |

| RA NUMBER | RA DESCRIPTION | SUB RA |
|-----------|---|---|
| RA 3265 | Aerodrome Lighting Operating Requirements | 3265(1): Aerodrome Lighting Operating Requirements |
| | | 3265(2): Night Vision Devices Operating Requirements |
| RA 3266 | Aerodrome Maintenance | 3266(1): Aerodrome Maintenance |
| | | 3266(2): Work In Progress Map |
| RA 3267 | Aerodrome Vehicle Marking and Lighting Requirements | 3267(1): Aerodrome Vehicle Marking and Lighting Requirements |
| RA 3268 | Aircraft Arresting Systems | 3268(1): Aircraft Arresting Systems |
| | | 3268(2): Aircraft Arresting Systems - Barriers – Controller Responsibilities |
| | | 3268(3): Aircraft Arresting Systems - Cables – Controller Responsibilities |
| RA 3269 | Use of Pyrotechnics, Firearms and Lasers to Support Aerodrome Operations | 3269(1): Use of Pyrotechnics, Firearms and Lasers to Support Aerodrome Operations |
| RA 3270 | Aerodrome Wildlife Control | 3270(1): Aerodrome Wildlife Control |
| RA 3272 | Evaluation of Runway Surface Conditions | 3272(1): Continuous Friction Measuring Equipment |
| | | 3272(2): Reporting of Runway Surface Conditions |
| RA 3273 | Aerodrome Traffic Monitor | 3273(1): Aerodrome Traffic Monitor |
| RA 3274 | Low Visibility Procedures | 3274(1): Low Visibility Procedures |
| RA 3275 | Runway Visual Range (RVR) | 3275(1): Provision of RVR/Instrumented RVR (IRVR) |
| | | 3275(2): Provision of Human Observed RVR |
| RA 3277 | Wake Turbulence | 3277(1): Wake Turbulence |
| RA 3278 | Snow and Ice Operations | 3278(1): Snow and Ice Operations |
| | | 3278(2): Withdrawn – Incorporated into RA 3278(1) |
| RA 3279 | Aircraft Last Look Checks | 3279(1): Requirement for Aircraft Last Look Checks |
| | | 3279(2): Establishment of Aircraft Last Look Checks |
| | | 3279(3): Provision of Aircraft Last Look Checks |
| | | 3279(4): Equipment and Operating Requirements – Truck Runway Control |
| | | 3279(5): Equipment and Operating Requirements – Digital Aircraft Last Look Checks |
| RA 3291 | Precision Approach Radar | 3291(1): Precision Approach Radar |
| | | 3291(2): Precision Approach Radar for Civil Pilots |

| RA NUMBER | RA DESCRIPTION | SUB RA |
|-----------|--|--|
| RA 3292 | Instrument Landing Systems (ILS) Monitoring | 3292(1): ILS Monitoring |
| RA 3293 | Surveillance Radar Approach | 3293(1): Surveillance Radar Approach |
| RA 3295 | Required Navigation Performance Approach – Controller Responsibilities | 3295(1): Required Navigation Performance Approach - Controller Responsibilities |
| RA 3301 | Meteorological (Met) Information | 3301(1): Met Information |
| | | 3301(2): Met Information Requirements |
| RA 3302 | Altimeter Settings | 3302(1): Altimeter Settings |
| RA 3311 | Aircraft Emergency and Crash Procedures | 3311(1): Aircraft Emergency and Crash Procedures |
| RA 3312 | Overdue Action by Air Traffic Control | 3312(1): Overdue Action by Air Traffic Control |
| RA 3313 | Air System Diversions | 3313(1): Air System Diversions |
| RA 3500 | Aerodrome Design and Safeguarding | 3500(1): Aerodrome Design and Safeguarding |
| RA 3510 | Permanent Fixed Wing Aerodrome - Reference Information | 3510(1): Common Reference System |
| | | 3510(2): Reference Codes |
| | | 3510(3): Aerodrome Data |
| RA 3511 | Permanent Fixed Wing Aerodrome - Physical Characteristics | 3511(1): Pavement - Characteristics |
| | | 3511(2): Runway - Number, Siting and Orientation |
| | | 3511(3): Runway - Dimensions |
| | | 3511(4): Runway - Characteristics |
| | | 3511(5): Runway - Runway-End Safety Areas |
| | | 3511(6): Taxiway - Characteristics |
| | | 3511(7): Aprons |
| RA 3512 | Permanent Fixed Wing Aerodrome - Obstacle Environment | 3512(1): Obstacle Limitation Surfaces |
| | | 3512(2): Obstacle Free Zones |
| | | 3512(3): Obstacle Limitation Surfaces Requirements - Non-Instrument Runways |
| | | 3512(4): Obstacle Limitation Surfaces Requirements - Non-Precision Approach Runways |
| | | 3512(5): Obstacle Limitation Surfaces Requirements - Precision Approach (Cat I) Runways |
| | | 3512(6): Obstacle Limitation Surfaces Requirements - Precision Approach (Cat II/III) Runways |
| | | 3512(7): Runways Meant For Take-Off |
| | | 3512(8): Objects Outside the Obstacle Limitation Surfaces |

| RA NUMBER | RA DESCRIPTION | SUB RA |
|-----------|---|--|
| RA 3513 | Permanent Fixed Wing Aerodrome - Indicators and Signalling Devices | 3513(1): Wind Direction Indicator |
| | | 3513(2): Landing Direction Indicator |
| | | 3513(3): Aerodrome Identification |
| | | 3513(4): Signalling Lamp |
| RA 3514 | Permanent Fixed Wing Aerodrome - Markings | 3514(1): General Markings |
| | | 3514(2): Runway Markings |
| | | 3514(3): Aiming Point and Touchdown Zone Markings |
| | | 3514(4): Taxiway Markings |
| | | 3514(5): Vehicle Roadway Markings |
| | | 3514(6): Air System Stand Markings |
| | | 3514(7): Arrestor System Markings |
| | | 3514(8): Mandatory Instruction Markings |
| | | 3514(9): Information Markings |
| RA 3515 | Permanent Fixed Wing Aerodrome - Lighting | 3515(1): Lighting - Scaling |
| | | 3515(2): Lighting - Dangerous or Confusing Lights |
| | | 3515(3): Approach Lighting - Obstacle Profile |
| | | 3515(4): Aeronautical Beacons - Identification Beacons |
| | | 3515(5): Approach Lighting - Simple Approach Lighting System |
| | | 3515(6): Approach Lighting - High Intensity Centre-Line and Crossbar Approach System |
| | | 3515(7): Approach Lighting - Supplementary Approach Lighting |
| | | 3515(8): Approach Lighting - Precision Approach Path Indicator |
| | | 3515(9): Runway Lights - Runway Edge Lights |
| | | 3515(10): Runway Lights - Runway Threshold Lights |
| | | 3515(11): Runway Lights - Runway Threshold Wing Bar Lights |
| | | 3515(12): Runway Lights - Runway End Lights |
| | | 3515(13): Runway Lights - Runway Centre-Line Lights |
| | | 3515(14): Runway Lights - Runway Touchdown Zone Lights |
| | | 3515(15): Runway Lights - Stopway Lights |
| | | 3515(16): Taxiway Lights - Taxiway Centre-Line Lights |
| | | 3515(17): Taxiway Lights - Taxiway Edge Lights |
| | | 3515(18): Taxiway Lights - Stop Bar Lights |
| | | 3515(19): Taxiway Lights - Runway Guard Lights |
| | | 3515(20): Taxiway Lights - Road-Holding Position Lights |

| RA NUMBER | RA DESCRIPTION | SUB RA |
|-----------|---|---|
| | | 3515(21): Apron Lights - Edge Lighting 3515(22): Apron Lights - Floodlighting 3515(23): Miscellaneous Lights - Undercarriage Inspection Systems 3515(24): Miscellaneous Lights - Arrestor Cable Systems and Illuminated Runway Distance to go Markers 3515(25): Miscellaneous Lights - Visual Docking Guidance System 3515(26): Miscellaneous Lights - Advanced Visual Docking Guidance System 3515(27): Miscellaneous Lights - Emergency Portable Lighting 3515(28): Aeronautical Ground Lights Characteristics - Construction 3515(29): Aeronautical Ground Lights Characteristics - Intensity and Distribution 3515(30): Aeronautical Ground Lights Characteristics - Colour and Discrimination |
| RA 3516 | Permanent Fixed Wing Aerodrome - Signs | 3516(1): General 3516(2): Mandatory Instruction Signs 3516(3): Information Signs 3516(4): Aerodrome Access Boards |
| RA 3517 | Permanent Fixed Wing Aerodrome - Markers | 3517(1): General 3517(2): Unpaved Runway Edge Markers 3517(3): Stopway Edge Markers 3517(4): Edge Markers for Snow-Covered Runways 3517(5): Paved Taxiway Edge Markers 3517(6): Taxiway Centre-Line Markers 3517(7): Unpaved Taxiway Edge Markers 3517(8): Boundary Markers 3517(9): Arrestor System Markers 3517(10): Distance To Go Markers |
| RA 3518 | Permanent Fixed Wing Aerodrome - Visual Aids for Denoting Obstacles | 3518(1): Objects Within the Obstacle Limitation Surfaces 3518(2): Objects Outside the Obstacle Limitation Surfaces 3518(3): Marking of Objects - General 3518(4): Marking of Objects - Use of Colour 3518(5): Marking of Objects - Use of Markers and Flags 3518(6): Marking of Objects - Mobile Objects |

| RA NUMBER | RA DESCRIPTION | SUB RA |
|-----------|---|---|
| | | 3518(7): Lighting of Objects - General 3518(8): Lighting of Objects - Location and Number of Lights 3518(9): Lighting of Wind Turbines 3518(10): Lighting of Overhead Wires, Cables and Supporting Towers 3518(11): Lighting of Mobile Objects 3518(12): Lighting of Air System Arresting Barriers |
| RA 3519 | Permanent Fixed Wing Aerodrome - Visual Aids for Denoting Restricted Use Areas | 3519(1): Closed Runways and Taxiways 3519(2): Hazardous Areas 3519(3): Unserviceable Areas |
| RA 3520 | Permanent Fixed Wing Aerodrome - Aerodrome Electrical Systems | 3520(1): Aerodrome Electrical System Design 3520(2): Interleaving Aerodrome Ground Lighting 3520(3): Truck Runway Control Electrical Services |
| RA 3521 | Permanent Fixed Wing Aerodrome - Facilities | 3521(1): Air System Arresting Systems 3521(2): Runway Visual Range Systems 3521(3): Compass Calibration Bases - Classes 3521(4): Compass Calibration Bases - Construction 3521(5): De-icing / Anti-icing |
| RA 3522 | RA 3522 – Permanent Fixed Wing Aerodrome – Vertical Landing Pads | 3522(1): Physical Characteristics 3522(2): Obstacle Environment 3522(3): Markings 3522(4): Lighting 3522(5): Signs |
| RA 3530 | Helicopter Landing Site - Reference Information | 3530(1): Helicopter Landing Sites Regulatory Framework 3530(2): Permanent Helicopter Landing Sites - Common Reference System 3530(3): Permanent Helicopter Landing Sites - Helicopter Performance Class 3530(4): Permanent Helicopter Landing Sites - Aeronautical Data |
| RA 3531 | Helicopter Landing Site - Physical Characteristics | 3531(1): Permanent Helicopter Landing Site - Final Approach and Take Off area 3531(2): Permanent Helicopter Landing Site - Clearway 3531(3): Permanent Helicopter Landing Site - Touchdown and Lift Off area 3531(4): Permanent Helicopter Landing Site - Safety Area 3531(5): Permanent Helicopter Landing Site - Ground Taxiway |

| RA NUMBER | RA DESCRIPTION | SUB RA |
|-----------|---|--|
| | | 3531(6): Permanent Helicopter Landing Site - Air Taxiway 3531(7): Permanent Helicopter Landing Site - Air Transit Route - Design 3531(8): Permanent Helicopter Landing Site - Apron 3531(9): ► Withdrawn – Incorporated into RA 3536(1): Domestic Helicopter Landing Sites – General Requirements ◀ |
| RA 3532 | Helicopter Landing Site - Obstacle Environment | 3532(1): Permanent Helicopter Landing Sites - Obstacle Limitation Surfaces (General) 3532(2): Permanent Helicopter Landing Sites - Obstacle Limitation Surfaces for Non-Instrument Approach 3532(3): Permanent Helicopter Landing Sites - Obstacle Limitation Surfaces for Precision or Non-Precision Approach 3532(4): Permanent Helicopter Landing Sites - Obstacle Limitation Surfaces for Visual Approach Slope Indicator 3532(5): ► Withdrawn – Incorporated into RA 3536(1): Domestic Helicopter Landing Sites – General Requirements ◀ 3532(6): ► Withdrawn – Incorporated into RA 3536(1): Domestic Helicopter Landing Sites – General Requirements ◀ |
| RA 3533 | Helicopter Landing Site - Indicators and Signalling Devices | 3533(1): Helicopter Landing Sites - Wind Direction Indicator 3533(2): Permanent Helicopter Landing Sites - Aerodrome Identification |
| RA 3534 | Helicopter Landing Site - Markings | 3534(1): Helicopter Landing Site Identification Markings 3534(2): Permanent Helicopter Landing Site - Final Approach and Take Off Dimensions and Markings 3534(3): Permanent Helicopter Landing Site - Aiming Point Markings 3534(4): Permanent Helicopter Landing Site - Touchdown and Lift Off Markings 3534(5): Permanent Helicopter Landing Site - Touchdown/Positioning Markings 3534(6): Permanent Helicopter Landing Site - Air Taxiway Markers and Markings 3534(7): Permanent Helicopter Landing Site - Air Taxi Route Markers 3534(8): Permanent Helicopter Landing Site - Helicopter Stand Markings 3534(9): Permanent Helicopter Landing Site - Flight Path Alignment Guidance Marking |
| RA 3535 | Helicopter Landing Site - Lighting | 3535(1): Permanent Helicopter Landing Site - Lighting 3535(2): Permanent Helicopter Landing Site - Approach Lights 3535(3): Permanent Helicopter Landing Site - Approach Guidance Systems |

| RA NUMBER | RA DESCRIPTION | SUB RA |
|-----------|---|--|
| | | 3535(4): Permanent Helicopter Landing Site - Helipad Lights 3535(5): Permanent Helicopter Landing Site - Air Transit Route Lights 3535(6): Permanent Helicopter Landing Site - Aeronautical Ground Lights Characteristics 3535(7): ► Withdrawn – Incorporated into RA 3536(1): Domestic Helicopter Landing Sites – General Requirements ◀ |
| RA 3536 | RA 3536 - Domestic Helicopter Landing Site ► ◀ | 3536(1): Domestic Helicopter Landing Site – ► General Requirements ◀ 3536(2): Domestic Helicopter Landing Site – ► Classification and Specific Requirements ◀ 3536(3): Domestic Helicopter Landing Site ► Custodian – Responsibilities ◀ ► 3636(4): Domestic Helicopter Landing Site Custodian – Qualifications and Experience ◀ |
| RA 3550 | Temporary Landing Zone | 3550(1): Temporary Landing Zone 3550(2): Temporary Landing Zone Establishment |
| RA 3590 | Maintenance and Safeguarding | 3590(1): Maintenance - General 3590(2): Maintenance - Pavements - Friction 3590(3): Maintenance - Pavements - Inspection 3590(4): Maintenance - Pavements - Removal of Contaminants 3590(5): Maintenance - Inspections - Measured Height Surveys 3590(6): Maintenance - Inspections - Compass Calibration Bases Periodic Surveys and Annual Checks 3590(7): Maintenance - Visual Aids 3590(8): Safeguarding - MOD Property 3590(9): Safeguarding - Outside MOD Property 3590(10): Safeguarding - Surface Obstructions 3590(11): Safeguarding - Sub-Surface Obstructions 3590(12): Safeguarding - Operationally Essential Obstructions |
| | Manual of Military Air Traffic Management (MMATM) | |

Table 2: Withdrawn 3000 Series (ATM) Regulatory Articles (not included in the 3000 Series combined document)

| RA NUMBER | RA DESCRIPTION | SUB RA |
|------------------|--|---|
| RA 3001 | Military ATC Policy | 3001(1): Replaced by RA 3201 - Military ATM |
| RA 3003 | Responsibilities of ATC Personnel | 3003(1): Withdrawn - Not deemed regulatory material. May be included in Single Service Instructions/Order Books as required |
| | | 3003(2): Withdrawn - Not deemed regulatory material. May be included in Single Service Instructions/Order Books as required |
| | | 3003(3): Withdrawn - Not deemed regulatory material. Process included in MMATM |
| | | 3003(4): Replaced by RA 3203 - Medical Requirements |
| | | 3003(5): Replaced by RA 3203(4) - Blood Donations and ATC Duties |
| | | 3003(6): Subsumed within Armed Forces Act 2006 as amended by the Armed Forces Act 2011 Effective 1 Nov 13 |
| | | 3003(7): Replaced by RA 3203(3) - Temporary Medical Restrictions to Controlling Duties |
| RA 3004 | Division of Airspace & Rules of the Air | 3004(1): Withdrawn - Details in UK AIP/Mil AIP |
| | | 3004(2): Withdrawn - Details in UK AIP/Mil AIP |
| | | 3004(3): Withdrawn - Details in UK AIP/Mil AIP |
| | | 3004(4): Withdrawn - Details in UK AIP/Mil AIP |
| | | 3004(5): Withdrawn - Details in UK AIP/Mil AIP |
| | | 3004(6): Withdrawn - Details in UK AIP/Mil AIP |
| | | 3004(7): Withdrawn - Moved to 2000 Series RA's |
| | | 3004(8): Withdrawn - Details in RA 3231 - Terrain Safe Level and Terrain Clearance and MMATM |
| | | 3004(9): Withdrawn - Not regulatory. Pilot elements covered in 2000 Series RA's |
| | | 3004(10): Withdrawn - Moved to 2000 Series RA's |
| | | 3004(11): Withdrawn - Moved to 2000 Series RA's |
| | | 3004(12): Withdrawn - Moved to 2000 Series RA's |
| RA 3005 | Altimetry | 3005(1): Replaced by RA 3302 - Altimetry |
| | | 3005(2): Replaced by RA 3302 - Altimetry |
| | | 3005(3): Replaced by RA 3302 - Altimetry |
| | | 3005(4): Replaced by RA 3302 - Altimetry |
| RA 3006 | Notification and Conduct of Flights | 3006(1): Withdrawn - Details in UK AIP |

| RA NUMBER | RA DESCRIPTION | SUB RA |
|-----------|--|---|
| | | 3006(2): Withdrawn - Details in UK AIP |
| | | 3006(3): Withdrawn - Details in UK AIP |
| RA 3007 | Unusual Aerial Activities | 3007(1): Withdrawn - Details in UK AIP |
| | | 3007(2): Withdrawn - Details in Air Navigation Order (CAP 393) |
| | | 3007(3): Withdrawn - Details in UK AIP |
| RA 3008 | Methods of Identification | 3008(1): Withdrawn - Details in Air Navigation Order (CAP 393) |
| RA 3009 | Radar Handover Procedures | 3009(1): Replaced by RA 3233 - Conduct of Radar Handover |
| RA 3010 | Traffic Information and Traffic Coordination | 3010(1): Replaced by RA 3229 - Traffic Information between ATS Providers and RA 3230 - Traffic Coordination |
| RA 3011 | Types of Service and Separation Standards | 3011(1): Replaced by RA 3223 - Provisions of Air Traffic Service Inside CAS |
| | | 3011(2): Replaced by RA 3224 - Flight Information Services Outside CAS |
| | | 3011(3): Replaced by RA 3229 - Traffic Information between ATS Providers |
| | | 3011(4): Replaced by RA 3229 - Traffic Information between ATS Providers |
| | | 3011(5): Replaced by RA 3228(1) - Standard Separation – Lateral |
| | | 3011(6): Replaced by RA 3228(1) - Standard Separation – Lateral |
| | | 3011(7): Replaced by RA 3228(2) - Standard Separation - Vertical |
| | | 3011(8): Replaced by RA 3228(2) - Standard Separation - Vertical |
| | | 3011(9): Replaced by RA 3228(2) - Standard Separation - Vertical |
| | | 3011(10): Replaced by RA 3228(3) - Vertical Separation Standards for Typhoon |
| | | 3011(11): Replaced by RA 3234 - Air System Formations |
| | | 3011(12): Replaced by RA 3294 - Reporting of Hazardous Flying Conditions |
| | | 3011(13): Replaced by RA 3236 - Clutter on Situational Displays |
| RA 3012 | General Operating Procedures | 3012(1): Replaced by RA 3236 - Clutter on Situational Displays |
| | | 3012(2): Replaced by RA 3231 - Terrain Safe Level and Terrain Clearance |
| | | 3012(3): Withdrawn - Not deemed regulatory material. Process in MMATM |

| RA NUMBER | RA DESCRIPTION | SUB RA |
|-----------|--|---|
| | | 3012(4): Replaced by RA 3277 - Wake Turbulence |
| | | 3012(5): Withdrawn - Details in UK AIP |
| RA 3013 | Airborne Collision Avoidance Systems | 3013(1): Replaced by RA 3235 - Airborne Collision Avoidance Systems (ACAS) – Controller Responsibilities |
| | | 3013(2): Replaced by RA 3235 - Airborne Collision Avoidance Systems (ACAS) – Controller Responsibilities |
| | | 3013(3): Replaced by RA 3235 - Airborne Collision Avoidance Systems (ACAS) – Controller Responsibilities |
| RA 3014 | Meteorological Information | 3014(1): Replaced by RA 3301 - Meteorological (Met) Information |
| | | 3014(2): Replaced by RA 3301 - Meteorological (Met) Information |
| | | 3014(3): Replaced by RA 3301 - Meteorological (Met) Information |
| | | 3014(4): Replaced by RA 3301 - Meteorological (Met) Information |
| | | 3014(5): Replaced by RA 3275 - Runway Visual Range (RVR) |
| RA 3015 | Royal Flights | 3015(1): Majority withdrawn – Detail was out of date. Current information in UK AIP. Regulatory Material covered in RA 3237 – Royal Low Level Corridors |
| | | 3015(2): Majority withdrawn – Detail was out of date. Current information in UK AIP. Regulatory Material covered in RA 3237 – Royal Low Level Corridors |
| | | 3015(3): Majority withdrawn – Detail was out of date. Current information in UK AIP. Regulatory Material covered in RA 3237 – Royal Low Level Corridors |
| | | 3015(4): Majority withdrawn – Detail was out of date. Current information in UK AIP. Regulatory Material covered in RA 3237 – Royal Low Level Corridors |
| RA 3016 | Military Aerodrome Design and Safeguarding Criteria | 3016(1): Replaced by RA 3263 Aerodrome Classification |
| | | 3016(2): Withdrawn - Details in JSP 360 and 2000 Series RAs |
| | | 3016(3): Withdrawn – Details in RA 3500 Series |
| | | 3016(4): Withdrawn - To be covered in unit orders where required |
| RA 3017 | Aerodrome Vehicles | 3017(1): Replaced by RA 3267 - Aerodrome Vehicle Marking and Lighting Requirements |
| | | 3017(2): Replaced by RA 3267 - Aerodrome Vehicle Marking and Lighting Requirements |
| RA 3018 | Aerodrome Control | 3018(1): Replaced by RA 3261 - Aerodrome Service |
| | | 3018(2): Replaced by RA 3261 - Aerodrome Service |
| | | 3018(3): Replaced by RA 3261 - Aerodrome Service |

| RA NUMBER | RA DESCRIPTION | SUB RA |
|-----------|--|---|
| | | 3018(4): Replaced by RA 3261 - Aerodrome Service 3018(5): Replaced by RA 3261 - Aerodrome Service 3018(6): Replaced by RA 3266 – Aerodrome Maintenance 3018(7): Replaced by RA 3264 – Aerodrome Inspections 3018(8): Replaced by RA 3272 - Continuous Friction Measuring Equipment (CFME) 3018(9): Replaced by RA 3278 - Snow and Ice Operations 3018(10): Replaced by RA 3270 - Bird Control 3018(11): Replaced by RA 3269 - Air Traffic Control (ATC) Pyrotechnics and Firearms 3018(12): Withdrawn - Detail in JSP 360 and 2000 Series RAs 3018(13): Replaced by RA 3271 - Brake Parachute Recovery 3018(14): Replaced by RA 3276 - Truck Runway Control (TRC) |
| RA 3019 | Aerodrome Lighting | 3019(1): Replaced by RA 3265 - Aerodrome Lighting Operating Requirements 3019(2): Replaced by RA 3265 - Aerodrome Lighting Operating Requirements 3019(3): Replaced by RA 3264 - Aerodrome Inspections |
| RA 3020 | NATO Standard Aerodrome Procedures | 3020(1): Withdrawn - Details in STANAG 3297 - NATO Standard Aerodrome and Heliport ATS Procedures |
| RA 3021 | Aircraft Arresting Systems | 3021(1): Replaced by RA 3268 - Air System Arresting Systems 3021(2): Replaced by RA 3268 - Air System Arresting Systems 3021(3): Replaced by RA 3268 - Air System Arresting Systems |
| RA 3023 | Terminal Procedures - General | 3023(1): Withdrawn - Detail now spilt between 2000 Series RA's, new 3000 Series RA's and MMATM for process 3023(2): Withdrawn - Not deemed regulatory material 3023(3): Retained in MMATM 3023(4): Withdrawn - Covered in relevant equipment documentation |
| RA 3024 | Surveillance Directing and Ground Controlled Approach | 3024(1): Withdrawn - Detail in MMATM 3024(2): Withdrawn - Detail in MMATM 3024(3): Replaced by RA 3291 - Precision Approach Radar 3024(4): Replaced by RA 3291 - Precision Approach Radar |

| RA NUMBER | RA DESCRIPTION | SUB RA |
|-----------|---|--|
| | | 3024(5): Replaced by RA 3291(2) - Precision Approach Radar to Civil Pilots |
| RA 3025 | Surveillance Approach Control | 3025(1): Withdrawn - Detail in MMATM |
| | | 3025(2): Withdrawn - Detail in MMATM |
| | | 3025(3): Withdrawn - Detail in MMATM |
| RA 3027 | Lower Airspace Radar Service | 3027(1): Withdrawn - Detail in UK AIP |
| RA 3028 | Air Traffic Control Equipment | 3028(1): Replaced by RA 3206 - Air Traffic Management (ATM) Equipment |
| RA 3030 | Air Traffic Control Radar Units | 3030(1): Withdrawn - Detail now in RA 3222 - Autonomous Radar Units, RA 3223 - Provisions of Air Traffic Service Inside CAS, RA 3202 - ATM Qualifications and RA 3294 - Reporting Hazardous Conditions |
| | | 3030(2): Withdrawn - Detail now in RA 3222 - Autonomous Radar Units, RA 3223 - Provisions of Air Traffic Service Inside CAS, RA 3202 - ATM Qualifications and RA 3294 - Reporting Hazardous Conditions |
| RA 3031 | Area Radar Procedures Above FL195 | 3031(1): Withdrawn - Not deemed regulatory material. Detail to be covered in ATM Force/Unit Orders as required |
| RA 3032 | Area Radar Procedures Below FL195 | 3032(1): Withdrawn - Not deemed regulatory material. Detail to be covered in ATM Force/Unit Orders as required |
| RA 3033 | Special Air Activities | 3033(1): Withdrawn - Detail in 2000 Series RAs |
| | | 3033(2): Withdrawn - Detail in 2000 Series RAs |
| | | 3033(3): Withdrawn - Detail in UK AIP/Mil AIP |
| | | 3033(4): Withdrawn - Detail in ATP-56(B) and AARNIs |
| RA 3034 | Air Surveillance and Control System - General | 3034(1): Withdrawn - detail in RA 3202 - ATM Qualifications, RA 3223 - Provision of Air Traffic Service Inside CAS and RA 3224 - FIS Outside CAS |
| | | 3034(2): Withdrawn - detail in RA 3202 - ATM Qualifications, RA 3223 - Provision of Air Traffic Service Inside CAS and RA 3224 - FIS Outside CAS |
| RA 3035 | Operational Use of Secondary Surveillance Radar (SSR) – General | 3035(1): Withdrawn - Not deemed regulatory material |
| | | 3035(2): Withdrawn - Detail in RA 3227 - Methods of Identification |
| | | 3035(3): Replaced by RA 3226 - SSR |
| | | 3035(4): Replaced by RA 3226 - SSR |
| | | 3035(5): Withdrawn - Details in RA 3227 - Methods of Identification |
| | | 3035(6): Withdrawn - Details in RA 3227 - Methods of Identification |

| RA NUMBER | RA DESCRIPTION | SUB RA |
|-----------|---|--|
| | | 3035(7): Withdrawn - Replaced by RA 3037 - SSR Alone Operations |
| RA 3036 | Emergency Organizations | <p>3036(1): Replaced by RA 3261(2) – Aerodrome Emergency Services</p> <p>3036(2): Replaced by RA 3261(2) – Aerodrome Emergency Services</p> <p>3036(3): Replaced by RA 3261(2) – Aerodrome Emergency Services</p> <p>3036(4): Replaced by RA 3261(2) – Aerodrome Emergency Services</p> <p>3036(5): Withdrawn – not considered regulatory material</p> <p>3036(6): Replaced by RA 3261(2) – Aerodrome Emergency Services</p> <p>3036(7): Replaced by RA 3261(2) – Aerodrome Emergency Services</p> <p>3036(8): Replaced by RA 3261(2) – Aerodrome Emergency Services</p> <p>3036(9): Withdrawn – Not considered regulatory material. Details will be contained in Unit/Local Orders</p> <p>3036(10): Replaced by RA 3311 - Controllers Emergency Actions</p> <p>3036(11): Withdrawn – Not considered regulatory material. Detail contained in JSP 426 Volume 3 Leaflet 02 - MOD Regulations - Airfield Rescue and Fire-fighting Services and Fire and Rescue Service Criteria (Oct 2010)</p> <p>3036(12): Withdrawn – Not considered regulatory material. Detail contained in JSP 426 Volume 3 Leaflet 02 - MOD Regulations - Airfield Rescue and Fire-fighting Services and Fire and Rescue Service Criteria (Oct 2010)</p> |
| RA 3037 | Secondary Surveillance Radar (SSR) Alone Operations | <p>3037(1): Replaced by RA 3241 - Secondary Surveillance Radar (SSR) Alone Operations</p> <p>3037(2): Replaced by RA 3241 - Secondary Surveillance Radar (SSR) Alone Operations</p> <p>3037(3): Replaced by RA 3241 - Secondary Surveillance Radar (SSR) Alone Operations</p> |
| RA 3038 | Diversions | <p>3038(1): Replaced by RA 3313 - Air System Diversions</p> <p>3038(2): Replaced by RA 3313 - Air System Diversions</p> <p>3038(3): Replaced by RA 3313 - Air System Diversions</p> |
| RA 3039 | Overdue Action | 3039(1): Replaced by RA 3312 - Overdue Actions by ATC |
| RA 3040 | Search and Rescue | 3040(1): Withdrawn - Not deemed regulatory material. Detail in ATP-10 for reference and planning purposes and International Aeronautical and Maritime Search and Rescue Manual, 2013 Edition |

| RA NUMBER | RA DESCRIPTION | SUB RA |
|-----------|---|---|
| RA 3041 | Terminal ATC - Controllers' Emergency Actions | 3041(1): Replaced by RA 3311 - Controllers Emergency Actions |
| RA 3042 | Area Radar - Controllers' Emergency Actions | 3042(1): Replaced by RA 3311 - Controllers Emergency Actions |
| RA 3043 | Administration – General | 3043(1): Replaced by RA 3204 - ATM Records |
| | | 3043(2): Replaced by RA 3263 - Aerodrome Classifications |
| | | 3043(3): Withdrawn - Not deemed regulatory material. Process in MMATM |
| RA 3044 | Administration – Civil Aircraft | 3044(1): Withdrawn - Detail in JSP 360 |
| | | 3044(2): Withdrawn - Detail in JSP 360 |
| RA 3045 | Responsibilities of the Radar Analysis Cell and the Low Flying Operations Squadron | 3045(1): Replaced by RA 3205 - Radar Analysis Cell |
| | | 3045(2): Withdrawn - Not deemed regulatory material. Detail in UK Low Flying Handbook |
| RA 3046 | Aeronautical Information | 3046(1): Withdrawn - Detail in UK AIP/Mil AIP |
| | | 3046(2): Withdrawn - Detail in UK AIP/Mil AIP |
| RA 3047 | Air Traffic Services Messages | 3047(1): Withdrawn - Detail in UK AIP |
| RA 3048 | Communications | 3048(1): Withdrawn - Detail in CAP 413 |
| | | 3048(2): Withdrawn - Detail in RA 3206 - ATC Equipment Checks |
| | | 3048(3): Withdrawn - Detail in CAP 413 |
| | | 3048(4): Withdrawn - Detail in CAP 413 |
| | | 3048(5): Withdrawn - Detail in CAP 413 |
| | | 3048(6): Withdrawn - No longer relevant |
| | | 3048(7): Withdrawn - Detail in CAP 413 |
| RA 3101 | Air Traffic Management (ATM) Equipment Organization Exposition (AEOE) | 3101(1): Withdrawn – Incorporated into RA 3100(3) |
| RA 3103 | AAOS Safety and Quality Management Systems | 3103(1): Withdrawn – Incorporated into RA 1027(1) |
| | | 3103(2): Withdrawn – Incorporated into RA 1027(1) |
| RA 3238 | Controlled Airspace Deeming Conventions | 3238(1): Withdrawn – Incorporated into RA 3228(4) |
| RA 3271 | Brake Parachute Recovery | 3271(1): Withdrawn – Incorporated into RA 3261(1): Aerodrome Service |
| RA 3276 | Truck Runway Control | 3276(1): Withdrawn – Incorporated into RA 3279(1) |
| | | 3276(2): Withdrawn – Incorporated into RA 3279(4) |

| RA NUMBER | RA DESCRIPTION | SUB RA |
|-----------|--|---|
| | | 3276(3): Withdrawn – Incorporated into RA 3279(3) |
| RA 3294 | Reporting of Hazardous Flying Conditions | 3294(1): Withdrawn - Not deemed regulatory material |
| | Manual of Aerodrome Design and Safeguarding (MADS) | |

► This RA has been re-formatted for clarity and withdrawn Sub-Regulations have been removed. Other amendments have been made and change marks presented ◀

RA 3049 – Defence Contractor Flying Organization responsibilities for UK Military Air System Operating Locations

Rationale

Accountable Managers (Military Flying) (AM(MF)s) of Defence Contractor Flying Organizations (DCFOs) are accountable for the safe operation of UK Military Registered Air Systems within their Area of Responsibility (AoR), and ensuring that operating Risk to Life (RtL) is As Low As Reasonably Practicable and Tolerable. To support their operations, DCFOs are required to ensure that appropriate facilities and support services are in place at all operating locations where they operate UK Military Registered Air Systems.

Contents

3049(1): Defence Contractor Flying Organizations Operating Location Requirement

3049(2): Defence Contractor Flying Organizations Operating Location Support Services

Regulation 3049(1)

Defence Contractor Flying Organizations Operating Location Requirement

3049(1) AM(MF)s **shall** ensure that UK Military Registered Air Systems operate from appropriate operating locations.

Acceptable Means of Compliance 3049(1)

Defence Contractor Flying Organizations Operating Location Requirement

1. AM(MF)s **should** have processes and procedures in place to ensure that facilities provided at operating locations are appropriate to cover the full scope of the UK Military Registered Air System operations within their AoR.
2. AM(MF)s **should** ensure that embarked operations are only undertaken from vessels holding an appropriate endorsement.

Guidance Material 3049(1)

Defence Contractor Flying Organizations Operating Location Requirement

3. AM(MF)s may wish to consider approvals from other relevant regulatory and / or certification bodies (such as the European Union Aviation Safety Agency) to support their processes (including Risk Management) regarding appropriate operating locations.
4. An appropriate endorsement for UK vessels to carry out embarked operations will be in accordance with (iaw) RA 1395¹.

Regulation 3049(2)

Defence Contractor Flying Organizations Operating Location Support Services

3049(2) AM(MF)s **shall** ensure that adequate Support Services are available for the duration of UK Military Registered Air System operations.

¹ Refer to RA 1395 - Authorization to Permit Embarked Aviation in ►His◀ Majesty's / MOD Ships.

**Acceptable
Means of
Compliance
3049(2)****Defence Contractor Flying Organizations Operating Location
Support Services**

5. Rescue and Firefighting services in support of UK Military Registered Air Systems **should** be provided iaw DSA02 DFRS².
6. AM(MF)s **should** ensure that emergency Medical Services are available to provide an immediate response; the level of response **should** be proportionate to the operating location, flying activity and the Air Systems being operated, and be determined on the basis of an appropriate Risk Assessment.
7. AM(MF)s **should** determine the minimum levels of Air Traffic Management (ATM) Services required to support UK Military Registered Air System operations and **should** ensure that all ATM Services are provided by a Suitably Qualified and Experienced Person.

**Guidance
Material
3049(2)****Defence Contractor Flying Organizations Operating Location
Support Services**

8. Although not specific to DCFOs, AM(MF)s may refer to RA 3263(1)³ for general guidance on Medical Cover; the RA details the differing levels of required medical cover for the range of MOD Aerodromes.

² Refer to Defence Aerodrome Rescue and Fire Fighting Regulations.

³ Refer to RA 3263(1): Aerodrome Classification.

RA 3100 – Air Traffic Management Equipment Approved Organization Scheme

Rationale

Air Traffic Management (ATM)¹ Equipment Organizations that are contracted by the UK MOD to provide and / or install ATM Equipment², and / or provide technical services that support ATM Equipment, are required to be approved in accordance with the ATM Equipment Approved Organization Scheme (AAOS). The AAOS is the Assurance mechanism underpinning the competence of ATM Equipment Organizations and ensures such Organizations comply with the MAA Regulatory Publications (MRP). There is a need to define AAOS processes in order to ensure that in-scope Organizations are able to meet the requirements of the AAOS. This Regulation defines the overarching AAOS processes.

Contents

- 3100(1): Air Traffic Management Equipment Approved Organization Scheme Application and Approval**
- 3100(2): Air Traffic Management Equipment Approved Organization Scheme Approval Changes**
- 3100(3): Air Traffic Management Equipment Organization Exposition**
- 3100(4): Air Traffic Management Equipment Approved Organization Scheme MAA Regulatory Publications Applicability**
- 3100(5): Contracted ► / Subcontracted ◄ Activities**

Regulation 3100(1)

Air Traffic Management Equipment Approved Organization Scheme Application and Approval

3100(1) ATM Equipment Organizations contracted by the UK MOD **shall** be approved under the AAOS, or have a defined and agreed route to being approved under the AAOS.

Acceptable Means of Compliance 3100(1)

Air Traffic Management Equipment Approved Organization Scheme Application and Approval

1. ATM Equipment Organizations **should** satisfy the MAA that it is in the UK MOD and / or National interest to include the Organization in the AAOS.
2. Applications for AAOS approval **should** be:
 - a. Made using MAA AAOS Form 2.
 - b. Supported by an appropriate endorsement of MOD³ / National interest.
 - c. Supported by an ATM Equipment Organization Exposition (AOE)⁴.
3. To maintain AAOS Approval validity, an AAOS Organization **should**:
 - a. Comply with the MRP.
 - b. Ensure that the MAA is granted appropriate access for the purpose of determining initial and continued MRP compliance.
 - c. Ensure that the MAA has approved any changes to the AOE.
 - d. Ensure continued endorsement of MOD / National interest.
4. Revoked or surrendered AAOS Approval Certificates **should** be returned to the MAA.

¹ Activities that are defined as ATM are detailed in MAA02: Military Aviation Authority Master Glossary.

² Not including Airborne ATM Equipment.

³ This is either the MOD Delivery Team or Contracting Organization.

⁴ Refer to RA 3100(3): Air Traffic Management Equipment Organization Exposition.

**Guidance
Material
3100(1)****Air Traffic Management Equipment Approved Organization
Scheme Application and Approval****Application**

5. Organizations seeking new approvals will be aware that the timeline from application to approval is likely to be in the region of 9 to 12 months. Early dialogue with the MAA is encouraged; however, Organizations will note that formal engagement cannot be initiated until appropriate endorsement of MOD / National interest is in place.

6. AAOS applications may be staged; ie initial applications may be made via the MAA AAOS Form 2 once endorsement of MOD / National interest has been received, but with the AOE being submitted at a later date. Further guidance on AAOS applications may be found on the MAA website.

7. ► **When considering AAOS approval in the commercial context it is accepted that where AAOS approval is a requirement in the tender, evidence of route to AAOS accreditation will be considered. Application for AAOS accreditation is therefore to be made upon contract award. Nothing in this para prohibits organizations engaging with AAOS as detailed in para 5.** ◀

Approval

8. When it is considered that there is a case for an ATM Equipment Organization to be included in the AAOS, a detailed appraisal will be carried out by the MAA. The appraisal will seek to establish long-term confidence in the Organization's Safety and management systems, key personnel, and in the company structure relevant to the scope of activity. The ATM Equipment Organization will be audited via documentary and on-site inspections.

9. **Certificate.** When evidence presented by the Organization demonstrates that it satisfies the MAA requirements, an AAOS Approval Certificate will be issued listing:

- a. A unique identifying reference.
- b. The approved Organization, including the operating and trading name if different.
- c. The Organization's principal place-of-business address.
- d. The issue date (and date of revision if required).
- e. The title, name and signature of the MAA approving officer.

10. **Schedule.** An AAOS Schedule defining the scope of activity allowable within the AAOS Approval will be issued listing:

- a. The reference of the AOE which details the approved scope of activity.
- b. Any applicable special limitations.
- c. Name and details of the Accountable Manager (AM).
- d. The title, name and signature of the MAA approving officer.

11. **Validity.** An AAOS Approval will normally be issued for an unlimited duration and will remain valid subject to:

- a. The AAOS Organization remaining in compliance with the MRP.
- b. The MAA being granted access to the AAOS Organization to determine continued compliance with the MRP.
- c. The Approval Certificate not being surrendered, suspended or revoked.
- d. Continued endorsement of MOD / National interest.

12. A list of ATM Equipment Organizations who have been granted approval under the AAOS may be published by the MAA.

**Guidance
Material
3100(1)**

Compliance

13. AAOS Organizations will be subject to compliance Assurance activities conducted by or on behalf of the MAA. Access will be required to personnel, facilities, documents, records, data, procedures and any other materials relevant to compliance.
14. The MAA will withdraw from the AAOS any Organization that no longer meets the requirements.
15. Costs for periodic compliance Assurance activities conducted by or on behalf of MAA will not be recoverable from the MOD.

**Regulation
3100(2)**

Air Traffic Management Equipment Approved Organization Scheme Approval Changes

- 3100(2) Changes to AAOS Approvals **shall** be approved by the MAA.

**Acceptable
Means of
Compliance
3100(2)**

Air Traffic Management Equipment Approved Organization Scheme Approval Changes

16. AAOS Organizations **should**:
- a. Consult with the MAA regarding any issue that might affect their AAOS Approval.
 - b. Notify the MAA of any change:
 - (1) Affecting or likely to affect:
 - (a) The scope of its AAOS Approval Certificate or Schedule.
 - (b) Any elements of its management system that support ATM Equipment activities that are contracted by the UK MOD.
 - (2) To key management personnel who have responsibility for AAOS-related activities.
 - (3) To the AM's operating responsibilities or to their supporting Safety system / Organization that may affect their ability to discharge their key AAOS-related responsibilities.
 - c. Submit a formal application for an uplift⁵ to its AAOS scope of activity at the earliest opportunity.
 - d. Submit a formal notification of any reduction⁶ to its AAOS scope of activity at the earliest opportunity.
 - e. Ensure formal applications and notifications are supported by:
 - (1) Documentation⁷ detailing the proposed changes.
 - (2) An updated AOE.
 - f. Only implement changes to its AAOS Approval upon receipt of formal MAA endorsement.

**Guidance
Material
3100(2)**

Air Traffic Management Equipment Approved Organization Scheme Approval Changes

17. As a minimum, the MAA is to be notified of changes to:
- a. Name and details of the AM.
 - b. Personnel named in the AOE, including the Safety and Quality managers.
 - c. The types / quantities of ATM Equipment being provided and or installed.
 - d. Any technical services that are provided to support ATM Equipment.

⁵ Such as: the addition of a type of ATM Equipment, the addition of an ATM Technical Service or a change in operating location.

⁶ The MAA may be consulted where doubt exists as to whether a scope change is a reduction or otherwise.

⁷ For uplift the documentation required will be analogous to that required to support an initial application for that activity.

**Guidance
Material
3100(2)**

- e. Ownership of the AAOS Organization.
 - f. The AAOS Organization's official name, business name, address and / or mailing address.
18. Application to the MAA for an AAOS Schedule amendment will not constitute approval to operate to the proposed amendment.
19. Following receipt of a scope uplift the MAA will determine continuing compliance with the MRP and amend, if necessary, the AAOS Approval Certificate and / or Schedule.

**Regulation
3100(3)**

Air Traffic Management Equipment Organization Exposition

3100(3) AAOS Organizations **shall** submit an AOE to the MAA.

**Acceptable
Means of
Compliance
3100(3)**

Air Traffic Management Equipment Organization Exposition

20. AAOS Organizations **should** ensure:
- a. Their AOE is up-to-date.
 - b. The MAA is provided with an electronic copy of the current AOE.
 - c. Ensure that all amended AOE's highlight the auditable changes from the previous iteration.
21. The AOE **should** contain, but is not limited to, the following subject headings.
- a. **Organization Management.** As a minimum this **should** contain:
 - (1) A statement signed by the AM confirming that the AOE and any referenced associated documentation define the Organization's compliance and / or continued compliance with the extant MRP. When the AM is not the Chief Executive Officer of the Organization they will have demonstrable delegations from their line management to carry out the AM role.
 - (2) The official name and business name, address and mailing address of the ATM Equipment Organization.
 - (3) The details of the AM and all other key management personnel responsible for AAOS activities, together with their qualifications and experience.
 - (4) An Organizational chart showing associated chains of responsibility.
 - (5) A description of the Organization's scale, including the number of staff associated with the task at each operating site.
 - (6) A list of contracted and subcontracted Organizations together with, where applicable, statements regarding their suitability.
 - (7) The AOE amendment procedure.
 - (8) A statement⁸ of which MRP Regulatory Articles (RAs) are deemed applicable and the method of compliance.
 - b. **Scope of Contracted Activities.** As a minimum this **should** contain a detailed description of the Organization's scope of activities relevant to the approval and explicitly state:
 - (1) All types of ATM Equipment / Technologies being provided and / or installed.
 - (2) All types of ATM technical services that are being provided to support ATM Equipment.

⁸ The AAOS Compliance Matrix as per the MAA website may be used.

**Acceptable
Means of
Compliance
3100(3)**

(3) All locations where in-scope ATM Equipment activities are being conducted.

c. **Safety Management.** As a minimum this **should** contain details of the Organization's Safety Management System (SMS) and associated policies⁹.

d. **Quality Management.** As a minimum this **should** contain details of the Organization's Quality Management System and associated policies⁹.

e. **Maintenance and Operations Procedures.** As a minimum this **should** contain:

(1) Details of the Organization's Maintenance policies, procedures and activities, and how they comply with the requirements of RAs 3104-3108¹⁰.

(2) Details of testing appropriate to the type of equipment and its application, including environmental, ground and flight checking where necessary.

f. **Occurrence Reporting**¹¹. As a minimum this **should** contain:

(1) Occurrence Reporting procedures.

(2) Unsafe Condition Reporting procedures.

(3) Error Management System procedures.

g. **Personnel and Training**¹². As a minimum this **should** contain:

(1) Staff Training Plan.

(2) Training and Competence Records.

(3) Human Factors Training content and periodicity.

22. **Security Management.** As a minimum this **should** contain the security procedures to be applied to ensure that the integrity of the ATM Equipment is not compromised.

**Guidance
Material
3100(3)**

Air Traffic Management Equipment Organization Exposition

23. An AOE is the document, or documents, that contain the material specifying the scope of activity deemed to constitute an AAOS Approval and showing how the AAOS Organization intends to comply with the MRP; any activity not specified will not be covered by the approval.

**Regulation
3100(4)**

Air Traffic Management Equipment Approved Organization Scheme MAA Regulatory Publications Applicability

3100(4) An Organization subject to the AAOS **shall** comply with the MRP.

**Acceptable
Means of
Compliance
3100(4)**

Air Traffic Management Equipment Approved Organization Scheme MAA Regulatory Publications Applicability

24. AAOS Organizations **should** comply with the latest issues of all applicable RAs.

⁹ A signpost / link to existing documentation is acceptable.

¹⁰ Refer to the following RAs: RA 3104 – Air Traffic Management Equipment Approved Organization Scheme Maintenance Records; RA 3105 – Air Traffic Management Equipment Approved Organization Scheme Maintenance Documentation; RA 3106 – Air Traffic Management Equipment Approved Organization Scheme Maintenance Practices; and RA 3108 – Air Traffic Management Equipment Approved Organization Scheme Occurrence Reporting.

¹¹ Refer to RA 3108 – Air Traffic Management Equipment Approved Organization Scheme Occurrence Reporting and RA 1410 – Occurrence Reporting and Management.

¹² ► Refer to RA 1440 – Air Safety Training. ◀

**Guidance
Material
3100(4)**

**Air Traffic Management Equipment Approved Organization
Scheme MAA Regulatory Publications Applicability**

25. MRP compliance will be assessed by the MAA on a Risk-based profile. The Risk-based profile will include such factors as previous regulatory compliance and performance at routine surveillance. Any change to the approved MAA scope of the AAOS Organization will require reassessment of the MRP RA applicability.

**Regulation
3100(5)**

Contracted ► / Subcontracted ◄ Activities

3100(5) AAOS Organizations that subcontract activities in order to meet their contractual obligations to the MOD **shall** be responsible for providing Assurance that the subcontracted Organization is fit for purpose and has appropriate processes in place.

**Acceptable
Means of
Compliance
3100(5)**

Contracted ► / Subcontracted ◄ Activities

26. If an AAOS Organization subcontracts any element of its scope of activities that are specified in its AOE, the AAOS Organization **should** demonstrate:

- a. That it has assured itself of the initial and continued competency of the subcontracted Organization and recorded all decision making processes and assumptions, even if the subcontractor independently holds AAOS accreditation in their own right.
- b. Clear linkages with the subcontracted Organization¹³.

27. An AAOS Organization **should** ensure that processes and procedures are in place to allow the MAA access to the subcontracted Organization, in order to assure the AAOS Organizations' linkages and actions.

**Guidance
Material
3100(5)**

Contracted ► / Subcontracted ◄ Activities

28. For the purposes of this Regulation, the term 'activities' refers to only those specified in the endorsed AOE of the AAOS Organization.

¹³ An example is SMS interfaces.

RA 3102 – Air Traffic Management Equipment Approved Organization Scheme Accountable Manager

Rationale

Air Traffic Management (ATM) Equipment Approved Organization Scheme (AAOS)¹ Organizations are required² to assign a top-level of accountability for the scope of the ATM Equipment activities detailed in their ATM Equipment Organization Exposition (AOE)³. This top-level of accountability is held by the Organization's AAOS Accountable Manager (AM). There is a need to define the roles and responsibilities of an AAOS AM in order to ensure that ►they◄ understands ►their◄ role and can effectively carry out ►their◄ duties. This Regulation defines the roles and responsibilities of an AAOS AM.

Contents

3102(1): Roles and Responsibilities of the Air Traffic Management Equipment Approved Organization Scheme Accountable Manager

Regulation 3102(1)

Roles and Responsibilities of the Air Traffic Management Equipment Approved Organization Scheme Accountable Manager

3102(1) AAOS AMs **shall** hold organizational authority and accountability for all activities conducted within the scope specified in their AAOS Organization's AOE.

Acceptable Means of Compliance 3102(1)

Roles and Responsibilities of the Air Traffic Management Equipment Approved Organization Scheme Accountable Manager

1. AAOS AMs **should**:
 - a. Act as the senior point of contact with the MAA.
 - b. Be responsible for ensuring that compliance with the MAA Regulatory Publications is achieved and maintained.
 - c. Ensure that the AAOS Organization's AOE is maintained and approve all amendments to the AAOS Organization's AOE.
 - d. Actively promote and have direct oversight of an Engaged Air Safety Culture⁴ throughout ►their◄ AAOS-specific Area of Responsibility (AoR).
 - e. Be able to demonstrate that they have assured themselves that all personnel within their AAOS-specific AoR are suitably qualified and experienced to carry out their AAOS-specific roles.
 - f. Ensure that the following are established and maintained:
 - (1) An Air Safety Management System in accordance with (iaw) RA 1200⁵.
 - (2) An effective Quality Management System certified by a national accreditation body, with a scope appropriate to the Organization's ATM Equipment activities.
 - (3) An Occurrence Reporting and Error Management System iaw RA 1410⁶.
2. Where the AAOS AM is not the AAOS Organization's Chief Executive Officer, the appointed AM **should** be able to demonstrate that ►they have:◄
 - a. The freedom and authority to undertake ►their◄ role.

¹ Refer to RA 3100 – Air Traffic Management Equipment Organization Scheme.

² Refer to RA 1027 – ►Air Traffic Management Equipment Organizations - Responsibilities of Contracted Organizations.◄

³ Refer to RA 3100(3): Air Traffic Management Equipment Exposition ►►.

⁴ Refer to the MAA Manual of Air Safety.

⁵ RA 1200 – ►► Air Safety Management.

⁶ RA 1410 – Occurrence Reporting ►and Management.◄

**Acceptable
Means of
Compliance
3102(1)**

b. Defined access to adequate resources to support the ATM Equipment activities that are within the scope specified in the AAOS Organization's AOE.

**Guidance
Material
3102(1)**

**Roles and Responsibilities of the Air Traffic Management
Equipment Approved Organization Scheme Accountable Manager**

3. The first line of defence in Air Safety is the establishment of an Engaged Air Safety Culture as defined in the MAA Manual of Air Safety (MAS). The AAOS AM has a key role to play in establishing and sustaining such a culture, and it is imperative that AMs at all levels lead by example in nurturing and developing an Engaged Air Safety Culture.

RA 3104 – Air Traffic Management Equipment Approved Organization Scheme – Maintenance Records

Rationale

► Air Traffic Management (ATM) Equipment Approved Organization Scheme (AAOS) organizations that support the UK MOD to install and / or provide ATM Equipment, and / or provide technical services that support ATM Equipment, are required to ensure they record and retain an Audit trail of Maintenance activities. Without these processes, there is a Risk that the performance and serviceability of ATM Equipment cannot be accurately established or traced, which may result in unsafe operating conditions. This Regulatory Article is intended to ensure adequate governance of Maintenance procedures, which will safeguard the serviceability and performance of ATM Equipment and provide an aid to engineering investigations. ◀

Contents

3104(1): Recording of Maintenance Work
3104(2): Retention of Maintenance Records

Regulation 3104(1)

Recording of Maintenance Work

3104(1) The ►AAOS◀ organization **shall** record details of all Maintenance work carried out.

Acceptable Means of Compliance 3104(1)

Recording of Maintenance Work

1. Records **should** contain basic details of all serialized components installed to ensure traceability.
2. Maintenance records pertinent to the equipment or services **should** refer to the revision status of the documentation used.
3. ► All Maintenance activity **should** be signed and dated, either physically or electronically. ◀
 - a. ►◀
 - b. ►◀

Guidance Material 3104(1)

Recording of Maintenance Work

4. Properly executed and retained records provide information essential in controlling unscheduled and scheduled Maintenance and troubleshooting to eliminate the need for re-inspection and rework. The prime objective is to have secure and easily retrievable records with comprehensive and legible contents.
5. ► Electronic and hand-written signatures will be considered as legally equivalent. ◀

Regulation 3104(2)

Retention of Maintenance Records

- 3104(2) The ►AAOS◀ organization **shall** retain ►◀ Maintenance records. ►◀
- a. ►◀
 - b. ►◀
 - c. ►◀

**Acceptable
Means of
Compliance
3104(2)**

Retention of Maintenance Records

6. ▶◀
7. ▶ Maintenance records **should** be categorized and retained as follows: ◀
 - a. **Category A.** Documents that contain information that is required to maintain an Audit trail of key events that could affect the ▶performance◀ of the equipment through its life. The documents **should** be retained for the life of the equipment in MOD service plus 5 years.
 - b. **Category B.** Documents that contain information that is required to maintain an Audit trail of key events for the period that the documented work could affect the ▶performance◀ of the equipment. The document **should** be retained until the work it records has been ▶superseded◀ by documented work subsequently carried out.
 - c. **Category C.** These documents contain no ▶performance related◀ information required to maintain an Audit trail, but may be required for later reference. These documents **should** be retained for a minimum of 12 months and then at the discretion of the ▶designated MOD authority.◀
 - d. **Category D.** Retain at the discretion of the designated MOD authority.
8. ▶ The method used to record Maintenance work **should** ensure that the record will be stored safely, securely and be accessible throughout the required retention period.
9. If any Maintenance records are lost, destroyed or otherwise incomplete or unavailable, the designated MOD authority **should** be informed.
10. When an AAOS organization terminates its operation, all retained Maintenance records **should** be returned to the MOD.◀

**Guidance
Material
3104(2)**

Retention of Maintenance Records

11. ▶◀
12. Reconstruction of lost or destroyed records can be ▶completed◀ by reference to other records which reflect the time in service, research of records maintained by Repair facilities and reference to records maintained by individual technicians (eg training records), etc. ▶Once finished◀ and the record is still incomplete, the ▶AAOS organization◀ may make a statement in the new record describing the loss and establishing ▶a◀ best estimate of the time in service.
13. ▶MAM-P¹ and MAM-D² contain guidance that may be applicable to the retention of Maintenance records.◀

¹ ▶ Refer to the Manual of Maintenance Airworthiness – Process (MAM-P).

² Refer to the Manual of Maintenance Airworthiness – Documentation (MAM-D).◀

► This RA has been substantially re-written; for clarity no change marks are presented – please read the RA in its entirety ◀

RA 3105 – Air Traffic Management Equipment Approved Organization Scheme – Technical Information and Maintenance Documentation

Rationale

Air Traffic Management (ATM) Equipment Approved Organization Scheme (AAOS) organizations that support the UK MOD to install and / or provide ATM Equipment, and / or provide technical services that support ATM Equipment, are required to use approved and accurate Technical Information (TI). If TI is not correct, there is a Risk that incorrect Maintenance procedures will be carried out potentially leading to unsafe operating conditions and ATM equipment failure. This Regulatory Article sets out the requirement to utilize the correct TI to ensure that ATM equipment is maintained correctly.

Contents

3105(1): Approved, Current and Applicable Technical Information
3105(2): Withdrawn – Incorporated into RA 3105(1)
3105(3): Withdrawn – Incorporated into RA 3105(7)
3105(4): Withdrawn – Incorporated into RA 3105(8)
3105(5): Withdrawn – Incorporated into RA 3105(1)
3105(6): Withdrawn – Incorporated into RA 3105(1)
3105(7): Amendments to Technical Information
3105(8): Maintenance Documentation

Regulation 3105(1)

Approved, Current and Applicable Technical Information

3105(1) The AAOS organization **shall** use approved, current and applicable TI when performing Maintenance, including Modifications and Repairs.

Acceptable Means of Compliance 3105(1)

Approved, Current and Applicable Technical Information

1. The AAOS organization **should** establish procedures to ensure that:
 - a. Approved, current and applicable TI, relevant to the scope of activity, is used.
 - b. Any errors, conflicts, omissions or obscurities that are discovered with TI are reported to the TI owner in a timely manner, with a record of the communication kept until the matter is resolved.

Guidance Material 3105(1)

Approved, Current and Applicable Technical Information

2. It is recommended that TI and Maintenance documentation is immediately available when Maintenance activity on ATM Equipment is being carried out, and sufficiently accessible in relation to the size of the work programme.
3. The MAM-P¹ and MAM-D² contain guidance and reference to examples of appropriate TI.

Regulation 3105(2)

Requirement to Inform Maintenance Documentation Author of Errors

3105(2) Withdrawn – Incorporated into RA 3105(1).

¹ Refer to the Manual of Maintenance Airworthiness – Process (MAM-P).

² Refer to the Manual of Maintenance Airworthiness – Documentation (MAM-D).

**Acceptable
Means of
Compliance
3105(2)**

**Requirement to Inform Maintenance Documentation
Author of Errors**

4. Withdrawn – Incorporated into RA 3105(1).

**Guidance
Material
3105(2)**

**Requirement to Inform Maintenance Documentation
Author of Errors**

5. Withdrawn – Incorporated into RA 3105(1).

**Regulation
3105(3)**

Modification of Maintenance Documentation

3105(3) Withdrawn – Incorporated into RA 3105(7).

**Acceptable
Means of
Compliance
3105(3)**

Modification of Maintenance Documentation

6. Withdrawn – Incorporated into RA 3105(7).

**Guidance
Material
3105(3)**

Modification of Maintenance Documentation

7. Withdrawn – Incorporated into RA 3105(7).

**Regulation
3105(4)**

Common Work Card or Work Sheet

3105(4) Withdrawn – Incorporated into RA 3105(8).

**Acceptable
Means of
Compliance
3105(4)**

Common Work Card or Work Sheet

8. Withdrawn – Incorporated into RA 3105(8).

**Guidance
Material
3105(4)**

Common Work Card or Work Sheet

9. Withdrawn – Incorporated into RA 3105(8).

**Regulation
3105(5)**

Availability of Maintenance Documentation

3105(5) Withdrawn – Incorporated into RA 3105(1).

**Acceptable
Means of
Compliance
3105(5)**

Availability of Maintenance Documentation

10. Withdrawn – Incorporated into RA 3105(1).

**Guidance
Material
3105(5)**

Availability of Maintenance Documentation

11. Withdrawn – Incorporated into RA 3105(1).

**Regulation
3105(6)**

Maintaining the Accuracy of Maintenance Documentation

3105(6) Withdrawn – Incorporated into RA 3501(1).

**Acceptable
Means of
Compliance
3105(6)**

Maintaining the Accuracy of Maintenance Documentation

12. Withdrawn – Incorporated into RA 3501(1).

**Guidance
Material
3105(6)**

Maintaining the Accuracy of Maintenance Documentation

13. Withdrawn – Incorporated into RA 3501(1).

**Regulation
3105(7)**

Amendments to Technical Information

- 3105(7) An AAOS Organization **shall** ensure that amendments to TI results in equivalent or improved Maintenance procedures.

**Acceptable
Means of
Compliance
3105(7)**

Amendments to Technical Information

14. Where an amendment to TI leads to an amendment to Maintenance procedures, the AAOS organization **should** ensure that ATM Equipment performance is not less safe as a result.
15. The AAOS organization **should** inform the Delivery Team or designated MOD authority of changes to TI that may affect the performance of ATM Equipment.
16. The AAOS Organization **should** establish a process for:
- Raising, tracking and recording requests for amendments to TI, and the response from the TI owner.
 - Receiving and responding to amendments to TI that are initiated externally.
 - Clearly identifying and promulgating amendments to TI.

**Guidance
Material
3105(7)**

Amendments to Technical Information

17. Nil.

**Regulation
3105(8)**

Maintenance Documentation

- 3105(8) The AAOS organization **shall** provide a common Maintenance documentation³ system to be used throughout all areas of the organization operating within the defined scope of Maintenance activity.

**Acceptable
Means of
Compliance
3105(8)**

Maintenance Documentation

18. The AAOS organization **should** ensure that when Maintenance tasks are carried out, the corresponding TI is accurately transcribed onto the common Maintenance documentation, or that precise reference is made to the Maintenance task(s) contained in such TI.
19. Maintenance documentation, whether paper based or electronic **should** be subject to adequate safeguards against unauthorized alteration and have a suitable means of back-up.
20. Complex Maintenance tasks **should** be transcribed onto Maintenance documentation and subdivided into clear stages to ensure a record of the accomplishment of the complete Maintenance task.
21. The organization **should** establish processes to ensure that all Maintenance

³ Maintenance documentation may refer to, for example, job cards, work cards or worksheets.

**Acceptable
Means of
Compliance
3105(8)**

documentation is completed in a correct and consistent manner.

22. The Maintenance documentation **should** differentiate and specify, when relevant, disassembly, accomplishment of task, reassembly and testing.

**Guidance
Material
3105(8)****Maintenance Documentation**

23. In the case of a lengthy Maintenance task involving a succession of personnel to complete such task, it may be necessary to use supplementary work cards or worksheets to indicate what was actually accomplished by each individual person.

► This RA has been substantially re-written; for clarity no change marks are presented – please read the RA in its entirety ◀

RA 3106 - Air Traffic Management Equipment Approved Organization Scheme – Maintenance Practices

Rationale

Air Traffic Management (ATM) Equipment Approved Organization Scheme (AAOS) organizations that support the UK MOD to install and / or provide ATM Equipment, and / or provide technical services that support ATM Equipment, are required to demonstrate the use of defined procedures, practices and processes which are completed under adequate supervision and are all essential elements of a Maintenance management system. If approved Maintenance practices are not used, there is a Risk that ATM equipment will not be maintained correctly or safely, potentially leading to unsafe operating conditions and equipment failure. This Regulatory Article sets out the requirement for approved Maintenance practices to be used to ensure consistent and high levels of support to ATM Equipment.

Contents

3106(1): Air Traffic Management Equipment Approved Organization Scheme Maintenance Practices

Regulation 3106(1)

Air Traffic Management Equipment Approved Organization Scheme Maintenance Practices

3106(1) The AAOS organization **shall** follow approved procedures and practices for all aspects of Maintenance activity, ensuring compliance with the MAA Regulatory Publications.

Acceptable Means of Compliance 3106(1)

Air Traffic Management Equipment Approved Organization Scheme Maintenance Practices

1. The AAOS organization **should**, as a minimum, ensure that:
 - a. Maintenance activity reflects ongoing best practice within the organization and that all procedures, and changes to procedures, are verified and validated before use.
 - b. All Maintenance procedures governing technical activity are designed and presented in accordance with (iaw) good Human Factors principles.
 - c. All Safety related ATM facilities are assured through organizational Maintenance practices iaw the Quality Management System and Safety Management System.
 - d. Methods are in place to detect and rectify Maintenance errors, or deviations from approved procedures, that could result in a failure, malfunction, or Fault, endangering the safe operation of the ATM Equipment.
 - e. Every Maintenance task or group of tasks is signed for by the individual who completed the task or group of tasks in order to prevent omissions.
 - f. There is a test equipment policy which details the provision, control, calibration and review of all test equipment.
 - g. Equipment and system Configuration Control, including build state, modular serial number and Modification status, is in place.
 - h. A Modification control, authorization and approval process is in place for all ATM equipment.
2. Preventative Maintenance activity **should** include and cover all ATM Equipment.

**Guidance
Material
3106(1)**

**Air Traffic Management Equipment Approved Organization
Scheme Maintenance Practices**

3. By signing for a task, the individual is stating that they have completed or supervised the Maintenance / servicing task iaw applicable orders, leaflets and instructions and that they have correctly recorded the serviceability state of the ATM equipment.

RA 3107 – Air Traffic Management Equipment Approved Organization Scheme – Equipment, Tools and Material

Rationale

► Air Traffic Management (ATM) Equipment Approved Organization Scheme (AAOS) organizations that support the UK MOD to provide and / or install ATM Equipment, and / or provide technical services that support ATM Equipment, are required to ensure that Maintenance equipment, tools and material are approved for use and controlled correctly. If Maintenance equipment, tools and material are not used and controlled correctly, there is a Risk that ATM Equipment will not be maintained correctly or safely, potentially leading to unsafe operating conditions and ATM Equipment failure. This Regulatory Article sets out the requirement for Maintenance equipment, tools and material to be approved, used and controlled, to ensure consistent and high levels of support to ATM Equipment. ◀

Contents

3107(1): Equipment, Tools and Material

3107(2): Control of Equipment, Tools and Material

Regulation 3107(1)

Equipment, Tools and Material

3107(1) The ► AAOS ◀ organization **shall** have available and use the necessary equipment, tools and material to perform ► its intended and ◀ approved scope of work.

Acceptable Means of Compliance 3107(1)

Equipment, Tools and Material

1. ► The AAOS organization **should** ensure that only approved equipment, tools and material¹ are used, unless the use of alternative equipment, tools and material is agreed by the designated MOD Authority, via approved procedures. ◀
2. The ► AAOS ◀ organization **should** be able to show that all tools, ► ◀ equipment ► and material ◀, as specified in the Maintenance documentation relevant to the scope of the Approval, can be made available when needed.
3. ► ◀
4. Where ► ◀ Government Furnished Equipment (GFE) is ► used, in accordance with (iaw) with the relevant contract, it **should** be maintained iaw RA 3107(2). ◀

Guidance Material 3107(1)

Equipment, Tools and Material

5. Nil.

Regulation 3107(2)

Control of Equipment, Tools and Material

3107(2) The ► AAOS ◀ organization **shall** ensure that all tools, equipment and ► material ◀, are controlled ► ◀ to ensure serviceability and accuracy. ► ◀

Acceptable Means of Compliance 3107(2)

Control of Equipment, Tools and Material

6. ► All equipment, tools and material **should** be:
 - a. Uniquely identified and controlled to ensure full Accountability and traceability.
 - b. Inspected on a regular basis and, where necessary, serviced and calibrated iaw the equipment manufacturer's instructions, or an officially

¹ ► Including, but not limited to, hand tools, Precision Termination Tooling (PTT) and Test and Measuring Equipment (TME). ◀

**Acceptable
Means of
Compliance
3107(2)**

recognized standard, as appropriate.

c. Clearly labelled to indicate:

- (1) That they are within the applicable inspection, servicing, or calibration interval.
- (2) When the next inspection, service or calibration is due.
- (3) If the item is Unserviceable.◀

7. A register **should** be maintained for all ▶◀ equipment, ▶ tools and material, that require to be controlled in terms of servicing and calibration including, where applicable,◀ a record of calibrations and ▶ the◀ standards used.

8. ▶◀

**Guidance
Material
3107(2)****Control of Equipment, Tools and Material**

9. ▶ An◀ 'officially recognized standard' ▶ refers to◀ those standards established ▶ by the manufacturer◀ or published by an official body, which are widely recognized by the aviation / ATM sector as constituting ▶ best◀ practice. ▶◀

10. ▶ The MAM-P² and MAM-D³ contain further guidance.◀

² ▶ Refer to the Manual of Maintenance Airworthiness – Process (MAM-P).

³ Refer to the Manual of Maintenance Airworthiness – Documentation (MAM-D).◀

RA 3108 – Air Traffic Management Equipment Approved Organization Scheme – Occurrence Reporting

Rationale

► *Air Traffic Management (ATM) Approved Organization Scheme (AAOS) organizations that support the UK MOD to provide and / or install ATM Equipment, and / or provide technical services that support ATM Equipment, are required to ensure that Occurrences, including near misses and findings in the condition of ATM Equipment or delivery of services, are reported. If Occurrences are not reported, there is a Risk that ATM Equipment may be used in an unsafe condition, and it will prevent timely trend analysis. This Regulatory Article sets out the requirement for Occurrence reporting, to ensure adequate Occurrence reporting systems are in place.* ◀

Contents

3108(1): Unsafe Condition Reporting
3108(2): Internal Occurrence Reporting
3108(3): MOD Sponsored Reporting Action

Regulation 3108(1)

Unsafe Condition Reporting

3108(1) The ► **AAOS** ◀ organization **shall** report to ► **the relevant departments of the** ◀ MOD any ► **unsafe** ◀ condition of ► **ATM** ◀ Equipment ► ◀ that has resulted, or may result, in a ► ◀ Hazard to Air Safety.

Acceptable Means of Compliance 3108(1)

Unsafe Condition Reporting

- The AAOS organization **should** maintain documented procedures for recording, reporting and informing the MOD of ATM Equipment unsafe conditions. These procedures **should** be formally agreed with the designated MOD authority.
- All Accidents, Incidents, near-misses and failures of Safety controls **should** be reported and investigated to a suitable depth in order that Causes are understood, lessons identified, promulgated and implemented and trends analysis enabled. ◀

Guidance Material 3108(1)

Unsafe Condition Reporting

- Timely and accurate Occurrence reporting is required across Defence Aviation to notify all relevant agencies of actual and potential Hazards, initiate further investigation where appropriate to identify root Causes, and enable data capture and analysis. ◀

Regulation 3108(2)

Internal Occurrence Reporting

3108(2) The ► **AAOS** ◀ organization **shall** establish an internal Occurrence reporting system to enable the collection and evaluation of ► **all Occurrence** ◀ reports. ► ◀

Acceptable Means of Compliance 3108(2)

Internal Occurrence Reporting

- The ► **internal Occurrence reporting** ◀ system **should** be defined in the ► **AAOS organization Exposition**. ◀
- The ► **internal Occurrence reporting** ◀ system **should** identify adverse trends, investigation processes, corrective actions taken, or to be taken, by the organization to address deficiencies and include evaluation of all known relevant information relating to Occurrences and a method to circulate the information as necessary.
- An organization **should** establish a ► **pro-active and engaged Safety culture** which encourages Occurrence reporting, and recognizes, at all levels of Occurrence reporting, investigation and management, that error is a normal part of human

**Acceptable
Means of
Compliance
3108(2)**

activity. ◀

7. The internal reporting system **should** ensure that actions are taken internally to address Safety Hazards.
8. The system **should** provide feedback to report originators, both on an individual and more general basis, ▶ ◀ to ensure their continued support for the scheme.

**Guidance
Material
3108(2)**

Internal Occurrence Reporting

9. The aim of Occurrence reporting is to identify the factors contributing to Incidents and to make the system resistant to similar errors. An Occurrence reporting system ▶ **will** ◀ enable and encourage free and frank reporting of any Safety related Occurrence (including potential Occurrences).
10. ▶ ◀

**Regulation
3108(3)**

MOD Sponsored Reporting Action

- 3108(3) The ▶ **AAOS** ◀ organization **shall** ▶ **respond to MOD sponsored reporting action** ◀ in a form and manner established by the MAA ▶ ◀.

**Acceptable
Means of
Compliance
3108(3)**

MOD Sponsored Reporting Action

11. Extant MOD procedures for Occurrence reporting **should** be used, ▶ **including the use of the Air Safety Information Management System (ASIMS)**. ◀ Details are published in:
 - a. ▶ **RA 1410**¹.
 - b. **MAM-P² Chapters 9.1 – Fault reporting.**
 - c. **MAM-P Chapter 11.1 – Defence Air Environment Quality Policy.**
 - d. **Air Publication (AP) 600³ Chapter 2.1.4 – Status Reporting – Air Traffic Management Equipment.**
12. When responding to MOD sponsored reporting action, the AAOS organization **should** ensure that all pertinent information about the condition of the ATM Equipment and evaluation results are included. ◀

**Guidance
Material
3108(3)**

MOD Sponsored Reporting Action

13. ▶ **If AAOS organizations or Subcontracted organizations do not have direct access to ASIMS, a manual version** ◀ of the Defence Air Safety Occurrence Report (DASOR) ▶ **may be used and submitted** ◀ through the service organization ▶ **with which they are** ◀ Contracted ▶ ◀.

¹ ▶ Refer to RA 1410 – Occurrence Reporting and Management.

² Refer to the Manual of Maintenance Airworthiness – Process (MAM-P).

³ Refer to AP600 - RAF Information & CIS Policy. ◀

► This RA has been substantially rewritten; for clarity no charge marks are presented – please read RA in its entirety ◀

RA 3120 – Air Traffic Management Equipment Standards

Rationale

To ensure the safe provision of Air Traffic Services all new and modified Air Traffic Management (ATM) Equipment will be designed to meet a minimum standard. If ATM Equipment does not meet an appropriate minimum standard it can lead to the delivery of unsafe operations, increasing the Risk to Life in an Aviation Duty Holder (ADH) / Accountable Manager (Military Flying) (AM(MF)) operation. This Regulatory Article (RA) requires that new and modified ATM Equipment meets the minimum standard demonstrating that it is, or will be, safe to operate and operated safely for its application and operating environment.

Contents

3120(1): Air Traffic Management Equipment Standards

Regulation 3120(1)

Air Traffic Management Equipment Standards

3120(1) The Delivery Team Leader (DTL) **shall** ensure that all new and modified ATM Equipment¹ meets the required standards.

Acceptable Means of Compliance 3120(1)

Air Traffic Management Equipment Standards

1. The DTL **should** ensure that new or modified ATM Equipment¹ is compliant with Def Stan 00-972² and present supporting evidence to the MAA and Release To Service Authority.
2. Legacy equipment³ is exempt from compliance with Def Stan 00-972 until it reaches its Out of Service Date (OSD). At this point the DTL **should** replace the equipment ensuring compliance with Def Stan 00-972.
3. If the OSD is extended, a gap analysis against Def Stan 00-972 **should** be conducted by the Delivery Team (DT)⁴ to demonstrate the level of compliance against Def Stan 00-972⁵. If full compliance cannot be demonstrated, the DTL **should**:
 - a. Modify the ATM Equipment to address areas of non-compliance.
 - b. Raise Air Traffic Management – Assurance Review Item (ATM-ARI) action if the areas of non-compliance cannot be addressed.
4. When a modification to legacy ATM Equipment is required and not associated with OSD, it **should** be assured through the RiSP.
5. If, at any point, an issue arises in relation to Safety, performance or Regulatory requirements, an ATM-ARI⁶ form **should** be raised.

Guidance Material 3120(1)

Air Traffic Management Equipment Standards

6. Where more than one Safety principle or target could be applied due to an accumulation of services or where a common mode failure is introduced, the most stringent standard / target will be used.

¹ Refer to RA 3134(1): Air Traffic Management Equipment Release into Service Process – paras 4, 5 and 6.

² Refer to Def Stan 00-972 - Military Air Traffic Services Equipment Safety and Performance Standards (Aerodrome, Terminal and Naval Air Traffic Services).

³ Legacy equipment is equipment that was contracted for prior to the release of Def Stan 00-972, Issue 1 dated 21 May 2012.

⁴ Any reference to a DT within this RA also includes any organization responsible for delivering ATM Equipment, whether or not they are a Defence Equipment & Support (DE&S) DT; this includes Platform Authorities and other project teams with a similar remit.

⁵ If the gap analysis concludes full compliance, the ATM Equipment is to complete the Release into Service Process (RiSP) and will not retain its legacy status.

⁶ Rejected ATM-ARIs may require an Alternative Acceptable Means of Compliance, Waiver or Exemption submission in accordance with MAA03: MAA Regulatory Processes.

**Guidance
Material
3120(1)**

7. When equipment is partially modified, then the MAA Audit will only focus on the modified elements and the remaining legacy equipment⁷ will not be assured by the MAA.
8. Def Stan 00-972 has made the maximum use of civilian Regulations and standards, of which not all are legally binding on military activity. If other standards / Regulations are used in addition to the Def Stan 00-972 that are not legally binding in their own right, the precedence that must be applied is as follows:
- a. Def Stan 00-972.
 - b. North Atlantic Treaty Organization (NATO) Standardization Agreements (STANAG)s.
 - c. International Regulations (International Civil Aviation Organization Standards and Recommended Practices).
 - d. UK Regulations (Civil Aviation Authority Publications).
 - e. European Standards and Regulations (EU Regulations and European Safety Regulatory Requirements).
 - f. Recognized Good Practice⁸.
9. In circumstances where any standard contained in paragraphs c to e are directly binding to the military activity in question, they will be given precedence to paragraphs a and b in the event that there are contradictions between the relevant documents. If there remains any doubt as to the precedent to be applied, early consultation with the MAA is advised.
10. The ATM-ARI is a formal means of communicating an issue, chronologically recording Regulated Community and MAA positions, until a mutually acceptable position is reached. Further information is available in the Manual of Military Air Traffic Management Equipment Assurance (MMATMEA)⁹.
11. Early development of a Release into Service Strategy (RiSS)¹⁰ and engagement with the MAA is recommended where new equipment or Modifications to existing equipment is being considered.

⁷ Continued operation of legacy ATM Equipment is to be supported by a robust Safety argument signed off by the legally accountable person who has accepted the Risk is As Low As Reasonably Practicable (ALARP) and Tolerable.

⁸ Recognized Good Practice is the generic term for those standards for controlling Risk which have been judged and recognized by the Health and Safety Executive (HSE) as satisfying the law when applied to a particular relevant case in an appropriate manner.

⁹ Refers to the MMATMEA, chapter 5.

¹⁰ Refer to RA 3134 – Air Traffic Management Equipment Release into Service Process.

RA 3130 – Air Traffic Management Equipment Safety Management

Rationale

There is a requirement to demonstrate that design solutions for new Air Traffic Management (ATM) Equipment or modifications to in-service ATM Equipment are procured using recognised safety practices and processes, and that ATM Equipment is safe to operate and is being operated safely.

Contents

- 3130(1): Project/Delivery Team Leader Responsibilities**
- 3130(2): User/Operator Responsibilities**
- 3130(3): Legislation Compliance**
- 3130(4): Configuration Management**
- 3130(5): Safety Documentation Retention**
- 3130(6): Independent Safety Auditor**
- 3130(7): Air Traffic Management Equipment Risk Classification**
- 3130(8): Air Traffic Management Equipment Risk Management**

Regulation 3130(1)

Project/Delivery Team Leader Responsibilities

3130(1) The Project/Delivery Team Leader (PTL/DTL) **shall** be responsible for delivering safe systems, services¹ and equipment.

Acceptable Means of Compliance 3130(1)

Project/Delivery Team Leader Responsibilities

1. The PTL/DTL **should** ensure throughout the life of the ATM systems, services, and equipment that:
 - a. ATM Equipment is supported by an ATM Equipment Safety Case (SC) iaw RA 3132.
 - (1) Safety targets and requirements are set and communicated in the ATM Equipment SC Part 1, System Requirements Documents (SRD) or other relevant safety documentation.
 - b. Aviation Duty Holders (DH) are supported effectively in controlling risks to ensure that they are reduced ►so that they are As Low As Reasonably Practicable (ALARP) (see RA 1210) and Tolerable◀ through life.
 - c. Appropriate through-life safety management arrangements are established for the ATM Equipment, including Safety Management Systems and plans (see RA 1200 and the Manual of Air safety).
 - d. Maintenance and training procedures are detailed in technical documentation to ensure safe practises are adhered to.
 - e. Support documentation and training documentation are maintained and their configuration controlled.
 - f. Arrangements are in place for monitoring and recording safety performance, and regular reviews are carried out.
2. The PTL/DTL **should** ensure:
 - a. Users (operators and/or maintainers) are provided with ATM Equipment user instructions, training, and maintenance procedures.
 - b. All relevant documentation is subject to configuration control.

¹ In this regulation services refers to equipment engineering services, not an Air Traffic Service as defined in MAA 02.

**Acceptable
Means of
Compliance
3130(1)**

- c. Users (operators and/or maintainers) understand the safety implications of any changes, such as PT/DT equipment modifications or operator procedural changes.
- d. If users (operators and/or maintainers) are required to operate the systems outside of the defined safe maintenance and performance envelope due to operational reasons:
 - (1) Risk assessments and impact statements **should** be written.
 - (2) ,Permission **should** be sought from the local commander and/or Aviation DH as appropriate.
 - (3) The DTL/PTL **should** be informed.

**Guidance
Material
3130(1)**

Project/Delivery Team Leader Responsibilities

- 3. The Project Oriented Safety Management System (POSMS) describes processes and procedures which are designed to assist with the identification and management of the safety risks of equipment and services throughout the acquisition process. The scope of POSMS is limited to acquisition projects for equipment and services

**Regulation
3130(2)**

User/Operator Responsibilities

- 3130(2) The Users (operators and/or maintainers) **shall** operate and maintain ATM Equipment in accordance with the ATM Equipment SC, user instructions and maintenance procedures.

**Acceptable
Means of
Compliance
3130(2)**

User/Operator Responsibilities

- 4. Through formalized agreements with the PT/DT where appropriate, users (operators and/or maintainers) **should**:
 - a. Confirm user instructions and maintenance procedures have been maintained and configuration controlled according to PT/DT changes.
 - b. Confirm ATM Equipments are being maintained and used in accordance with PT/DT procedures and safe performance envelopes.
 - c. Immediately report to the PT/DT, via the relevant FLC organization (e.g. RAF Engineering Role Office) concerns identified by users (operators and/or maintainers). Examples of concerns include unexpected performance or failures.
 - d. Report to the PT/DT all decisions taken to operate ATM Equipment and support outside defined performance and maintenance envelopes.

**Guidance
Material
3130(2)**

User/Operator Responsibilities

- 5. Nil.

**Regulation
3130(3)**

Legislation Compliance

- 3130(3) The PTL/DTL **shall** ensure that a compliance assessment is undertaken for the ATM Equipment against all relevant legislation as appropriate during the Equipment's life cycle .

**Acceptable
Means of
Compliance
3130(3)**

Legislation Compliance

6. Compliance **should** be assessed in three stages as follows:
- a. **Prior to contract award.** An initial compliance assessment **should** be made by the PT/DT to support Part 1 of the ATM Equipment SC. This broad assessment **should** identify the key items of legislation that could be applicable and any areas of potential non-compliance.
 - b. **During development and manufacture of equipment.** The PTL/DTL **should** ensure that a detailed compliance assessment is undertaken and that it includes all of the legislation for the ATM Equipment, managed through to compliance or to a justified position of non-compliance. The compliance assessment is an on-going process until the ATM Equipment is ready to be released into service in order that emergent legislation may be managed.
 - c. **Before Release into Service Process.** The PTL/DTL **should** ensure that the compliance assessment is completed in order to provide evidence into the Release into Service Process through the ATM Equipment SC.

**Guidance
Material
3130(3)**

Legislation Compliance

7. The purpose of the compliance assessment is to:
- a. Record all legislation deemed applicable to the ATM Equipment.
 - b. Apply scrutiny to its design features to ensure compliance.
 - c. Ensure that the correct process is followed where compliance cannot be achieved for operational reasons.
8. The PT/DT need to be aware that compliance status could change throughout the development and manufacture of the ATM Equipment and that justifiable non-compliances may become apparent up to release into service.
9. The detailed compliance assessment is usually provided by the supplier.

**Regulation
3130(4)**

Configuration Management

- 3130(4) The PTL/DTL **shall** be responsible for Configuration Management (CM) throughout the life of the ATM Equipment.

**Acceptable
Means of
Compliance
3130(4)**

Configuration Management

10. The PTL/DTL **should** develop and implement a Configuration Management Plan (CMP). The CMP **should** define how CM is to be carried out and detail the processes used to ensure that the ATM Equipment's functional and physical characteristics conform to the requirements throughout the life cycle of the ATM Equipment. As a minimum, a CMP **should**:
- a. Be documented.
 - b. Show the configuration of an item at any time in its life cycle.
 - c. Provide a means for managing modifications.
 - d. Involve the principle CM activities of planning, documenting, controlling, accounting for and auditing the item's configuration.
11. JSP 886 provides details regarding the contents and structure of a typical CMP, as a minimum, the CMP **should** address:
- (1) Purpose, scope and programme.
 - (2) Organization structures, committees and responsibilities.
 - (3) Configuration change management procedures.
 - (4) Change control of the CMP.
 - (5) Relationships with other plans.

**Acceptable
Means of
Compliance
3130(4)**

- (6) Configuration audit.
12. The PTL/DTL **should**:
- a. Review and take decisions on changes to ATM Equipment specification or design which could significantly affect project safety, performance, cost, timescales or delivery.
 - b. Agree project/ATM Equipment modification policy and the associated timescales.
 - c. Document all configuration changes and maintain an auditable trail of all proposals, reviews and decisions.
 - d. Ensure that the impact of individual modifications is assessed across the whole ATM Equipment range and that an annual review process maintains the agreed progress of embodiment.
 - e. Ensure that a focal point for the maintenance of CM is appointed and a statement included in staff terms of reference identifying individual authorities and responsibilities for CM within a PT/DT.
 - f. Ensure that, where items of ATM Equipment are shared across multiple PTs/DTs, CM is strictly maintained and duplicated activities are avoided.
 - g. Ensure that all modification procedures conform to the guidelines and procedures described in the MRP, single-Service APs and any subordinate Business Procedures.
13. For Service Modifications, the PT/DT must ensure that all relevant parties are made aware of the amendment and relevant documentation (incl. maintenance) is updated accordingly.

**Guidance
Material
3130(4)**

Configuration Management

14. Configuration Management will need to be applied by the PT/DT in order to maintain effective control of the approved configuration. Configuration Management should also prevent unauthorized changes being made without the valid authorization via PT/DT Change Management Process. Change Management will need to be applied in order:
- a. Ensure that change proposals are processed in a timely manner and are justified in terms of:
 - (1) Safety.
 - (2) Performance.
 - (3) Whole-life costs.
 - (4) Support.
 - (5) Project timescale.
 - b. Apply a classification, including:
 - (1) Applicability of change.
 - (2) Possible need for retrospective action.
 - (3) Degree of urgency.
 - c. Evaluate the impact of major deviations and modifications.
 - d. Enable the implementation of authorized changes and make use of configuration status accounting to track progress from concept through to completion.
15. Initial Configuration Control (CC) is vested in the Designer, who provides the Configuration Status Record (CSR). This contains the indexes to master sets of drawings, amendments, modifications, ancillary equipment and Service-supply items. It must be kept up-to-date throughout the life of the ATM Equipment, on behalf of the PT/DT, by the Designer. The CSR provides a baseline for defining the as-fitted and modification state throughout the life of the ATM Equipment.

**Regulation
3130(5)**

Safety Documentation Retention

3130(5) All safety documentation relating to ATM Equipment **shall** be retained for a minimum of 5 years beyond the equipment's out of Service date.

**Acceptable
Means of
Compliance
3130(5)**

Safety Documentation Retention

15. Documentation **should** be clearly marked and securely stored to avoid accidental destruction.

**Guidance
Material
3130(5)**

Safety Documentation Retention

16. Scanned copies of documents are legally allowable under the "best evidence" principle.

17. Electronic storage can be used providing documents are protected to prevent accidental deletion.

**Regulation
3130(6)**

Independent Safety Auditor

3130(6) The PTL/DTL **shall** consider the appointment of an Independent Safety Auditor (ISA) at the outset of a project, in consultation with the Project Safety Panel (PSP).

**Acceptable
Means of
Compliance
3130(6)**

Independent Safety Auditor

18. The PTL/DTL **should** ensure that an auditable trail of the decision regarding the requirement for an ISA exists.

19. The ISA **should**:

a. Undertake the task of audits and other assessment activities to:

(1) Provide assurance that safety activities comply with planned arrangements.

(2) Provide assurance that safety activities are implemented effectively and are suitable to achieve objectives.

(3) Confirm whether related outputs are correct, valid and fit for purpose.

b. Have a well defined role that is documented and clearly understood by all parties.

c. Be independent of the organization being supported and have a good understanding of safety issues related to systems under review.

d. Sit as a full member of the PSP and their role and function **should** be defined in the Management Plan.

20. The ISA's independence **should** not be compromised by involving them in activities such as setting Safety Requirements, tender assessment or providing specific advice on engineering changes.

**Guidance
Material
3130(6)**

Independent Safety Auditor

21. The use of an ISA can enhance a PT/DT's assurance arrangements, by assisting with the maintenance of safety integrity across large and/or high risk projects.

22. The ISA role may include providing assurance by auditing the safety process being followed, or by doing some safety assessment independently to check the primary assessment. The role may change at different points through the life cycle.

**Guidance
Material
3130(6)**

23. The primary role of an ISA is assessment and validation of the ATM Equipment SC work. This is usually carried out through audit of the following:
- The safety management arrangements set out in the Safety Management Plan (SMP) and ATM Equipment SC.
 - The safety activities set out in the contractor's Safety Programme Plan in response to the SMP.

**Regulation
3130(7)**

Air Traffic Management Equipment Risk Classification

- 3130(7) ATM risks involving ATM Equipment **shall** be classified and handled using the ATM Equipment Risk Classification Matrix.

**Acceptable
Means of
Compliance
3130(7)**

Air Traffic Management Equipment Risk Classification

24. This regulation **should** be read in conjunction with RA 1210 - Management of Operating Risk, Risk to Life (RtL) and Def Stan 00-56 Safety Management Requirements for Defence Systems.
25. This regulation **should** be used by PTs/DTs and users (operators and/or maintainers).
26. Annex A of this RA contains the ATM Equipment Risk Severity Classifications definitions (table 1) and Risk Classification Matrix (table 2). The information at Annex A **should** be used for ATM risks² that have an ATM Equipment element, but can also include people, procedure and environment elements, for example in the mitigations. For ATM risks that are unrelated to ATM Equipment RA 1210 **should** be used directly (see RA 3130(8)).
27. The ATM Equipment SC **should** set out and justify the process for making ALARP decisions.
28. Whenever there are changes to an ATM Equipment's design, role, operating environment and/or changes in legislation there **should** be a re-assessment of all risks falling within the scope of the changes.

**Guidance
Material
3130(7)**

Air Traffic Management Equipment Risk Classification

29. EU Eurocontrol Safety Regulatory Requirement 4 (ESARR4) states that the Maximum Tolerability (of ATM direct contribution) to a Severity Class 1 Incident in the European Civil Aviation Conference (ECAC) Region, is 1.55×10^{-8} per flight hour (controlled). It is agreed that this is broadly suitable for use in a Military/Civil Joint and Integrated ATM environment.
30. It is important to note that 'tolerability' does not mean 'acceptability'. It refers to a willingness to live with a risk to secure certain benefits in the confidence that it is being properly controlled. To tolerate a risk means that it is not regarded as insignificant or something that could be ignored, but rather as something that needs to be kept under review and reduced further if possible

Risk Management Process

31. The aim of risk management is to ensure and demonstrate that all foreseeable risks have been identified and reduced ►so that they are ALARP and Tolerable. ◀ It is an iterative process that will continue throughout the life of a system.

The essential steps required to manage Risks successfully can be found in the Guidance Material of RA 1210(2)&(3). All steps to manage risks must involve the PSP.

Risk Classification

32. A qualitative or quantitative approach can be used to determine the appropriate risk classification. Where possible, a quantitative approach must be used when a system poses significant risk.

² An ATM Risk is the risk resulting from a hazard caused by the provision of ATM. It should be considered by the service provider but will be held by the Aviation DH if it is a RtL, otherwise will be held by the PTL/DTL or the user, as appropriate.

**Guidance
Material
3130(7)**

33. Annex A contains specific details for ATM Equipment risk classification. It has both quantitative figures and qualitative descriptions.

34. Whether a qualitative or quantitative approach is used, demonstration that a target has been achieved, or bettered, may not always be practicable. It may be used to indicate the level of performance/integrity expected from the system, and as a baseline against which to argue the ATM Equipment SC.

**Regulation
3130(8)**

Air Traffic Management Equipment Risk Management

3130(8) PTLs/DTLs or users (operators and/or maintainers) **shall** ensure that ATM Equipment hazards are articulated to Aviation DHs in a manner which enables DHs to assess any associated Risk to Life (RtL) appropriately.

**Acceptable
Means of
Compliance
3130(8)**

Air Traffic Management Equipment Risk Management

35. RtL **should** only be owned by Aviation DHs and therefore all factors affecting RtL must be articulated to the relevant Aviation DHs to allow them to consider the RtL appropriately.

36. Aviation DH responsibilities regarding RtL are laid down in RA 1210. Relevant ATM Equipment risks **should** be articulated to Aviation DHs with all the appropriate information and evidence to enable Aviation DHs to comply with RA 1210.

**Guidance
Material
3130(8)**

Air Traffic Management Equipment Risk Management

37. Nil.

ANNEX A
ATM EQUIPMENT RISK CLASSIFICATION

1. ATM Equipment risks must have their severity classified using the information in table 1. The definitions in table 1 provide descriptions of possible outcomes.

Table 1. ATM Equipment Risk Severity Classifications.

| Severity | Definitions ³ |
|-------------------|--|
| Catastrophic 1 | <ul style="list-style-type: none"> -One or more catastrophic accidents. -One or more mid-air collisions. -One or more collisions on the ground between two aircraft. -One or more Controlled Flight Into Terrain. -Total loss of flight control. (No independent source of recovery mechanism, such as surveillance or ATC and/or flight crew procedures can reasonably be expected to prevent the accident(s)). -ATC issues instruction or information which can be expected to cause loss of one or more aircraft (no reasonable and reliable means exists for the aircrew to check the information or mitigate against the hazards). -Continued safe flight or landing prevented. |
| Hazardous 2 | <ul style="list-style-type: none"> -Large reduction in separation (e.g., a separation of less than half the separation minima), without crew or ATC fully controlling the situation or able to recover from the situation. -One or more aircraft deviating from their intended clearance, so that abrupt manoeuvre is required to avoid collision with another aircraft or with terrain (or when an avoidance action would be appropriate). -The ATC separation service provided to aircraft that are airborne or are inside a runway protected area in one or more sectors is suddenly, and for a significant period of time, completely unavailable. -Provision of instructions or information which may result in a critical near mid-air collision or a critical near collision with the ground. Many losses of Acceptable separation possible. |
| Major 3 | <ul style="list-style-type: none"> -Large reduction (e.g., a separation of less than half the separation minima) in separation with crew or ATC controlling the situation and able to recover from the situation. -Minor reduction (e.g., a separation of more than half the separation minima) in separation without crew or ATC fully controlling the situation, hence jeopardising the ability to recover from the situation (without the use of collision or terrain avoidance manoeuvres). -The ATC separation service provided to aircraft that are airborne or are inside a runway protected area in one or more sectors is suddenly, and for a significant period of time, severely degraded or compromised (e.g. contingency measures required or controller workload significantly increased such that the probability of human error is increased). -The ATC separation service provided to aircraft on the ground outside a runway protected area is suddenly, and for a significant period of time, completely unavailable. -Provision of instructions or information which may result in the separation between aircraft or aircraft and the ground being reduced below normal standards. -No ATS action possible to Support aircraft emergency. |
| Minor 4 | <ul style="list-style-type: none"> -Increasing workload of the air traffic controller or aircraft flight crew, or slightly degrading the functional capability of the enabling CNS system. -Minor reduction (e.g., a separation of more than half the separation minima) in separation with crew or ATC controlling the situation and fully able to recover from the situation. -The ATC Separation service provided to aircraft that are airborne or are inside a runway protected area in one or more sectors is suddenly, and for a significant period of time, impaired. -The ATC separation service provided to aircraft on the ground outside a runway protected area is suddenly, and for a significant period of time, severely degraded. -ATS emergency support ability severely degraded. |
| Negligible 5 | <ul style="list-style-type: none"> -No hazardous condition i.e. no immediate direct or indirect impact on the operations. -No effect on ATC separation service provided to aircraft. -Minimal effect on ATC separation service provided to aircraft on the ground outside a runway protected area. -Minimal effect on ATS emergency support ability. |

³ Definitions are taken from a combination of ESARR 4 and CAP 728.

Table 2. ATM Equipment Risk Classification Matrix.

| ATM Probability | | | ATM Severity | | | | |
|-----------------|-----------------------------|---|----------------|---|---|---|---|
| ATM Frequency | ATM Qualitative Description | Probability per controlled flying hour (CFg Hr ⁴) | 1 | 2 | 3 | 4 | 5 |
| | | | ATM Risk Class | | | | |
| Frequent | Likely to occur often | $>2.8 \times 10^{-3}$ | A | A | A | B | C |
| Probable | Likely to occur many times | $2.8 \times 10^{-3} - 2.8 \times 10^{-4}$ | A | A | B | C | D |
| Occasional | Likely to occur sometimes | $2.8 \times 10^{-4} - 2.8 \times 10^{-5}$ | A | B | C | D | D |
| Remote | Unlikely to occur | $2.8 \times 10^{-5} - 2.8 \times 10^{-6}$ | A | C | D | D | D |
| Improbable | Very unlikely to occur | $2.8 \times 10^{-6} - 1.55 \times 10^{-8}$ | A | D | D | D | D |
| Incredible | Extremely unlikely to occur | $<1.55 \times 10^{-8}$ | B | D | D | D | D |

2. ► All risks need to be reduced ALARP iaw the “Health and Safety at Work Act” and Health and Safety Executive. ◀

⁴ A controlled flying hour is an hour of an aircraft’s flight time for which an Air Traffic service is received.

Intentionally blank for print pagination

RA 3132 - Air Traffic Management Equipment Safety Cases

Rationale

► *Air Traffic Management (ATM) Equipment types are complex and often have unique and emerging capabilities that present complicated developmental challenges; moreover, the operation of ATM Equipment presents a foreseeable and credible Risk to Life (RtL). A simple Risk Assessment will not be sufficient to assess the potential impact of these RtL, whereas the use of a Safety Case (SC) provides the ability to understand the cumulative and / or interrelated Risks from the use of the complex equipment. This Regulatory Article (RA) requires that all ATM Equipment has a robust SC that will demonstrate that the ATM equipment is, or will be capable of being, safe to operate and operated safely for a given application in a given operating environment.* ◀

Contents

- 3132(1): Air Traffic Management Equipment Safety Cases
- 3132(2): Responsibilities of Duty Holder-Facing Organizations
- 3132(3): Air Traffic Management Equipment Safety Case Management Process
- 3132(4): Air Traffic Management Equipment Safety Case Amendments
- 3132(5): Air Traffic Management Equipment Safety Case Reports
- 3132(6): Air Traffic Management Equipment Safety Case Independent Assessment
- 3132(7): Specific Site / Operating Area Safety

Regulation 3132(1)

Air Traffic Management Equipment Safety Cases

3132(1) The Delivery Team (DT) ►¹ ◀ **shall** be responsible for ensuring that a 4-part ATM Equipment SC is developed for all new and significantly² modified ATM Equipment.

Acceptable Means of Compliance 3132(1)

Air Traffic Management Equipment Safety Cases

1. The 4-part ATM Equipment SC³ **should** show that Risks are reduced so that they are As Low As Reasonably Practicable (ALARP) and Tolerable, through auditable and evidence-based arguments.
2. The approach described in Def Stan 00-56⁴ **should** be adopted for the auditable production of SCs.
3. The ATM Equipment SC **should** clearly describe the evidence and arguments used to justify the Safety of the equipment and its operation, so that agreement can be reached on the validity of the conclusions. It will be structured hierarchically, and the Safety justification summarized in a series of ATM Equipment SC Reports (SCRs).
4. An ATM Equipment SC **should** provide evidence that:
 - a. Safety requirements have been met.
 - b. Hazards have been adequately identified and analyzed, and associated Risks assessed in an appropriate manner.
 - c. All identified Hazards and Accidents have been addressed and controls applied, to ensure all residual Safety Risks have been reduced so that they are ALARP and Tolerable.

¹ ► Any reference to a DT within this RA also includes any organization responsible for delivering ATM Equipment, whether or not they are a Defence Equipment & Support (DE&S) DT; this includes Platform Authorities and other project teams with a similar remit. ◀

² See para 10.

³ Based on industry good practice.

⁴ Refer to Def Stan 00-56 – Safety Management Requirements for Defence Systems.

**Acceptable
Means of
Compliance
3132(1)**

- d. The system complies with all relevant Safety legislation, Regulations and standards.
 - e. All measures have been taken to ensure that Safety levels achieved can be sustained through life, both in operation of the system and through support.
 - f. The service can be terminated safely and the systems can be disposed of safely.
5. An ATM Equipment SC **should** demonstrate how Safety has been, is being and will be achieved and maintained.
 6. The 4 parts of the ATM Equipment SC **should** be:
 - a. Part 1 - Requirements. This part **should** establish and refine the Safety requirements for the system and the likely Safety Risks that the implementation of the User Requirement Document (URD) may present (eg a Preliminary Hazard Identification).
 - b. Part 2 - Design. This part provides the justification and evidence that a system is safe and suitable for its designed purpose (including demonstrating that the system complies with applicable Safety, operating and Maintenance Regulations). If more than one capability option is being explored the ATM Equipment SC Part 2 **should** be initiated during the Assessment phase, and when a solution is identified, the ATM Equipment SC Part 2 **should** be progressively refined and updated for the chosen solution alongside its Development and Manufacture.
 - c. Part 3 - Introduction to service. This part **should** provide evidence that the installation and transition will be safe and provide details of the proposed testing and commissioning plan, and any fallback options. Depending on the installation and transition arrangements this may have site specific elements within it.
 - d. Part 4 - In-Service. This part **should** provide details of how the equipment will be operated safely and includes any specific configuration issues or limitations from the Release into Service Process (RiSP)⁵. The ATM Equipment SC Part 4 will contain generic and site specific information. This could lead to one document for each site or annexes to a main document.
 7. The users requirements are instrumental to the ATM Equipment SC Part 1 and **should** include definitions of Risk tolerability and Safety budget apportionment.
 8. If other related SCs are already in existence they **should** be integrated as necessary, this may include integration with other ATM Equipment SCs or as input into Air Systems SCs and ship SCs.
 9. Any dependencies on other organizations **should** be recorded in the ATM Equipment SC.

**Guidance
Material
3132(1)**

Air Traffic Management Equipment Safety Cases

10. For the purposes of this Regulation modifications will be classed as significant when:
 - a. They change the way components of the functional system are used; or
 - b. The changes to equipment, either hardware or software, could affect the functional performance of the ATM equipment; or
 - c. The changes affect equipment configuration, excluding changes during Maintenance, repair and alternative operations that are already part of the accepted operational envelope; and

⁵ Refer to RA 3134 – Air Traffic Management Equipment Release into Service Process.

**Guidance
Material
3132(1)**

- d. They are not classified as minor in accordance with RA 3134(1)⁶.
11. A SC is defined as a structured argument, supported by a body of evidence that provides a compelling, comprehensible and valid case that a system is safe for a given application in a given operating environment⁴.
12. The degree of evidence required, and work involved in developing an ATM Equipment SC will be commensurate with the Risk posed by a particular system, its complexity and maturity.
13. The generation of an ATM Equipment SC is an iterative process and will start at the beginning of the system's / equipment's lifecycle.
14. The DE&S Project Orientated Safety Management System (POSMS) provides procedures and examples of good practice for developing SCs.
15. It is expected that the ATM Equipment SC Part 1 will contain the following information:
- a. Scope and assumptions.
 - b. User requirements or a reference to the URD.
 - c. Safety requirements and targets.
 - d. The equipment's operating context and environment.
 - e. Legislative and regulatory requirements.
 - f. Reference to appropriate MOD policy.
 - g. Military and civil standards to be complied with.
 - h. Any Safety Risks generated by the implementation of the URD.
 - i. Risk targets, tolerability criteria and the application of the ALARP principle.
 - j. Safety integrity requirements and derived Safety requirements.
 - k. Criteria against which the Safety performance will be measured.
16. It is expected that the ATM Equipment SC Part 2 will contain the following information:
- a. Details of the equipment design and function.
 - b. Demonstration that the equipment design meets the requirements set out in the ATM Equipment SC Part 1 and the System Requirements Document (SRD).
 - (1) This is to include demonstrating compliance with applicable legislation and Regulations, and more importantly where it does not comply.
 - c. Justification and evidence that the equipment is safe and suitable for its required purpose.
 - d. Evidence that there are no unsafe interactions with other equipment and that any required interactions / dependencies work correctly.
 - e. Evidence of how Risks have been mitigated through the design and details of remaining Risks that are mitigated through procedures.
 - f. The Hazard Log.
 - g. Demonstration that remaining Risks have been reduced so that they are ALARP and Tolerable.
17. It is expected that the ATM Equipment SC Part 3 will contain the following information:
- a. Confirmation that all Safety requirements have been met and Hazards are at a level where they can be agreed by the Aviation Duty Holder-Facing

⁶ Refer to 3134(1): Air Traffic Management Equipment Release into Service Process.

**Guidance
Material
3132(1)**

organization and highlighted to the relevant Duty Holder (DH) where appropriate.

- b. Details of the installation, testing and commissioning and transition plan / processes for the equipment and people, and where required platform integration.
- c. Evidence that the installation, testing and commissioning and transition processes are acceptably safe.
- d. Any dependencies on other equipment and how this will be managed and assured.

18. It is expected that the ATM Equipment SC Part 4 will contain the following information:

- a. How the equipment will be operated In-Service (including site specifics) which will include people, processes and equipment, eg Maintenance and training policies and operating procedures / documentation.
- b. Limitations of use and Safety related restrictions which have been imposed on the operation of the equipment. Limitations may come from the design, Risk mitigations or the RiSP.
- c. Any specific configurations for the site / operating area.
- d. Emergency and contingency arrangements and measures to ensure provision of adequate escape and / or emergency arrangements, if Accidents were to occur.
- e. Safety performance monitoring arrangements.
- f. The process for making changes to the In-Service operation and the associated ATM Equipment SC changes.

**Regulation
3132(2)**

Responsibilities of Duty Holder-Facing Organizations

3132(2) DH-Facing organizations involved in the provision of ATM **shall** be accountable to DHs for the provision of ATM Equipment SCs.

**Acceptable
Means of
Compliance
3132(2)**

Responsibilities of Duty Holder-Facing Organizations

19. Commanders and Accountable Managers in DH-Facing organizations **should** be individually accountable to DHs for the performance, Safety and integrity of those ATM Equipment SC elements for which they are responsible or the services that they provide. Their responsibilities **should** be laid down in an auditable manner.

**Guidance
Material
3132(2)**

Responsibilities of Duty Holder-Facing Organizations

20. Examples of DH-Facing organizations in the context of RA 3132(2) are Air Command Air Officer Battlespace Management, Fleet Capability Aviation Operations Support, Joint Helicopter Command Safety and Policy and the DE&S TEST DT.

**Regulation
3132(3)**

Air Traffic Management Equipment Safety Case Management Process

3132(3) The ATM Equipment SC **shall** be managed through the Project Safety Panel (PSP).

**Acceptable
Means of
Compliance
3132(3)**

Air Traffic Management Equipment Safety Case Management Process

21. Initially each part of the ATM Equipment SC **should** be authorized for release in order; however, development of the next part of the ATM Equipment SC can begin prior to the previous part being authorized for release.

**Acceptable
Means of
Compliance
3132(3)**

22. When a new project is being established the DT **should** contact the relevant DH-Facing organizations, Front Line Commands (FLC) and end users requesting they provide details of the nominated posts that will be PSP members and details of who will authorize the ATM Equipment SC (including accepting Risks where required).
23. Terms of Reference **should** exist for the PSP stating each member's role and responsibilities.
24. The PSP **should** be chaired by the Delivery Team Leader (DTL) or Delivery Manager. The minimum membership **should** be:
- DT staff, including the Safety staff / team.
 - Equipment designers / contractors.
 - Relevant DH-Facing organizations, FLC and end users (operators, maintainers etc).
 - The Independent Safety Auditor (ISA).
25. Staff from organizations that will be part of the RiSP **should** be invited to PSPs in the project's later stages.
26. The PSP minutes **should** provide an auditable trail of discussions, actions, and agreements.
27. All PSP members **should** be a Suitably Qualified and Experienced Person (SQEP). All members, replacements and representatives **should** complete SQEP forms at their first meeting. Completed SQEP forms **should** be held within the DT. If members details change (eg experience or qualifications) they **should** notify the chair and update their form.
- SQEP forms **should** clearly state the Area of Responsibility for each PSP member.
28. Each phase of the ATM Equipment SC **should** be owned by the appropriate organization:
- Part 1. Owned and written by the DT, however the content, ie requirements, **should** come from the relevant DH-Facing organizations, FLC and end users and stakeholders.
 - Part 2. Owned by the DT but predominantly written by the contractors responsible for designing the equipment or Safety consultants.
 - Part 3. Owned by the DT with input from contractors, relevant DH-Facing organizations, FLC, end users and stakeholders.
 - Part 4. Owned by the relevant DH-Facing organizations or FLCs, however on initial creation it will be predominantly written by the DT and contractors with input on procedures and processes from FLCs, end users and stakeholders.
 - (1) Once the equipment is In-Service it will be responsibility of the relevant DH-Facing organizations, FLCs and end users to maintain the ATM Equipment SC Part 4.
29. The ATM Equipment SC **should** be managed within current structures as a routine part of capability generation and employment.
30. When each part of the ATM Equipment SC and the associated reports are agreed by the PSP, all PSP members **should** recommend that it be authorized for release by the appropriate persons and their recommendations **should** be minuted.
31. Each part of the ATM Equipment SC **should** be authorized for release by the following:
- Part 1. DTL.
 - Part 2. DTL and relevant DH-Facing organizations / FLC. By authorizing this part the relevant DH-Facing organizations / FLC are confirming the procedural mitigations are acceptable and the residual Risks are at a level where they can be agreed by the DH-Facing organization, having highlighted

Acceptable Means of Compliance 3132(3)

- them to the relevant DH where appropriate. These Risks will be those that have not been designed out.
- c. Part 3. DTL and relevant DH-Facing organizations / FLC.
32. Part 4. DTL and relevant DH-Facing organizations / FLC.

Guidance Material 3132(3)

Air Traffic Management Equipment Safety Case Management Process

33. Where there is more than one relevant DH-Facing organizations, FLC or end user they may agree to empower one organization (eg have a lead service) to authorize the parts of the ATM Equipment SC on their behalf. If they elect not to empower a single organization, authorization would be required from all parties to proceed on to the next part.
34. Those required to authorize each part may send their Subject Matter Experts to PSP meetings to represent them, however authorization cannot be delegated.
35. For oversight and Assurance purposes, the MAA may be in attendance at PSP meetings.
36. The FLCs may delegate management of the ATM Equipment SC Part 4 to individual sites but not ownership.
37. Annex A summaries the ATM Equipment SC management process.

Regulation 3132(4)

Air Traffic Management Equipment Safety Case Amendments

3132(4) The ATM Equipment SC owner **shall** keep it current throughout the life of the equipment.

Acceptable Means of Compliance 3132(4)

Air Traffic Management Equipment Safety Case Amendments

38. When there is a change to the ATM Equipment, operating procedures, equipment use and configuration, or the environment is not covered by the existing ATM Equipment SC, the case **should** be revised as follows:
- a. For **significant** changes or changes with a large Safety impact, as a complete re-issue of the relevant part(s).
 - b. For minor changes with little Safety impact, a Safety statement **should** be produced as an annex to the relevant part(s).
 - c. Once the equipment is In-Service the ATM Equipment SC **should** be reviewed and amended on a regular basis, not exceeding 4 years.
39. If an Incident, Accident or failure occurs the ATM Equipment SC **should** be reviewed and updated with details to mitigate against reoccurrence. The review **should** also include a review of the Hazards and mitigations, to ensure they remain current.
40. Amendments **should** be published and publicized to the Regulated Community in a timely fashion.

Guidance Material 3132(4)

Air Traffic Management Equipment Safety Case Amendments

41. For the purposes of RA 3132(4) **the description of significant change is detailed in paragraph 10 of this RA.**
- a. **▶▶**
 - b. **▶▶**
 - c. **▶▶**
 - d. **▶▶**
 - (1) **▶▶▶▶**
 - e. **▶▶**

**Regulation
3132(5)**

Air Traffic Management Equipment Safety Case Reports

3132(5) ATM Equipment SCs **shall** be summarized by a series of ATM Equipment SCRs.

**Acceptable
Means of
Compliance
3132(5)**

Air Traffic Management Equipment Safety Case Reports

42. ATM Equipment SCRs **should** summarize the arguments and evidence of the SC, and document progress against the Safety programme.

43. An ATM Equipment SCR **should** describe as a minimum the following:

- a. Capability or concept being assessed.
- b. Risk Assessment process.
- c. Requirements derived.
- d. Applicable Regulations.
- e. Potential Safety Risks.
- f. Measures to control them.
- g. Detail on assumptions made and shortcomings in knowledge and propose a strategy to deal with such issues.

44. ATM Equipment SCRs **should** be generated at key stages in the project as agreed by the PSP.

**Guidance
Material
3132(5)**

Air Traffic Management Equipment Safety Case Reports

45. A SCR is a key deliverable that summarizes the SC at a particular point in time. It provides Assurance that Safety is being managed effectively, highlights areas of Safety-related project Risk requiring management attention and gives stakeholders visibility of the status of the SC⁴.

**Regulation
3132(6)**

Air Traffic Management Equipment Safety Case Independent Assessment

3132(6) The ATM Equipment SC owner **shall** ensure the ATM Equipment SC is independently assessed.

**Acceptable
Means of
Compliance
3132(6)**

Air Traffic Management Equipment Safety Case Independent Assessment

46. During initial ATM Equipment SC development, or amendment due to **significant** changes, the ATM Equipment SC **should** be subjected to independent assessment.

**Guidance
Material
3132(6)**

Air Traffic Management Equipment Safety Case Independent Assessment

47. The primary role of an ISA is assessment and validation of the ATM Equipment SC work.

48. The ISA will have a well-defined role that is clearly understood by all parties. This role might include providing Assurance by auditing the Safety process being followed, or by doing some Safety Assessment independently to check the primary assessment. The role may change at different points through the life cycle, but the ISA's independence will not be compromised.

49. The ISA will be contracted exclusively by the DT to act on its behalf and not via the Prime Contractor and / or Designer; noting that if the MOD has the required competence, and based on the level of acceptable Risk, then this technical evaluation could be provided from within the DT.

**Guidance
Material
3132(6)**

50. It is acceptable for the ISA to be involved in the joint working environment between the DT and Designer. Duplication of effort will be avoided if the ISA works collaboratively with the MOD and Designer so that their assessments can be incorporated in the overall project schedule. It is important that the ISA work is conducted on behalf of the DTL and any advice they may have about the design and / or Safety will be directed to the DTL.

**Regulation
3132(7)**

Specific Site / Operating Area Safety

3132(7) The ATM Equipment SC Part 4s or the associated ATM Equipment SCR for all the equipment at a specific site / operating area **shall** be held on site and **shall** provide evidence that the site / operating area is safe.

**Acceptable
Means of
Compliance
3132(7)**

Specific Site / Operating Area Safety

51. The ATM Equipment SC Part 4 **should** contain the outcome of the ATM Equipment RiSP. This **should** include:

- a. A statement of outcome from the ATM Acceptance process.
- b. A statement of outcome from the relevant Site Specific Acceptance and Commissioning Board.

52. The ATM Equipment SC Part 4 (and ATM Equipment SCRs) for each site / operating area / equipment **should** contain sufficient information such that when combined for a site they make up the majority of what was previously termed a Terminal / Air Surveillance and Control System (ASACS) SC for ATM operations at that site. The remainder of the information required to provide the complete Safety argument (ie a Terminal / ASACS SC) **should** be written by the FLC.

53. Part 4 of the ATM Equipment SC (or ATM Equipment SCRs) **should** make reference to operating and engineering manuals and documents, training plans, staff qualifications and authorizations and site specific information, including interactions / dependencies with other equipment.

**Guidance
Material
3132(7)**

Specific Site / Operating Area Safety

54. The ATM Equipment SC Parts 1, 2 and 3 can be held centrally, there is no requirement for them to be held at each site.

ANNEX A

3132(3) ATM EQUIPMENT SAFETY CASE MANAGEMENT PROCESS

Figure 1. ATM Equipment SC Management Process.

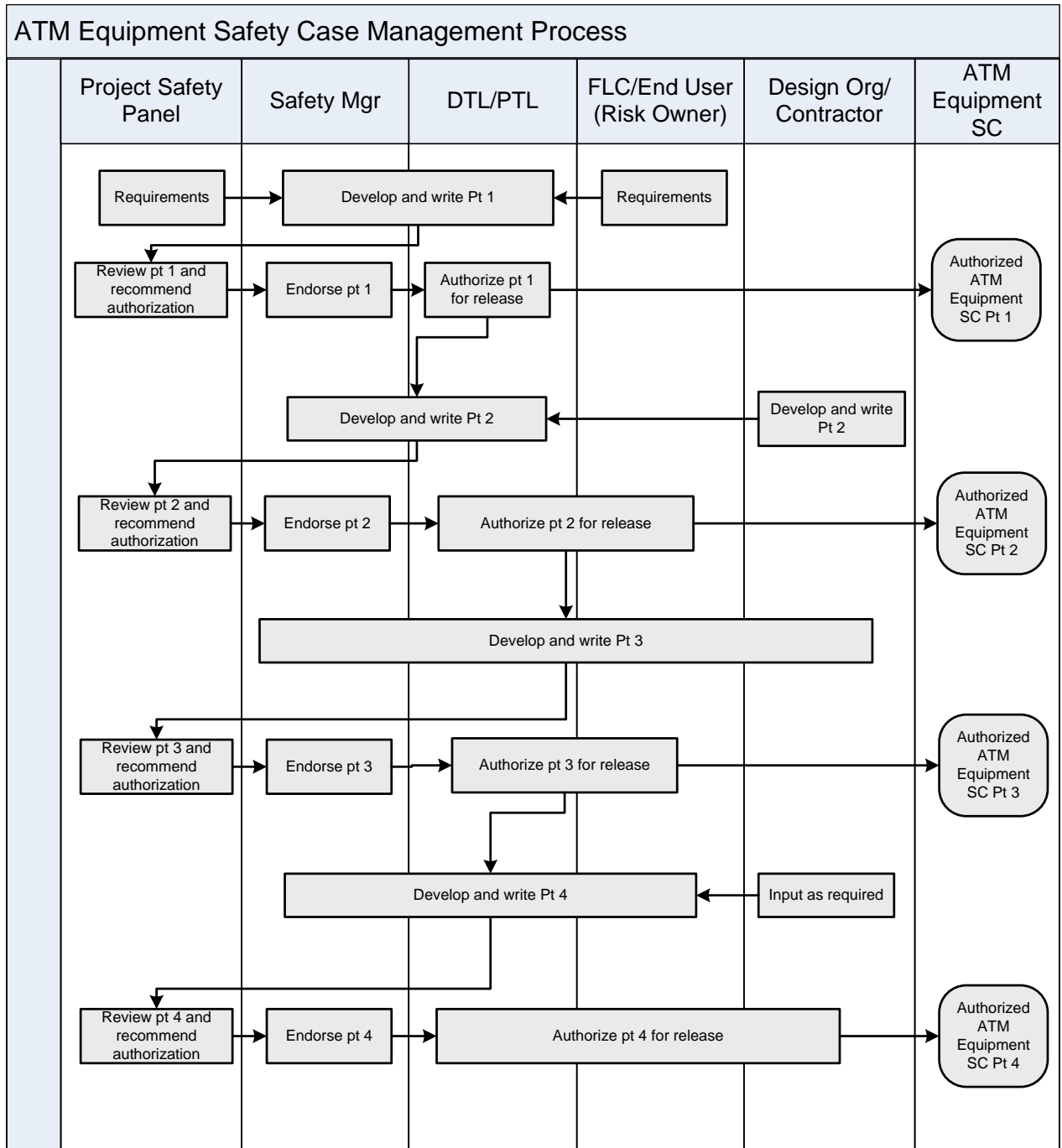

Intentionally blank for print pagination

► This RA / Manual has been re-formatted for clarity and withdrawn Sub-Regulations / Chapters have been removed. Other amendments have been made and change marks presented ◀

RA 3134 - Air Traffic Management Equipment Release into Service Process

Rationale

There is a requirement to ensure that new and significantly modified Air Traffic Management (ATM) Equipment is assessed to ensure that it is safe to operate and fit for purpose in enabling the provision of a safe and expeditious Air Traffic Service (ATS) prior to its release into service and consequent operation. ► Without such a process, there is a Risk that equipment may enter service without an assured understanding of the cumulative and / or interrelated Risks that the equipment may present. ◀ The requirement ensures not only that the generic equipment is safe but that its use, either independently or as part of an integrated ATM system on a specific platform / site / operating area, is also safe and that any limitations in its use or the service provided are captured.

Contents

3134(1): Air Traffic Management Equipment Release into Service Process

3134(2): Release into Service Strategy

3134(3): Release into Service Exposition

3134(4): Air Traffic Management Equipment Acceptance Board

3134(5): Site Specific Acceptance and Commissioning Board

3134(6): Release into Service Process Audit Trail

Regulation 3134(1)

Air Traffic Management Equipment Release into Service Process

3134(1) ► Aviation Duty Holder-Facing Organizations and Accountable Manager (Military Flying)-Facing Organizations (AA-Facing Organizations)¹ shall ensure that ◀ the ATM Equipment Release into Service Process (RiSP) ► is ◀ followed prior to any new or significantly modified equipment entering service to ensure the equipment is safe to operate and fit for the purpose of enabling the provision of a safe and expeditious ATS.

Acceptable Means of Compliance 3134(1)

Air Traffic Management Equipment Release into Service Process

1. Explicit requirements and derived Safety requirements clearly defining the ATM capability **should** be developed in order to identify the appropriate ATM equipment required prior to procurement / contract award.
2. ► ◀
 - a. ► ◀
 - b. ► ◀
 - c. ► ◀
 - d. ► ◀

¹ ► For clarity, throughout this Regulatory Article (RA), the term AA-Facing Organization may include, but not be limited to Delivery Teams (or equivalent), and ATM Organizations covering both the end users of ATM Equipment and their higher headquarters. Further detail is contained in RA 1032 – Aviation Duty Holder-Facing Organizations and Accountable Manager (Military Flying)-Facing Organizations - Roles and Responsibilities. ◀

**Acceptable
Means of
Compliance
3134(1)**

3. The process **should** be initiated by the relevant Senior Responsible Owner (SRO) and / or lead **▶ATM Organization◀** in consultation with the Delivery Team (DT)**▶◀** and stakeholders as part of initial Safety Management planning.
4. The strategy for the development of the ATM Equipment Safety Case (SC)³ **should** be aligned with the ATM Equipment RiSP and be described in the RiSS.
5. For the purposes of this Regulation, Modifications **should** be classed as significant when:
 - a. They change the way components of the functional system are used⁴; or
 - b. The changes to equipment, either hardware or software, could affect the functional performance of the ATM equipment⁵; or
 - c. The changes affect equipment Configuration⁶, excluding changes during Maintenance, Repair and alternative operations that are already part of the accepted operational envelope. **▶◀**
 - d. **▶◀**
6. **▶Minor Modifications are not routinely subject to the RiSP⁷. Notwithstanding the requirements at paragraph 5, if a DT classifies a Modification as minor, Form 1430⁸ should be submitted, with sufficient evidence, to the MAA for review, the outcome of which will determine whether the RiSP is required.◀**

**Guidance
Material
3134(1)**

Air Traffic Management Equipment Release into Service Process

7. It is imperative that those responsible for setting ATM Equipment requirements understand the Air Safety implications of doing so and ensure that comprehensive requirements and derived Safety requirements are agreed by all the stakeholders prior to contract award. Knowledge in Defence⁹, Acquisition Safety **▶and Environmental◀** Management System, the MAA Regulatory Publications and Royal Navy (RN) Books of Reference provide a robust framework to enable procurement of equipment that is safe to operate and fit for purpose.
8. When determining the significance of a Modification, consideration is to be given to any previous relevant changes that could create a cumulative effect, as these may influence the decisions regarding the classification of the change later in the process.
9. By previous relevant changes, it is meant those design changes whose effects accumulate, such as incremental software Modifications. Any previous relevant design changes in the area affected by the current change are to be considered when determining whether a Modification may be classed as significant.
10. Similarly, careful consideration is to be given to Modification of dual-Role Equipment¹⁰ to ensure that the performance integrity of the ATM elements is not compromised by changes to other functional elements.
11. Examples of changes to the way a functional system is used could be using a surveillance radar to provide 3 Nautical Miles (NM) separation when the equipment had previously been assured to provide 5 NM separation or a change in an Instrument Landing System approach category.

² **▶For clarity, throughout this RA, the term DT may also include any organization responsible for delivering ATM Equipment, whether or not they are a Defence Equipment & Support (DE&S) DT; this includes Platform Authorities and other project teams with a similar remit.◀**

³ Refer to RA 3132 – Air Traffic Management Equipment Safety Cases.

⁴ See paragraph 11.

⁵ See paragraph 12.

⁶ See paragraph 13.

⁷ **▶There may be occasions when the RiSP is appropriate for a minor Modification, for example if a series of minor Modifications create a larger cumulative effect to the ATM Equipment in question.◀**

⁸ Refer to MAA Form 1430: Air Traffic Management Equipment Minor Modification Review. **◀**

⁹ Online resource which provides a structured source of information, guidance and instruction for everyone who works in Acquisition, whether they are MOD or Industry. The Knowledge in Defence is a set of documents that explain how Acquisition business is conducted.

¹⁰ For example, Air Defence or ship borne missile defence radars that also provide an ATM Safety function.

Guidance Material 3134(1)

12. Examples of changes to equipment, either hardware or software, that could affect the functional performance of the ATM equipment could be a radar transmitter upgrade or a new signal processing software release. This does not apply to form, fit, function changes or Modifications to dual role systems that do not have the potential to impact ATM functional performance.
13. Examples of changes that affect equipment Configuration could be the changes to Moving Target Indicator marker Configuration or changes to radar optimization settings not covered by the scope of the equipment SC.
14. This includes Modification to legacy ATM equipment¹¹.
15. ► The MAA will aim to provide an initial response to Form 1430 requests within 20 working days. ◀
16. The MAA ATM Certification team (DSA-MAA-MRPEnquiries@mod.gov.uk) are available to address any regulatory or Safety queries.

Regulation 3134(2)

Release into Service Strategy

- 3134(2) The DT ► ◀ shall ► prepare a Release into Service Strategy (RiSS) for ◀ the MAA ► detailing ◀ how new / significantly modified equipment will progress through the RiSP.

Acceptable Means of Compliance 3134(2)

Release into Service Strategy

17. The RiSS should:
- a. ► Be developed in consultation with the relevant ATM Organization and Release To Service Authority (RTSA), as required. ◀
 - b. Define the type and extent of ATS provided.
 - c. Define the Defence Standard (Def Stan) 00-972 requirements or Alternative Acceptable Means of Compliance against which the ATM Equipment is to be assured.
 - d. Define external system and service interfaces.
 - e. Define the allocation of Safety responsibilities¹². ► ◀
 - f. Define ATM Approved Organization Scheme¹³ requirements.
 - g. Define pan-Defence Lines of Development (DLod) responsibilities.
 - h. Define project timescales and milestones where appropriate.
 - i. Define the Safety programme timescales and Safety milestones where appropriate.
 - j. ► Define any claims for Assurance credit in accordance with (iaw) the Manual of Military Air Traffic Management Equipment Assurance (MMATMEA)¹⁴, including sufficient evidence for MAA consideration of acceptance. ◀
 - k. Be reviewed by the MAA and RTSA and authorized by the Project Safety Panel (PSP)¹⁵, prior to issue of an Invitation To Tender (ITT).
 - l. ► Be formally accepted by the SRO, with documented agreement from the MAA and the RTSA. ◀

¹¹ Refer to RA 3120 – Air Traffic Management Equipment Standards.

¹² Refer to RA 3130 – Air Traffic Management Equipment Safety Management.

¹³ Refer to RA 3100 – Air Traffic Management Equipment Approved Organization Scheme.

¹⁴ ► In addition to the conditions outlined in Chapter 4 of the MMATMEA, consideration of Assurance credit is also available for equipment that has been previously assured through the RiSP for a different installation. ◀

¹⁵ Refer to RA 3132(3): Air Traffic Management Equipment Safety Case Management Process.

**Guidance
Material
3134(2)**

Release into Service Strategy

18. It is important that prior to ITT the Def Stan 00-972 ►/ **appropriate equipment** ◀ requirements applicable to the equipment being modified or brought into service are fully understood. Failure to do so has the potential to cause significant additional costs or increased Duty Holder (DH) Risk later in the project. The RiSS ought to include a summary of the applicable Def Stan 00-972 ►/ **appropriate equipment** ◀ requirements and those which will require further discussion with the MAA before being deemed non-applicable or out of scope.

19. ► **Evidence of formal acceptance by the SRO and documented agreement from the MAA and RTSA may be achieved by completion of suitable signature blocks on the RiSS itself.** ◀

**Regulation
3134(3)**

Release into Service Exposition

3134(3) The ► **DT** ◀ or equivalent **shall** prepare a RiSE for the MAA and RTSA which will be Audited by the MAA to provide Assurance of the underpinning evidence.

**Acceptable
Means of
Compliance
3134(3)**

Release into Service Exposition

20. The RiSE **should** comprise the body of evidence that underpins the safe introduction of ATM Equipment into service. The RiSE **should**:

- a. Include parts 1, 2 and 3 of the ATM Equipment SC or the most recent ATM Equipment SC reports.
- b. Include a draft of the ATM Equipment SC part 4.
- c. Include a statement from the ► **DT** ◀ that parts 1-3 of the ATM Equipment SC have been signed and authorized iaw RA 3132³.
- d. Provide evidence that the equipment meets all the appropriate legislative requirements, Regulations and Safety Targets.
- e. Provide details of how the equipment will be brought into service.
- f. Identify all shortfalls against Requirements and non-compliance with Regulation.
- g. Include any restrictions on the operation of the equipment.

21. The MAA **should** Audit the RiSE and provide formal recommendation to the RTSA as to whether there is enough evidence to assure a full release.

**Guidance
Material
3134(3)**

Release into Service Exposition

22. The purpose of the MAA Audit is to:

- a. Assure that the ATM Equipment is designed and built to a defined and recognized standard¹¹ and by a Competent organization¹³.
- b. Provide independent Assurance to the RTSA that the ATM Equipment is fit for the intended purpose.

**Regulation
3134(4)**

Air Traffic Management Equipment Acceptance Board

3134(4) An ATM Equipment Acceptance Board (EAB) **shall** be convened to confirm that any new or significantly modified ATM equipment is ready to be released for installation / commissioning on a specific platform / site / operating area.

**Acceptable
Means of
Compliance
3134(4)**

Air Traffic Management Equipment Acceptance Board

23. The Board **should** be convened¹⁶ and chaired by the relevant RTSA.
 - a. For afloat ATM Equipment the RN RTSA **should** take the lead.
 - b. For land ATM Equipment the RAF RTSA **should** take the lead.
 - c. For air-based ATM Equipment the RAF RTSA or RN RTSA **should** take the lead, as deemed appropriate.
24. The Board **should** consist of Suitably Qualified and Experienced ► **Persons** ◀ and include ATM operators / maintainers as appropriate.
25. The Board **should** liaise with the ► **DT** ◀ to ensure they have all the evidence required.
26. The Board **should** be provided with the RiSE Audit Report (RiSAR).
27. The Board **should** be responsible for providing Assurance that the RiSE successfully argues:
 - a. The equipment to be released meets the regulatory requirements.
 - b. All Safety requirements have been met and Hazards are at a level where they can be agreed by ► **all AA-Facing Organizations** ◀ and highlighted to the relevant ► **ADH / AM(MF)** ◀ where appropriate.
 - c. The required Safety processes have been followed.
 - d. All the required Safety documentation is available.
28. The Board **should** assess whether all DLoDs are at an appropriate level of maturity such that their effects upon the Equipment DLoD can be verified prior to initial issue of an equipment release.
29. The Board **should** establish whether the equipment can be Fully Released (Full Release), Released with Limited Evidence (RLE), Released for Emergency Operational Use (Operational Emergency Release (OER)) or not released.
 - a. An RLE **should** be used when insufficient evidence is available to support the normal standards required for Full Release (ie when a fully substantiated ATM Equipment SC is not available to support the RiSP, but on the balance of available evidence, release is judged safe to operate and fit for the purpose of providing a safe and expeditious ATS). An RLE can become a Full Release only with the provision of suitable additional evidence. An RLE **should** be time-bounded whilst the required evidence is gathered.
 - b. An OER **should** be used when the Risk to Life associated with the ATM Equipment's usage is considered too high for normal day-to-day operations, but there is an operational requirement to use the equipment eg in conditions of actual or potential hostile enemy action, in the evaluation of options needed for contingency planning or in other conditions of operational imperative. An OER **should** have an expiry date associated with the operational need it is fulfilling.
30. The Board's decisions, including identifying and specifying the approved Configurations for the equipment, and the procedural Safety mitigations identified by the ATM Equipment SC **should** be included in the ATM Equipment SC part 4.
31. The final decision on whether to release equipment for installation / commissioning **should** be made by the Delegated Release To Service Authority (DRTSA) and formalized through the issue of a ► **Release To Service (RTS)**. ◀
32. The MAA **should** be invited to the Board.

¹⁶ The timing of the EAB within a project **should** be defined in the RiSS.

**Guidance
Material
3134(4)**

Air Traffic Management Equipment Acceptance Board

33. In addition to RTSA personnel the Board may include personnel from ► **all relevant AA-Facing Organizations** ◀ including the Independent Safety Advisor and Independent Technical Evaluator if required.
34. A Full Release may specify limitations on the equipment due to technical or environmental (location) constraints.
35. A RLE or OER can be made with or without full MAA Assurance as deemed necessary by the EAB.

**Regulation
3134(5)**

Site Specific Acceptance and Commissioning Board

- 3134(5) An ATM Equipment Site Specific Acceptance and Commissioning Board (SSACB) **shall** be held to confirm that any new or significantly modified ATM equipment is ready to be accepted into service on a specific platform / site / operating area.

**Acceptable
Means of
Compliance
3134(5)**

Site Specific Acceptance and Commissioning Board

36. The Board **should** be convened and chaired by either the Head of Establishment (HoE)¹⁷, ► **or Head of the relevant AA-Facing Organization** ◀, or their delegated representative as deemed most appropriate.
37. The Board **should** have appropriate representation from ► **relevant AA-Facing Organizations**, ◀ the RTSA, associated Contractor organizations, the installation team, site senior end user¹⁸, ATM equipment senior responsible engineer, Site Work Services, Site Coordinating Infrastructure Design Authority and / or other organizations as directed by the SSACB chairperson.
38. The Board **should**:
- Review the RiSAR and ► **RTS** ◀ to assure themselves that platform / site / operating area specific requirements and Safety issues have been addressed.
 - Review the ATM Equipment SC part 4 to confirm that the equipment will be operated safely.
 - Assess any platform / site / operating area specific issues regarding the installation and operation of the equipment at their platform / site / operating area.
 - Consider factors such as siting, interference, potential infringements, suitability of procedures, interoperability with host platform systems and any Risk mitigations for their platform / site / operating area.
 - Ensure that all the relevant documentation is available for the platform / site / operating area.
 - Confirm that all Safety Risk is assessed As Low As Reasonably Practicable and Tolerable.
39. The Board **should** agree any platform / site / operating area constraints that need to be added to their ATM Equipment SC part 4.
40. The Board's discussions and decisions **should** be recorded and kept with the platform / site / operating area ATM Equipment SC part 4.
41. The final decision on whether to accept equipment into service **should** be made by the SSACB chairperson.
42. The MAA **should** be invited to the SSACB.

¹⁷ ► Refer to RA 1010 – Head of Establishment Aviation Responsibilities and Aviation Duty Holder / Accountable Manager (Military Flying) Establishment Responsibilities. ◀

¹⁸ For example, Senior Air Traffic Control Officer.

**Guidance
Material
3134(5)**

Site Specific Acceptance and Commissioning Board

43. The purpose of including the HoE, ► **Head of the relevant AA-Facing Organization**, ◀ or their delegated representative, as SSACB chairperson is to provide flexibility to ensure the most appropriate accountable person for the safe delivery of the ATS accepts the equipment into service.
44. ► **ADH / AM(MF) representation may be invited to attend at the chairperson's discretion, particularly if acceptance of the equipment in question might impact the provision of a Safe Operating Environment (SOE). It is likely that this will be limited to those responsible for Aircraft based at the site in question, but this does not exclude others from attending if it is deemed necessary**¹⁹. ◀
45. For ATM Equipment being installed on ships or ► **Aircraft**, ◀ an SSACB may be held for each ► **Aircraft** ◀ type or ship class providing the infrastructure that the ATM Equipment uses is the same (eg power architecture) and the potential infringements are the same (eg structures and transmitting devices). This intention will have been articulated in the RiSS and forms part of the RiSE.

**Regulation
3134(6)**

Release into Service Process Audit Trail

- 3134(6) All Air Safety documents **shall** be maintained throughout the ATM Equipment's Service life and retained for a minimum of 5 years beyond the equipment's out of Service date.

**Acceptable
Means of
Compliance
3134(6)**

Release into Service Process Audit Trail

46. The output from the RiSP **should** be:
- Auditable and traceable back to the source data.
 - Maintained by the ► **DT** ◀ throughout the Service life of the equipment and appropriate data retained after the out of Service date.
47. Correct and meticulous registry procedures **should** be applied to ensure that the Audit trail²⁰ is maintained correctly.

**Guidance
Material
3134(6)**

Release into Service Process Audit Trail

48. Scanned copies of documents are acceptable as evidence.

¹⁹ ► **ADH / AM(MF) Safe Operating Environment responsibilities are detailed in RA 1010(6): Aviation Duty Holder / Accountable Manager (Military Flying) Safe Operating Environment Responsibilities**. ◀

²⁰ Refer to RA 1225 – Air Safety Documentation Audit Trail.

Intentionally Blank for Print Pagination

RA 3136 – Air Traffic Management Equipment Technical Safeguarding

Rationale

To prevent a degradation in coverage and reliability, Heads of Establishment (HoE) or Duty Holder-Facing (DH-Facing) organizations are required to actively manage the technical safeguarding¹ of all of the Air Traffic Management (ATM) Equipment sites within their Area of Responsibility.

Contents

3136(1): Head of Establishment / Duty Holder-Facing Organizations' Responsibilities

3136(2): Ministry of Defence Radio Site Protection Programme Manager Responsibilities

3136(3): Air Traffic Management Equipment Engineering Authority Responsibilities

3136(4): Headquarters Responsibilities

3136(5): Aviation Duty Holder Responsibilities – Operating within an infringed Air Traffic Management Equipment environment

Regulation 3136(1)

Head of Establishment / Duty Holder-Facing Organizations' Responsibilities

3136(1) HoE or DH-Facing organizations **shall** ensure that all ATM Equipment for which they are responsible is technically safeguarded.

Acceptable Means of Compliance 3136(1)

Head of Establishment / Duty Holder-Facing Organizations' Responsibilities

1. HoE or DH-Facing ► **organizations** ◀ **should** actively manage ATM Equipment Technical Safeguarding, in accordance with (iaw) JSP 604 ►²◀, for all ATM Equipment for which they are responsible.
2. HoE or DH-Facing organizations **should** maintain a register, to be included in the unit Defence Aerodrome Manual (DAM) and Defence Aerodrome Assurance Framework (DAAF)³, detailing, as a minimum, the information below in support of the Technical Safeguarding for all ATM Equipment for which they are responsible:
 - a. Type of ATM Equipment.
 - b. Known infringements⁴.
 - c. Map of ATM Equipment technical safeguarding zone, with infringements annotated.
 - d. Nature of the infringement.
 - e. Status of the infringement concession.
 - f. Infringement concession decision and supporting engineering appraisal.
 - g. Review period of the concession, if applicable.
 - h. Expiry of Concession, if applicable.
 - i. Aerodrome Operator / HoE assessment of the infringement's impact on Air Safety.

¹ Technical Safeguarding is the process employed to protect radio signals from being affected by physical or electromagnetic changes in their transmission environment.

² ► Refer to JSP 604, Part 2, Vol 2 leaflet 3032 MOD Radio Site Clearance and Protection. ◀

³ Refer to RA 1026 – Aerodrome Operator and Aerodrome Supervisor (Recreational Flying) Roles and Responsibilities. ►◀.

⁴ An infringement is any object, natural or ► **artificial** ◀, within the Ground Radio Installation site restriction.

Acceptable Means of Compliance 3136(1)

3. Defence Infrastructure Organization (DIO) Safeguarding **should** engage with Local Planning Authorities (LPAs) to receive copies of any applications for developments, within the vicinity of MOD ATM Equipment.
4. DIO Safeguarding **should** advise individual HoE or DH-Facing organizations of any applications for developments received from LPAs that are within the vicinity of ATM Equipment that HoE or DH-Facing organizations are responsible for.
5. HoE or DH-Facing organizations **should** assess all applications for developments received from LPAs, within the vicinity of ATM Equipment for which they are responsible, to assess whether the development may have the potential to infringe.
6. HoE or DH-Facing organizations **should** request an engineering appraisal of the infringed ATM Equipment from the MOD RSP Programme Manager and seek concession approval, as required, from the relevant Headquarters (HQ)⁵ iaw JSP 604^{▶2◀}.
7. HoE or DH-Facing organizations **should** promulgate any actual or possible reduction(s) in Air Traffic Services, relating to the Aerodrome for which they are responsible, as a result of infringed ATM Equipment through their DAM, Notice to Aviation or other Aeronautical Information as appropriate.

Guidance Material 3136(1)

Head of Establishment / Duty Holder-Facing Organizations' Responsibilities

8. Guidance material is contained in JSP 604^{▶2◀}.

Regulation 3136(2)

Ministry of Defence Radio Site Protection Programme Manager Responsibilities

- 3136(2) The MOD RSP Programme Manager **shall** undertake engineering appraisals of infringed ATM Equipment.

Acceptable Means of Compliance 3136(2)

Ministry of Defence Radio Site Protection Programme Manager Responsibilities

9. The MOD Programme Manager **should**, when requested, undertake an engineering appraisal of infringed ATM Equipment, iaw JSP 604^{▶2◀}.
10. The engineering appraisal **should** include recommendations, with a technical impact assessment, to enable a decision as to whether an infringement concession is approved.
11. The engineering appraisal **should** be sent to the originating HoE or DH-Facing organization for action, as appropriate.
12. A copy of the engineering appraisal **should** be sent to the appropriate HQ.
13. The MOD RSP Programme Manager **should** hold and maintain a Master Register for all MOD ATM Equipment with any associated infringements and standing concessions.

Guidance Material 3136(2)

Ministry of Defence Radio Site Protection Programme Manager Responsibilities

14. Guidance material is contained in JSP 604^{▶2◀}.

⁵ Relevant HQs include Air Traffic Management Force Command (ATM FC), Air Surveillance and Control Systems Force Command (ASACS FC), Navy Command Headquarters (NCHQ), Joint Helicopter Command (JHC) and Permanent Joint Headquarters (PJHQ) for Permanent Joint Operating Bases (PJOBS).

**Regulation
3136(3)**

**Air Traffic Management Equipment Engineering Authority
Responsibilities**

3136(3) ATM Equipment Engineering Authorities **shall** provide assistance to HoE, DH-Facing organizations, relevant HQs and the MOD RSP Programme Manager as required.

**Acceptable
Means of
Compliance
3136(3)**

**Air Traffic Management Equipment Engineering Authority
Responsibilities**

15. ATM Equipment Engineering Authorities **should** provide assistance to HoE, DH-Facing organizations, the MOD RSP Programme Manager and relevant HQs, as requested, to support the technical safeguarding of ATM Equipment. Examples of assistance include:

- a. Specialist technical reports.
- b. Design Authority support.
- c. Site restriction criteria for inclusion in JSP 604².

**Guidance
Material
3136(3)**

**Air Traffic Management Equipment Engineering Authority
Responsibilities**

16. Guidance material is contained in JSP 604².

**Regulation
3136(4)**

Headquarters Responsibilities

3136(4) Relevant HQ⁵ Commanders **shall** assess infringement concession requests and approve as appropriate.

**Acceptable
Means of
Compliance
3136(4)**

Headquarters Responsibilities

17. The relevant HQ Commander **should**, as requested, decide whether an infringement concession for ATM Equipment is approved.

18. The relevant HQ Commander **should** assess the infringement concession request, supporting engineering appraisal and HoE or DH-Facing organizations operational impact. The relevant HQ Commander **should** include an Assurance statement that all proposed DH-Facing mitigations are in place and inform the Aviation DHs (ADH).

19. Copies of the infringement concession decision **should** be sent to the originating HoE or DH-Facing organization and the MOD RSP Programme Manager.

20. The relevant HQ Commander **should** hold and maintain a register of all infringement concessions and associated decisions for which they are responsible.

21. The relevant HQ Commander **should** ensure that formalized agreements⁶ are in place with those Front Line Commands they are undertaking infringement concession activity on behalf of.

**Guidance
Material
3136(4)**

Headquarters Responsibilities

22. Guidance material is contained in JSP 604².

**Regulation
3136(5)**

**Aviation Duty Holder Responsibilities – Operating within an
infringed Air Traffic Management Equipment environment**

3136(5) ADHs **shall** identify the Risk to Life (RtL) created by operating within an infringed ATM Equipment environment.

⁶ Refer to RA 3140 – Air Traffic Management Equipment End to End Safety.

**Acceptable
Means of
Compliance
3136(5)****Aviation Duty Holder Responsibilities – Operating within an infringed Air Traffic Management Equipment environment**

23. ADHs **should** ensure that the RtL associated with operating in an infringed ATM environment is considered iaw RA 1210⁷.

24. When considering the RtL associated with operating in an infringed ATM Equipment environment, the ADH **should** take into account the mitigation provided by the relevant HQ iaw RA 3136(4).

**Guidance
Material
3136(5)****Aviation Duty Holder Responsibilities – Operating within an infringed Air Traffic Management Equipment environment**

25. Nil.

⁷ Refer to RA 1210 – Ownership and Management of Operating Risk (Risk to Life).

RA 3140 - Air Traffic Management Equipment End to End Safety

Rationale

Safety of Air Traffic Management (ATM) Equipment ► **will** ◀ be considered on an end to end basis. It ► **will take** ◀ into account all relevant organizations, services, ► **interfaces**, ◀ activities and processes. It needs to include all lines of development and all relevant areas whether internal or external to the MOD. The responsibilities of different organizations and suppliers ► **needs to** ◀ be coordinated to achieve a safe outcome. ► **This Regulatory Article (RA) requires that end to end Safety of all ATM Equipment is considered and managed to demonstrate that the ATM equipment is, or will be capable of being, safe to operate and operated safely.** ◀

Contents

3140(1): Interfaces

3140(2): Justification of Air Traffic Management Equipment Safety Case Assumptions

3140(3): Front Line Command Formal Agreements

Regulation

3140(1)

Interfaces

3140(1) The ► ◀ Delivery Team Leader (DTL) **shall** ensure all interfaces¹ and dependencies that could affect ATM Equipment Safety are subject to formalized agreements, regardless of the boundaries of a project.

Acceptable Means of Compliance 3140(1)

Interfaces

1. Formal agreements (eg Joint Business Agreements, Internal Business Arrangements and Service Level Agreements) **should** be used to formalize interfaces and dependencies:
 - a. The agreements **should** assist with providing evidence that services outside the project scope can meet the requirements of the project. Eg power, infrastructure, communications links.
2. The ► ◀ DTL **should** raise, as appropriate, formal agreements with:
 - a. Other relevant ► ◀ Delivery Teams.
 - b. MOD organizations providing ► **infrastructure and / or** ◀ services (eg Defence Infrastructure Organisation, Defence Equipment & Support, ► **Defence Digital** ◀, 90SU Third Line Spt).
 - c. Civilian organizations providing infrastructure ► **and / or** ◀ services (eg BT, ► **NATS** ◀).
3. Where the ► ◀ DTL issues a formal agreement, the ► ◀ DTL **should** coordinate the agreement creation (eg timeliness, responsibilities and coherence) and ensure that Safety and budgetary responsibilities are clearly identified.
4. Agreements **should** be periodically reviewed. The periodicity **should** be laid down in the agreement.

Guidance Material 3140(1)

Interfaces

5. Nil.

¹ Examples of interfaces are organizational relationships, reliance on the provision of a service outside the project boundaries (eg power, NATS radar feed), Safety Case (SC) relationships.

**Regulation
3140(2)**

Justification of Air Traffic Management Equipment Safety Case Assumptions

3140(2) The ► ◀ DTL **shall** ensure that ATM Equipment SCs provide evidence that the assumptions made regarding ► **infrastructure and / or** ◀ services provided external to the project and interfaces at the project boundaries are justified.

**Acceptable
Means of
Compliance
3140(2)**

Justification of Air Traffic Management Equipment Safety Case Assumptions

6. All assumptions in ATM Equipment SCs regarding interfaces and the provision of ► **infrastructure and / or** ◀ services (inside and outside the project scope) **should** be supported by evidence that the interface / ► **infrastructure /** ◀ service will behave as expected. Examples of suitable evidence are:

- a. Formal agreements.
- b. Reference to other Safety Cases.
- c. Test results. ► ◀
- d. ► **Performance information.** ◀

**Guidance
Material
3140(2)**

Justification of Air Traffic Management Equipment Safety Case Assumptions

7. Nil.

**Regulation
3140(3)**

Front Line Command Formal Agreements

3140(3) Front Line Commands (FLCs) **shall** ensure that any ► **infrastructure and / or** ◀ service that they provide or receive, or activity that they conduct on behalf of another organization, which impacts ATM Equipment Safety, is formalized with a documented agreement. This regulation **shall** apply to all current and future activity.

**Acceptable
Means of
Compliance
3140(3)**

Front Line Command Formal Agreements

8. The formalized agreement **should** include:
 - a. What the service / activity is (eg auditing, providing engineering Subject Matter Expert advice).
 - b. Details of who, how and when the activity will be conducted.
 - c. Expiry or review dates for the agreement.
 - d. Any monitoring or performance requirements (eg Key Performance Indicators).
 - e. Processes for information dissemination across both FLCs / organizations, including reporting chains for audit findings and responsibilities for corrective action, if appropriate.

**Guidance
Material
3140(3)**

Front Line Command Formal Agreements

9. An example of a formalized agreement suitable for this purpose is a Service Level Agreement.
10. Examples of where a formalized agreement may be required are:
 - a. Where an Release To Service Authority is conducting the Release into Service Process for other FLCs.
 - b. Where an FLC is conducting Assurance activity within a different FLC.

RA 3201 – Military Air Traffic Management

Rationale

Military Air Traffic Management (ATM) is provided to both military and civil registered Air Systems in airspace that is jointly managed with civil ATM agencies. ► **ATM covers Air Traffic Service (ATS) provision, airspace management and surface based functions including Aerodrome management.** ◀ Given the shared nature of airspace, a failure of Military ATM personnel to understand the framework under which they provide ATM could increase the Risk to Life (RtL) ► **such as** ◀ mid-air collision ► **or runway incursion.** ◀ This Regulatory Article (RA) details the constituent parts of Military ATM, the applicability of the MAA Regulatory Publications (MRP) and the interfaces with civil aviation regulation.

Contents

3201(1): Military Air Traffic Management

Regulation 3201(1)

Military Air Traffic Management

3201(1) Heads of Establishment (HoE) and Aviation Duty Holder (ADH)-Facing organizations **shall** ► **ensure** ◀ ATM ► **provision is** ◀ in accordance with (iaw) the MRP.

Acceptable Means of Compliance 3201(1)

Military Air Traffic Management

1. **ATS.** Where ATS is provided by the MOD, HoE and ADH-Facing organizations **should** ensure that it is provided iaw the ATM 3000 Series¹, Civil Air Publication (CAP) 774 UK Flight Information Services (UK FIS) and CAP 413 Radiotelephony Manual.
2. **Aerodrome Management.** HoE at Government Aerodromes² **should** ensure that Aerodrome Management is carried out iaw the RA 3500 Series³. HoE and ADH-Facing organizations **should** undertake oversight and assurance of Aerodrome Management activities iaw ► **RA 1010⁴** and ◀ RA 1026⁵.
3. **Airspace Management.** ATM personnel **should** operate iaw the requirements in CAP 740 UK Airspace Management Policy which forms the basis of a Joint and Integrated approach to airspace management within the UK. Prior to embarking on any Airspace Change Process (ACP), HoE and ADH-Facing organizations **should** first consult the Defence Airspace and Air Traffic Management (DAATM) organization to articulate their requirements and seek guidance on the appropriate manner to proceed.
4. **Qualifications.** ATM ► **should be carried out by a Suitably Qualified and Experienced Person (SQEP):**
 - a. **Force Headquarters (FHQ) should** issue orders that specify the SQEP criteria required to hold ATM positions which include ATS provision⁶, Air Traffic Control Management, Aerodrome Management and Airspace Management, in order to support HoE and ADH-Facing Organizations in fulfilling their duties iaw RA 1010⁴ and RA 1020⁷ respectively. FHQ **should** ensure that career management organizations allocate personnel in line with SQEP criteria.
 - b. Where nominees for key ATM positions do not meet the SQEP requirements, FHQ **should** assure the respective ADH / HoE of their decision in order to allow the ADH / HoE to accept any residual RtL. The MAA **should** be informed of the decision and the FHQ **should** maintain an auditable trail of the

¹ Refer to RA 3000 Series: Air Traffic Management Regulations.

² ► Refer to MAA 02: MAA Master Glossary. ◀

³ Refer to RA 3500 Series: Aerodrome Design and Safeguarding.

⁴ ► Refer to RA 1010 – Head of Establishment – Aviation Responsibilities. ◀

⁵ Refer to RA 1026 – Aerodrome Operator and Aerodrome Supervisor (Recreational Flying) Roles and Responsibilities including Aerodrome and Helicopter Landing Site Assurance Requirements.

⁶ ► Refer to RA 3202 – Air Traffic Service Provision – Qualifications and Entitlement, Training, Competence and Currency.

⁷ Refer to RA 1020 – Aviation Duty Holder and Aviation Duty Holder-Facing Organizations – Roles and Responsibilities. ◀

Acceptable Means of Compliance 3201(1)

decision making process, including engagement with career management organizations and the ADH / HoE. ◀

5. **Civil Contracted ATM.** Contracts for the provision of ATM personnel⁸ or services to provide ATM functions at Government ATM facilities **should** be let against the requirements of RA 1005(1)⁹ as follows:

a. **Contracts.** The MOD contract **should** clearly detail the applicability of the MRP and **should** also detail the remit and relationship with any relevant civil ATM requirements¹⁰. Any variance / delta between civil regulatory requirements and the MRP **should** be identified, subject to MAA Exemption / Waiver if necessary and promulgated as appropriate.

b. **Assurance.** Assurance of Civil Contracted ATM activities **should** be conducted by the MOD in close consultation with the appropriate civil aviation regulator¹¹.

6. **Aeronautical Information (AI).** AI is information resulting from the assembly, analysis and formatting of aeronautical data. AI products **should** be produced and assured by SQEP. Where contracts are in place for the provision of AI, the contract **should** be let against the requirements of RA 1005(1)⁹. HoE and ADH-Facing organizations **should** assure the ongoing accuracy of AI.

7. **UK Military Aeronautical Information Publications (UK Mil AIP).** ATM personnel **should** operate iaw the information contained within the UK Mil AIP unless the MRP directs otherwise. The military sponsors listed in the UK Mil AIP and HoE **should** assure the accuracy of the AI pertinent to their aviation activity and / or establishment that is published in the UK Mil AIP ▶ through effective management of their Defence Aerodrome Manual⁵. ◀

8. **UK Civil AIP.** Historically, information contained in CAP 032 UK Integrated AIP (UK IAIP¹²) was also duplicated in Military ATM Regulation. This duplication has now been removed and ATM personnel **should** operate iaw the information contained within the UK IAIP unless the MRP specifically directs otherwise▶◀.

Guidance Material 3201(1)

Military Air Traffic Management

9. **Royal Navy (RN) Books of Reference (BRds).** BRd 768 RN ATM & Assurance details the specific instructions, procedures and limitations which apply to RN ATM personnel employed in roles at shoreside RN units, or when embarked in Aviation-Capable RN or Royal Fleet Auxiliary Vessels, or those approved by Director Force Generation. This does not apply to RN Controllers employed at RAF Units / Stations who will operate to RAF ▶◀ Battlespace Management (▶◀BM) Orders.

10. **RAF ▶◀ BM Orders.** RAF ▶◀ BM Orders will apply to all units where RAF controllers provide ATS and where RAF Air Surveillance and Control System (ASACS) controllers provide ATS as part of an ASACS function¹³. ▶ This does not apply at RN Units / Stations where RAF controllers operate iaw RN BRds. ◀ Where ATM functions are provided under a MOD contract by a civil Air Navigation Service Provider (ANSP), Unit Orders will reflect the requirements of RAF ▶◀ BM Orders and any variances.

11. **Operational Orders.** Bespoke Military ATM Operational Orders may be issued for specific situations that are operationally necessary but will comply with RA 3201(1) or will be subject to extant Safety Management processes iaw RA 1020⁷ and RA 1200¹⁴.

12. **NATO STANAGS.** Where ATM-specific NATO STANAGs are utilized, the requirements of the activity will be detailed in Unit Orders¹⁵ and specific Exercise

⁸ eg Civil Aviation Authority (CAA)-licensed controllers, civilian aerodrome managers and civilian flight operations personnel.

⁹ Refer to RA 1005(1): General Principles.

¹⁰ eg CAA controller licensing requirements.

¹¹ eg CAA Safety and Regulation Group (SARG).

¹² The UK IAIP is maintained and published by the CAA and is made up of the UK Aeronautical Information Publication (AIP), AIP Supplements and Aeronautical Information Circulars (AICs).

¹³ eg ASACS-controlled Aircraft transits to segregated airspace and ASACS controllers serving as Air Traffic Control Officers at RAF(U) Swanwick.

¹⁴ Refer to RA 1200 – Air Safety Management.

¹⁵ NATO STANAGs are routinely applicable in the maritime tactical environment.

**Guidance
Material
3201(1)**

Instructions. Where STANAGs are implemented by the MRP 3000 Series regulations, this will be noted within the relevant RA.

13. **Airspace Management.** The CAA is the regulatory body responsible for the designation, classification and promulgation of airspace constructs within the UK.
- a. **DAATM.** The DAATM is a pan-Defence organization, which works directly for the RAF Assistant Chief of the Air Staff who is the senior responsible Crown Servant for MOD airspace issues and acts as a non-executive director on the CAA Board. The DAATM acts as the MOD representative organization, in close collaboration with the CAA, within Europe. The DAATM interacts with NATO, European Aviation Safety Agency (EASA) and the European Defence Agency to ensure that legislative developments regarding Airspace, ATM and Communication, Navigation and Surveillance requirements are known.
 - b. **Airspace Segregation.** The DAATM also manages the MOD's segregated airspace requirements and is responsible for the policy relating to the use of the UK Low Flying System. In conjunction with the CAA, the DAATM sets policy on the use of segregated airspace contained within CAP 740 UK Airspace Management Policy.
 - c. **ACP.** MOD organizations wishing to effect airspace changes (permanent, temporary and airspace trials) are ►to◄ contact DAATM for advice prior to initiating the process to undertake the ACP as set out within CAP 1616 Airspace ►Change.◄
14. **Civil Contracted ATM.** Where a variance requires a civil licensed Air Traffic Control Officer to control outside the privileges of their civil license, then approval will be sought, via the Air Safety Management System process, from the CAA and captured within Unit Orders. Assurance of civil contracted ANSPs will also be performed by the CAA iaw the requirements of the ANSP's Article 180 Approval.
15. **MOD AI Policy.** The MOD sets policy for AI in JSP 465 ►◄ Defence Geospatial Information Policy.
16. **UK Mil AIP.** The UK Mil AIP contains military-specific aeronautical planning information that is maintained and published by No1 Aeronautical Information Documents Unit.
17. **UK IAIP.** The military-specific AI contained within the UK IAIP will be compliant with the Standards and Recognised Practices (SARPS) of the International Civil Aviation Organization (ICAO) Annex 15, ICAO Doc 8126 and applicable NATO STANAGs unless clearly labelled to the contrary. The term 'For Military Users' is used throughout the UK IAIP to signify relevance to both military and / or civilian controllers who may be providing an ATS to UK military Air Systems.
18. **Health, Safety and Environmental Protection (HS&EP).** The MAA is the single independent regulatory body for all Defence aviation activity iaw MAA 01¹⁶. Notwithstanding the fact that the majority of provisions of the Air Navigation Order 2016 do not apply to military Aircraft, the Crown could be liable in common law if it were to operate its Aircraft negligently and cause injury or damage to property and individuals could be criminally liable if there are significant breaches of the obligations placed upon them. The Secretary of State for Defence HS&EP policy statement¹⁷ requires that: '►In circumstances where the nature of Defence and Security activities inevitably conflict with health and safety requirements and thus Defence has Derogations, Exemptions, or Dis-applications from HS&EP legislation, or where other circumstances indicate the need for Defence regulation of activities,◄ we maintain Departmental arrangements that produce outcomes that are, so far as reasonably practicable, at least as good as those required by UK legislation'.
19. **Civil Aviation Equivalence.** Although defence aviation activity is not beholden to the full requirements of civil aviation legislation and regulation, Military ATM will offer a level of safety that is at least as effective:

¹⁶ Refer to MAA 01: ►MAA◄ Regulatory Policy, Ch 1 paras 1-3 details more fully the MAA's Legal and Regulatory Framework.

¹⁷ ►Secretary of State Defence HS&EP Policy Statement revised April 2020.◄

**Guidance
Material
3201(1)**

a. **ICAO.** The Chicago Convention 1944 (CC), under which ICAO was created, separated civil and military aviation regulation. This separation is made clear in Article 3 of the CC which states that: 'the convention shall be applicable only to civil aircraft, and shall not be applicable to State aircraft'. The MOD has decided as a matter of policy to ensure that, wherever possible, its Aerodromes and their associated services will be designed and maintained iaw the ICAO SARPs.

20. **UK National Regulation.** When the UK was a member of the European Union some aviation law was made by the European Union and had direct legal effect, as a European Regulation, in the UK. The UK has now fully left the European Union, after the end of the UK / EU Agreement transitional period. From 1 January 2021 the UK law that applies to such aviation rights and obligations are the retained EU Regulations, as amended by various UK Statutory Instruments (made under the European Union (Withdrawal) Act 2018). The amendments that apply from 1 January 2021 do not fundamentally change any of those obligations or rights but deal only with the fact that the UK is no longer part of the EU legal system. Some EU aviation law was accompanied by Acceptable Means of Compliance (AMC), Guidance Material (GM), Certification Specifications (CS) or other information published by EASA. The CAA has adopted the version of AMC, GM, CSs and other information in force on 31 December 2020, as its policy with regard to compliance with the relevant UK law from 1 January 2021.

RA 3202 – Entitlement to provide Air Traffic Services, an Air Ground Communication Service (Military) or use Air Ground Radios and Air Traffic Management Equipment

Rationale

To ensure the safe provision of Air Traffic Services (ATS) or an Air Ground Communication Service (Military) (AGCS(Mil)) and the appropriate use of Air Ground Radios and Air Traffic Management (ATM) Equipment, Military and MOD Contracted civilian personnel will operate within the bounds of their entitlement. When services are applied incorrectly it can lead to the delivery of unsafe operations, increasing the Risk to Life in an Aviation Duty Holder (ADH) / Accountable Manager (Military Flying) (AM(MF)) operation. This Regulatory Article (RA) sets the requirements for personnel who provide an ATS, an AGCS(Mil), or who communicate with Aircraft using Air Ground Radios to ensure that they are appropriately qualified, trained, Competent and current to do so.

Contents

Definitions Relevant to this RA

3202(1): Qualifications and Entitlement to provide Air Traffic Services

3202(2): Controller Training

3202(3): Controller Periodicity of Assessment of Competence

3202(4): Controller Currency

3202(5): Qualifications, Training, Competence and Currency to provide an Air Ground Communication Service (Military)

3202(6): Training and Competence to transmit to Aircraft on Air Ground Radios

3202(7): Use of Air Traffic Management Equipment and Data

Definitions

Definitions Relevant to this RA

1. **Air Traffic Service.** Generic term meaning variously, Flight Information Service (FIS), Alerting service, Air Traffic advisory service¹, Air Traffic Control (ATC) service (Area Control Service, Approach Control Service or Aerodrome Control Service).
 - a. **FIS.** A service provided for the purpose of giving advice and information useful for the safe and efficient conduct of flights by means of radio signals to Aircraft. In the case of an Aerodrome, this also includes the granting or refusal of permission to Aircraft flying in or intending to fly within the Aerodrome Traffic Zone of that Aerodrome².
 - b. **Alerting Service.** A service provided to notify appropriate organizations regarding Aircraft in need of Search and Rescue aid and assist such organizations as required³.
 - c. **ATC Service.** A service provided for the purpose of preventing collisions between Aircraft (and, on the Manoeuvring Area between Aircraft and obstructions) and expediting and maintaining an orderly flow of Air Traffic².
2. **Air Ground Communication Service (Military) (AGCS(Mil))⁴.** A service provided to pilots at specific MOD Aerodromes. However, it is not viewed as an ATS because it does not include an Alerting service as part of its content. For the purposes of this RA, the term AGCS(Mil) is used to distinguish it from a civilian provided AGCS⁵. Whilst both provide an equivalent level of service, the AGCS(Mil) is provided in support of military tasks.

¹ An Air Traffic advisory service is a service provided within Class F airspace which is not currently established in the UK.

² Refer to the Air Navigation Order 2016.

³ Refer to Civil Aviation Publication (CAP) 493 – Manual of Air Traffic Services – Part 1.

⁴ The Term Military Air Ground Communication Service (MAGCS) is also acceptable.

⁵ For clarity, throughout this RA the term AGCS(Civ) will hereafter be used to indicate an AGCS in support of civilian flying operations, the provision of which is regulated by the CAA.

Regulation 3202(1)

Qualifications and Entitlement to provide Air Traffic Services

3202(1) In order to provide an ATS, Controllers **shall** be qualified and in possession of an applicable Certificate of Competence (CofC)⁶, ATC Officer (ATCO) or FIS Officer (FISO) Licence.

Acceptable Means of Compliance 3202(1)

Qualifications and Entitlement to provide Air Traffic Services

3. An ATS **should** only be provided by those personnel who have attended and passed the appropriate course for their role, as defined by the relevant Front Line Command (FLC) / MOD contract authority⁷, at a UK Defence / Civil Aviation Authority (CAA) accredited training facility and have been awarded an appropriate CofC, ATCO Licence or FISO Licence.

4. The CofC / Licence **should** be documented with each subsequent control endorsement and qualification gained. It **should** include training ratings where applicable.

5. The CofC / Licence **should** contain a medical certificate⁸.

6. A ► **Special Use Airspace** ◀ Crossing Service ► **(SUACS)** ◀ **should** only be provided by an ATCO at the nominated service unit as detailed in the UK Aeronautical Information Publication (AIP)⁹.

7. A ► **Special Use Airspace** ◀ Activity Information Service ► **(SUA AIS)** ◀ **should** only be provided by an ATCO or FISO at the nominated service unit detailed in the UK AIP⁹.

Guidance Material 3202(1)

Qualifications and Entitlement to provide Air Traffic Services

8. The nominated ► **SUACS** ◀ Unit will, when the Danger Area activity permits, provide a clearance for an Aircraft to cross the Danger Area under a suitable type of service¹⁰.

9. A ► **SUA AIS** ◀ enables pilots to obtain, via a nominated service unit an airborne update of the activity status of a participating Danger Area whose position is relevant to the flight of the Aircraft. The service can only provide information on the activity status of a Danger Area and cannot provide a clearance to cross that Danger Area, whether it is active or not¹⁰.

Regulation 3202(2)

Controller Training

3202(2) Controllers **shall** be appropriately trained.

Acceptable Means of Compliance 3202(2)

Controller Training

10. FLCs / MOD contract authorities⁷ **should** issue orders / instructions detailing the unit training scheme for each role within their Area of Responsibility (AoR) in relation to ATS provision.

Guidance Material 3202(2)

Controller Training

11. Nil.

Regulation 3202(3)

Controller Periodicity of Assessment of Competence

3202(3) Controller Competence **shall** be periodically assessed.

⁶ Refer to MAA02: MAA Master Glossary.

⁷ In the context of this RA 'contract authority' refers to a non-military organization contracted to deliver or support military aviation activity.

⁸ Refer to RA 3203 – Military and MOD Contracted Civilian Controller Medical Requirements.

⁹ Refer to UK Aeronautical Information Publication (AIP) ENR 5.1.

¹⁰ Refer to UK AIP ENR 1.1.

**Acceptable
Means of
Compliance
3202(3)**

Controller Periodicity of Assessment of Competence

12. A continuous rolling assessment process **should** be activated from the initial award of an operating endorsement to demonstrate continued Competence.
13. FLCs / MOD contract authorities⁷ **should** stipulate in orders / instructions the periodicity and scope of Controller assessment and, where applicable, assessment for additional qualifications held.
14. All evidence of such activity **should** be recorded.

**Guidance
Material
3202(3)**

Controller Periodicity of Assessment of Competence

15. Recording of assessment may be in the CofC and / or another suitable database as determined by the FLC / MOD contract authority⁷.

**Regulation
3202(4)**

Controller Currency

- 3202(4) Controllers **shall** maintain currency.

**Acceptable
Means of
Compliance
3202(4)**

Controller Currency

16. All personnel involved in controlling duties **should** maintain currency for each endorsement held and, where applicable, additional qualifications held.
17. FLCs / MOD contract authorities⁷ **should** stipulate in orders / instructions the currency requirements for each discipline within their AoR. The process for regaining currency where it has lapsed **should** also be stipulated.

**Guidance
Material
3202(4)**

Controller Currency

18. Nil.

**Regulation
3202(5)**

Qualifications, Training, Competence and Currency to provide an Air Ground Communication Service (Military)

- 3202(5) Personnel providing an AGCS(Mil) **shall** be appropriately qualified, trained, current and have their Competence periodically assessed.

**Acceptable
Means of
Compliance
3202(5)**

Qualifications, Training, Competence and Currency to provide an Air Ground Communication Service (Military)

19. An AGCS(Mil), **should** only be provided by those personnel who have attended and passed the appropriate course for their role, as defined by the relevant FLC, and have been awarded a Radio Operator's Certificate of Competence (Military) (ROCC(Mil))¹¹.
20. FLCs / MOD contract authorities⁷ **should** issue orders / instructions detailing how an AGCS(Mil) will be provided within their AoR, and the associated training requirements.
21. A continuous rolling assessment process **should** be activated from the initial award of a ROCC(Mil) to demonstrate continued Competence.
22. FLCs / MOD contract authorities⁷ **should** issue orders / instructions detailing the periodicity and scope of Competency assessments and the currency requirements for the provision of AGCS(Mil) within their AoR. The process for regaining currency where it has lapsed **should** also be stipulated. All evidence of such activity **should** be recorded.

¹¹ The term Military Air Ground Radio Operator's Certificate of Competence (MAGROCC) is also acceptable.

Acceptable Means of Compliance 3202(5)

23. There is considerable difference between the provision of ATS and AGCS(Mil). Therefore:
- When providing an AGCS(Mil), personnel **should** ensure that they do not pass a message which could be construed to be the provision of ATS.
 - ATS qualifications do not entitle the holder to provide an AGCS(Mil). Qualified ATS personnel who are invited by an MOD establishment to provide an AGCS(Mil)¹², at events such as an air show or air power demonstration, **should** only do so if they hold a ROCC(Mil).
 - Qualified ATS personnel **should** be particularly vigilant in the application of an AGCS(Mil), to ensure they do not lapse into giving an ATS or any part thereof, a FIS, or any implied control.
24. AGCS(Mil) phraseology **should** be consistent with the AGCS(Civ) phraseology in CAP 413¹³.
25. Personnel providing an AGCS(Mil) **should** ensure that the full call sign, including the suffix 'RADIO', is used in response to the initial call from an Aircraft and on any other occasion where there may be doubt about the service being provided.

Guidance Material 3202(5)

Qualifications, Training, Competence and Currency to provide an Air Ground Communication Service (Military)

26. The ROCC(Mil) is a military equivalent of the civilian ROCC. FLCs wishing to provide an AGCS(Mil) will need to establish the means to implement the training and examination required to issue a ROCC(Mil), and an appropriate Assurance regime to enable compliance with this RA¹⁴.
27. When in receipt of an AGCS(Mil), pilots operating on and in the vicinity of the Aerodrome are provided with traffic and weather information. Such traffic information is based primarily on reports made by other pilots and whilst it may be used to assist a pilot in making a decision, the safe conduct of the flight remains the pilot's Responsibility.
28. ATS qualifications do not entitle the holder to provide an AGCS(Civ). Qualified ATS personnel who are invited by civil Aerodrome authorities to provide an AGCS(Civ)¹², at events such as an air show or air power demonstration, will be expected to hold or obtain a civilian ROCC issued by CAA Safety and Airspace Regulation Group (SARG).
29. If an AGCS(Civ) is required in support of civilian activity¹⁵ at an MOD establishment, it will be regulated by the CAA and therefore falls outside the remit of MAA Regulation. In such circumstances, a civilian ROCC must be obtained from CAA SARG, and the AGCS provided in accordance with (iaw) CAP 452¹⁶.
30. Any holder of an ATC CofC issued to a member of His Majesty's Forces with a current unit validation may apply directly to the UK CAA for a civilian ROCC, by completing a Safety Regulation Group (SRG) 1413 application form¹⁶, without having to take the written or practical examinations.

Regulation 3202(6)

Training and Competence to transmit to Aircraft on Air Ground Radios

- 3202(6) Personnel transmitting to Aircraft on Air Ground Radios for the purpose of assisting the pilot(s) with the safe conduct of flight other than the provisions of RA 3202(1) or RA 3202(5),

¹² Note that this is separate to the role of a Flying Display Director (FDD) which is covered in RA 2335 – Flying Displays, Display Flying, Role Demonstrations and Flypasts.

¹³ Refer to CAP 413: UK Radiotelephony Manual.

¹⁴ The ROCC(Mil) is currently only available within RAF 22Gp. FLCs wishing to establish a ROCC(Mil) may wish to liaise accordingly to benefit from their experience.

¹⁵ For example, a civilian flying club using the Aerodrome at the weekend.

¹⁶ Refer to CAP 452: Aeronautical Radio Station Operator's Guide.

**Regulation
3202(6)**

shall be appropriately trained and have their Competence periodically assessed.

**Acceptable
Means of
Compliance
3202(6)**

Training and Competence to transmit to Aircraft on Air Ground Radios

31. FLCs / MOD contract authorities⁷ **should** issue orders / instructions detailing the training requirements for roles within their AoR that transmit to Aircraft on Air to Ground radios for the purpose of assisting the pilot with the safe conduct of the flight.
32. A continuous rolling assessment process **should** be activated to demonstrate continued Competence.
33. FLCs / MOD contract authorities⁷ **should** stipulate in orders / instructions the periodicity of Competency assessments for personnel that transmit to Aircraft on Air Ground Radios for the purpose of assisting the pilot with the safe conduct of flight. These assessments **should** include checks for Competence and radiotelephony standards.
34. All training and Competency assessments **should** be recorded.
35. When Air to Ground Radios are being used for purposes other than the provision of an ATS or AGCS, FLCs / MOD contract authorities⁷ **should** issue orders / instructions to ensure that their use, for transmissions, does not inadvertently constitute the provision of an ATS or AGCS. Details on the phraseology to be employed **should** be included.
36. Training and Competency assessments for transmitting to Aircraft on Air Ground Radios **should not** be applied to qualified and current Aircrew or personnel who are qualified iaw RA 3202(1) or RA 3202(5). These personnel are authorized to transmit to Aircraft on Air Ground Radios by virtue of their already existing qualifications.

**Guidance
Material
3202(6)**

Training and Competence to transmit to Aircraft on Air Ground Radios

37. Where Air to Ground Radios are used to provided information to pilots and mission crews that is not related to the safe conduct of flight, this is outside the scope of this RA.
38. Nothing in this RA prevents any person from transmitting to an Aircraft on an Air Ground Radio for the purpose of avoiding immediate danger.

**Regulation
3202(7)**

Use of Air Traffic Management Equipment and Data

3202(7) ATM Equipment and data¹⁷ **shall** only be used by personnel who are appropriately qualified, trained and assessed as Competent to do so.

**Acceptable
Means of
Compliance
3202(7)**

Use of Air Traffic Management Equipment and Data

39. ATM Equipment and data **should** only be used for the provision of ATS by personnel who are qualified iaw RA 3202(1).
40. FLCs / MOD contract authorities⁷ **should** issue orders / instructions to ensure that the use of ATM Equipment and data by personnel not qualified iaw RA 3202(1), does not inadvertently constitute the provision of an ATS, including consideration of any phraseology to be employed.
41. FLCs / MOD contract authorities⁷ **should** issue orders / instructions detailing the training requirements for all roles within their AoR that are required to use ATM Equipment and data.

¹⁷ In the context of this RA, ATM Equipment and data refers to equipment and / or data whose primary purpose is the provision of ATS.

**Guidance
Material
3202(7)**

Use of Air Traffic Management Equipment and Data

42. Nil.

► This RA has been substantially rewritten; for clarity no charge marks are presented – please read RA in its entirety ◀

RA 3203 – Military and MOD Contracted Civilian Controller Medical Requirements

Rationale

Controllers^{1,2} provide Air Traffic Services (ATS) to support the safe operation of Aircraft. A Controller who is not medically fit to perform their duty presents a Risk of providing an unsafe ATS provision to Aircrew. Controllers are therefore required to be physically and mentally fit to carry out their duties as defined in Air Publication (AP) 1269A³.

Contents

- 3203(1): Controller Medical Certificate
- 3203(2): Controller Fitness-to-Control
- 3203(3): Controller Operations – Upper Age Restrictions
- 3203(4): Temporary Medical Restrictions to Controlling Duties
- 3203(5): Blood Donation and Controlling Duties

Regulation 3203(1)

Controller Medical Certificate

3203(1) Controllers **shall** hold an appropriate medical certificate.

Acceptable Means of Compliance 3203(1)

Controller Medical Certificate

1. Where AP 1269A³ refers to Aircrew, unless stated otherwise, this **should** also be taken to refer to Controllers.
2. Aviation Duty Holders (ADH) and Heads of Establishment (HoE) **should** ensure that all Controllers within their Area of Responsibility (AoR) hold an appropriate and valid Joint Medical Employment Standard (JMES). The ADH and HoE **should** ensure access to a Military Aviation Medical Examiner (MAME) is available, with advice sought from the Command Flight Medical Officer (CFMO (RAF))⁴ if required.

Military Controllers⁵

3. Military Controllers **should** be certified medically fit in the first instance through an initial medical examination by the Recruitment and Selection Department of Occupational Medicine (R&S DOM).
4. Thereafter, Military Controllers in a controlling appointment **should** be certified medically fit by a MAME, periodically⁶ as follows:
 - a. Military Controllers under Service Primary Care **should** attend a Periodic Medical Examination (PME) by a MAME.
 - b. Military Controllers not under Service Primary Care **should**:
 - (1) Ensure a completed Medical Attendant Report (MAR) and Statement of Health (SoH) are provided to the MAME when attending a PME or;
 - (2) Present a completed MAR, SoH and certified copy of a Class 3 medical certificate to the MAME when applying for a medical waiver.

¹ Refer to MAA02: MAA Master Glossary.

² This includes Air Traffic Controllers, Weapons Controllers, civilian licensed Air Traffic Controllers operating at MOD Aerodromes, but excludes Identification Officers, Truck Runway Control Controllers, and Joint Terminal Attack Controllers (JTACs) operating to JSP 918, JTAC Policy.

³ Refer to AP 1269A – Assessment of Medical Fitness, aviation medical policy which is applicable to all Service personnel.

⁴ Or single Service equivalent.

⁵ This includes: regular military personnel as defined by Section 374 of the [Armed Forces Act 2006](#), Full Time Reserve Service (FTRS) Controllers, legacy Civil Service Aviation Officer (AVO) Controllers and MOD reserve forces Controllers (Royal Fleet Reserve, the Royal Naval Reserve, the Royal Marines Reserve, the Army Reserve, the Territorial Army, the Royal Air Force Reserve or the Royal Auxiliary Air Force).

⁶ Refer to AP 1269A – Assessment of Medical Fitness – Leaflet 4-02: Royal Air Force Medical Standards – Aircrew.

**Acceptable
Means of
Compliance
3203(1)**

5. For Military Controllers in non-controlling appointments the PME can be deferred. In these circumstances, Controllers **should** refer to AP 1269A⁶ for details on PME renewal timelines.

MOD Contracted Civilian Controllers

6. MOD Contracted Civilian Controllers **should** hold a valid UK Civil Aviation Authority (CAA) / European Aviation Safety Agency (EASA) Class 3 medical certificate and **should** comply with the requirements of Civil Aviation Publication (CAP) 1251⁷.

7. NATS Controllers **should** hold a UK CAA / EASA Class 3 Air Traffic Control Officer (ATCO) medical certificate awarded by a NATS Civilian Aviation Medical Examiner (AME), endorsed as MAMEs by Deputy Assistant Chief of Staff Aviation Medicine (DACoS Av Med), RAF Centre of Aviation Medicine (CAM) and comply with the requirements of (CAP) 1251⁷.

8. For all MOD Contracted Civilian Controllers, initial certification of fitness for military controlling duties is made by R&S DOM⁸. The MAME **should** submit the valid UK CAA / EASA Class 3 medical certificate, supported by a MAR and SoH (not required if the Controller is under Service Primary Care) to R&S DOM to allow an initial award of a JMES and military oversight of medical fitness.

Note:

MOD Contracted Civilian Controllers can use designated Civilian AMEs in place of a MAME⁹.

9. For renewal certification, the MOD Contracted Civilian Controller **should**:

- a. Ensure a completed MAR and SoH are provided to the MAME¹⁰ when attending a PME or;
- b. Present a completed MAR, SoH (not required if the Controller is under Service Primary Care) and a certified copy of a Class 3 medical certificate when applying for a medical waiver, in accordance with (iaw) AP 1269A⁶.

Military and MOD Contracted Civilian Controllers

10. Controllers **should** have an electrocardiogram (ECG) as detailed in AP 1269A⁶.

11. The certification of medical fitness **should** be entered in the Controller Certificate of Competency (CofC) or equivalent documentation and signed and dated by a MAME¹⁰.

12. Military Controllers **should** comply with all medical restrictions (permanent or temporary) as noted in their CofC, or equivalent documentation.

13. MOD Contracted Civilian Controllers **should** comply with all medical restrictions (permanent or temporary) as noted in their licence.

14. Controllers required to provide a MAR **should** ensure it is:

- a. Completed by their Civilian General Practitioner.
- b. Available to the certifying MAME.
- c. Dated within 2 months of the medical certificate due date.

15. Controllers **should** ensure that their medical certificate remains valid.

**Guidance
Material
3203(1)**

Controller Medical Certificate

16. The elements of a JMES are described in AP 1269A¹¹.

⁷ Refer to CAP 1251 – Air Traffic Controllers - Licensing.

⁸ R&S DOM, Adastral Hall, PO Box 1000, RAFC Cranwell, Sleaford, Lincolnshire, NG34 8GZ.

⁹ Details of available MAMEs / Civilian AMEs are available via CFMO (RAF), AIR_COS_Spt-CAM-CFMOSO1@mod.gov.uk. Civilian AMEs require endorsement by DACoS AvMed, at RAF CAM before they can be substituted for a MAME.

¹⁰ Or a Civilian AME iaw paragraph 8 Note.

¹¹ Refer to AP 1269A - Assessment of Medical Fitness – Leaflet 1-01: Method of Recording Medical Fitness in the Royal Air Force.

**Guidance
Material
3203(1)**

17. PME are valid until the last day of the month in which the next PME is due, except Royal Navy Controllers who are to have their PME completed by the anniversary of their previous PME.
18. A MAME is a Medical Officer (MO), a Civilian Medical Practitioner (CMP) or a locum doctor, qualified to assess and determine fitness for Aircrew and Controllers. A MAME must complete approved training from RAF CAM Aviation Medicine Training Wing and be endorsed by the single Service medical authority.
19. A MAR and SoH are designed to provide information to a MAME to enable a full assessment of a Controller's fitness for their role. Full details of a MAR and SoH can be found in AP 1269A¹².
20. Definitive medical guidelines and instructions for assessment of medical fitness standards are published in AP 1269A and may be augmented in single-Service orders and other documents.
21. For MOD Contracted Civilian Controllers, the JMES will normally correspond to the class of civilian medical certificate required of their controlling role iaw CAP 1251⁷.

**Regulation
3203(2)**

Controller Fitness-to-Control

- 3203(2) Controllers **shall** be fit-to-control. Controllers uncertain of their fitness-to-control **shall** report to a MAME¹⁰ before commencing controlling duties.

**Acceptable
Means of
Compliance
3203(2)**

Controller Fitness-to-Control

22. A Supervisor / ATCO in charge who has reason to doubt the medical fitness of any Controller presenting themselves for duty **should** seek the advice of a MAME¹⁰.
23. All Controllers **should**:
- Seek medical advice if they have any reason to doubt their fitness-to-control, even for a relatively minor illness.
 - Contact a MAME¹⁰ prior to returning to controlling duties if another medical practitioner (not qualified or endorsed as a MAME) has been consulted.
 - Report any period when they are unfit to control, or have specific limitations applied to their controlling status, to their Supervisor.
24. If a Controller is declared unfit-to-control (JMES Code 2100 – Unfit controlling duties) by a MO / CMP, the MO / CMP **should** record it in the Controller's Health Records¹³.
25. MOs / CMPs **should** ensure that the command chain is informed of any change in medical fitness affecting the controlling status of their Controllers.
26. When declared unfit, Controllers **should** ascertain whether they require a review by a MAME¹⁰ before returning to controlling duties; if this is required, the Controller is responsible for ensuring that such a review is obtained.
27. MOD Contracted Civilian Controllers **should** follow the medical specification in CAP 1251⁷, UK (EU) 2015/340¹⁴ and the CAA guide on medical certification of Air Traffic Controllers¹⁵. Where there is a requirement for notifying the CAA, a MAME¹⁰ **should** also be informed.

¹² Refer to AP 1269A – Assessment of Medical Fitness, Leaflet 4-02: Royal Air Force Medical Standards – Aircrew, Annexes C and D.

¹³ For service personnel, all integrated Electronic Health Record (iEHR)s are managed through the Defence Medical Information Capability Programme (DMICP) which links to JMES data on the MOD's Joint Personnel Administration (JPA) system.

¹⁴ Refer to UK (EU) 2015/340 – Air Traffic Controllers Licensing and Certification.

¹⁵ The CAA Guide to Medical Certification for Air Traffic Controllers can be found on the CAA website

<https://www.caa.co.uk/commercial-industry/airspace/air-traffic-management-and-air-navigational-services/licences/medical-requirements/>.

**Guidance
Material
3203(2)**

Controller Fitness-to-Control

28. Controllers may declare that they do not feel fit-to-control, without seeking prior medical advice.
29. Where this RA states that Controllers consult a MAME¹⁰, contact by telephone may be appropriate, eg to discuss a return to controlling duties following a prescribed course of medication.

**Regulation
3203(3)**

Controller Operations – Upper Age Restrictions

- 3203(3) Controllers over the age of 60 **shall** have a stress ECG on alternate years and annually for those aged 65 and over.

**Acceptable
Means of
Compliance
3203(3)**

Controller Operations – Upper Age Restrictions

30. Controllers unable to achieve a satisfactory stress ECG result or pending further investigation **should not** control unless there is another suitably qualified Controller present who does not hold the JMES Code 2101, refer to paragraph 34.

**Guidance
Material
3203(3)**

Controller Operations – Upper Age Restrictions

31. Nil.

**Regulation
3203(4)**

Temporary Medical Restrictions to Controlling Duties

- 3203(4) Controllers **shall** comply with any restrictions placed upon them following exposure to conditions affecting their fitness-to-control.

**Acceptable
Means of
Compliance
3203(4)**

Temporary Medical Restrictions to Controlling Duties

32. Controllers **should not**:
- a. Take any prescription medicines, drugs, tablets, remedies or nicotine replacement therapy before reporting for controlling duties, unless they have been prescribed or approved by a MAME¹⁰.
 - b. Use any over the counter medicines, drugs, tablets or remedies within 24 hours of reporting for controlling duties unless approved by a MAME¹⁰, as the effect on an individual's fitness-to-control may not be immediately apparent.
 - c. Use any dietary supplements, homeopathic remedies or alternative medicines unless approved by a MAME¹⁰.
33. Temporary medical restrictions to controlling duties **should** be placed on Controllers who have been exposed to conditions which may affect their ability to control. If a Controller has specific limitations applied by an MO / CMP, the MO / CMP **should** record it in the Controller's Health Records¹³.
34. Military Controllers who are fit to control only when another qualified Military Controller is on duty and in close proximity **should** be awarded a JMES Code 2101. There is no civilian equivalent to JMES Code 2101 and this **should not** be applied to MOD contracted civilian Controllers.
35. MOs / CMPs **should** ensure that the command chain is informed when any of their Controllers are awarded the JMES Code 2101.
36. Controllers **should** seek approval from a MAME¹⁰ (or medical practitioner in consultation with a MAME¹⁰) prior to undergoing:
- a. **Elective Surgical Procedures.**

**Acceptable
Means of
Compliance
3203(4)**

- b. **Laser Eye Surgery.** Controllers contemplating Corneal Refractive Surgery (CRS) for visual correction **should** consult their MAME¹⁰ for onward referral to the Defence Consultant Advisor Ophthalmology¹⁶ for assessment.
- c. **Inoculations and Vaccinations.** Controllers **should** ascertain from a MAME¹⁰ the duration of any controlling restrictions following inoculations or vaccination. Most inoculations and vaccinations will restrict controlling, normally for at least 12 hours.
- d. **Hypnotherapy / Hypnosis.**
- e. **Acupuncture.** Controllers **should** be precluded from controlling duties for 12 hours following each treatment.
- f. **Complementary and Alternative Medicine.**
37. **Anaesthetics.** Controllers **should not** undertake controlling duties for:
- a. 7 days following a general, spinal or epidural anaesthetic.
- b. 48 hours following drug-induced sedation except when a sedative drug has been provided iaw the policy for the Management of Work and Rest in Aircrew, which **should** also be taken to refer to Controllers¹⁷.
- c. 12 hours after a local or regional dental anaesthetic.
- d. The periods specified in paragraph 37a – c may be extended at the discretion of a Medical or Dental Officer.
38. **Eye Examination.** Examination by an eye specialist may include the application of mydriatic agents, usually eye drops. Controllers **should not** control for 24 hours after the application of mydriatics. In the case of atropine, the period **should** be 14 days.
39. **Bone Marrow Donation / Stem Cell Harvesting.** Controllers **should not** control for a minimum of 7 days after the donation of bone marrow or stem cell harvesting. Prior to returning to controlling duties a MAME¹⁰ **should** be consulted.
40. **Boxing.** Controllers who have participated in a boxing bout (including sparring, but excluding non-contact training) **should not** control for 48 hours after a bout. Furthermore, they **should** be examined by a MAME¹⁰ before resuming controlling duties.
41. MOD Contracted Civilian Controllers **should** follow CAP 1251⁷ and UK (EU) 2015/340¹⁴ when required to declare provisional inability. Where there is a medical requirement for notifying the CAA, a MAME¹⁰ **should** also be informed.

**Guidance
Material
3203(4)**

Temporary Medical Restrictions to Controlling Duties

42. Comparative military policy can be found at AP 1269A Section 5¹⁸, and JSP 950¹⁹.
43. The effect on an individual's fitness to control may not be immediately apparent if medicines, drugs, tablets, dietary supplements, homeopathic remedies or alternative medicines are taken. Positive and pro-active engagement with a MAME¹⁰ can provide an efficient mechanism to ensure fitness-to-control is maintained.
44. **Hypnotherapy / Hypnosis.** Some of the stress relaxation techniques used in hypnotherapy / hypnosis may have a prolonged adverse effect on the controlling task. Specialist advice is also to be sought via the MAME from a security officer to assess the status of the individual's security clearance.
45. **Complementary and Alternative Medicine.** Some techniques used by complementary or alternative medical practitioners are not currently subject to the same controls as conventional medicine and may not be evidence based.

¹⁶ Refer to AP 1269A – Assessment of Medical Fitness – Leaflet 5-14: Ophthalmology. This leaflet is the authoritative ophthalmology policy document for all UK Military Controllers.

¹⁷ Refer to AP 1269A, Assessment of Medical Fitness – Leaflet 5-19 Drugs for Aircrew and Controllers.

¹⁸ Refer to AP 1269A, Assessment of Medical Fitness – Section 5 – Clinical Effect on Employment.

¹⁹ Refer to JSP 950 – Medical Policy.

**Guidance
Material
3203(4)**

Complementary or alternative medicine may have side-effects detrimental to aviation Safety.

46. A wide variety of sporting activities could lead to a risk of concussion. Where there is any risk that a head injury may have been incurred, consultation with a MAME¹⁰ is likely to be necessary.

47. Further details of when holders of Class 3 medical certificates are required to seek aero-medical advice are contained within UK (EU) 2015/340¹⁴ and CAP 1251⁷.

**Regulation
3203(5)****Blood Donation and Controlling Duties**

3203(5) Restrictions **shall** be placed upon Controllers after donating blood.

**Acceptable
Means of
Compliance
3203(5)****Blood Donation and Controlling Duties**

48. Controllers **should not** control until 12 hours have elapsed after donating blood.

**Guidance
Material
3203(5)****Blood Donation and Controlling Duties**

49. Nil.

RA 3204 - Air Traffic Management Records

Rationale Documents pertaining to the provision of Air Traffic Management (ATM) are required to provide accurate records of activity. They supply essential knowledge to personnel who operate and supervise ATM. Accurate records are required ► *for the management of personnel and equipment, and* ◀ allow analysis and exploitation of data to improve Air Safety.

Contents

3204(1): Air Traffic Management Records

Regulation 3204(1)

Air Traffic Management Records

3204(1) Heads of Establishment (HoE) and Aviation Duty Holder (ADH)-Facing Organizations **shall** ensure accurate ATM records are maintained.

Acceptable Means of Compliance 3204(1)

Air Traffic Management Records

1. ATM staff **should** maintain a watch log, a movements log and other logs as detailed by Front Line Commands (FLC).
2. ► **Aircraft** ◀ **Movement Log**. RAF Form 68¹ **should** be used for recording ► **Aircraft** ◀ movements.
3. **Other Log Books / Records**. Other log books / records **should** be maintained in accordance with (iaw) FLC requirements or as detailed in Local / Unit Orders.
4. Where written records are maintained, they **should** be retained as follows:
 - a. RAF Forms 68 and 6658² **should** be retained on unit for a period of 6 years after their completion and **should** then ► ◀ be forwarded to the MOD archive. RN Log Books **should** be archived in the Royal Naval Historic Branch at HMS Nelson, Portsmouth.
 - b. **Other Log Books / Records**. Other log books / records **should** be maintained iaw single-Service policy.
 - c. **Radar, Telephone and Audio Recordings**. Radar, telephone and audio recordings **should** be retained iaw DefStan 00-972³.
5. Where electronic records are maintained, they **should** be retained in line with written records as detailed in para 4.
6. **Lower Airspace Radar Services (LARS) Records**. LARS ATS Units **should** collate monthly records as follows:
 - a. The number of Civil and Military ► **Aircraft** ◀ provided with a UK Flight Information Service ([UK FIS](#)) ► ◀⁴ broken down by type of UK FIS.
 - b. The number of occasions they refuse individual ► **Aircraft** ◀ a LARS (on a daily reporting basis).
 - c. The amount of time LARS is unavailable due to, for example, equipment

¹ Royal Navy (RN) Air Traffic Service (ATS) providers **should** use the ► **MODNet** ◀--based RN Station Flypro iaw BRd 767 Naval Aviation Order (NAO) 3204(1) or suitable electronic means.

² Air Traffic Control (ATC) Watch Log.

³ DefStan 00-972: Military Air Traffic Services Equipment Safety and Performance Standards (Aerodrome, Terminal and Naval Air Traffic Services)

⁴ ► **Refer to RA 3224 –UK Flight Information Services.** ◀

**Acceptable
Means of
Compliance
3204(1)**

unserviceabilities or shortage of capacity.

- d. Any further records required and detailed by FLC.
- e. Records **should** be forwarded to:
 - (1) FLCs as defined and required in orders.
 - (2) Civil Aviation Authority Airspace Regulation, Safety and Airspace Regulation Group, on a monthly basis.

**Guidance
Material
3204(1)****Air Traffic Management Records**

- 7. **ATC Watch Log (RAF Form 6658⁵)**. A single ATC Watch Log will be maintained in order to provide a formal record of ATM related events. All entries will be made in ink and in chronological order. No erasures will be made to the log and under no circumstances will pages be removed from the log book.

⁵ This document is used by both RAF and RN providers as well as Aerodromes operating under a military contract.

RA 3205 - Radar Analysis Cell

Rationale

The MOD is required to provide services that support the Joint and Integrated approach to Air Traffic Management in the UK Flight Information Regions. The provision of radar analysis and replay services allows effective safety investigation of occurrences in civil and military flying activity and contributes to minimizing the Aviation Risk to Life.

Contents

3205(1): Radar Analysis Cell

Regulation 3205(1)

Radar Analysis Cell

3205(1) The MOD **shall** provide a Radar Analysis Cell (RAC).

Acceptable Means of Compliance 3205(1)

Radar Analysis Cell

1. The RAC **should**:
 - a. Provide the UK AIRPROX Board with detailed radar analysis and radar replay recordings and carry out tracing action of Air Systems involved in AIRPROX in the UK.
 - b. Provide detailed radar analysis, radar replay recordings of incidents and assistance with tracing action to assist the Defence Flying Complaints Investigation Team **▶and◀** Police and Security Services (UK) in their investigations of breaches of regulations and suspicious activity.
 - c. Provide the Defence Accident Investigation Branch (Air) with detailed radar analysis and radar recordings.
 - d. Assist with tracing action in connection with Air Systems involved in Air Traffic Control Occurrence Reports and other tasks as directed by HQ Air **▶SO2 BM Safety A5◀**, including provision of detailed radar analysis and radar replay recordings.
 - e. Undertake other tracing action in accordance with Civil Air Publication (CAP) 493 Manual of Air Traffic Services Part 1.

Guidance Material 3205(1)

Radar Analysis Cell

2. Nil.

Intentionally Blank for Print Pagination

RA 3206 - Air Traffic Management Equipment Checks

Rationale *Modern Maintenance philosophy for electronic equipment calls for the minimum of preventive Maintenance. Functional checks of Communications-Electronic installations in Air Traffic Control towers and Centres are required and unserviceabilities reported and rectified.*

Contents **3206(1): Air Traffic Management Equipment Checks**

Regulation **Air Traffic Management Equipment Checks**

3206(1)

3206(1) Units **shall** ensure specified checks are undertaken on Air Traffic Management (ATM) Equipment.

**Acceptable
Means of
Compliance
3206(1)**

Air Traffic Management Equipment Checks

1. Only ►a◄ Suitably Qualified and Experience ►Person◄ **should** undertake ATM Equipment checks.
2. ATM equipment checks **should** be undertaken at the required periodicity as laid down in the publication applicable to that equipment. Units **should** ensure that the appropriate ATM equipment documentation is available.
3. Any unserviceability **should** be recorded in the appropriate ATM Record and reported as soon as practicable to the appropriate Maintenance organization in accordance with Local / Unit Orders.
4. Information on unserviceable ATM equipment **should** be promulgated in accordance with RA 1026¹◄ or as defined in Local / Unit Orders.

**Guidance
Material
3206(1)**

Air Traffic Management Equipment Checks

5. Nil.

¹ ►Refer to RA 1026 – Aerodrome Operator and Aerodrome Supervisor (Recreational Flying) Roles and Responsibilities including Aerodrome and Helicopter Landing Site Assurance Requirements.◄

Intentionally Blank for Print Pagination

RA 3207 - Controller Fatigue Management

Rationale

Fatigue is an experience of physical or mental weariness that results in reduced alertness and can be a significant factor in degrading the performance of ► a Controller¹. A Controller suffering from fatigue may not be fit to perform their duty and presents a risk of unsafe service provision. ◀ The Hazards associated with fatigue need to be identified, analyzed and managed to minimize any contribution to Aviation Risk to Life (RtL) and to optimize staff performance.

Contents

3207(1): Controller Fatigue Management

Regulation 3207(1)

Controller Fatigue Management

3207(1) Heads of Establishments (HoEs) and Aviation Duty Holder (ADH)-Facing Organizations² **shall** manage Controller Fatigue Management (FM) processes within their Area of Responsibility.

Acceptable Means of Compliance 3207(1)

Controller Fatigue Management

1. **Controller FM System.** HoEs and ADH-Facing Organizations **should** implement a Controller FM System to provide assurance that the impact of fatigue on controllers is fully understood by individuals and managed by supervisors of controllers to minimize the negative effects on performance.
2. The Controller FM System **should** consider, but is not limited to, the following factors:
 - a. The physical work environment eg: extremes of noise, light, temperature and other distractors.
 - b. Rest facilities.
 - c. Periodicity of shift cycles.
 - d. Length of shifts.
 - e. Night working.
 - f. Number of rest days.
 - g. Periodicity and duration of rest periods.
 - h. Sleep cycles.
 - i. Sleep quality.
 - j. Additional duties conducted outside of the primary controlling task.
 - k. Stressful events encountered at work and at home.
3. **Risk Management (RM).** The RM processes outlined in RA 1200³, RA 1210⁴ and the Manual of Air Safety⁵ **should** be considered when managing fatigue-related Hazards and identifying any potential impact on RtL.
4. **Controller FM Interfaces.** Controller FM processes **should** interface with other related Air Safety Management Systems (ASMS), notably all relevant ADHs' ASMS.

¹ ► Refer to MAA02: MAA Master Glossary. ◀ This includes civil licensed Air Traffic Control Officers (ATCOs) at MOD Aerodromes.

² ► Refer to MAA02: MAA Master Glossary. ◀

³ ► Refer to ◀ RA 1200 – ► ◀ Air Safety Management.

⁴ ► Refer to ◀ RA 1210 – Ownership and Management of Operating Risk (Risk to Life).

⁵ ► Refer to ◀ Manual of Air Safety.

**Guidance
Material
3207(1)****Controller Fatigue Management**

5. **Personal Responsibilities.** Controllers have an individual responsibility in the avoidance of fatigue, as part of a FM System. Therefore, prior to their next planned duty cycle, individuals need to ensure that they achieve adequate rest and avoid activity detrimental to the next duty period.
6. **Controller FM Training.** FM training may be beneficial to equip personnel at all levels with the skills to identify the signs and symptoms of fatigue, and to manage the Hazards associated with fatigue. FM training, where delivered, may be incorporated into existing Air Safety training⁶ or delivered in a bespoke manner. A specific focus on fatigue-related issues may also be included in pre-deployment training.
7. **Fatigue Risk Management System (FRMS).** A FRMS is a recognized civilian methodology, based on scientific principles, that allows operators to manage the fatigue-related Hazards particular to their types of operations and context. It provides a viable alternative to traditional prescriptive duty time rules and can be supported by fatigue modelling software⁷.
8. HoEs and ADH-Facing Organizations may wish to refer to the existing body of civil aviation Fatigue Risk Management (FRM) reference material in the establishment and management of a FM System for controllers. The Civil Aviation Authority (CAA)⁸, EUROCONTROL⁹ and International Civil Aviation Organization¹⁰ have provided guidance on FRM.

⁶ ► Refer to ◀ RA 1440 – Air Safety Training.

⁷ An example of modelling software is the United States Air Force -developed Fatigue Avoidance Scheduling Tool.

⁸ ► Refer to ◀ [CAP 670](#) ATS Safety Requirements. Human Factors Part D Human Resources.

⁹ ► Refer to ◀ [EUROCONTROL](#) guidance material on Fatigue and Sleep Management.

¹⁰ ► Refer to ◀ International Civil Aviation Organization (ICAO) [Fatigue Management Guide for Air Traffic Service Providers](#).

RA 3208 – Use of Unassured Aircraft Surveillance Data by Controllers

Rationale Various electronic means are available to access unassured Aircraft surveillance data¹ including position and flight level, but the ability to verify the quality of such data or to filter out unsuitable data is not possible. The use of such data by Controllers could therefore result in the provision of inaccurate information to Aircrew leading to the development of an incorrect air picture which could increase the Risk of mid-air collision. Unassured Aircraft surveillance data is therefore only to be used to provide Aircrew with generic information to enhance their situational awareness.

Contents **3208(1): Use of Unassured Aircraft Surveillance Data**
3208(2): User Training

Regulation **Use of Unassured Aircraft Surveillance Data**

3208(1)

3208(1) Aviation Duty Holder (ADH)-Facing Organizations and Heads of Establishment **shall** ensure that Controllers only use Unassured Aircraft surveillance data to provide situational awareness to Aircrew.

Acceptable Means of Compliance
3208(1)

Use of Unassured Aircraft Surveillance Data

1. Unassured Aircraft surveillance data **should** only be used to provide Aircrew with generic information in order to enhance their situational awareness.
2. Where the use of unassured Aircraft surveillance data is permitted, it **should** be used independently of assured surveillance systems. Controllers **should not** attempt to correlate and supplement assured surveillance data with unassured Aircraft surveillance data.
3. The use / intended use and the parameters of when unassured Aircraft surveillance data can be used to provide situational awareness to Aircrew **should** be subject to approval by Front Line Command (FLC) and MOD contract authorities² using extant Air Safety Management³ processes.
4. Where the use of unassured Aircraft surveillance data is permitted, relevant ADHs / Accountable Managers (Military Flying) **should** be informed as its use could affect their Air System Safety Case(s)⁴.
5. When unassured Aircraft surveillance data is being used to provide situational awareness to Aircrew, the associated software / hardware **should** be maintained in accordance with the manufacturers / service providers policy of through-life support.
6. To ensure that it is clear to Aircrew when unassured Aircraft surveillance data is being utilized, the following phraseology **should** be employed:

“C/S, report of traffic 5 miles west of Marston (generic geographic position), estimated height (if available), glider reported by ... (additional information as required)”

Guidance Material
3208(1)

Use of Unassured Aircraft Surveillance Data

7. The live Aircraft surveillance data that is displayed in programmes and applications is supplied from various surveillance sources including Flight Alarm (FLARM) receivers, ADS-B receivers (receiving Aircraft transmissions from certified or uncertified Aircraft equipment), Mode S receivers, and multilateration using multiple sensors. The quality (including integrity, accuracy and latency) of such data may vary

¹ In the context of this RA, unassured Aircraft surveillance data refers to live Aircraft surveillance data that is either accessed via a downloaded programme, internet web page or an application and that is viewed on a smart phone, tablet, laptop or other display equipment.

² In the context of this RA ‘contract authority’ refers to a non-military organization contracted to deliver or support military aviation activity.

³ Refer to RA 1200 – Air Safety Management.

⁴ Refer to RA 1205 – Air System Safety Cases.

**Guidance
Material
3208(1)**

depending on the different sources of data that are fed into the application and cannot therefore be relied upon.

**Regulation
3208(2)****User Training**

3208(2) Where the use of unassured Aircraft surveillance data is permitted, Controllers **shall** be appropriately trained in its application.

**Acceptable
Means of
Compliance
3208(2)****User Training**

8. FLC / MOD contract authorities² **should** issue orders / instructions detailing the training requirement for the use of unassured Aircraft surveillance data.

**Guidance
Material
3208(2)****User Training**

9. Nil.

RA 3221 - Enhanced Air Traffic Services Units

Rationale

Military ► **Aircraft** ◄ require access to controlled airspace in the UK Flight Information Region (FIR) / Upper Information Region (UIR) to meet training and operational requirements. The provision of Air Traffic Services (ATS) for such activity provides a barrier which mitigates the Risk to Life (RtL) of mid-air collision. ATS in controlled airspace may only be delivered by units with the appropriate approval from the Civil Aviation Authority (CAA) in order to meet ► **United Kingdom** ◄ obligation under the European Council Implementing Regulation ► **2018/1139** ◄¹. This Regulatory Article specifies the requirements for ATS provision in active Temporary Reserved Areas (TRAs) in Class C airspace and in Control Zones (CTR) / Control Areas (CTA) by a unit other than the notified airspace controlling authority.

Contents

3221(1): Enhanced Air Traffic Services Units

Regulation 3221(1)

Enhanced Air Traffic Services Units

3221(1) Only units approved by the CAA **shall** provide ATS within active TRAs in Class C airspace, or within an Aerodrome CTR / CTA, when they are not the designated Controlling Authority.

Acceptable Means of Compliance 3221(1)

Enhanced Air Traffic Services Units

1. A unit **should** be designated as an Enhanced Air Traffic Services Units (ATSU), by approval from the CAA², in order to provide a military ATS within an active TRA in Class C airspace, or within an Aerodrome CTR / CTA when they are not the designated Controlling Authority, with the exception of ► **Swanwick Military (78 Sqn)** ◄³ or an ARU⁴.
2. **TRA.** Enhanced ATSUs **should** only provide UK Flight Information Services (FIS) within an active TRA which is included in their CAA approval. ► **Aircraft** ◄ controlled by Enhanced ATSUs **should not** enter or cross airways within a TRA that ► **is** ◄ active during TRA activation hours.
3. **CTR / CTA.** The following options for implementation **should** be considered:
 - a. The provision of a combined facility using shared communication, navigation and surveillance infrastructure in order to deliver surveillance based ATS associated with the participating Aerodromes, or;
 - b. Separate facilities from which ATS ► **is** ◄ provided wholly, or partly, in accordance with (iaw) formal delegation arrangements. Where such arrangements are considered to be appropriate, greater emphasis **should** be placed on the interoperability and communication infrastructure required to support such operations and in particular the contingency and recovery arrangements put in place by both units.
4. **Criteria for Enhanced ATSUs.** Aviation Duty Holders (ADHs) and Heads of Establishment (HoEs) applying for Enhanced ATSU status **should** demonstrate

¹ ► Refer to [CAP 2020A00: Basic Regulation 2018/1139](#) ◄ (commonly referred to as the 'Basic Regulation') ► ◄.

² CAA approval is detailed in [CAA Safety and Airspace Regulation Group \(SARG\) Policy](#); ATS Provision within Controlled Airspace by Units not Notified as the Controlling Authority including Annex B, ATS Provision Within Activated Temporary Reserved Areas (TRA) by Enhanced ATSU and Annex D, ATS Provision within an Aerodrome CTR / CTA.

³ ► **Swanwick Military (78 Sqn)** ◄ is designated by the MOD as the Controlling Authority for en-route Operational Air Traffic (OAT) ATS provision. Furthermore, given its co-location with and shared use of National Air Traffic Services (NATS) infrastructure and systems, which are approved for use by the CAA; the requirement to seek additional Autonomous Radar Unit (ARU) status is waived.

⁴ ► Refer to ◄ RA 3222 – Autonomous Radar Units.

**Acceptable
Means of
Compliance
3221(1)**

compliance with the following requirements:

- a. **Personnel.** The ATS provider **should** demonstrate that it is resourced with sufficient suitably qualified controllers⁵ and support staff to undertake the task defined within the application.
 - b. **Technical Requirements.** The ATS provider **should**, as a minimum, meet the applicable military technical standards⁶ and functionality requirements for surveillance and communication. Authorization will be considered by the CAA in consultation with Defence Airspace and Air Traffic Management (DAATM). Specifically:
 - (1) **Surveillance Requirements.** ATS providers **should** demonstrate that they are equipped with surveillance equipment which meets the surveillance coverage and redundancy requirements set out within CAP 670⁷ and / or DefStan 00-972 (as appropriate to the submission) and is commensurate with the defined task. Where such requirements are not met, these **should** be detailed within the unit's Hazard analysis with appropriate contingency mitigations, including to address the Risk of sensor failure. Where ► **Aircraft** ◀ are operating close to the lateral and / or vertical limits of surveillance coverage, ATS providers **should** inform the pilot of reductions in the provision of traffic information iaw CAP 774.
 - (2) **Communication Requirements:**
 - (a) **Land-based.** Land-based ATSU providers **should** demonstrate that they are equipped with communications equipment and systems which meet the requirements stipulated within CAP 670⁸ and / or DefStan 00-972 and are commensurate with the defined Enhanced ATSU task.
 - (b) **Maritime.** Communication requirements for Royal Navy (RN) ships seeking authorization to provide ATS within an active TRA **should** be considered by DAATM on a case-by-case basis.
 - (c) **Airborne.** Airborne ATS providers **should** demonstrate that they can maintain continuous 2-way radio contact with both the ► **Aircraft** ◀ under their control and the Control and Reporting Centre (CRC) tasked as their Weapons Manager. The latter **should** be able to act as a point of contact with the Area Control Centre (ACC) and other land-based ATS providers as necessary to facilitate co-ordination requirements.
5. **CTR / CTA.** In addition, for control within a CTR / CTA, a Letter of Agreement (LOA) **should** be agreed between the applicant, the notified airspace controlling authority and other relevant parties as identified on a case-by-case basis. The LOA **should** include:
- a. Definition of both the task to be undertaken by all ATS providers involved in the agreement and the applicable terms and conditions including, where appropriate, the priorities that will be afforded to interacting departure and arrival profiles from each unit.
 - b. Detailed procedures for the sharing of, and right of access to, airspace specified within the agreement and the associated co-ordination procedures to be employed.
 - c. Description of agreed contingency procedures including the criteria and procedures for the suspension of the LOA.
 - d. A narrative description and graphical depiction of the lateral and vertical limits of the specified Area of Operations in which the ATSU will operate.

⁵ Controllers that have successfully completed a MOD or CAA approved course to support the task required, and either hold a local operating endorsement or be undergoing training with an instructor or screen controller.

⁶ ► Refer to ◀ [CAP 670](#) – ATS Safety Requirements and DefStan 00-972.

⁷ ► Refer to ◀ [CAP 670](#) – Part C, Section 3: SUR 01.

⁸ ► Refer to ◀ [CAP 670](#) – Part C, Section 1: COM.

**Guidance
Material
3221(1)**

Enhanced Air Traffic Services Units

6. Enhanced ATSU status has been granted to a limited number of units⁹, the list may be obtained from DAATM.
7. **TRAs.** Details of TRAs (including activation times) can be found in the UK Aeronautical Information Publication (AIP), En-route Information. Within an active TRA, UK FIS¹⁰ applies for the provision of ATS, not Class C rules for Radar Control. If doubt exists over the activation status of a TRA, the Military Airspace Booking Coordination Cell (MABCC) is to be consulted.
8. **Non-UK Military Air Surveillance and Control System (ASACS) Units.** ASACS units which are not UK military are constrained to the provision of Tactical Information¹¹ only within active TRAs and are not permitted by the CAA to provide UK ATS, except within airspace segregated for the activity.
9. **CTR / CTA.** Within a CTR / CTA, control services must be provided iaw the airspace classification and the pilot's Flight Rules.
10. The requirements to hold Enhanced ATSU status to provide ATS in a CTR / CTA when ►they are◄ not the notified airspace authority does not apply to the Balder CTA or Ekofisk CTA where the MOD retains the right to operate with 'Due Regard'¹².
11. **Approval Procedure.** ADHs or HoEs seeking Enhanced ATSU status will undertake Hazard identification, Risk Assessment and mitigation iaw applicable MAA Regulatory Publications (MRP) safety regulations¹³ and single service policy, in order to confirm that the unit is able to provide an ATS to ►Aircraft◄ operating within the airspace required. This assessment ►will◄ address all aspects of the ATS system, and thus encompass personnel, training, ATS procedures and equipment. In developing the Risk Assessment, particular regard ►will◄ be given to contingencies in the event of unserviceabilities.
12. **Equipment standards.** Surveillance requirements in Def Stan 00-972►¹⁴◄ are predominately based upon airfield equipment. For submissions for en-route airspace, surveillance equipment standards may be found in CAP 670, specifically the requirement for dual-sensors.
13. Applications for Enhanced ATSU status will be made through the appropriate chain of command to DAATM. DAATM, in turn, will co-ordinate such requests with the MAA for oversight to ensure all relevant military requirements have been addressed prior to submission to the CAA¹⁵.
14. **CTR / CTA.** The assessment for ATS provision in a CTR / CTA ►will◄ also include the additional considerations:
- Communication, navigation and surveillance infrastructure.
 - The interaction and deconfliction of ATS procedures including lateral separation requirements, the interaction of Instrument Flight Rules (IFR) and Visual Flight Rules (VFR) flights, responsibilities for the issuance of IFR, VFR and Special VFR (SVFR) clearances, runway selection protocols and Surveillance ►Minimum◄ Altitude Charts / Radar Vector Charts.
 - The classification of the airspace, delineation of internal CTR / CTA boundaries and the limits of delegation or shared access.
 - Altimeter setting procedures.
 - Aircraft emergencies, notification requirements and contingency arrangements.
 - Qualification and training of personnel.

⁹ This only applies to MOD Air Traffic Control, UK Air Surveillance and Control ►System◄ (ASACS) Units and Maritime platforms.

¹⁰ ►Refer to◄ RA 3224 - UK Flight Information Services and [CAP 774](#) UK Flight Information Services.

¹¹ ►Refer to◄ NATO Tactical Control Rules. iaw Allied Administrative Publication (AAP)-49 Air Control Terms and Definitions and STANAG 1183, NATO Qualifications For Fixed Wing Above Water Warfare (AWW) / Air Defence (AD) AS Controllers (ATP-81), accessed via UK Defence Standardization listings, [StanMIS](#).

¹² Subject to the conditions set out within UK AIP ENR 1.4 paragraph 2.4.1.1 - Note 4.

¹³ ►Refer to◄ MRP 1000 Series, DefStan 00-972 and ATM 3000 Series - RA 3120 to 3140 for Surveillance Equipment Safety Cases and Release To Service requirements.

¹⁴ ►Refer to Def Stan 00-972 - Military Air Traffic Services Equipment Safety and Performance Standards (Aerodrome, Terminal and Naval Air Traffic Services).◄

¹⁵ Where applications for Enhanced ATSU status are associated with an Airspace Change Proposal (ACP), the CAA will consider the application alongside the ACP and will issue its decision co-incident with the regulatory decision on the ACP.

Intentionally Blank for Print Pagination

RA 3222 – Autonomous Radar Units

Rationale

Military ► Aircraft ◀ require access to controlled airspace in the UK Flight Information Region (FIR) / Upper Information Region (UIR) to meet training and operational requirements. The provision of Air Traffic Services (ATS) for such activity provides a barrier which mitigates the Risk to Life (RtL) of mid-air collision. ATS in controlled airspace may only be delivered by units with the appropriate approval from the Civil Aviation Authority (CAA) in order to meet ► United Kingdom ◀ obligation under the European Council Implementing Regulation ► 2018/1139 ◀¹. This Regulatory Article specifies the requirements for ATS provision inside en-route Controlled Airspace (CAS) by a unit other than the notified airspace controlling authority.

Contents

3222(1): Autonomous Radar Units

Regulation 3222(1)

Autonomous Radar Units

3222(1) Only units approved by the CAA **shall** provide ATS inside en-route CAS within the UK FIR / UIR.

Acceptable Means of Compliance 3222(1)

Autonomous Radar Units

1. Where a requirement exists for the provision of ATS within en-route CAS, the unit **should** be designated as an Autonomous Radar Unit (ARU), by approval from the CAA², with the exception of:

- a. The notified airspace controlling authority;
- b. National Air Traffic Services (NATS) Swanwick Area Control Centre (ACC);
- c. NATS Prestwick ACC;
- d. ► Swanwick Military (78 Sqn) ◀ ACC³;
- e. Units providing VFR ATS in Class E en-route airspace⁴.

2. **Criteria for ARU.** Aviation Duty Holders (ADHs), Heads of Establishment (HoEs) and Duty Holder (DH)-Facing Organizations applying for ARU status **should** demonstrate compliance with the following requirements:

- a. **Personnel.** The unit **should** demonstrate that it is resourced with sufficient suitably qualified controllers⁵ and support staff to undertake the task defined within the application.
- b. **Technical Requirements.** The unit **should**, as a minimum, meet the applicable military technical⁶ and functionality requirements. They **should** demonstrate that they are equipped with suitable surveillance and communication equipment capable of undertaking the autonomous radar task. Specifically, the unit **should** provide the CAA with a Safety Assessment that

¹ ► Refer to CAP 2020A00: Basic Regulation 2018/1139 ◀ (commonly referred to as the 'Basic Regulation') ► ◀.

² CAA approval is detailed in CAA Safety and Airspace Regulation Group (SARG) Policy; ATS Provision within Controlled Airspace by Units not Notified as the Controlling Authority including Annex A, ATS Provision by ARUs and Annex C, ATS Provision within En-Route Class E Airspace.

³ ► Swanwick Military (78 Sqn) ◀ is designated by the MOD as the Controlling Authority for en-route Operational Air Traffic (OAT) ATS provision. Furthermore, given its co-location with and shared use of NATS infrastructure and systems, which are approved for use by the CAA; the requirement to seek additional ARU status is waived.

⁴ ► Refer to ◀ RA 3223 - Provision of Air Traffic Service Inside Controlled Airspace.

⁵ Controllers that have successfully completed a MOD or CAA approved course to support the task required, and either hold a local operating endorsement or be undergoing training with an instructor or screen controller.

⁶ ► Refer to ◀ CAP 670, ATS Safety Requirements and DefStan 00-972 ► - Military Air Traffic Services Equipment Safety and Performance Standards (Aerodrome, Terminal and Naval Air Traffic Services). ◀

**Acceptable
Means of
Compliance
3222(1)**

affirms that the equipment intended to be used by an ARU safely supports the ATS to be discharged⁷. Authorization will be considered by the CAA in consultation with Defence Airspace and Air Traffic Management (DAATM). The following **should** be considered to be the minimum surveillance and communication requirements. These **should** be enhanced where necessary in order to meet any additional safety requirements identified during the Risk Assessment phase of the application:

- (1) **Surveillance Requirements.** The unit **should** demonstrate that they are equipped with primary surveillance radar (PSR) and secondary surveillance radar (SSR)⁸ equipment which meets the surveillance coverage and redundancy requirements set out within CAP 670⁹ and / or DefStan 00-972¹⁰ (as appropriate to the submission) and is commensurate with the defined ARU task. Where such requirements are not met, these **should** be detailed within the unit's Hazard Analysis with appropriate contingency mitigations, including measures necessary to address the Risk of sensor failure.
- (2) **Communication Requirements:**
 - (a) **Land-based.** Land-based units **should** demonstrate that they are equipped with communications equipment and systems which meet the requirements stipulated within CAP 670¹¹ and / or DefStan 00-972 and are commensurate with the defined ARU task.
 - (b) **Maritime.** Communication requirements for Royal Navy (RN) ships applying for ARU approval **should** be considered by the CAA and DAATM on a case-by-case basis.
 - (c) **Airborne.** Airborne units **should** maintain continuous 2-way radio contact with both the **Aircraft** under their control and the Control and Reporting Centre (CRC) tasked as their Weapons Manager. The latter **should** act as a point of contact with the ACC and other land-based ATS units as necessary to facilitate co-ordination requirements.
3. In addition a Letter of Agreement (LOA) **should** be agreed between the applicant, relevant ACC, other ATS units with overlapping or adjoining airspace and other relevant parties as identified on a case-by-case basis. The LOA **should** include:
 - a. Definition of both the task to be undertaken by the ARU and the terms and conditions applicable to autonomous radar operations.
 - b. Detailed procedures for the sharing of, and right of access to, airspace specified within the agreement and the associated co-ordination procedures to be employed.
 - c. Description of agreed contingency procedures including the criteria and procedures for the suspension of the LOA.
 - d. A narrative description and graphical depiction of the lateral and vertical limits of the specified Area of Operations in which the ARU will operate.

⁷ Military units **should** refer to [ATM 3000 Series](#) - RA 3120 to 3140 for Surveillance Equipment Safety Cases and Release To Service requirements. Where Surveillance Equipment meets this requirement it **should** be considered acceptable by the CAA.

⁸ Automatic Dependant Surveillance Broadcast (ADS-B) and Wide Area Multilateration (WAM) are acceptable alternatives to SSR.

⁹ **Refer to** CAP 670 - Part C, Section 3: SUR 01.

¹⁰ **Refer to DefStan 00-972 - - Military Air Traffic Services Equipment Safety and Performance Standards (Aerodrome, Terminal and Naval Air Traffic Services).**

¹¹ **Refer to** CAP 670 - Part C, Section 1: COM.

**Guidance
Material
3222(1)****Autonomous Radar Units**

4. **CAA Approval Procedure.** ADHs, HoEs and DH-Facing Organizations seeking ARU status will undertake Hazard identification, Risk Assessment and mitigation in accordance with (iaw) applicable MAA Regulatory Publications (MRP) safety regulations¹² to confirm that the unit is able to provide an ATS to ►Aircraft◄ operating within the proposed portion of en-route CAS. This assessment ►will◄ address all aspects of the ATS system, and thus encompass personnel / training, ATS procedures and equipment.
5. **Equipment standards.** Surveillance requirements in Def Stan 00-972 are predominately based upon airfield equipment. For submissions for en-route airspace, surveillance equipment standards may be found in CAP 670, specifically the requirement for dual-sensors.
6. Military applications for ARU status will be made through the appropriate chain of command to DAATM. DAATM, in turn, will co-ordinate such requests with the MAA to ensure all relevant military requirements have been addressed prior to submission to the CAA.
7. **UK Air Surveillance and Control Service (ASACS) Units.**
- a. **Air Defence Priority Flight (ADPF).** All current UK land, surface or air-based ASACS units, with the exception of ►Crowsnest,◄ are permitted by the CAA to provide an ATS to Aircraft with ADPF status in any part of UK airspace.
- b. **ASACS Airspace Restrictions.** For operations other than those associated with ADPF status, the following airspace structures¹³ are not to be penetrated by UK ASACS units:
- (1) The main UK south-north airway and upper air route complex, from the London / Paris FIR boundary to the northern boundary of the Scottish Terminal Control Area (TMA).
 - (2) All TMAs.
 - (3) The following Control Areas (CTA)s: Clacton, Cotswold, Daventry, Midlands, Portsmouth, Severn, Southern, Strangford and Worthing.
 - (4) All Control Zones (CTR / CTZ)s and CTAs associated with an Aerodrome.
 - (5) Temporary controlled airspace established for Royal Flights.
 - (6) All airways except for the purpose of crossing.
- c. ASACS operations within the Hebrides Upper Transition Area are only to be carried out following prior notification / co-ordination with Prestwick ACC.
8. **Non-UK Military ASACS Units.**
- a. ASACS units which are not UK military units will not be considered for ARU status by the CAA and may only provide ATS within airspace segregated for the activity.
- b. Non-UK military ASACS units may provide tactical information¹⁴ within Class G airspace during exercises that are subject to prior notification via an Airspace Coordination Notice (ACN). They are not, under any circumstances, to offer or imply any form of ATS, even if requested to do so by aircrew in receipt of tactical information. Comment on the nature of control provided will be included in the ACN, which will also specify for inclusion in Special Instructions (SPINS) as a mechanism to meet the requirement to brief aircrew.

¹² DefStan 00-972 as implemented by ATM 3000 Series - RA 3120 to 3140 for Surveillance Equipment Safety Cases and Release To Service requirements.

¹³ As published in the UK Aeronautical Information Publication.

¹⁴ NATO Tactical Control Rules iaw Allied Administrative Publication (AAP)-49 Air Control Terms and Definitions and STANAG 1183, NATO Qualifications For Fixed Wing Above Water Warfare (AWW) / Air Defence (AD) AS Controllers (ATP-81), accessed via UK Defence Standardization listings, [StanMIS](#).

Intentionally Blank for Print Pagination

RA 3223 - Provision of Air Traffic Service Inside Controlled Airspace

Rationale *Different classifications of airspace require the provision of specific Air Traffic Service (ATS).*

Contents **3223(1): Provision of Air Traffic Service Inside Controlled Airspace**

Regulation 3223(1) **Provision of Air Traffic Service Inside Controlled Airspace**
 3223(1) Controllers **shall** apply the appropriate ATS in accordance with (iaw) the airspace classification in which the Air System under their control is operating.

Acceptable Means of Compliance 3223(1) **Provision of Air Traffic Service Inside Controlled Airspace**

1. Prior to an Air System entering Controlled Airspace (CAS), the controller **should** ascertain which flight rules the pilot will be operating under; controllers **should** inform pilots when they are entering and leaving different classifications of CAS¹iaw [CAP 413 Radiotelephony Manual](#). Controllers **should** state the type of ATS being provided.
2. **Radar Control Service.** Radar Control Service **should** be provided to:
 - a. All Instrument Flight Rules (IFR) flights in airspace classes A to E.
 - b. All Visual Flight Rules (VFR) flights in airspace classes B², C and D.
 - c. All Special VFR flights.
3. Radar Control Service **should** only be provided where surveillance³ coverage is available 10 nm each side of the Air System's track and, between points on the track, 10 nm from each edge of the CAS, other than as follows:
 - a. Air System's climbing into CAS subject to the following provisions:
 - (1) The base of surveillance coverage is beneath the base level of CAS.
 - (2) Transit is not permitted at a level where 5000 ft of surveillance coverage does not exist beneath the Air System unless it is subject to a Civil Air Traffic Control (ATC) clearance from the relevant sector controller (eg procedural clearance, Cleared Flight Path (CFP)⁴ or Radar Corridor (RC)⁵ clearance / activation).
4. Inside CAS controllers **should** only provide UK Flight Information Services (UK FIS) where authorized to do so, iaw RA 3224⁶, in the following circumstances:
 - a. At and above FL195 within:
 - (1) The North Wales Military Training Area (NW MTA).
 - (2) Temporary Reserved Airspace (TRA) areas 001-008 during published hours of activity.
 - b. At and above FL245 in the East Anglia MTA during published hours of activity.

¹ IFR Flights require ATC clearance to enter Class E airspace.

² No Class B airspace currently within UK FIR.

³ ATS Surveillance System: Primary Surveillance Radar (PSR), Secondary Surveillance Radar (SSR), Automatic Dependant Surveillance Broadcast (ADS-B) or any comparable system (Wide Area Multilateration (WAM)) that is used to determine the position of an Air System in range and azimuth. However, units who provide Radar Control Service inside CAS where only SSR, WAM or ADS-B is available **should** ensure local orders define procedures to cover the eventuality of an Air System whose transponder is unserviceable while operating in CAS.

⁴ Once a CFP has been obtained, the agreed track or flight level or the crossing Air System **should not** be changed without the prior approval of the civil sector controller, or the CFP automatically becomes invalid.

⁵ RC are permanently established corridors to permit military Air System to transit the civil airways structure at agreed levels, following coordination between RAF(U) Swanwick and the relevant civil sector. UK Mil AIP 5.1 - 16.

⁶ ▶ Refer to RA 3224 - UK Flight Information Services. ◀

**Acceptable
Means of
Compliance
3223(1)**

- c. Within active Managed Danger Areas (MDA) and other Danger Areas (DA) where appropriate agreements have been made, if required.
- d. Class E airspace where the Air System is operating under VFR.
5. **VFR Flights in Class E Airspace.**
- a. **Clearance.** VFR flights do not require ATC clearance to enter Class E airspace and, subject to compliance with the notified Transponder Mandatory Zone (TMZ) requirements, do not require two-way communications. VFR flights in receipt of an ATS in Class E airspace that are transitioning into Class C or D airspace **should** request a clearance, and subject to such a clearance, **should** be advised of any subsequent ATS changes.
- b. **ATS.** VFR flights that request an ATS **should** be provided with traffic information as far as practical. This **should** be achieved through the provision of the UK FIS requested by the pilot, subject to ATS unit capability to provide the requested service. The parameters and conditions for the provision of Traffic Service and Basic Service to VFR Air System's in Class E airspace are as promulgated in [CAP 774 UK Flight Information Services](#).
- c. **Instructions.** When passing instructions to VFR flights, the preferred method is through the use of geographical routing instructions. Surveillance vectors to VFR Air System's can be used as a last resort, used with extreme caution, and with special attention paid to the Unit Terrain Safe Level and terrain clearance⁷. Similarly, whenever possible, level restrictions **should** be based on an instruction to fly not above / not below a particular level rather than at a specified level. However, Air System's that have accepted surveillance vectors **should not** be subjected to level restrictions. When surveillance is used to monitor the conduct of a VFR flight, there is no requirement for the controller to advise the pilot that ►their◄ Air System has been identified unless, or until, the controller provides the pilot with surveillance vectors.
- d. **VFR Flights unable to maintain Visual Met Conditions (VMC).** If a pilot of a VFR Air System reports that they are unable to maintain VMC the controller **should**:
- (1) Provide Radar Control Service and separate AS as soon as practicable (if the Air System is in contact with a unit authorized to provide such a service). Reduced vertical separation may be applied as necessary until standard separation is able to be applied. Essential traffic information **should** be provided.
 - (2) If the Air System is in contact with an ATS unit that is not authorized to provide Radar Control Service, the controller **should**:
 - (a) Instruct the Air System to squawk Transponder code A 7700.
 - (b) Pass essential traffic information and provide collision avoidance advice where the controller considers that a definite risk of collision exists.
 - (c) Pass information to the relevant en-route sector and any other ATC agencies as necessary.
 - (3) Pilots operating without an ATS that are unable to maintain VMC **should**:
 - (a) Squawk Transponder code A 7700.
 - (b) Contact the airspace controlling authority, or an appropriate autonomous radar unit⁸, or Distress & Diversion Cell UHF 243.0 MHz or VHF 121.5 MHz.
6. **Procedural Service.** Procedural Service **should** only be provided by controllers who are specifically trained and authorized to do so.

⁷ Refer to RA 3231 – Terrain Safe Level and Terrain Clearance.

⁸ Refer to RA 3222 – Autonomous Radar Units.

**Guidance
Material
3223(1)****Provision of Air Traffic Service Inside Controlled Airspace**

7. Radar Control Service is an ATS under which pilots follow mandatory instructions to enable the prescribed separation minima between Air System to be maintained. Such mandatory instructions will generally be associated with essential details of conflicting traffic. Pilots ► **will** ◀ not change heading or level without prior approval of the Radar Controller.
8. When an Air System completes a crossing of CAS, and in the absence of a request to the contrary, controllers will reapply the type of ATS being provided prior to Radar Control Service without recourse to the pilot.
9. **VFR Traffic in Class D Airspace.** Instructions issued to VFR flights in Class D airspace are mandatory. These may comprise routeing instructions, visual holding instructions, level restrictions, and information on collision hazards, in order to establish a safe, orderly and expeditious flow of traffic and to provide for the effective management of overall ATC workload.
10. Routeing instructions may be issued which will reduce or eliminate points of conflict with other flights, such as final approach tracks and circuit areas, with a consequent reduction in the workload associated with passing extensive traffic information. Visual Reporting Points may be established to assist in the definition of frequently utilised routes and the avoidance of instrument approach and departure tracks. Where controllers require VFR AS to hold at a specific point pending further clearance, this is to be explicitly stated to the pilot.
11. When issuing instructions to VFR flights, controllers are to be aware of the overriding requirements for pilots to remain in VMC, to avoid obstacles and to remain within the privileges of their licence. This may result in the pilot requesting an alternative clearance, particularly in marginal weather conditions.
12. Controllers are to exercise caution when vectoring VFR flights, a geographical routeing instruction is preferable. Prior to vectoring, the controller will establish with the pilot the need to report if headings issued are not acceptable due to the requirements to remain in VMC, avoid obstacles, and comply with the low flying rules. Controllers are to be aware that pilots of some VFR flights may not be sufficiently experienced to comply accurately with vectors, or to recover to visual navigation after vectoring.
13. **En-Route Operations.** ICAO defines these as operations conducted on published air routes, direct point-to-point operations between defined waypoints (direct point-to-point operations include transit to / from airspace reservations and other operating areas), or along great circle routes, which are other than take-off, landing, departure, arrival or terminal operations. This includes all transit flights outside published ATS routes in receipt of an ATS from either a civil or military ATS provider.
14. **On-Route (ATS).** This term is used routinely by ATC for coordination purposes within the UK. Civil / military Air System are considered to be 'on-route (ATS)' when flying along the alignment and within 5 nm of the centre-line of published parameters of an upper ATS route (UAR) and other areas defined for the application of reduced coordination procedures.
15. **Off-Route (ATS).** This term is used routinely by ATC for coordination purposes within the UK; Air System's are considered to be 'off-route (ATS)' when not complying with the conditions at paragraph 14.
16. Arrangements between civil and military units to declare 'off-route' status will be specified in Unit Orders.

Intentionally Blank for Print Pagination

RA 3224 – ► UK ◀ Flight Information Services (FIS) ► ◀

Rationale *Controllers are required to provide a range of Air Traffic Services (ATS) in order to provide and maintain a safe and expeditious flow of air traffic.*

Contents 3224(1): ► UK ◀ Flight Information Services (FIS) ► ◀

Regulation 3224(1)

► UK ◀ Flight Information Services (FIS) ► ◀

3224(1) Within the UK Flight Information Region (FIR), ► controllers shall apply UK FIS in accordance with the airspace classification in which the Air System under their control is operating ◀.

Acceptable Means of Compliance 3224(1)

► UK ◀ Flight Information Services (FIS) ► ◀

1. ► UK FIS. UK ◀ FIS should be provided in accordance with [CAP 774 UK Flight Information Services](#).
2. ► NATO Control Rules ◀. Where provision of ► UK ◀ FIS in accordance with [CAP 774 UK Flight Information Services](#), is not appropriate, NATO Control Rules in accordance with Allied Administrative Publication ([AAP](#))-49 [Air Control Terms and Definitions](#) and [STANAG 1183, NATO Qualifications For Fixed Wing Above Water Warfare \(AWW\)/Air Defence \(AD\) AS Controllers](#) (ATP-81), should be provided where personnel are suitably trained and authorized.
3. ► Procedural Service¹ ◀. Procedural Service should only be provided by controllers who are specifically trained and authorized to do so.

Guidance Material 3224(1)

► UK ◀ Flight Information Services (FIS) ► ◀

4. UK FIS may be utilised outside of the UK FIR where specified in Local/Unit Orders.

¹ [CAP 774 UK Flight Information Services](#) Ch 5.

Intentionally Blank for Print Pagination

RA 3225 – Mandatory Air Traffic Control Instructions

Rationale

In order to ensure safe and efficient movement of ► **Aircraft** ◀, in specified circumstances it is vital that pilots comply with Air Traffic Control (ATC) Instructions.

Contents

3225(1): Mandatory Air Traffic Control Instructions

Regulation 3225(1)

Mandatory Air Traffic Control Instructions

3225(1) Controllers' instructions to pilots **shall** be mandatory in specified circumstances.

Acceptable Means of Compliance 3225(1)

Mandatory Air Traffic Control Instructions

1. **Mandatory Instructions.** Controllers and pilots **should** consider ATC instructions to be mandatory in the following circumstances:

- a. All flights within Controlled Airspace (CAS) under Instrument Flight Rules (IFR), and flights within CAS under Visual Flight Rules (VFR) within Class B, C and D.
- b. Military ► **Aircraft** ◀ flying within a Military Air Traffic Zone (MATZ) or Carrier Control Zone¹.
- c. When taxiing ► **Aircraft** ◀ on the Apron or Manoeuvring Area anywhere on a military Aerodrome unless local Aerodrome Orders make specific alternative provision.

Guidance Material 3225(1)

Mandatory Air Traffic Control Instructions

2. **Mandatory Instructions.** In accordance with RA 2115²◀, ►◀ the ► **Aircraft** ◀ Commander remains entirely responsible for the Safety of the ► **Aircraft** ◀, its occupants and equipment.
3. Other than in the circumstances described at para 1, controllers will not normally issue mandatory instructions; however, they may relay instructions of an operational nature (eg, diversion instructions) on behalf of an operating authority when ordered or authorized to do so. In such cases controllers will, if time permits, specify the authority.
4. **Advisory Instructions.** Advisory ATC instructions may be issued by controllers to pilots whenever mandatory instructions do not apply. Nevertheless, where compliance with ATC instructions is optional, a controller may assume that a pilot receiving an Air Traffic Service will comply with such instructions unless ► **they** ◀ state otherwise.

¹ Carrier Control Zone, an area of the same dimensions as a MATZ as defined in the UK Aeronautical Information Publication, applicable to maritime operations.

² ► Refer to RA 2115 – Aircraft Commanders. ◀

Intentionally Blank for Print Pagination

RA 3226 – Secondary Surveillance Radar

Rationale

Secondary Surveillance Radar (SSR)¹ provides controllers with essential information on ► Aircraft ◀ identity, position and level and is required to be confirmed as accurate.

Contents

3226(1): Validation of Mode 3/A Codes

3226(2): Verification of Mode C Data

3226(3): Level Occupancy using Secondary Surveillance Radar

Regulation 3226(1)

Validation of Mode 3/A Codes

3226(1) A controller assigning any Mode 3/A code **shall** validate the code as soon as possible.

Acceptable Means of Compliance 3226(1)

Validation of Mode 3/A Codes

1. Mode 3/A codes **should** be validated as follows:
 - a. A controller assigning any Mode 3/A code **should** validate the code by checking as soon as possible, either by direct reference to their surveillance display or with the assistance of another controlling agency, that the data displayed corresponds with the code which has been assigned.
 - b. If this is not the case, the pilot **should** be instructed to reset the assigned code. Where this fails to achieve display of the assigned code, then ► the pilot ◀ **should** be instructed to select SSR mode A 0000.
 - c. If a corrupt code still exists, the pilot **should** normally be instructed to switch off the transponder. However, where approved by local procedures and provided the Mode C has been verified, the corrupt code may be retained to assist identification and tracking. Associated Air Traffic Service (ATS) units **should** be informed of the retention of corrupt data.
 - d. At units where code callsign conversion equipment is in use, procedures to ensure the correct correlation of the callsign with the assigned code **should** be utilized by controllers and included in Local / Unit Orders.
 - e. Where a controller can ascertain from the Code Allocation Plan that a discrete Mode 3/A code has been assigned by a unit capable of validating the code, and has not been notified that the code is corrupt, then that code **should** be deemed validated.
2. SSR Code assignments mean that codes may be re-used in more than one area and controllers **should** therefore act with caution in areas where duplicate code allocations may occur.

Guidance Material 3226(1)

Validation of Mode 3/A Codes

3. **Code Allocation Plan.** Controllers assign Mode 3/A codes to ► Aircraft ◀ according to the Code Allocation Plan, which comprises:
 - a. Discrete codes comprising:
 - (1) Domestic codes which are allocated to ► Aircraft ◀ flying within the Areas of Responsibility (AoR) of a unit.
 - (2) Centralised SSR Code Assignment and Management System (CCAMS) codes which are assigned to international flights will normally be retained beyond the AoR of the assigning unit.

¹ Throughout this RA, any reference to SSR is equally applicable to Wide Area Multilateration and Automatic Dependant Surveillance Broadcast.

**Guidance
Material
3226(1)**

- b. Special purpose codes allocated internationally.
- c. Conspicuity codes, allocated nationally, or to specific users / units.

**Regulation
3226(2)**

Verification of Mode C Data

- 3226(2) Controllers **shall** verify Mode C data transmitted by
 ▶ Aircraft ◀ for accuracy on initial contact once the
 ▶ Aircraft ◀ has been positively identified.

**Acceptable
Means of
Compliance
3226(2)**

Verification of Mode C Data

4. Controllers **should** verify Mode C data transmitted by an ▶ Aircraft ◀ for accuracy on initial contact once the ▶ Aircraft ◀ has been positively identified.
5. Mode C data **should** be verified by one of the following methods:
 - a. By a visual check of the data readout immediately on receipt of a pilot's report giving their present or passing level². Particular care **should** be exercised when assessing the accuracy of the Mode C readout if the ▶ Aircraft ◀ is climbing or descending.
 - b. By coordination with another unit.
6. There is no requirement to monitor Mode C readouts for possible discrepancies once verification has been effected, nor is it necessary to notify a pilot whose Mode C data is within the permitted limit. However, if a controller observes a discrepancy of more than 200 ft either during initial verification or during the subsequent provision of an ATS, the controller **should**:
 - a. Ask the pilot to confirm their altimeter setting and level.
 - b. If the discrepancy remains, the pilot **should** be instructed to switch off Mode C. If independent switching of Mode C is not possible the pilot **should** be instructed to select SSR mode A 0000 to indicate a transponder malfunction.
7. A Mode C readout may be deemed verified if it is associated with a validated, or deemed validated, Mode 3/A code. Codes with which the associated Mode C data **should** be considered unvalidated and unverified are annotated accordingly in the UK SSR Code Allocation Plan.

**Guidance
Material
3226(2)**

Verification of Mode C Data

8. Mode C provides information on the vertical position of an ▶ Aircraft ◀ in flight. This information is normally displayed as a flight level, but information transmitted by an ▶ Aircraft ◀ flying below a pre-determined datum may be converted to an altitude by use of Air Traffic Control (ATC) data processing equipment.

**Regulation
3226(3)**

Level Occupancy using Secondary Surveillance Radar

- 3226(3) Controllers **shall** ensure specified criteria are met when utilizing SSR to assess level occupancy.

**Acceptable
Means of
Compliance
3226(3)**

Level Occupancy using Secondary Surveillance Radar

9. **Criteria for Assessing Level Occupancy.** The assessment of level occupancy by use of verified Mode C **should** be based on the following criteria:
 - a. **In Level Flight.** An ▶ Aircraft ◀ **should** be considered to be at an assigned level provided that the Mode C readout indicates 200 ft or less from that level.
 - b. **Vacating an Assigned Level.** An ▶ Aircraft ◀ which is known to have been cleared to vacate a level **should** be considered to have done so when the

² In this context level may refer to altitude, height or flight level.

**Acceptable
Means of
Compliance
3226(3)**

Mode C readout indicates a change of 400 ft or more in the anticipated direction.

c. **Passing a Level.** An ► **Aircraft** ◀ climbing or descending **should** be considered to have passed through a level when the Mode C readout indicates that the level has been passed by 400 ft or more in the required direction.

d. **Reaching a Level.** An ► **Aircraft** ◀ **should** be considered to have reached an assigned level when three successive Mode C readouts indicate 200 ft or less from that level.

**Guidance
Material
3226(3)****Level Occupancy using Secondary Surveillance Radar**

10. Mode C information may be used to determine whether an ► **Aircraft** ◀ has reached, is maintaining, has vacated, or is passing a level or altitude, and accordingly the vertical displacement between ► **Aircraft** ◀ and / or rate of change may be deduced.

Intentionally Blank for Print Pagination

RA 3227 – Methods of Identification

Rationale

In order to provide a surveillance service, controllers need to identify the subject Air System.

Contents

3227(1): Methods of Identification

Regulation 3227(1)

Methods of Identification

3227(1) Controllers **shall** identify Air Systems prior to providing an Air System with a surveillance service.

Acceptable Means of Compliance 3227(1)

Methods of Identification

1. Controllers **should** identify Air Systems using one of the following methods:
 - a. **Turn Method.** A turn for identification does not constitute a surveillance service. However, when turning Air System for this purpose, controllers **should** take into consideration:
 - (1) Airspace restrictions.
 - (2) The terrain in the Air System's reported, estimated or observed position.
 - (3) Other radar returns (including permanent echoes, clutter, etc).
 - (4) Surveillance coverage.
 - b. Where possible, turns **should** be used as initial positioning turns to save time and fuel.
 - c. In using the turn method, a controller **should** ascertain the Air System's heading and, following a period of track observation, **should** correlate the observed movement of a particular radar return with one or more changes of heading of at least 30°, as instructed by ► **them** ◀, by another controller, or as reported by the pilot. Where only approximate position information is available a minimum of two turns of not less than 30° **should** be used. During this procedure, a controller seeking to identify an Air System **should**:
 - (1) Verify that the movements of not more than one radar return correspond with those of the Air System.
 - (2) Exercise caution, particularly when employing this method in areas where changes of Air System heading are commonly made as a navigational routine.
 - (3) Take account of the type and characteristics of the surveillance equipment, eg, raw or processed radar, rate of scan, beam width, range scale of display, when deciding the amount of turn and the period of observation required to prove identification.
 - (4) Ensure that the manoeuvre(s) will not carry the radar return outside radar display coverage, through clutter, or into airspace, which is the subject of specific clearance.
 - d. **Turn Method Using Direction Finding (DF).** A controller **should** observe a turn of not less than 30° together with relevant DF indications and a period of track observation. Range information derived from DME, TACAN or similar equipment **should** be used to assist identification when it is available.
 - e. **Position Report Method.** This method of identification **should** consist of a period of track observation, associated with heading and position information within known radar cover based on one or more of the following:
 - (1) By correlating a particular radar return with a position report from the pilot that the Air System is:

**Acceptable
Means of
Compliance
3227(1)**

- (a) Over an exact reporting point which **should** be displayed on the radar map.
- (b) At a particular distance, not exceeding 30 nm, on a particular radial from a collocated VOR / DME or TACAN. The source facility **should** be displayed on the radar map.
- (c) Over a notified visual reporting point or prominent geographical feature approved for the purpose and displayed on the radar map, provided that the flight is operating with visual reference to the surface and at a height of 3000 ft or less above the surface.
- f. **By a DF Fix.** This method **should** be reinforced by an alternative method if there is any doubt about the identification because of:
- (1) The close proximity of other radar returns.
 - (2) Inaccurate reporting from Air System's at high level or some distance from navigational facilities.
- g. **Departing Aircraft Method.** An Air System can be identified, by observing the radar response of a pre-notified departing Air System. Identification **should** take place within 1 nm of the end of the runway in use at the departure aerodrome. Particular care **should** be taken to avoid confusion with Air System overflying, carrying out a low approach, or departing from an adjacent runway or with Air System holding overhead the aerodrome.
- h. **SSR Data.** When using SSR▶¹◀ data to identify an Air System, one of the following methods **should** be employed:
- (1) Observing the pilot's compliance with the instruction to select a discrete four digit code;
 - (2) Recognizing a validated four digit code previously assigned to an Air System callsign. When code / callsign conversion procedures are in use and the code / callsign pairing can be confirmed, the callsign displayed in the data block may be used to establish and maintain identity;
 - (3) Observing an IDENT feature when it has been requested. Caution ▶**should**◀ be exercised when employing this method because simultaneous requests for transmissions within the same area may result in misidentification. Aircraft displaying the conspicuity code 7000 ▶**should not**◀ be identified by this method.
- i. **SSR Mode 2 / Radar Responsive Beacon (RRB) Data.** For RRB data, the use of 'Chirp Single/Code/Retain' **should** be used. However, Controllers **should** guard against the risk of mis-identification, which might result from simultaneous RRB identification instructions from adjacent ships to different Air Systems in close proximity.
- j. When using Mode 2 for identification, the controller **should** clearly recognize the designated four digit Mode 2 Code individually assigned to the Air System. If any doubt exists due to garbling etc, an alternative method of identification **should** be used.
2. When providing a surveillance service to an Air System, controllers operating at SSR equipped units **should** allocate that flight with a discrete code in accordance with the SSR assignment plan. Unless otherwise directed by an ATC unit, Mode C will be selected in conjunction with Mode 3/A. Controllers ▶**should**◀, therefore, verify the accuracy of the Mode C readout when assigning discrete codes to Air Systems.
3. Identification **should** be maintained for the period the Air System is in receipt of a surveillance service and the pilot **should** be informed whenever identification is lost and subsequently re-established.

¹ ▶ Throughout this RA, any reference to SSR is equally applicable to Wide Area Multilateration and Automatic Dependant Surveillance Broadcast. ◀

**Acceptable
Means of
Compliance
3227(1)**

4. **Failure to Locate an Aircraft.** If a surveillance controller is unable to locate a primary radar return or SSR response which relates to the pilot's reported position:
- a. **The Air System is outside radar cover.** In which case the pilot **should** be instructed to climb to a higher level, call later, or call another nominated radar agency.
 - b. **The Air System return is obscured by clutter or is presenting a poor aspect to the radar aerial.** If available, an alternative radar can be selected, or the pilot **should** be instructed to change heading or call another nominated radar agency.
 - c. **The pilot's reported position is incorrect.** A further position check **should** be requested and, if the situation is still unresolved, the pilot **should** be instructed to obtain a fix from the UK Emergency Fixer Service and to pass the notified position to the controller.

**Guidance
Material
3227(1)****Methods of Identification**

5. Nil.

Intentionally Blank for Print Pagination

► This RA has been substantially rewritten; for clarity no change marks are presented – please read RA in its entirety ◀

RA 3228 – Separation Standards

Rationale

Separation standards are provided in accordance with (iaw) the airspace classification that the Aircraft are operating within, taking into account any military specific requirements. If the prescribed separation standards are not conformed with there is an increased Risk to Life in an Aviation Duty Holder's (ADHs) / Accountable Manager (Military Flying)'s (AM(MF)) operation due to the increased likelihood of Mid Air Collision (MAC). This Regulatory Article requires the application of prescribed separation criteria to reduce the likelihood of MAC and maintain a safe and expeditious flow of air traffic.

Contents

- 3228(1): Separation Requirements
- 3228(2): Separation Standards – Lateral
- 3228(3): Separation Standards – Vertical
- 3228(4): Separation Standards for Aircraft Operating in Controlled Airspace
- 3228(5): Vertical Separation Standards For Typhoon
- 3228(6): Separation Standards for Radar to Visual Recoveries

Regulation

3228(1)

Separation Requirements

3228(1) Head of ADH-Facing Organizations and AM(MF)-Facing Organizations (AA-Facing Organizations) and Head of Establishments (HoEs) **shall** ensure that appropriate separation standards are applied between Aircraft iaw the airspace classification¹ within which they are operating.

Acceptable Means of Compliance 3228(1)

Separation Requirements

1. Vertical or lateral separation iaw Table 1 **should** be applied between:
 - a. All flights in Class A airspace.
 - b. Instrument Flight Rule (IFR) flights in Class C, D and E airspace.
 - c. IFR flights and Visual Flight Rule (VFR) flights in Class C airspace.
 - d. IFR flights and Special VFR (SVFR) flights.
 - e. SVFR flights, except where a reduction is authorized by a Letter of Agreement.

Table 1 – Separation Requirements

| Class | Flight Rules | Aircraft Requirements | Separation Requirements |
|-------|--------------|---|---|
| A | IFR only | Air Traffic Control (ATC) clearance before entry. Comply with ATC instructions. | Separate all Aircraft from each other ^{Note 1} . |
| C | IFR and VFR | ATC clearance before entry. Comply with ATC instructions. | (a) Separate IFR flights from other IFR and VFR flights; (b) Separate VFR flights from IFR flights; (c) Pass Traffic Information (TI) to VFR flights on other VFR flights |

¹ Airspace Classes A to E are Controlled Airspace (CAS) and Class G is Uncontrolled Airspace.

Acceptable Means of Compliance 3228(1)

| | | | |
|----------|-------------------|--|---|
| | | | and give traffic avoidance advice if requested. |
| D | IFR, SVFR and VFR | ATC clearance before entry. Comply with ATC instructions ^{Note 2} . | (a) Separate IFR / SVFR flights from other IFR / SVFR flights ^{Note 3} ; (b) Pass TI to IFR flights and SVFR flights on VFR flights and give traffic avoidance advice when requested; (c) Pass TI to VFR flights on all other flights and provide traffic avoidance advice when requested. |
| E | IFR and VFR | IFR flights to obtain ATC clearance before entry and comply with ATC instructions. VFR flights do not require clearance ² . | (a) Separate IFR flights from other IFR flights; (b) Provide IFR flights, wherever practicable, TI and if requested by the pilot provide traffic avoidance advice on participating and non-participating VFR flights; (c) Provide VFR flights TI iaw Civil Air Publication (CAP) 774 ³ . |
| G | IFR and VFR | None. | Refer to para 2. |

Note 1:

Controllers **should** be cautious when controlling Aircraft operating at the base levels of CAS or when crossing CAS with lateral variations in base levels to ensure separation is not eroded against traffic that is subsequently crossing a lower portion of CAS.

Note 2:

Class D usually has a sole controlling authority (unless a shared agreement is in place). Any entry into Class D **should** be approved by the controlling authority.

Note 3:

Controllers will be cognisant of the condition of the SVFR clearance. Vertical / lateral separation may result in the Aircraft not being able to comply with the condition of that clearance⁴.

2. In Class G airspace, separation between Aircraft is ultimately the Responsibility of the pilot; however, when providing a Deconfliction Service, Controllers **should** provide information and advice aimed at achieving the defined deconfliction minima in CAP 774³.

3. Where Class C airspace lies above Class E airspace, separation requirements **should** be assumed to be required on descending en-route traffic, unless it is known that the traffic will be operating under VFR upon entering Class E airspace.

Avoidance of Unknown traffic

4. In all classifications of airspace and iaw the type of Air Traffic Service (ATS) being provided, standard separation **should** be provided for IFR traffic if it is known or suspected that an unknown Aircraft:

- a. Is lost or has experienced radio failure.
- b. Is not squawking / transponding.
- c. Is squawking Secondary Surveillance Radar (SSR) transponder code A 0000, 7400, 7500, 7600 or 7700.

5. Separation standards are a minima and **should** be increased when either requested by the pilot or a Controller considers it to be necessary.

² Refer to RA 3223 – Provision of Air Traffic Service Inside Controlled Airspace.

³ Refer to CAP 774 – UK Flight Information Services.

⁴ Refer to CAP 493 Chapter 2 paragraph 8 – Special VFR.

**Guidance
Material
3228(1)**

Separation Requirements

6. When a Controller issues an avoiding action to IFR Aircraft operating within Class D or E airspace and the pilot reports that they have the unknown Aircraft in sight and have positively stated that they will maintain their own separation, further Controller action can be limited to passing TI.
7. When a Search and Rescue Aircraft is escorting an Aircraft in an emergency, standard separation between them may be reduced. A minimum is not laid down within UK Flight Information Regions, therefore separation may be reduced to that which allows the Aircraft to be maintained visually or with airborne surveillance.

**Regulation
3228(2)**

Separation Standards – Lateral

- 3228(2) Head of AA-Facing Organizations and HoEs **shall** ensure that appropriate lateral separation standards are applied between Aircraft.

**Acceptable
Means of
Compliance
3228(2)**

Separation Standards – Lateral

8. Standard lateral separation in all classifications of airspace is 5 nm and **should** be applied as a minimum, except where reduced lateral separation is allowed.

Reduced Lateral Separation

9. Reduced lateral separation of 3 nm **should** only be applied iaw the following requirements:
- The surveillance system⁵ in use has been assured and approved for this purpose.
 - Both Aircraft are within assured surveillance coverage.
 - The surveillance system in use provides a data refresh rate of 5 seconds or less.
 - Both Aircraft are in receipt of an ATS from the same Controller or are the subject of coordination.
 - Both Aircraft are outside CAS, other than Class D and active Temporary Reserved Areas (TRAs) 001 – 008.
 - When the Aircraft is operating within Class E airspace and surveillance data is provided by National Air Traffic Services (NATS) and NATS has stipulated alternative separation minima.
10. **Cooperative Only Surveillance System.** Provision of an ATS using only a cooperative surveillance system **should** only be applied if the surveillance system has been assured and approved for this purpose and the HoE / AA-Facing Organization has completed the requisite Safety work.
11. **Formations.** Reduced lateral separation **should not** be applied when either speaking unit is a formation due to the fact that formation elements may be displaced by up to 1 nm, except where covered by a Safety and / or technical Assessment and RA 1200⁶.

**Guidance
Material
3228(2)**

Separation Standards – Lateral

12. Lateral separation based on radar exists when the distance between the centres of radar contacts does not represent less than the prescribed minimum, provided that the contacts do not touch or overlap⁷.

⁵ ATS Surveillance System: Primary Surveillance Radar (PSR), SSR, Wide Area Multilateration (WAM), Automatic Dependant Surveillance Broadcast (ADS-B) or any comparable system that is used to determine the position of an Aircraft in range and azimuth.

⁶ Refer to RA 1200 – Air Safety Management.

⁷ Associated with PSR returns at extremes of radar range.

**Regulation
3228(3)**

Separation Standards – Vertical

3228(3) Head of AA-Facing Organizations and HoEs **shall** ensure that appropriate vertical separation standards are applied between Aircraft.

**Acceptable
Means of
Compliance
3228(3)**

Separation Standards – Vertical

13. An Aircraft in receipt of a surveillance service, whether transponding Mode C or not can be separated from other Aircraft which are transponding Mode C but **should** be subject to the following:

a. When the transponder Mode C of the conflicting Aircraft has been verified, the following minimum vertical separation **should** apply:

(1) **Inside CAS.** 5000 ft.

(2) **Outside CAS.** 3000 ft (If the SSR transponder code indicates that the transponder Mode C data has not been verified, the surveillance returns, however presented, **should not** merge).

14. **SSR Transponder Mode A 0000.** Vertical separation using transponder Mode C **should not** be applied against Aircraft transponding Mode A 0000.

15. **Co-ordination.** When agreeing co-ordination, Controllers **should** apply no less than the following vertical separation:

a. Between subsonic Aircraft:

(1) Up to FL 290 – 1000 ft.

(2) Above FL 290 – 2000 ft. For Reduced Vertical Separation Minima (RVSM) Airspace see para 16.

b. When one or both Aircraft are supersonic:

(1) Up to FL 450 – 2000 ft.

(2) Above FL 450 – 4000 ft.

16. **RVSM.** RVSM of 1000 ft within the vertical and lateral limits of airspace notified as RVSM or RVSM transition airspace **should** only be applied if:

a. Both Aircraft are RVSM approved.

b. The surveillance display system shows the RVSM approval status of all Aircraft involved to the respective Controllers and the Aircraft are subject to Standing Agreement Co-ordination Procedures, or co-ordination has been effected.

Reduced Vertical Separation

17. Reduced vertical separation of 500 ft **should** only be applied at Terminal Units and iaw the following requirements:

a. Both Aircraft are within the assured surveillance coverage.

b. Both Aircraft are in receipt of an ATS from the same Controller or are the subject of military to military co-ordination.

c. Both Aircraft are below FL 100 and outside CAS other than Class D.

18. The application of reduced vertical separation to civil Aircraft and Military Aircraft equipped with a Airborne Collision Avoidance System⁸ **should** be exceptional rather than routine and only following agreement with the pilot.

19. Where CAS is adjoined vertically by Class G airspace, Aircraft can operate at the lower limit of Control Areas (CTA) (including Terminal Manoeuvring Areas) and are deemed to be operating outside CAS. Pilots operating at these levels and in communication with an ATC Unit **should** be provided with UK Flight Information Services iaw CAP 774³. Controllers providing an ATS to such flights **should**, as

⁸ Refer to RA 3235 – Airborne Collision Avoidance Systems (ACAS) and Terrain Awareness and Warning Systems – Controllers Responsibilities.

Acceptable Means of Compliance 3228(3)

necessary, include a wake turbulence caution when providing TI on controlled flights operating at the lowest available level⁹.

20. **Formations.** Reduced vertical separation **should not** be applied when either speaking unit is a formation due to the fact that formation elements may be displaced by up to 100 ft, except where covered by a Safety and / or technical Assessment and RA 1200⁶.

21. **Level Occupancy using SSR** - To ensure separation standards are maintained when following an Aircraft that is in the climb or descent, only levels that will maintain standard or reduced vertical separation iaw RA 3226(3)¹⁰ **should** be applied. Controllers **should not**, under any circumstances, attempt to apply vertical separation based on the level that the other Aircraft is expected to reach at an assumed rate of climb / descent.

Guidance Material 3228(3)

Separation Standards – Vertical

22. Nil.

Regulation 3228(4)

Separation Standards for Aircraft Operating in Controlled Airspace

3228(4) Head of AA-Facing Organizations and HoEs **shall** ensure that appropriate separation standards against conflicting Aircraft¹¹ are applied iaw the classification of CAS in which an ATS is being provided.

Acceptable Means of Compliance 3228(4)

Separation Standards for Aircraft Operating in Controlled Airspace

23. When a Controller observes a conflicting Aircraft¹¹, the following actions within Table 2 **should** be taken iaw the classification of CAS.

Table 2 – Actions against conflicting Aircraft¹¹

| Class | Actions to be taken by the Controller |
|----------|---|
| A | <p>Radar tracks can merge if the Aircraft receiving the ATS is 1000 ft above / below the lower or upper limit of CAS and the Mode A Code is not that of a unit with Approval to enter CAS.</p> <p>Radar tracks can merge if the non-transponding conflicting Aircraft has not been notified as operating in CAS by the relevant Civil Sector and the Aircraft receiving the ATS is 1000 ft above / below the lower or upper limit of CAS.</p> <p>If the Aircraft receiving the ATS is at or above FL 110 and the conflicting Aircraft is transponding Mode A 7000, 7001 or 7002 without Mode C, it can be deemed to be outside the vertical confines of CAS and radar tracks can merge.</p> |
| C | <p>Conflicting Aircraft can be deemed to be outside CAS (outwith active TRAs 001-008) and radar contacts can merge so long as its Mode A is not that of a Unit with Approval to penetrate CAS.</p> <p>Aircraft receiving an ATS at FL 200, or at FL 250 above an active TRA, should be passed TI regarding conflicting Aircraft¹¹; however, the radar contacts may be allowed to merge. This dispensation should not apply to Aircraft within 5 nm of the Class C boundary in respect of conflicting Aircraft¹¹ operating within Military Training Areas and active TRAs.</p> |

⁹ Refer to CAP 413 – Radiotelephony Manual Chap 9.

¹⁰ Refer to RA 3226(3): Level Occupancy using SSR.

¹¹ In the context of this RA, 'conflicting Aircraft' refers to non transponding, Mode A only traffic or if the Mode C indicates that the traffic is outside CAS.

| | | |
|---|--|--|
| Acceptable Means of Compliance 3228(4) | Class | Actions to be taken by the Controller |
| | D | When SSR Mode C derived information indicates that the conflicting Aircraft is outside the vertical limits of the airspace and provided that at least 1000 ft separation is evident, the radar responses can be allowed to merge and TI is not required to be passed. Where 1000 ft separation does not exist, Controllers should ensure that the contacts do not merge and TI is passed. |
| | E (with a Transponder Mandatory Zone) | Radar tracks can merge if the Aircraft receiving the ATS is 1000 ft above / below the lower or upper limit of CAS (and the Mode A Code is not that of a unit with Approval to enter CAS). Radar tracks can merge if the non-transponding conflicting Aircraft has not been notified as operating in CAS by the relevant Civil Sector |

Guidance Material 3228(4)**Separation Standards for Aircraft Operating in Controlled Airspace**

24. Nil.

Regulation 3228(5)**Increased Vertical Separation Standards for Typhoon**

3228(5) Head of AA-Facing Organizations and HoEs **shall** ensure increased vertical separation standards are provided to Typhoon Aircraft, when requested by the pilot.

Acceptable Means of Compliance 3228(5)**Increased Vertical Separation Standards for Typhoon**

25. Increased vertical separation of either 2000 ft or 3000 ft, Aircraft speed dependant, **should** be applied when requested by the pilot. Standard separation for supersonic flight **should** be applied iaw para 15b.

26. If increased separation is unable to be provided, the pilot **should** be advised and will either delay acceleration or reduce speed and / or manoeuvre to comply with standard separation. This proviso is reflected in the Typhoon Release To Service.

Guidance Material 3228(5)**Increased Vertical Separation Standards for Typhoon**

27. Due to possible altimeter inaccuracies at certain airspeeds and / or when manoeuvring above specified parameters at all speeds, pilots of Typhoon Aircraft may request Controllers to provide increased vertical separation against other Aircraft. At all times the onus for providing increased terrain clearance and requesting the increased vertical separation against other Aircraft rests entirely with the pilot.

Regulation 3228(6)**Separation Standards for Radar to Visual Recoveries**

3228(6) Head of AA-Facing Organizations and HoEs **shall** ensure that until specified conditions are met, the required separation standards for radar to visual recoveries are correctly applied.

Acceptable Means of Compliance 3228(6)**Separation Standards for Radar to Visual Recoveries**

28. **Radar to Visual Recoveries.** Separation standards **should** be applied until:
- The point of confliction is in a Military Air Traffic Zone and;
 - The pilot of the Aircraft conducting the radar to visual recovery is visual with an Aircraft conducting an Instrument Approach, and;
 - TI is passed to the pilot of the Aircraft conducting the Instrument Approach, regarding the Aircraft conducting the radar to visual approach.

**Acceptable
Means of
Compliance
3228(6)**

29. When civil Aircraft are on an instrument recovery , the sequencing of radar to visual approaches **should** be exceptional rather than routine and the civil pilots' agreement **should** be sought.

**Guidance
Material
3228(6)**

Separation Standards for Radar to Visual Recoveries

30. Nil.

Intentionally Blank for Print Pagination

RA 3230 - Traffic Coordination

Rationale

Controllers may require coordination between ► **Aircraft** ◀ in order to maintain safe and expeditious flow of Air Traffic.

Contents

3230(1): Traffic Coordination

3230(2): Approved Methods of Coordination

Regulation

3230(1)

Traffic Coordination

3230(1) Coordination **shall** only be effected through negotiations between two or more parties who are vested with the authority to make executive decisions appropriate to the task being discharged.

Acceptable Means of Compliance 3230(1)

Traffic Coordination

1. Coordination **should** only be agreed between qualified controllers.
2. Coordination **should** only be effected through an agreed course of action based on known information. Responsibility for obtaining and ensuring implementation of an agreed course of action **should** be vested in one of the parties involved.

Guidance Material 3230(1)

Traffic Coordination

3. Nil.

Regulation 3230(2)

Approved Methods of Coordination

3230(2) Controllers **shall** only use approved methods of coordination.

Acceptable Means of Compliance 3230(2)

Approved Methods of Coordination

4. Controllers **should** use the following methods of Traffic Coordination:
 - a. **Tactical Coordination.** Tactical coordination is the temporary coordination of ► **Aircraft** ◀ to which the coordinating controllers are providing, or are about to provide, an Air Traffic Service (ATS). Tactical coordination **should** be achieved either verbally or silently using an electronic data communications system. The use of such a system **should** be defined in Local / Unit Orders.
 - b. **Tactical Coordination – ► Aircraft ◀ Not Yet on Frequency.** The releasing controller **should** ensure that the details of any coordination agreement are passed to the pilot in time for them to acknowledge compliance before changing frequency. This is particularly pertinent during an Aerodrome departure where the pilot can change frequency shortly after take off.
 - c. **Tactical Coordination by Proxy.** A controller can carry out coordination on behalf of another controller, provided:
 - (1) The procedure is defined and authorized in Local / Unit Orders.
 - (2) The traffic situation and time available allows the controller being represented to comply with the agreed course of action.
 - (3) Coordination of this nature is binding upon all parties involved in the agreement.
 - d. Central or combined coordination positions serving more than one controller can be established at larger units.
 - e. **Standing Agreement Coordination.** Standing agreement coordination is that coordination, which is implemented automatically, on a permanent basis, without communication between the controllers involved. It **should** only be

**Acceptable
Means of
Compliance
3230(2)**

effected in accordance with (iaw) a written standing agreement between the units or sub-units involved and **should** only be valid for the ►Aircraft◄ and circumstances specified in the agreement.

5. When describing the height or altitude of an ►Aircraft◄ for the purposes of traffic information or agreeing coordination, controllers **should** also state the pressure datum on which the ►Aircraft◄ is operating and the terms “Not Above”, “Not Below” or “Maintaining” as appropriate. Where the level of an ►Aircraft◄ is expressed as a Flight Level there is no requirement to state the pressure datum.

**Guidance
Material
3230(2)**

Approved Methods of Coordination

6. **Verbal Coordination – Direct Procedure.** When a controller seeking coordination is able to determine (eg from SSR data¹) which controller is controlling the ►Aircraft◄ against which coordination is required, the initiating controller will:

- a. Make verbal contact with the appropriate unit / console / controller and open the dialogue with the words “Request coordination”.
- b. Refer to the ►Aircraft◄ for which coordination is requested in the order most appropriate to the situation, using one of the approved identification methods iaw RA 3227².
- c. Propose a course of action upon which agreement is requested.

7. To ensure clarity and avoid misunderstandings, parties will explicitly state the decision agreed and actions required of their ►Aircraft◄ to achieve the agreed course of action.

8. **Verbal Coordination – Indirect Procedure.** When a controller intends to initiate coordination and believes, but is not certain, that another controller has responsibility for the ►Aircraft◄ against which coordination is required, the initiating controller will:

- a. Make verbal contact with the most appropriate unit / console / controller and request Traffic Information.
- b. Refer to the ►Aircraft◄ upon which information is required using one of the approved identification methods iaw RA 3227²; if the responding controller confirms that ►they are◄ controlling the relevant ►Aircraft◄, obtain details of its intentions and request coordination if appropriate.

9. **Silent Coordination.** The procedure to be followed when carrying out silent coordination will vary according to the characteristics of the data communication system in use. Where such a system is authorized for this purpose, units will issue instructions governing its use.

10. **Climbing or Descending Traffic.** When coordinating against climbing or descending traffic using either verbal or silent coordination procedures, controllers must impose on their own traffic an intermediate stop-off level to ensure maintenance of separation criteria iaw RA 3228³. In order to safeguard separation criteria, any stop-off level must be based upon a level already vacated by the other ►Aircraft◄ and not on a level expected to be reached.

11. Where combinations of lateral and vertical separation are used in the coordination of ►Aircraft◄, controllers will closely monitor tracks and levels to ensure that standard lateral separation is maintained until the requisite vertical separation exists.

12. **Reduced Vertical Separation Minima (RVSM) Airspace.** When coordinating ►Aircraft◄ that are operating, or are about to operate, within RVSM designated airspace, unless the status is known to be self-evident to both controllers, the RVSM approval status (either RVSM Compliant or Negative RVSM) of the individual ►Aircraft◄ involved will be included in the coordination message.

¹ Throughout this RA, any reference to SSR is equally applicable to Wide Area Multilateration and Automatic Dependant Surveillance Broadcast.

² Refer to RA 3227 – Methods of Identification.

³ Refer to RA 3228 – Separation Standards.

RA 3231 – ► Air Traffic Control Unit ◀ Terrain Safe Level and Terrain Clearance

Rationale

► *Controlled Flight into Terrain (CFIT) is a recognized Risk to low flying activity. Without a known Air Traffic Control (ATC) Unit Terrain Safe Level¹ there is an increased Risk of CFIT. ATC Unit ◀ Terrain Safe Levels need to be established to mitigate the Risk of CFIT ► and to ensure that Controllers are ◀ aware of their responsibilities regarding terrain clearance when an Air Traffic Service (ATS) ► is provided. ◀*

Contents

3231(1): ► Air Traffic Control Unit ◀ Terrain Safe Level
3231(2): Controllers' Responsibility for Terrain Clearance

Regulation

3231(1)

► Air Traffic Control Unit ◀ Terrain Safe Level

3231(1) ► **ATC Unit ◀ Terrain Safe Levels shall** be detailed in Unit Orders ►²◀.

Acceptable Means of Compliance

3231(1)

► Air Traffic Control Unit ◀ Terrain Safe Level

1. When providing an ATS, Controllers **should** take account of ► the ATC Unit ◀ Terrain Safe Levels.
2. Controllers **should** only descend an ► Aircraft ◀ below the ► ATC Unit ◀ Terrain Safe Level when;
 - a. ► Authorized to do so under a specific procedure or a Front Line Command Order. ◀
 - b. In support of an ► Aircraft ◀ emergency.
 - c. When the pilot is in visual contact with the surface.
 - d. When the pilot is using terrain-following radar equipment.
 - e. When ► Aircraft ◀ are operating from / to a ship in accordance with (iaw) BRd 766 ►³◀.

Guidance Material

3231(1)

► Air Traffic Control Unit ◀ Terrain Safe Level

3. ► Responsibilities for ATS units where Aircraft conduct Radar to Visual Recoveries and Short Pattern Circuits will be iaw RA 3232⁴ ◀

Regulation

3231(2)

Controllers Responsibility for Terrain Clearance

3231(2) Controllers **shall** be responsible for terrain clearance under specified conditions associated with the ATS being provided and / or the airspace classification in which an ► Aircraft ◀ is operating.

Acceptable Means of Compliance

3231(2)

Controllers Responsibility for Terrain Clearance

4. Controllers **should** be responsible for terrain clearance ► as follows. ◀
 - a. ► When ◀ Radar Control is being provided to Aircraft operating under Instrument Flight Rules (IFR).

¹ ► Refer to MAA 02: MAA Master Glossary.

² Includes Air Traffic Control Centres (ATCCs) and UK Airspace Surveillance and Command System (ACACS) Unit.

³ Refer to BRd 766 – Embarked Aviation Orders.

⁴ Refer to RA 3232 – Provision of Vectors to Air Systems conducting Radar to Visual Recoveries or Short Pattern Circuits below the Air Traffic Control Unit Terrain Safe Level. ◀

**Acceptable
Means of
Compliance
3231(2)**

b. **Class A ► Airspace. ◀** Controllers **should** ensure that levels assigned to IFR flights in receipt of a Radar Control Service provide adequate terrain clearance for the phase of flight as follows:

- (1) Final Approach. Controllers **should** allocate levels iaw the approved procedure.
- (2) Within the Surveillance Minimum Altitude Chart (SMAC) or Radar Vector Chart (RVC) Area, levels allocated **should** be iaw the information published on the SMAC / RVC.
- (3) Within 30 nautical miles (nm) of the Surveillance Antenna. The antenna **should** be that which is being used to provide the ATS. Levels allocated **should** be 1000 ft above any fixed obstacle within:
 - (a) 5 nm of the ► Aircraft ◀, and;
 - (b) 15 nm ahead and 20° either side of the ► Aircraft's ◀ track.
 - (c) When the ► Aircraft ◀ is within 15 nm of the antenna and, provided a SMAC or RVC or approved procedure has been notified, the 5 nm in (a) and 15 nm in (b) may be reduced to 3 nm and 10 nm respectively.
- (4) Outside the Above Phases. Levels allocated **should** be 1000 ft above any fixed obstacle:
 - (a) Which lies within 15 nm of the centreline of any Airway (for flights on Airways); or
 - (b) Within 30 nm of the ► Aircraft ◀ (for all other flights).

Note: In sections of Airways where the base is defined as a Flight Level, the lowest useable level normally provides not less than 1500 ft terrain clearance.

c. **Class E ► Airspace. ◀** Responsibility for terrain clearance for IFR flights is as follows:

- (1) Controllers utilizing surveillance-derived data to provide a service to IFR flights are responsible for terrain clearance through the use of the relevant RVC, ► SMAC ◀ or equivalent system.
- (2) When surveillance-derived data is not available, the pilot remains responsible for terrain clearance, but Controllers **should not** assign a level to the pilot below the relevant sector safe altitude. The pilot **should** be advised that surveillance-derived data is not available and that ► they are ◀ responsible for terrain clearance.

d. **Visual Flight Rules (VFR) and Special Visual Flight Rules (SVFR) inside Controlled Airspace.** Controllers have no responsibility for terrain clearance of these flights, even if they accept vectors; however, Controllers **should not** assign levels to ► Aircraft ◀ operating under VFR or SVFR which accept vectors.

5. **Class G ► Airspace. ◀** In Class G ► Airspace ◀, terrain clearance responsibilities **should** be iaw the Flight Information Service being provided ►⁵◀.

**Guidance
Material
3231(2)**

Controllers Responsibility for Terrain Clearance

6. Nil.

⁵ ► Refer to CAP 774 – UK Flight Information Services. ◀

RA 3232 – Provision of Vectors to Aircraft conducting Radar to Visual Recoveries or Short Pattern Circuits below the Air Traffic Control Unit Terrain Safe Level

Rationale

Radar to Visual recoveries (R-Vis) and Short Pattern Circuit (SPC) procedures may require Aircraft to be descended and vectored below the Air Traffic Control (ATC) Unit Terrain Safe Level. When Aircraft are deliberately descended below the ATC Unit Terrain Safe Level there exists a greater Risk of Controlled Flight into Terrain (CFIT). This RA details the Controller responsibilities regarding Air Traffic Service (ATS) provision below the ATC Unit Terrain Safe Level ▶ ◀.

Contents

3232(1): Provision of Vectors to Aircraft conducting Radar to Visual Recoveries or Short Pattern Circuits below the Air Traffic Control Unit Terrain Safe Level

Regulation 3232(1)

Provision of Vectors to Aircraft conducting Radar to Visual Recoveries or Short Pattern Circuits below the Air Traffic Control Unit Terrain Safe Level

3232(1) Controllers **shall** only provide vectors below the ATC Unit Terrain Safe Level when controlling Aircraft performing R-Vis or SPC ▶ **under receipt of a Traffic Service.** ◀

Acceptable Means of Compliance 3232(1)

Provision of Vectors to Aircraft conducting Radar to Visual Recoveries or Short Pattern Circuits below the Air Traffic Control Unit Terrain Safe Level

1. Controllers **should** only provide vectors to a maximum of 500 ft below the ATC Unit Terrain Safe Level, as depicted by the Radar Vector Chart (RVC) or Surveillance Minimum Altitude Area (SMAA), ▶ **excluding the Final Approach Vectoring Area (FAVA),** ◀ when:

- a. An Aircraft in receipt of a Traffic Service is performing a R-Vis recovery and is within 10 nautical miles (nm) of the Aerodrome.
- b. An Aircraft in receipt of a Traffic Service is performing a SPC or practice SPC and is within 10 nm of the Aerodrome.

▶ **Note:**

In these scenarios, the Controller is not required to make reference to responsibility for terrain clearance. ◀

2. ▶ ◀

3. Controllers **should not** provide vectors below the FAVA unless the Aircraft is established on a recognized instrument approach.

Guidance Material 3232(1)

Provision of Vectors to Aircraft conducting Radar to Visual Recoveries or Short Pattern Circuits below the Air Traffic Control Unit Terrain Safe Level

4. **RVC.** RVCs depict the lowest vectoring altitude ▶ ◀ / height in various sectors covering the normal operating range of the surveillance system. The altitudes / heights specified provide a minimum of 1000 ft obstacle clearance or 2000 ft in a mountainous ▶ **area**¹. ◀

¹ ▶ An area of changing terrain profile where the changes of terrain elevation exceed 3000 ft (900 m) within a distance of 10 nm (18.5 km). ◀

**Guidance
Material
3232(1)**

5. **Military Surveillance Minimum Altitude Chart (Mil SMAC).** Mil SMACs depict the lowest vectoring altitude¹ / height in various sectors covering the normal operating range of a military surveillance system. The minimum altitudes / heights available within the SMAA sectors are normally adequate to permit vectoring of an Aircraft to the final approach of a published Instrument Approach Procedure, including Surveillance Radar Approach. However, there may be circumstances where further descent below the SMAA, either on the final approach track, or while establishing on the final approach track, provides operational flexibility. The area that provides this facility is known as the FAVA. The altitudes / heights specified in the SMAA sectors provide a minimum of 984 ft (300 m), rounded up to the nearest 100 ft, to provide 1000 ft obstacle clearance including in a mountainous area¹. The altitudes / heights specified in the FAVA provide a minimum of 492 ft (150 m), rounded up to the nearest 100 ft, to provide 500 ft obstacle clearance².

² Refer to CAP 777 – ATC Surveillance Minimum Altitude Charts in UK Airspace Policy and Design Criteria.

RA 3233 - Conduct of Radar Handovers

Rationale

Controllers are required to use standard radar handover procedures to ensure the safe transfer of responsibility for Air Systems whilst ensuring accuracy of information and the avoidance of ambiguity.

Contents

3233(1): Conduct of Radar Handovers

Regulation 3233(1)

Conduct of Radar Handovers

3233(1) Radar handovers **shall** only be effected when specific requirements are met.

Acceptable Means of Compliance 3233(1)

Conduct of Radar Handovers

1. A radar handover **should** only be effected between 2 agencies when:
 - a. Satisfactory 2-way communication is possible.
 - b. Responsibility for the Air System is transferred directly from controller to controller.
 - c. The Air System is in an area of overlapping surveillance coverage¹.
 - d. The handover fulfils any standing agreement between the 2 agencies.
 - e. The releasing controller resolves any traffic conflicts before completing the handover.
2. Controllers **should** only conduct a handover in airspace in which they are authorized to provide an Air Traffic Service (ATS).

Guidance Material 3233(1)

Conduct of Radar Handovers

3. Controller to controller communication will be established in sufficient time before the arrival of the Air System at the handover point. The following information will be provided:
 - a. Console number or control position of the releasing controller.
 - b. Nature of task (eg VHF lower airspace transit) and callsign.
 - c. Position, heading / track or vectoring instructions. The releasing controller will allow the receiving controller to locate the radar return, say 'contact', and pass the new Secondary Surveillance Radar (SSR) transponder code for assignment by the releasing controller.
 - d. Flight level / altitude / height and flight conditions (if relevant).
 - e. Type of Air System.
 - f. Intentions (eg destination).
 - g. Any other relevant information (eg ATS, Reduced Vertical Separation Minima approval status).
4. The receiving controller will confirm receipt and understanding of the information by 'reading back'; additionally, the receiving unit's console number or control position will be passed to the releasing controller.
5. The receiving controller will confirm (or change if required) the ATS with the pilot on initial contact.
6. A shortened handover as defined in Command / Local Orders may be used in the case of pre-noted Air System.

¹ Throughout this RA, any reference to SSR is equally applicable to Wide Area Multilateration (WAM) and Automatic Dependant Surveillance Broadcast (ADS-B).

**Guidance
Material
3233(1)**

Transfer to International Agencies

7. Where direct communications exist between UK and Continental radar units they will be used for handovers in accordance with (iaw) relevant letters of agreement. When no such communications are available, the Air System will be released at a suitable time and position within the UK Flight Information Region (FIR) or UK Upper Information Region (UIR) to call the appropriate agency for clearance to enter the Continental FIR / UIR. In this case, the pilot will be advised that the ATS will be discontinued until Radiotelephony (RT) communication is re-established.

Silent Handovers

8. The procedure to be followed when carrying out silent handovers will vary according to the characteristics of the data communication system in use. Where such a system is authorized for this purpose, units will issue orders governing its use.

No Landline Communication Available

9. Although landline communication is normally used, where communication between the relevant ground agencies is not available the pilot will be given ► their ◀ position and instructed to 'Free Call' the next agency. The frequency to contact this agency will be passed whenever possible.

Radar Handover Methods- SSR

10. Controllers will use SSR to identify Air System whenever available.

11. When using SSR, the transfer of radar identity will accord with the following principles of operation:

- a. The receiving controller will state the SSR transponder code required.
- b. The handing-over controller will instruct the pilot to select the new transponder code.
- c. The remainder of the handover details will be passed.
- d. When the receiving controller agrees, the releasing controller will then pass the remaining instructions to the pilot to complete the handover.
- e. If it is not possible for the releasing controller to pass the change of SSR transponder code, or for the pilot to accept it, the taking over controller will pass the transponder code change as soon as possible after the handover is complete and prior to transferring to the receiving controller.

12. To avoid overloading pilots, particularly during the handover sequence, SSR transponder codes will not be included in the same RT message as changes of frequency, heading or level.

13. In situations where the SSR transponder code used in the transfer of identity is available for use by more than one Air System (eg, to indicate a particular task), the position report will be accurately defined iaw one or more of the methods detailed in RA 3227 ►² ◀.

Non SSR / WAM / ADS-B

14. If SSR / WAM / ADS-B is not available and the observed primary surveillance radar (PSR) response is consistent with the Air System reported track or heading, transfer of identity will be effected by one of the following methods:

- a. **Direct designation.** Direct designation (ie pointing) of the PSR return if the 2 surveillance displays are adjacent, or if a common 'conference' type of surveillance display is used, provided that:
 - (1) If the 2 surveillance displays are adjacent but the information is not derived from the same surveillance source, the transferring controller will ensure that the PSR returns on both displays correlate before indicating the position to the accepting controller.

² ► Refer to RA 3227 – Methods of Identification. ◀

**Guidance
Material
3233(1)**

(2) Caution is exercised because this method can be subject to parallax errors. If these errors are large, the method outlined at b below will be used.

b. **Designation of the PSR return as a bearing and distance from a common reference point.** Designation from a common reference point (eg navigational facility or geographical position) accurately indicated on both surveillance displays, provided that the position of the PSR return as seen by the receiving controller is within 3 nm of the position stated by the releasing controller. The manner in which the indication of the bearing of an Air System is determined and relayed will be subject to the following limitations on the permissible distance of the PSR return from the reference point as seen by the receiving controller:

- (1) By points of the compass (eg N; NNE; etc) ≤ 15 nm.
- (2) By a bearing estimated in degrees ≤ 30 nm.
- (3) By a bearing measured electronically in degrees ≤ 60 nm.

c. **Designation of the PSR return by reference to a GEOREF** video map, provided that the position of the PSR return, as seen by the receiving controller, is within 3 nm of the position stated by the releasing controller.

d. **Designation of the PSR return by positioning an electronic marker** or symbol so that only one PSR return is thereby indicated and there is no possible doubt of correct identification.

Radar Tracking System

15. Use of a radar tracking system where procedures are defined in Local / Unit Orders.

Flight Operations Assistant (FOA) Handovers

16. FOAs at RAF(U) Swanwick, operating in the role of Support Controller are authorized to carry out radar handovers to RAF, RN and USAF agencies within the UK FIR / UIR provided that:

- a. The FOA has been assessed by the Unit as being competent to carry out radar handovers.
- b. The FOA initiates a radar handover only when specifically instructed to do so by the controller.
- c. The FOA clearly identifies ► **their** ◀ role to the receiving agency.
- d. RAF(U) Swanwick, the receiving unit and the Air System have serviceable SSR equipment, and the AS is transponding the assigned code.
- e. Where an Air System is subject to prior coordination, the controller passes to the receiving controller details of the coordination to which the flight is subject.
- f. The receiving controller retains the right to insist on a controller-to-controller handover.
- g. The RAF(U) Swanwick controller retains overall responsibility for the handover.

Intentionally Blank for Print Pagination

RA 3234 – Air System Formations

Rationale

Due to the specific nature of Air System formations, they require additional procedures to ensure safe and efficient flight.

Contents

3234(1): Air System Formations

Regulation

3234(1)

Air System Formations

3234(1) A controller **shall** consider a formation as a single unit for controlling purposes when the formation is operating within specified parameters.

Acceptable Means of Compliance

3234(1)

Air System Formations

1. Formations **should** be considered as a single unit for separation purposes provided that:
 - a. The formation elements are contained within 1 nm laterally and longitudinally for military Air Systems or 0.5 nm laterally and longitudinally for civil Air Systems, and at the same level¹.
 - b. Where the formation contains a mix of military and civil Air Systems, the military distances (1 nm and at the same level) **should** be applied.
 - c. Where a civil formation is undertaking a military task, the formation **should** adopt the military formation distances (1 nm and at the same level).
 - d. Within Class G airspace only, at the controller's discretion, these limitations can be increased to 3 nm and / or up to 1000 ft vertically.
 - e. The formation, although operating outside the parameters given above, has been the subject of an Airspace Utilisation Section Airspace Coordination Notification (ACN) or tactical negotiation between appropriate military supervisors and civilian watch managers.
2. **► Within a formation of military Air Systems the formation leader **should** be responsible for separation between the elements comprising the formation; this is defined as Military Accepts Responsibility for Separation of Air Systems (MARSAs).**
3. **A formation operating under an Air Traffic Service (ATS) that wishes to operate beyond 3 nm and / or 1000 ft vertically in Class C and G airspace, (eg during Basic Fighter Manoeuvres or Close Air Support) **should** request non-standard formation status from the controller. Subject to the controller's approval, all formation elements **should** acknowledge the agreement and each Air System **should** squawk Mode 3A and C. In all circumstances, the controller will not provide traffic information between formation elements unless requested, or the controller considers it necessary in the interests of safety. ◀**

Guidance Material

3234(1)

Air System Formations

4. **► ◀**
5. In all classes of airspace **► when under an ATS, ◀ individual formation elements, except the lead Air System, ► may ◀ be instructed to squawk standby.**
6. When controlling a formation, controllers will identify the number of formation elements in handovers, requests for Cleared Flight Path, verbal coordination or when passing Traffic Information on landline or on Radiotelephony (RT).

¹ At the same level is defined as operating within 100 ft vertically of the lead Air System.

**Guidance
Material
3234(1)**

7. All Air Systems will fly at the same level; where this is not possible formations will be split into elements separated by the prescribed Air Traffic Control (ATC) separation minima, in accordance with (iaw) RA 3228², Separation Standards, before entering Controlled Airspace (CAS). Such elements may be either individual Air Systems or smaller formations that can fly within 1 nm (military) / 0.5 nm (civil) laterally and longitudinally and at the same level. Each element will be assigned a discrete Secondary Surveillance Radar (SSR)³ code.

8. Formations may be stepped-down vertically from the leader and can occupy more than one flight level. It is essential that the controller providing the service is aware of the flight levels blocked by the formation and ensures that, where applicable, it adheres to the Altitude Reservation (ALTRV) authorized in the Airspace Co-ordination Notice.

9. **United States Air Force Europe (USAFE) tanker formations.** If the climb to cruising level is stopped at an intermediate level, the formation will step-down at 500 ft levels from the leader. However, once cruising level is achieved, the formation will stack-up at 500 ft levels from the leader. Each element of the formation will be separated horizontally from the leader by 1 nm.

Formation Procedures Within CAS

10. Prior to a formation entering CAS, controllers will obtain confirmation on RT that all formation elements are contained within 1 nm laterally and longitudinally for military Air Systems or 0.5 nm laterally and longitudinally for civil Air Systems, and at the same level.

11. When a formation has been cleared to climb or descend in CAS, controllers will obtain confirmation that all elements have reached the assigned level. If the vacation of a level is relevant for the purposes of coordination, controllers will obtain confirmation that all elements have vacated the level.

12. When crossing CAS all elements in the formation will monitor the relevant ATC frequency.

13. **Formation Joins Within CAS.** Controllers will only permit a formation to join-up in CAS under the following circumstances:

- a. When an Air System has an emergency and a formation join-up is essential.
- b. Formations commencing a join-up prior to entering CAS are permitted to complete their join within CAS, when conditions allow, subject to maintaining standard separation from other Air Systems.
- c. Within Class C airspace, controllers can allow formations to join; however, they will give appropriate consideration to the formation's proximity to Upper Air Routes and other airspace users.
- d. All elements involved in a formation join will transpond Mode 3A and C until established in formation.

14. **Formation Splits Within CAS.** Controllers can permit formation splits in CAS giving due regard to other airspace users and coordination requirements.

Formation Procedures Outside CAS

15. A formation, with elements keeping station visually or by radar, of more than 1 nm length can receive an ATS outside CAS as follows:

- a. The lead Air System will squawk Mode 3A and C. If the stream extends for 3 nm or more, the last Air System will also squawk. For longer streams, intermediate Air Systems will squawk as appropriate.
- b. Flight Information Service (FIS) will be given to the lead Air System only.

² Refer to RA 3228 – Separation Standards.

³ Throughout this RA, any reference to SSR is equally applicable to Wide Area Multilateration and Automatic Dependant Surveillance Broadcast.

**Guidance
Material
3234(1)**

c. Controllers will identify the full extent of the stream formation during radar handovers, when effecting Coordination and passing Traffic Information to other controllers.

16. **Formation Join-up Procedures.** Formation join-up procedures will be as follows:

a. **Visual Meteorological Conditions (VMC).** Individual Air Systems can rendezvous, either by ground controlled vectors, or by internal aids, with the final join-up being made visually. The initial minimum vertical separation will be 2000 ft below the formation, but if the pilot is not visual with the formation when established in trail, vertical separation can be reduced to 1000 ft below with the agreement of both the formation leader and the pilot of the joining Air System. From this position, with the consent of the formation leader, the Air System can be cleared to climb visually and join the formation. From this point the formation leader is responsible for separation (MARSAs) between the units and the controller will address ►their◄ instructions only to the formation leader.

b. **Instrument Meteorological Conditions (IMC).** When, for operational reasons, IMC join-ups are essential, the following procedures will be applied:

(1) The initial phase of the join-up will be achieved either by ground controlled vectors or by use of Air System internal aids to a point no less than 5 nm horizontally from the formation leader and within 2000 ft vertically.

(2) At this point the position of the joining Air System will be passed to the formation leader and confirmation obtained that ►they are◄ willing to assume responsibility for separation between ►their◄ Air System, the Air System comprising the formation and the joining Air System. From this point MARSAs applies.

(3) The final join-up will be completed using Air System internal aids under the direction of the formation leader. The joining Air System will squawk standby when the join-up is complete.

17. **Formation split procedures.** Formation splits will be carried out by one controlling agency only. Handover of control to another ATS provider will not be attempted until the formation split has been completed.

18. **Achieving Vertical Separation.** The controller will agree with the formation leader whether individual Air Systems will be climbing to a level⁴ above, or descending to a level below, the formation level to achieve standard vertical separation, iaw RA 3228►²◄. With the approval of the controller, individual Air Systems can depart the formation visually in the pre-notified sequence on the instructions of the formation leader and climb or descend to the assigned level. The controller ►will◄ confirm that an Air System is established at its assigned flight level, identified and placed under an ATS, before authorizing the formation leader to instruct the next Air System to depart the formation.

19. **Applying Vectors.** The controller will agree with the formation leader the vectors that individual Air Systems will follow when departing the formation to achieve standard horizontal separation, iaw RA 3228►²◄. With the approval of the controller, individual Air Systems can depart the formation visually, in the pre-notified sequence, on the instructions of the formation leader, maintaining the assigned level and flying the agreed vector. When standard separation has been achieved, the controller must identify the Air System iaw RA 3227►⁵◄ and place it under an ATS before authorizing the formation leader to instruct the next Air System to depart the formation.

20. **Station Keeping Equipment (SKE) Formations.** C130 SKE formations will only be exempted from the requirements of paragraph 1 when:

- a. Lead and tail Air Systems are squawking (with Mode C).
- b. The flight is operating iaw a relevant ACN.

⁴ In the context of this RA, level may be used to refer to flight level, altitude or height.

⁵ ►Refer to RA 3227 – Methods of Identification.◄

**Guidance
Material
3234(1)**

c. Prior to the formation entering CAS, the controller has obtained a confirmation on RT that all elements are at the assigned level.

21. With the exception of paragraph ►20◀, formations subject to ACN action (eg Coronet Flights) or tactical negotiation between appropriate military supervisors and civilian watch managers use best practice (eg first and last Air Systems squawking), together with positive confirmation to ATC that all Air Systems are established in the assigned level block.

RA 3235 – Airborne Collision Avoidance Systems ► and Terrain Awareness and Warning Systems ◀ - Controller Responsibilities

Rationale

► Airborne Collision Avoidance Systems (ACAS) and Terrain Awareness and Warning Systems (TAWS) are fitted to Aircraft to reduce the Risk of mid-air collision or Controlled Flight into Terrain (CFIT) respectively. Inappropriate instructions to an Aircraft manoeuvring in response to an ACAS Resolution Advisory or TAWS warning could increase Risk to Life. Controllers therefore need to understand their responsibilities and actions when a pilot reports that they are manoeuvring in accordance with (iaw) an ACAS Resolution Advisory or TAWS warning. ◀

Contents

3235(1): Airborne Collision Avoidance Systems – Controller Responsibilities

► 3235(2): Terrain Awareness and Warning Systems – Controller Responsibilities ◀

Regulation 3235(1)

Airborne Collision Avoidance Systems – Controller Responsibilities

3235(1) Controllers **shall** cease to issue control instructions that are contradictory on being informed that an ► Aircraft ◀ is manoeuvring iaw an ACAS generated Resolution Advisory ► ◀.

Acceptable Means of Compliance 3235(1)

Airborne Collision Avoidance Systems – Controller Responsibilities

1. When a pilot reports that they are manoeuvring ► iaw ◀ an ACAS Resolution Advisory, Controllers **should** cease to provide instructions which would modify the ► Aircraft's ◀ flight path until the pilot reports "Clear of Conflict".
2. The Controller **should** resume responsibility for providing separation for all ► Aircraft ◀ affected by the Resolution Advisory when:
 - a. The Controller acknowledges a report from the pilot that the ► Aircraft ◀ has resumed the current Air Traffic Control (ATC) clearance; or
 - b. The Controller acknowledges a report from the pilot that the ► Aircraft ◀ is resuming the current ATC clearance and issues an alternative clearance which is acknowledged by the pilot.
3. Controllers **should not** routinely pass traffic information to ► Aircraft ◀ conducting Resolution Advisory manoeuvres, or other ► Aircraft ◀ affected by such manoeuvres.

Guidance Material 3235(1)

Airborne Collision Avoidance Systems – Controller Responsibilities

4. Once an ► Aircraft ◀ departs from an ATC clearance in compliance with a Resolution Advisory, or a pilot reports ► a ◀ Resolution Advisory, the Controller ceases to be responsible for providing separation between that ► Aircraft ◀ and any other ► Aircraft ◀ affected as a direct consequence of the manoeuvre as they may unknowingly issue instructions ► which ◀ conflict with the Resolution Advisory ► ◀.
5. There may be circumstances where the passing of traffic information is justified; consequently, controllers may provide traffic information under the following circumstances:

**Guidance
Material
3235(1)**

- a. To ► **Aircraft** ◀ conducting a Resolution Advisory manoeuvre if it is considered essential for Flight Safety (eg information on ► **Aircraft** ◀ which are known to be in close proximity that are not transponding Mode C information).
 - b. To other ► **Aircraft** ◀ affected by a Resolution Advisory manoeuvre if judged necessary by the controller (eg in airspace where the carriage and operation of ACAS and / or Secondary Surveillance Radar transponders is not mandatory).
6. Specific ACAS Resolution Advisory phraseology is detailed in CAP 413¹◀.

**Regulation
3235(2)**

► Terrain Awareness and Warning Systems – Controller Responsibilities

- 3235(2) Controllers **shall** cease to issue control instructions that are contradictory on being informed that an Aircraft is climbing iaw a TAWS warning².

**Acceptable
Means of
Compliance
3235(2)**

Terrain Awareness and Warning Systems – Controller Responsibilities

7. When a pilot reports that they are climbing iaw a TAWS warning, the controller **should** acknowledge the message and pass the appropriate pressure setting (QFE, QNH or Regional Pressure Setting).
8. Controllers **should not** dissuade a pilot from climbing.
9. Controllers **should not** routinely pass traffic information to Aircraft conducting a TAWS climb unless it is considered essential to mitigate an actual or perceived Risk of collision.
10. When an Aircraft subject to a TAWS warning is in conflict with another Aircraft, traffic information **should** be provided as follows:
 - a. Traffic information **should** be passed first to Aircraft in conflict with the Aircraft that is known or appears to be responding to a TAWS warning.
 - b. Traffic information **should** then be passed to the Aircraft responding to the TAWS warning once the Aircraft's Mode C / Mode S readout is observed to be at or above the appropriate Radar Vector Chart / Military Surveillance Minimum Altitude Chart altitude or, the pilot reports that they are no longer responding to a TAWS warning.

**Guidance
Material
3235(2)**

Terrain Awareness and Warning Systems – Controller Responsibilities

11. TAWS is a generic term that captures all equipment that assists a pilot to avoid CFIT such as, but not limited to:
 - a. Ground Proximity Warning System.
 - b. Enhanced Ground Proximity Warning System.
 - c. Ground Collision Avoidance System.
12. When responding to a TAWS warning, pilots will prioritise manually operating their Aircraft over informing ATC that they are manoeuvring iaw a warning.
13. When a TAWS warning instructs a pilot to climb, ACAS Resolution Advisories are temporarily suppressed. The suppressing of an ACAS Resolution Advisory only affects the Aircraft receiving the TAWS warning during the time the TAWS warning remains active. Other Aircraft in conflict that are suitably equipped and not receiving a TAWS warning may receive an ACAS Resolution Advisory.

¹ ► Refer to CAP 413 – Radiotelephony Manual.

² Refer to CAP 493 – Manual of Air Traffic Services – Part 1. ◀

**Guidance
Material
3235(2)**

14. Once an Aircraft departs from an ATC clearance in compliance with a TAWS warning, or a pilot reports responding to a TAWS warning, the Controller ceases to be responsible for providing separation between that Aircraft and any other Aircraft affected as a direct consequence of the manoeuvre as they may unknowingly issue instructions which conflict with the TAWS warning. Traffic information must be passed in accordance with paragraphs 9 and 10. ◀

Intentionally Blank for Print Pagination

RA 3236 – Clutter on Situational Displays

Rationale

Clutter on situational displays¹ may degrade their performance; however, there is a requirement for the continued provision of ATS.

Contents

3236(1): Clutter on Situational Displays

Regulation 3236(1)

Clutter on Situational Displays

3236(1) MOD Air Traffic Service Units (ATSU) **shall** plan for occasions when situational displays are affected by clutter.

Acceptable Means of Compliance 3236(1)

Clutter on Situational Displays

1. Where clutter of a long term or permanent nature is visible in a particular area, the impacts and potential mitigations **should** be assessed locally, utilizing extant Safety Management (SM) processes in accordance with **▶ RA 1020(3)². ◀**
2. Procedures detailing actions to be taken in the event of clutter on the situational display **should** be promulgated in Local / Unit Orders.
3. ATSU **should** establish formal mechanisms to communicate the procedures to deal with clutter on situational displays to Aviation Duty Holders and other airspace users.

Guidance Material 3236(1)

Clutter on Situational Displays

4. While not exhaustive, the factors listed below may be considered when developing procedures to deal with clutter on situational displays:
 - a. Surveillance Radar coverage of adjacent units in order to handover **▶ Aircraft ◀** being provided with an ATS.
 - b. The potential to deploy controllers to adjacent units.
 - c. Management of Instrument Flight Rules (IFR) procedures to mitigate the impact of areas where clutter affects the display.

Outside Controlled Airspace

5. In the event of clutter being present on the situational display controllers will consider the nature and extent of the clutter and, if necessary, take the following actions:
 - a. For **▶ Aircraft ◀** in receipt of a Deconfliction Service (DS), controllers will inform the pilot of the extent of the clutter and where practicable offer a reroute. The extent of such a reroute will, where possible, aim to achieve the planned lateral deconfliction minima from the observed clutter. However, it may still be necessary to reduce traffic information / deconfliction advice from the direction of the clutter.
 - b. For **▶ Aircraft ◀** in receipt of a Traffic Service (TS), and those **▶ Aircraft ◀** under a DS that are not rerouted, controllers will inform pilots of a reduction in traffic information / deconfliction advice. If the controller cannot maintain **▶ Aircraft ◀** identity, the service may be terminated or a Basic Service (BS) may be offered.
 - c. For all surveillance services, in order to maintain track identity of **▶ Aircraft ◀** being vectored to final approach, if re-routing around the clutter is not practicable for the reasons specified above, an alternative type of approach may need to be conducted.

¹ In this context a situational display may be a radar, surveillance or other display screen utilized for the provision of an Air Traffic Services (ATS).

² **▶ Refer to RA 1020(3): Responsibilities of Aviation Duty Holder-Facing Organizations. ◀**

**Guidance
Material
3236(1)****Inside Controlled Airspace**

6. In the event of clutter being present on the situational display the radar service may be limited; however, the ATS will not be unilaterally terminated. The controller may vector the ► Aircraft ◀ around the clutter; however, this might not be practicable due to traffic density, airspace availability and / or the requirement to follow specific arrival or departure tracks.

7. Controllers will consider the extent of the clutter and, if the intensity of the clutter is such that the controller is not able to clearly see the ► Aircraft ◀ Primary Surveillance Radar or Secondary Surveillance Radar position symbol, radar separation will not be used to separate it and other controlled ► Aircraft ◀.

8. The controller remains responsible for providing separation from ► Aircraft ◀ that are considered to be infringing controlled airspace. Therefore, the controller ► will ◀ consider the nature of the clutter including any observed movement, relative speed and track consistency, and take appropriate action if it is considered to be an unknown ► Aircraft ◀.

Radar Approaches In all Classes of Airspace

9. In addition to the procedures above, in all classes of airspace, for ► Aircraft ◀ intending to make a radar approach, the controller will assess the nature and extent of the clutter and decide whether:

- a. A radar approach is not possible owing to clutter, in which case the controller will inform the pilot; or
- b. A radar approach could be carried out, but there may be a possibility of radar contact being lost. In this case the controller will inform the pilot as early as possible that clutter is affecting ► the ◀ display and that missed approach instructions will be passed in good time if it becomes necessary to abandon the approach.

RA 3237 – Royal Low Level Corridors

Rationale

Members of The Royal Family afforded such status by the ► **Head** ◄ of Royal Travel, The Royal Household¹ are routinely flown in the UK by Royal Helicopter². The dynamic nature of military low flying may constitute a Hazard to the safe conduct of Royal Helicopter flights; therefore, Royal Helicopter flights are conducted within the confines of a Royal Low Level Corridor (RLLC)³ which are subject to specific conditions to ensure that adequate separation is achieved between Military ► **Aircraft**⁴ ◄ and the Royal Helicopter.

Contents

3237(1): Royal Low Level Corridors

Regulation 3237(1)

Royal Low Level Corridors

3237(1) Heads of Establishment, Aviation Duty Holders (ADHs), Accountable Managers (Military Flying) and ADH-Facing organizations **shall** ensure that Military ► **Aircraft**⁴ ◄ maintain adequate separation from Royal Helicopter flights.

Acceptable Means of Compliance 3237(1)

Royal Low Level Corridors

1. **Air Traffic Services (ATS)**. Prior to entering, and when operating inside RLLCs, Controllers and ► **Aircraft** ◄ operators **should** ensure that the Military ► **Aircraft** ◄ is in receipt of an ATS (either under Visual Flight Rules (VFR) or Instrument Flight Rules (IFR)) from:
 - a. The same Air Traffic Control (ATC) unit that is controlling the Royal Helicopter, or;
 - b. Another ATC unit that has established radar contact with the Royal Helicopter, ► **or**;
 - c. **An ATC unit that has confirmed with the controlling authority that the Royal Helicopter is on the ground or otherwise not in the RLLC⁵.** ◄
2. **Separation ► Criteria** ◄. In addition to the ► **ATS** ◄ requirements of para 1, ► **lateral separation of 5 nm** ◄ **should** be applied between Military ► **Aircraft** ◄ and the Royal Helicopter, ► ◄ with the following exceptions:
 - a. ► **Military light Aircraft** ◄ and helicopters operating under VFR with an Indicated Air Speed (IAS) of 140 kt or less **should** be provided with sufficient traffic information to assist the ► **Aircraft** ◄ operator to ► **remain** ◄ clear of the Royal Helicopter, or;
 - b. ► **Military Aircraft operating with an IAS greater than** ◄ 140 kts ► **should** only reduce lateral separation to 3 nm, subject to compliance with RA 3228(1)⁶ and when approved by ◄ the Royal Helicopter Commander.

¹ When so directed by the Civil Aviation Authority (CAA) ► **Group Director, Safety & Airspace Regulation Group (GD SARG)** or ◄ Head of Airspace, Aerodromes and Air Traffic Management (Hd AAA), certain flights within UK airspace by ► **reigning** ◄ Sovereigns and Heads of State of foreign countries and, where appropriate, Prime Ministers of Commonwealth countries may also be afforded Royal Flight status.

² Helicopters from The ► **King's** ◄ Helicopter Flight ► (TKHF), ◄ 32 (The Royal) Squadron and civilian chartered helicopters.

³ A RLLC is a series of check points and / or turning points promulgated by Notification message and / or Notice to Aviation. The CAA Airspace Regulation (Utilisation) is responsible for the coordination and notification of RLLC for Royal Helicopter flights.

⁴ ► **In the context of this RA, in addition to the MAA02: MAA Master Glossary definition of Military Aircraft, civil registered Aircraft being used for MOD tasks or activity are also included.**

⁵ The Notification message **should** include a list of nominated Aerodromes / agencies from which the Royal Helicopter expects to receive an ATS, from whom information may be sought regarding the location of the Royal Helicopter. Not being in radar contact at the expected time **should not** be accepted as a form of confirmation that the Royal Helicopter is not present in the RLLC.

⁶ Refer to RA 3228(1): Standard Separation – Lateral. ◄

**Guidance
Material
3237(1)****Royal Low Level Corridors**

3. ► RLLC are only applicable to Military Aircraft⁴.
4. Helicopters engaged on Royal Flight duties will squawk Mode 3A code 0037, regardless of whether or not an ATS is being provided; consequently, this code is to be treated as unvalidated and unverified. ◀
5. Additional guidance material can be found in the UK Aeronautical Information Publication (AIP) ENR 1.1 paragraph 4.4 Royal Flights.

RA 3239 – ► Aircraft ◀ Conducting Transits to / from Ships and Aerodromes

Rationale

There are specific communication and operating requirements for ► Aircraft ◀ conducting transits to / from ships and Aerodromes. ► Without appropriate notification and procedures there is a Risk Aircraft may not subsequently be able to make an unplanned return to the departure point in the event of an Aircraft emergency and / or weather. This Regulatory Article sets out the requirement for ships and Aerodromes to notify other agencies, and for staying open / at flying stations, when Aircraft are in transit between locations. ◀

Contents

3239(1): Departure Messages
3239(2): Operating Requirements

Regulation 3239(1)

Departure Messages

3239(1) Units **shall** send appropriate Air Traffic Service (ATS) Messages on behalf of ► Aircraft conducting ◀ transits to / from ships and Aerodromes.

Acceptable Means of Compliance 3239(1)

Departure Messages

1. When an ► Aircraft ◀ departs an Aerodrome or ship, a departure message **should** be sent to the point of destination. An arrival message **should** be sent to the point of departure on the arrival of an ► Aircraft ◀ transiting to / from a ship.

Guidance Material 3239(1)

Departure Messages

2. Nil.

Regulation 3239(2)

Operating Requirements

3239(2) Aerodromes **shall** remain open to meet the specific requirements of ► Aircraft ◀ conducting transits to / from ships and Aerodromes.

Acceptable Means of Compliance 3239(2)

Operating Requirements

3. When an ► Aircraft ◀ is on a transit flight from an Aerodrome to a ship, the Aerodrome **should** remain open until in receipt of an arrival message for that ► Aircraft ◀ or with the agreement of the ► Aircraft ◀ Commander to close. When an ► Aircraft ◀ is on a transit flight from a ship to an Aerodrome, the ship **should** remain at flying stations until receipt of an arrival message for that ► Aircraft ◀ or with the agreement of the ► Aircraft ◀ Commander to fall out from flying stations.

Guidance Material 3239(2)

Operating Requirements

4. Nil.

Intentionally Blank for Print Pagination

RA 3240 – Contingency Operations for Simultaneous Failure of Surveillance Radars and / or Air Traffic Management Communication Systems

Rationale

The provision of Primary Surveillance Radar (PSR), Secondary Surveillance Radar (SSR)¹ and / or Air Traffic Management (ATM) communication systems are integral to providing Military ATM. The simultaneous failure of PSR, SSR and ATM communication systems may introduce hazards which have an impact on the Risk to Life (RtL) to Air Systems that are reliant on ATM provision. Heads of Establishment (HoE) and Aviation Duty Holder (ADH)-Facing organizations require contingency arrangements to continue to provide Air Traffic Services (ATS) and assist ADHs in ensuring the RtL associated with equipment failures is As Low As Reasonably Practicable and Tolerable.

Contents

3240(1): Surveillance Radar and Air Traffic Management Communications Contingency Operations

3240(2): Withdrawn – Detail in RA 1020²

Regulation 3240(1)

Surveillance Radar and Air Traffic Management Communications Contingency Operations

3240(1) HoEs and ADH-Facing organizations **shall** employ contingency operations for the simultaneous failure of PSR and SSR and / or ATM communications systems.

Acceptable Means of Compliance 3240(1)

Surveillance Radar and Air Traffic Management Communications Contingency Operations

1. HoEs and ADH-Facing organizations **should** assist ADHs by safety managing contingency operations in accordance with RA 1020(4)².
2. HoEs and ADH-Facing organizations **should** assist ADHs in mitigating the hazards associated with the simultaneous failure of PSR and SSR and / or communications systems through the production of contingency procedures.
3. Contingency procedures **should** be promulgated in Local / Unit Orders and **should** be captured in accordance with RA 1026³.
4. HoEs and ADH-Facing organizations **should**:
 - a. Establish formal mechanisms to ensure robust communication to ADHs and other airspace users of the contingency procedures and when they are in operation.
 - b. Inform adjacent Air Navigation Service providers and the Distress and Diversion Cell when contingency procedures are in operation.
 - c. Issue a Notice to Airmen advising of loss of PSR and SSR and / or ATM communications systems.

¹ ► Throughout this RA, any reference to SSR is equally applicable to Wide Area Multilateration and Automatic Dependant Surveillance Broadcast.

² Refer to RA 1020 (4): Responsibilities of Aviation Duty Holder-Facing Organizations.

³ Refer to ◀ RA 1026 – Aerodrome Operator ► and Aerodrome Supervisor (Recreational Flying) Roles and Responsibilities including Aerodrome and Helicopter Landing Site Assurance Requirements. ◀

**Guidance
Material
3240(1)**

**Surveillance Radar and Air Traffic Management Communications
Contingency Operations**

5. While not exhaustive, the factors listed below may be considered when developing contingency plans:
- a. The immediate actions that Controllers carry out in the event of simultaneous failure of PSR and SSR and / or communication systems.
 - b. Restricting the level of ATS available to a Basic Service only; however, even this level of ATS may not be appropriate in all situations.
 - c. Diverting Air Systems on recovery.
 - d. Surveillance Radar coverage of adjacent units in order to freecall Air Systems being provided with an ATS.
 - e. The potential to deploy controllers or Air Systems to other units.
 - f. Local airspace activities.
6. Controllers use two types of surveillance systems: PSR and SSR. PSR is the primary surveillance system employed by controllers for the control of Air Systems and is normally the minimum level of surveillance equipment required to provide a Radar Control, Deconfliction Service or Traffic Service. SSR is normally employed to assist in Air System identification and to establish the level⁴ of the Air System.
7. In the event of failure of both PSR and SSR, no Air System will be visible to the controller on the surveillance display. Consequently, controllers will be unable to provide a surveillance-based ATS to any Air System.

**Regulation
3240(2)**

Aviation Duty Holder Responsibilities

3240(2) Withdrawn – Detail in RA 1020.

**Acceptable
Means of
Compliance
3240(2)**

Aviation Duty Holder Responsibilities

8. Withdrawn – Detail in RA 1020.

**Guidance
Material
3240(2)**

Aviation Duty Holder Responsibilities

9. Nil.

⁴ Level is a general term which can be used to describe the Flight Level, Height or Altitude an Air System is operating at.

RA 3241 – Secondary Surveillance Radar Alone Operations

Rationale

The utilization of Primary Surveillance Radar (PSR) and Secondary Surveillance Radar (SSR)¹ provides the optimal surveillance coverage when providing Air Traffic Services (ATS). The temporary withdrawal of PSR due to failure or Maintenance, or where no PSR coverage exists, may introduce hazards such as the inability to warn Air System operators of non-transponding Air Systems. Heads of Establishment (HoE) and Aviation Duty Holder (ADH)-Facing organizations require SSR Alone procedures and dedicated contingency operations to ensure that ATS can continue to be provided in an SSR Alone environment to all Air Systems and to assist ADH's in ensuring the Risk to Life (RtL) is As Low As Reasonably Practical (ALARP) and Tolerable.

Contents

- 3241(1): Secondary Surveillance Radar Alone Operations
- 3241(2): Secondary Surveillance Radar Alone Contingency Operations
- 3241(3): Withdrawn – Detail in RA 1020²

Regulation 3241(1)

Secondary Surveillance Radar Alone Operations

3241(1) HoEs and ADH-Facing organizations **shall** ensure that in the event of PSR unavailability, UK Flight Information Services (FIS) and Radar Control Service (RCS) can continue to be provided utilizing SSR when requested by the Air System operator and agreed by the controller.

Acceptable Means of Compliance 3241(1)

Secondary Surveillance Radar Alone Operations

1. Where PSR is unavailable on either a permanent (where no PSR coverage exists eg certain areas within the Scottish Flight Information Region (FIR)) or temporary basis (eg following equipment failure or during periods of Maintenance), RCS and UK FIS **should** continue to be provided in accordance with (iaw) RA 3223³, RA 3224⁴, Civil Air Publication (CAP) 413 Radiotelephony Manual and CAP 774 UK FIS.
2. Within Class A, C, D and E Airspace, Class C Airways, Terminal Manoeuvring Areas, Terminal Control Areas, Control Areas and Transponder Mandatory Zones, SSR Alone ATS **should** only be provided where procedures are specifically authorized by Civil Aviation Authority (CAA) Safety and Airspace Regulation Group (Airspace Regulation) (SARG(AR)) and published within Unit Order Books or Standard Operating Procedures (SOP) as appropriate.

Guidance Material 3241(1)

Secondary Surveillance Radar Alone Operations

3. Controllers use two types of surveillance systems: PSR and SSR. PSR is the primary surveillance system employed by controllers for the control of Air Systems and is normally the minimum level of surveillance equipment required to provide a RCS, Deconfliction or Traffic Service. SSR is normally employed to assist in Air System identification and to establish the level⁵ of the Air System.
4. When operating SSR Alone, only transponding Air Systems will be visible to the controller on the surveillance display. Air Systems that are not equipped with a transponder, or where the transponder has not been selected to transmit will not be

¹ ► Throughout this RA, any reference to SSR is equally applicable to Wide Area Multilateration and Automatic Dependant Surveillance Broadcast.

² Refer to ◀ RA 1020 –► ◀ Aviation Duty Holder and Aviation Duty Holder-Facing Organizations –► Roles and Responsibilities. ◀

³ RA 3223 – Provision of Air Traffic Service Inside Control Controlled Airspace.

⁴ RA 3224 – ► UK ◀ Flight Information Services ► ◀.

⁵ Level is a general term which can be used to describe the Flight Level, Height or Altitude an air system is operating at.

**Guidance
Material
3241(1)**

displayed. Consequently, controllers will be unable to warn pilots of the proximity of non-transponding Air Systems.

5. The Aircraft Commander is ultimately responsible for the safety of their Air System, crew and passengers. Although they may not be the handling pilot, it is vital that they understand any increased RtL associated with operating in an SSR Alone environment and that they take the appropriate action to ensure the safety of the flight, specifically with regard to avoidance of mid-air collisions (MAC).

**Regulation
3241(2)**

Secondary Surveillance Radar Alone Contingency Operations
3241(2) HoEs and ADH-Facing organizations **shall** employ contingency operations when SSR Alone operations are required in order to minimize the exposure of ADH Air Systems and other airspace users to the SSR Alone environment.

**Acceptable
Means of
Compliance
3241(2)**

Secondary Surveillance Radar Alone Contingency Operations

6. The planned or unplanned withdrawal of a surveillance system is a significant safety related change and removes a barrier associated with the prevention of MAC. HoEs and ADH-Facing organizations **should** assist ADHs through safety managing SSR Alone ATS provision iaw RA 1020(4)⁶◀. The loss of PSR will either result from equipment failure or planned Maintenance. HoEs and ADH-Facing organizations **should** assist ADHs in mitigating the hazards associated with the loss of PSR through the production of procedures that address:

- a. Contingency (equipment failure).
- b. Planned withdrawal (eg Maintenance schedules).

7. SSR Alone operating procedures **should** be promulgated in Local / Unit Orders or SOPs (these procedures **should** be captured iaw RA 1026⁷).

8. HoEs and ADH-Facing organizations **should**:

- a. Establish formal mechanisms to ensure robust communication to ADHs and other airspace users of the procedures associated with equipment failure or the planned withdrawal of PSR.
- b. Inform adjacent air navigation service providers and the Distress and Diversion Cell when operating SSR Alone.
- c. Issue a Notice to Airmen advising of loss of PSR.
- d. Inform Air System operators prior to transfer (handover or freecall) if the receiving unit is operating SSR Alone.

**Guidance
Material
3241(2)**

Secondary Surveillance Radar Alone Contingency Operations

9. While not exhaustive, the factors listed below may be considered when developing SSR Alone procedures:

- a. Surveillance Radar coverage of adjacent units in order to handover Air System being provided with an ATS.
- b. The potential to deploy controllers to adjacent units.
- c. Local airspace activities.
- d. Agreements with local aerodrome and airspace activity providers (eg parachuting or paragliding organizations).
- e. Management of Instrument Flight Rules (IFR) procedures to mitigate the impact of hazardous areas (eg adjusting instrument procedures to avoid known gliding sites).

⁶ ▶ Refer to RA 1020(4): Responsibilities of Aviation Duty Holder-Facing Organizations.

⁷ Refer to ◀ RA 1026 – Aerodrome Operator ▶ and Aerodrome Supervisor (Recreational Flying) Roles and Responsibilities including Aerodrome and Helicopter Landing Site Assurance Requirements. ◀

**Guidance
Material
3241(2)**

- f. The scheduling of PSR Maintenance programmes.

**Regulation
3241(3)**

Aviation Duty Holder Responsibilities – Secondary Surveillance Radar Alone Operations
3241(3) Withdrawn – Detail in RA 1020.

**Acceptable
Means of
Compliance
3241(3)**

Aviation Duty Holder Responsibilities – Secondary Surveillance Radar Alone Operations
10. Withdrawn – Detail in RA 1020.

**Guidance
Material
3241(3)**

Aviation Duty Holder Responsibilities – Secondary Surveillance Radar Alone Operations
11. Nil.

Intentionally Blank for Print Pagination

RA 3261 - Aerodrome Service

Rationale

The Aerodrome environment may contain a complex mix of ► Aircraft, vehicles, and personnel, ◀ often operating in close proximity ► that require to be safely managed, controlled and, where necessary, assisted in an emergency. Without effective control procedures and management of Aerodrome assets, Aerodrome users may be exposed to increased Risk of harm. It is therefore essential that an Aerodrome Service is correctly provided to enable ◀ the safe separation and effective operation of Aircraft, vehicles, and ► personnel ◀ on the Movement Area and ► ◀ in the vicinity of the Aerodrome ► while also enabling an effective emergency response when required. ◀

Contents

3261(1): Aerodrome Service

3261(2): Aerodrome Emergency Services

3261(3): Aerodrome Service in Class D Airspace

Regulation 3261(1)

Aerodrome Service

3261(1) ► **Head of** ◀ Aviation Duty Holders-Facing Organizations ► **and Accountable Manager (Military Flying)-Facing Organizations (AA-Facing Organizations)** and ◀ **Heads of Establishment (HoE)** **shall** provide an Aerodrome Service at Aerodromes for which they are responsible ► ◀.

Acceptable Means of Compliance 3261(1)

Aerodrome Service

1. Controllers providing an Aerodrome Service **should** issue information and instructions to Aircraft to achieve a safe, orderly and expeditious flow of air traffic in order to assist in preventing collisions between:
 - a. Aircraft on the Manoeuvring Area.
 - b. Aircraft and obstructions on the Manoeuvring Area.
 - c. Aircraft landing and taking off.
 - d. Aircraft flying within the ► **visual** ◀ circuit ► **and in the vicinity of the Aerodrome Traffic Zone (ATZ).** ◀
2. All instructions passed to Aircraft, vehicles and personnel on the Movement Area by ► **Air Traffic Control (ATC) personnel,** ◀ **should** be considered as mandatory ► ◀.
3. **Aerodrome Service Provision.** Controllers providing an Aerodrome Service **should,** as a minimum:
 - a. Alert and dispatch ► **Aerodrome Emergency Services**^{1,2.} ◀
 - b. Sequence Visual Flight Rules (VFR) traffic flying in the ► **visual** ◀ circuit and all movements of Aircraft on the Manoeuvring Area.
 - c. Sequence the mixed arrival and departure of visual and instrument traffic.
 - d. Notify changes to Aerodrome Crash Category.
 - e. Control ► **Aircraft,** ◀ vehicles and ► **personnel** ◀ on the Movement Area.
 - f. Provide an Alerting Service.
 - g. Monitor wind speed and direction.
 - h. Notify Aerodrome unserviceability or work in progress.
 - i. Warn Aircraft of other Aircraft conducting ground runs.

¹ ► Aerodrome Emergency Services includes Aerodrome Rescue and Fire Fighting (ARFF) and Aerodrome Emergency Medical Services.

² For the States of Readiness for Aircraft Emergencies refer to Manual of Military Air Traffic Management (MMATM): Chapter 5 – Emergency Procedures. ◀

**Acceptable
Means of
Compliance
3261(1)**

- j. Warn of significant changes in meteorological (Met) conditions.
 - k. Notify Runway surface conditions.
 - l. Warn of wildlife Hazards.
 - m. Notify Runway changes.
 - n. Notify configuration of Aerodrome Arresting Systems.
 - o. Oversee the application of Low Visibility Procedures (LVP), where applicable, in accordance with (iaw) RA 3274³.
 - p. Apply Local ►◄ specific Orders, eg, noise abatement procedures.
 - q. ► Take overdue action iaw RA 3312⁴.
 - r. Apply Wake Turbulence separation iaw RA 3277⁵.
4. The Aerodrome Controller (ADC) and relevant radar Controller **should** manage the safe and expeditious flow of VFR / Instrument Flight Rules (IFR) arrivals and departures, and traffic routing in close proximity to the visual circuit, including appropriate clearances as required. Where necessary, local procedures for integrating Aircraft in the vicinity of the Aerodrome **should** be detailed in local orders.
5. The point at which the control of arriving and departing Aircraft is transferred between Controllers **should** be managed in order to maximize Safety and aid expedition, having considered the Met conditions, standard approach and departure procedures, traffic picture and any relevant local procedures. ◄
6. ►◄
- a. ►◄
 - b. ►◄
7. **Traffic Information (TI) and Instructions.** TI and instructions **should** be passed to Aircraft on any occasion that a Controller considers it necessary in the interests of Safety, or when requested by the pilot. In particular, an Aerodrome Service **should** provide:
- a. Generic TI to enable VFR pilots to safely integrate their flight with other Aircraft; (eg number of Aircraft in the visual circuit).
 - b. Specific TI appropriate to the stage of flight and Risk of collision; (eg circuit positions of Aircraft passed to Aircraft calling at Initial).
 - c. Timely instructions as necessary to assist in the prevention of collisions and to enable safe, orderly and expeditious flight within and in the vicinity of the Military Aerodrome Traffic Zone (MATZ).
8. ►◄
9. **Met Information.** Where Met information is required, it **should** include:
- a. Surface wind direction (magnetic) and speed.
 - b. Visibility.
 - c. Present weather.
 - d. Cloud base and amount.
 - e. Altimeter pressure setting (QFE or QNH respectively).
10. Controllers **should** warn pilots of gusts or crosswinds:
- a. When the maximum wind speed ► exceeds ◄ the mean speed ► by 10 knots or more. ◄

³ Refer to RA 3274 – Low Visibility Procedures.

⁴ ► Refer to RA 3312 – Overdue Action by Air Traffic Control.

⁵ Refer to RA 3277 – Wake Turbulence. ◄

**Acceptable
Means of
Compliance
3261(1)**

- b. Prior to take-off and landing, reporting the extremes in direction and speed (gust and lull) during the past 10 minutes ►**law**◄ Civil Aviation Publication (CAP) 746⁶.
11. ►◄ **Automatic Terminal Information System (ATIS)**. Where ATIS is required, procedures **should** be established for its provision, delivery and content, ►**prior to its**◄ introduction and ►**when enduring changes are necessary**. **Relevant stakeholders should be engaged**◄ to ensure that any Hazards ►◄ are identified and appropriately mitigated.
12. Procedures **should** cover ►**as a minimum:**◄
- Use ►◄ of equipment employed in the provision of ATIS.
 - Means of delivery eg frequency allocation.
 - Mechanisms of delivery including:
 - Requirements ►**and process**◄ for initiating or updating ATIS messages.
 - ◄
 - Communication of updates to ATIS messages.
 - Responsibility for ATIS provision and delivery, and qualification of relevant personnel.
 - Content of message, including mechanisms for assuring the content of messages.
13. ►◄
14. **Essential Aerodrome Information**. ►**To ensure the safe operation of Aircraft, Controllers should inform the pilot at the earliest opportunity of any defects affecting**◄ the Movement Area ►**or any unserviceability of navigational aids and Aerodrome lighting**◄ that may constitute a Hazard. ►◄
15. ►◄
16. ►**Brake Chute Recovery**⁷. The recovery of a brake chute deployment **should only be carried out by a Suitably Qualified Experienced Person**.◄
17. **Runway Occupied**. When Aircraft, ►◄ vehicles ►**or personnel**◄ have been given permission to cross or occupy a Runway in use, the ADC **should** display a strip(s) or marker(s) on the part of the flight progress board that is used to represent the Runway as a positive reminder that the Runway is occupied.
18. **Traffic Lights**. ►**The ADC is responsible for the operation of traffic lights to**◄ control ►◄ vehicles, ►**cyclists and pedestrians, but may delegate operation of them to appropriate personnel**. Traffic lights **should** be operated to ensure that the◄ red ►**light**◄ signal is displayed in ►◄ time ►**for individuals**◄ to observe and obey the instruction.
19. **Jet Blast**⁸. Prior to a Controller◄ issuing instructions and clearances ►**to an Aircraft, where relevant,**◄ the Hazards of jet blast ►**should be taken into account**.◄ Particular care ►**should**◄ be taken when multiple line-up instructions are issued and Aircraft ►**could**◄ be subjected to the jet blast ►◄ from preceding departures.
20. **Persons On Board (POB)**. The ADC / Ground ►**Controller**◄ **should** ascertain POB, at the earliest of:
- Initial contact.
 - Before issuing a clearance to taxi.
 - Before issuing a clearance to take-off.
 - Other times as ►**specified**◄ in Local ►◄ Orders.

⁶ Refer to CAP 746 - Requirements for Meteorological Observations At Aerodromes.

⁷ ►Refer to MMATM Chapter 5: Emergency Actions and Procedures – Brake Chute Operations.

⁸ Additional information on 'Heavy Aircraft Jet Exhaust' is contained in MMATM Chapter 2: Air Traffic Control Procedures.◄

**Acceptable
Means of
Compliance
3261(1)**

21. **Taxiing Aircraft.** When the pilot of an Aircraft requires start-up or taxi clearance, the following information **should** be given ▶◀:
- Runway in use.
 - Surface wind direction and speed, including significant variations.
 - Aerodrome QFE or QNH, as appropriate.
 - Outside air temperature.
 - Significant Met conditions ▶◀.
22. **Taxi instructions.** ▶◀ Taxi instructions ▶ **should be issued to** ◀ a ▶ **specific** ◀ point ▶ **on the Manoeuvring Area or Apron** ◀ at which the Aircraft **should** stop, unless further permission to proceed is given. ▶◀
23. When clearing an Aircraft to the holding point of the Runway in use ▶ **and the intention is to permit the Aircraft to cross an additional Runway, whether active or not, the taxi clearance** ◀ **should** contain an explicit clearance to cross that Runway. If such a clearance cannot be given, the clearance limit, ▶ **with instructions to hold at a specific point, should exclude reference to a runway or route beyond it.** ◀
24. **Runway Clearance.** Prior to issuing any permission / clearance to use the Runway, the ADC **should** perform a final check ▶ **to confirm that the Runway is clear of obstructions, traffic** ◀ lights and ▶ **arrestor systems are correctly configured and that any other required conditions are met** ◀ iaw Local ▶◀ Orders and instructions.
25. When multiple Runways are in use and possibility of confusion exists, the clearance **should** include the ▶ **applicable Runway** ◀ designator ▶◀.
26. **Line-Up Instruction.** Local ▶◀ Orders **should** define situations in which more than one Aircraft may be permitted to line-up.
27. **Departure Clearance.** If an ATC clearance could be confused with a taxi instruction, to avoid pilots taking-off without a take-off clearance, it **should** commence with the phrase 'after departure' to ensure clarity.
28. An Aircraft on an IFR flight **should not** be given take-off clearance until:
- The ATC clearance, if required, has been passed and acknowledged by the pilot, and;
 - The ▶ **relevant radar** ◀ Controller has authorized departure and any specific instructions have been passed to the Aircraft.
29. **Take-off Clearance.** The ADC **should** issue take-off clearances and advise pilots of the surface wind or other significant Met conditions.
30. A take-off clearance **should** be issued separately from any other clearance message.
31. If an Aircraft is lined up on the Runway and a revised clearance or post departure instructions need to be passed, the revised clearance or post departure instructions **should** be prefixed with an instruction to 'hold position'.
32. An Aircraft ▶ **or Aircraft formation** ◀ **should not** be permitted to begin take-off until the preceding ▶ **departing** ◀ Aircraft is observed to be airborne or has reported 'airborne' by radiotelephony (RTF) and all preceding landing Aircraft have vacated the Runway in use, ▶ **ensuring the appropriate wake turbulence⁵ separation is applied.** ◀
33. A departing Aircraft **should not** be given control instructions which would require it to make a turn before it has reached a height / altitude that places it above the Radar Vector Chart (RVC) / Surveillance Minimum Altitude Area (SMAA) if using a Military Surveillance Minimum Altitude Chart (Mil SMAC) unless remaining below the Unit Terrain Safe Level iaw RA 3231⁹ ▶◀.
34. ▶ **Expedition.** Where there is a requirement for the ADC to be expeditious the following instruction 'cleared for immediate take-off, iaw CAP 413'¹⁰, **should** be issued to the pilot who will respond accordingly:

⁹ Refer to RA 3231 – Terrain Safe Level and Terrain Clearance.

¹⁰ ▶ Refer to CAP 413 - Radiotelephony Manual, Chapter 4 – Aerodrome Phraseology. ◀

Acceptable Means of Compliance 3261(1)

- a. At the holding point, taxi immediately to the Runway and commence take-off without stopping the Aircraft.
- b. If already lined-up on the Runway, take-off without delay.
- c. If an immediate take-off is not possible, they will advise the ADC.

35. **Cancelling take-off Clearances.** If a take-off clearance has to be cancelled before the take-off run has commenced, the pilot **should** be instructed to 'hold position' and to acknowledge the instruction. If, after the Aircraft has commenced take-off, an issue is identified the ADC **should** notify the pilot, ► **aw** ◀ CAP 413¹⁰.

36. **Landing.** When Aircraft are using the same Runway, a landing Aircraft **should** only be permitted to touch down before the preceding landing Aircraft has vacated the Runway if this is ► **authorized** ◀ in Local ► ◀ Orders.

37. **Instructions to Aircraft in the Final Stages of Approaching to Land.** With the exception of instructions to go-around, the ADC **should not** issue instructions to Aircraft in the final stages of approaching to land that would require it to deviate from its expected flight path unless exceptional and overriding Safety considerations apply.

38. ► **Gear Checks.** Clearance to use a Runway, for Aircraft with retractable landing gear, **should** only be issued after a positive gear check has been received from the pilot. The only exception to this is for Tilt Rotor Aircraft operating in the visual circuit who **should** be issued the clearance, 'with your gear down' as they are unable to lower their gear until short finals. ◀

39. **Low Approach Restrictions.** If the Runway in use is occupied by an Aircraft, ► **vehicles or personnel**, ◀ an approaching Aircraft that has requested a low approach or a touch and go, **should** only be cleared to carry out a low approach, restricted to a height not below that ► **specified** ◀ in Local ► ◀ Orders. In such circumstances, the pilot **should** be informed of the Aircraft, ► **vehicles or personnel** ◀ on the Runway. Additionally, the Aircraft, ► **vehicle or personnel** ◀ on the Runway **should** be informed of the Aircraft carrying out the low approach.

40. ► ◀

- a. ► ◀
- b. ► ◀
- c. ► ◀

41. ► **Light** ◀ and **Pyrotechnic Signals.** The standard ► **light** ◀ and pyrotechnic signals in Table 1 **should** be used in the control of Aircraft, where necessary.

Table 1. ► **Light** ◀ and **Pyrotechnic Signals**

| Characteristic and Colour of Light Beam or Pyrotechnic | From ATC to an Aircraft in flight | From ATC to an Aircraft on the ground |
|--|---|---------------------------------------|
| Steady Red Light ► or Red flare ◀ | Go Around | Stop |
| Red Flashes ► ¹¹ ◀ | Total refusal of permission to land | Move clear of landing area |
| Steady Green Light ► or Green flare ◀ | You may land | You may take-off |
| White Flashes ► ¹¹ ◀ | Land at this Aerodrome after receiving steady green light | Return to starting point |

42. ► The type of light and / or pyrotechnic signal in use at the Aerodrome, and where it is operated from¹², **should** be annotated in the Military Air Information Publication (AIP) or UK AIP, where applicable, to ensure that Aircrew know what type and where to expect the light and / or pyrotechnic signal to come from. ◀

¹¹ ► Only applicable to light signals.

¹² For example, from the ATC Tower, a remote light signal location or a Truck Runway Control (TRC) vehicle. ◀

**Acceptable
Means of
Compliance
3261(1)**

43. **Runway and Aerodrome Movement Area (AMA) Incursion**¹³. Controllers **should** remain vigilant to the possibility of a Runway and AMA Incursion by Aircraft, vehicle, person, animal or object. All Runway and AMA Incursions **should** be reported iaw RA 1410¹⁴, with the relevant boxes selected and specific mention of Runway or AMA Incursion in the title to aid analysis.

**Guidance
Material
3261(1)**

Aerodrome Service

44. **▶AA-Facing Organizations◀** and HoEs may elect to delegate some responsibilities incumbent of an ADC in the provision of an Aerodrome Service to the Ground Controller or other positions (such as the alerting and dispatch of ARFF and control of vehicles and **▶personnel◀** on the Movement Area) **▶◀**.

45. Essential Aerodrome Information (detailed in paragraph 14) may include **▶but not be limited to:◀**

- a. Construction work or maintenance on the Movement Area.
- b. Rough portions of the Movement Area and whether marked or not.
- c. Failure or irregular functioning of the Aerodrome lighting system.
- d. Failure or irregular functioning of approach aids.
- e. Aircraft parked close to Runways or taxiways and Aircraft engaged in ground running of engines.
- f. **▶Runway surface condition iaw RA 3272¹⁵.◀**
- g. In snow and ice conditions; information concerning sweeping and / or sanding of Runways and taxiways **▶iaw the Snow and Ice Control Plan¹⁶.◀**
- h. Bird formations or large birds reported or observed on or above the Movement Area or in the immediate vicinity of the Aerodrome and the extent of any bird dispersal action being carried out iaw RA 3270¹⁷.
- i. **▶◀**

46. **ATIS**. Guidance on the provision of ATIS can be found as follows:

- a. International Convention on Civil Aviation (ICAO) Annex 11 Air Traffic Services contains requirements for the provision and delivery of ATIS.
- b. Guidance material relating to Data link-ATIS (D-ATIS) is contained in ICAO Doc 9694 Manual of Air Traffic Services Data Link Applications. The technical requirements for the D-ATIS application are contained in ICAO Annex 10 Aeronautical Telecommunications, Volume III, Part I, Chapter 3.
- c. Civil Aviation Authority CAP 413¹⁰ contains requirements for the content of ATIS messages and guidance on transmitting technique.
- d. ICAO Annex 3 Meteorological Service for International Air Navigation contains guidance on the use of Met information.
- e. RA 3130¹⁸ regulates the use and Maintenance of ATM Equipment.

47. **Landing Direction and Runway in use**. **▶These terms refer to◀** the most suitable **▶Runway or landing direction selected by a Controller◀** at any particular time. **▶Typically they are◀** aligned to the surface wind direction, **▶but other factors such as traffic patterns, availability of approach aids and the length of Runway or landing run available may also be taken into consideration.◀**

48. Where the surface wind conditions are light and variable the 2000 ft wind will be taken into account before selecting the Runway in use. **▶◀** At certain Aerodromes more than one Runway may be in use at any one time.

¹³ Refer to MAA 02: MAA Master Glossary.

¹⁴ Refer to RA 1410 – Occurrence Reporting and Management.

¹⁵ **▶Refer to RA 3272 – Evaluation of Runway Surface Conditions.**

¹⁶ **Refer to RA 3278 – Snow and Ice Operations.◀**

¹⁷ Refer to RA 3270 – Aerodrome Wildlife Control.

¹⁸ Refer to RA 3130 – Air Traffic Management Equipment Safety Management.

**Guidance
Material
3261(1)**

49. **Traffic Patterns.** Details of Aerodrome traffic patterns may be found in North Atlantic Treaty Organization (NATO) Standardization Agreement (STANAG) 3297, NATO Standard Aerodrome and Heliport Air Traffic Service (ATS) Procedures¹⁹.

**Regulation
3261(2)**

Aerodrome Emergency Services

3261(2) ▶ **Head of AA-Facing** ◀ Organizations and HoE **shall** provide Emergency Services at Aerodromes for which they are responsible.

**Acceptable
Means of
Compliance
3261(2)**

Aerodrome Emergency Services

50. ▶ **Aerodrome Emergency Services¹ should not be reserved solely for flying operations. ARFF and Emergency Medical Services²⁰** ◀ **should** respond to all Incidents ▶ ◀ across the MOD estate where local conditions allow, as a priority, when life may be at Risk. Any consequent effect on Aerodrome operations through a reduction or total loss of Crash Category **should** be considered secondary to the saving of life.

51. **Communications.** ATC **should** be connected by adequate ground communications to Safety Services and Station ▶ / **Unit** ◀ departments concerned with flying. These communications ▶ **should as a minimum be:** ◀

- a. **Direct Line Communication.** Direct line communication to:
 - (1) Station Fire Section (if separate from the crash bay).
 - (2) Station Medical Centre (where applicable).
 - (3) Crash Crew Bay.
 - (4) ▶ ◀ ATC Centre (ATCC).
 - (5) Distress and Diversion Cell (D&D). ▶ ◀
- b. **Indirect Telephone Communication.** Indirect telephone communication to:
 - (1) ▶ **Duty Aircrew.** ◀
 - (2) All flying squadrons and flights.
 - (3) Senior Engineering Officer (SEngO).
 - (4) Station Works Services²¹ representatives.
 - (5) Local civil Emergency Services.
 - (6) Local police.
- c. **RTF Communication.** RTF communication between the ATC Tower and the ▶ **Aerodrome Emergency Service¹** ◀ vehicles, and vehicles employed in Aircraft ▶ **brake** ◀ parachute recovery role.
- d. **Crash Alarm Bells / Telephones.** Crash alarm bells / telephones (operated from the Controller's position) to:
 - (1) Crash Crew Bay.
 - (2) Station Fire Section (if separate from Crash Crew Bay).
 - (3) Station Medical Centre (where applicable).
- e. **Station / Unit Broadcast System.**

52. **Crash Maps.** The Aerodrome Operator (AO) **should** arrange for the production, distribution ▶ **and document control** ◀ of local area and Aerodrome crash maps to enable the rapid location of Aircraft crashes and Aerodrome Incidents as follows:

¹⁹ Relevant NATO STANAGs can be accessed via the Defence Standards intranet site.

²⁰ ▶ **Refer to AP1269 Leaflet 12-8: Guidance on the Standards of Medical Cover for Military Aerodromes.** ◀

²¹ Representing Defence Infrastructure Organisation (DIO).

**Acceptable
Means of
Compliance
3261(2)**

- a. **Local Area Crash Map.** A local area crash map **should** consist of an Ordnance Survey map to a range of at least a 5 nm radius from the Aerodrome. The map **should** show, as a minimum:
- (1) Areas of overlapping cover with adjacent Aerodromes.
 - (2) Areas of known poor RTF communications.
 - (3) Any other locally required features, eg rendezvous points.
- b. **Aerodrome Crash Map.** An Aerodrome crash map **should** be produced covering the Aerodrome and its surrounds within reasonable visual range of the ADC. The map, which may be orientated to meet local requirements, eg as the ADC sees the Aerodrome from their control position, will be overlaid with a simple ►◄ grid system. The grid **should** be of reasonable size (not too small), ideally aligned along the main instrument Runway, and arranged that significant areas are not divided by grid lines. In addition the following features **should** be clearly depicted:
- (1) North orientation.
 - (2) Runway magnetic headings.
 - (3) Taxiways and dispersals.
 - (4) All roads and tracks fit to take ► Aerodrome Emergency Service¹ ◄ vehicles.
 - (5) Main road junctions and crossings.
 - (6) Hazards such as ditches and narrow or difficult areas.
 - (7) Areas which are not negotiable by ► Aerodrome Emergency Service¹ ◄ vehicles:
 - (a) At all times.
 - (b) At certain times of the year owing to weather and / or tides.
 - (8) All points of exit from the Aerodrome, eg hedge gaps, bridges over ditches, gateways, etc.
 - (9) Areas of known poor RTF cover.
 - (10) Crash exits, which will be numbered.
- c. **Crash Map Distribution.** Local area and Aerodrome crash maps **should**, be located in:
- (1) Station / Unit Headquarters;
 - (2) ATC;
 - (3) TRC iaw ► RA 3279(4)²²; ◄
 - (4) ► Station ◄ Fire Section ► / Crash Crew Bay; ◄
 - (5) Station Medical Centre;
 - (6) ►◄
 - (7) ►◄
 - (8) ►◄
 - (9) ►◄
 - (10) ►◄
 - (11) ► All essential Aerodrome and ◄ ATC vehicles;
 - (12) Other locations as defined in ►◄ Local orders; ► with consideration to the following where appropriate:
 - (a) Local civil Emergency Services.

²² ► Refer to RA 3279(4): Equipment and Operating Requirements – Truck Runway Control. ◄

**Acceptable
Means of
Compliance
3261(2)**

- (b) Station crash / salvage section.
- (c) Search and Rescue (SAR) helicopter.
- (d) Executive vehicles. ◀
53. ▶ ◀
54. **Crash Exits.** ▶ Crash exits **should** be:
- Numbered iaw the Aerodrome crash map.
 - Kept clear and have appropriate signage displayed to this effect.
 - Signposted where the location of the crash gate is not obvious.
55. On Aerodromes where crash gates are locked for security reasons, crash crews **should** be in possession of crash gate keys that are tagged for quick identification. Duplicate keys **should** be readily available in a known location. ◀
56. **Testing of the Crash Organization.** The AO is responsible for ensuring that the ▶ **Aerodrome Emergency Services**¹ ◀ are adequately prepared to cover the flying task. The ARFF services **should** be exercised with any lessons identified being recorded and actioned. Full advantage **should** be taken of any planned participation by the civilian emergency services.
57. **Testing of Crash / Rescue Communications.** The ATC Officer in command (ATCO IC) (or other responsible individual ▶ **specified** ◀ in ▶ ◀ Local Orders) **should** ascertain the serviceability state of the ARFF ▶ **and emergency medical** ◀ services, RTF equipment, crash telephone, teletalk, and crash alarm systems at the start of their watch. They **should** take immediate action, in the event of any unserviceability, to have repairs effected, and to make temporary alterations to the disposition of vehicles if this is necessary. Any unserviceability **should** be recorded and reported iaw RA 3204²³ and RA 3206²⁴.
58. ▶ ◀
59. ▶ ◀
60. ▶ ◀
61. ▶ ◀
62. ▶ ◀
63. ▶ ◀
64. ▶ ◀
65. ▶ ◀
66. ▶ ◀

**Guidance
Material
3261(2)**

Aerodrome Emergency Services

67. ▶ The use of what3words by civil emergency services is common practice and Units may want to consider annotating key reference points on the Aerodrome to assist such users that are likely to be unfamiliar. ◀

**Regulation
3261(3)**

Aerodrome Service in Class D Airspace

- 3261(3) ▶ **Head of AA-Facing** ◀ Organizations and HoE at Aerodromes inside Class D airspace **shall** ▶ **ensure an ATS is provided iaw the airspace classification.** ◀

²³ Refer to RA 3204 – Air Traffic Management Records.

²⁴ Refer to RA 3206 – Air Traffic Management Equipment Checks.

**Acceptable
Means of
Compliance
3261(3)**

Aerodrome Service in Class D Airspace

68. **Class D Flight Rules.** Whilst there is a requirement for Controllers to monitor the Met conditions, Controllers **should** also establish the flight rules that Aircraft are operating iaw, to ensure the appropriate ATS provision in Class D airspace. The pilot is responsible for determining the flight rules under which they wish to conduct their flight iaw RA 2307²⁵, taking into account the Met conditions, airspace classification and the limitations of their licence / qualifications. Ground visibility **should** be used for Aircraft taking-off from or approaching to land, whereas flight visibility **should** be used for transiting Aircraft (which may require entering an ATZ or Aerodrome traffic circuit); therefore, Controllers **should not** declare Class D Airspace to be 'IFR' or 'IMC'.

69. **Class D ATS Provision.** All flights **should** be provided with an ATS as follows:

- a. All flights **should** be subject to ATC clearance.
- b. IFR flights **should** be separated from other IFR and Special VFR flights.
- c. IFR flights **should** receive TI in respect of VFR flights.
- d. IFR flights **should** receive traffic avoidance advice on request.
- e. VFR flights **should** receive TI in respect of all other flights and traffic avoidance advice on request.

70. **Cancelling IFR.** IFR flights **should** be afforded IFR separation until IFR flight is cancelled. A change **should** be accompanied by a statement from the Aircraft operator that cancels IFR flight iaw RA 2307²⁵, paragraph ▶49.◀ This information is paramount in determining the actions in the event of an Aircraft being instructed to Go Around whilst conducting an IFR approach.

71. **Class D VFR Operations.** Controllers **should** permit Aircraft operating under VFR to operate to or from an Aerodrome in Class D airspace (which may require entering an ATZ or active Aerodrome traffic circuit) iaw with the limitations dictated by the pilot's flight rules and the reported Met conditions as follows:

- a. **Flight Rules.** When the reported Met conditions reduce below the minima at paragraph ▶71b,◀ Controllers **should** request the pilot to specify the type of clearance required, (in order to ascertain the pilot's flight rules iaw RA 2307(1) Table 1 UK VMC Minima for VFR Flight).
- b. **Met Conditions:** Controllers **should not** issue any further VFR clearances to Aircraft wishing to operate iaw VFR when the reported Met conditions fall below the following minima:
 - (1) The cloud ceiling is less than 450 m (1500 ft).
 - (2) Aircraft other than helicopters: ground visibility 5 km.
 - (3) Helicopters: ground visibility 1500 m.

72. **Class D Special VFR Operations.** Controllers **should** issue a Special VFR clearance to Aircraft wishing to operate under Special VFR, during the day or night as follows:

- a. **Special VFR Transits.** Controllers **should** permit Aircraft operating Special VFR to transit to or from an Aerodrome in Class D airspace (which may require entering an ATZ or active Aerodrome traffic circuit) iaw the following criteria:
 - (1) Aircraft is below 140 knots indicated air speed (IAS).
 - (2) Aircraft is clear of cloud with the surface in sight.
 - (3) Aircraft other than helicopters: minimum flight visibility 1500 m.
 - (4) Helicopters: minimum flight visibility 800 m.
- b. **Special VFR Landing and Taking Off.** Except for helicopters using a Rescue call sign²⁶, Controllers **should not** give permission for Aircraft to land or

²⁵ Refer to RA 2307 – Rules of the Air.

²⁶ Police, Helicopter Emergency Medical Services / Helimed, Rescue, including SAR training flights operating iaw a Letter of Agreement with the ATS Provider.

**Acceptable
Means of
Compliance
3261(3)**

take off from an Aerodrome within Class D airspace when the reported met conditions fall below the following minima:

- (1) Aircraft other than helicopters: ground visibility 1500 m and / or cloud ceiling 600 ft.
- (2) Helicopters: ground visibility 800 m and / or cloud ceiling 600 ft.

c. **Special VFR Ground Visibility.** When the reported ground visibility consists of two values, the lower of the two values **should** be used when determining if a Special VFR clearance can be issued.

73. **Shared Class D Airspace.** Procedures for operations at MOD Aerodromes located within Class D airspace where the controlling agency is not the control authority **should** be contained within Letters of Agreement and detailed in Local Orders. ▶ ◀

**Guidance
Material
3261(3)****Aerodrome Service in Class D Airspace**

74. Nil.

Intentionally Blank for Print Pagination

RA 3262 – Aerodrome Access

Rationale

The effective operation of an Aerodrome requires the safe and expeditious integration of ► Aircraft, ◀ vehicles and pedestrians on the runway and Aerodrome movement area¹. Uncontrolled access may introduce operating Hazards that could impact on Air Safety and result in Aviation Risk to Life (RtL). The management of Aerodrome access will ensure that operating Hazards are identified and managed, and that RtL remains As Low as Reasonably Practicable and Tolerable.

Contents

RA 3262(1): Aerodrome Access

Regulation 3262(1)

Aerodrome Access

3262(1) Aviation Duty Holders (ADH), ADH-Facing organizations and Heads of Establishment (HoE) **shall** employ processes that limit access to the runway and Aerodrome movement area to authorized personnel.

Acceptable Means of Compliance 3262(1)

Aerodrome Access

1. ADHs, ADH-Facing organizations and HoE **should** employ an Aerodrome access system appropriate to the Aerodrome operation. Units **should** produce and manage Aerodrome access orders which detail the process by which personnel can obtain a permit enabling access to the Aerodrome movement area. The process **should** detail, but not be limited to:
 - a. Responsibility for issue of Aerodrome access permits.
 - b. How Aerodrome access permits are to be presented and issued.
 - c. Training, briefing and testing requirements.
 - d. Periodicity of Aerodrome access permit.
 - e. Audit and assurance process (eg spot checks).
 - f. When permits can be revoked or suspended.
 - g. Details of access procedures during closed hours.
 - h. Types of access allowed, eg vehicle, cycle, pedestrian.
 - i. Minimum and maximum speed limits.
 - j. Details of runway and Aerodrome movement area boundaries and process for managing incursions.
 - k. Parking arrangements.
 - l. Requirement for mandatory Foreign Object Damage / Debris checks.
2. Personnel requiring access to the Aerodrome **should** comply with Local / Unit Orders governing access to, and driving of vehicles on, the Aerodrome, and pass an exam on the content of these orders. The exam **should** contain questions specific to the level of access being granted by the permit system, evenly balanced between general and Aerodrome specific orders, and the pass mark **should** be 100%.
3. Signals that **should** be used in the control of vehicles and pedestrians are as per Table 1 (STANAG 3758²):

¹ The Aerodrome movement area is that part of an Aerodrome to be used for the take-off, landing and taxiing of the ► Aircraft, ◀ consisting of the manoeuvring area and the apron(s).

² ► Refer to ◀ STANAG 3758 - Signals Used by Air Traffic Service Units for the Control of Pedestrians and Vehicular Traffic in the Manoeuvring Area of Airfields.

**Acceptable
Means of
Compliance
3262(1)**

Table 1. Signals for control of vehicles and pedestrians.

| Type of Signal | Meaning of Signal | Remarks |
|----------------------|---|---|
| Green Flashing Light | Cleared to Proceed | |
| Steady Red Light | Stop | In cases of emergency a red pyrotechnic may be fired horizontally |
| Red Flashing Light | Clear the Runway or taxiway immediately | |
| White Flashing Light | Return to starting point or do as briefed | |

4. All personnel requiring an Aerodrome access permit **should** be colour perception (CP) standard of CP2 (normal) or CP3 (defective safe).
5. Details of the Unit Aerodrome access permit system **should** be detailed in the Defence Aerodrome Manual in accordance with (iaw) RA 1026³.

**Guidance
Material
3262(1)**

Aerodrome Access

6. **Clearance Limits.** Air Traffic Control (ATC) may restrict the progress of a vehicle as necessary, utilizing 'Clearance Limits' to minimize the chances of a vehicle operating outwith the bounds of their clearance. Unrestricted access on any part of the Aerodrome movement area may be prohibited at certain times.
7. **Local / Unit Orders.** Local / Unit Orders will, as a minimum, include:
- The layout of the Aerodrome Movement Area, including Runways, Taxiways, dispersals and vehicle routes and access.
 - The layout of the Aerodrome Lighting.
 - The Runway configuration and where appropriate, the Runway in use, as well as direction of taxiing ► **Aircraft** ◀ and Dispersals / Aprons being used.
 - Where ► **Aircraft** ◀ are normally to be encountered.
 - Right of way rules and distance to be maintained from ► **Aircraft** ◀ iaw RA 2307⁴.
 - The method of ground control.
 - The method of marshalling in force and when a marshal is to be used.
 - Visual signals employed on the Aerodrome.
 - Radiotelephony procedures and phraseology.
 - Use of vehicle headlights. When the vehicle is in motion, the headlights ► **will** ◀ be on and dipped.
 - Action to be taken in an emergency or in the event of a breakdown:
 - Vehicles will be equipped with serviceable hazard warning lights or drivers will carry a serviceable red torch for use in the event of breakdown.
 - Drivers may warn pilots of taxiing ► **Aircraft** ◀ by shining a steady red torch beam at the cockpit if it is evident that the broken-down vehicle constitutes an immediate Hazard to the ► **Aircraft**. ◀
 - The occasions when it is necessary for a driver of a vehicle to report directly to ATC before proceeding on to the Movement Area.
 - Speed limits in force (Recommended maximum 30 mph (50 kph) by day and 20 mph by night) and the occasions or activities when excessive speed limits may be employed.
 - In general, vehicles will not overtake other moving vehicles.
8. **CP at non-ATC equipped Units.** At Aerodromes where there is no established ATC presence, and where there are no vehicular traffic lights, pyrotechnics, lamp

³ ► Refer to ◀ RA 1026 – Aerodrome Operator and Aerodrome Supervisor (Recreational Flying) Roles and Responsibilities ► ◀.

⁴ ► Refer to ◀ RA 2307 – Rules of the Air.

**Guidance
Material
3262(1)**

signals or other red / green system employed to signal / control vehicles on the Aerodrome movement area, a minimum CP standard is not required for the issue of an ► **Aerodrome Access** ◀ Permit.

9. **Tiered Permits.** A tiered system may be utilized which will allow training to be tailored to meet differing user requirements. Individuals may be assessed by their own line-management on their requirement for additional training if their role necessitates further access. Examples of tiers and limited permits could include (but are not limited to) Runway, Manoeuvring Area, Apron only access, MT route, Taxiways and Aprons permit etc. Units may group and title zones as required for their operation, for example:

a. **Tier 1.** Personnel commuting to a place of work who will transit the Manoeuvring Area.

b. **Tier 2.** Personnel whose primary duty is associated with operations on the Manoeuvring Area (eg ► **Aircraft** ◀ engineers).

10. **Runway and Aerodrome Movement Area Incursion.** All runway⁵ and Aerodrome movement area incursions will be reported iaw RA 1410⁶, with the relevant boxes selected and specific mention of runway or Aerodrome movement area incursion in the title to aid analysis.

11. Although the MOD have not adopted the Civil Aviation Authority requirements for Aerodrome Permits, additional information on Aerodrome Permits may be found in CAP 790⁷.

⁵ In the context of a runway incursion, the runway is deemed to include both the physical surface of the runway and the Runway End Safety Area and Clearway.

⁶ ► **Refer to** ◀ RA 1410 – Occurrence Reporting and Management.

⁷ ► **Refer to** ◀ CAP 790 – Requirement for an Airside Driving Permit Scheme.

Intentionally Blank for Print Pagination

RA 3263 - Aerodrome Classification

Rationale *There is a requirement to classify MOD Aerodromes.*

Contents **3263(1): Aerodrome Classification**

Regulation **Aerodrome Classification**

3263(1) MOD Aerodromes **shall** be classified in order to define operational and safeguarding requirements.

Acceptable Means of Compliance
3263(1)

Aerodrome Classification

1. MOD Aerodromes **should** be classified¹ by Front Line Commands (FLCs) as follows:

Military Emergency Diversion Aerodrome (MEDA)

a. MEDAs **should** be operated on a continuous basis. They **should** be equipped with ground facilities, engineering systems and safety services and provide facilities for the handling of all types of UK Military Air System, as follows:

(1) A minimum Runway length of 7000 ft and Manoeuvring Area capable of supporting the landing techniques and operating requirements of any type of Air System.

(2) Navigation, approach services, appropriate radio (including Very High Frequency (VHF) / Ultra High Frequency (UHF) emergency frequencies) and radar approach aids.

(3) Fire and Crash Rescue **should** be maintained at a minimum level as detailed in DSA02 DFSR².

(4) Medical Cover. FLCs **should** ensure that emergency medical cover is available to provide an immediate response; the level of response **should** be proportionate to the Aerodrome's location, flying activity being conducted and the Air Systems involved. For a MEDA the minimum cover **should** be an aerodrome ambulance, driver and appropriately trained medical orderly at immediate readiness on Unit. An aviation medicine trained medical officer / civilian medical practitioner **should** be immediately contactable by phone or pager to provide urgent aviation medicine and specialist advice in support of the emergency medical services; they **should** be able to attend the airfield within 2 hours.

b. FLCs **should** define the process for transfer of MEDA commitment, in the event that the nominated MEDA Aerodrome is no longer able to satisfy the requirements.

c. Navigation and Approach Services and Engineering facilities provided by MEDAs may be reduced from 0200 (local) to 0730 (local) on Tuesday, Wednesday, Thursday and Friday and from 1730 (local) on Friday until 0730 (local) Monday. These reductions **should** provide no less than:

(1) Navigation and Approach Services. A minimum handling capacity of 6 Air Systems per hour, ie one Air System every 10 minutes.

¹ Refer to RA 1010 - Head of Establishment (HoE) – Aviation Responsibilities - where site, establishment or bases are referred to as Tier 1, Tier 2 or Tier 3 classification; this enables the HoE to meet MRP compliance in line with RA 1026 – Aerodrome Operator and Aerodrome Supervisor (Recreational Flying) Roles and Responsibilities including Aerodrome and Helicopter Landing Site Assurance Requirements. The use of 'Tier' does not affect the aerodrome classification in this RA.

² Refer to DSA02 DFSR: Defence Aerodrome Rescue and Fire Fighting Regulations.

**Acceptable
Means of
Compliance
3263(1)**

(2) Engineering Support. Air System marshalling and parking only. There will be no facilities for turn round or rectification of diverted Air Systems.

Extended Hours Aerodromes

d. Extended Hours Aerodromes, in addition to operating to FLC requirements, **should** have extended operating hours to meet pre-booked diversion commitments when unit requirements have ceased. Operating hours **should** be as follows:

- (1) From 0800 (local) to 2359 (local) Monday to Thursday.
- (2) From 0800 (local) to 1800 (local) Friday.

e. They **should** have ground facilities, engineering systems and safety services as follows:

- (1) A Runway, Manoeuvring Area and technical services able to serve the requirements of Air Systems utilizing the Aerodrome as a pre-booked diversion.
- (2) VHF / UHF communications and radio and / or radar approach aids to meet their operational role.
- (3) Navigation and Approach Services. A minimum handling capacity to meet the pre-booked diversion commitment.
- (4) Fire and Crash Rescue maintained at the published station level in accordance with (iaw) DSA02 DFSR.
- (5) Medical Cover. FLCs **should** ensure that emergency medical cover is available to provide an immediate response; the level of response **should** be proportionate to the Aerodrome's location, flying activity being conducted and the Air Systems involved. An aviation medicine trained medical officer / civilian medical practitioner **should** be immediately contactable by phone or pager to provide urgent aviation medicine and specialist advice in support of the emergency medical services: they **should** be able to attend the airfield within 2 hours.
- (6) Engineering Support. Air System marshalling and parking only. There will be no additional facilities ie forward-firing weapon slots, Hardened Air System Shelter parking, hangarage, turn round or rectification of diverted Air System unless previously agreed.

Temporary Reduction in Extended Hours Capability

f. In exceptional circumstances, Extended Hours Aerodromes can apply for a temporary cessation of Extended Hours status. FLCs **should** define the process for reduction in extended hours capability.

Standard Aerodromes

g. Standard Aerodromes **should** be operated to a FLC requirement. They **should** be equipped with VHF / UHF communications and radio and / or radar approach aids to meet their operational role. FLCs **should** provide orders for Standard Aerodromes under their command; these orders **should** cover:

- (1) Operating Hours.
- (2) Runway and Manoeuvring Area details.
- (3) Fire and Crash Rescue maintained at the published station level iaw DSA02 DFSR.
- (4) Medical Cover. FLCs **should** ensure that emergency medical cover is available to provide an immediate response; the level of response **should** be proportionate to the Aerodrome's location, flying activity being conducted and the Air Systems involved. An aviation medicine trained medical officer / civilian medical practitioner **should** be immediately contactable by phone or pager to provide urgent aviation

**Acceptable
Means of
Compliance
3263(1)**

medicine and specialist advice in support of the emergency medical services: they **should** be able to attend the airfield within 2 hours.

- (5) Engineering Support.

Miscellaneous Aerodromes

h. Miscellaneous Aerodromes **should** be those at which the flying role requires a lesser scale of VHF / UHF communications and approach aids than is specified for Standard Aerodromes, eg Relief Landing Grounds. FLCs **should** provide orders for Miscellaneous Aerodromes under their command where they differ from Standard Aerodromes. These orders **should** be safety managed iaw RA 1200³, and **should**, as a minimum, cover:

- (1) Operating Hours.
- (2) Runway and Manoeuvring Area details.
- (3) Navigation and Approach Services available.
- (4) Fire and Crash Rescue facilities.
- (5) Medical Cover. FLCs **should** ensure that emergency medical cover is available to provide an immediate response; the level of response **should** be proportionate to the Aerodrome's location, flying activity being conducted and the Air Systems involved.
- (6) Engineering Support.

Tactical / Temporary Aerodromes

i. Tactical / Temporary Aerodromes **should** be those defined as a natural, semi-prepared or prefabricated strip with surface, slope, dimensions, load bearing capacity and clearance from obstruction sufficient to allow Air Systems to operate safely in specified weather conditions. Full criteria and operating requirements for each category of tactical / temporary Aerodrome are detailed in RA 3550⁴.

Rotary Wing Permanent Bases

j. The categorization of rotary wing permanent base Movement Areas **should** be by 'Performance Class' of the design helicopter as detailed in RA 3530(3)⁵.

Domestic Helicopter Landing Sites

k. Full criteria and requirements for each category are detailed in RA 3531(9)⁶.

2. All classifications of military Aerodrome **should** remain open during notified operating hours except in the following circumstances:

- a. For periods or under conditions agreed by the appropriate Command and published in a Notice to ►Aviation.◄
- b. When the Aerodrome is unfit for the safe operation of Air Systems.

3. When it is decided that the Aerodrome is to be closed, Units **should** take the following actions, where relevant:

- a. Notify all Air Systems under the control of the unit.
- b. Notify the following authorities:
 - (1) Distress and Diversion (D&D) Cell.
 - (2) The Air System operating authorities concerned.
 - (3) The Air Traffic Control Centre (ATCC) controller, if appropriate.

³ Refer to RA 1200 – Air Safety Management.

⁴ Refer to RA 3550 – Temporary Landing Zone.

⁵ Refer to RA 3530(3): Permanent Helicopter Landing Sites – Helicopter Performance Class.

⁶ Refer to RA 3531(9): Domestic Helicopter Landing Site.

**Acceptable
Means of
Compliance
3263(1)**

- c. Notify all sections associated with flying.
- d. Ensure any diversion commitments are cancelled.

**Guidance
Material
3263(1)****Aerodrome Classification**

4. **Medical Cover.** AP1269 Lflt 12-08⁷ is to be used to determine proportionate medical cover. It provides a framework for the requirement to undertake a medical risk assessment to determine the level of medical cover required at each location.

⁷ Refer to AP 1269 – The RAF Manual of Medical Administration, Lflt 12-08 – Guidance on the Standards of Medical Cover for Military Aerodromes.

► This RA has been substantially re-written; for clarity no change marks are presented – please read RA in its entirety ◀

RA 3264 - Aerodrome Inspections

Rationale

An Aerodrome is intended to be a safe place for Aircraft to operate from. Without appropriate inspection regimes being conducted to identify any potential Hazards, Risk may not be identified and appropriate action could be missed. This could lead to an increased likelihood of Aircraft Incidents or Accidents. It is therefore necessary to conduct inspections of the Aerodrome, Movement Area and equipment at regular intervals and take action, if required, to ensure that a Safe Operating Environment remains.

Contents

3264(1): Aerodrome Inspections

Regulation 3264(1)

Aerodrome Inspections

3264(1) Inspections of the Aerodrome, Movement Area and equipment **shall** be undertaken at MOD Aerodromes.

Acceptable Means of Compliance 3264(1)

Aerodrome Inspections

1. **Daily Aerodrome inspections.** As a minimum **should** be undertaken:
 - a. **At 24 hr units** - As soon as practicable after first light and again before last light and **should** include a functional test of Aerodrome lighting.
 - b. **At non-24 hr units:**
 - (1) Before the Aerodrome is opened and **should** include a functional test of Aerodrome lighting. If the initial inspection is carried out in darkness, a further inspection **should** be carried out at first light.
 - (2) Before last light if the Aerodrome has been open for day flying and night flying is planned, it **should** include another functional test of Aerodrome lighting.
2. **Weekly Aerodrome inspection¹.** This is in addition to the daily inspection and **should** ensure that any previously reported defects or reports of unserviceability's have been appropriately repaired / actioned.
3. **Ad Hoc Aerodrome inspection.** Additional Aerodrome inspections **should** be carried out in accordance with (iaw) local / unit orders or when the Air Traffic Control Officer in Charge considers it necessary.
4. An Aerodrome inspection **should** be undertaken post Accident / Incident on the Aerodrome.
5. **Qualifications.** Aerodrome inspections **should** be conducted by a Suitably Qualified and Experienced Person (SQEP):
 - a. Front Line Commands **should** issue orders that specify the SQEP criteria required to conduct both daily and weekly Aerodrome inspections.
6. As a minimum, Aerodrome inspections **should** include:
 - a. A physical check of the Movement Area, identifying and reporting any degradation of the surfaces.
 - b. A visual check of the shoulders, Runway / taxiway strips and the Runway End Safety Areas for any unknown obstacles².
 - c. Retrieving and reporting any Foreign Object Debris found.

¹ Aerodromes that open less than 3 days a week, if deemed appropriate, can combine the daily and weekly inspection but **should** ensure it meets the requirements of both.

² Refer to RA 3590(10): Safeguarding – Surface Obstructions.

**Acceptable
Means of
Compliance
3264(1)**

- d. A check of all Aerodrome lighting³ to ensure it is functional and not obscured.
7. Aerodrome inspections **should** include a check of the serviceability and function of Aerodrome Arrestor Gear and Barriers. Local / Unit Orders **should** define who is responsible for completion of these checks.
8. Personnel who undertake daily inspections of Aerodrome surfaces at Aerodromes where Rotary Hydraulic Arrestor Gear (RHAG) are fitted **should** be cognisant of the Hazard that imperfections on a Runway surface can present to RHAG operations. Any imperfections of the Runway surface that could cause an arrester hook to skip into the air and result in a missed cable engagement **should** be identified and arrangements made for rectification to be completed as soon as practicable. Aircraft equipped with a hook **should** be made aware of any such imperfections.
9. Aerodrome inspections **should** identify any dangerous or unusual conditions which **should** be recorded within the Aerodrome Operators Hazard Log iaw RA 1026(2)⁴, and reported to the appropriate authority as defined in unit orders. The following information **should** be recorded:
- a. Nature and position of the unserviceable area or obstruction.
 - b. Nature of markings by day and night.
 - c. Approximate period for which the area will remain unserviceable.
10. A report of the daily / weekly inspection **should** be entered into an appropriate log.

**Guidance
Material
3264(1)****Aerodrome Inspections**

11. The requirements for Aerodrome Maintenance and safeguarding are captured in RA 3590⁵.

³ Excludes off site Aerodrome lighting which **should** be checked by the Airfield electrician iaw local orders.

⁴ Refer to RA 1026(2): Aerodrome Operator Responsibilities.

⁵ Refer to RA 3590 – Maintenance and Safeguarding.

RA 3265 - Aerodrome Lighting Operating Requirements

Rationale

Standard Aerodrome lighting and associated operating procedures ► facilitate the provision of Aerodrome operations at night or during inclement weather. Without appropriate lighting and operating procedures there is an increased Risk to Life due to the potential for Aircraft accidents. Therefore, Aerodrome lighting and associated operating procedures ◀ need to be maintained on Aerodromes and approaches to Runways.

Contents

3265(1): Aerodrome Lighting Operating Requirements
3265(2): Night Vision Devices Operating Requirements

Regulation 3265(1)

Aerodrome Lighting Operating Requirements

3265(1) Units **shall** operate Aerodrome lighting and Identification Beacons as specified.

Acceptable Means of Compliance 3265(1)

Aerodrome Lighting Operating Requirements

1. Aerodrome lighting **should** be switched on 15 minutes before any Estimated Time of Arrival (ETA) and remain on for 15 minutes after any Actual Time of Departure (ATD) of an ► Aircraft ◀ in the following conditions:
 - a. **By Day.** Whenever the visibility is less than 8 km and / or the cloud base is less than 700 ft.
 - b. **By Night.** Irrespective of weather conditions, unless operational or exercise requirements dictate otherwise. Night is defined as 30 minutes after sunset to 30 minutes before sunrise.
2. Sodium lamps require 10 to 15 minutes to reach full brilliancy and **should** therefore be switched on 30 minutes before any ETA or required usage.
3. Lighting settings **should not** be altered when an ► Aircraft ◀ is on final approach unless the pilot requests the alteration.
4. The Aerodrome Lighting Brilliancy Guide **should** be displayed on, or immediately adjacent to, the Aerodrome lighting console.

Guidance Material 3265(1)

Aerodrome Lighting Operating Requirements

5. **Recommended Aerodrome Lighting Brilliancy Settings.** To provide some guidance and uniformity, Table 1 contains the minimum recommended brilliancy settings for Approach / Runway Lights and Precision Approach Path Indicators (PAPIs), to be used for varying surface visibilities in daylight, twilight and at night. The table, based on the visibilities which determine Aerodrome weather states, is only a guide and actual local conditions or operations may require minor alterations to the recommended settings.

Table 1. Aerodrome Lighting Brilliancy Setting Guide.

| | VISIBILITY | APPROACH / RUNWAY | PAPIs |
|----------|---------------|-------------------|-----------|
| DAYLIGHT | 0 – 3700 M | MAX | MAX/ 2 |
| | 3700 M – 8 KM | MAX | 2 |
| | 8 KM + | OFF | 2 |
| TWILIGHT | 0 – 1600 M | 2 | 4 |

**Guidance
Material
3265(1)**

| | | | |
|-------|-----------------|---|-----|
| | 1600 M – 3700 M | 3 | 5 |
| | 3700 M – 5 KM | 4 | 5 |
| | 5 KM + | 5 | MIN |
| NIGHT | 0 – 1600 M | 3 | 4 |
| | 1600 M – 5 KM | 4 | 5 |
| | 5 KM + | 5 | MIN |

Notes:

1. Settings may be raised by one stage when any of the following conditions exist:
 - a. Cloud base below 1000 ft.
 - b. Moderate to heavy rain.
 - c. $\frac{3}{4}$ moon or more at night.
2. Settings may be adjusted at the request of the pilot.
6. Lighting can also be set as requested by the pilot, required by unit instructions or as considered necessary by the Aerodrome Controller.
7. PAPIs may be left on during Aerodrome operating hours if required.

**Regulation
3265(2)**

Night Vision Devices Operating Requirements

3265(2) Units **shall** plan for Night Vision Device (NVD) Operations.

**Acceptable
Means of
Compliance
3265(2)**

Night Vision Devices Operating Requirements

8. Units **should** design and publish an Aerodrome NVD Operations Lighting Control Plan which **should** be included in the Defence Aerodrome Manual in accordance with RA 1026¹. The NVD Operations Lighting Plan **should** include lighting control measures necessary to ensure that the performance of NVD is not significantly degraded by any light on or adjacent to the Aerodrome. The effectiveness of the NVD Operational Lighting Control Plan **should** be checked by means of a flight check.

9. The NVD Operations Lighting Control Plan **should** define which Runway approach directions are designed to support NVD operations. The plan **should** also indicate which of the types of operations are supported. Different requirements will apply for the various operational types listed below:

- a. Fixed wing (FW) operations with NVD (FW NVD)
- b. Rotary Wing (RW) operations with NVD (RW NVD)
- c. Simultaneous FW and RW operations with NVD (FW / RW NVD)
- d. Simultaneous operation with and without NVD (Sim NVD)

10. Procedures for final approach, taxi and departure **should** be reviewed and amended as necessary to take account of the changes to the visual cues available to pilots when NVD operations are taking place.

11. Where NVD operations are to take place, all personnel involved **should** receive training that includes the light control measures and operational procedures to be used when NVD operations are taking place.

12. Only personnel whose presence is essential for safety and efficiency reasons **should** be on the Manoeuvring Area during NVD operations.

¹ Refer to RA 1026 – Aerodrome Operator and Aerodrome Supervisor (Recreational Flying) Roles and Responsibilities ►◄.

**Guidance
Material
3265(2)**

Night Vision Devices Operating Requirements

13. NVD are designed to operate with low levels of light. Sources that emit high levels of infra-red radiation can reduce the contrast of the image seen by Aircrew. In more extreme cases the infra-red glare can completely disable the NVD. The use of NVD generally reduces the amount of visual aids that are necessary to support night operations. NVD operations may require the retention of some visual aids, suitably modified to be compatible with the use of NVD or the provision of aids specifically for that mode of operation. The selection of lights to be controlled during NVD operations is an operational decision. For FW operations the most basic plan may only retain obstacle lighting. For RW operations the Plan may include the NATO T and an identification beacon.

14. Suggested lighting states are shown in Table 2. The choice of lighting to be controlled is the responsibility of the Aviation Duty Holder.

Table 2. Suggested Lighting States.

| FACILITY | RECOMMENDED NVD LIGHTING STATE |
|-------------------------------------|--------------------------------|
| Approach lighting | VLP / Off |
| High Intensity Runway Edge Lighting | VLP |
| Threshold Lighting | VLP |
| Runway End Lighting | VLP |
| Low Intensity Runway Edge Lighting | VLP |
| Sequence Flashing Lights | Off |
| Runway Identification Lights | Off |
| Visual Glideslope Indicator System | Off |
| Military Cat II Lighting | Off |
| Runway Centre-line Lighting | Off |
| Taxiway Lighting | VLP |
| Illuminated Runway Distance Markers | Off |
| Arrestor Cable Markers | Off |
| Illuminated Taxiway Guidance Signs | Off |
| Obstacle Lighting | On |
| Runway taxiway traffic lights | Off |
| Floodlighting | Off |
| Infra-Red NATO T | On |
| Infra-Red identification beacon | On |

VLP – Very Low Power setting, typically 5-10% of rated power.

15. Details on NVD lighting can be found in the ► [RA 3500 Series of Regulations: Aerodrome Design and Safeguarding.](#) ◀

Intentionally Blank for Print Pagination

RA 3266 – Aerodrome Maintenance

Rationale

Maintenance is often required to be carried out on the Aerodrome and its associated facilities. In order to ensure that a safe operating environment can be maintained, Aerodromes need to plan for Maintenance and Work In Progress (WIP).

Contents

3266(1): Aerodrome Maintenance

3266(2): Work In Progress Map

Regulation

3266(1)

Aerodrome Maintenance

3266(1) To ensure a safe operating environment, units **shall** plan for Maintenance and WIP.

Acceptable Means of Compliance 3266(1)

Aerodrome Maintenance

1. Projects and Maintenance affecting Aerodromes **should** be planned and managed to ensure a safe operating environment is maintained. Where such work affects the availability of Aerodrome surfaces or services, this **should** be notified in accordance with (iaw) RA 1026(4)¹.
2. **WIP Briefings.** The Senior Air Traffic Control Officer (SATCO) **should** ensure that working parties are appropriately briefed prior to commencing work on the Aerodrome. As a minimum, the briefing **should** include the following details:
 - a. Limits of the work area.
 - b. Direction of ►Aircraft◄ movements.
 - c. Route to be taken by works vehicles.
 - d. Parking area for works vehicles and equipment.
 - e. Control to be exercised over works vehicles and ►workforce◄.
 - f. Lamp and pyrotechnic signals that may be employed.
 - g. Foreign Object Damage prevention.
 - h. Any additional measures to be employed, eg If an escort is in attendance.
3. **Aerodrome Maintenance Logbook.** Units **should** maintain an accurate Aerodrome Maintenance Logbook iaw RA 3204². Each WIP entry in the Aerodrome Maintenance Logbook **should** be signed by the individual who briefs the working party and by the working party manager to certify that the briefing has been fully understood.
4. **Control When WIP is within or close to a Landing Area.** When WIP is ►◄ carried out within the prescribed approach area or the landing area of the Runway or landing site in use, and it is not possible to stop flying, additional measures **should** be enforced to safeguard the working party and ►Aircraft◄. Where these additional measures include an escort, the escort **should** be properly briefed on:
 - a. Their responsibilities.
 - b. Any equipment they may be issued.
 - c. Methods of communication.

Guidance Material 3266(1)

Aerodrome Maintenance

5. Nil.

¹ Refer to ►RA 1026(4): Management of a Defence Aerodrome Manual and Defence Aerodrome Assurance Framework.◄

² Refer to RA 3204 – Air Traffic Management Records.

**Regulation
3266(2)****Work In Progress Map**

3266(2) Units **shall** maintain a WIP Map.

**Acceptable
Means of
Compliance
3266(2)****Work In Progress Map**

6. An accurate WIP map **should** be maintained and made available to Aerodrome users.

7. The map **should** provide Aerodrome users with visibility of where Maintenance is being conducted and, as a minimum, **should** contain:

- a. The nature and location of WIP.
- b. Dates WIP will be conducted.
- c. How any obstructions will be marked (day and night).

**Guidance
Material
3266(2)****Work In Progress Map**

8. Nil.

RA 3267 - Aerodrome Vehicle Marking and Lighting Requirements

Rationale

► *Specific vehicular movement on Aerodromes is essential to support Aerodrome operations. Incorrectly marked and / or lit vehicles increase Risk to Life during Aerodrome operations.* ◀ *Vehicles operating on Movement Areas* ► *therefore* ◀ *need to be* ► *appropriately marked and / or lit to ensure they are* ◀ *readily visible to Air Traffic Control (ATC) and Air System crews.*

Contents

3267(1): Aerodrome Vehicle Marking and Lighting Requirements

Regulation 3267(1)

Aerodrome Vehicle Marking and Lighting Requirements

3267(1) All vehicles operating regularly on the Movement Area of an Aerodrome **shall** have appropriate marking and lighting.

Acceptable Means of Compliance 3267(1)

Aerodrome Vehicle Marking and Lighting Requirements

1. With the exception of emergency vehicles, all vehicles¹ operating regularly within the Movement Area of an Aerodrome **should** be conspicuous in colour (ideally yellow) so as to be clearly seen from the air and from the ground.
2. Where vehicles will be used regularly on the Movement Area but are unable to meet the provisions of para 1 (ie Fuel Bowsers in Desert pattern), they **should** be clearly marked with yellow so as to be clearly visible from the ground and the air.
3. **Obstructions.** Vehicles which are defined as obstructions within the Runway, approach funnel or taxiway clearance areas² (eg Truck Runway ► **Control** ◀) **should** have their external vertical planes painted with a uniform red-and-white chequered pattern. The sides of the squares or near squares **should** be at least 1 m (3 ft) in size; the corners being in red, and the whole top surface yellow.
4. **Vehicle Lighting.** Vehicles regularly employed within the Aerodrome Movement Area **should** be equipped with the following lighting:
 - a. Occulting Blue:
 - (1) Ambulances (all types).
 - (2) Fire Vehicles (all types).
 - (3) Police Vehicles (all types).
 - b. Occulting Green:
 - (1) Medical officers' vehicles.
 - c. Flashing Amber:
 - (1) ► **Aircraft** ◀ Maintenance / towing vehicles.
 - (2) Snow clearance vehicles.
 - (3) Bulk gritter.
 - (4) ATC vehicles.
 - (5) Brake parachute recovery (various types).
 - (6) Runway sweeper.
 - (7) Vehicles used for Maintenance on the Aerodrome.
 - (8) Refuelling vehicles.
 - (9) Logistics / Movements vehicles (eg catering truck).
5. Where designated vehicles are not available (eg due to servicing), replacement vehicles **should** utilize Hazard warning lights.

¹ This does not include private vehicles used to travel to / from work locations.

² As defined in the ► **RA 3500 Series of Regulations: Aerodrome Design and Safeguarding.** ◀

**Guidance
Material
3267(1)**

Aerodrome Vehicle Marking and Lighting Requirements

6. **Emergency Vehicles.** Fire vehicles will be painted signal red (UK only).

RA 3268 – ► Aircraft ◄ Arresting Systems

Rationale

Aerodromes may be fitted with ► Aircraft ◄ Arresting Systems (► AAS ◄) to aid ► Aircraft ◄ in an emergency. ► Risk to Life could be increased if AAS are not operated correctly or if AAS readiness states are not understood ◄. Controllers and Aircrew need to be aware of the configuration and use of these ► AAS. ◄

Contents

3268(1): ► Aircraft ◄ Arresting Systems

3268(2): ► Aircraft ◄ Arresting Systems - Barriers - Controller Responsibilities

3268(3): ► Aircraft ◄ Arresting Systems - Cables - Controller Responsibilities

Regulation 3268(1)

► Aircraft ◄ Arresting Systems

3268(1) Unit orders **shall** detail the operational use of ► AAS. ◄

Acceptable Means of Compliance 3268(1)

► Aircraft ◄ Arresting Systems

1. Orders for the operational use of ► AAS ◄ **should** include operating procedures, Air Traffic Control (ATC) responsibilities and specific Aviation Duty Holder requirements.

Guidance Material 3268(1)

► Aircraft ◄ Arresting Systems

2. Details of ► AAS ◄ used on MOD Aerodromes can be found in the ► Regulatory Article 3500 Series¹. ◄

Regulation 3268(2)

► Aircraft ◄ Arresting Systems - Barriers - Controller Responsibilities

3268(2) Controllers **shall** pass the readiness state of the barriers when giving a clearance to use the runway.

Acceptable Means of Compliance 3268(2)

► Aircraft ◄ Arresting Systems - Barriers - Controller Responsibilities

3. Controllers **should** state barrier positions to ► Aircraft ◄ on take-off, landing, touch and go and low approach clearances. Unit Orders **should** define when readiness states are passed to locally based ► Aircraft ◄ if the barriers are in the published standard configuration.

4. When passing barrier states, the phraseology: 'barrier up', 'barrier down' or 'barrier unserviceable' **should** be used. In the case of the Mk 12A and Type B barriers this is to be followed by 'Light' or 'Heavy' as appropriate. Full phraseology is detailed in CAP 413, Radiotelephony Manual, Chapter 10.

5. Controllers **should** ensure that the approach barrier is down, and indicating down on the display, before clearing ► Aircraft ◄ for a take off, landing, touch and go or low approach.

6. Where controllers are unable to see the approach barrier and the display panel is unserviceable, suitable local arrangements **should** be made to ensure the approach barrier state is known to the controller prior to the issue of any clearance.

7. Unless demanded by operational circumstances, the barrier **should not** be left up when the wind component along the runway is either a steady 30 knots or gusts

¹ ► Refer to the RA 3500 Series: Aerodrome Design and Safeguarding. ◄

**Acceptable
Means of
Compliance
3268(2)**

above 35 knots. Experience has shown that higher wind speeds, especially when the net is wet, may cause the net to break free of the suspension cables².

8. In winter conditions, the net and superstructure **should** be kept free of frost, ice and snow using in-service approved fluid for the process and applied in accordance with current procedures³. This precaution, if required, **should** be carried out during the Before Use Servicing⁴.

**Guidance
Material
3268(2)**

► Aircraft ◀ Arresting Systems - Barriers - Controller Responsibilities

9. Authority to have the barrier raised to the up position is vested in the pilot, the officer in charge of flying or their deputy on duty in the control tower. The pilot is required to make the call 'Barrier! Barrier! Barrier!' if they require it during take-off or landing and it is not already in the fully raised position. The officer in charge of flying or their deputy on duty in the control tower can, at their discretion, order the barrier to be raised if they consider circumstances warrant its erection. This action is always to be accompanied by the message 'Barrier up'.

**Regulation
3268(3)**

► Aircraft ◀ Arresting Systems - Cables - Controller Responsibilities

3268(3) Controllers **shall** pass the readiness state of the cables when giving clearance to use the runway.

**Acceptable
Means of
Compliance
3268(3)**

► Aircraft ◀ Arresting Systems - Cables - Controller Responsibilities

10. Controllers **should** state cable position to ► Aircraft ◀ on take-off, landing, touch and go or low approach clearances. Full phraseology is detailed in CAP 413, Radiotelephony Manual, Chapter 10.

11. Unit orders **should** define when readiness states are passed to locally-based ► Aircraft ◀ if the cables are in the published standard configuration.

**Guidance
Material
3268(3)**

► Aircraft ◀ Arresting Systems - Cables - Controller Responsibilities

12. Recovery of ► Aircraft ◀ and arresting cables after an engagement can be hazardous to personnel. Medical cover may remain in the vicinity of the arresting cable until the rewind procedure is completed.

13. Only Suitably Qualified and Experienced Person (SQEP) ground engineers can declare an arresting cable serviceable for use.

14. Exceptionally, in the absence of SQEP ground engineers, Aerodrome Rescue Firefighters qualified to do so, may visually check the equipment for obvious unserviceability during the cable rewind following a cable engagement. Once ATC have been informed that the engagement weight and speed were within limits and that the equipment appears fit for use, the arresting cable may be used for one further emergency arrest.

15. Some ► Aircraft ◀ are cleared to trample the cables when they are up and others only when they are down. It is a pilot's responsibility to notify ATC whether or not the ► Aircraft ◀ is cleared to trample the cables in the notified position.

16. When a cable is in a non-standard configuration, and unit ► Aircraft ◀ are carrying out a series of approaches, warning of its position is only required once rather than on each approach.

² Refer to ► AP 119J-1406-12 ◀ (Aircraft Arresting Barriers Types A and B) Chap 6, para 3.

³ Refer to ► AP 119J-1406-12 ◀ Ch 6, para 2.

⁴ In accordance with AP 119J-1406-5F.

► This RA has been substantially re-written; for clarity no change marks are presented – please read RA in its entirety ◀

RA 3269 – Use of Pyrotechnics, Firearms and Lasers to Support Aerodrome Operations

Rationale

Air Traffic Control (ATC) and Airfield Wildlife Control Unit (AWCU) personnel may, in the course of their duties, be required to operate pyrotechnics, firearms and lasers to support Aerodrome operations. Inappropriate use of pyrotechnics, firearms or lasers could cause distraction for pilots and Controllers and inadvertently increase Risk to Life. The appropriate, safe and controlled use of pyrotechnics, firearms and lasers, by suitably trained personnel, will support the provision of a Safe Operating Environment.

Contents

3269(1): Use of Pyrotechnics, Firearms and Lasers to Support Aerodrome Operations

Regulation 3269(1)

Use of Pyrotechnics, Firearms and Lasers to support Aerodrome Operations

3269(1) Only Suitably Qualified and Experienced Persons (SQEP) **shall** use pyrotechnics, firearms and lasers.

Acceptable Means of Compliance 3269(1)

Use of Pyrotechnics, Firearms and Lasers to support Aerodrome Operations

1. Commanders **should** ensure that all ATC staff¹ (and AWCU staff, if established) are qualified, in date and competent prior to the use of any pyrotechnic device, firearm or laser.
2. Commanders **should** ensure, and record, that all ATC staff¹ meet the mandatory criteria for the use of pyrotechnics and firearms as follows:
 - a. **Formally Trained.** Trained by a qualified and competent instructor² in accordance with (iaw) the appropriate Service training publication.
 - b. **Formally Tested.** Passed Weapon Handling Test, conducted by a qualified and competent instructor, within the qualifying period and periodically thereafter iaw single Service (sS) requirements. Where applicable, live firing or observation of live firing **should** be completed within the required qualifying period.
3. AWCU staff **should** be trained, tested and periodically assessed by an appropriate authority iaw contract requirements.
4. Commanders **should** ensure that AWCU staff hold the appropriate licences for the weapons and ammunition to be used.
5. Commanders **should** ensure that the use of lasers for wildlife control purposes, by ATC staff¹ (and AWCU staff, if established), is approved by the Unit Laser Safety Officer and carried out iaw the applicable Defence Ordnance, Munitions & Explosives Safety Regulator (DOSR) regulatory publications.

Guidance Material 3269(1)

Use of Pyrotechnics, Firearms and Lasers to support Aerodrome Operations

6. Information on the training requirements and use of pyrotechnics and firearms, including operating information and training policy, may be obtained from sS Headquarters, unit armoury staff and Small Arms training establishments.

¹ This includes both military and civilian staff.

² For example, a Skill at Arms Instructor or Weapons Instructor.

**Guidance
Material
3269(1)**

7. Regulations for, and information on, the safe operation of weapons, including lasers, is available from DOSR, JSP440 and the Military Laser Safety Team.

RA 3270 - Aerodrome Wildlife Control

Rationale

Wildlife poses a Hazard to ►Aircraft◄ operations, especially close to Aerodromes when ►Aircraft◄ are in the critical stages of flight. ►The presence of wildlife on or around an Aerodrome has the potential to cause Accidents and wildlife strikes result in Aircraft damage.◄ Effective methods of wildlife control are ►therefore◄ required ►to reduce Risk to Life.◄

Contents

3270(1): Aerodrome Wildlife Control

Regulation 3270(1)

Aerodrome Wildlife Control

3270(1) Heads of Establishments and Aviation Duty Holder-Facing organizations **shall** ensure that units have an Aerodrome Wildlife Control Management Plan (AWCMP).

Acceptable Means of Compliance 3270(1)

Aerodrome Wildlife Control

1. An AWCMP **should** assess the potential wildlife strike¹ Hazard and define and implement appropriate wildlife control measures to reduce or mitigate the Hazard. This assessment **should** be conducted through safety management procedures² and be published in the Defence Aerodrome Manual³.
2. The aim of an AWCMP **should** be to reduce wildlife infestation on the Aerodrome and to monitor and assess wildlife strike events.
3. Where an Aerodrome Wildlife Control Unit (AWCU) is established, the AWCU **should**, by means of observation, recording, reporting and survey, assess the local wildlife population⁴, its habits and the effect on ►Aircraft◄ flying at or near that Aerodrome and take appropriate action to reduce the Hazard.
4. At Aerodromes where there is no AWCU, Commanders **should** appoint an Aerodrome Wildlife Control Officer to coordinate wildlife control activities as identified in the AWCMP.

Guidance Material 3270(1)

Aerodrome Wildlife Control

5. **Statutory Safeguarding.** A safeguarding consultation process exists as part of the planning process to address proposed developments with the potential to affect the safety of ►Aircraft◄ operations at certain military Aerodromes. The consultation process includes a means to address potential wildlife attractant developments within an 8 statute mile radius of the centre point of the runway ends (not including stopways and clearways) of declared Aerodromes. Safeguarding maps (Plan B)⁵ are used to define the 8 statute mile radius circle and are lodged with local planning authorities. The 8 statute mile circle is based on a statistic that the majority of bird strikes occur below a height of 2000 ft, and that an ►Aircraft◄ on a normal approach would descend into this circle at approximately this distance from the runway.
 - a. Not all MOD Aerodromes have, or require, a standard 8 statute mile radius Plan B. Units are responsible for ensuring that the necessary level of safeguarding is in place for their task / facility and can contact Defence Infrastructure Organisation (DIO) Safeguarding⁶ to confirm appropriate safeguarding levels and consultation procedures are in place.
 - b. Ideally, informal consultations on a potential bird attractant development will take place between applicants and DIO Safeguarding before the submission of a planning application. This may make it easier to achieve a mutually

¹ In accordance with UK National Regulation, the subject matter is referred to as 'wildlife' however the term 'birdstrike' is still acceptable.

² As detailed in RA 1200 – Air Safety Management and the Manual of Air Safety.

³ Refer to RA 1026 – Aerodrome Operator and Aerodrome Supervisor (Recreational Flying) Roles and Responsibilities ►◄.

⁴ For birds out to the extent of the bird safeguarding zone – usually 13 km.

⁵ Refer to RA 3590 – Maintenance and Safeguarding.

⁶ DIO-Safeguarding-Statutory@mod.gov.uk.

**Guidance
Material
3270(1)**

acceptable outcome with regard to wildlife control. The following factors will be taken into consideration when assessing the potential increase in risk:

- (1) Location - the proximity of the development relative to the ► **Aircraft** ◀ arrival and departure flightpaths and within the visual circuit.
- (2) The numbers, including seasonal variations, size and types of birds that may be attracted to the development.
- (3) The site attractiveness - whether it is used as a source of food, a roost or nesting site, any proposed landscaping or habitat designs.
- (4) Bird flightlines to / from the site in relation to the Aerodrome - whether flightlines are direct to the Aerodrome, across the ► **Aircraft** ◀ flightpaths outside the Aerodrome boundary, above the Aerodrome or not across the Aerodrome / flightpaths; for example, waterfowl move primarily between wetlands and along watercourses. Creating new bodies of water may cause more waterfowl movements and the increase of bird strike risk.
- (5) Any control action undertaken by the site operator - actions may range from no action to housekeeping actions only, passive and active bird scaring measures to culling.
- (6) Daily / seasonal factors - whether the site is a continuous Risk (each day and throughout the day), a regular daily risk (once / twice a day), a Risk related to specific daily or seasonal activities, or an annual Risk.

c. Where an assessment shows that the bird strike risk may increase or could increase under certain conditions in the future, and the Authority and developer are unable to agree a solution, the MOD could object to the planning application on safety grounds. The MOD may use local knowledge of bird populations and activities or an appropriate precedent of a similar safeguarding case to support the objection and may request that the objection cannot be withdrawn until measures to ensure there will be no increase in Risk are implemented. It may be possible to modify a development (eg exclusion of food wastes from a new landfill) or impose planning conditions that require specific action to exclude birds or reduce their numbers; eg an effective Bird Control Management Plan (BCMP)⁷. Where a safeguarding case is resolved through the imposition of planning conditions, it may be appropriate for the conditions (and a BCMP) to be subject to a legal agreement between the planning authority and the developer or property owner, or its successors.

d. A development BCMP will identify the Aerodrome personnel holding responsibility for the assessment of a proposed development with the potential to attract birds (this would normally be coordinated through DIO Safeguarding).

e. After planning permission has been granted, the Aerodrome will monitor the development for compliance with any planning conditions that are imposed and report any alleged breach or non-compliance to DIO Safeguarding via the appropriate authority.

6. **Aerodrome Grass Management.** Aerodromes naturally offer birds food and / or security for foraging, resting and, sometimes, breeding. While the employment of a AWCU may remove birds from the Aerodrome, the birds will return for as long as the attraction remains. One significant measure that may be employed is to manage the grassed areas to maintain an erect and dense 'long grass' sward. Units may take advice from their contracted AWCU and / or DIO on the optimal grass length for their Aerodrome and its usage, taking into account the type of grass present and the type of birds that most commonly inhabit it. Units may refer to CAP 772⁸◀ for further information on Aerodrome grass management.

a. Some Aerodromes may contain Sites of Special Scientific Interest (SSSIs) or other Nature Conservation designation areas which may influence the grass regime adopted. Further, any proposed major changes to habitat will

⁷ Associated with the development, rather than the aerodrome.

⁸ ► Refer to CAP 772: Wildlife Hazard Management at Aerodromes. ◀

**Guidance
Material
3270(1)**

require a Sustainability Appraisal to ensure compliance with legislation and MOD policy. Advice can be sought from the DIO Environmental Support Team. JSP 850⁹ provides direction on the management of SSSIs.

b. The Environment Agency may impose restrictions on the use of certain fertilizers, herbicides and pesticides due to the potential pollution of water course, catchments or tables. Specialist advice must be sought from the appropriate authority before proceeding.

7. Units may utilize CAP 772⁸ to assist in the development of an AWCMP.

⁹ ▶ Refer to JSP 850 - Part 2 Estate Management - Biodiversity and Natural Capital. ◀

Intentionally Blank for Print Pagination

► This RA has been substantially re-written; for clarity no change marks are presented – please read RA in its entirety ◀

RA 3272 – Evaluation of Runway Surface Conditions

Rationale

Runway surface conditions, including friction qualities, are subject to change due to the continuous use of the surface over time by Aircraft and / or weather. Continuous use and / or weather can cause doubt to exist over the Runway surface braking conditions. To ensure the safe operation of Aircraft, the condition of the Runway needs to be evaluated regularly and reported as appropriate in order to reduce Risk to Life.

Contents

3272(1): Continuous Friction Measuring Equipment

3272(2): Reporting of Runway Surface Conditions

Regulation

3272(1)

Continuous Friction Measuring Equipment

3272(1) Continuous Friction Measuring Equipment (CFME) **shall** be used in specific circumstances.

Acceptable Means of Compliance 3272(1)

Continuous Friction Measuring Equipment

1. CFME **should** only be used for Friction tests, and in extremis on runways contaminated with compacted snow and ice. CFME, such as Griptester and Mu-meter, are considered unreliable on Runways contaminated with wet snow, slush or water and may indicate a surface condition that is better than the actual condition.
2. **Contaminated Runway**¹. Contaminated Runway conditions **should** be reported detailing the contamination for each third of the Runway as detailed in RA 3272(2).
3. Friction tests **should** be completed utilizing CFME:
 - a. If doubt exists as to the braking conditions of the Runway, except on a contaminated Runway².
 - b. Following an Aircraft Incident / Accident on the Runway, where a possibility exists that the surface conditions may have been a contributing factor, a full evaluation of those sections of the Runway considered to be associated with the Incident / Accident **should** be carried out, in accordance with (iaw) the Post Crash Management procedures contained in the Manual of Aircraft Post Crash Management. Records of readings and traces **should** be retained iaw with RA 3204³.
 - c. When required as part of an Aerodrome preventive and corrective Maintenance programme iaw RA 3590(2)⁴.
4. A friction test, with the exception of those conducted as part of an Aerodrome preventive and corrective Maintenance programme⁴, **should** consist of:
 - a. One run over the usable length of the Runway on a line between 2 m and 10 m each side of the centreline.
 - b. Additional runs at varying distances from the centreline **should** be conducted where poor areas are known to exist, or to cover Aircraft formation operations.
5. Mean values **should** be recorded for each third of the Runway length available.

¹ Refer to Annex A Table 2. Reporting Terms for definition.

² Other than a Runway contaminated with compacted snow and ice.

³ Refer to RA 3204 – Air Traffic Management Records.

⁴ Refer to RA 3590(2): Maintenance – Pavements – Friction.

**Acceptable
Means of
Compliance
3272(1)**

6. A plan of the Runway(s) **should** be maintained by Air Traffic Control (ATC) showing where pooling occurs and where areas of low friction caused by rubber deposits, Runway markings etc exist, especially if a recurring equivalent coefficient reading of 0.35 or below is recorded. If this is the case the Defence Infrastructure Organisation **should** be advised.
7. A record **should** be kept by ATC of all evaluation monitoring runs. A copy of the rainfall trace for the day **should** be attached to the record. If the rainfall trace is not available a full rain report for the day **should** be requested and attached to the record.

**Guidance
Material
3272(1)**

Continuous Friction Measuring Equipment

8. Nil.

**Regulation
3272(2)**

Reporting of Runway Surface Conditions

- 3272(2) Deteriorating and / or changing Runway surface conditions **shall** be reported iaw the International Civil Aviation Organization's Global Reporting Format (GRF)⁵.

**Acceptable
Means of
Compliance
3272(2)**

Reporting of Runway Surface Conditions

9. The Aerodrome Operator (AO) **should** be responsible for assessing Aerodrome surface conditions and disseminating Runway surface conditions. However, in practice, arrangements can be made for the assessment and dissemination of Runway surface conditions to be delegated to the Air Traffic Services (ATS) unit and / or Station Operations.

10. Reporting, in compliance with the Runway Condition Report (RCR), **should** commence when a significant change in Runway surface condition occurs due to water, snow, slush, ice or frost. Reporting of the Runway surface condition **should** continue to reflect significant changes until the Runway is no longer contaminated. When this situation occurs, the Aerodrome **should** issue a RCR that states the Runway is wet or dry as appropriate.

11. RCRs **should** be reported on the Automatic Terminal Information System (ATIS). If ATIS is not available or significant changes occur, this information **should** be reported by ATC to Aircraft concerned in plain language on the radiotelephony (RTF) either:

- a. Individually, or
- b. Via the use of an all-stations broadcast, obtaining acknowledgement from each of the Aircraft concerned.

12. When reported, the presence or otherwise of contaminants on the surface of a Runway **should** be assessed over the most significant portion of the Runway, ie the area most likely to be used by Aircraft taking-off and landing. The assessed area may be different on Runways with a displaced threshold or other unusual configuration. The AO **should** be responsible for determining the exact dimensions and location of the area that is assessed.

13. Reports of the runway condition, to be used on ATIS or RTF for each third **should** be given in the direction of take-off or landing. Reports on the Runway surface condition **should** include the Aerodrome location, the date and time of assessment and the Runway-in-use designator followed as applicable by the elements below (associated phraseology is contained within CAP 413⁶):

- a. Runway Condition Code (RWYCC) for each Runway third;
- b. Type of contaminant;
- c. Depth of contaminant;

⁵ Refer to CAP 493 – Manual of Air Traffic Services – Part 1.

⁶ Refer to CAP 413 – Radiotelephony Manual

**Acceptable
Means of
Compliance
3272(2)**

- d. Percentage coverage of contaminant;
- e. Available width and / or length (if less than published); and
- f. Other related information.

14. **Unofficial Observations:** Pilots of Aircraft may report, or observations from the Visual Control Room (VCR) may indicate, that the amount of contaminant water present or Runway surface condition is different from that being reported. Under no circumstances **should** a Controller pass pilot's information which suggests that the Runway surface condition is better than the official report. However, when a pilots report or an observation from the VCR indicates a worse Runway surface condition, this information **should** be passed to other Aircraft.

- a. Unofficial observations from the VCR or pilot reports **should** be prefixed by the words "Unofficial observation". In this case, the Runway surface conditions will be advised using a single term for the entire Runway.

15. Pilot reports of braking action **should** be passed to the AO⁷ as soon as practicable to enable the AO⁷ to consider reassessing the RWYCC. The use of downgrading / upgrading is discouraged in the UK but AOs at Aerodromes outside of the UK considering the process **should** follow the procedure in CAP 2179⁸.

16. GRF is only applicable to paved surfaces and **should not** be used for grass / natural surface Runways.

17. In reporting the surface condition of a grass Runway, the report relates to the whole of the surface, and not to individual thirds. When the surface condition of a grass Runway or grass taxiway is assessed as being WET or CONTAMINATED a RWYCC **should not** be passed. Instead, its condition together with any other related information, is to be reported on the RTF to each Aircraft concerned and, where appropriate, on the ATIS in plain language using the descriptions contained in Annex A Tables 2 – 4.

**Guidance
Material
3272(2)**

Reporting of Runway Surface Conditions

18. Aircraft performance can be considered to be impacted whenever the coverage of any water-based contaminants on any Runway third exceeds 25 per cent. GRF standardizes the assessment and reporting procedures to ensure that Runway surface conditions impacted by any contamination are communicated to Aircraft operators in a manner consistent with the effect on Aircraft performance. There are 5 fundamental elements of the methodology for the reporting and assessment of Runway surface conditions; these are:

- a. RCR: Is used by pilots to inform their Aircraft performance calculations and to provide them with situational awareness. The data contained within the RCR originate from the elements below:
- b. Runway Condition Assessment Matrix (RCAM): The matrix is used by the AO's personnel conducting Runway surface assessments to determine the appropriate RWYCC for each third of the Runway, and for pilots to decode the RWYCC into meaningful performance information (See Annex A Table 1).
- c. RWYCC: The RWYCC is determined through the assessment of the following aspects:
 - (1) Percentage of coverage of contamination in each Runway third; Type of contaminant, selected from the Runway Surface Conditions (see Annex A Table 2) and Runway Surface Condition Descriptors (see Annex A Table 3);
 - (2) Depth of the contamination; and
 - (3) Outside Air Temperature (OAT).
- d. Runway Surface Conditions (Reporting term) (See Annex A Table 2) and,

⁷ Or the delegated ATS unit and / or Station Operations.

⁸ Refer to CAP 2179 – Global Reporting Format: Guidance to Aerodrome Operators on How to Respond to Changing Conditions.

**Guidance
Material
3272(2)**

e. Runway Surface Condition Descriptors (see Annex A Table 3).

19. The RCAM enables Aerodrome personnel to make an assessment based on visual observation of contaminants on the Runway surface, specifically the contaminant type, depth and coverage, as well as the OAT. The assessment information is used to develop the RCR. Once promulgated, there is an operational need for the information in the RCR to be kept up to date and accurate. Consequently, for the Aerodrome personnel monitoring and reporting the Runway surface conditions, it is important to focus on identifying and reporting any significant changes whenever they occur. A significant change is a change that requires new information in any item of the RCR.

20. Further details regarding Runway surface condition assessments can be found in CAP 2174⁹.

21. Throughout the weather event, it is expected the AO will maintain the accuracy of the RCR through reassessment as the conditions change and issue a new RCR if any of the reported items change. The use of Downgrading and Upgrading is discouraged as they relate to a specific process not designed or expected to be used in the UK iaw CAP 2179⁸

Civil Equivalence

22. This regulation is in line with CAP 493 – Manual of Air Traffic Services Part 1.

⁹ Refer to CAP 2174 – Assessment, Measurement and Reporting of Runway Surface Conditions for Licensed Aerodromes.

ANNEX A

EVALUATION / REPORTING OF RUNWAY SURFACE CONDITIONS

Table 1. Runway Condition Assessment Matrix

| Runway Condition Assessment Matrix | | | |
|------------------------------------|---|--|---------------------------------------|
| Assessment Criteria | | Downgrade Assessment Criteria | |
| Runway Condition Code | Runway Surface Description | Aircraft Deceleration or Direction Control Observation | Pilot Report of Runway Braking Action |
| 6 | <ul style="list-style-type: none"> • DRY | - | - |
| 5 | <ul style="list-style-type: none"> • FROST • WET (The Runway surface is covered by any visible dampness or water up to and including 3 mm depth) <p>Up to and including 3 mm depth:</p> <ul style="list-style-type: none"> • SLUSH • DRY SNOW • WET SNOW | Braking deceleration is normal for the wheel braking effort applied and direction control is normal. | GOOD |
| 4 | <p>-15°C and colder OAT:</p> <ul style="list-style-type: none"> • COMPACTED SNOW | Braking deceleration OR Directional control is between Good and Medium. | GOOD to MEDIUM |
| 3 | <ul style="list-style-type: none"> • WET ("slippery wet" Runway) • DRY SNOW or WET SNOW (any depth) ON TOP OF COMPACTED SNOW <p>More than 3 mm depth:</p> <ul style="list-style-type: none"> • DRY SNOW • WET SNOW <p>Warmer than -15°C OAT:</p> <ul style="list-style-type: none"> • COMPACTED SNOW | Braking deceleration is noticeably reduced for the wheel braking effort applied OR Directional control is noticeably reduced. | MEDIUM |
| 2 | <p>More than 3 mm depth of water or slush:</p> <ul style="list-style-type: none"> • STANDING WATER • SLUSH | Braking deceleration OR Directional control is between Medium and Poor. | MEDIUM to POOR |
| 1 | <ul style="list-style-type: none"> • ICE | Braking deceleration is significantly reduced for the wheel braking effort applied. OR Directional control is significantly reduced. | POOR |

| | | | |
|---|---|--|----------------|
| 0 | <ul style="list-style-type: none"> • WET ICE • WATER ON TOP OF COMPACTED SNOW • DRY SNOW or WET SNOW ON TOP OF ICE | <p>Braking deceleration is minimal to non-existent for the wheel braking effort applied</p> <p>OR</p> <p>Directional control is uncertain.</p> | LESS THAN POOR |
|---|---|--|----------------|

Table 2. Reporting Terms

| Reporting Term | Runway Surface Conditions |
|----------------|---|
| DRY | The Runway surface is considered dry if it is free of visible moisture and not contaminated within the area intended to be used. |
| WET | <p>The Runway surface is covered by any visible dampness or water up to and including 3 mm depth within the intended area of use.</p> <p>Note:</p> <p style="padding-left: 40px;">If the surface shows a change of colour due to moisture, the Runway will be reported as wet.</p> |
| SLIPPERY WET | A wet Runway where the surface friction characteristics of a significant portion of the Runway have been determined to be degraded. |
| CONTAMINATED | A Runway is considered to be contaminated when a significant portion of the Runway surface area (whether in isolated areas or not) within the required length and width being used, is covered by one or more of the substances listed in the Runway surface condition descriptor table (see Table 3). The term 'CONTAMINATED' should not be used in RTF phraseology, the Runway surface condition descriptors (see Table 3) are to be used. |

Table 3. Runway Surface Condition Descriptor

| Runway Surface Condition ^a Descriptor | |
|--|---|
| COMPACTED SNOW | Snow that has been compacted into a solid mass such that Aircraft tyres at operation pressure and loadings, will run on the surface without significant further compaction or rutting of the surface. |
| DRY SNOW | Snow from which a snowball cannot readily be made. |
| FROST | <p>Frost consists of ice crystals formed from airborne moisture on a surface whose temperature is below freezing. Frost differs from ice in that the frost crystals grow independently and therefore have a more granular texture.</p> <p>Note:</p> <ol style="list-style-type: none"> 1. Below freezing refers to air temperature equal to or less than the freezing point of water (0°C). 2. Under certain conditions frost can cause the surface to become very slippery and it is then reported appropriately as reduced braking action. |
| ICE | Water that has frozen or compacted snow that has transitioned into ice, in cold and dry conditions. |
| SLUSH | Snow that is so water-saturated that water will drain from it when a handful is picked up or will splatter if stepped on forcefully. |
| STANDING WATER | Water of depth greater than 3 mm. |

| | |
|--|--|
| WET ICE | Ice with water on top of it or ice that is melting. Note: Freezing precipitation can lead to Runway conditions associated with wet ice from an Aircraft performance point of view. Wet ice can cause the surface to become very slippery. |
| WET SNOW | Snow that contains enough water content to be able to make a well compacted, solid snowball, but water will not be squeezed out. |
| <p>^a In providing information on Runway surface conditions, many of the terms described above may be used in combination as follows: DRY SNOW ON TOP OF COMPACTED SNOW, DRY SNOW ON TOP OF ICE, WATER ON TOP OF COMPACTED SNOW, WET SNOW ON TOP OF COMPACTED SNOW and WET SNOW ON TOP OF ICE.</p> | |

Table 4. Other Related Information

| <i>Other Related Information</i> |
|--|
| <p>For example, provide details of any:</p> <ul style="list-style-type: none"> • Runway de-icing activity that has taken place, such as chemical treatment. • Provide details of any snowbanks on the Runway giving the distance left / right from the Runway centreline. • Frozen ruts and ridges. |

Intentionally Blank for Print Pagination

RA 3273 – Aerodrome Traffic Monitor

Rationale *Controllers require situational awareness of Air Systems in the vicinity of an Aerodrome in order to assist them in facilitating a safe and expeditious flow of air traffic.*

Contents **3273(1): Aerodrome Traffic Monitor**

**Regulation
3273(1)**

Aerodrome Traffic Monitor

3273(1) Controllers **shall** only use the Aerodrome Traffic Monitor¹ for defined purposes.

**Acceptable
Means of
Compliance
3273(1)**

Aerodrome Traffic Monitor

1. Controllers **should** use the Aerodrome Traffic Monitor in order to:
 - a. Determine the landing order, spacing and distance from touchdown of Air Systems. Air Systems performing an instrument approach **should** be identified from final approach liaison calls.
 - b. Provide information on the position of Air Systems within the circuit. However, such information should normally be derived from lookout or normal circuit management techniques.
 - c. Monitor the position of notified transit traffic and, subject to prior agreement with appropriate surveillance controllers, apply or cancel climb-out restrictions accordingly. This procedure **should** be defined in Local/Unit Orders.
2. Where the controller feels that there is a definite risk of collision, they **should** use the Aerodrome Traffic Monitor to pass Traffic Information.

**Guidance
Material
3273(1)**

Aerodrome Traffic Monitor

3. Nil.

¹ An Aerodrome Traffic Monitor is a screen providing a replica radar screen; it may be of various makes.

Intentionally Blank for Print Pagination

RA 3274 - Low Visibility Procedures

Rationale

Air System operations during reduced visibility or low cloud conditions create additional operating hazards and require measures to mitigate the associated hazards.

Contents

3274(1): Low Visibility Procedures

Regulation

3274(1)

Low Visibility Procedures

3274(1) Aviation Duty Holders (ADH) and Heads of Establishment (HoE) **shall** have Low Visibility Procedures (LVP) at aerodromes that operate in weather conditions where Air Traffic Control (ATC) are not always able to maintain full visual control of the Movement Area.

Acceptable Means of Compliance 3274(1)

Low Visibility Procedures

1. Aerodrome operators **should** develop LVP utilizing extant safety management processes¹ in order to limit unnecessary access to the Movement Area, determine the movement rate that can be sustained and the LVP that will adequately support this rate.
2. **Visibility Conditions.** The point at which LVP are initiated will vary from aerodrome to aerodrome and **should** be clearly defined in relation to Runway Visual Range (RVR) / visibility conditions, as detailed in RA 3275▶2◀.
3. **Declaration of LVP in Force.** It is essential that all LVP measures be verified as in place before LVP are declared to be in force by ATC. In the event of suitable gaps in flying operations, some LVP measures can be relaxed to allow efficient use of resources; such procedures **should** be detailed in Local / Unit orders³. All LVP measures **should** be verified as in place prior to the resumption of flying operations. When flying is in progress, LVP **should** be declared as cancelled before the aerodrome operator withdraws any measures.
4. **Conversion of Reported Meteorological (Met) Visibility to RVR.** At aerodromes where RVR measurements are not made, or in case of unserviceability of RVR measuring equipment, LVP **should** include criteria for implementation and withdrawal based on the reported Met visibility².
5. **Aerodrome and Runway Incursions.** It is accepted that during periods of low visibility the likelihood of aerodrome and runway incursion may be increased. Personnel **should** report all aerodrome and / or runway incursions in accordance with (iaw) RA 1410▶4◀.
6. **Precision Instrument Approach LVP Operations.** As the RVR deteriorates to the minimum at which Category (Cat) I precision approaches can be made (typically below 600 m but the exact value is determined by a variety of factors), or the cloud ceiling reduces to 200 ft, the withdrawal of non-essential vehicles and personnel from the Manoeuvring Area **should** be completed.
7. **Approach End Barrier**⁵. In low visibility conditions, the ability of aircrew or ATC to recognise that the approach end barrier has been inadvertently raised is significantly diminished. Consequently, and despite the presence of alarm systems, when LVP are declared, the approach end barrier **should** be isolated.
8. **Wildlife Control Operations.** Wildlife control operations **should** continue during LVP, but procedures **should** ensure that adequate time between movements is afforded to permit wildlife control measures to be implemented iaw RA 3270▶6◀.

¹ Refer to RA 1200 – Air Safety Management.

² ▶Refer to RA 3275 – Runway Visual Range. ◀

³ Military variance is less stringent than civilian equivalent for continuous LVP in CAP 168 - Licensing of Aerodromes.

⁴ ▶Refer to RA 1410 – Occurrence Reporting and Management. ◀

⁵ Refer to RA 3268 – Air System Arresting Systems.

⁶ ▶Refer to RA 3270 – Aerodrome Wildlife Control. ◀

**Guidance
Material
3274(1)**

Low Visibility Procedures⁷

9. Visibility Conditions – Guidelines:
- a. **Visibility Condition 1.** Is defined as visibility sufficient for the pilot to taxi and to avoid collision with other traffic on taxiways and at intersections by visual reference and for ATC personnel to exercise control over all traffic on the basis of visual surveillance. No additional requirements for the protection of ground operations by Air Systems are required.
 - b. **Visibility Condition 2.** Is defined as visibility sufficient for the pilot to taxi and avoid collision with other traffic on taxiways and at intersections by visual reference, but insufficient visibility for ATC to control traffic by visual surveillance. The actions required will be dependent on the dimensions of the Movement Area and position of the Visual Control Room (VCR):
 - (1) Procedures and visual aids will allow the pilot to determine ► their ◀ position and follow the required route. However, measures will need to be put in place to limit the potential for undetected aerodrome incursions, such as limited taxi routing, Surface Movement Radar (SMR) and stop-bars or physical barriers at runway access points.
 - (2) When the visibility decreases to a value equivalent to 1000 m RVR, and is expected to fall further, the withdrawal of vehicles and personnel involved in construction, Maintenance and other non-essential activities on the Manoeuvring Area will normally be initiated. Routine Maintenance on visual and non-visual aids may be suspended and the Instrument Landing System (ILS) and / or Precision Approach Radar (PAR) Sensitive Area will be cleared of all traffic.
 - (3) As the RVR deteriorates to 600 m, or the cloud ceiling reduces to 200 ft, all activities on the Manoeuvring Area will be brought under specific control by ATC (eg all activities subject to individual clearances as opposed to unrestricted movement).
 - c. **Visibility Condition 3.** Is defined as visibility equivalent to an RVR of less than 400 m. In such visibility conditions it is likely to be necessary to restrict further the operation of vehicles and persons on the Movement Area and initiate stringent control measures in response to the individual unit requirement.
10. **Hazards.** The following scenarios may be considered during the safety management process to ensure that the hazards associated with LVP are managed appropriately:
- a. Human error leads to an Air System using the Runway whilst it is occupied by another Air System, vehicle or pedestrian that may be unsighted due to low visibility.
 - b. The Air System uses the Runway whilst wildlife or Foreign Object Damage / Debris (FOD) is undetected on the surface due to low visibility.
 - c. Air Systems operating on taxiways / dispersals / aprons are unable to apply adequate separation from other Air Systems and / or vehicles due to low visibility.
 - d. Inadvertent barrier selection whilst an Air System is on final approach, undetected due to low visibility.
 - e. Delayed aerodrome rescue and fire fighting (ARFF) response to an Air System incident or accident due to low visibility. Although it is unlikely that ARFF response time will be significantly affected in visibilities down to 200 m, temporary relocation of vehicles to strategic points may be necessary for a large or complicated aerodrome. In visibility below 200 m there is greater probability that response times will be affected.

⁷ CAP 168 Appendix 2B Low Visibility Operations and ICAO Doc 9476 Manual of Surface Movement and Guidance Control Systems, Ch 5. EASA EU139/2014 Annex II Part-ADR also refers.

**Guidance
Material
3274(1)**

11. **Vehicular and Air System Controls.** The following control measures may be considered:
- a. Reducing vehicular access and use of the Movement Area. This could be introduced in stages as weather conditions deteriorate, and may include the suspension of non-essential working parties on the Aerodrome at an appropriate point or temporarily closing defined parts or all of the Movement Area to vehicular traffic.
 - b. The enforcement of positive control measures for essential aerodrome vehicles, following the suspension of non-essential activity, to include: positive radiotelephony (RT) clearances before entry onto the Movement Area; and subsequent separation of vehicles and Air System movements through positive control:
 - (1) By informing vehicles and Air Systems of each other's presence, or;
 - (2) Only allowing one Air System or vehicle on segmented sections of the Movement Area at a time.
 - c. The enforcement of vehicles to use dipped headlights when LVP are declared and the application of appropriate reduced speed limits.
 - d. Applying a simplified taxi pattern where possible, restricting the use of crossing or converging active taxiways, back-tracking of runways etc.
 - e. Reducing the number of Air Systems on the Manoeuvring Area at the same time, alternatively, the Manoeuvring Area could be segmented with only one Air System / vehicle allowed into each segment at a time, using taxi / driving clearance limits.
 - f. The use of a 'follow me' vehicle to guide Air Systems to or from the Runway to reduce the potential for aircrew to take incorrect routings. This could be applied to all Air System movements or limited only to unfamiliar visiting Air System. This measure is particularly relevant at aerodromes with complicated taxi patterns and increased potential for error.
 - g. Increased vehicular inspections of the Runway to reduce the potential for unknown obstructions or FOD to be on the surface.
 - h. Vehicles positioned at runway threshold holding points and key holding / crossing points to help prevent runway incursions and to promptly report those that do occur to ATC.
12. **SMR.** SMR may be provided at aerodromes with instrument approach aids that enable operations in RVR conditions below 550 m⁸. Unless procedures limit the number of Air Systems either on the Manoeuvring Area or on final approach within 5 nm, to one at any given time, and robust physical and procedural measures are in place to control the access of vehicles onto the Movement Area.
13. At aerodromes that are limited by instrument approaches with minimum RVR conditions of 550 m, SMR may still be required and may be considered where traffic density and operating conditions are such that acceptable levels of safety cannot be provided by alternative procedures and physical measures.
14. **Stop-Bar Lighting.** Stop-bars are highly effective in RVR conditions of less than 800 m, however the use of stop-bars in all lighting conditions is to be considered, as runway incursions are not limited to low visibility conditions. Aerodromes with Cat I and Cat II precision instrument approaches or take-off in RVR less than 800 m may consider the benefits of installing stop-bar lighting systems to enhance the effectiveness of their LVP. The specification for stop-bar lighting is detailed in RA 3515(18)⁹.
15. **Runway Guard Lights.** Runway Guard Lights are highly effective in RVR conditions less than 1200 m, however the use of Runway Guard Lights in all lighting

⁸ ICAO Annex 14 currently recommends the provision of SMR at aerodromes where operations in RVR less than 400 m take place. Multilateration based systems are an acceptable alternative within Surface Movement Guidance and Control Systems (SMGCS).

⁹ ► Refer to ◀ RA 3515(18): Taxiway Lights – Stop Bar Lights.

**Guidance
Material
3274(1)**

conditions is to be considered, as runway incursions are not limited to low visibility conditions. Aerodromes with Cat I and Cat II precision instrument approaches, non-precision approaches or take-off in RVR less than 1200 m may consider the benefits of installing Runway Guard Lights to enhance the effectiveness of their LVP. The specification for Runway Guard Lights are detailed in RA 3515▶◀¹⁰.

Runway Incursions and Aerodrome Movement Area Incursion. These are defined in MAA 02▶¹¹◀.

16. **Protected Area.** A surface designated for the landing and take-off of the Air System. This is to be interpreted as the runway strip up to and including holding points appropriate to the type of runway. It also refers to those portions of an aerodrome used for the take-off and landing of Air Systems, such as flight decks and helicopter operation areas, other than designated runways. This will, in addition, include instrument approach aid Critical Areas at all times and ILS / PAR Sensitive Areas during LVP operations. These areas are defined as:

- a. **Critical Area.** An area of defined dimensions extending about the ground antennae of precision instrument approach equipment, within which the presence of vehicles or Air System will cause unacceptable disturbance of the guidance signals.
- b. **Sensitive Area.** An area extending beyond the Critical Area where the parking and / or movement of Air Systems or vehicles will affect the guidance signal to the extent that it may be rendered unacceptable to Air Systems using the signal.

17. **Precision Instrument Approach LVP Operations.** Precision approaches are defined as:

- a. **Cat I Operation.** A precision instrument approach and landing with a decision height not lower than 200 ft and with either a visibility not less than 800 m, or a RVR not less than 550 m.
- b. **Cat II Operation.** A precision instrument approach and landing with a decision height lower than 200 ft but not lower than 100 ft, and a RVR not less than 300 m. See MAA 02.

¹⁰ ▶ Refer to RA 3515 – Permanent Fixed Wing Aerodrome: Lighting.

¹¹ Refer to MAA02: MAA Master Glossary.◀

RA 3275 - Runway Visual Range

Rationale

The availability of accurate up-to-date meteorological information is crucial for the safe conduct of flights. On approach to or departure from an Aerodrome, it is important that pilots are able to determine the likelihood of being able to obtain the required visual references to complete a landing or departure.

Contents

3275(1): Provision of Runway Visual Range / Instrumented Runway Visual Range

3275(2): Provision of Human Observed Runway Visual Range

Regulation 3275(1)

Provision of Runway Visual Range / Instrumented Runway Visual Range

3275(1) Runway Visual Range (RVR) / Instrumented RVR (IRVR) **shall** be provided under specified meteorological conditions.

Acceptable Means of Compliance 3275(1)

Provision of Runway Visual Range / Instrumented Runway Visual Range

RVR

1. RVR **should** be provided to pilots whenever:
 - a. The reported meteorological visibility falls to 1500 m or less.
 - b. The IRVR displays a value equal to or less than 1500 m.
 - c. Shallow fog is being reported or during a period for which it is forecast.
2. RVR observations **should** be repeated at intervals, or when requested, during all stages of an instrument approach and landing and the RVR value passed to the pilot within 30 seconds of each observation.

IRVR

3. IRVR values **should** be passed to pilots at the beginning of each approach and, thereafter, whenever there is a significant change¹ in the RVR until the Air System has landed. The IRVR value **should** also to be passed to the pilot before departure and when the IRVR goes below limits for an Air System to make an approach.
4. Unless a suppressed value is specifically requested by a pilot, the IRVR values transmitted **should** contain only those values that are displayed at full intensity. The value of the touchdown position is always displayed at full intensity and if no other values are at full intensity this is the only value which needs to be passed.
5. The three transmissometers are located one at each end of the Runway adjacent to the touchdown zone and the third near the Runway midpoint area. When available, all three positions **should** to be reported to the pilot, they **should** be passed as three numbers relating to touchdown, mid-point and stop end respectively, eg, **RVR 650 — 500 — 550**. If only two values are passed, they **should** be individually identified, eg, **Touchdown 650 — Stop End 550**.
6. **Transmissometer Unserviceability.** If the touchdown transmissometer fails, the IRVR system can still be used providing the mid-point and stop end transmissometers remain serviceable. In such circumstances the mid-point value **should** be passed to the pilot together with the stop end value. The pilot **should** be informed that the touchdown transmissometer has failed, eg, "**Touchdown RVR not available — Mid-Point 600 — Stop End 400.**"
7. If two transmissometers become unserviceable the IRVR value for the remaining transmissometer, provided that it is not the stop end value, can be used. If the IRVR value for the stop end is the only one available, the system **should** be regarded as unserviceable for that Runway. By changing the direction of use of the

¹ A significant change is defined as a change in value of one increment or more.

**Acceptable
Means of
Compliance
3275(1)**

Runway it may become serviceable again with the single available value representing the touchdown reading.

Conversion of Meteorological Visibility to RVR.

8. Where IRVR is not available or unserviceable controllers **should** revert to Human Observer RVR as defined in RA 3275(2) ▶◀. Where neither IRVR or Human Observed RVR are available controllers **should** derive RVR by converting the reported met visibility in accordance with ▶Table 1◀ at para 16.

9. RVR conversion should not be used for calculating take-off minima, Category II or III minima or when RVR or IRVR is available.

**Guidance
Material
3275(1)**

Provision of Runway Visual Range / Instrumented Runway Visual Range

RVR

10. RVR has evolved to make available a more localised assessment of visual range in relation to a particular Runway when the meteorological report gives a visibility of less than 1500 m.

11. The RVR indicates the range over which the pilot of an Air System on the centreline of a Runway can expect to see the Runway surface markings, the lights delineating the Runway or identifying its centreline. The UK standard for reporting RVR extends from zero to 1500 m.

IRVR

12. With some IRVR equipment, transmissometer readings may only be displayed when the Runway lights are set at an intensity of 10% or more. Settings less than 10% may result in all three readings being replaced by zeros. If, during RVR conditions, a pilot requests a reduced Runway edge light setting of less than 10%, ▶they◀ will be advised that an IRVR reading may not be available at this setting.

13. IRVR gives an automatic and continuous display of RVR values to Air Traffic Control (ATC). Transmissometers are used to measure atmospheric opacity from fixed points alongside a Runway, the number of units in any system being determined by the category of the Instrument Landing System installation and Runway length. In a three transmissometer system the units are linked by an associated data transfer system to a central processor.

14. The processor computes the RVR for each transmissometer position and displays it in digital form to ATC. For Radiotelephony transmission purposes the locations will be known as 'Touchdown', 'Mid-Point' and 'Stop End' and RVR values will relate to these positions.

15. IRVR Indications. There are a number of different IRVR systems, the processors in some systems are programmed to automatically reduce in intensity, or suppress, the display of the mid-point and / or stop-end readings when the values are not operationally significant.

16. IRVR readings extend from 25 m to 1500 m in the following steps:

- a. 0 to 400 m in 25 m steps.
- b. 400 to 800 m in 50 m steps.
- c. 800 to 1500 m in 100 m steps.

▶Table 1. RVR Conversion Table for no IRVR or Human Observed Report◀

| Lighting Elements Available at the Airfield | RVR = Reported Met Visibility Multiplied By: | |
|---|--|-------|
| | Day | Night |
| High Intensity Approach and Runway Lighting | 1.5 | 2.0 |
| Any Type of Lighting other than Above | 1.0 | 1.5 |
| No Lighting Available | 1.0 | N/A |

**Regulation
3275(2)**

Provision of Human Observed Runway Visual Range

3275(2) Where the use of RVR / IRVR equipment is not possible, Aerodromes **shall** provide measurements of human observed RVR.

**Acceptable
Means of
Compliance
3275(2)**

Provision of Human Observed Runway Visual Range

17. Human observed RVR **should** only be undertaken by ►a◄ Suitably Qualified and Experienced Person.

**Guidance
Material
3275(2)**

Provision of Human Observed Runway Visual Range

18. The observer will count the number of RVR installation lights seen and pass this figure to the Aerodrome controller who will convert the reported figure to a distance in metres by reference to the RVR conversion table, and pass this information to the appropriate controller for transmission to the pilot.

19. **Human Observed RVR Conversion Tables.** Human observed RVR conversion tables will be available to Aerodrome controllers at all times. Units will prepare and ensure the accuracy of conversion tables after initial installation and thereafter when:

- a. Doubt exists whether the layout of the RVR system continues to comply with the standard siting plan as detailed in RA 3521(2)².
- b. Doubt exists that the height and position of the observation point continues to comply with specification detailed in the RA 3521(2).

20. Human Observed RVR conversion tables will be created in the following manner:

- a. Obtain the actual distance of each RVR light measured from the observation point (as provided during detailed installation survey).
- b. Round the corrected distances down to the next 50 m increment (up to 800 m) or to the next 100 m increment (beyond 800 m) to obtain the converted RVR.
- c. The RVR Conversion Table consists of the RVR light number and the converted RVR distance in metres (see ►Table 2◄ RVR Conversion Table – Sample Calculations).

►Table 2.◄ RVR Conversion Table – Sample Calculations

| RVR LIGHT No (a) | ACTUAL DISTANCE OF RVR LIGHT (m) (b) | CORRECTION TO BE SUBTRACTED (m) (c) | CORRECTED DISTANCE (m) (b-c) | CONVERTED RVR DISTANCE (m) (d) |
|------------------|--------------------------------------|-------------------------------------|------------------------------|--------------------------------|
| 1 | 210 | 20 | 190 | 150 |
| 2 | 268 | 25 | 243 | 200 |
| 3 | 326 | 25 | 301 | 300 |
| 4 | 385 | 30 | 355 | 350 |
| 5 | 445 | 35 | 410 | 400 |
| 6 | 504 | 40 | 464 | 450 |
| 7 | 564 | 40 | 524 | 500 |
| 8 | 623 | 45 | 578 | 550 |
| 9 | 683 | 45 | 638 | 600 |
| 10 | 743 | 50 | 693 | 650 |
| 11 | 803 | 55 | 748 | 700 |

² RA 3521(2): Runway Visual Range Systems.

**Guidance
Material
3275(2)**

| | | | | |
|----|------|----|------|------|
| 12 | 902 | 55 | 847 | 800 |
| 13 | 1002 | 60 | 942 | 900 |
| 14 | 1102 | 65 | 1037 | 1000 |
| 15 | 1202 | 75 | 1127 | 1100 |
| 16 | 1301 | 85 | 1226 | 1200 |
| 17 | 1401 | 90 | 1311 | 1300 |
| 18 | 1501 | 90 | 1401 | 1400 |

21. Obtain the corrected RVR light distances (b-c) by subtracting the corrections given in ► **Table 2** ◀ – RVR Conversion Table from actual RVR light distance (b).
22. Round down the corrected distances (b-c) to the next lower 50 m increment (up to 800 m) or next lower 100 m increment (beyond 800 m) to obtain the converted RVR distances (d).
23. The final RVR Conversion Table for the Aerodrome used in this example would consist of columns (a) and (d).
24. Column (c) details the corrections that will be applied to RVR light distances to avoid an overestimation of the RVR.

RA 3277 - Wake Turbulence

Rationale

All Aircraft, including ► jet-lift, ◀ rotary wing and tilt-rotor, ► ◀ generate vortices as a consequence of producing lift. The resultant wake turbulence can create hazardous flight conditions for Aircraft operating in close proximity. ► If the prescribed wake turbulence separation minima are not conformed to, there is an increased Risk to Life in an Aviation Duty Holder's (ADH) / Accountable Manager (Military Flying)'s (AM(MF)) operation due to the increased Risk of the pilot inadvertently losing control of the Aircraft. ◀ Controllers and pilots are ► therefore ◀ responsible for ► ensuring that the ◀ appropriate ► wake turbulence separation between Aircraft is observed to reduce the likelihood of encountering ◀ wake turbulence.

Contents

3277(1): Wake Turbulence

Regulation 3277(1)

Wake Turbulence

3277(1) ADH, AM(MF), ADH-Facing Organizations and Heads of Establishment **shall** ensure appropriate wake turbulence separation minima are applied.

Acceptable Means of Compliance 3277(1)

Wake Turbulence

1. Wake turbulence separation minima **should** be based on the UK Civil Aviation Authority (CAA) wake turbulence categories¹, as reproduced in Tables 1 and 2.

Table 1. International Civil Aviation Organization (ICAO) and UK CAA Fixed Wing Aircraft Wake Turbulence Categories¹ (based on Maximum Certificated Take-off Mass (MCTOM))

| Category | ICAO and Flight Plan (kg) | UK Departures (MCTOM kg) | UK Arrivals (MCTOM kg) |
|------------------------------|---------------------------|-----------------------------------|------------------------|
| SUPER² (J) | ≥136,000 | ≥136,000 | ≥136,000 |
| HEAVY (H) | ≥136,000 | ≥136,000 | ≥136,000 |
| MEDIUM (M) | >7,000 and <136,000 | >40,000 and <136,000 ³ | N/A |
| UPPER MEDIUM (UM) | N/A | N/A | >104,000 and <136,000 |
| LOWER MEDIUM (LM) | N/A | N/A | >40,000 and ≤104,000 |
| SMALL (S) | N/A | >17,000 and ≤40,000 | >17,000 and ≤40,000 |
| LIGHT (L) | ≤7,000 | ≤17,000 | ≤17,000 |

Table 2. ICAO and UK CAA Rotary Wing and Tilt-rotor Aircraft Wake Turbulence Categories¹ (based on MCTOM)

| Category | ICAO and Flight Plan (kg) | UK Departures (MCTOM kg) | UK Arrivals (MCTOM kg) |
|------------------------------|---------------------------|-----------------------------------|------------------------|
| MEDIUM (M) | >7,000 and <136,000 | >40,000 and <136,000 ³ | N/A |
| UPPER MEDIUM (UM) | N/A | N/A | >104,000 and <136,000 |
| LOWER MEDIUM (LM) | N/A | N/A | >40,000 and ≤104,000 |
| SMALL⁴ (S) | N/A | ≥7,000 and ≤40,000 | ≥7,000 and ≤40,000 |
| LIGHT⁴ (L) | ≤7,000 | <7,000 | <7,000 |

2. **Flight Plan.** The wake turbulence category of an Aircraft **should** be indicated on the Flight Plan (ICAO Flight Plan Item 9) as J, H, M or L according to the ICAO

¹ Refer to Civil Aviation Publication (CAP) 493 – Manual of Air Traffic Services (MATS) Part 1, Annex B.

² The SUPER category is only assigned to specific Aircraft types; A380-800, AN-124 Ruslan and AN-225 Mriya.

³ The MEDIUM category is not split into UPPER MEDIUM and LOWER MEDIUM for the purposes of wake turbulence separation on departure.

⁴ In the UK, the CAA has stipulated that all rotary wing Aircraft and tilt-rotor Aircraft with a MCTOM greater than or equal to 7,000 kg and less than or equal to 40,000 kg are to be classified as SMALL for the purposes of providing wake turbulence separation.

**Acceptable
Means of
Compliance
3277(1)**

specifications, not the UK category. The categories UM, LM and S are UK categories only and **should not** be entered onto the Flight Plan.

3. **Radiotelephony (RTF)**⁵. Aircraft in the SUPER or HEAVY wake turbulence category **should** include the word 'Super' or 'Heavy' immediately after the Aircraft callsign in the initial call to each Air Traffic Service (ATS) Unit.
4. Wake turbulence separation **should** be based upon flight rules, not the type of ATS applied.
5. **▶ Wake turbulence separation **should** be applied to consecutive arrivals and to consecutive departures.**
6. **By providing the appropriate wake turbulence separation to an Aircraft inbound for a touch and go or low approach, the Aircraft **should** be considered as having adequate wake turbulence separation for its climbout. The wake turbulence separation minima for Aircraft conducting a touch and go or low approach immediately before or after a Runway departure is detailed in paragraphs 13 and 14 for Instrument Flight Rules (IFR) Aircraft and 18 and 19 for Visual Flight Rules (VFR) Aircraft.**
7. **To aid the sequencing of Aircraft, Air Traffic Control (ATC) can request an Aircraft to take off without delay⁶. If the pilot is unable to conform they **should** advise ATC immediately.**
8. **Maritime Operations.** Wake turbulence separation **should not** be applied when aviation capable Ships⁷ are underway.

IFR ◀

9. **▶ ◀ General Conditions.** Aircraft requesting an IFR approach or departure **should** be subject to IFR wake turbulence separation. Where the separation minima required for IFR flights are greater than the wake turbulence separation minima, the IFR separation minima **should** be applied.
10. **▶ ◀ Approaches.** The wake turbulence separation minima in Table 3 **should** be applied to IFR Aircraft in the intermediate and Final Approach⁸ phases of flight^{9, 10} when:
 - a. An Aircraft is operating directly behind another Aircraft at the same Altitude or less than 1000 ft below; or
 - b. An Aircraft is crossing behind another Aircraft, at the same Altitude or less than 1000 ft below; or
 - c. Both Aircraft are using the same Runway or parallel Runways separated by less than 760 m¹¹.

⁵ Refer to CAP 413 – Radiotelephony Manual, Chapter 2.

⁶ **▶ Refer to CAP 413 – Radiotelephony Manual, Chapter 4.**

⁷ **Aviation capable Ships are defined as those which can be categorized as Applicability Level A, B or C in Defence Standard 00-133. ◀**

⁸ Refer to CAP 1430 – UK Air Traffic Management Vocabulary for the definition of intermediate approach segment and Final Approach.

⁹ MOD wake turbulence Regulations combine the intermediate approach segment and Final Approach phases to provide one set of approach criteria.

¹⁰ For military IFR approaches not depicted on a terminal approach chart, such as a radar straight-in approach, wake turbulence separation standards **should** be applied once the Aircraft is established on the procedure and within 10 nm of the Aerodrome.

¹¹ Refer to CAP 493 – MATS Part 1, Section 1, Chapter 3.

**Acceptable
Means of
Compliance
3277(1)**

Table 3. Wake Turbulence Separation Minima for the Final Approach Phase of Flight¹¹

| Leading Aircraft | Following Aircraft | Wake Turbulence Separation Minimum Distance (nm) ¹² |
|------------------|------------------------|--|
| SUPER | SUPER | # |
| | HEAVY | 5 |
| | UPPER and LOWER MEDIUM | 7 |
| | SMALL | 7 |
| | LIGHT | 8 |
| HEAVY | SUPER | # |
| | HEAVY | 4 |
| | UPPER and LOWER MEDIUM | 5 |
| | SMALL | 6 |
| | LIGHT | 7 |
| UPPER MEDIUM | SUPER | # |
| | HEAVY | # |
| | UPPER MEDIUM | 3 |
| | LOWER MEDIUM | 4 |
| | SMALL | 4 |
| LOWER MEDIUM | LIGHT | 6 |
| | SUPER | # |
| | HEAVY | # |
| | UPPER MEDIUM | # |
| | LOWER MEDIUM | # |
| SMALL | SMALL | 3 |
| | LIGHT | 4 |
| | SUPER | # |
| | HEAVY | # |
| | UPPER MEDIUM | # |
| LIGHT | LOWER MEDIUM | # |
| | SMALL | # |
| | LIGHT | # |
| | SUPER | # |
| | HEAVY | # |

11. ►◄ **Departures.** The wake turbulence separation minima in Table 4 **should** be applied¹³ to Aircraft departing IFR when operating from:

- a. The same Runway; or
- b. Parallel Runways separated by less than 760 m; or
- c. Parallel Runways separated by 760 m or more, if the projected flight path of the second Aircraft will cross the projected flight path of the first Aircraft at the same Altitude or less than 1000 ft below; or
- d. Crossing Runways if the projected flight path of the second Aircraft will cross the projected flight path of the first Aircraft at the same Altitude or less than 1000 ft below¹¹.

12. ► If the lead Aircraft departs from an intermediate point¹⁴ and the following Aircraft uses a greater Runway distance, the 'Departing from the Same Position' section of the table **should** be applied.

¹² # signifies that separation for wake turbulence reasons alone is not necessary.

¹³ Controllers **should** apply the prescribed minima irrespective of any pilot request for reduced wake turbulence separation.

¹⁴ An intermediate point is any position on the Runway other than the departure threshold.

Acceptable Means of Compliance 3277(1)

13. **Runway departure after a Touch and Go or Low Approach.** Aircraft departing IFR after a preceding Aircraft has conducted a touch and go **should** be provided wake turbulence separation in accordance with (iaw) the top half of Table 4. Due to the wake turbulence characteristics of a low approach, Aircraft departing IFR after a preceding Aircraft that has conducted a low approach **should** be provided wake turbulence separation iaw the lower half of Table 4.

14. **Aircraft conducting a Touch and Go or Low Approach after a Runway departure.** An IFR Aircraft conducting a touch and go or low approach immediately after a Runway departure **should** be provided wake turbulence separation from the preceding Aircraft iaw Table 3. ◀

Table 4. Wake Turbulence Separation Minima for the Departure Phase of Flight¹¹

| Leading Aircraft | Following Aircraft | Minimum Wake Turbulence Separation at the Time Aircraft are Airborne ¹² | |
|--|---------------------------------------|---|---------------------------------------|
| SUPER | SUPER | Departing from the same position or From a parallel Runway separated by less than 760 m | # |
| | HEAVY | | 2 minutes |
| | MEDIUM ³ SMALL LIGHT | | 3 minutes |
| HEAVY | HEAVY | | 4 nm or time equivalent ¹⁵ |
| | MEDIUM SMALL LIGHT | | 2 minutes |
| MEDIUM or SMALL | LIGHT | | |
| ▶ Leading Aircraft | Following Aircraft | Minimum Wake Turbulence Separation at the Time Aircraft are Airborne ¹² ◀ | |
| SUPER (Full length take-off) | SUPER | Departing from an intermediate point ¹⁴ on the same Runway or From an intermediate point ¹⁴ of a parallel Runway separated by less than 760 m | # |
| | HEAVY | | 3 minutes |
| | MEDIUM SMALL LIGHT | | 4 minutes |
| HEAVY (Full length take-off) | HEAVY | | 4 nm or time equivalent ¹⁵ |
| | MEDIUM SMALL LIGHT | | 3 minutes |
| MEDIUM or SMALL (Full length take-off) | LIGHT | | |

▶ **VFR**

15. **General Conditions.** When a flight is operating visually (VFR, IFR making a visual approach or IFR / Special VFR operating under reduced separation in the vicinity of Aerodromes) and is following or crossing behind another Aircraft, Responsibility for wake turbulence separation **should** rest with the pilot. ◀

16. ▶ ◀ **Approaches.** When ▶ a VFR ◀ Aircraft ▶ conducts an approach to the Runway, ◀ and it appears that the separation minimum distance in Table 3 is unlikely to exist ▶ from a preceding arrival ◀, Controllers **should** advise the pilot 'Caution, wake

¹⁵ ICAO PANS-ATM does not require time based wake turbulence separation between departing HEAVY Aircraft. However, it does require distance-based wake turbulence separation. In the UK, a time equivalent can be used if the period of time it takes for an Aircraft to reach 4 nm has been established.

**Acceptable
Means of
Compliance
3277(1)**

turbulence the recommended distance is (number) miles¹⁶. ► If the Aircraft is conducting approaches from the visual circuit, the pilot **should** only be advised 'Caution wake turbulence', however units are not prevented from providing a recommended distance if deemed necessary. ◀

17. ►◀ **Departures**. The wake turbulence separation minima in Table 4 **should** be applied¹³ to Aircraft departing VFR when operating from:

- a. The same Runway; or
- b. Parallel Runways separated by less than 760 m; or
- c. Parallel Runways separated by 760 m or more, if the projected flight path of the second Aircraft will cross the projected flight path of the first Aircraft at the same Altitude or less than 1000 ft below; or
- d. Crossing Runways if the projected flight path of the second Aircraft will cross the projected flight path of the first Aircraft at the same Altitude or less than 1000 ft below¹¹.

18. ► **Runway departure after a Touch and Go or Low Approach**. Aircraft departing VFR after a preceding Aircraft has conducted a touch and go, **should** be provided wake turbulence separation iaw the top half of Table 4. Due to the wake turbulence characteristics of a low approach, Aircraft departing VFR after a preceding Aircraft that has conducted a low approach **should** be provided wake turbulence separation iaw the lower half of Table 4.

19. **Aircraft conducting a Touch and Go or Low Approach after a Runway departure**. When a VFR Aircraft is conducting a touch and go or low approach immediately after a Runway departure, and it appears that the separation minimum distance iaw Table 3 is unlikely to exist, Controllers **should** advise the pilot 'Caution, wake turbulence the recommended distance is (number) miles'. If the Aircraft is conducting a touch and go or low approach from the visual circuit, the pilot **should** only be advised 'Caution wake turbulence' however units are not prevented from providing a recommended distance if deemed necessary.

20. If a unit requires to reduce RTF, caution transmissions to VFR Aircraft can be omitted between Aircraft of the same wake turbulence category but prior to implementing, the unit **should** promulgate the caution and intent to omit the transmissions in the Military Aeronautical Information Publication and Defence Aerodrome Manual.

Formations ◀

21. ►◀ Aircraft employing Formation Flying techniques (close or streamed formation including radar trails) **should not** be provided with wake turbulence separation or warnings against other elements of the formation, unless requested.

► **Rotary Wing and Tilt-rotor Aircraft** ◀

22. ►◀ When a rotary wing or tilt-rotor Aircraft¹¹ Air Taxies across a Runway, wake turbulence separation **should** be applied as if the crossing point was a departure from that intermediate point of the Runway.

23. To minimize the effects of wake turbulence caused by rotary wing or tilt-rotor Aircraft, Controllers:

- a. **Should** instruct rotary wing or tilt-rotor Aircraft to ground taxi, when capable, rather than Air Taxi when operating in areas where Aircraft are parked or holding.
- b. **Should not** allow rotary wing or tilt-rotor Aircraft to Air Taxi close to taxiways or Runways where light Aircraft operations (including light rotary wing operations) are in progress. If Air Taxiing is imperative, the Aircraft **should** be routed to:

- (1) Avoid over flying parked Aircraft, vehicles or ground equipment.

¹⁶ Refer to CAP 413 – Radiotelephony Manual, Chapter 9.

**Acceptable
Means of
Compliance
3277(1)**

(2) Follow standard taxi routes where rotary and fixed wing Aircraft share common areas on a Movement Area.

24. When a rotary wing or tilt-rotor Aircraft is Air Taxiing or hovering¹⁷, Controllers and pilots **should** avoid taxiing light Aircraft (including light rotary wing and tilt-rotor Aircraft) within a minimum area comprising three times the rotor diameter of that rotary wing or tilt-rotor Aircraft, see Annex B. Controllers and pilots **should** consider this to be a minimum distance which will need to be increased for larger rotary wing or tilt-rotor Aircraft.

25. Controllers **should** exercise caution when an Aircraft of a lower wake turbulence category is cleared to land on a Runway immediately after a rotary wing or tilt-rotor Aircraft of higher wake turbulence category has landed or taken-off from that Runway's threshold.

**Guidance
Material
3277(1)**

Wake Turbulence

26. **Wake Turbulence Characteristics**¹⁸. All Aircraft, including rotary wing and tilt-rotor Aircraft, generate vortices as a consequence of producing lift. The heavier the Aircraft and the more slowly it is flying, the stronger the vortex. Vortices are especially persistent in calm conditions. They are most hazardous to Aircraft with a small wingspan during the take-off, initial climb, final approach, and landing phases of flight.

27. A vortex Hazard may exist for about two minutes along a Runway after a large Aircraft has executed a low approach or a touch and go.

28. **Fixed Wing Aircraft.** Wake vortices begin to be generated by fixed wing Aircraft when the nose wheel lifts off the Runway on take-off and continue until the nose wheel touches down on landing.

29. **Rotary Wing Aircraft.** When rotary wing Aircraft mass is transferred from the landing gear to the rotor a strong downwash is created in all directions. When rotary wing Aircraft are in forward flight the downwash from the main rotor(s) is transformed into a pair of trailing vortices, similar to the wing tip vortices of a fixed wing Aircraft. There is some evidence that, per kilogram of gross mass, the wake turbulence generated by a rotary wing Aircraft is more intense than that of a fixed wing Aircraft.

30. **Tilt-rotor Aircraft.** Tilt-rotor Aircraft combine the characteristics of fixed wing and rotary wing Aircraft. For vertical flight, the rotors are angled so the plane of rotation is horizontal, lifting the Aircraft in the way of a rotary wing Aircraft. As the Aircraft's indicated airspeed increases, the rotors are progressively tilted forward, with the plane of rotation eventually becoming vertical, with the fixed wings providing lift and the rotors providing thrust. On final approach, as the Aircraft reduces speed, the rotors are progressively tilted backward. As such, tilt-rotor Aircraft operate as rotary wing Aircraft on final approach and departure, and as fixed wing Aircraft in the en-route and intermediate approach phases.

31. **▶ Jet-lift Aircraft.** The downwash produced by jet-lift Aircraft, such as the F-35B differs from that of other fixed wing and rotary wing Aircraft. Typically both fixed wing and rotary wing Aircraft produce a circular downwash pattern that is fairly symmetrical in shape, whereas a jet-lift Aircraft produces a more irregular shape that can produce 'spikes'. These spikes are caused by several separate flow patterns interacting with one another which causes a greater velocity than the average downwash or outwash experienced by other Aircraft types. Research on the full impact of wake vortices and downwash produced by jet-lift Aircraft is ongoing and there is currently no defined criteria for the wake turbulence separation to be applied, particularly when carrying out profiles such as slow approaches or Short Take-Off and Vertical Landing (STOVL). Therefore, local orders at relevant Aerodromes will need to stipulate the wake turbulence mitigations required against other Aircraft when a jet-lift Aircraft is arriving, departing or operating in the visual circuit. ◀

32. **General.** Wake turbulence separation minima is the spacing, determined either by time or distance, to be applied so that Aircraft do not fly through the wake of a preceding Aircraft within the area of maximum vortices. Under most circumstances,

¹⁷ Including hovering operations such as underslung loads, sloping ground etc.

¹⁸ Refer to Aeronautical Information Circular P 083/2020 – Wake Turbulence.

**Guidance
Material
3277(1)**

normal separation minima (Runway occupancy rules and departure releases) will provide adequate wake turbulence separation.

33. The wake turbulence categories of frequently controlled Military Aircraft can be found in Annex A. In addition, a database containing the UK wake turbulence categories of the Aircraft types most commonly provided with ATS in the UK can be found in CAP 493, Annex B¹.

34. **IFR Departures.** Wake turbulence separation minima on departure will be applied by measuring airborne times or distances between successive Aircraft, see Table 4. Take-off clearance may be issued with an allowance for the anticipated take-off run on the Runway; however, the airborne time interval will reflect a difference of at least the required time separation.

35. 

Civil Equivalence

36. This Regulation is in line with CAP 493 – MATS Part 1.

ANNEX A

UK Wake Turbulence Categories for Common Military Aircraft Types

| HEAVY Fixed Wing Aircraft MCTOM \geq136,000 kg | UPPER MEDIUM Fixed Wing Aircraft MCTOM >104,000 kg and <136,000 kg |
|---|---|
| Atlas A400M C5 Galaxy C17 Globemaster Rivet Joint Voyager | Nil |
| LOWER MEDIUM Fixed Wing Aircraft MCTOM >40,000 kg and \leq104,000 kg | SMALL Fixed Wing Aircraft MCTOM >17,000 kg and \leq40,000 kg |
| C130J Hercules P-8 Poseidon E-7 Wedgetail | Envoy Typhoon F-35 Lightning II F15E Lancaster |
| LIGHT Fixed Wing Aircraft MCTOM \leq17,000 kg | |
| Hawk Shadow Avenger Tutor Reaper Protector Watchkeeper Dakota Spitfire | Hurricane Chipmunk Phenom Prefect Texan Vigilant |
| SMALL Rotary Wing Aircraft¹⁹ MCTOM \geq7,000 kg and \leq40,000 kg | LIGHT Rotary Wing Aircraft MCTOM <7,000 kg |
| Apache Chinook CH53 CV-22B MV-22B Merlin Puma | AW109SP Griffin Bell 212 Wildcat Gazelle Juno Jupiter Dauphin |

¹⁹ **Note:** Rotary wing Aircraft such as Puma or larger are classified as SMALL due to their wake turbulence characteristics, rather than LIGHT iaw their MCTOM.

ANNEX B

Rotor Diameters for Common Military Rotary Wing Aircraft Types

| SMALL Rotary Wing Aircraft¹⁹ | Rotor Diameter (rounded up) |
|--|------------------------------------|
| Apache | 50 ft |
| Chinook | 60 ft |
| CH53 | 80 ft |
| CV-22B | 85 ft |
| MV-22B | 85 ft |
| Merlin | 65 ft |
| Puma | 55 ft |
| LIGHT Rotary Wing Aircraft | Rotor Diameter (rounded up) |
| AW109SP | 40 ft |
| Griffin | 50 ft |
| Bell 212 | 50 ft |
| Wildcat | 45 ft |
| Gazelle | 35 ft |
| Juno | 35 ft |
| Jupiter | 40 ft |
| Dauphin | 40 ft |

Intentionally Blank for Print Pagination

► This RA has been substantially re-written; for clarity no change marks are presented – please read the RA in its entirety ◀

RA 3278 – Snow and Ice Operations

Rationale

During operations in adverse winter conditions, the presence of snow, slush, ice and other similar contaminants can significantly degrade the visual references and friction performance of Aerodrome surfaces. Without appropriate management of such contaminants, Aerodrome surfaces may become unsafe and unavailable for use. Appropriate planning for and response to adverse winter conditions will ensure that Aerodromes continue to meet functional requirements and ensure that a Safe Operating Environment is maintained and disruption to operations are minimized.

Contents

3278(1): Snow and Ice Operations

3278(2): Withdrawn – Incorporated into RA 3278(1)

Regulation 3278(1)

Snow and Ice Operations

3278(1) When the Aerodrome is available for use during adverse winter conditions, the Head of Establishment (HoE) **shall** ensure that contaminants on the Movement Area are adequately managed to enable the safe operation of Aircraft at all times.

Acceptable Means of Compliance 3278(1)

Snow and Ice Operations

1. An Aerodrome Snow and Ice Control Plan **should** be developed and implemented in accordance with (iaw) AP119J-0100-1¹, detailing the priority order of and extent to which surfaces are to be cleared of contaminants.
2. The Aerodrome Snow and Ice Control Plan **should** be reviewed annually.
3. Contaminants, such as snow, slush and ice, **should** be removed from the surface of Runways in use and other Movement Areas, iaw Aerodrome requirements, as rapidly and completely as possible to minimize accumulation.
4. The friction of the area treated **should** be measured periodically after the contaminants are removed, iaw RA 3272(1)².
5. The evaluation and reporting of Runway surface conditions **should** be carried out iaw RA 3272(2)³.
6. The use of chemicals to remove or to prevent or disperse the formation of ice and frost on Aerodrome pavements **should** be carried out iaw AP119J-0100-1 and subject to environmental management iaw RA 1800⁴.

Guidance Material 3278(1)

Snow and Ice Operations

7. The prioritisation policy for the allocation of fleet-managed assets to support snow and ice control operations is contained in AP119J-0100-1.
8. AP119J-0100-1 contains detailed guidance on the planning, operations and reporting requirements for snow and ice control, and the types of chemicals currently approved for use on MOD Aerodromes.

¹ Refer to AP119J-0100-1 – Snow Clearance and Ice Control of Airfields.

² Refer to RA 3272(1): Continuous Friction Monitoring Equipment.

³ Refer to RA 3272(2): Reporting of Runway Surface Conditions.

⁴ Refer to RA 1800 – Aerodrome and Air Weapon Range Aviation Activity - Management of Environmental Impacts and Risks.

**Guidance
Material
3278(1)**

9. Further guidance on the control and removal of contaminants is contained in International Civil Aviation Organization (ICAO) Doc 9137⁵ and Civil Air Publication (CAP) 168, Appendix 3G⁶.

10. 'Op BLACKTOP' is the term commonly used to describe activation of the Aerodrome Snow and Ice Control Plan. For the UK, this typically occurs between 1 November to 30 April when winter conditions are most likely to be present, however, this may vary each year depending on the forecast meteorological conditions. The Aerodrome Operator is usually responsible for deciding if Op BLACKTOP is required to start early or finish later than these dates.

11. Establishments are advised to review the Aerodrome Snow and Ice Control Plan following the winter period, to assess effectiveness and any areas for improvement.

12. Runways affected by compacted snow and ice are not normally available for use, but this RA does not prohibit operations taking place where it is deemed operationally essential and safe to do so.

Civil Equivalence

13. This Regulation is in line with ICAO Annex 14 Vol I ninth edition, para 10.3.1 – 10.3.6.

**Regulation
3278(2)**

Aerodrome Snow and Ice Plan

3278(2) Withdrawn – Incorporated into RA 3278(1).

**Acceptable
Means of
Compliance
3278(2)**

Aerodrome Snow and Ice Plan

14. Withdrawn – Incorporated into RA 3278(1).

**Guidance
Material**

Aerodrome Snow and Ice Plan

15. Withdrawn – Incorporated into RA 3278(1).

⁵ Refer to ICAO Doc 9137 – Airport Services Manual, Part 2.

⁶ Refer to CAP 168 – Licensing of Aerodromes, Appendix 3G: Care of pavements during winter conditions – improving Surface friction by removal of contaminants.

RA 3279 – Aircraft Last Look Checks

Rationale

At some Aerodromes, Aircraft Last Look Checks (ALLC) are required to assist in the safe operation of Aircraft in the vicinity of the Aerodrome. As an important Air Safety barrier, if ALLC are unavailable, there may be an increased Risk to Life (RtL) in an Aviation Duty Holder (ADH) / Accountable Manager (Military Flying) (AM(MF)) operation. At those Aerodromes that require them, the equipment provision, installation, and associated operating procedures of ALLC will enhance the safe operation of Aircraft using, or about to use, the Manoeuvring Area.

Contents

Definitions Relevant to this RA

3279(1): Requirement for Aircraft Last Look Checks

3279(2): Establishment of Aircraft Last Look Checks

3279(3): Provision of Aircraft Last Look Checks

3279(4): Equipment and Operating Requirements – Truck Runway Control

3279(5): Equipment and Operating Requirements – Digital Aircraft Last Look Checks

Definitions

Definitions Relevant to this RA

1. **Aircraft Last Look Checks.** A dedicated role / task to supplement the provision of an Aerodrome Service¹ by providing additional Safety checks for Aircraft using, or about to use, the Manoeuvring Area.

Regulation 3279(1)

Requirement for Aircraft Last Look Checks

- 3279(1) ADHs / AM(MF)s **shall** determine the requirement for ALLC, for their platforms.

Acceptable Means of Compliance 3279(1)

Requirement for Aircraft Last Look Checks

2. ADHs / AM(MF)s **should** utilize extant Safety Management processes to determine the requirement for ALLC in accordance with (iaw) RA 1200².

Guidance Material 3279(1)

Requirement for Aircraft Last Look Checks

3. Nil.

Regulation 3279(2)

Establishment of Aircraft Last Look Checks

- 3279(2) ADH-Facing Organizations and AM(MF)-Facing Organizations (AA-Facing Organizations)³, in consultation with ADHs / AM(MF)s, **shall** determine the Aerodromes at which ALLC are to be provided.

¹ Refer to RA 3261 – Aerodrome Service.

² Refer to RA 1200 – Air Safety Management.

³ Refer to RA 1032 - Aviation Duty Holder-Facing Organizations and Accountable Manager (Military Flying)-Facing Organizations - Roles and Responsibilities. Throughout this RA, the term AA-Facing Organizations refers to Internal AA-Facing Organizations iaw RA 1032(1).

**Acceptable
Means of
Compliance
3279(2)**

Establishment of Aircraft Last Look Checks

4. AA-Facing Organizations **should** consult with the relevant ADHs / AM(MF)s and utilize extant Safety Management processes, iaw RA 1200², to determine:
 - a. Aerodromes that require the provision of ALLC.
 - b. The most suitable capability solution to enable ALLC.
5. AA-Facing Organizations **should** consult with relevant Front Line Commands (FLCs) and Heads of Establishment (HoE) to implement and maintain the provision of ALLC.

**Guidance
Material
3279(2)**

Establishment of Aircraft Last Look Checks

6. ALLC may be provided by a variety of methods. Historically, a staffed 'Truck Runway Control (TRC)', positioned adjacent to the threshold of the Runway in use, has been the default solution. However, digital capabilities are now available using remotely controlled cameras and signalling systems, connected to an operator work position.

**Regulation
3279(3)**

Provision of Aircraft Last Look Checks

- 3279(3) AA-Facing Organizations **shall** ensure that ALLC are effective.

**Acceptable
Means of
Compliance
3279(3)**

Provision of Aircraft Last Look Checks

7. AA-Facing Organizations **should** ensure that a Suitably Qualified and Experienced Person conducts ALLC checks.
8. **Availability.** An ALLC Operator **should** be available at their designated work position whenever known Aircraft movements are taking place, except:
 - a. At the discretion of the Aerodrome Controller (ADC)
 - (1) when instrument approaches are taking place in visibility conditions that preclude a reliable ALLC.
 - (2) the ALLC work position need not be staffed when the time interval between known Aircraft movements permits, provided that an ALLC Operator is immediately available to return to their work position when required.
 - b. At Military Emergency Diversion Aerodromes (MEDA), where Air Traffic Control (ATC) is staffed solely to meet MEDA commitments.
 - c. When detailed by the Aerodrome Operator (AO) and promulgated in Local / Unit Orders iaw RA 1026⁴.
9. **Immediate Actions.** If the ALLC Operator determines that there is a Hazard present, in the air or on the ground, they **should** refuse the Aircraft permission to:
 - a. Make an approach to the Runway.
 - b. Move from the Runway Holding Point.
 - c. Take-off.
10. The type of intervention the ALLC Operator chooses to make will depend upon the urgency of the situation and time available, therefore the ALLC Operator **should** be proficient in the following:
 - a. Direct use of Radio Telephony (RT) Phraseology, to Aircraft and / or vehicles, iaw CAP 413⁵.
 - b. Use of light and / or pyrotechnic signals by day and night as detailed in RA 3261¹.

⁴ Refer to RA 1026 – Aerodrome Operator and Aerodrome Supervisor (Recreational Flying) Roles and Responsibilities.

⁵ Refer to CAP 413 – Radio Telephony Manual.

**Acceptable
Means of
Compliance
3279(3)**

- c. Verbal communication by any means to the ADC and / or Ground Controller.
11. **Reporting.** The ALLC Operator **should** report to the ADC, with the least possible delay, incidents of the following nature:
- Non-standard or unusual signals from Aircraft.
 - Unusual appearance or movement of Aircraft.
 - Visual defects on an Aircraft⁶.
 - Any other situation or occurrence that they feel could affect the Safety of an Aircraft, vehicle, or person.
12. **Checking of Equipment.** The ALLC Operator **should** check all their equipment prior to the start of flying and report any defects or unserviceability to the watch supervisor and, once flying has commenced, report any equipment issues without delay.
13. **Night Flying – Additional Responsibilities.** During night flying, subject to their field of vision, the ALLC Operator **should** report, to the ADC, any failures of:
- Aircraft navigation lights or identification lights.
 - Aerodrome Ground Lighting.
14. **Log Keeping.** The ALLC Operator **should** maintain a log to record unusual occurrences, action taken and any other pertinent information iaw RA 3204⁷ and Single Service policy. Completing log entries **should not** distract from the efficient execution of their duties.
15. Where ALLC are provided, this **should** be annotated in the Unit Defence Aerodrome Manual (DAM) and Military Aeronautical Information Publication (Mil AIP) and include, as a minimum:
- The signalling capabilities available.
 - Where signals will be presented from.
 - Minimum visibility conditions for provision of ALLC.

**Guidance
Material
3279(3)**

Provision of Aircraft Last Look Checks

16. The following list, although not exhaustive, highlights situations in which the ALLC Operator may take action:
- The ALLC Operator may, where appropriate, refuse Aircraft permission to make an approach to the Runway in the following circumstances:
 - Aircraft appears in an incorrect configuration, or the landing gear does not appear fully down.
 - If there is a danger of collision.
 - If the path of the approaching Aircraft is obstructed.
 - If clearance to do so has not been given.
 - On instruction from the ADC.
 - The ALLC Operator may, where appropriate, refuse permission for Aircraft to move from the holding position in the following circumstances:
 - If to do so would obstruct an Aircraft approaching to land or about to take-off.
 - If clearance to do so has not been given.
 - On instruction from the ADC.

⁶ Refer to AP 3457 – Air Traffic Control Last Look Checks.

⁷ Refer to RA 3204 – Air Traffic Management Records.

**Guidance
Material
3279(3)**

c. The ALLC Operator may, where appropriate, refuse Aircraft permission to take-off in the following circumstances:

- (1) If to do so might obstruct an Aircraft making an approach or about to take-off (for example, where more than one Runway is in use).
- (2) When an Aircraft defect is noticed.
- (3) If clearance to do so has not been given.
- (4) On instruction from the ADC.

17. The monitoring of other Airfield activity⁸ that is not associated with the primary task of providing ALLC will be annotated in local orders and based on Single Service policy where applicable.

18. Where a TRC is employed, visibility of less than 800 m is the recommended limit for allowing the ALLC Operator to be withdrawn from their work position. Where a digital ALLC capability is employed, visibility of less than 800 m may be considered as a default value for allowing the ALLC operator to be withdrawn from their work position, however this value may be adjusted, subject to the performance of the digital system and a local Safety Assessment.

19. An Aircraft Movements Log, as required under RA 3204⁹, may be maintained by the ALLC Operator where it is judged that this will not be a distraction to their primary role. If it is deemed to be a distraction, units will make other arrangements for the Aircraft Movements Log to be maintained.

20. If unserviceability or non-availability of equipment occurs, the watch supervisor will determine whether the provision of ALLC can continue fully, partially, or needs to be withdrawn, and liaise accordingly with the relevant Aerodrome users.

**Regulation
3279(4)**

Equipment and Operating Requirements – Truck Runway Control

3279(4) HoEs and AA-Facing Organizations **shall** ensure that the TRC, when employed for ALLC duties, meets minimum equipment specifications and operating requirements.

**Acceptable
Means of
Compliance
3279(4)**

Equipment and Operating Requirements – Truck Runway Control

21. **Vehicle type and markings.** The TRC **should**:

- a. Be of a suitable size and ergonomic design to enable the ALLC Operator to discharge their duties.
- b. Include suitable lookout ports or cupola to enable a sufficient view of the Runway in use, its approaches, holding positions and adjacent taxiways.
- c. Be marked and lit iaw RA 3267¹⁰ and include a red obstruction light at the highest point of the TRC.

22. **Position.** The TRC **should** be positioned as follows:

- a. **On Runway Aerodromes.** To the left or right of the Runway, a minimum of 45 m (150 ft) from the Runway edge and 70 m (225 ft) from the threshold.
- b. **On Non-Runway Aerodromes.** At the down-wind side of the Aerodrome, and so positioned that 2 or more Aircraft may land simultaneously to the right of the truck with sufficient space available to the left of the truck to enable Aircraft to take-off.
- c. When not in use for the provision, or planned provision, of ALLC, the TRC **should** be removed from its operating position if to leave it in place would present a Hazard to Aircraft.

23. **Equipment.** The TRC **should**, as a minimum, be equipped with:

- a. Mains electric power.

⁸ This may include but is not limited to wildlife activity, driving routes, foreign object debris and work in progress.

⁹ Refer to RA 3204 – Air Traffic Management (ATM) Records.

¹⁰ Refer to RA 3267 – Aerodrome Vehicle Marking and Lighting Requirements.

**Acceptable
Means of
Compliance
3279(4)**

- b. Normal internal electric lighting.
- c. **Signalling:**
 - (1) Red, green and white light signals.
 - (2) Two pyrotechnic pistols with sufficient ammunition, with integrated firing ports where required.
 - (3) At least two serviceable means of signalling available, to provide resilience if one fails.
- d. **Communications:**
 - (1) RT monitoring and transmission capability.
 - (2) Telephone.
 - (3) Direct line communications with ATC.
- e. **Miscellaneous Equipment:**
 - (1) TRC wind direction indicator.
 - (2) Binoculars.
 - (3) Clock (synchronized with clock in ATC).
 - (4) Plan of Aerodrome, with crash map.
 - (5) Logbooks (maintained iaw RA 3204⁷).
 - (6) Secure pyrotechnic box.
 - (7) Fire extinguisher.
 - (8) Torch.

**Guidance
Material
3279(4)**

Equipment and Operating Requirements – Truck Runway Control

24. Whilst the TRC is considered an operationally essential obstruction iaw with RA 3590(12)¹¹, this will only apply when it is in position for the purpose of providing ALLC, including temporary periods when it is not in use due to the ALLC operator being withdrawn iaw with para 6.

25. However, when the ALLC operator is withdrawn due to poor visibility conditions, which are unlikely to improve during the period of planned flying or MEDA commitment, the Watch Supervisor will consider removing the TRC from its operating position.

**Regulation
3279(5)**

Equipment and Operating Requirements – Digital Aircraft Last Look Checks

3279(5) HoE and AA-Facing Organizations **shall** ensure that when employing Digital ALLC equipment, it meets minimum specifications and operating requirements.

**Acceptable
Means of
Compliance
3279(5)**

Equipment and Operating Requirements – Digital Aircraft Last Look Checks

26. **Equipment.** The following minimum equipment parameters **should** be met:
- a. Remote Pan-Tilt-Zoom (PTZ) cameras positioned to ensure that a sufficient view of the Runway in use, its approaches, holding positions and adjacent taxiways can be transmitted to the Operator Work Position (OWP).
 - b. Remote light signals capable of red, green and white signals, positioned so that the signals they provide can be seen by the intended recipient from the Runway in use, its approaches, holding positions and adjacent taxiways.

¹¹ Refer to RA 3590(12): Safeguarding – Operationally Essential Operations.

**Acceptable
Means of
Compliance
3279(5)**

- c. Remote PTZ cameras and light signals positioned so as to present the lowest practicable obstruction iaw RA 3512¹² and RA 3590¹³, whilst being able to perform their function.
- d. The position of remote light signals added to the Mil AIP, DAM and local orders.
- e. The OWP located to enable optimal communication and liaison with the ADC.

27. **Operation.** Digital ALLC procedures **should** be iaw the ALLC User Manual and defined in local orders including, as a minimum:

- a. Daily routine for set-up procedures and equipment checks.
- b. Action in the event of loss of visual surveillance or signalling capability.
- c. Remote camera operating procedures.
- d. Remote light signal operating procedures.

**Guidance
Material
3279(5)**

Equipment and Operating Requirements – Digital Aircraft Last Look Checks

28. Location of Remote PTZ and light signals.
- a. Remote PTZ cameras and light signal installations will be considered as operationally essential obstructions iaw RA 3590¹³.
 - b. If Remote light signals are only located adjacent to main / instrument Runways, local procedures will be required to cater for the provision of signals to other Runways (including simultaneous Runway ops).
29. Operation of Remote light signals.
- a. If the remote light signal equipment becomes unserviceable, handheld light signals may provide a fallback signalling capability.
 - b. The routine use of handheld light signals from the Visual Control Room (VCR), iaw RA 3261¹, is unaffected. However, where both handheld and remote light signals are available, care will be required to avoid the simultaneous provision of confusing signals.
30. There is currently no provision for remotely controlled pyrotechnic signals. If pyrotechnic signals are required, it is likely that they will only be available from ATC.
31. It is expected that the OWP will be located in the VCR or Digital VCR, unless an operational reason determines a different location is needed.

¹² Refer to RA 3512 – Permanent Fixed Wing Aerodrome – Obstacle Environment

¹³ Refer to RA 3590 – Maintenance and Safeguarding

RA 3291 – Precision Approach Radar

Rationale

There is a requirement to provide a precision approach capability in poor weather conditions.

Contents

3291(1): Precision Approach Radar

3291(2): Precision Approach Radar for Civil Pilots

Regulation 3291(1)

Precision Approach Radar

3291(1) Controllers **shall** provide Precision Approach Radar (PAR) approaches in accordance with (iaw) specified procedures.

Acceptable Means of Compliance 3291(1)

Precision Approach Radar

1. When a controller is providing a PAR they **should**:
 - a. **Range Selection.** Select an appropriate range scale that will allow accuracy to be maintained throughout the approach. When an Air System is within 4 nm of touchdown, PAR **should** be conducted using the 5 nm range selection in order to maintain the appropriate accuracy when reporting elevation positions; the 3 nm and 1 nm range scales **should not** be used.
 - b. Set appropriate Decision Height ► / Decision Altitude ◀ as obtained from the pilot.
 - c. **Prior to Descent.** Obtain a readback of the correct altimeter setting from the pilot.
 - d. **During Descent.** Prior to obtaining a clearance, obtain a positive notification that the undercarriage is down. There is no requirement to check fixed undercarriage Air Systems, but if the controller is in any doubt a 'check gear, acknowledge' instruction **should** be given.
 - e. **Clearance.**
 - (1) Obtain a clearance from the Aerodrome Controller using the Radar Clearance Line (RCL). The clearance **should** be obtained and repeated verbatim to the pilot; the controller **should** request an acknowledgement of the clearance from the pilot. Unit orders **should** detail the range at which a clearance **should** be obtained.
 - (2) Use the RCL and the PAR frequency simultaneously for the readback of the clearance. If there is a failure of the RCL, the PAR controller **should** request a clearance using the channel intercom facility on the Aerodrome frequency.
 - (3) In the event of the clearance being delayed, make a further attempt to obtain a clearance, or an instruction to break off the approach; this clearance or break-off instruction **should** be passed to the pilot not less than 2 nm from touchdown or the minimum specified in Local / Unit Orders.
 - (4) Instruct the pilot to break-off the approach if a clearance has not been passed to the pilot by 2 nms or as specified in Local / Unit Orders.
 - f. **Approaching / Passing Decision Height ► / Decision Altitude. ◀** Warn the pilot that they are approaching their Decision Height ► / Decision Altitude. ◀ The pilot **should** also be informed when the Air System's radar return passes through the Decision Height ► / Decision Altitude ◀ cursor line.
2. **RN Units.** Specific methods of obtaining and passing a clearance are employed at RN units and controllers operating at these units **should** adhere to Local / Unit Orders.

**Acceptable
Means of
Compliance
3291(1)**

3. **Radar Fault / Failure.** When a major alert, or a Maintenance type minor alert such as "RADAR WORKING WITH ALERTS" is received, the Maintenance Personal Computer **should** be checked immediately, in order to assess the status of the PAR system and its suitability for continued use. Controllers **should** report indications other than 'Green' to the appropriate engineering service authority.
4. In the event that an approach has to be terminated due to a radar fault / failure, the pilot **should** be informed, and the following actions **should** be taken, dependent on the stage of the approach:
 - a. **At any Stage.** Handover the Air System to the Director / Approach controller with appropriate radiotelephony (RT) instructions.
 - b. **Early in the Procedure.** Where possible, arrange for the approach to continue as a Surveillance Radar Approach (SRA), or resume the precision approach if the fault is rectified.
 - c. **Before a Positive Final Clearance Has Been Issued.** Instruct the pilot to contact the Tower controller for clearance to join the visual circuit, ► **make straight in approach** ◀ or break off the approach and execute the Missed Approach Procedure, or to 'fly-through dead-side' (if local procedures permit), depending upon whether the pilot is visual with the Aerodrome.
 - d. **After a Positive Final Clearance Has Been Issued.** Instruct the pilot to continue iaw the issued clearance, or execute the Missed Approach Procedure, depending upon whether the pilot is visual with the aerodrome.
5. **Loss of Radar Contact.** In the majority of cases, a loss of radar contact will be accompanied with an appropriate equipment alert / fault message. If a PAR radar contact is lost for more than 3 secs, the pilot **should** be informed, and further action **should** be taken in the same manner as for a radar fault / failure.
6. If a radar contact is regained within 3 secs, control of the Air System **should** be resumed provided the Air System is within 1 nm of the position that the contact was lost, is correlated and the new contact's track can be directly matched / related to that of its history trails.
7. If a radar contact is regained after 3 secs and / or outside 1 nm of the position that the contact was lost, the PAR can or cannot be resumed as follows:
 - a. **Outside 4 nms.** Outside 4 nms, control of the Air System can be only be resumed once the Air System has been formally re-identified. Identification **should** only take place if the controller considers there is sufficient time to do so. In order to effect identification, the Air System's position **should** be confirmed to the PAR controller by the Director, or if it can be checked, a specific operation of the Air System's transponder.
 - b. **Inside 4 nms.** If radar contact is regained within 4 nms of touchdown, action **should** be taken in the same manner as for a radar fault / failure.
8. **On Completion of the PAR.** On completion of the PAR, the controller **should** use the appropriate facility to inform Director 'Talkdown free'. Prior to conducting the next PAR, the controller **should** select the appropriate range scale. The Reset Default button **should not** be used to reset the display as the OBS mapping will automatically be selected. In the event of an Air System painting on the display prior to the controller stating 'Talkdown free' the controller **should** select the Air System's Data Block and state "*Talkdown free, contact ... (range of the radar return)*".
9. **PAR Azimuth-Only Approaches.** Units may continue to provide PAR Azimuth-Only approaches as an alternative to providing SRA; in such instances the published SRA procedure minima **should** be utilized for the approach.
10. **Track Merge.** In situations where 2 Air System cross tracks in azimuth or elevation at the same range, and the tracks merge, only one radar contact will be displayed until the tracks have diverged sufficiently for the PAR to distinguish and display both Air Systems. In such cases, provided the 're-displayed' track of the PAR Air System can be directly matched / related to its history trail prior to the merge, the PAR can continue. If any doubt exists however, the approach **should** be terminated as detailed in paragraph 4.

**Acceptable
Means of
Compliance
3291(1)**

11. **Conflicting Tracks.** In situations where the controller observes an un-notified radar contact on one element of the PAR display (azimuth or elevation) which is on a conflicting track or in a conflicting position, they **should** immediately check the other element of the PAR display (eg, if a confliction is seen in azimuth, check for related contact in elevation) in order to ascertain the relevance of the apparent confliction and act in accordance with **Table 1** below.

Table 1 – Conflicting Tracks

| Conflicting Track's Behaviour | Action |
|--|--|
| Not displayed in both elements (AZ / EL) | No action required. Contact may be deemed to be outside the coverage area of one PAR element and therefore, no confliction exists. |
| Displayed in both elements - collision risk only apparent in one | No avoiding action required. Traffic Information to be provided to pilot if considered relevant (eg, Radar to Visual joins passing overhead, circuit traffic turning ahead / behind). |
| Collision risk apparent in both elements | Advice on suitable action for collision avoidance passed to pilot together with information on conflicting traffic. Instructions for manoeuvres in a vertical plane should normally only result in stopping descent or applying a climb. Where a heading change is involved, Air Systems should be climbed to the relevant RVC height if the Air System cannot be maintained within PAR Azimuth cover. |

12. Controllers **should** only use 'Small A/C' setting as the use of the 'Large A/C' setting is not currently covered by the PAR System Safety Case.

13. Controllers **should not** change Rain / Clear Mode during an approach. Rain mode **should** only be selected if the weather conditions are such that spurious 'correlated' returns are present.

14. On completion of a runway change, controllers **should** ensure that all runway change alerts are cleared prior to commencing a PAR.

15. Controllers **should** ensure that the whole of the Data Block is visible throughout the PAR.

**Guidance
Material
3291(1)**

Precision Approach Radar

16. **Takeover of Control - Preparation.** The PAR controller will signify their readiness to take over control of an Air System. Before accepting control, the PAR controller will ensure that a correlated (white) radar track is displayed in both (azimuth and elevation) pictures and that the Air System's Data Block is displayed.

17. **Takeover of Control - Actions.** Once an Air System is handed over, the PAR controller will wait for the pilot's initial call. If, after allowing sufficient time to establish RT contact and an unsuccessful radio check, no contact is made, the controller will transmit instructions to the pilot which involve a change of attitude in azimuth or elevation, or if it can be checked, a specific operation of the Air System's transponder. Visual evidence of compliance will confirm that the pilot is receiving their instructions and will enable the controller to continue the PAR after informing the pilot of their intention to do so.

18. **Range Selection.** Provided that the Air System's return and Data Block can be clearly seen, lower range scales can be selected as soon as the Air System reaches the relevant range from touchdown (ie, at 10 nm from touchdown the 10 nm range scale can be selected, at 5 nm the 5 nm range can be selected). If the PAR controller observes another radar contact, whose position and / or track is likely to affect the PAR close to the point where the range would normally be reduced, then the range

**Guidance
Material
3291(1)**

change may be delayed until the controller is satisfied that they can monitor the situation on the lower range setting.

19. **Range Information.** The PAR controller will provide range information at 1 nm intervals for Air Systems 15-18 nm and ½ nm intervals to Air Systems within 15 nm and on final approach. Range information can be derived by reference to the range lines on the azimuth / elevation display, or from the displayed Data Block information.

20. **PAR Coverage.** Due to the volume of airspace covered by the PAR, it is highly likely that a number of other radar contacts will be observed. The azimuth element of the radar system is, in effect, a search radar that radiates in a specific sector, and its vertical coverage is significantly greater than the displayed elevation sector; the effect of this is that high altitude tracks (possibly up to 30 000 ft), may well be detected and displayed on the azimuth picture.

21. **Track Merge.** On some runways, additional radar returns, or 'clutter' may be evident on a semi-permanent basis due to the presence of busy roadways passing over high ground within PAR coverage. In situations where 2 radar returns cross tracks in azimuth or elevation at the same range, the appropriate PAR element (ie, azimuth or elevation) will only 'see' and be able to display, one radar contact during the period that the tracks are 'merged.' The PAR will display only one radar contact until the 2 Air Systems have diverged beyond the PAR elements resolution 'bubble' (eg, an over-flying Air System passing directly over an Air System on PAR may result in only one radar contact being displayed in the azimuth picture until the tracks have diverged sufficiently for PAR to distinguish and display both Air Systems). Once the radar contacts are outside the PAR resolution 'bubble, both contacts will be displayed; this will normally take no longer than 2 or 3 secs.

22. **Size of Returns.** The size of the radar return remains constant throughout and is not dependent on the size of the Air System being controlled. The widths of the radar contacts, centreline and glidepath, as displayed by the PAR system, are very similar in size and, as such, even very slight deviations from the indicated glidepath (GP) or centreline (CL) can give an illusion of being more significant than they actually are. Therefore, there can be a temptation to apply an excessive number of corrective turns / height adjustments to Air System that have, in real terms, moved only a small distance from the desired flightpath and controllers will take this into account when providing GP / CL correction advice to pilots.

23. **Data Block.** A Data Block, designated by the controller, provides additional information and assists the controller in confirming that the correct contact has been correlated in both azimuth and elevation. Unlike Secondary Surveillance Radar labels, Data Blocks are not universally 'tied' to the contact Air System. Temporary loss of the Data Block, or an observed 'jump' to another contact, is not an indication of a radar fault. In cases where 2 Air Systems diverge from each other (eg a formation split, or a track crossing above or below) it will take a finite amount of time, dependent on the relative speed of the separation, for the radar to be able to distinguish and display separate radar contacts for each element; once the second contact is displayed it is possible for the Data Block to become attached to the 'detaching' contact, rather than the contact of the Air System that is being controlled.

24. **Azimuth Control.** Adjustments to heading in order to maintain the Air System on the CL will decrease as range decreases during the approach. Controllers may consider this when judging the size of heading corrections and avoid using small heading changes at range unless a finely tuned adjustment is required. The aim is to guide the Air System smoothly onto the CL before Decision Height ►/ Decision Altitude ◀ and to maintain it in that position. When the Air System passes Decision Height ►/ Decision Altitude, ◀ the information the controller passes becomes advisory, and the controller will only pass the direction of turn and the number of degrees. The 2° and 5° azimuth lines (marked in blue) diverge either side of the CL from touchdown, to assist the controller in determining the azimuth position. Heading changes will be assessed using the trend information gained from monitoring the track history 'trail'. Track histories also show the rate of correction to the centreline. The Air System's position in relation to the CL will be described as follows:

**Guidance
Material
3291(1)**

► **Table 2** ◀ PAR Azimuth Interpretation

| Azimuth Position | Interpretation |
|-------------------------------|--|
| “On CL” | When the radar return is on, or touching, the CL. Note: The CL marked on the display is 50 ft wide. |
| “Slightly Right / Left of CL” | When the radar return is between the CL and the 2° azimuth line, but not touching either. |
| “Right / Left of CL” | When the radar return is between the 2° and 5° azimuth lines, or touching either. |
| “Well Right / Left of CL” | When the radar return is outside the 5° azimuth lines. |

25. **Elevation Control.** In circumstances where a late handover has taken place, it is permissible for the PAR controller to initiate descent followed immediately by a request to readback the appropriate altimeter setting. A warning that the Air System is approaching the GP will be relayed to the pilot, as well as an instruction to begin descent. Accepting that allowances have to be made for the type of Air System and approach speed, this warning will normally be issued as the Air System reaches 200 ft below the GP. The instruction to begin descent may be given at a range commensurate with the performance of the Air System. As the Air System descends, the pilot will be advised of their Air System’s position in relation to the GP and its rate of correction (trend), to which they will apply their own adjustments to the Air System’s rate of descent. This rate of correction (*rapidly, nicely, slowly, not correcting*) can be estimated by monitoring the movements of the track history ‘trail’. There can be large fluctuations in the height information provided by PAR Data Block (particularly with larger Air System or formations); therefore, controllers will concentrate on interpreting the overall trend of the descent, rather than report ‘snapshots’ based on single height indications. Where possible, GP information will be given down to 50 ft below the published Procedure Minimum. The Air System’s position in relation to the GP is described as follows:

► **Table 3** ◀ PAR Glidepath Interpretation

| Glidepath Position | Interpretation |
|------------------------------------|---|
| “On GP” | When the radar return is on, or touching, the GP cursor. <i>Note: To ensure the appropriate reporting accuracy, the final 4 nm of the approach may be controlled using the 5 nm range scale.</i> |
| “Slightly Above / Below GP” | When the radar return is no longer touching the GP, but the height information on the Data Block indicates that it is within 60 ft. |
| “Above / Below GP” | When the height information on the Data Block indicates that the Air System is between 61 ft and 100 ft from the GP. |
| “Well Above / Below GP” | When the height information on the Data Block is greater than 100 ft from the GP. |
| “Dangerously Below GP Acknowledge” | When the radar return touches, or is considered to be descending rapidly towards, the Lower Safe Limit Line Cursor (LSLLC). An acknowledgement is required from the pilot. |

**Guidance
Material
3291(1)**

26. **LSLLC.** An LSLLC is provided on the elevation display to assist the controller in determining when an Air System is approaching the lower limits of the PAR procedure. The position of LSLLC is determined for each runway and is calculated on figures provided by No1 AIDU based on the Obstacle Clearance Surface for the lowest approved GP angle of the runway in use. The LSLLC will only be set by engineering staff.
27. An Air System approaching Decision Height ► / **Decision Altitude** ◀ below GP may approach the LSLLC before the criteria for “Below / Well Below” are met. In this situation, advice on proximity to the LSLLC will take priority as Air Systems will be operating close to the limits of the PAR procedure.
28. Where possible, controllers will avoid passing instructions which result in co-incident capture of centreline and GP to minimize pilot workload.
29. **Clearances.** It is the responsibility of the PAR controller to ensure that a clearance appropriate to the type of approach is obtained. In the event of a delayed clearance, while obtaining the delayed clearance at 2¼ nm will normally suffice, the range may need to be increased for faster Air Systems in order to ensure the issue of a clearance no later than 2 nm.
30. **Late Handovers.** Controllers will consider carefully their allocation of priorities in order to resolve the situation and will control the Air System by issuing positive control instructions before attending to administrative matters. In some circumstances turn and descent instructions may have to be initiated in one transmission, and while it is accepted that both controller and pilot workload will be increased, controllers will take care not to unduly overload the pilot.
31. **Formations.** Whilst Air Systems are in close formation, the PAR tracks the centre of the formation rather than displaying the position of the lead and / or individual formation elements; in real terms, the effect of this is negligible and is similar to the way larger Air Systems (eg C17) are tracked. When a formation splits, the effect on the radar is similar to the ‘Merged Contacts’ situation, where the radar will only be able to display one radar contact until individual formation elements have separated beyond the radar’s resolution ‘bubble’. During this portion of a formation split, controllers will be aware of, and thus ready to anticipate, a possible ‘jump’ in the displayed positions as the single radar contact becomes 2 or more separate contacts.
32. **Separation / Avoidance of Other Contacts.** There are no separation minima to be maintained by the PAR controller as it is the responsibility of the Director and / or local operating procedures to ensure that the prescribed separation requirements are met. The PAR controller’s duties will provide the pilot with the necessary information to avoid a collision rather than to maintain any specified separation minima.
33. **Built In Test Monitoring System.** The PAR has a continuous Built In Test monitoring system, which provides the operator with an indication of a change in the radar’s condition. Alert messages are provided visually via the display monitor and, in the case of major alerts, an audio alarm will also sound. The alerts provided can either be of an advisory nature, or can be used to alert the operator to minor or major problems with the radar as follows:
- a. **Advisory / Minor Alerts.** Advisory and minor alerts are displayed in normal video and provide information about the system which does not adversely affect the current performance criteria of the radar.
 - b. **Major / Critical Alerts.** Major / critical alerts are displayed in inverse (ie, highlighted) video and are accompanied by an audible alarm. These alerts provide warnings of radar or system malfunctions, or combination of malfunctions, which prevent the PAR operating to specification, or which could adversely affect the performance criteria. The receipt of a major alert in itself does not necessarily require the approach to be terminated; some alerts, such as “DAS REDUNDANCY NOT AVAILABLE” (ie, one of the 2 radar consoles is not available for use) simply indicate that a parallel / standby element of the system has failed or has been disconnected, but the radar can still be used.
34. **Moving Target Indicator (MTI) Marker.** The PAR relies on the receipt of a continuous signal from the MTI Markers to confirm the correct alignment of the radar

**Guidance
Material
3291(1)**

system. If the radar is misaligned or loses sight of the MTI Marker for a prolonged period of time the controller will receive a 'Major Alert' "MTI REFLECTOR OUT OF TOLERANCE" message on the display. The equipment resets itself automatically as soon as the MTI signal is received again.

35. **Aircraft Target Size.** The PAR has 2 processing algorithms, 'Large A/C' and 'Small A/C'. The default algorithm for the initial detection of all Air Systems is 'Small', and this is the normal setting to be used when designating (tagging) individual Air Systems, irrespective of the actual size. In some circumstances, when controlling larger Air Systems with 'Small A/C' selected, additional 'ghost' images, (also known as buddy tracks) may be observed to appear behind the Air System for a short period; the presence of these tracks does not affect the conduct of the PAR and controllers can continue to control the 'tagged' contact.

36. **Rain / Clear Modes.** The PAR has two modes of operation, CLEAR mode and RAIN mode. The purpose of RAIN mode is to prevent heavy rainfall, or other precipitation, being displayed as correlated returns. Selection of RAIN mode reduces the maximum useable range of the radar by 5 nm (ie to 15 nm). Following any toggle of Rain / Clear Mode the system processor is reset, causing all targets to disappear from the screen. Target data will reappear within a few seconds of the toggle (typically 4-5 sec, but could be up to 10 sec).

37. **PAR Azimuth Only.** Due to the manner in which PAR operates, it is highly unlikely that the elevation element of the system would ever fail in isolation, or fail in such a way that the alert message indications would still permit the system to be used 'Azimuth-Only'.

**Regulation
3291(2)**

Precision Approach Radar for Civil Pilots

3292(2) Controllers **shall not** offer PAR approaches to civil pilots.

**Acceptable
Means of
Compliance
3291(2)**

Precision Approach Radar for Civil Pilots

38. Controllers **should not** assume that a civil pilot has been authorized and trained to fly a PAR.

39. If the captain of a civil Air System specifically requests a PAR, the approach **should** be provided.

**Guidance
Material
3291(2)**

Precision Approach Radar for Civil Pilots

40. Nil.

Intentionally Blank for Print Pagination

RA 3292 - Instrument Landing Systems Monitoring

Rationale

There is a requirement to provide a precision approach capability in poor weather conditions.

Contents

3292(1): Instrument Landing Systems Monitoring

Regulation 3292(1)

Instrument Landing Systems Monitoring

3292(1) Controllers **shall** provide Instrument Landing Systems (ILS) monitoring in accordance with (iaw) specified procedures.

Acceptable Means of Compliance 3292(1)

Instrument Landing Systems Monitoring

1. Aviation Duty Holders **should** decide when ILS approaches are to be monitored and publish this information in Local / Unit Orders.
2. When a controller is providing monitoring of an ILS, they **should**:
 - a. Set appropriate Decision Height ► / Decision Altitude ◀ as obtained from the pilot.
 - b. **Prior to Descent.**
 - (1) Obtain readback of correct altimeter setting from the pilot.
 - (2) Obtain positive confirmation that the Air System has acquired the localiser and is descending on the glidepath.
 - c. **During Descent.** Prior to obtaining a clearance, obtain a positive notification that the undercarriage is down. There is no requirement to check fixed undercarriage Air Systems, but if the controller is in any doubt a 'check gear, acknowledge' instruction **should** be given.
 - d. **Clearance.**
 - (1) Obtain a clearance from the Aerodrome Controller using the Radar Clearance Line (RCL). The clearance **should** be obtained and repeated verbatim to the pilot; the controller **should** request an acknowledgement of the clearance from the pilot. Unit orders **should** detail the range at which a clearance **should** be obtained.
 - (2) Use the RCL and the Talkdown frequency simultaneously for the readback of the clearance. If there is a failure of the RCL, the controller **should** request a clearance using the channel intercom on the Aerodrome frequency.
 - (3) In the event of the clearance being delayed, make a further attempt to obtain a clearance, or an instruction to break off the approach; this clearance or break-off instruction **should** be passed to the pilot not less than 2 nm from touchdown or the minimum specified in local / unit orders.
 - (4) Instruct the pilot to break-off the approach if a clearance has not been passed to the pilot by 2 nms or the minimum specified in Local / Unit orders.
3. **Approaching / Passing Decision Height ► / Decision Altitude. ◀** Warn the pilot that they are approaching their Decision Height ► / Decision Altitude. ◀ The pilot **should** also be informed when the Air System's radar return passes through the Decision Height ► / Decision Altitude ◀ cursor line.
4. **RN Units.** Specific methods of obtaining and passing a clearance are employed at RN units and controllers operating at these units **should** adhere to Local / Unit orders.

**Acceptable
Means of
Compliance
3292(1)**

5. **PAR Radar Fault / Failure.** When a major alert, or a Maintenance type minor alert such as "RADAR WORKING WITH ALERTS" is received, the Maintenance Personal Computer **should** be checked immediately, in order to assess the status of the PAR system and its suitability for continued use. Controllers **should** report indications other than 'Green' to the appropriate engineering service authority.
6. Where ILS monitoring is mandatory, in the event that an approach has to be terminated due to a radar fault / failure the pilot **should** be informed and the following actions **should** be taken, dependent on the stage of the approach:
- At any Stage.** Handover the Air System to the Director / Approach controller with appropriate radiotelephony instructions.
 - Early in the Procedure.** Where possible, arrange for the approach to continue as a Surveillance Radar Approach, or resume the precision approach if the fault is rectified.
 - Before a Positive Final Clearance Has Been Issued.** Instruct the pilot to contact the Tower controller for clearance to join the visual circuit, ► **make straight in approach** ◀ or break off the approach and execute the Missed Approach Procedure, or to 'fly-through dead-side' (if local procedures permit), depending upon whether the pilot is visual with the Aerodrome.
 - After a Positive Final Clearance Has Been Issued.** Instruct the pilot to continue iaw the issued clearance, or execute the Missed Approach Procedure, depending upon whether the pilot is visual with the aerodrome or not.
7. **Loss of Radar Contact.** In the majority of cases, a loss of radar contact will be accompanied with an appropriate equipment alert / fault message. If a radar contact is lost for more than 3 seconds, the pilot **should** be informed, and further action **should** be taken in the same manner as for a radar fault / failure.
8. If a radar contact is regained within 3 seconds, control of the Air System **should** be resumed provided the Air System is within 1 nm of the position that the contact was lost, is correlated and the new contact's track can be directly matched / related to that of its history trails.
9. If a radar contact is regained after 3 seconds and / or outside 1 nm of the position that the contact was lost, the ILS monitor can or cannot be resumed as follows:
- Outside 4 nms.** Outside 4 nms, control of the Air System can be only be resumed once the Air System has been formally re-identified. Identification **should** only take place if the controller considers there is sufficient time to do so. In order to effect identification, the Air System's position **should** be confirmed to the controller by the Director, or if it can be checked, a specific operation of the Air System's transponder.
 - Inside 4 nms.** If radar contact is regained within 4 nms of touchdown, action **should** be taken in the same manner as for a radar fault / failure.
10. **On Completion of the ILS.** On completion of the ILS, the controller **should** use the appropriate facility to inform Director 'Talkdown free'. Prior to conducting the next ILS, the controller **should** select the appropriate range scale.
11. Where PAR is being used for ILS monitor the Reset Default button **should not** be used to reset the display as the OBS mapping will automatically be selected. In the event of an Air System painting on the display prior to the controller stating 'Talkdown free' the controller **should** select the Air System's Data Block and state "*Talkdown free, contact ... (range of the radar return)*".

**Guidance
Material
3292(1)**

Instrument Landing Systems Monitoring

12. Nil.

RA 3293 – Surveillance Radar Approach

Rationale

A Surveillance Radar Approach (SRA) is a non-precision approach that allows an Aircraft to conduct an approach in Instrument Meteorological Conditions (IMC) without a precision approach aid. Following a set of laid down control procedures ensures that descent below Safety Altitude in IMC is safe and the Risk to Life associated with controlled flight into terrain is minimized. Controllers are required to understand their responsibilities when controlling Aircraft electing to perform this type of approach.

Contents

3293(1): Surveillance Radar Approach

Regulation

3293(1)

Surveillance Radar Approach

3293(1) Aviation Duty Holder-Facing organizations **shall** ensure SRAs are provided in accordance with (iaw) specified procedures.

Acceptable Means of Compliance

3293(1)

Surveillance Radar Approach

1. **Published Procedure.** SRAs **should** be conducted according to the procedures published in the relevant Terminal Approach Procedure Charts.
2. **SRA Termination and Update Rates**¹. A Surveillance system providing the positional data for SRAs **should** provide regular updates with at least the following update periodicity:
 - a. SRA terminating at 2 nm from threshold; 6 second update periodicity.
 - b. SRA terminating at 1 nm from threshold; 4 second update periodicity.
 - c. SRA terminating at 0.5 nm, or less, from threshold; 3 second update periodicity.
3. **Range and Height Data.** Unit Air Traffic Management staff **should** produce advisory range and height guidance that depicts range from threshold and the correlated height for the direction of the approach. This **should** be immediately available to the Controller, either on the surveillance screen or on a separate reference document.
4. **QNH approaches.** Where SRAs are conducted using QNH, references to height in this RA **should** be converted to Altitude utilizing the Threshold Elevation.
5. **Controller Actions.** When controlling a SRA, Controllers **should**:
 - a. Identify the Aircraft.
 - b. Obtain readback of the correct altimeter setting from the pilot before commencing final approach.
 - c. Pass to the pilot ranges from the threshold together with pre-computed advisory heights at intervals of ½ nm, until the Aircraft reaches a range equivalent to the pilot's Minimum Descent Height (MDH), after which only ranges from the threshold at intervals of ½ nm **should** be given.
 - d. Pass to the pilot heading instructions to intercept, and maintain, the centreline until the Aircraft reaches the Missed Approach Point (MAPt).
 - e. Obtain a notification that the undercarriage is down prior to obtaining a clearance. There is no requirement to check fixed undercarriage Aircraft, but if the Controller is in any doubt a 'check gear, acknowledge' instruction **should** be given.
 - f. Obtain clearances in the same manner as RA 3291².

¹ DefStan 00-972: Military Air Traffic Services Equipment Safety and Performance Standards (Aerodrome, Terminal and Naval Air Traffic Services) with supporting extracts from CAP 670: Air Traffic Services Safety Requirements Part C, Section 3: SUR04: Requirements for Primary Radar Systems para SUR04.17 Note 2.

² Refer to RA 3291 – Precision Approach Radar.

**Acceptable
Means of
Compliance
3293(1)**

- g. Advise the pilot that they are approaching their MDH. ► When the MDH is within ½ nm of the MAPt the phrase 'approaching MDH' is not included. ◀
- h. Advise the pilot that they are approaching the MAPt. ► After passing the MAPt only the ◀ direction of turn and number of degrees related to the Aircraft position from the projected Runway centreline ► **should be passed.** ◀
- i. Terminate the SRA iaw paragraph 2.

6. **Elevation Control.** Descent **should** be commenced at a range and height from the threshold which corresponds to the required rate of descent. The Controller **should** pass pre-computed advisory heights with range information to assist the pilot in maintaining a rate of descent for a glidepath (GP) angle equivalent to the published procedure, and to meet all associated restrictions³.

7. **Centreline Information.** The method for assessing centreline information will vary dependent on the nature of the surveillance display and as such, Front Line Commands **should** issue coherent policy that will ensure consistency of service across all units.

8. **Loss of Radar Contact.** If a Controller is unable to maintain identification of the Aircraft, the approach **should** be terminated. The pilot **should** be informed of the loss of radar contact, and a Missed Approach Procedure initiated if the pilot cannot continue their approach visually.

9. **Separation / Avoidance of Other Contacts.** If the SRA Controller observes a radar contact which is in conflict with the track of the Aircraft completing an SRA, they **should** immediately check the elevation indication if available. If collision Risk is apparent in both azimuth and elevation (either assessed from elevation indication, or due to unknown elevation), advice on suitable action for collision avoidance **should** be passed to the pilot together with information on conflicting traffic. Instructions for manoeuvres in a vertical plane **should** normally only result in stopping descent or applying a climb. Where a heading change is involved, the Aircraft **should** be climbed to the relevant height according to the Surveillance Minimum Altitude Chart / Radar Vector Chart.

10. **Surveillance System.** There is an increased Risk of Mid Air Collision when only a co-operative surveillance system is available due to non-transponding traffic not being detected. When pilots are conducting SRAs they are likely to have a reduced lookout. Therefore, units **should** apply RA 3241⁴ when considering the provision of SRAs using only a cooperative surveillance system.

**Guidance
Material
3293(1)**

Surveillance Radar Approach

11. When providing a SRA, the Controller passes instructions and information to the pilot to enable them to follow a pre-determined approach path to a position from which a visual landing or circuit can be made. This type of approach is not as accurate as a precision approach in that no electronic GP information is available, nor is there a similar degree of accuracy in azimuth.

12. **Azimuth control.** Adjustments to headings are made with the intention of guiding the Aircraft smoothly onto the centreline before MDH and maintaining this azimuth position. The update rate of the surveillance system in use needs to be considered when assessing corrective headings.

13. **Elevation control.** Procedures designed according to the International Convention on Civil Aviation's Procedures for Air Navigation - Aircraft Operations (ICAO PANS-OPS) utilize measures for ensuring safe separation from obstacles, including Threshold Crossing Height (TCH), SDF and MOCA. Units providing PANS-OPS designed procedures need to ensure that advisory heights passed as vertical guidance during a SRA do not contradict the requirements of the procedure. For example, advisory heights calculated using 318 ft per nm to approximate a 3.0° GP, will not be suitable if they result in vertical guidance that is lower than a SDF or MOCA. Instead, units may elect to use more accurately calculated advisory heights to allow Controllers to issue continuous descent advice that meet the criteria of any

³ Such as Minimum Obstacle Clearance Areas (MOCA) and Step-Down Fixes (SDF).

⁴ Refer to RA 3241 – Secondary Surveillance Radar Alone Operations.

**Guidance
Material
3293(1)**

restrictions in the procedure. An exemplar table for SRA advisory range and height guidance, based on the calculation of 265 ft per nm for a 2.5° GP and 318 ft per nm for a 3.0° GP, to a TCH of 50 ft is included within Table 1 in Annex A.

14. **Separation / Avoidance of Other Contacts.** The application of the type of Air Traffic Control Service provided rests with the Director (or equivalent role), not with the SRA Controller. The SRA Controller will provide the pilot with the necessary information to avoid a collision rather than to maintain any specified separation distance.

Annex A to RA 3293

Table 1. SRA Advisory Range and Height Guidance Example for TCH 50 ft.

| Range (from threshold) | 2.5° GP Height (See Note 1) | 3° GP Height (see Note 2) |
|------------------------------|-----------------------------------|---------------------------------|
| 0 | 50 | 50 |
| 0.5 | 190 | 210 |
| 1.0 | 320 | 370 |
| 1.5 | 450 | 530 |
| 2.0 | 580 | 690 |
| 2.5 | 720 | 850 |
| 3.0 | 850 | 1010 |
| 3.5 | 980 | 1170 |
| 4.0 | 1110 | 1330 |
| 4.5 | 1250 | 1490 |
| 5.0 | 1380 | 1640 |
| 5.5 | 1510 | 1800 |
| 6.0 | 1640 | 1960 |
| 6.5 | 1780 | 2120 |
| 7.0 | 1910 | 2280 |
| 7.5 | 2040 | 2440 |
| 8.0 | 2170 | 2600 |
| 8.5 | 2310 | 2760 |
| 9.0 | 2440 | 2920 |
| 9.5 | 2570 | 3080 |
| 10.0 | 2700 | 3230 |

Note 1: Calculation method. $((\text{Range}) \times (\text{Accurate } 2.5^\circ \text{ ft per nm})) + (\text{TCH}) = (\text{height})$, round up to nearest 10 ft. The accurate 2.5° ft per nm equals 265 ft and the TCH is a procedure design standard 50 ft.

Note 2: Calculation method. $((\text{Range}) \times (\text{Accurate } 3^\circ \text{ ft per nm})) + (\text{TCH}) = (\text{height})$, round up to nearest 10 ft. The accurate 3° ft per nm equals 318 ft and the TCH is a procedure design standard 50 ft.

RA 3295 – Required Navigation Performance Approach – Controller Responsibilities

Rationale

A Required Navigation Performance Approach (RNP APCH)¹ provides an Air System with the means of descending below Safety Altitude in Instrument Meteorological Conditions (IMC) to conduct an approach using a Global Navigation Satellite System (GNSS) and / or Satellite Based Augmentation System. Following a published procedure ensures that descent below Safety Altitude in IMC is safe and the Risk to Life associated with controlled flight into terrain is minimized. Controllers are required to understand their responsibilities when controlling Air Systems electing to perform this type of approach.

Contents

3295(1): Required Navigation Performance Approach - Controller Responsibilities

Regulation 3295(1)

Required Navigation Performance Approach – Controller Responsibilities

3295(1) Controllers **shall** control Air Systems electing to perform RNP APCH in accordance with (iaw) specified procedures.

Acceptable Means of Compliance 3295(1)

Required Navigation Performance Approach - Controller Responsibilities

1. RNP APCH are pilot-interpreted precision and non-precision approaches and **should** be handled in the same way as other precision and non-precision approaches.
2. Standard Air Traffic Control (ATC) procedures for sequencing and separating Air Systems **should** be applied at all times during RNP APCH. Standard Instrument Flight Rules (IFR) separation **should** be provided for all IFR traffic.
3. Air Systems **should** normally be cleared to an Initial Approach Fix (IAF) where the approach commences via the appropriate Standard Instrument Arrival (STAR) route. Pilots may request vectors, where these are available, for the IAF or may elect to self-position by requesting a direct routing to an appropriate STAR point before the Final Approach Fix (FAF).
4. Once an approach has commenced, the Air Systems **should** be allowed to self-position for the approach. Vectors **should not** be given unless safety is at risk.
5. Controllers **should not** issue, and pilots **should not** accept, vectors to any point inside the FAF at any time. When necessary for operational or traffic reasons, Air Systems may be vectored to a point such that the Air System is established on the final approach track no later than 2 nm before the FAF. Air Systems to be vectored to the final approach track in this way **should** be informed of this requirement as soon as possible.
6. **Altimeter Setting.** RNP APCH Terminal Charts are published using 'altitude' constraints not height. QFE operations are not supported by most GPS databases. Sequencing of altitude-based navigation legs requires the use of (QNH) altitudes. Controllers **should** provide a QNH altimeter setting when a pilot is flying an RNP APCH. Pilots **should** fly the RNP APCH based upon the QNH and expect to fly to Decision Altitude / Minimum Descent Altitude minimums to avoid confusion.

Guidance Material 3295(1)

Required Navigation Performance Approach – Controller Responsibilities

7. Further information can be found in the following documents:
 - a. ICAO Doc 9613 - Performance-based Navigation Manual.

¹ Approach applications based on GNSS are classified RNP APCH iaw the Performance Based Navigation (PBN) concept and include existing RNAV(GNSS) approach procedures designed with a straight segment.

**Guidance
Material
3295(1)**

- b. CAP 413 - Radiotelephony Manual.
 - c. CAP 773 - Flying RNAV (GNSS) Non-Precision Approaches in Private and General Aviation Aircraft.
 - d. RA 1380 - Performance Based Navigation.
 - e. RA 2380 - Performance Based Navigation Operations.
8. **Point-In-Space (PinS) RNP APCH.** PinS RNP APCH are Helicopter-only approaches. They are shorter, steeper and flown slower than normal RNP APCH. They are designed for Helicopter Landing Sites where there is no ATC and / or Controlled Air Space. The FAF are also lower than the normal RNP APCH.

RA 3301 – Meteorological Information

Rationale

The availability of accurate, up-to-date meteorological (met) information is crucial for the safe conduct of flights.

Contents

3301(1): Meteorological Information

3301(2): Meteorological Information Requirements

Regulation

3301(1)

Meteorological Information

3301(1) Controllers **shall** only use met information derived from official sources¹.

Acceptable Means of Compliance

3301(1)

Meteorological Information

1. Only met information derived from official sources **should** be used for Air Traffic Management (ATM) purposes.

Guidance Material

3301(1)

Meteorological Information

2. Nil.

Regulation

3301(2)

Meteorological Information Requirements

3301(2) Units **shall** arrange for specified met information to be available to controllers.

Acceptable Means of Compliance

3301(2)

Meteorological Information Requirements

3. Units **should** determine the level of met support required in accordance with JSP ► 465 Part 2 Volume 3, **Guidance on Defence Meteorological Services**. ◀ As a minimum, this **should** include:

a. Terminal Air Traffic Control (ATC):

(1) Actual weather reports for the Aerodrome at hourly intervals (or at such lesser intervals as may be required) during the period that flying is in progress or the Aerodrome is likely to receive diverted Air Systems.

(a) Actual Weather Reports **should** include cloud coverage and heights (to be specified as Few (FEW), Scattered (SCT), Broken (BKN), Overcast (OVC) and feet above Aerodrome level respectively, beginning with the lowest layer), surface visibility, Aerodrome QFE and QNH and any other relevant information. The surface wind speed and direction can be read direct from the wind dials in the Visual Control Room (VCR) but ► **should** ◀ be displayed in the Approach Control Room (ACR).

(2) Special deterioration or improvement reports, additional to above, when significant changes to wind, visibility, weather or cloud occur. Commanders **should** liaise with their Senior Met Officers to define the critical values which will determine when the Met Office will make these reports to ATC.

(a) For special deterioration or improvement reports, a change of a QNH / QFE value of half a hectopascal (0.5 hPa) or greater

¹ For the purpose of this regulation, when operating in the UK or in established bases overseas, the official source will be the UK Met Office. In other operating scenarios, official sources will also include authoritative allied partners (ie 5-EYES and, potentially, NATO allies).

**Acceptable
Means of
Compliance
3301(2)**

since the previous report **should** be considered a significant weather change at Aerodromes where this is deemed operationally desirable. Otherwise changes of one hectopascal or greater will be considered as significant weather calling for a special report.

- (3) Forecasts of met conditions over a specified area surrounding the Aerodrome. The extent of the area, the frequency of issue and the content of forecasts **should** be as decided by the Commander, or as shown in single-Service Orders.
 - (4) Forecasts for nominated Aerodromes as required for possible diversion action and the most recent met reports from selected Aerodromes in the vicinity.
 - (5) In the UK, Regional Pressure Setting (RPS) values for appropriate Altimeter Setting Regions (ASR).
 - (6) Warnings of reported or forecast weather considered to be hazardous to the safety of Air Systems, either in flight or on the ground.
 - (7) Advice on met factors likely to affect the diversion of Air Systems.
- b. **Air Traffic Control Centre:**
- (1) Weather reports at intervals of not greater than one hour from specified Aerodromes within the Flight Information Region (FIR) and, where necessary, Aerodromes adjacent to the region.
 - (2) Special weather reports (SPECIs) at these Aerodromes as soon as they are received.
 - (3) Forecasts for designated Aerodromes within the FIR.
 - (4) Forecasts of met conditions, including details of cloud, icing, high-level winds, etc, over the FIR, and amended forecasts when necessary.
 - (5) In the UK, RPS values for ASR within the FIR, and, as required, for altimeter setting regions within adjacent FIR. These values are passed hourly to the air traffic control officer for transmission to Air System, either on a routine broadcast or on request.
 - (6) Warning of weather elements.
- c. **Air Surveillance And Control System (ASACS).** Provision of met information for ASACS units **should** include:
- (1) Aerodrome weather reports updated at timely intervals (as detailed in orders pertinent to the ASACS unit and / or system in operation) from specified Aerodromes within the FIR and, where necessary, in adjacent regions.
 - (2) Special weather reports (SPECIs) at these Aerodromes as soon as they are received.
 - (3) Forecasts for designated Aerodromes within the FIR.
 - (4) Forecasts of met conditions, including details of cloud, icing, high-level winds, sea states etc, over the FIR, and amended forecasts when necessary.
 - (5) In the UK RPS values for ASR within the FIR, and, as required, for altimeter setting regions within adjacent FIRs. These values are updated on an hourly basis (or during exercises, as specified in Operation Orders) to enable transmission to air systems on a routine broadcast or on request.
4. Whenever met information is transcribed from any met form, the accuracy of the transcription **should** be independently, and the form signed to this effect.
 5. Where there are no Met Office trained staff at an Aerodrome, the Aerodrome QFE and QNH **should** be determined through the use of correction tables by a competent person using Met Office approved equipment.

**Guidance
Material
3301(2)**

Meteorological Information Requirements

6. Nil.

Intentionally Blank for Print Pagination

RA 3302 – Altimeter Settings

Rationale

Aircraft use altimeters to assess vertical distance from a specified datum; inaccurate altimeter settings may present an increased Risk to Life by loss of separation between Aircraft and / or terrain. Provision of the appropriate altimeter setting ►◄ to Aircraft ► when providing UK Flight Information Services (UK FIS) or the North Atlantic Treaty Organization (NATO) Control Rules◄ helps reduce the Risk of loss of separation due to flight at the incorrect level.

Contents

3302(1): Altimeter Settings

Regulation 3302(1)

Altimeter Settings

3302(1) ► Aviation Duty Holder-Facing Organizations, Accountable Manager (Military Flying)-Facing Organizations and Heads of Establishment (HoE) **shall** ensure that appropriate altimeter pressure settings are used when providing UK FIS or NATO Control Rules.◄

Acceptable Means of Compliance 3302(1)

Altimeter Settings

1. ►◄ The appropriate altimeter pressure setting ►◄ as defined in the UK Aeronautical Information Publication (UK AIP) ► **should be utilized**◄, except:
 - a. When providing ► services◄ to ►◄ Aircraft flying in the vicinity of a ► MOD Aerodrome or unlicensed non-MOD Aerodrome¹◄, landing, taking off or ► conducting◄ visual circuits. ► Under these circumstances, the appropriate altimeter pressure setting, as defined by the HoE, **should** be used.
 - (1) The HoE **should**, in conjunction with permanently based Aviation Duty Holders / Accountable Managers (Military Flying), determine the most appropriate altimeter pressure setting (QFE or QNH) for the Aerodrome and ensure this is reflected in the UK Military AIP (Mil AIP), UK AIP (where appropriate), Defence Aerodrome Manual and unit / local orders.
 - (2) The simultaneous mixed use of QFE and QNH in the visual circuit **should not** be permitted, however this does not prevent an isolated approach or departure on the QNH at an Aerodrome that operates on QFE (or vice versa) provided the Aircraft is not intending to join the visual circuit.
 - (3) At Aerodromes operating on QFE, the QFE datum to be used is as follows:◄
 - (a) On an Aerodrome without a designated Runway the QFE datum for all procedures **should** be the Aerodrome Elevation (Aerodrome QFE).
 - (b) In all other circumstances the QFE datum for all procedures **should** be the Touchdown Zone Elevation for the Runway in use (Runway QFE). Where more than one Runway is in use for simultaneous instrument and visual procedures, the QFE relevant to the Instrument Runway **should** be used. Mixed use of QFEs **should not** be permitted.
 - b. When providing services to Aircraft operating outside the UK Flight Information Region (FIR), ► the appropriate altimeter pressure setting, as defined by local, national and / or international requirements, **should** be used.◄
 - c. When ► providing services to◄ Aircraft within a defined Operational / Exercise (Op / Ex) area, ►◄ the Force QNH, as defined in the relevant Op / Ex Order, ► **should** be used.◄

¹ ► In the context of this RA, unlicensed non-MOD Aerodromes include Heliports and Helicopter Landing Sites.◄

**Acceptable
Means of
Compliance
3302(1)**

(1) Where appropriate for the general conduct of the Op / Ex, Force QNH **should** be used at all times whilst clear of non-segregated Controlled Airspace (CAS). However, if a Force QNH is required for lower level flight, but airspace structure dictates that flight on Standard Altimeter Setting (SAS) at higher Altitudes is also necessary, a 'Force Transition Altitude (TA) and Transition Level (TL)' (providing adequate terrain and airspace separation) **should** be set and promulgated within the same Op / Ex Orders.

(2) Validity of Force QNH **should** be for as long a period of time as possible (up to 6 hour periods), preferably covering likely flying waves. As a minimum, and only for Operations with a **►Tactical Command and Control (Tac C2) Agency◄** in communication with all participants, Force QNH **should** be issued and promulgated at least an hour in advance, valid for one hour (akin to current Regional Pressure Setting (RPS) procedures).

(3) Force QNH **should** be promulgated through Met Office channels as agreed by Op / Ex planners.

d. When providing **►services◄** in the maritime environment, the relevant QNH **should** be used in accordance with (iaw) BRd 766, Embarked Aviation Operating Handbook.

2. **►◄** The **►relevant◄** altimeter pressure setting, as defined in **►mid-level◄** or local orders, **►should be◄** set on **►the◄** Air Traffic Management Equipment being utilized to provide **►UK FIS or NATO Control Rules.◄◄**

3. Where QFE is below 950 Hectopascals (hPa), QNE information **should** be provided to pilots of Aircraft whose altimeters cannot be set to below 950 hPa. A QFE / QNE table **should** be held by **►units that provide UK FIS or NATO Control Rules.◄◄**

4. When Aerodrome QNH is passed to Aircraft, the **►◄ Aerodrome Elevation ►or threshold Elevation should only be passed if the Aircraft is suffering an emergency or it is requested by the pilot.◄** When operating in the maritime environment, the flight deck Elevation **should not** be passed, unless specifically requested or required **►◄**.

5. **Transition Level.** Air Traffic Control (ATC) units **should** establish the TL on the basis of the relationship between the SAS pressure datum (1013.25 hPa) and the Aerodrome QNH. ATC **should** maintain an up-to-date readout of the TL and be prepared to pass it on request or iaw unit / local orders. Where two or more Aerodromes are in close proximity, a common TL **should** be established.

6. The TL **should** be the lowest Flight Level available for use above the TA and **should** be at least 1000 ft above the TA to allow both the TA and the TL to be used for flight² whilst maintaining vertical separation. The TL **should** be determined using Annex A, as follows:

a. Within CAS by the controlling authority, where it will normally be based on the QNH of the major Aerodrome.

b. Outside CAS by the Aerodrome, where it will be based on the Aerodrome QNH.

7. **Transition Altitude.** The TA **should** be the Altitude at or below which the vertical position of an Aircraft is controlled by reference to Altitude. **►In the UK, the Transition Altitude is usually 3000 ft³.◄**

8. **Transition Layer.** The Transition Layer **should** be the airspace between the TA and the TL and is at least 1000 ft deep.

9. **►Standard Altimeter Setting.** The SAS assumes a mean sea level pressure of 1013.25 hPa (29.92 inches) and **should** be used when flying above the TA and when flying above 3000 ft AMSL in the UK outside CAS, except when:

a. Flying in conformity with instructions given by ATC, His Majesty's (HM) Ships or an Air Surveillance and Control System (ASACS) unit.

² Subject to terrain and airspace restrictions.

³ **►Refer to UK AIP ENR 1.7.◄**

**Acceptable
Means of
Compliance
3302(1)**

- b. **Completing manoeuvres requiring rapid changes of Altitude or heading (eg aerobatics, spinning and Air Combat Manoeuvring⁴). ◀**

**Guidance
Material
3302(1)**

Altimeter Settings

10. **Hectopascals (hPa).** hPa are the notified unit for measurement of pressure for flying within UK airspace. Altimeter setting values will normally be expressed in hPa, rounded down to the nearest whole hPa, but they can be given in inches of mercury (to the nearest hundredth of an inch) either on request or when it is known that the Aircraft is one in which the altimeter sub-scale is calibrated in inches (▶see the **Flight Information Handbook for a conversion table** ◀). When giving an altimeter setting below 1000 hPa, or in cases where confusion or ambiguity may result, "hectopascals" will be appended to the figures passed.

11. **QFE.** QFE is the corrected barometric pressure for a specified datum. When QFE is set on an altimeter sub-scale, the altimeter will indicate the vertical distance relative to the QFE datum (Height).

12. **Aerodrome QNH.** Aerodrome QNH is the observed pressure at an Aerodrome Elevation corrected for temperature and reduced to mean sea level, using the International Civil Aviation Organization (ICAO) formula. When Aerodrome QNH is passed to Aircraft, the message will include Aerodrome Elevation or touchdown / threshold Elevation as determined by ▶unit / ◀ local orders. When Aerodrome QNH is set on an altimeter subscale, the altimeter will indicate the vertical distance relative to mean sea level (Altitude). ▶ ◀

- a. ▶ ◀
- b. ▶ ◀
- c. ▶ ◀
- d. ▶ ◀
- e. ▶ ◀

13. **Altimeter Setting Regions (ASRs).** ▶ **To make up for any lack of stations reporting actual QNH, the UK has been divided into a number of ASRs for each of which the meteorological office calculates the lowest forecast QNH for each hour.** ◀ The boundaries and names of UK ASRs are shown in ▶ ◀ Military Flight Information Publications (Mil FLIPS) and the UK AIP.

14. **RPS.** The RPS is the lowest forecast QNH within a designated ASR, and is used as an Altitude pressure datum for Aircraft flying at or below the TA, away from Aerodrome circuit and approach patterns. It is available hourly for the period H+0 to H+1 and ▶ ◀ units will maintain a record of the current pressure setting for their local and adjoining regions. The value for the period H+1 to H+2 is available on request from the meteorological office. ▶ ◀ When RPS is set on an altimeter sub-scale, the altimeter will indicate the vertical distance relative to the RPS datum (Altitude).

- 15. ▶ ◀
 - a. ▶ ◀
 - b. ▶ ◀

16. **Force QNH.** Force QNH is the lowest QNH forecast for an Op / Ex area for a defined time-period. It is calculated by a suitably qualified ▶ **Meteorological Officer** ◀ / Forecaster and promulgated to all participating units as directed by the Airspace Controlling Authority.

17. Pilots of Aircraft descending to fly at or below the TA may change from the SAS to the appropriate pressure datum when passing the TL. An exception to this rule has been made for Military Aircraft making a continuous descent for entry into an established instrument pattern. In this case the appropriate QFE ▶ / QNH ◀ may be

⁴ Refer to RA 2327 – Air Combat Manoeuvring, Basic Fighter Manoeuvres and Basic Helicopter Manoeuvres.

**Guidance
Material
3302(1)**

set before descent, providing that level flight will not be recommenced above the TA unless in conformity with instructions given by ATC, ► **HM Ships, or an ASACS unit.** ◀

ANNEX A

Figure 1 - Pressure Setting Table for Determining TL

| Aerodrome QNH (hPa) | TA 3000 ft TL ▶◀ | TA 3000 ft Minimum IFR Cruising Level ▶◀ | TA 4000 ft TL | TA 4000 ft Minimum IFR Cruising Level | TA 5000 ft TL | TA 5000 ft Minimum IFR Cruising Level | TA 6000 ft TL | TA 6000 ft Minimum IFR Cruising Level |
|---------------------------|---------------------------|--|---------------------|---|---------------------|---|---------------------|---|
| 1060 1050 | 30 | 30 | 40 | 40 | 50 | 50 | 60 | 60 |
| 1049 1032 | 35 | 40 | 45 | 50 | 55 | 60 | 65 | 70 |
| 1031 1014 | 40 | 40 | 50 | 50 | 60 | 60 | 70 | 70 |
| 1013 995 | 45 | 50 | 55 | 60 | 65 | 70 | 75 | 80 |
| 994 977 | 50 | 50 | 60 | 60 | 70 | 70 | 80 | 80 |
| 976 959 | 55 | 60 | 65 | 70 | 75 | 80 | 85 | 90 |
| 958 940 | 60 | 60 | 70 | 70 | 80 | 80 | 90 | 90 |

Note 1. Calculation of the TL is based upon:

- a. A Standard setting (1013.25 hPa) from ICAO Doc 7488 Manual of the Standard Atmosphere and European Union Aviation Safety Agency (EASA) Certification Specification - Definitions.
- b. Assumed value of 27.3 ft per hPa derived from a linear correction which is applied to corrected barometric Altitudes and confirmed as being utilized in Aircraft and Air Traffic Service systems, not the rounded value of 30 ft per hPa used in routine operating pressure calculations.

Note 2. Minimum Instrument Flight Rules (IFR) cruising level is iaw semi-circular flight rules.

Intentionally Blank for Print Pagination

► This RA has been substantially rewritten; for clarity no change marks are presented – please read RA in its entirety ◀

RA 3311 – Aircraft Emergency and Crash Procedures

Rationale

Pilots handling an Aircraft emergency are likely to be under an increased workload and stress, resulting in them potentially having reduced spare capacity to be able to make effective decisions and process information correctly. The incorrect handling or lack of appropriate assistance, including the recognition of stress indicators, could exacerbate the situation and result in the delivery of unsafe operations. Therefore, it is vital that Air Traffic Control (ATC) personnel know how to appropriately handle an Aircraft emergency or crash to ensure that the pilot receives the necessary assistance required to achieve the optimal outcome.

Contents

3311(1): Aircraft Emergency and Crash Procedures

Regulation 3311(1)

Aircraft Emergency and Crash Procedures

3311(1) Head of Aviation Duty Holder-Facing Organizations and Accountable Manager (Military Flying)-Facing Organizations and Heads of Establishment **shall** ensure that emergency Aircraft are provided the assistance required.

Acceptable Means of Compliance 3311(1)

Aircraft Emergency and Crash Procedures

Emergency Procedures

1. Throughout all stages of handling an Aircraft emergency the delivery of calm and coordinated instructions are essential and the Controller **should** tailor their actions accordingly to the situation¹ and the pilot's ability to respond.
2. On notification that an Aircraft is suffering an emergency, the Controller **should**:
 - a. Ensure that the pilot has passed the relevant information within the emergency message² below and elicit any that are missing:
 - (1) MAYDAY x3 or PAN PAN x3;
 - (2) Name of the station addressed;
 - (3) Callsign;
 - (4) Type of Aircraft;
 - (5) Nature of the emergency;
 - (6) Intention of the pilot (person-in-command);
 - (7) Present or last known position, Flight Level (FL) / altitude and heading;
 - (8) Pilot experience / qualification;
 - (9) Any other useful information eg endurance remaining, persons on board, Aircraft colour / markings, any survival aids or carrying dangerous goods.
 - b. Inform the pilot to squawk 7700, if possible, and to only acknowledge transmissions that are essential to the Safety of the Aircraft and its occupants.
 - c. Provide the pilot with all the relevant information required to assist them in forming an appropriate plan.
 - d. Inform the pilot of the most suitable Aerodrome available and provide navigational assistance if required, ensuring that the weather conditions, terrain

¹ For example, the Aircraft endurance and / or pilots' qualification.

² Refer to CAP 413 – Radiotelephony Manual, Chapter 8: Emergency Phraseology.

**Acceptable
Means of
Compliance
3311(1)**

and any known obstructions that could affect the Aircraft's transit route and level are considered.

e. Inform Distress and Diversion (D&D)³ and any other ATC units as required and continue to update them up until either the emergency has concluded, or the Aircraft is handed over to another unit.

f. Alert Aerodrome Emergency Services⁴ if the Aircraft is being handled by a Terminal Unit.

g. Advise other Aircraft of the emergency in progress and, where possible, keep them off the frequency being used by the Aircraft in distress. If possible, avoid changing the frequency of the Aircraft in distress once suitable contact is established.

h. Ensure the Supervisor is informed and all relevant details of the Aircraft emergency are recorded in the Air Traffic Watch Log (RAF F6658).

3. If an Aircraft is carrying dangerous goods, all pertinent information **should** be passed to D&D and the Aerodrome Emergency Services without delay.

4. Guidance on the actions and procedures that **should** be followed for specific emergency procedures can be found in the Manual of Military Air Traffic Management (MMATM)⁵.

Crash Procedures

5. **Tracing Action.** If an Aircraft unexpectedly disappears from radar and there is a loss of radio contact, D&D **should** be informed immediately so that tracing action can be instigated.

6. **Search and Rescue Action.** If an Aircraft crashes or a pilot indicates that they are about to abandon their Aircraft, or it is suspected that either has happened, Controllers **should**:

a. Take immediate action to obtain direction finding bearings and any other pertinent information relating to the Aircraft's last known position, heading and / or FL / altitude.

b. Inform D&D of all pertinent information without delay so that search and rescue activity, co-ordinated by the Joint Rescue Coordination Centre (JRCC), can commence at the earliest opportunity. This does not however prevent the Controller from taking local search action such as requesting local Aircraft operating in the vicinity to conduct a search, but it is essential that D&D are given full details to ensure the JRCC are able to plan and develop the search without duplication of effort.

7. **Crash on or in the vicinity of an Aerodrome.** ATC personnel **should** take immediate crash action, in accordance with (iaw) Local orders.

8. **Crash away from an Aerodrome.** When a crash takes place away from an Aerodrome, the action to be taken will depend on whether the exact location of the crash / forced landing is known or not. When the location is known, Controllers **should** take action iaw Local Orders. When the location is unknown D&D **should** be informed and requested to commence tracing action.

9. **External report of an Aircraft Crash.** If an Aircraft Incident / crash is reported by an outside source, the following information **should** be obtained and passed to D&D:

- a. Originator's full name;
- b. Originator's address;
- c. Originator's phone number;
- d. Exact details of what they witnessed.

³ Not applicable if the Aircraft called up on the VHF / UHF Emergency frequency.

⁴ Aerodrome Emergency Services includes Aerodrome Rescue and Fire Fighting (ARFF) and Aerodrome Emergency Medical Services.

⁵ Refer to the MMATM Chapter 5: Emergency Actions and Procedures.

**Acceptable
Means of
Compliance
3311(1)**

10. **Crash or Incident Narrative.** To ensure vital information is not lost and to assist in any subsequent investigation, personnel directly involved with the crash / Incident **should** ensure all relevant details and any actions taken are accurately recorded in the Air Traffic Watch Log (RAF F6658).
11. **Meteorological (Met) Crash Reports.** When a crash takes place on, or in the vicinity of, an Aerodrome, ATC **should** inform the duty Met Officer without delay requesting a crash actual report to be produced and ATC **should** record the report in the Air Traffic Watch Log (RAF F6658).
12. **Aerodrome Inspection after Crash.** Following any required post crash management activity and when authorized to do so, an inspection of the crash area **should** be made iaw RA 3264⁶ prior to the recommencement of flying, to ensure that any Foreign Object Debris has been recovered and the relevant surfaces of the Movement Area are fit for use.
13. **Information Requests.** Personnel **should not** make a statement, offer any information, or give answers to any questions regarding an Aircraft crash / Incident to unauthorized personnel. The dissemination of any information regarding an Aircraft crash / Incident **should** be restricted to authorized personnel / agencies to whom the original crash message was passed. Any additional inquiries **should** be referred to the relevant individual defined in Local Orders.

**Guidance
Material
3311(1)****Aircraft Emergency and Crash Procedures**

14. The circumstances of each Aircraft emergency can vary to such an extent that detailed instructions cannot be given for every situation; therefore Controllers will use their own judgement when handling an emergency / crash situation.
15. To assist the Controller in ensuring that all pertinent information has been retrieved when handling an abnormal or emergency situation, the use of a checklist detailing what information and follow on actions are required is strongly recommended.

⁶ Refer to RA 3264 – Aerodrome Inspections.

Intentionally Blank for Print Pagination

► This RA has been substantially re-written; for clarity no change marks are presented – please read RA in its entirety ◀

RA 3312 – Overdue Action by Air Traffic Control

Rationale

An Aircraft that has failed to arrive at an Aerodrome or has not established Radio Telephony (RT) communication by a pre-notified time, may have experienced an emergency that requires immediate assistance. Any delay in Air Traffic Control (ATC) taking the appropriate action could increase the Risk to Life. ATC personnel are therefore to understand their responsibilities and actions when carrying out overdue action.

Contents

3312(1): Overdue Action by Air Traffic Control

Regulation

3312(1)

Overdue Action by Air Traffic Control

3312(1) In the event that an Aircraft becomes overdue, ATC personnel **shall** initiate overdue action.

Acceptable Means of Compliance

3312(1)

Overdue Action by Air Traffic Control

1. An Aircraft **should** be considered overdue when the following circumstances exist:
 - a. **Fixed Wing Aircraft.** Failure to arrive or not in RT communication with the intended destination / Squadron Operations at either:
 - (1) Estimated Time of Arrival (ETA) radar entry or other specified terminal calling point; or
 - (2) ETA overhead; or
 - (3) ETA landing.
 - b. **Rotary Wing Aircraft.** Failure to arrive or not in RT communication with the intended destination / Squadron Operations at either:
 - (1) ETA landing; or
 - (2) End of notified endurance.
2. If an Aircraft becomes overdue, ATC **should** pass all relevant details to:
 - a. The Distress & Diversion Cell.
 - b. Appropriate unit personnel in accordance with Local / Unit Orders.
3. Additionally, Controllers **should** initiate overdue action if they have any doubt regarding the Safety of an Aircraft.

Guidance Material

3312(1)

Overdue Action by Air Traffic Control

4. Subject to Aircraft endurance and activity, the Aviation Duty Holder or Accountable Manager (Military Flying) of military rotary wing Aircraft may consider implementing operation normal procedures¹. Where this is applicable, they are to be included within local flying and ATC orders.

¹ Refer to CAP 493 – Manual of Air Traffic Services – Part 1.

Intentionally Blank for Print Pagination

RA 3313 - Air System Diversions

Rationale

Diversions may be required in the event that an Air System is unable to reach its intended destination or an Aerodrome is unable to accept an Air System.

Contents

3313(1): Air System Diversions

Regulation 3313(1)

Air System Diversions

3313(1) Air System diversions **shall** only be initiated by authorized personnel.

Acceptable Means of Compliance 3313(1)

Air System Diversions

1. Diversions **should** only be originated by:
 - a. The Air System Operating Authority.
 - b. Air Traffic Control (ATC).
 - c. The Air System Commander.
2. **Diversions Grades.** The person ordering a diversion **should** ensure that the Commander is informed of the grade of, and the reason for, the diversion.
3. **Grade 1 Diversion.** A Grade 1 diversion is mandatory and **should** only be originated by the Air System Operating Authority. It can be passed to the Commander either through ATC or on the channels of communication of the Air System operating authority. If the Commander considers that ►they◄ cannot comply with the instructions originated, ►they◄ **should** inform the appropriate authority of ►their◄ reasons and indicate ►their◄ intentions or request other instructions.
4. **Grade 2 Diversion.** A Grade 2 diversion is advisory and **should** be originated by the Air System Operating Authority or by ATC. When originated by ATC personnel they **should**, where possible, obtain the approval of the Air System Operating Authority. Where it is not possible to obtain authority from the Operating Authority, ATC **should** inform the Air System operating authority at the earliest opportunity. A Commander who decides to continue to ►their◄ original destination after receiving a Grade 2 diversion **should** inform the Air System Operating Authority, through ATC, of ►their◄ intentions.

Guidance Material 3313(1)

Air System Diversions

5. **Diverting Officers.** In deciding whether a diversion Aerodrome is suitable, the officer ordering the diversion may consider the following:
 - a. The range and endurance of the Air System.
 - b. The experience and qualifications of the crew.
 - c. The weather.
 - d. Radio and radar aids serviceable in the Air System and at the diversion Aerodrome.
 - e. The Air System requirements, eg the landing distance and servicing facilities.
 - f. The administrative facilities at the diversion Aerodrome.
6. **Commander.** Air System Commanders requesting assistance in seeking a diversion are required to pass the following:
 - a. Own callsign and identity.
 - b. Position.

**Guidance
Material
3313(1)**

- c. Original destination.
 - d. Reason for request.
 - e. Endurance.
 - f. Load Classification Group of the Air System.
7. In the event of a Grade 2 diversion, a Commander will only continue to ► **their** ◀ original destination if, in the event of ► **their** ◀ attempt to land at the Aerodrome being unsuccessful, ► **they** ◀ will subsequently be able to reach the diversion Aerodrome with enough fuel to ensure a safe landing in the event of a missed instrument approach.
8. **Procedures at an Air Traffic Control Radar Unit (ATCRU) or Control and Reporting Centre (CRC).** When Air System diversion action is necessary the controller at an ATCRU or CRC ► **will** ◀:
- a. Pass the appropriate type of diversion message to the Commander of the Air System.
 - b. Inform Distress & Diversion (D&D).
 - c. Pass any necessary instructions or appropriate advice to the Air System Commander.
 - d. Inform the Air System operating authority of action taken.
9. **Procedures at an Aerodrome.** Procedures at Aerodromes are as follows:
- a. When the need for diversion is likely to arise for any other reason, an ATC officer at an aerodrome ► **will** ◀ maintain the closest possible liaison with:
 - (1) The Air System operating authority.
 - (2) Pre-selected local diversion aerodrome.
 - (3) D&D.
 - (4) The ATCRU controller, if appropriate.
 - (5) Relevant CRC if appropriate.
 - b. ► **They could** ◀ pass as often as ► **they** ◀ consider necessary the latest information on aerodrome conditions in order that diversions from and to ► **their** ◀ airfield may be anticipated. ► **They are** ◀ also to ensure that D&D is informed whenever ► **their** ◀ aerodrome is active outside the opening hours promulgated in FLIPs. When an Air System diversion is necessary the Supervisor or DATCO (RN) / ATCO IC (RAF) ► **will** ◀ take the following action:
 - (1) Inform D&D.
 - (2) Obtain all necessary instructions for the Commander of the Air System, which will include the obtaining of clearance from controlled airspace authorities, if required.
 - (3) Pass the appropriate type of diversion message to the Commander of the Air System.
 - (4) Inform the Air System operating authority of action taken.

RA 3500 - Aerodrome Design and Safeguarding

Rationale

An Aerodrome is intended to be a safe place for ► **Aircraft** ◀ to operate from. Many factors need to be considered when constructing an Aerodrome. Standards that are not met could ► **increase Aviation Risk to Life (RtL)** and ◀ be instrumental in ► **Aircraft Accident** or ◀ damage. A safe operating environment, at MOD Aerodromes, can be provided by adherence to design standards and safeguarding processes¹.

Contents

3500(1): Aerodrome Design and Safeguarding

Regulation 3500(1)

Aerodrome Design and Safeguarding

3500(1) Heads of Establishments (HoEs) and Aviation Duty Holder-Facing organizations (ADH-Facing organizations) **shall** ensure that Military Aerodrome Design and Safeguarding is in accordance with (iaw) criteria specified within RA 3501 - 3599².

Acceptable Means of Compliance 3500(1)

Aerodrome Design and Safeguarding

1. The Regulations contained within RA 3501 - 3599 **should** be applied to the new construction, modification and restoration of facilities at MOD MRP regulated Aerodromes in the UK and overseas.
2. 'Modification' **should** include the use of Aerodrome facilities for purposes other than their intended use at construction, such as the use of a runway for precision approaches that was designed to support non-instrument approaches only or use of Aerodrome surfaces by Aircraft larger or heavier than those for which the surfaces were constructed³.
3. Existing facilities that do not comply with the Regulations contained within RA 3501 - 3599 may present Aviation Safety Hazards. Therefore each non-compliance **should** be logged in the Aerodrome ► **Operators** ◀ Hazard Log (AOHL) and thereby communicated to relevant ADHs through the mechanism of the Defence Aerodrome Manual and managed through the Air Safety Management System⁴.
4. The following **should** be included in assurance certification of major and minor work, where appropriate, to be presented at handover. A copy of the documentation in a suitable electronic format **should** be provided to the MOD Specialist:
 - a. Aeronautical Ground Lighting (AGL) System Design and Installation Compliance Certificate.
 - b. In situ AGL Photometric Test Certificate of Compliance⁵.
 - c. Apron Floodlighting Photometric Test Certificate of Compliance.
 - d. Certificate of Compliance for provision of Secondary Power Supplies⁶.
 - e. Precision Approach Path Indicator (PAPI) Flight Check Form⁷.
 - f. Modular Control System Functional Test Certificate⁸.

¹ ► Refer to RA 1010(1): Head of Establishment – Classification Tier of Site, Establishment, Base or Building to assist with MAA Regulatory Publications (MRP) compliance. ◀

² Refer to RA 3500 to 3599: Aerodrome Design and Safeguarding.

³ Non-exhaustive.

⁴ Refer to RA 1200 - Air Safety Management and the Manual of Air Safety (MAS).

⁵ New, refurbished or modified installations where more than 25% of the system has been changed. All Runway Services and Taxiway Centreline only.

⁶ Determined by Approach Category and Take-off Runway Visual Range (RVR).

⁷ Where bases may have been affected or a PAPI unit has been damaged or removed and replaced.

⁸ Full system check required after any work is undertaken. Compliance with Defence Infrastructure Organization (DIO) Policy Instruction 19/2006 is mandatory.

**Acceptable
Means of
Compliance
3500(1)**

- g. Insulation Resistance Test Results⁹.
- h. "As Built" Drawings (including final surface levels).
- i. Updated Airfield Lighting Schedule.
- j. AGL Equipment Warranty.
- k. Friction test results post completion.
- l. Friction Test Certificate.
- m. Operation and Maintenance manuals.
- n. Pavement Classification Number (PCN) / Aircraft Classification Number (ACN) calculations.
- o. Core logs and test pit data.
- p. All test results for the project.
- q. Details of asphalt and concrete mix design(s).
- r. Updated Annex C1 and C2 from the latest Biennial Inspection Airfield Maintenance Inspection Report (AMIR).

**Guidance
Material
3500(1)**

Aerodrome Design and Safeguarding

5. For the avoidance of doubt, there is no requirement for facilities to be modified solely in order to meet new standards introduced within the RA 3500 series, as routine or exceptional construction, restoration or Maintenance processes will enable these standards to be met in due course.
6. For existing legacy Aerodrome Design and Safeguarding non-compliances, there is also no requirement to apply for Alternative Acceptable Means of Compliance (AAMC), Waivers or Exemptions (AWE).
7. Where an existing non-compliance is managed through the AOHL, it is recommended that they are separated for clarity from other Hazards in the AOHL by means of an appropriate naming convention.
8. International Civil Aviation Organization (ICAO), Civil Aviation Authority (CAA) and North Atlantic Treaty Organization (NATO) publications may be consulted where they supplement RA 3501 - 3599 standards. If uncertainty exists, the MAA need to be consulted.
9. Procurement of airfield infrastructure services, whether new works or Maintenance, is the responsibility of the Defence Infrastructure Organization (DIO), less on deployed operational bases in Military Works Areas where the military is responsible, usually through the Royal Engineers.
10. The following may be consulted in support of the requirements of RA 3501 - 3599:
 - a. AP 100B-01 RAF Engineering Policy.
 - b. DAP 113A-0201-1 Earthing of Aircraft and General Support Equipment.
 - c. DAP 119J-1405-12 Rotary Hydraulic Arresting Gear Mk 1.
 - d. AP 119J-0100-1 Snow Clearance and Ice Control of Airfields.
 - e. Manual of Military Air Traffic Management (MMATM).
 - f. JSP 375 Management of Health and Safety in Defence.
 - g. JSP 317 Defence Fuels Policy, Organization and Safety Regulations.
 - h. DAP 119J-1400-1 Aircraft Arresting System, Operational Data and Aircraft Clearances.

⁹ Results to comply with DIO Policy Instruction 29/2005 Annex B.

**Guidance
Material
3500(1)**

- i. ICAO Standards and Recommended Practices Annex 14 Volume 1 Aerodrome Design and Operations¹⁰.
- j. ICAO Standards and Recommended Practices Annex 14 Volume 2 Heliports.
- k. ICAO Aerodrome Design Manual (Doc 9157).
- l. ICAO Aerodrome Services Manual (Doc 9137).
- m. ICAO Manual of Runway Visual Range Observing and Reporting Practices (Doc 9328).
- n. CAP 393 The Air Navigation Order.
- o. CAP 168 Licensing of Aerodromes.
- p. CAP 642 Airside Safety Management.
- q. EASA CS-ADR-DSN Aerodromes Design.
- r. CAP 1168 Guidance Material for Organizations, Operations and Design Requirements for Aerodromes.
- s. **► DIO Technical Standard: VA 01:2022 – Aerodrome Design Standard Visual Aids. ◀**

11. The NATO Standardization Agreements (STANAGs) implemented by RA 3501 - 3599 are shown in Figure 1:

Figure 1. NATO STANAGs.

| STANAG Number | Title | Edition | Status |
|---------------|--|---------|------------------------------------|
| 3158 | Day Marking of Airfield Runways and Taxiways | 9 | Ratified |
| 3316 | Airfield Lighting | 10 | Ratified with Reservations |
| 3346 | Marking and Lighting of Airfield Obstructions | 7 | Ratified |
| 3534 | Airfield Lighting, Marking and Tone Down Systems for Non-Permanent / Deployed Operations | 7 | Ratified with Reservations * |
| 3619 | Helipad Marking and Lighting | 5 | Ratified with Reservations |
| 3634 | Runway Friction and Braking Conditions | 4 | Ratified |
| 3697 | Airfield Aircraft Arresting Systems | 5 | Ratified |
| 3711 | Airfield Marking and Lighting Colour Standards | 3 | Ratified * |
| 7114 | Helipad Clearance Plane Requirements | 1 | Ratified for Future Implementation |
| 7131 | Aircraft Classification Number (ACN) / Pavement Classification Number (PCN) – AEP 46(B) | 3 | Ratified |
| 7134 | Control of Lighting at Airfields During NVG Operations | 1 | Ratified |
| 7174 | Airfield Clearance Planes | 1 | Ratified with Reservations |
| 7181 | NATO Standard Method for Airfield Pavement Condition Index (PCI) Surveys – AEP-56 | 1 | Ratified for Future Implementation |

¹⁰ Accounts to access ICAO documentation are available to MOD employees and contractors from <http://portallogin.icao.int/>.

**Guidance
Material
3500(1)**

* Implementing Document is the STANAG.

12. Guidance may be sought from MOD specialists as per Figure 2:

Figure 2. MOD Specialists.

| Subject | Address | Contact Details |
|--|---|---|
| Regulatory Guidance: Government Aerodromes | MAA Reg ATM2 ADInfra, Juniper 1 Wg 4 #5104, MOD Abbey Wood (North) Bristol, BS34 8JH | Tel: 0306 7984231 Email: DSA-MAA-Reg-ATM2-AdInfra@mod.gov.uk |
| Royal Air Force (Safeguarding) | BM Safeguarding SO2 DIO, Kingston Road, Sutton Coldfield, B75 7RL | Tel: 0121 3312237 Email: Air-11GpBM-SafeguardingSO2@mod.gov.uk |
| Royal Air Force (Aerodromes) | BM A35 Terminal SO2, Third Floor, Hurricane Block, Air Command, RAF High Wycombe, NAPHILL HP14 4UE | Tel: 0306 7701071 Email: Air-11Gp-SpBM-A35AirfieldsSO2@mod.gov.uk |
| Joint Helicopter Command (JHC) | SO2 JHC SA Safety Policy, HQ JHC, HQ Land Forces, Marlborough Lines, Monxton Road, Andover, SP11 8HT | Tel: 01264 381131 Email: JHC-SafetyPolicy-SO2@mod.gov.uk |
| Royal Navy | NCHQ CSAV SO2 ATC HMS Excellent Whale Island, Portsmouth Hampshire PO2 8ER | Tel: 02392 625748 Email: NAVYCSAV-ATCSO2@mod.gov.uk |
| 12 (Force Sp) Engr Gp | SO1 12 (Force Sp) Engr Gp Building 408, RAF Wittering, Peterborough, PE8 6HB | Tel: 01780 417729 Email: 12ENGGP-DCOMD@mod.gov.uk |
| PJHQ | PJHQ CESO, PJHQ, Northwood HQ, Sandy Lane, NORTHWOOD, Middlesex, HA6 3HP | Tel: 01923 955043 Email: PJHQ-J3-CESO@mod.gov.uk |
| Safeguarding | DIO, Safeguarding, Safeguarding Officer (Statutory & Offshore), Kingston Road, Sutton Coldfield, West Midlands, B75 7RL | Email: DIO-Safeguarding-Statutory@mod.gov.uk or DIO-Safeguarding-Wind@mod.gov.uk |
| Pavements | DIO, Technical Services, Technical Authority (Pavements) Engineering and Construction, , Kingston Road, Sutton Coldfield, West Midlands, B75 7RL | Email: DIOTS-EngAPStdsAH@mod.gov.uk |
| Visual Aids | DIO, Technical Services, Technical Authority (AGL) Engineering and Construction, Electrical Infrastructure, Kingston Road, Sutton Coldfield, West Midlands, B75 7RL | Email: DIOTS-EngElecAH@mod.gov.uk |
| Compass Calibration Bases | QinetiQ, Land Magnetic Facilities MOD Portland Bill, Portland, Dorset, DT5 2JT | Tel: 01305 862022 01305 862000 |

**Guidance
Material
3500(1)**

13. Responsibilities for military Aerodrome design, standards, inspections and surveys are as per Figure 3:

Figure 3. Organizational Responsibilities.

| Responsible Organization / Responsibility | Staff Inspection | Friction Surveys | | | Maintenance Inspections | Measured Height Surveys | Works (Major & Minor) | Remarks |
|---|------------------|------------------|------------|---------|-------------------------|-------------------------|-----------------------|---|
| | | Classification | Monitoring | Special | | | | |
| APPROPRIATE MILITARY AUTHORITIES | | | | | | | | |
| Assist Operations Staffs to set minimum standards | • | • | • | • | • | • | • | |
| Confirm requirement for special surveys related to flight safety | | | | • | • | • | | |
| Approval Authority for proposed deviation from Regulations | • | • | • | • | • | • | • | |
| Promulgate Staff Inspection Programme | • | | | | | | | |
| Approval Authority for friction measurement machines | | • | • | • | | | | With MOD Specialists' advice |
| TOP LEVEL BUDGET (TLB) REPRESENTATIVES | | | | | | | | |
| Set operational and design requirements | | | | | | | • | Seek MOD Specialists' advice |
| Sponsor, fund and programme any major projects / safeguarding | | • | • | • | • | • | • | |
| Agree and promulgate the Inspection / Survey programme annually | | • | • | • | • | • | | From MOD Specialists' input |
| Identify safeguarding requirements | | | | | • | • | • | |
| DEFENCE EQUIPMENT AND SUPPORT | | | | | | | | |
| Equipment Manager for in-service friction measuring devices. | | • | • | • | | | | Including those held by Specialist Team Royal Engineers (STRE) (Air Sp) when Authorized |
| Fund spares and calibration of in-service approved friction classification equipment held | | • | • | • | | | | Currently Mu-Meter Mk V |
| MOD SPECIALISTS | | | | | | | | |
| Policy on construction materials and equipment (ie performance, characteristics, testing, etc.) | | • | • | • | • | | • | |
| Maintain Inspection / Survey databases for MOD Aerodromes | | • | | • | • | • | | |

| | | | | | | | | | | |
|---|---|----|---|---|---|----|---|---|--|------------------------------|
| Guidance Material 3500(1) | Approval Authority for Inspection / Survey procedures and agencies | | • | • | • | • | • | | | |
| | Draft / advise on Inspection / Survey Programmes | | • | | • | • | • | | Annually | |
| | Arrange contract support to Inspections / Surveys | | • | | • | • | • | | | |
| | DIO Safeguarding produce Safeguarding plans | | | | | • | • | • | | |
| | DIO implement the Safeguarding process | | | | | • | • | • | | |
| | STRE (Air Sp) | | | | | | | | | |
| | Maintain and operate in-service friction measuring devices | | • | | • | | | | | When issued and authorized |
| | Carry out operational Inspections / Surveys at Forward Operating Base (FOB) | | • | | • | • | • | | | |
| | STATIONS | | | | | | | | | |
| | Set operational and design requirements | | | | | | | | • | Seek MOD Specialists' advice |
| Conduct Friction Monitoring Surveys | | | | • | | | | | Stns without Mu-Meters to request surveys as required | |
| Fund Inspections / Surveys | | • | • | • | • | • | | | Except at handover of major projects when project pays | |
| Request surveys as required | | | | | • | | | | | |
| Conduct periodic inspections | | | | | • | | | | iaw the MMATM | |
| Frequency of Inspections / Surveys (years) | 1 | 4c | a | a | 2 | 1d | | | | |
| <p>^a As required</p> <p>^b Statutory</p> <p>^c Annually when Friction Level is below Maintenance Planning Level (MPL)</p> <p>^d Measured Height Survey annually, or at frequencies as determined iaw with CAP 232¹¹ or CAP 1732¹² as applicable.</p> | | | | | | | | | | |

¹¹ Refer to CAP 232 – Aerodrome Survey Information.

¹² Refer to CAP 1732 – Aerodrome Survey Guidance.

RA 3510 - Permanent Fixed Wing Aerodrome - Reference Information

Rationale

A Common Reference System, reference codes and aerodrome data are required to inform operators of the key information about the aerodrome. The accuracy and integrity of aeronautical data is essential to support safe operations in and around the aerodrome.

Contents

3510(1): Common Reference System

3510(2): Reference Codes

3510(3): Aerodrome Data

Regulation

3510(1)

Common Reference System

3510(1) Heads of Establishments (HoEs) and Aviation Duty Holder (ADH)-Facing organizations **shall** use a Common Reference System for horizontal, vertical and temporal measurements for an aerodrome.

Acceptable Means of Compliance 3510(1)

Common Reference System

1. For a Horizontal reference system, the World Geodetic System - 1984 (WGS-84) **should** be used. Reported aeronautical geographical coordinates (indicating latitude and longitude) **should** be expressed in terms of the WGS-84 geodetic reference datum.
2. For a Vertical reference system, Mean Sea Level **should** be used as the vertical reference system.
3. For a Temporal reference system, the Gregorian calendar and Coordinated Universal Time (UTC) **should** be used.

Guidance Material 3510(1)

Common Reference System

Civil Equivalence.

4. This regulation is in line with International Civil Aviation Organization (ICAO) Annex 14 Vol I Section 1.3.

Regulation 3510(2)

Reference Codes

3510(2) HoEs and ADH-Facing organizations **shall** determine an aerodrome reference code in accordance with (iaw) the critical characteristics of the Air System(s) for which an aerodrome facility is intended.

Acceptable Means of Compliance 3510(2)

Reference Codes

5. The aerodrome reference code numbers and letters **should** conform with the requirements in Table 1.
6. The code number for element 1 **should** be determined from Table 1 by selecting the code number corresponding to the highest value of the Air System reference field lengths of the Air System(s) for which the runway is intended.
7. The code letter for element 2 **should** be determined from Table 1 by selecting the code letter which corresponds to the greatest wingspan of the Air System(s) for which the facility is intended.

**Acceptable
Means of
Compliance
3510(2)**

Table 1. Aerodrome reference code

| Code element 1 | |
|----------------|---------------------------------------|
| Code number | Aeroplane reference field length |
| 1 | Less than 800 m |
| 2 | 800 m up to but not including 1200 m |
| 3 | 1200 m up to but not including 1800 m |
| 4 | 1800 m and over |
| Code element 2 | |
| Code letter | Wingspan |
| A | Up to but not including 15 m |
| B | 15 m up to but not including 24 m |
| C | 24 m up to but not including 36 m |
| D | 36 m up to but not including 52 m |
| E | 52 m up to but not including 65 m |
| F | 65 m up to but not including 80 m |

Note - Guidance on planning for Air Systems with wingspans greater than 80 m is given in the ICAO Aerodrome Design Manual (ICAO Doc 9157), Parts 1 and 2.

**Guidance
Material
3510(2)**

Reference Codes

8. In addition to the reference codes, other Air System characteristics, such as Air System length and tail height, may have an impact on the design of an aerodrome. Some characteristics such as wingspan or wheel span directly impact one element of the code but not the other. Aerodrome design has to consider all the relationships between Air System characteristics, the aerodrome and the characteristics of the aerodrome infrastructure.

9. In practice an Air System exhibiting one or more of the most onerous characteristics is often referred to as the critical Air System for the purpose of Aerodrome design.

10. It is recognized that when planning and designing new aerodrome facilities (or reconfiguring existing areas of an aerodrome), not all areas of the aerodrome may need to adhere to the same Aerodrome Reference Code as determined by the critical Air System. Therefore, elements of the aerodrome infrastructure may be designated with an appropriate code letter for its dimensions and Air System use and communicated to relevant ADHs through the mechanism of the Defence Aerodrome Manual and appropriate Aeronautical Information Publication.

11. 

Civil Equivalence.

12. This regulation is in line with ICAO Annex 14 Vol I para 1.6.1-1.6.4.

**Regulation
3510(3)**

Aerodrome Data

3510(3) HoEs and ADH-Facing organizations **shall** establish and report the following attributes to the aeronautical information services organization: Aerodrome Reference Point; Aerodrome and Runway Elevations; Aerodrome Reference Temperature; Aerodrome Dimensions; Pavement Strength; Declared Distances; Rescue and Fire Fighting Services

**Regulation
3510(3)**

category; and Visual Approach Slope Indicator Systems details.

**Acceptable
Means of
Compliance
3510(3)****Aerodrome Data**

13. The Aerodrome Reference point **should** be established for an aerodrome, be located near the initial or planned geometric centre of the aerodrome and **should** normally remain where first established and be measured and reported to the aeronautical information services authority in degrees, minutes and seconds.
14. The Aerodrome and Runway Elevations **should** also include the geoid undulation at the aerodrome elevation, be measured and reported to the aeronautical information services authority to the accuracy of one-half metre or foot and, for a Precision Approach runway, also include the geoid undulation of the threshold, the elevation of the runway end and the highest elevation of the touchdown zone and **should** be measured and reported to the accuracy of one-quarter metre or foot.
15. The Aerodrome Reference Temperature **should** be determined for an aerodrome in degrees Celsius and be the monthly mean of the daily maximum temperatures for the hottest month of the year (the hottest month being that which has the highest monthly mean temperature). This temperature **should** be averaged over a period of years.
16. The following Aerodrome Dimensions and related information **should** be reported:
- a. For a runway:
 - (1) True Bearing (nearest one-hundredth of a degree).
 - (2) Designation Number.
 - (3) Length, width and displaced threshold location to nearest metre or foot.
 - (4) Slope, surface type and type of runway.
 - (5) For a precision approach runway (Cat I), the existence of an Obstacle Free Zone when provided.
 - b. For strips, runway end safety areas and stopways:
 - (1) Length and width to the nearest metre or foot.
 - (2) Surface type.
 - c. For taxiways:
 - (1) Designation.
 - (2) Width.
 - (3) Surface type.
 - d. For aprons:
 - (1) Surface type.
 - (2) Air System stands.
 - e. The boundaries of the Air Traffic Control (ATC) service:
 - f. For clearways:
 - (1) Length to the nearest metre or foot.
 - (2) Ground profiles.
 - g. For installed lighting:
 - (1) Visual approach aids.
 - (2) Runway, taxiway and apron lighting including guidance and control aids.
 - (3) Operating Minima.

**Acceptable
Means of
Compliance
3510(3)**

- (4) Minimum Eye Height(s) over the Threshold (MEHT) of the on-slope Signals(s) MEHT.
- (5) Visual and non-visual Glide Path (GP) and Touchdown Point elevation and distance with respect to Threshold location.
- h. For airfield marking and mandatory signs:
- (1) Runway, taxiway and apron markings and signs.
 - (2) Runway-holding positions and stop bars.
 - (3) Location and designation of standard taxi-routes.
- i. For an Instrument Landing System (ILS), distances to the nearest metre or foot of localizer and GP elements of the ILS in relation to the runway extremities which they serve.
- j. Pavement strength.
17. The following geographical coordinates **should** be measured and reported to the aeronautical information services authority in degrees, minutes, seconds and hundredths of seconds:
- a. Each threshold;
 - b. Appropriate taxiway centre-line points;
 - c. Each Air System stand;
 - d. Obstacles within the aerodrome boundary.
18. The following distances to the nearest metre or foot **should** be calculated and declared for an aerodrome:
- a. Take-off run available (TORA).
 - b. Take-off distance available (TODA).
 - c. Accelerate-stop distance available (ASDA).
 - d. Landing distance available (LDA).
19. Information concerning the level of protection provided at an aerodrome for Aerodrome Rescue and Firefighting (ARFF) services **should** be made available. The level of protection normally available at an aerodrome **should** be expressed in terms of the category of the rescue and firefighting services as described in DSA02 DFRS¹ and in accordance with the types and amounts of extinguishing agents normally available at the aerodrome.
20. The following information concerning a visual approach slope indicator system installation **should** be made available:
- a. Associated runway designation number.
 - b. The type of system according to RA 3515². For a Precision Approach Path Indicators (PAPI) or an Abbreviated Precision Approach Path Indicators (APAPI) installation, the side of the runway on which the lights are installed **should** be given.
 - c. Where the axis of the system is not parallel to the runway centre-line, the angle of displacement and the direction of displacement, ie left or right, **should** be indicated.
 - d. For a PAPI and an APAPI the Nominal approach angle(s) **should** be angle $(B + C) \div 2$ and $(A + B) \div 2$, respectively as in Figure 1; and
 - e. For MEHT of the on-slope signals for a PAPI this **should** be the setting angle of the third unit from the runway minus 2 minutes, ie angle B minus 2 minutes, and for an APAPI this **should** be the setting angle of the unit farther from the runway minus 2 minutes, ie angle A minus 2 minutes as in Figure 1.

¹ Refer to DSA02 DFRS – Defence Aerodrome Rescue and Firefighting Regulations.

² Refer to RA 3515 – Permanent Fixed Wing Aerodrome - Lighting.

Acceptable Means of Compliance 3510(3)

Figure 1. Light beams and angle of elevation setting of PAPI and Abbreviated PAPI

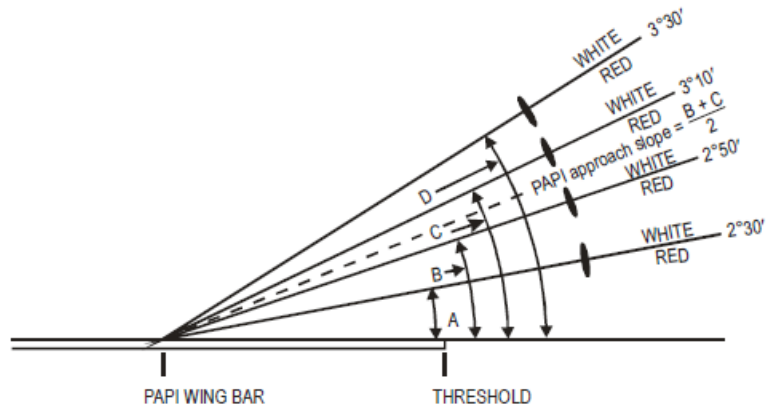

The height of the pilot's eye above the aircraft's ILS glide path/MLS antenna varies with the type of aeroplane and approach attitude. Harmonization of the PAPI signal and ILS glide path and/or MLS minimum glide path to a point closer to the threshold may be achieved by increasing the on-course sector from 20' to 30'. The setting angles for a 3° glide slope would then be 2°25', 2°45', 3°15' and 3°35'.

A — 3° PAPI ILLUSTRATED

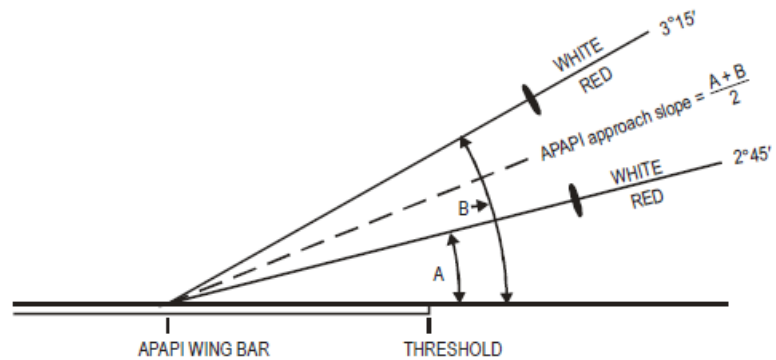

B — 3° APAPI ILLUSTRATED

21. Aeronautical Data Quality (ADQ) requirements **should** be in accordance with ICAO Annex 14, Volume I, Appendix 5.

Guidance Material 3510(3)

Aerodrome Data Civil Equivalence.

22. This regulation is in line with ICAO Annex 14 Vol I para 2.2 – 2.12.

Intentionally Blank for Print Pagination

RA 3511 - Permanent Fixed Wing Aerodrome - Physical Characteristics

Rationale

The physical characteristics of an aerodrome are defined to reduce the Risk to Life (RtL) associated with an Air System transiting over, when taking-off and landing or when taxiing around the aerodrome. The characteristics are also designed to reduce RtL during an incident or accident scenario; to enable safe use by rescue and firefighting vehicles; when loading, and unloading passengers, crew and cargo; and when servicing Air Systems.

Contents

- 3511(1): Pavement - Characteristics**
- 3511(2): Runway - Number, Siting and Orientation**
- 3511(3): Runway - Dimensions**
- 3511(4): Runway - Characteristics**
- 3511(5): Runway - Runway-End Safety Areas**
- 3511(6): Taxiway - Characteristics**
- 3511(7): Aprons**

Regulation

3511(1)

Pavement - Characteristics

3511(1) Heads of Establishments (HoEs) and Aviation Duty Holder-Facing Organizations (ADH-Facing Organizations) **shall** ensure that the Pavements at their aerodrome are sufficient, in terms of Bearing strength, Overload operations, friction levels and surface evenness, to cope with the continual use of the Air System for which the aerodrome is intended to serve.

Acceptable Means of Compliance 3511(1)

Pavement – Characteristics

Bearing Strength.

1. The bearing strength of a pavement, including the runway, intended for Air Systems of All Up Mass (AUM) greater than 5700 kg **should** be made available using the Aircraft Classification Number - Pavement Classification Number (ACN-PCN) method by reporting all the following information:
 - a. The Pavement Classification Number (PCN);
 - b. Pavement type for ACN-PCN determination;
 - c. Subgrade strength category;
 - d. Maximum allowable tyre pressure category or maximum allowable tyre pressure value; and
 - e. Evaluation method.
2. For the purposes of determining the Aircraft Classification Number (ACN), the behaviour of a pavement **should** be classified as equivalent to a rigid or flexible construction.
3. Information on pavement type for ACN-PCN determination, subgrade strength category, maximum allowable tyre pressure category and evaluation method **should** be reported using the codes from Table 1.
4. The bearing strength of a pavement intended for Air Systems of AUM equal to or less than 5700 kg **should** be made available by reporting the following information:
 - a. Maximum allowable Air System mass; and
 - b. Maximum allowable tyre pressure.

Acceptable Means of Compliance 3511(1)

Table 1. PCN Reporting

| Part | Description | Remarks |
|------|------------------------------|---|
| 1 | PCN | ACN max at appropriate subgrade category |
| 2 | Pavement type | Rigid Flexible |
| 3 | Pavement subgrade category | A = High B = Medium C = Low D = Ultra Low |
| 4 | Tyre pressure max authorized | 1.5 MPa (217psi) < W (high) 1.0 MPa (145psi) < X (medium) ≤ 1.5 MPa (217 psi) 0.5 MPa (73 psi) < Y (low) ≤ 1.0 MPa (145 psi) Z (very low) ≤ 0.5 MPa (73 psi) |
| 5 | Pavement design method | T = Technical design or evaluation U = By experience of Air Systems using the pavement |

Overload Operations.

5. Overload operations **should** only be permitted by the Aerodrome Operator having considered the criteria contained in the Defence Infrastructure Organization (DIO) publication 'A Guide to Airfield Pavement Design and Evaluation' (3rd Edn 2011)¹.

Friction Levels.

6. The surface of a taxiway **should** be constructed or resurfaced to provide suitable surface friction characteristics in accordance with (iaw) International Civil Aviation Organization (ICAO) Annex 14 Vol I Attachment A, section 7.

Surface Evenness.

7. Except across the crown of a camber or across drainage channels, the finished surface of the wearing course **should** be of such regularity that, when tested with a 3 m straight-edge placed anywhere in any direction on the surface, there **should** be no deviation greater than 3 mm between the bottom of the straight-edge and the surface of the pavement anywhere along the straight-edge.

8. Maximum surface irregularities **should** be no more than those shown in Table 2.

Table 2. Surface Evenness

| Surface irregularity | Minimum acceptable length of irregularity (m) | | | | | | | | |
|--|---|-----|-----|-----|-----|----|-----|----|----|
| | 3 | 6 | 9 | 12 | 15 | 20 | 30 | 45 | 60 |
| Maximum surface irregularity height (or depth) (cm) | 3 | 3.5 | 4 | 5 | 5.5 | 6 | 6.5 | 8 | 10 |
| Temporary acceptable surface irregularity height (or depth) (cm) | 3.5 | 5.5 | 6.5 | 7.5 | 8 | 9 | 11 | 13 | 15 |

Guidance Material 3511(1)

Pavement – Characteristics

9. Whilst the above considerations are important for all Air System movement areas, they are most critical for runways.

10. Detailed descriptions of the ACN-PCN method are given in the ICAO DOC 9157 Aerodrome Design Manual, Part 3 (2nd Edn 1983) and in the DIO publication 'A Guide to Airfield Pavement Design and Evaluation' (3rd Edn 2011).

11. Subgrade Strength Category Decode:

¹Refer to RA 3500 - Aerodrome Design and Safeguarding for contact details.

**Guidance
Material
3511(1)**

- a. Code A - High Strength: $K = 150 \text{ MN/m}^3$ and representing all K values above 120 MN/m^3 for rigid pavements, and by California Bearing Ratio (CBR) = 15 and representing all CBR values above 13 for flexible pavements.
- b. Code B - Medium Strength: $K = 80 \text{ MN/m}^3$ and representing a range in K of 60 to 120 MN/m^3 for rigid pavements, and by CBR = 10 and representing a range in CBR of 8 to 13 for flexible pavements.
- c. Code C - Low Strength: $K = 40 \text{ MN/m}^3$ and representing a range in K of 25 to 60 MN/m^3 for rigid pavements, and by CBR = 6 and representing a range in CBR of 4 to 8 for flexible pavements.
- d. Code D - Ultra Low Strength: 20 MN/m^3 and representing all K values below 25 MN/m^3 for rigid pavements, and by CBR = 3 and representing all CBR values below 4 for flexible pavements.

12. Unless a pavement is subject to extreme overloading it is unlikely to fail suddenly or catastrophically. Regular overload operations can substantially reduce the design life of the pavement. Advice can be sought from MOD DIO Pavement specialists.

Civil Equivalence.

13. This regulation is in line with ICAO Annex 14 Vol I para 2.6.1 – 2.6.8 and Attachment A.

**Regulation
3511(2)**

Runway - Number, Siting and Orientation

3511(2) HoEs and ADH-Facing Organizations **shall** ensure that the number, siting and orientation of runways are such that the usability factor of the aerodrome is optimised considering that safety **shall not** be compromised.

**Acceptable
Means of
Compliance
3511(2)**

Runway - Number, Siting and Orientation

14. The number, siting and orientation of runways **should** be such that the usability factor of the aerodrome would be not less than 95% for the Air System that the aerodrome is intended to serve.

**Guidance
Material
3511(2)**

Runway - Number, Siting and Orientation

15. Factors affecting the determination of the orientation, siting, and number of runways include:

- a. The wind distribution (to minimise crosswinds liable to affect runways);
 - (1) Wind statistics used for the calculation of the usability factor are normally available in ranges of speed and direction, and the accuracy of the results obtained, depends on the assumed distribution of observations within these ranges.
 - (2) The maximum mean crosswind components for the designed Air System, refer to normal circumstances. There are some factors which may require that a reduction of those maximum values be considered at a particular aerodrome. These include:
 - (a) The wide variations which may exist, in handling characteristics and maximum permissible crosswind components, among diverse types of Air System (including future types).
 - (b) Prevalence and nature of gusts.
 - (c) Prevalence and nature of turbulence.
 - (d) The availability of a secondary runway.
 - (e) The width of runways.

**Guidance
Material
3511(2)**

- (f) The runway surface conditions - water, snow, and ice on the runway materially reduce the allowable crosswind component.
 - (g) The strength of the wind associated with the limiting crosswind component.
- b. The need to facilitate the provision of approaches conforming to the approach surface specifications, ensuring that obstacles in these areas or other factors do not restrict the operation of the Air System for which the runway is intended. This may relate to individual obstacles or local geography (eg high ground).
 - c. The need to minimise interference with areas approved for residential use and other noise-sensitive areas close to the aerodrome.
 - d. The need to avoid the turbulence impacts of buildings on or close to the aerodrome.
 - e. Topography of the aerodrome site, its approaches and surroundings, particularly:
 - (1) Compliance with the Obstacle Limitation Surfaces (OLS).
 - (2) Current and future land use. The orientation and layout may be selected to protect, as far as possible, the particularly sensitive areas, such as residential, school and hospital zones, from the discomfort caused by Air System noise. Detailed information on this topic is provided in the ICAO Doc 9184, Airport Planning Manual, Part 2, Land Use and Environmental Management and in ICAO Doc 9829, Guidance on the Balanced Approach to Aircraft Noise Management;
 - (3) Current and future runway lengths to be provided;
 - (4) Construction costs; and
 - (5) Possibility of installing suitable non-visual and visual aids for approach-to-land.
 - f. Air traffic in the vicinity of the aerodrome, particularly:
 - (1) Proximity of other aerodromes or Air Traffic Service (ATS) routes;
 - (2) Traffic density; and
 - (3) Air Traffic Control (ATC) and missed approach procedures

Civil Equivalence.

16. This regulation is in line with ICAO Annex 14 Vol I Attachment A.

**Regulation
3511(3)**

Runway - Dimensions

- 3511(3) HoEs and ADH-Facing Organizations **shall** ensure that the length of the runway provides declared distances adequate to meet the operational requirements for the Air System(s) which the aerodrome is intended to serve, and that the width is derived according to the aerodrome reference code.

**Acceptable
Means of
Compliance
3511(3)**

Runway - Dimensions

Length.

17. The following distances **should** be calculated to the nearest metre for each runway:
- a. Take-Off Run Available (TORA).
 - b. Take-Off Distance Available (TODA).
 - c. Accelerate-Stop Distance Available (ASDA).
 - d. Landing Distance Available (LDA).

Acceptable Means of Compliance 3511(3)

18. The length of the runway **should** be measured from the start of the runway pavement or where a transverse stripe marking is provided to indicate threshold displacement, at the outer edge of the transverse stripe across the runway
19. 150 m at each end of each runway **should** be of rigid construction to combat the effects of jet engine efflux.

Width.

20. The width of a runway **should** be not less than the appropriate dimension specified in the Table 3.
21. The width of the runway **should** be measured at the outside edge of the runway side stripe marking where provided, or the edge of the runway.

Table 3. Runway Width

| Code number | Code Letter | | | | | |
|----------------|-------------|------|------|------|------|------|
| | A | B | C | D | E | F |
| 1 ^a | 18 m | 18 m | 23 m | - | - | - |
| 2 ^a | 23 m | 23 m | 30 m | - | - | - |
| 3 | 30 m | 30 m | 30 m | 45 m | - | - |
| 4 | - | - | 45 m | 45 m | 45 m | 60 m |

a. The width of a precision approach runway **should not** be less than 30 m where the code number is 1 or 2

Note 1 – The combinations of code numbers and letters for which widths are specified have been developed for typical Air System characteristics.

Note 2 – Factors affecting runway width are given in the Aerodrome Design Manual (ICAO Doc 9157), Part 1

Guidance Material 3511(3)

Runway - Dimensions
Civil Equivalence.

22. This regulation is in line with ICAO Annex 14 Vol I para 3.1.7 – 3.1.10.

Regulation 3511(4)

Runway - Characteristics

- 3511(4) HoEs and ADH-Facing Organizations **shall** ensure that the Runway physical characteristics are designed to enable the stabilised and safe use of the runway by the Air System for which the aerodrome is intended.

Acceptable Means of Compliance 3511(4)

Runway - Characteristics
Longitudinal Slope.

23. The longitudinal slope is computed by dividing the difference between the maximum and minimum elevation along the runway centre-line by the runway length and **should not** exceed:
- a. 1% where the code number is 3 or greater.
 - b. 2% where the code number is 1 or 2.
24. Along no portion of a runway **should** the longitudinal slope exceed:
- a. 1.25% where the code number is 4 or greater, except that for the first and last quarter of the length of the runway where the longitudinal slope **should not** exceed 0.8%;

**Acceptable
Means of
Compliance
3511(4)**

- b. 1.5% where the code number is 3, except that for the first and last quarter of the length of a precision approach runway category II or III where the longitudinal slope **should not** exceed 0.8%; and
- c. 2% where the code number is 1 or 2.

25. Where slope changes cannot be avoided, a slope change between two consecutive slopes **should not** exceed:

- a. 1.5% where the code number is 3 or greater; and
- b. 2% where the code number is 1 or 2.

26. The transition from one slope to another **should** be accomplished by a curved surface with a rate of change not exceeding:

- a. 0.1% per 30 m (minimum radius of curvature of 30000 m) where the code number is 4 or greater;
- b. 0.2% per 30 m (minimum radius of curvature of 15000 m) where the code number is 3; and
- c. 0.4% per 30 m (minimum radius of curvature of 7500 m) where the code number is 1 or 2.

27. Where slope changes on runways cannot be avoided, they **should** be such that there **should** be an unobstructed line of sight from:

- a. Any point 3 m above a runway to all other points 3 m above the runway within a distance of at least half the length of the runway where the code letter is C, D, E, or F.
- b. Any point 2 m above a runway to all other points 2 m above the runway within a distance of at least half the length of the runway where the code letter is B.
- c. Any point 1.5 m above a runway to all other points 1.5 m above the runway within a distance of at least half the length of the runway where the code letter is A.

28. The distance between the points of intersection of two successive curves **should** be the greater of either:

- a. The sum of the absolute numerical values of the corresponding slope changes multiplied by the appropriate value as follows:
 - (1) 30000 m where the code number is 4 or greater;
 - (2) 15000 m where the code number is 3; and
 - (3) 5000 m where the code number is 1 or 2; or
 - (4) 45 m.

Transverse Slope.

29. To promote the most rapid drainage of water, the runway surface **should** be cambered, except where a single cross fall from high to low in the direction of the wind most frequently associated with rain would ensure rapid drainage. Except at runway or taxiway intersections where flatter slopes may be necessary, the transverse slope **should** be:

- a. Not less than 1% and not more than 1.5% where the code letter is C, D, E or F.
- b. Not less than 1% and not more than 2% where the code letter is A or B.

30. For a cambered surface, the transverse slope on each side of the centre-line **should** be symmetrical. The transverse slope **should** be substantially the same throughout the length of a runway except at an intersection with another runway or a taxiway where an even transition **should** be provided taking account of the need for adequate drainage.

**Acceptable
Means of
Compliance
3511(4)****Surface.**

31. The surface of a paved runway **should** be constructed to provide good friction characteristics when the runway is wet.
32. The average surface texture depth of a new surface **should** be not less than 1 mm.
33. If the surface is grooved or scored, the grooves or scorings **should** be either perpendicular to the runway centre-line or parallel to non-perpendicular transverse joints where applicable.
34. Except across the crown of a camber or across drainage channels, the finished surface of the wearing course **should** be of such regularity that, when tested with a 3 m straight-edge placed anywhere in any direction on the surface, there **should** be no deviation greater than 3 mm between the bottom of the straight-edge and the surface of the pavement anywhere along the straight-edge.

Runway Strips.

35. Location - a Runway Strip **should** extend before the threshold and beyond the end of the runway or stopway for a distance of at least:
- 60 m where the code number is 2 or greater;
 - 60 m where the code number is 1 and the runway is an instrument one; and
 - 30 m where the code number is 1 and the runway is a non-instrument one.
36. Precision Approach Runway - a strip including a precision approach runway **should** extend on each side of the centre-line of the runway and its extended centre-line throughout the length of the strip laterally to a distance of at least:
- 140 m where the code number is 3 or greater; and
 - 70 m where the code number is 1 or 2.
37. Non-Precision Approach Runway - a strip including a non-precision approach runway **should** extend on each side of the centre-line of the runway and its extended centre-line throughout the length of the strip laterally to a distance of at least:
- 140 m where the code number is 3 or greater; and
 - 70 m where the code number is 1 or 2.
38. A strip including a non-instrument runway **should** extend on each side of the centre-line of the runway and its extended centre-line throughout the length of the strip, to a distance of at least:
- 75 m where the code number is 3 or greater;
 - 40 m where the code number is 2; and
 - 30 m where the code number is 1.
39. A longitudinal slope along a runway strip **should** be less than:
- 1.5% where the code number is 4 or greater;
 - 1.75% where the code number is 3; and
 - 2% where the code number is 1 or 2.
40. Longitudinal slope changes on a strip **should** be as gradual as practicable, and abrupt changes or sudden reversals of slopes **should** be avoided.
41. Transverse slopes on that portion of a strip to be graded **should** be adequate to prevent accumulation of water on the surface. They **should** be less than 2.5% (where the code number is 3 or greater), or 3% (where the code number is 1 or 2), except that to facilitate drainage from the slope for the first 3 m outward from the direction of the runway, shoulder or stopway edge may be as great as -5% as measured in the direction away from the runway.

**Acceptable
Means of
Compliance
3511(4)**

42. The transverse slopes of any portion of a strip beyond that to be graded **should** be less than an upward slope of 5% as measured in the direction away from the runway.
43. The strip **should** be of sufficient strength such that it does not hinder the movement of rescue and fire fighting vehicles.
44. That portion of a strip of a runway within a stated minimum distance from the centre-line and extended centre-line of the runway **should** provide a graded area and be prepared or constructed to minimise hazards arising from differences in load-bearing capacity to Air Systems which the runway is intended to serve in the event of an Air System running off the runway. The minimum distance **should** be:
- 75 m where the code number is 3 or greater.
 - 40 m where the code number is 2.
 - 40 m where the code number is 1 for an instrument runway.
 - 30 m where the code number is 1 for a non-instrument runway.
45. The surface of that portion of a strip that abuts a runway, shoulder, or stopway **should** be flush with the surface of the runway, shoulder, or stopway.
46. That portion of a strip to at least 30 m before a threshold **should** be prepared against blast erosion to protect a landing Air System from the danger of an exposed edge.
47. The graded portion of runway strips **should** be de-lethalized as indicated in Figure 1; the sub-surface ramp **should** be inclined to the horizontal at a maximum slope of 12.5%.

Figure 1. De-lethalization

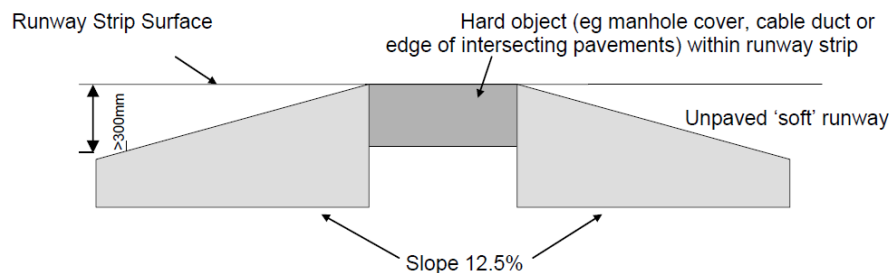

Shoulders.

48. Runway shoulders **should** be provided for a runway where:
- The code letter is D or E, and the runway width is less than 60 m; and
 - The code letter is F.
49. The runway shoulders **should** extend symmetrically on each side of the runway so that the overall width of the runway and its shoulders is not less than:
- 60 m where the code letter is D or E; or
 - 75 m where the code letter is F.
50. The surface of the paved shoulder that abuts the runway **should** be flush with the surface of the runway and its transverse slope **should** be less than 2.5%.
51. A runway shoulder **should** be prepared or constructed to be capable, in the event of an Air System running off the runway, of supporting the Air System without inducing structural damage to the Air System and of supporting ground vehicles which may operate on the shoulder.
52. The surface of a runway shoulder **should** be prepared to resist erosion and prevent the ingestion of the surface material by Air System engines.
53. Longitudinal slopes of shoulders **should** be as for the associated runway.

**Acceptable
Means of
Compliance
3511(4)****Clearways.**

54. A clearway, where provided, **should** be of adequate distance to meet the operational requirements for the Air System which the runway is intended to serve.
55. The origin of a clearway **should** be at the end of the TORA.
56. The length of a clearway **should not** exceed half the length of the TORA.
57. A clearway **should** extend laterally to a distance of at least 75 m on each side of the extended centre-line of the runway.
58. The ground in a clearway **should not** project above a plane having an upward slope of 1.25%, the lower limit of this plane being a horizontal line which:
- Is perpendicular to the vertical plane containing the runway centre-line; and
 - Passes through a point located on the runway centre-line at the end of the TORA.
59. A clearway **should** remain within an aerodrome boundary unless obstacle control can be exercised over the additional land/water outside of the boundary fence.

Stopway.

60. A stopway **should** have a length equal to the ASDA required, less the runway length, and be provided at both ends.
61. A stopway **should** have the same width as the runway with which it is associated including the runway shoulders if present.
62. Slopes and changes in slope on a stopway, and the transition from a runway to a stopway, **should** comply with the specifications of this RA for the runway with which the stopway is associated except that:
- The limitation in this RA of a 0.8% slope for the first and last quarter of the length of a runway need not be applied to the stopway; and
 - At the junction of the stopway and runway and along the stopway the maximum rate of slope change may be 0.3% per 30 m (minimum radius of curvature of 10 000 m) for a runway where the code number is 3 or greater.
63. A stopway **should** be prepared or constructed to be capable, in the event of an abandoned take-off, of supporting the Air System which the stopway is intended to serve without inducing structural damage to the Air System.
64. The surface of a paved stopway **should** be constructed to provide a good coefficient of friction to be compatible with that of the associated runway when the stopway is wet.
65. Concrete blast pads, where provided, **should** be of sufficient size to prevent surface erosion and migration of foreign material onto the runway. The ends **should** comply with the provisions RA 3511(6). Blast pads **should** form part of stopways, in which case they **should** be designed as paved stopways.

Arrestor Net Barrier Overruns.

66. The length of the Arrestor Net Barrier Overrun **should** allow for the full extension of the barrier type used.
67. The pavement construction for Arrestor Net Barrier Overruns **should** be designed as for a stopway, except that a paved surface **should** be provided from the end of the runway up to a point at least 2 m beyond the barrier and, in the case of flexible pavements, a minimum bituminous surfacing thickness of 100 mm **should** be provided. The run-out area beyond this point can either be paved or unpaved designed as for a stopway.

Turn Pads.

68. A runway turn pad **should**:
- Be designed such that when the cockpit of the Air System for which the aerodrome is intended remains over the turn pad marking, the clearance

**Acceptable
Means of
Compliance
3511(4)**

distance between any wheel of the Air System landing gear and the edge of the turn pad is not less than that given by Table 4;

- b. Have an intersection with the runway no greater than 30 degrees; and
- c. Be designed such that the nose wheel steering angle used does not exceed 45 degrees.

69. The longitudinal and transverse slopes on a runway turn pad **should** be the same as those on the adjacent runway pavement surface.

70. The strength of a runway turn pad **should** be compatible with the adjoining runway which it serves.

71. The surface of a runway turn pad **should**:

- a. Be constructed to eliminate surface irregularities that may cause damage to an Air System using the turn pad; and
- b. Be constructed to provide friction characteristics compatible with the runway friction characteristics.

72. The runway turn pad shoulders **should**:

- a. Be of such width as is necessary to prevent surface erosion by the jet blast of the most demanding Air System for which the turn pad is intended and any possible foreign object damage to the Air System engines; and
- b. Have a strength capable of withstanding the occasional passage of the most demanding Air System it is designed to serve without inducing structural damage to the Air System and to the supporting ground vehicles that may operate on the shoulder.

Table 4. Turn Pad Clearance

| <i>Code letter</i> | <i>Clearance</i> |
|--------------------|---|
| A | 1.5 m |
| B | 2.25 m |
| C | 3 m if the turn pad is intended to be used by Air System with a wheel base less than 18 m; 4.5 m if the turn pad is intended to be used by Air System with a wheel base equal to or greater than 18 m. |
| D | 4.5 m |
| E | 4.5 m |
| F | 4.5 m |

Note. – Wheel base means the distance from the nose gear to the geometric centre of the main gear.

Parallel Runway Operations.

73. Where parallel non-instrument runways are intended for simultaneous use, the minimum distance between their centre-lines **should** be:

- a. 210 m where the aerodrome code number is 3 or greater.
- b. 150 m where the aerodrome code number is 2.
- c. 120 m where the aerodrome code number is 1.

74. Where parallel instrument runways are intended for simultaneous use, the minimum distance between their centre-lines **should** be:

- a. 1035 m for independent parallel approaches; and

**Acceptable
Means of
Compliance
3511(4)**

- b. 915 m for dependent parallel approaches; and
 - c. 760 m for independent parallel departures; and
 - d. 760 m for segregated parallel operations.
75. For segregated parallel operations, the specified minimum distance **should** be:
- a. Decreased by 30 m for each 150 m that the arrival runway is staggered toward the arriving Air System, to a minimum of 300 m; and
 - b. Increased by 30 m for each 150 m that the arrival runway is staggered away from the arriving Air System.

Short Take Off and Landing (STOL)/Vertical and/or STOL (VSTOL) Operations.

76. Runway dimensions (length and width) for STOL/VSTOL operations are laid down in respective Air System manuals and will vary from Air System to Air System. The requirements will be dependent on payload and crosswind components and the manuals for the aerodrome/runway design Air System **should** be consulted before any design or construction work is undertaken. In all other respects the runway **should** be treated as a standard runway with the criteria being dictated by the Aerodrome Code Number and Letter.

**Guidance
Material
3511(4)**

Runway - Characteristics

77. The slopes on a runway are intended to prevent the accumulation of water (or possible fluid contaminant) on the surface and to facilitate rapid drainage of surface water (or possible fluid contaminant). The water (or possible fluid contaminant) evacuation is facilitated by an adequate combination between longitudinal and transverse slopes and may also be assisted by grooving the runway surface. Slopes may be so designed as to minimise impact on Air Systems and so not to hamper their operations.
78. Slope changes are designed to reduce dynamic loads on the undercarriage system of the Air System. Minimising slope changes is especially important on runways where Air Systems move at high speeds.
79. For precision approach runways, slopes in a specified area from the runway end, including the touchdown area, may be designed so that they will correspond to the characteristics needed for such type of approach.
80. Caution may be needed when inserting runway lights or drainage grilles in runway surfaces to ensure that adequate smoothness of the surface is maintained.
81. Runway shoulders need to be capable of supporting the Air System using the runway without causing structural damage to those Air Systems. They also need to be capable of supporting vehicles such as firefighting appliances. In some cases, whilst the bearing strength of the natural ground may be sufficient, special preparation may be necessary to avoid erosion and the possible ingestion of debris by engines.
82. Runway shoulders are required because strong crosswinds may result in significant deviation from the runway centre-line. Thus, with some large Air Systems the wing-mounted engines may overhang the runway edge and there is then a risk of jet blast eroding the surface adjacent to the runway. This can cause dust and the possible ingestion of debris by the engines.
83. Paved shoulders may be authorized in special cases (eg for Air Systems with outrigger wheels on the wing-tips or where jet blast from large Air Systems with wing-mounted engines overhanging the pavement edge causing possible Foreign Object Debris (FOD) problems or where the topsoil/climate will not support grassed shoulders).
84. For runways where the code letter is D, there may be circumstances where the shoulder need not be paved. Where the runway is not used by 4-engined Air Systems, it may be possible to contain the risk from erosion or the ingestion of debris in the absence of paved shoulders. In such cases:

**Guidance
Material
3511(4)**

- a. The ground could be prepared so that there is full grass coverage with no loose gravel or other material. This may include additional materials if the bearing strength and surface of the ground are not sufficient.
- b. A programme of inspections of the shoulders and runway may be implemented to confirm its continuing serviceability and ensure that there is no deterioration that could create a risk of FOD, or otherwise hazard Air System operations.
- c. A programme of sweeping may be required before and after movements, if debris is drawn onto the runway surface.

85. If movements of 4-engined Air Systems with a code letter D or larger take place, the need for full paved width shoulders could be assessed by local hazard analysis.

86. Because of transverse or longitudinal slopes on a runway, shoulder, or strip, in certain cases, the lower limit of the clearway plane specified above may be below the corresponding elevation of the runway, shoulder, or strip. It is not intended that these surfaces be graded to conform with the lower limit of the clearway plane

87. Abrupt upward changes in slope need to be avoided when the slope on the ground in a clearway is relatively small or when the mean slope is upward. In such situations, in that portion of the clearway within a distance of 22.5 m or half the runway width whichever is greater, on each side of the extended centre-line, the slopes, slope changes, and the transition from runway to clearway need to generally conform with those of the runway with which the clearway is associated.

88. A stopway needs to be designed to withstand at least a certain number of loadings of the Air System which the stopway is intended to serve without inducing structural damage to the Air System. Notwithstanding that a stopway may have a paved surface, it is not intended that PCN figures need to be developed for a stopway.

89. When an Arrestor Net Barrier is provided, the length of the overrun beyond the barrier need not normally be included in ASDA as not all Air Systems can trample a lowered Barrier.

90. Except that for independent parallel approaches, combinations of minimum distances and associated conditions other than those specified in the ICAO Document 4444² may be applied when it is determined that such combinations would not adversely affect the safety of Air System operations.

91. Procedures and facilities requirements for simultaneous operations on parallel or near-parallel instrument runways are contained in the Doc 4444, Chapter 6 and the ICAO Document 8168³, Volume I, Part III, Section 2, and Volume II, Part I, Section 3; Part II, Section 1; and Part III, Section 3, and relevant guidance is contained in ICAO Document 9643⁴.

92. Guidance on operating surface and strength characteristics may be obtained from global best practice where required, provided the MAA is kept informed of all design decisions and rationale.

Civil Equivalence.

93. This regulation is in line with ICAO Annex 14 Vol I para 3.1.13 – 3.1.23 and para 3.4.

**Regulation
3511(5)**

Runway – Runway-End Safety Areas

3511(5) HoEs and ADH-Facing Organizations **shall** ensure that Runway-End Safety Areas (RESA) are provided for all runways to reduce the risk of damage to an Air System undershooting or over running the runway and to facilitate the movement of rescue and fire fighting vehicles.

² ICAO Document 4444 – Procedures for Air Navigation Services – Air traffic Management (PANS-ATM).

³ ICAO Document 8168 – Procedures for Air Navigation Services – Aircraft Operations (PANS-OPS).

⁴ ICAO Document 9643 – Manual on Simultaneous Operations on Parallel or Near-Parallel Instrument Runways (SOIR).

**Acceptable
Means of
Compliance
3511(5)**

Runway – Runway-End Safety Areas

94. A RESA **should** extend from the end of a runway strip to a distance of at least 90 m and, as far as practicable, extend to a recommended distance of:
- a. 240 m where the code number is 3 or greater;
 - b. 120 m where the code number is 1 or 2 and the runway is an instrument one.
95. Where the code number is 1 or 2 and the runway is a non-instrument one the RESA **should** be at least 30 m.
96. A Safety Audit which takes account of adverse operational factors **should** be provided where the recommended distances are not practicable, notwithstanding compliance with the minimum requirement.
97. The width of a RESA **should** be at least twice that of the associated runway and, wherever practicable, equal to that of the graded portion of the associated runway strip.
98. The longitudinal slopes of a RESA **should** be such that:
- a. No part of the RESA penetrates the approach or take-off climb surface; and
 - b. They do not exceed a downward slope of 5%; and
 - c. Slope changes are as gradual as practicable. Abrupt changes or sudden reversals of slopes are to be avoided.
99. The transverse slopes of a RESA **should** be such that:
- a. They do not exceed an upward or downward slope of 5%; and
 - b. Transitions between differing slopes are as gradual as practicable.
100. Engineered Materials Arrestor System (EMAS) or other arresting system designs **should** be supported by a validated design method that can predict the performance of the system. The design method **should** be derived from field or laboratory tests. Testing may be based either on the passage of an actual Air System or an equivalent single wheel load through a test bed. The design **should** consider multiple Air System parameters, including but not limited to allowable Air System gear loads, gear configuration, tyre contact pressure, Air System centre of gravity and Air System speed. The model **should** calculate imposed Air System gear loads, g-forces on Air System occupants, deceleration rates and stopping distances within the arresting system. Any rebound of the crushed material that may lessen its effectiveness, **should** also be considered.

**Guidance
Material
3511(5)**

Runway – Runway-End Safety Areas

101. It is recognized that achieving the recommended distance could present challenges. Therefore, the aim of this guidance is to identify the types of aerodrome activities that can be undertaken to reduce the likelihood and consequences of an overrun occurring, and to decide on appropriate actions and it is suggested that aerodrome operators assess their RESA provisions.
102. Notwithstanding the provisions in this RA, the length of the RESA may be reduced where an arresting system is installed, based on the design specifications of the system:
- a. Demonstrated performance of an arresting system can be achieved by a validated design method which can predict the performance of the system. The design and performance needs to be based on the type of Air System anticipated to use the associated runway that imposes the greatest demand upon the arresting system. The system design needs to be based on a critical (or design) Air System which is defined as the Air System using the associated runway that imposes the greatest demand upon the arresting system. This is usually but not always, the heaviest/largest Air System that regularly uses the runway. Arresting system performance is dependent not only on Air System weight but landing gear configuration and tyre pressure. All configurations need

**Guidance
Material
3511(5)**

to be considered in optimizing the arresting system design. The aerodrome operator and arresting system manufacturer need to consult regarding the selection of the design Air System that will optimise the arresting system for a particular aerodrome.

103. A RESA could provide an area long and wide enough, and suitable to contain overruns and undershoots resulting from adverse operational factors. On a precision approach runway, the Instrument Landing System (ILS) localiser is normally the first upstanding obstacle, and the RESA could extend up to this facility. In other circumstances and on a non-precision approach runway, the first upstanding obstacle may be a road, a railroad, or other constructed or natural feature. In such circumstances, the RESA could extend as far as the obstacle.

104. Whatever length of RESA is provided, it is important to ensure that likelihood of, and potential impacts arising from, an overrun are minimised as far as reasonably practicable.

105. The overrun is a complex risk to assess because there are several variables, such as prevailing weather, type of Air System, the landing aids available, runway characteristics and available distances, the surrounding environment, and human factors. Each of these can have a significant contribution to the overall hazard; furthermore, the nature of the hazard and level of risk needs to be different for each aerodrome and even for each runway direction at any one aerodrome. The aerodrome may address some, and these are included below. Additionally, Air System operating procedures may impact but the aerodrome may have little ability to influence these. This need not prevent aerodromes from working with Air System operators so that the operations are conducted to minimise the likelihood of an overrun occurring.

106. Aerodromes need to try to maximise the length of RESA available on all applicable runways. When considering the RESA distance required for individual circumstances, aerodrome operators need to consider factors, such as:

- a. The runway length and slope, in particular, the general operating lengths required for take-off and landing versus the runway distances available, including the excess of available length over that required;
- b. Current RESA provision (length and width – how much the RESA complies with the recommended distance) and options to increase or improve this;
- c. The nature and location of any hazard beyond the runway end, including the topography and obstruction environment in and beyond the RESA and outside the runway strip;
- d. The type of Air System and level of traffic at the aerodrome, and actual or proposed changes to either;
- e. Air System performance limitations arising from runway and RESA length – high performance Air Systems, operating at high loads and speeds have greater length requirements than smaller, low-performance Air Systems, the relationship between required balanced field length and available distances;
- f. Navigation aids available (Performance Based Navigation (PBN)), instrument or visual - if an ILS is only available on one runway direction, a downwind approach and landing may be necessary in poor weather, and the availability of vertical guidance;
- g. Friction and drainage characteristics of the runway, which impact on runway susceptibility to surface contamination and Air System braking action;
- h. Traffic density, which may lead to increased pressure to vacate so increased speed;
- i. Aerodrome weather patterns, including wind shear;
- j. Aerodrome overrun history; and
- k. Overrun/undershoot causal factors.

**Guidance
Material
3511(5)**

107. Measures may be considered that would reduce the severity of the consequences if an event occurs. Wherever practicable, aerodrome operators need to seek to optimize the RESA. This may be achieved through a combination of:

- a. Relocation, shifting or realignment of the runway — it may be possible to construct additional pavement at the start of take-off end to make more pavement available to retain the declared distances. The start and end of declared distances can be moved towards the downwind (start of take-off) end, thereby retaining the declared distance and creating space for a longer RESA.
- b. In the case where undershoot RESA is limited and the runway has a displaced landing threshold, examine whether the threshold can be moved (downwind) to increase the RESA and/or runway length;
- c. Reducing runway declared distances to provide the necessary RESA may be a viable option where the existing runway length exceeds that required for the existing or projected design Air System. If the take-off distance required for the critical Air System operating at the aerodrome is less than the take-off distance available, there may be an opportunity to reduce the relevant runway declared distances;
- d. Increasing the length of a RESA, and/or minimising the obstruction environment in the area beyond the RESA. Means to increase the RESA provision include land acquisition, improvements to the grading, realigning fences or roads to provide additional area;
- e. Installing suitably positioned and designed arresting systems, to supplement, or as an alternative to, a RESA where an equivalent level of safety is demonstrated;
- f. Improving the slopes in the RESA to minimise or remove downward slopes; and
- g. Providing paved RESA with known friction characteristics.

Civil Equivalence.

108. This regulation is in line with ICAO Annex 14 Vol I para 3.5.

**Regulation
3511(6)**

Taxiway - Characteristics

3511(6) HoEs and ADH-Facing Organizations **shall** ensure that the Taxiway physical characteristics are designed to enable the stabilised and safe use of the taxiway by the Air System for which the aerodrome is intended.

**Acceptable
Means of
Compliance
3511(6)**

Taxiway - Characteristics

Width.

109. The minimum clearance from the taxiway edge to the outer main wheel, with the Air System cockpit remaining on the taxiway centre-line **should** be:

- a. Aerodrome Code A - 1.5 m;
- b. Aerodrome Code B - 2.25 m;
- c. Aerodrome Code C – 3 m (wheel base less than 18 m);
- d. Aerodrome Code C - 4.5 m (wheel base greater than 18 m); and
- e. Aerodrome Code D or greater - 4.5 m.

110. Fillets **should** be provided at junctions and intersections of taxiways with runways, aprons, and other taxiways to ensure that the minimum wheel clearances are maintained.

111. Straight portions of taxiway **should** have a width not less than:

- a. Aerodrome Code A - 7.5 m;

**Acceptable
Means of
Compliance
3511(6)**

- b. Aerodrome Code B - 10.5 m;
- c. Aerodrome Code C – 15 m (wheel base less than 18 m);
- d. Aerodrome Code C – 18 m (wheel base greater than 18 m);
- e. Aerodrome Code D – 18 m (wheel base less than 18 m);
- f. Aerodrome Code D – 23 m (wheel base greater than 18 m);
- g. Aerodrome Code E – 23 m; and
- h. Aerodrome Code F – 25 m.

112. Changes in direction of taxiways **should** be as few and small as possible.

113. The radii of the curves **should** be compatible with the manoeuvring capability and normal taxiing speeds of the Air System for which the taxiway is intended and not less than 60 m.

Strength.

114. The strength of taxiways **should** be at least equal to that of the runways that they serve.

Surface.

115. The surface of a taxiway **should not** have irregularities that cause damage to Air System structures.

Longitudinal Slope.

116. The longitudinal slope of a taxiway **should not** exceed:

- a. 1.5% where the aerodrome code letter is C, D, E, or F.
- b. 3% where the aerodrome code letter is A or B.

117. Where slope changes on a taxiway cannot be avoided, the transition from one slope to another slope **should** be accomplished by a curved surface with a rate of change not exceeding:

- a. 1% per 30 m (minimum radius of curvature of 3000 m) where the aerodrome code letter is C, D, E, or F.
- b. 1% per 25 m (minimum radius of curvature of 2500 m) where the aerodrome code letter is A or B.

118. Where a change in slope on a taxiway cannot be avoided, the change **should** be such that, from any point:

- a. 3 m above the taxiway, it **should** be possible to see the whole surface of the taxiway for a distance of at least 300 m from that point where the aerodrome code letter is C, D, E, or F.
- b. 2 m above the taxiway, it **should** be possible to see the whole surface of the taxiway for a distance of at least 200 m from that point where the aerodrome code letter is B.
- c. 1.5 m above the taxiway, it **should** be possible to see the whole surface of the taxiway for a distance of at least 150 m from that point where the aerodrome code letter is A.

119. The distance between the tangent points of gradient changes **should** be no less than 150 m.

Transverse Slope.

120. The transverse slopes of a taxiway **should** be sufficient to prevent the accumulation of water on the surface of the taxiway but **should** be no greater than:

- a. 1.5% where the aerodrome code letter is C, D, E, or F.
- b. 2% where the aerodrome code letter is A or B.

Acceptable Means of Compliance 3511(6)

Strips.

121. A taxiway strip **should** extend symmetrically on each side of the centre-line of the taxiway throughout the length of the taxiway to at least the distance from the centre-line given in Table 5.

Table 5. Taxiway minimum separation distances

| Code letter | Distance between taxiway centre-line and runway centre-line (metres) | | | | | | | | Taxiway centre-line to taxiway centre-line (metres) | Taxiway, other than Air System stand taxilane, centre-line to object (metres) | Air System stand taxilane centre line to aircraft stand taxilane centre line (metres) | Air System stand taxilane centre-line to object (metres) |
|-------------|--|------|-----|-------|------------------------------------|------|-----|-------|---|---|---|--|
| | Instrument runways Code number | | | | Non-instrument runways Code number | | | | | | | |
| | 1 | 2 | 3 | 4 | 1 | 2 | 3 | 4 | | | | |
| (1) | (2) | (3) | (4) | (5) | (6) | (7) | (8) | (9) | (10) | (11) | (12) | (13) |
| A | 82.5 | 82.5 | - | - | 37.5 | 47.5 | - | - | 23 | 15.5 | 19.5 | 12 |
| B | 87 | 87 | - | - | 42 | 52 | - | - | 32 | 20 | 28.5 | 16.5 |
| C | - | - | 168 | - | - | - | 93 | - | 44 | 26 | 40.5 | 22.5 |
| D | - | - | 176 | 176 | - | - | 101 | 101 | 63 | 37 | 59.5 | 33.5 |
| E | - | - | - | 182.5 | - | - | - | 107.5 | 76 | 43.5 | 72.5 | 40 |
| F | - | - | - | 190 | - | - | - | 115 | 91 | 51 | 87.5 | 47.5 |

Note 1 ►◄

Note 2 – The separation distances shown in columns (2) to (9) represent ordinary combinations of runways and taxiways. The basis for development of these distances is given in the Aerodrome Design Manual (ICAO Doc 9157), Part 2.

Note 3 – The distances in columns (2) to (9) do not guarantee sufficient clearance behind a holding aircraft to permit the passing of another aircraft on a parallel taxiway. See the Aerodrome Design Manual (ICAO Doc 9157), Part 2.

122. The centre portion of a taxiway strip **should** provide a graded area to a distance from the centre-line of the taxiway of at least:

- a. 11 m where the aerodrome code letter is A;
- b. 12.5 m where the aerodrome code letter is B or C;
- c. 19 m where the aerodrome code letter is D;
- d. 22 m where the aerodrome code letter is E; and
- e. 30 m where the aerodrome code letter is F.

123. The surface of the taxiway strip **should** be flush at the edge of the taxiway or shoulder if provided.

124. The graded portion of a taxiway strip **should** have an upward transverse slope no greater than:

- a. 2.5% for strips where the aerodrome code letter is C, D, E, or F; and
- b. 3% for strips of taxiways where the aerodrome code letter is A or B.

125. The upward slope **should** be measured with reference to the transverse slope of the adjacent taxiway surface and not the horizontal.

126. The graded portion of a taxiway strip **should** have a downward transverse slope no greater than 5% measured with reference to the horizontal slope.

127. The transverse slopes on any portion of a taxiway strip beyond that to be graded **should** have an upward or downward slope no greater than 5% as measured in the direction away from the runway.

**Acceptable
Means of
Compliance
3511(6)**

Shoulders.

128. Straight portions of a taxiway **should** be provided with shoulders which extend symmetrically on each side of the taxiway so that the overall width of the taxiway and its shoulders is not less than:

- a. 44 m where the aerodrome code letter is F.
- b. 38 m where the aerodrome code letter is E.
- c. 34 m where the aerodrome code letter is D.
- d. 25 m where the aerodrome code letter is C.

129. On taxiway curves and on junctions or intersections where increased pavement is provided, the shoulder width **should not** be less than that on the adjacent straight portions of the taxiway.

130. When a taxiway is intended to be used by turbine-engine Air Systems, the surface of the taxiway shoulder **should** be prepared to resist erosion and the ingestion of the surface material by Air System engines.

131. Taxiway shoulder transverse slopes **should** be between -1.5 and +3%.

132. Longitudinal slopes of shoulders **should** be as for the associated taxiway iaw RA 3511(4).

Parallel Taxiways.

133. A Risk Assessment **should** be completed to support operations from a parallel taxiway.

134. If provided, an aerodrome **should** have only one parallel taxiway assigned for the purpose of allowing take-offs and landings.

135. The design of a parallel taxiway that can be used for take-off and landing, **should** conform to the specifications as detailed in Table 6.

136. The surface of a paved parallel taxiway that can be used for take-off and landing **should** be constructed to provide good friction characteristics when the runway is wet.

137. The taxiway **should** be of sufficient strength to support normal operations of the Air System intended for use at the aerodrome without risk of damage either to the Air System or the taxiway.

Table 6. Parallel Taxiways

| Facility | Length | Width | Slopes | |
|---|---|--|---|------------|
| | | | Longitudinal | Transverse |
| Parallel Taxiway | As for main runway | ≥23 m | As for main runway | |
| Shoulders | Full length | ≥30 m from taxiway edge | | |
| Clearway ^{ab} | ≤150 m | 52.5 m | Not to project above plane through end of taxiway with slope = 2% | ≤3% |
| Stopway | Not Required | | | |
| Strip | 60 m beyond parallel taxiway ends | 100 m to each side of parallel taxiway centre-line | As for main runway | |
| Separation Distances | a. To runway centre-line – 150 m b. To ►Aprons◄ – 100 m c. To nearest building, facility etc. – 100 m d. To the centre-line of nearest taxiway – 100 m | | | |
| ^a At both ends of the taxiway | | | | |
| ^b Not to extend beyond runway clearway | | | | |

**Acceptable
Means of
Compliance
3511(6)**

Separation Distances.

138. The separation distance between the centre-line of a taxiway and the centre-line of a runway, the centre-line of a parallel taxiway, the centre-line of an Air System stand, or an object **should** be no less than the appropriate dimension specified in Table 5.

Holding Positions.

139. Holding bays or other bypasses of sufficient size and adequate construction **should** be provided where necessary, to allow for sequencing departing Air Systems.

140. A runway-holding position or positions **should** be established:

- a. On the taxiway, if the location or alignment of the taxiway is such that a taxiing Air System or vehicle can infringe an obstacle limitation surface or interfere with the operation of radio navigation aids; and
- b. On the taxiway, at the intersection of a taxiway and a runway; and
- c. At an intersection of a runway with another runway when the former runway is part of a standard taxi-route.

141. An intermediate holding position **should** be established on a taxiway at any point other than a runway-holding position where it is desirable to define a specific holding limit.

142. An emergency access road **should** be equipped with road-holding positions at all intersections with runways and taxiways.

143. A road-holding position **should** be established at each intersection of a road with a runway.

144. The distance between a holding bay, runway-holding position established at a taxiway/runway intersection or road-holding position and the centre-line of a runway **should** be as Table 7 and such that a holding Air System or vehicle **should not** infringe obstacle free zones, approach surfaces, or the take-off climb surface, nor interfere with the operation of radio navigation aids.

145. At elevations greater than 700 m, the distance of 90 m specified in Table 7 for a precision approach runway code number 4 **should** be increased as follows:

- a. Up to an elevation of 2000 m; 1 m for every 100 m in excess of 700 m; and
- b. Elevation in excess of 2000 m and up to 4000 m; 13 m plus 1.5 m for every 100 m in excess of 2000 m; and
- c. Elevation in excess of 4000 m and up to 5000 m; 43 m plus 2 m for every 100 m in excess of 4000 m.

Table 7. Minimum distance from the runway centre-line to a holding bay, runway-holding position or road-holding position

| Type of runway | Code number | | | |
|--|-------------------|-------------------|----------------------|-------------------------|
| | 1 | 2 | 3 | 4 |
| Non-instrument | 30 m | 40 m | 75 m | 75 m |
| Non-precision approach | 40 m | 40 m | 75 m | 75 m |
| Precision approach category I | 60 m ^b | 60 m ^b | 90 m ^{a, b} | 90 m ^{a, b, c} |
| Precision approach categories II and III | - | - | 90 m ^{a, b} | 90 m ^{a, b, c} |
| Take-off runway | 30 m | 40 m | 75 m | 75 m |

Acceptable Means of Compliance 3511(6)

- a. If a holding bay, runway-holding position or road-holding position is at a lower elevation compared to the threshold, the distance may be decreased 5 m, for every metre the bay or holding position is lower than the threshold, contingent upon not infringing the inner transitional surface.
- b. This distance may need to be increased to avoid interference with radio navigation aids, particularly the glide path and localizer facilities.

Note 1 – The distance of 90 m for code number 3 or 4 is based on an Air System with a tail height of 20 m, a distance from the nose to the highest part of the tail of 52.7 m and a nose height of 10 m holding at an angle of 45° or more with respect to the runway centre-line, being clear of the obstacle free zone.

Note 2 – The distance of 60 m for code number 2 is based on an Air System with a tail height of 8 m, a distance from the nose to the highest part of the tail of 24.6 m and a nose height of 5.2 m holding at an angle of 45° or more with respect to the runway centre-line, being clear of the obstacle free zone.

- c. Where the code letter is F, this distance **should** be 107.5 m.

Note 3 – The distance of 107.5 m for code number 4 where the code letter is F is based on an Air System with a tail height of 24 m, a distance from the nose to the highest part of the tail of 62.2 m, and a nose height of 10 m holding at an angle of 45° or more with respect to the runway centre-line, being clear of the obstacle free zone.

Guidance Material 3511(6)

Taxiway - Characteristics

146. Due consideration needs to be given to the fact that a taxiway may be subjected to a greater density of traffic and as a result of slow moving and stationary Air Systems, leading to higher stresses than the runway it serves.

147. Where slope changes specified above are not achieved and slopes on a taxiway cannot be avoided, the transition from one slope to another slope needs to be accomplished by a curved surface which needs to allow the safe operation of all Air Systems in all weather conditions.

148. Paved shoulders may be authorized in special cases (eg for Air Systems with outrigger wheels on the wing-tips or where jet blast from large Air Systems with wing-mounted engines overhanging the pavement edge causing possible FOD problems or where the topsoil/climate will not support grassed shoulders).

Civil Equivalence.

149. This regulation is in line with ICAO Annex 14 Vol I paras 3.9 – 3.12.

Regulation 3511(7)

Aprons

3511(7) HoEs and ADH-Facing Organizations **shall** ensure that Aprons are adequate to permit safe and expeditious handling of aerodrome traffic at its maximum anticipated density.

Acceptable Means of Compliance 3511(7)

Aprons Size.

150. For Dispersed Stands and Hangar/Hardened Aircraft Shelter (HAS) Aprons, the size of the apron **should** be no less than the turning radius of the Air System's outer wheels plus 3 m.

Clearance.

151. An Air System stand **should** provide the following minimum clearances between an Air System using the stand and any adjacent objects as follows:

- a. Aerodrome code letter A and B: 3 m.
- b. Aerodrome code letter C: 4.5 m.

**Acceptable
Means of
Compliance
3511(7)**

- c. Aerodrome code letter D or greater: 7.5 m.

Strength.

152. The strength of aprons **should** be at least equal to that of the runways that they serve.

Surface.

153. The surface of an apron **should** be constructed or resurfaced to provide suitable surface friction characteristics iaw ICAO Annex 14 Vol I Attachment A, section 7.

Slope.

154. The design of slopes **should** direct spilled fuel away from buildings and apron service areas. Where such slopes are unavoidable, special measures **should** be taken to reduce the fire hazard resulting from fuel spillage.

155. On an Air System stand the maximum slope **should** be no greater than 1% in any direction.

156. Where the slope limitation of 1% on the stands cannot be achieved, the slope **should** be kept as shallow as possible and **should** be such that the operation of the Air Systems and vehicles is not compromised.

Strip.

157. For aprons and dispersed stands, the apron strip **should** extend no less than 15 m from edge of paved surface.

158. For Hangar/HAS aprons, the apron strip **should** extend no less than the greater of:

- a. 5m from the edge of the paved surface; or
- b. Half the wingspan of the Air System the Apron is intended to serve from the edge of the paved surface.

Shoulder.

159. Apron shoulders **should** extend no less than 3 m from the edge of the paved surface.

**Guidance
Material
3511(7)**

Aprons

160. The amount of area required for an apron layout will depend upon the following factors:

- a. The size and manoeuvrability characteristics of the Air System using the apron.
- b. The volume of traffic using the apron.
- c. Clearance requirements.
- d. Type of ingress and egress to the Air System stand.
- e. Aerodrome layout or other aerodrome use.
- f. Air System ground activity requirements.
- g. Taxiways and service roads.

161. Due consideration needs to be given to the fact that an apron may be subjected to a greater density of traffic and as a result of slow moving and stationary Air Systems, to higher stresses than the runway it serves.

162. Slopes on aprons have the same purpose as other pavement slopes, to prevent the accumulation of water (or possible fluid contaminant) on the surface and to facilitate rapid drainage of surface water (or possible fluid contaminant). Nevertheless, the design of the apron, especially for the parts containing Air System stands, must specifically consider the impact of the slopes on the Air System during its braking at the stand and during its start for departure (with push-back or with its own engines). The aim is to avoid an Air System passing its stop point and going on the service road

**Guidance
Material
3511(7)**

or to the closest building and to save fuel and optimize the manoeuvrability of the Air System or of the push-back device.

Civil Equivalence.

163. This regulation is in line with ICAO Annex 14 Vol I 3.13.

RA 3512 - Permanent Fixed Wing Aerodrome - Obstacle Environment

Rationale

The presence of obstacles such as trees, buildings or cranes, in and around an Aerodrome could affect the safe operation of ► *Aircraft*. ◀ The purpose of the Obstacle Limitation Surfaces (OLS) is to define the airspace around Aerodromes that is to be maintained free from obstacles to permit the intended ► *Aircraft* ◀ operations at the Aerodromes to be conducted safely.

Contents

3512(1): Obstacle Limitation Surfaces

3512(2): Obstacle Free Zones

3512(3): Obstacle Limitation Surfaces Requirements - Non-Instrument Runways

3512(4): Obstacle Limitation Surfaces Requirements - Non-Precision Approach Runways

3512(5): Obstacle Limitation Surfaces Requirements - Precision Approach (Cat I) Runways

3512(6): Obstacle Limitation Surfaces Requirements - Precision Approach (Cat II / III) Runways

3512(7): Obstacle Limitation Surfaces Requirements - Runways Meant For Take-Off

3512(8): Objects Outside the Obstacle Limitation Surfaces

Regulation

3512(1)

Obstacle Limitation Surfaces

3512(1) Heads of Establishments (HoEs) and Aviation Duty Holder-Facing Organizations (ADH-Facing Organizations) **shall** ensure that OLS are established to limit the extent to which objects may project into the airspace around the Aerodrome(s) for which they are responsible.

Acceptable Means of Compliance

3512(1)

Obstacle Limitation Surfaces

Outer Horizontal.

1. ► The outer horizontal surface is of particular importance for safe operations in areas of high ground or where there are concentrations of obstacles. It represents the level above which consideration **should** be given to the control of new obstacles in order to facilitate practicable and efficient instrument approach procedures, and together with the conical and inner horizontal surfaces to ensure safe visual manoeuvring in the vicinity of an Aerodrome. ◀ The outer horizontal surface **should**:
 - a. ► Be established for every Aerodrome where the main Runway is 1100 m or more in length; and
 - b. Be a horizontal plane extending from the periphery of the conical surface (Figure 1) to a minimum radius of 15000 m from the Aerodrome reference point when the main Runway is 1860 m or more in length, and to a minimum radius of 10000 m where the main Runway is 1100 m or more but less than 1860 m in length; ◀ and
 - c. Have an upper edge equal to the total height of the inner horizontal and conical surfaces.

Conical Surface.

2. The conical surface **should**:

**Acceptable
Means of
Compliance
3512(1)**

- a. Be a surface sloping upwards and outwards from the periphery of the inner horizontal surface (Figure 1);
- b. Have a lower edge coincident with the periphery of the inner horizontal surface;
- c. Have an upper edge located at a specified height above the inner horizontal surface; and
- d. Have a slope measured in a vertical plane perpendicular to the periphery of the inner horizontal surface.
- e. Use the same reference point as for the inner horizontal surface.

Inner Horizontal.

3. The inner horizontal surface **should**:
 - a. Protect airspace for visual circling prior to landing;
 - b. Be a horizontal plane above an Aerodrome and its environs (Figure 1);
 - c. Have outer limits defined by circular arcs centred on
 - (1) For Aerodrome Codes 1 - 3, the midpoint between the Runway ends, excluding clearways and stopways;
 - (2) For Aerodrome Codes 4 - 6, the Runway ends, excluding clearways and stopways.
 - d. Have a height measured above an established elevation datum. The elevation datum used for the height of the inner horizontal surface **should** be:
 - (1) The elevation of the highest point of the lowest threshold of the related Runway; or
 - (2) The elevation of the highest point of the highest threshold of the related Runway; or
 - (3) The elevation of the highest point of the Runway; or
 - (4) The Aerodrome elevation.

Approach surface.

4. The approach surface **should**:
 - a. Be an inclined plane or combination of planes preceding the threshold (Figure 1);
 - b. Have limits comprising:
 - (1) An inner edge of specified length, horizontal and perpendicular to the extended centre-line of the Runway, and located at a specified distance before the threshold;
 - (2) Two sides originating at the ends of the inner edge and diverging uniformly at a specified rate from the extended centre-line of the Runway; and
 - (3) An outer edge parallel to the inner edge.
 - c. Have an elevation equal to the elevation of the mid-point of the threshold;
 - d. Have a slope measured in the vertical plane containing the centre-line of the Runway and **should** continue containing the centre-line of any lateral offset or curved ground track; and
 - e. Be varied when lateral offset, offset or curved approaches are utilized, specifically, two sides originated at the ends of the inner edge and diverging uniformly at a specified rate from the extended centre-line of the lateral offset, or curved ground track.

Transitional Surface.

5. The transitional surface **should**:

**Acceptable
Means of
Compliance
3512(1)**

- a. Extend from the side of the Runway strip and part of the side of the approach surface and slope upwards and outwards to the inner horizontal surface (Figure 1)¹;
- b. Have limits comprising:
 - (1) A lower edge beginning at the intersection of the side of the approach surface with the inner horizontal surface and extending down the side of the approach surface to the inner edge of the approach surface and from there along the length of the strip parallel to the Runway centre-line; and
 - (2) An upper edge located in the plane of the inner horizontal surface.
- c. Have an elevation of the lower edge that is:
 - (1) Along the side of the approach surface - equal to the elevation of the approach surface at that point; and
 - (2) Along the strip - equal to the elevation of the nearest point on the centre-line of the Runway or its extension.
- d. Have a slope measured in a vertical plane at right angles to the centre-line of the Runway.

Take-off Climb Surface.

6. The take-off Climb Surface **should**:
 - a. Be an inclined plane or other specified Surface beyond the end of the Runway or clearway (Figure 1)²;
 - b. Have limits comprising:
 - (1) An inner edge horizontal and perpendicular to the centre-line of the Runway, and located either at a specified distance beyond the end of the Runway, or at the end of the clearway when such is provided, and its length exceeds the specified distance;
 - (2) Two sides originating at the ends of the inner edge, diverging uniformly at a specified rate from the take-off track to a specified final width and continuing thereafter at that width for the remainder of the length of the take-off Climb Surface; and
 - (3) An outer edge horizontal and perpendicular to the specified take-off track.
 - c. Have an elevation of the inner edge equal to the highest point on the extended Runway centre-line between the end of the Runway and the inner edge, except that when a clearway is provided, the elevation **should** be equal to the highest point on the ground on the centre-line of the clearway; and
 - d. Have a slope that:
 - (1) For a straight take-off flight path, is measured in the vertical plane containing the centre-line of Runway; or
 - (2) For a take-off flight path involving a turn, is a complex surface containing the horizontal normal to its centre-line, and the slope of the centre-line **should** be the same as that for a straight take-off flight path.
7. Objects which do not project through the approach surface, but which would nevertheless adversely affect the optimum siting or performance of visual or non-visual aids **should**, as far as practicable, be removed.

¹ Includes the Runway strip for statutory safeguarding purposes.

² For statutory safeguarding purposes, the take-off climb surfaces will not be varied where the take-off flight path involves a turn. The elevation of the inner edge will be highest point on the extended Runway centreline or clearway supplied on the Measured Height Survey.

Acceptable Means of Compliance 3512(1)

Figure 1. Obstacle Limitation Surfaces

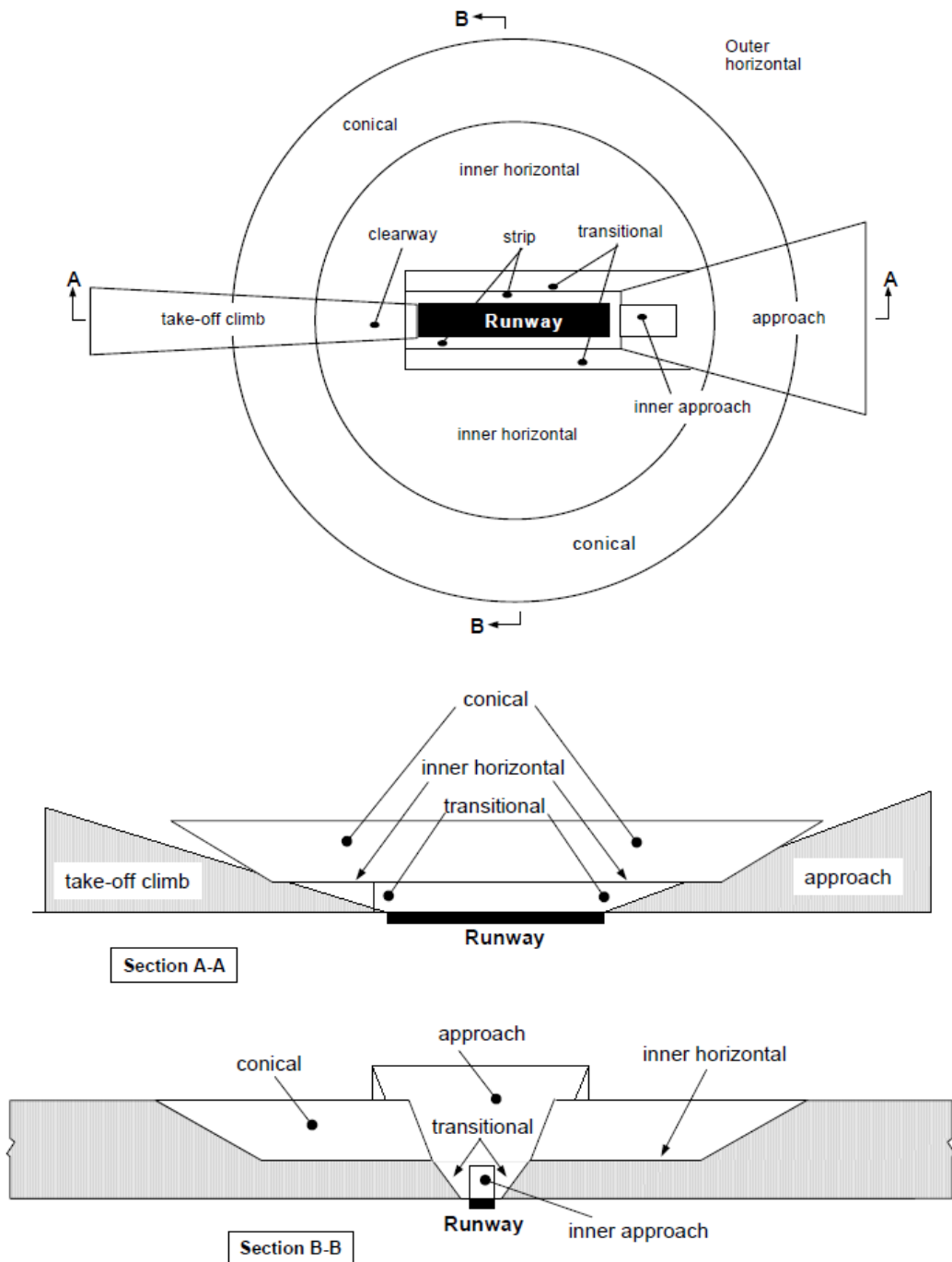

Guidance Material 3512(1)

Obstacle Limitation Surfaces

- 8. The purpose of the transitional surface is to define the limit of the area available for buildings, other structures or natural obstructions, such as trees.
- 9. The purpose of the take-off Climb Surface is to protect an ► Aircraft ◀ on take-off and during climb-out.
- 10. Objects which penetrate the OLS may, in certain circumstances, cause an increase in the Obstacle Clearance Altitude / Height (OCA / H) for an instrument approach procedure or any associated visual circling procedure.

Civil Equivalence.

- 11. This Regulation is in line with International Civil Aviation Organization (ICAO) Annex 14 Vol I para 4.1.

**Regulation
3512(2)**

Obstacle Free Zones

3512(2) HoEs and ADH-Facing Organizations **shall** ensure that the Obstacle Free Zone is established, consisting of the following OLS; inner approach surface, inner transitional surface and balked landing surface.

**Acceptable
Means of
Compliance
3512(2)**

Obstacle Free Zones

Inner Approach surface.

12. The inner approach surface **should**:
- a. Protect final precision approaches.
 - b. Be a rectangular portion of the approach surface immediately preceding the threshold (Figure 2); and
 - c. Have limits comprising:
 - (1) An inner edge coincident with the location of the inner edge of the approach surface but of its own specified length;
 - (2) Two sides originating at the ends of the inner edge and extending parallel to the vertical plane containing the centre-line of the Runway; and
 - (3) An outer edge parallel to the inner edge.

Inner Transitional Surface.

13. The inner transitional surface **should**:
- a. Protect ► **Aircraft** ◀ during precision approaches and balked landing.
 - b. Be a Surface similar to the transitional surface but closer to the Runway (Figure 2);
 - c. Have limits comprising:
 - (1) A lower edge beginning at the end of the inner approach surface and extending down the side of the inner approach surface to the inner edge of that surface, from there along the strip parallel to the Runway centre-line to the inner edge of the balked landing surface, and from there up the side of the balked landing surface to the point where the side intersects the inner horizontal surface; and
 - (2) An upper edge located in the plane of the inner horizontal surface.
 - d. Have an elevation of the lower edge that is:
 - (1) Along the side of the inner approach surface and balked landing surface - equal to the elevation of the particular surface at that point; and
 - (2) Along the strip - equal to the elevation of the nearest point on the centre-line of the Runway or its extension.
 - e. Have a slope that is measured in a vertical plane at right angles to the centre-line of the Runway.

Balked Landing Surface.

14. The balked landing surface **should**:
- a. Protect an ► **Aircraft** ◀ in the event of a balked landing.
 - b. Be an inclined plane located at a specified distance after the threshold, extending between the inner transitional surfaces (Figure 2);
 - c. Have limits comprising:
 - (1) An inner edge horizontal and perpendicular to the centre-line of the Runway and located at a specified distance after the threshold;

Acceptable Means of Compliance 3512(2)

- (2) Two sides originating at the ends of the inner edge and diverging uniformly at a specified rate from the vertical plane containing the centre-line of the Runway; and
 - (3) An outer edge parallel to the inner edge and located in the plane of the inner horizontal surface.
- d. Have an elevation of the inner edge equal to the elevation of the Runway centre-line at the location of the inner edge; and
 - e. Have a slope that is measured in the vertical plane containing the centre-line of the Runway.
15. Only frangible mounted obstacles, such as Aerodrome Ground Lighting (AGL) fittings, which are operationally essential, constructed and sited to reduce the Hazard to a minimum, **should** be used. Other operationally essential items include Runway caravans, arrestor installations and Runway Visual Range (RVR) towers³. Guidance on frangibility is contained in the ICAO Aerodrome Design Manual (Doc 9157), Part 6.

Figure 2. Inner Approach, Inner Transitional and Balked Landing OLS.

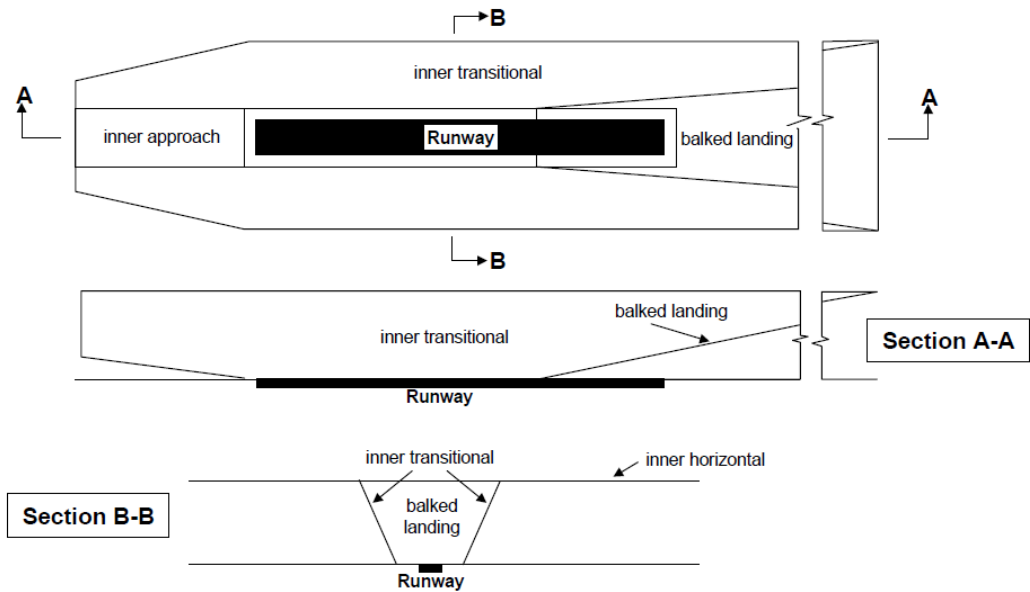

Guidance Material 3512(2)

Obstacle Free Zones

16. The Obstacle Free Zones surfaces are not calculated or mapped for safeguarding purposes.

Civil Equivalence.

17. This Regulation is in line with ICAO Annex 14 Vol I para 4.1.

Regulation 3512(3)

Obstacle Limitation Surfaces Requirements - Non-Instrument Runways

3512(3) HoEs and ADH-Facing Organizations **shall** ensure that the following obstacle limitation surfaces are established for a non-instrument Runway; conical, inner horizontal, outer horizontal, take-off climb, approach and transitional.

³ Refer to RA 3590(12): Safeguarding – Operationally Essential Obstructions.

**Acceptable
Means of
Compliance
3512(3)**

**Obstacle Limitation Surfaces Requirements - Non-Instrument
Runways**

18. The heights and slopes of the OLS **should** be in accordance with (iaw) those specified in Annex A.
19. New objects or extensions of existing objects **should not** be permitted above an approach surface within 3000 m of the inner edge or above a transitional surface except when the new object or extension would be shielded by an existing immovable object.
20. New objects or extensions of existing objects **should not** be permitted above the conical surface, inner horizontal surface ► or outer horizontal surface ◀ except when the object would be shielded by an existing immovable object, or after Safety Assessment, it is determined that the object would not adversely affect the Safety or significantly affect the regularity of operations of ► Aircraft. ◀
21. Existing objects above any of the conical surface, inner horizontal surface, approach surface and transitional surfaces **should** be removed except when the object is shielded by an existing immovable object, or after Safety Assessment it is determined that the object would not adversely affect the Safety or significantly affect the regularity of operations of ► Aircraft. ◀

**Guidance
Material
3512(3)**

**Obstacle Limitation Surfaces Requirements - Non-Instrument
Runways**

22. In considering proposed construction, account may be taken of the possible future development of an instrument Runway and consequent requirement for more stringent OLS.

Civil Equivalence.

23. This Regulation is in line with ICAO Annex 14 Vol I para 4.2.

**Regulation
3512(4)**

**Obstacle Limitation Surfaces Requirements - Non-Precision
Approach Runways**

- 3512(4) HoEs and ADH-Facing Organizations **shall** establish the following OLS for a non-precision approach Runway, conical, inner horizontal, outer horizontal, take-off climb, approach, and transitional.

**Acceptable
Means of
Compliance
3512(4)**

**Obstacle Limitation Surfaces Requirements - Non-Precision
Approach Runways**

24. The heights and slopes of the OLS **should** be iaw those specified in Annex A.
25. The approach surface **should** be horizontal beyond the point at which the 2.5% slope intersects the higher of:
- a. A horizontal plane 150 m above the threshold elevation; or
 - b. The horizontal plane passing through the top of any object that governs the OCA/H.
26. New objects or extensions of existing objects **should not** be permitted:
- a. Above an approach surface within 3000 m of the inner edge or above a transitional Surface, except when the new object or extension would be shielded by an existing immovable object.
 - b. Above the approach surface beyond 3000 m from the inner edge, the conical Surface or inner horizontal surface except when the object would be shielded by an existing immovable object, or after a Safety Assessment, it is determined that the object would not adversely affect the Safety or significantly affect the regularity of operations of ► Aircraft. ◀

**Acceptable
Means of
Compliance
3512(4)**

27. Existing objects above any of the surfaces required by ►this RA◄ **should** be removed except when the object would be shielded by an existing immovable object or, after Safety Assessment, it is determined that the object would not adversely affect the Safety or significantly affect the regularity of operations of ►Aircraft.◄

**Guidance
Material
3512(4)**

Obstacle Limitation Surfaces Requirements - Non-Precision Approach Runways

Civil Equivalence.

28. This Regulation is in line with ICAO Annex 14 Vol I para 4.2.

**Regulation
3512(5)**

Obstacle Limitation Surfaces Requirements - Precision Approach (Cat I) Runways

3512(5) HoEs and ADH-Facing Organizations **shall** establish OLS for the following on a Precision Approach Runway Category I; conical, inner horizontal, outer horizontal, inner approach, take-off climb, approach, and transitional.

**Acceptable
Means of
Compliance
3512(5)**

Obstacle Limitation Surfaces Requirements - Precision Approach (Cat I) Runways

29. The heights and slopes of the surfaces **should not** be greater than, and their other dimensions **should not** be less than, those specified in Annex A, except in the case of the horizontal section of the approach surface (see below).

30. The approach surface **should** be horizontal beyond the point at which the 2.5% slope intersects the higher of:

- a. A horizontal plane 150 m above the threshold elevation; or
- b. The horizontal plane passing through the top of any object that governs the obstacle clearance limit.

31. Fixed objects **should not** be permitted above the inner approach surface, the inner transitional surface or the balked landing surface, except for frangible objects which because of their function **should** be located on the strip. Mobile objects **should not** be permitted above these surfaces during the use of the Runway for landing.

32. New objects or extensions of existing objects **should not** be permitted:

- a. Above an approach surface within 3000 m of the inner edge or above a transitional surface except when the new object or extension would be shielded by an existing immovable object.
- b. Above the conical surface, the inner horizontal surface ►or the outer horizontal surface◄ except when an object would be shielded by an existing immovable object, or after Safety Assessment, it is determined that the object would not adversely affect the Safety or significantly affect the regularity of operations of ►Aircraft.◄

33. Existing objects above an approach surface, a transitional surface, the conical surface and inner horizontal surface **should**, as far as practicable, be removed except when an object would be shielded by an existing immovable object, or after Safety Assessment, it is determined that the object would not adversely affect the Safety or significantly affect the regularity of operations of ►Aircraft.◄

**Guidance
Material
3512(5)**

Obstacle Limitation Surfaces Requirements - Precision Approach (Cat I) Runways

Civil Equivalence.

34. This Regulation is in line with ICAO Annex 14 Vol I para 4.2.

**Regulation
3512(6)****Obstacle Limitation Surfaces Requirements - Precision Approach
(Cat II / III) Runways**

3512(6) HoEs and ADH-Facing Organizations **shall** establish the following OLS for a Precision Approach Runway Category II or III; conical, inner horizontal, outer horizontal, take-off climb, approach and inner approach, transitional surfaces and inner transitional, and balked landing.

**Acceptable
Means of
Compliance
3512(6)****Obstacle Limitation Surfaces Requirements - Precision Approach
(Cat II / III) Runways**

35. The heights and slopes of the surfaces **should not** be greater than, and their other dimensions **should not** be less than, those specified in Annex A, except in the case of the horizontal section of the Approach surface (see below).
36. The approach surface **should** be horizontal beyond the point at which the 2.5% slope intersects the higher of:
- A horizontal plane 150 m above the threshold elevation; or
 - The horizontal plane passing through the top of any object that governs the obstacle clearance limit.
37. Fixed objects **should not** be permitted above the inner approach surface, the inner transitional surface or the balked landing surface, except for frangible objects which because of their function **should** be located on the strip. Mobile objects **should not** be permitted above these surfaces during the use of the Runway for landing.
38. New objects or extensions of existing objects **should not** be permitted above an approach surface within 3000 m of the inner edge or above a transitional surface except when the new object or extension would be shielded by an existing immovable object.
39. New objects or extensions of existing objects **should not** be permitted above the conical surface, the inner horizontal surface ► or the outer horizontal surface ◀ except when an object would be shielded by an existing immovable object, or after Safety Assessment, it is determined that the object would not adversely affect the Safety or significantly affect the regularity of operations of ► Aircraft. ◀
40. Existing objects above an approach surface, a transitional surface, the conical surface and inner horizontal surface **should**, as far as practicable, be removed except when an object would be shielded by an existing immovable object, or after Safety Assessment, it is determined that the object would not adversely affect the Safety or significantly affect the regularity of operations of ► Aircraft. ◀

**Guidance
Material
3512(6)****Obstacle Limitation Surfaces Requirements - Precision Approach
(Cat II / III) Runways****Civil Equivalence.**

41. This Regulation is in line with ICAO Annex 14 Vol I para 4.2.

**Regulation
3512(7)****Obstacle Limitation Surfaces Requirements - Runways Meant For
Take-Off**

3512(7) HoEs and ADH-Facing Organizations **shall** establish a take-off climb surface for a Runway meant for take-off.

**Acceptable
Means of
Compliance
3512(7)****Obstacle Limitation Surfaces Requirements - Runways Meant For
Take-Off**

42. The dimensions of the surface **should not** be less than the dimensions specified in Annex B, except that a lesser length may be adopted for the take-off climb

**Acceptable
Means of
Compliance
3512(7)**

surface where such lesser length would be consistent with procedural measures adopted to govern the outward flight of ► **Aircraft**. ◀

43. New objects or extensions of existing objects **should not** be permitted above a take-off climb surface except when the new object or extension would be shielded by an existing immovable object.

44. Existing objects that extend above a take-off climb surface **should**, as far as practicable, be removed except when an object is shielded by an existing immovable object, or after Safety Assessment it is determined that the object would not adversely affect the Safety or significantly affect the regularity of operations of ► **Aircraft**. ◀

**Guidance
Material
3512(7)**

Obstacle Limitation Surfaces Requirements - Runways Meant For Take-Off

Civil Equivalence.

45. This Regulation is in line with ICAO Annex 14 Vol I para 4.2.

**Regulation
3512(8)**

Objects Outside the Obstacle Limitation Surfaces

3512(8) HoEs and ADH-Facing Organizations **shall** ensure that proposed construction beyond the limits of the OLS are assessed where it may constitute a Hazard to ► **Aircraft**. ◀

**Acceptable
Means of
Compliance
3512(8)**

Objects Outside the Obstacle Limitation Surfaces

46. Construction outside the vertical or lateral limits of the OLS, which may constitute a Hazard to ► **Aircraft** ◀ **should** be assessed to determine whether operating limitations need to be applied.

47. Objects which extend to a height of 150 m or more above ground elevation **should** be regarded as obstacles, unless a special aeronautical study indicates that they do not constitute a Hazard to ► **Aircraft**. ◀

**Guidance
Material
3512(8)**

Objects Outside the Obstacle Limitation Surfaces

Civil Equivalence.

48. This Regulation is in line with ICAO Annex 14 Vol I para 4.3.

ANNEX A

Dimensions of slopes of obstacle limitation surfaces – Approach Runways

| Surface and dimensions ^a | Non-instrument | | | | Non-precision approach | | | Precision approach category | | |
|-------------------------------------|----------------|-------|-------|-------|------------------------|--------------------|--------------------|-----------------------------|--------------------|--------------------|
| | Code number | | | | Code number | | | I | II or III | |
| (1) | 2 | 3 | 4 | 5 | 6 | 7 | 8 | Code number | Code number | Code number |
| Surface and dimensions ^a | 1 | 2 | 3 | 4 | 1,2 | 3 | 4 | 1,2 | 3,4 | 3-4 |
| (1) | (2) | (3) | (4) | (5) | (6) | (7) | (8) | (9) | (10) | (11) |
| CONICAL | | | | | | | | | | |
| Slope (%) | 5 | 5 | 5 | 5 | 5 | 5 | 5 | 5 | 5 | 5 |
| Height (m) | 35 | 55 | 75 | 100 | 60 | 75 | 100 | 60 | 100 | 100 |
| INNER HORIZONTAL | | | | | | | | | | |
| Height (m) | 45 | 45 | 45 | 45 | 45 | 45 | 45 | 45 | 45 | 45 |
| Radius (m) | 2 000 | 2 500 | 4 000 | 4 000 | 3 500 | 4 000 | 4 000 | 3 500 | 4 000 | 4 000 |
| INNER APPROACH | | | | | | | | | | |
| Width | - | - | - | - | - | - | - | 90 | 120 ^e | 120 ^e |
| Distance from threshold | - | - | - | - | - | - | - | 60 | 60 | 60 |
| Length (m) | - | - | - | - | - | - | - | 900 | 900 | 900 |
| Slope (%) | - | - | - | - | - | - | - | 2.5 | 2 | 2 |
| APPROACH | | | | | | | | | | |
| Length of inner edge (m) | 60 | 80 | 150 | 150 | 150 | 280 | 280 | 140 | 280 | 280 |
| Distance from threshold (m) | 30 | 60 | 60 | 60 | 60 | 60 | 60 | 60 | 60 | 60 |
| Divergence (each side) (%) | 10 | 10 | 10 | 10 | 15 | 15 | 15 | 15 | 15 | 15 |
| First section | | | | | | | | | | |
| Length (m) | 1 600 | 2 500 | 3 000 | 3 000 | 2 500 | 3 000 | 3 000 | 3 000 | 3 000 | 3 000 |
| Slope (%) | 5 | 4 | 3.33 | 2.5 | 3.33 | 2 | 2 | 2.5 | 2 | 2 |
| Second Section | | | | | | | | | | |
| Length (m) | - | - | - | - | - | 3 600 ^b | 3 600 ^b | 12 000 | 3 600 ^b | 3 600 ^b |
| Slope (%) | - | - | - | - | - | 2.5 | 2.5 | 3 | 2.5 | 2.5 |
| Horizontal Section | | | | | | | | | | |
| Length (m) | - | - | - | - | - | 8 400 ^b | 8 400 ^b | - | 8 400 ^b | 8 400 ^b |
| Total length (m) | - | - | - | - | - | 15 000 | 15 000 | 15 000 | 15 000 | 15 000 |
| TRANSITIONAL | | | | | | | | | | |
| Slope (%) | 20 | 20 | 14.3 | 14.3 | 20 | 14.3 | 14.3 | 14.3 | 14.3 | 14.3 |
| INNER TRANSITIONAL | | | | | | | | | | |
| Slope (%) | - | - | - | - | - | - | - | 40 | 33.3 | 33.3 |
| BALKED LANDING SURFACE | | | | | | | | | | |
| Length of inner edge (m) | - | - | - | - | - | - | - | 90 | 120 ^e | 120 ^e |
| Distance from threshold (m) | - | - | - | - | - | - | - | c | 1 800 ^d | 1800 ^d |
| Divergence (each side) (%) | - | - | - | - | - | - | - | 10 | 10 | 10 |
| Slope (%) | - | - | - | - | - | - | - | 4 | 3.33 | 3.33 |

- a. All dimensions are measured horizontally unless specified otherwise.
- b. ▶ Variable length (see RA 3512(4) para 25, RA 3512(5) para 30, RA 3512(6) para 36). ◀
- c. Distance to the end of strip.
- d. Or end of Runway whichever is less.
- e. Where the code letter is F the width is increased to ▶ 140 m ◀. For information on code letter F ▶ Aircraft ◀ equipped with digital avionics that provide steering commands to maintain an established track during the go-around manoeuvre, see Circulars 301 ▶ and 345, and Chapter 4 of the PANS-Aerodromes, Part I (Doc 9981) for further information. ◀

ANNEX B

Dimensions of slopes of obstacle limitation surfaces – Runways Meant for Take-off

| Surface and dimensions ^a | Code number | | |
|---|-------------|--------|-------------------------------|
| | 1 | 2 | 3 or 4 |
| (1) | (2) | (3) | (4) |
| TAKE-OFF CLIMB | | | |
| Length of inner edge | 60 m | 80 m | 180 m |
| Distance from Runway end ^b | 30 m | 60 m | 60 m |
| Divergence (each side) | 10% | 10% | ▶12.5%◀ |
| Final width | 380 m | 580 m | 1200 m 1800 m ^c |
| Length | 1600 m | 2500 m | 15000 m |
| Slope | 5% | 4% | 2% ^d |
| a. All dimensions are measured horizontally unless specified otherwise. | | | |
| b. The take-off climb surface starts at the end of the clearway if the clearway length exceeds the specified distance. | | | |
| c. 1800 m when the intended track includes changes of heading greater than 15° for operations conducted in IMC, VMC by night. | | | |
| d. See 4.2.24 and 4.2.26. | | | |

Intentionally Blank for Print Pagination

RA 3513 - Permanent Fixed Wing Aerodrome - Indicators and Signalling Devices

Rationale

There are occasions when information is not available through radio communication. If the information is not otherwise available this would constitute a Hazard to **► Aircraft ◀**. Indicators and signalling devices are vitally important visual aids to assist with the safe operations at an Aerodrome.

Contents

- 3513(1): Wind Direction Indicator
- 3513(2): Landing Direction Indicator
- 3513(3): Aerodrome Identification from the air
- 3513(4): Signalling Lamp

Regulation

3513(1)

Wind Direction Indicator

3513(1) Heads of Establishments (HoEs) and Aviation Duty Holder-Facing Organizations (ADH-Facing Organizations) **shall** ensure that an Aerodrome is equipped with wind direction indicators to provide wind information to the pilot during approach and take-off.

Acceptable Means of Compliance

3513(1)

Wind Direction Indicator

1. Each wind direction indicator **should** be located so **►◀** at least one **►◀** is visible from **► Aircraft ◀** in flight, during approach or on the movement area before take-off, and in such a way as to be free from the effects of air disturbances caused by nearby objects.
2. Wind direction indicators **should**:
 - a. Be in the form of a truncated cone made of fabric;
 - b. Have a length of not less than 3.6 m and a diameter, at the larger end, of not less than 0.9 m;
 - c. Be constructed so that it gives a clear indication of the direction of the surface wind and a general indication of the wind speed;
 - d. Be of a colour or colours as to make the wind direction indicator clearly visible and understandable from a height of at least 300 m.
 - e. **►◀**
3. **► At least one illuminated wind direction indicator should be provided where there is a requirement for night flying, to provide Aircrew both in the air and on the ground with a clear indication of wind speed and direction. ◀**

Guidance Material

3513(1)

Wind Direction Indicator

4. A single colour may be used.
5. Where a combination of two colours is required to give adequate conspicuity against changing backgrounds, they may preferably be orange and white, red and white, or black and white, and may be arranged in five alternate bands, the first and last bands being the darker colour.

Civil Equivalence.

6. This Regulation is in line with International Civil Aviation Organization (ICAO) Annex 14 Vol I para 5.1.1.

**Regulation
3513(2)**
Landing Direction Indicator

3513(2) HoEs and ADH-Facing Organizations **shall** ensure that, where provided, a landing direction indicator is located in a conspicuous place on the Aerodrome.

**Acceptable
Means of
Compliance
3513(2)**
Landing Direction Indicator

7. The landing direction indicator **should**:
- Be in the form of a 'T';
 - Have the shape and minimum dimensions as shown in Figure 1.
 - Be either white or orange, the choice being dependent on the colour that contrasts best with the background against which the indicator is viewed; and
 - Either be illuminated or outlined by white light where used at night.

Figure 1. Landing Direction Indicator

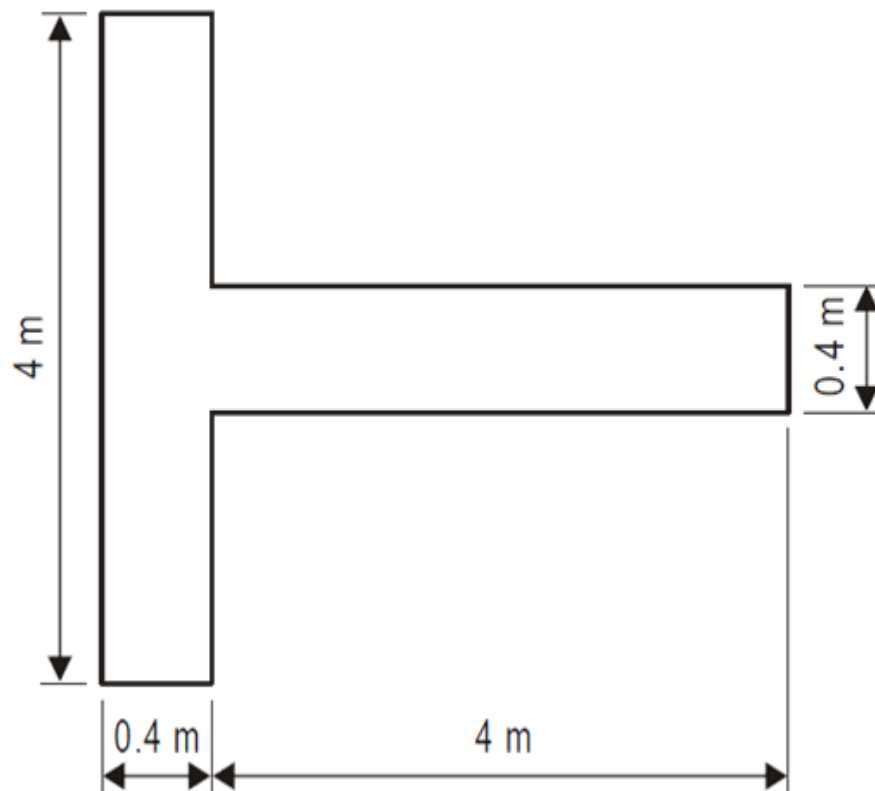
**Guidance
Material
3513(2)**
Landing Direction Indicator
Civil Equivalence.

8. This Regulation is in line with ICAO Annex 14 Vol I para 5.1.2.

**Regulation
3513(3)**
Aerodrome Identification from the air

3513(3) HoEs and ADH-Facing Organizations **shall** ensure that the Aerodrome is readily identifiable from the air.

**Acceptable
Means of
Compliance
3513(3)**

Aerodrome Identification ► from the air ◀

9. Where provided, the MOD airfield bigram identification **should** be displayed on the Aerodrome side of the Air Traffic Control (ATC) building visible from the air and in a position clear of buildings, but not on the Runway.
10. The letters **should** be 6 m by 3.6 m painted white on a black background.

**Guidance
Material
3513(3)**

Aerodrome Identification ► from the air ◀

11. Nil.

**Regulation
3513(4)**

Signalling Lamp

- 3513(4) HoEs and ADH-Facing Organizations **shall** ensure that a signalling lamp is provided in the Aerodrome control tower.

**Acceptable
Means of
Compliance
3513(4)**

Signalling Lamp

12. The signalling lamp **should**:
- Be capable of producing red, green and white signals;
 - Be capable of being aimed manually at any target as required;
 - Be capable of giving a signal in any one colour followed by a signal in either of the two other colours;
 - Have a beam spread not less than 1° or greater than 3°, with negligible light beyond 3°; and
 - When intended for use during the daytime, have a colour light intensity not less than 6000 cd.

**Guidance
Material
3513(4)**

Signalling Lamp

Civil Equivalence.

13. This Regulation is in line with ICAO Annex 14 Vol I para 5.1.3.

Intentionally Blank for Print Pagination

RA 3514 - Permanent Fixed Wing Aerodrome - Markings

Rationale

Movement around an aerodrome and understanding of an aerodrome layout is essential for safe operations. Any misunderstanding of the purpose of the various surfaces could prove hazardous to Air Systems or operators. To provide clarity and to enhance the safe movement of Air Systems at an aerodrome, markings are provided for clear and consistent information and guidance to the operating community.

Contents

- 3514(1): General Markings**
- 3514(2): Runway Markings**
- 3514(3): Aiming Point and Touchdown Zone Markings**
- 3514(4): Taxiway Markings**
- 3514(5): Vehicle Roadway Markings**
- 3514(6): Air System Stand Markings**
- 3514(7): Arrestor System Markings**
- 3514(8): Mandatory Instruction Markings**
- 3514(9): Information Markings**

Regulation

3514(1)

General Markings

3514(1) Heads of Establishments (HoEs) and Aviation Duty Holder - Facing Organizations (ADH-Facing Organizations) **shall** ensure that clearly defined markings are provided to allow safe movement within the aerodrome by vehicles and Air Systems.

Acceptable Means of Compliance 3514(1)

General Markings

1. Runway markings **should** be white.
2. Markings for taxiways, runway turn pads and Air System stands **should** be yellow.
3. Apron safety lines **should** be of a conspicuous colour which **should** contrast with that used for Air System stand markings.
4. Black outlining (at least 0.15 m in width) **should** be provided where there is insufficient background contrast.
5. At aerodromes where operations take place at night, pavement markings **should** be made with reflective materials designed to enhance the visibility of the markings.
6. At the intersection of two or more runways the markings of the more important runway **should** be displayed, and the markings of the other runways interrupted.
7. At the intersection of a runway and a taxiway the markings of the runway **should** be displayed, and the markings of the taxiway interrupted, except that runway side stripe may be interrupted.
8. Colour and discrimination requirements for all objects **should** be as detailed in International Civil Aviation Organization (ICAO) Annex 14, Vol I, Appendix 1.
9. All markings on paved runways **should** have friction values not less than the friction assessment Minimum Friction Level for the surrounding runway.
10. Markings on aprons and taxiways **should** be made with materials having similar wet friction qualities to those of the surrounding paved surfaces.

**Guidance
Material
3514(1)**

General Markings

11. At the intersection of two runways, the runway side stripe marking of the main runway may either be continued across the intersection or interrupted.
12. The order of importance of runways for the display of runway markings may be defined as follows:
 - a. 1st - precision approach runway;
 - b. 2nd - non-precision approach runway; and
 - c. 3rd - non-instrument runway.
13. Colour specifications for paints can be found in BS 381C and colour specifications for signs and surface markings are for reflective materials are prescribed in BS EN 12899-1:2007.
14. Requirements for the friction characteristics on a runway are detailed in RA 3590¹.

Civil Equivalence.

15. This regulation is in line with ICAO Annex 14 Vol I para 5.2.1.

**Regulation
3514(2)**

Runway Markings

- 3514(2) HoEs and ADH-Facing Organizations **shall** ensure that all paved runways are provided with markings for Runway Designation, Runway Centre-Line and Threshold.

**Acceptable
Means of
Compliance
3514(2)**

Runway Markings

16. Runway Designation Markings **should**:
 - a. Be located at a threshold as shown in Figure 1 as appropriate;
 - b. Consist of a two-digit number comprised of the whole number nearest the one-tenth of the magnetic North when viewed from the direction of approach (including a leading zero where the nearest one-tenth is less than 10);
 - c. On parallel runways, be supplemented with a letter (for two parallel runways: "L" "R" viewed from the direction of approach, for three parallel runways: "L" "C" "R" viewed from the direction of approach);
 - d. Be in the form and proportion, but not less than, those shown in Figure 2.
17. Runway Centre-Line Markings **should**:
 - a. Be located along the centre-line of the runway between the runway designation markings as shown in Figure 3, except when interrupted in compliance with RA 3519²;
 - b. Consist of a line of uniformly spaced stripes and gaps. The length of a stripe plus a gap **should** be not less than 50 m or more than 75 m;
 - c. The length of each stripe **should** be at least equal to the length of the gap or 30 m, whichever is greater; and
 - d. Have a width no less than:
 - (1) 0.90 m on precision approach category II and III runways;
 - (2) 0.45 m on non-precision approach runways where the code number is 3 or 4, and precision approach category I runways; and
 - (3) 0.30 m on non-precision approach runways where the code number is 1 or 2, and on non-instrument runways.
18. Threshold Markings **should**:

¹ Refer to RA 3590 – Maintenance and Safeguarding.

² Refer to RA 3519 – Permanent Fixed Wing Aerodrome - Visual Aids for Denoting Restricted Use Areas.

**Acceptable
Means of
Compliance
3514(2)**

- a. Have its longitudinal stripes commenced 6 m from the threshold.
 - b. Consist of a pattern of longitudinal stripes of uniform dimensions disposed symmetrically about the centre-line of the runway as shown in Figure 1 for a runway of width 45 m.
 - c. Have stripes extending laterally to within 3 m of the edge of the runway; or to 27 m on either side of a runway centre line, whichever results in the smaller lateral distance.
 - d. Have numbers in accordance with (iaw) Table 1; and
 - e. Have a Transverse Stripe with a minimum width of 1.8 m if the extremity of the runway is not square with the runway centre-line or as shown in Figure 4.
19. Permanently displaced runway thresholds **should**:
- a. Be marked as shown in Figure 1: 2(i) and 2(ii);
 - b. Have a Transverse Stripe, with a minimum width of 1.8 m, provided as per Figure 4 (the outer edge of the Transverse Stripe indicates the displaced threshold location)
 - c. Have all markings prior to the displaced threshold obscured except the runway centre-line marking, which **should** be converted to arrows.
20. Temporarily displaced runway thresholds **should**:
- a. Be marked as shown in Figure 1: 3(i) and 3(ii).
 - b. Have all markings prior to the displaced threshold obscured except the runway centre-line marking, which **should** be converted to arrows;
 - c. Have the runway centre-line markings prior to the displaced threshold turned into arrows; and
 - d. Be marked iaw RA 3519, if the runway before the displaced threshold is unfit for the surface movement of Air Systems.
21. Runway Side Stripe Markings **should**:
- a. Be provided between the thresholds of a paved runway where:
 - (1) The width of the runway is greater than 45 m wide; or
 - (2) There is a lack of contrast between the runway edges and the shoulders or surrounding terrain; or
 - (3) The runway is served by a precision approach aid.
 - b. Consist of two parallel lines, one placed along each edge of the runway with the outer edge of each line marking the declared edge of the runway; except that, where the runway is greater than 60 m in width, the stripes **should** be located 30 m from the runway centre-line;
 - c. Be 0.9 m wide where the runway is 30 m or more in width and 0.45 m wide on narrower runways;
22. At an intersection of two or more runways the markings of the main runway, except for the runway side stripe marking, **should** be displayed and the markings of the other runways, interrupted. The runway side stripe marking of the more important runway may be either continued across the intersection or interrupted.

Acceptable Means of Compliance 3514(2)

Figure 1. Precision Approach Runways

| Type of threshold | Precision instrument approach runways | |
|-------------------|---------------------------------------|---|
| 1 | | |
| 2(i) | | <p>Key:</p> <ul style="list-style-type: none"> 1 Not displaced. 2 Permanently displaced or temporarily displaced for more than six months. <ul style="list-style-type: none"> (i) Pre-threshold area of runway fit for movement of aircraft. (ii) Pre-threshold area of runway unfit for movement of aircraft and unsuitable as stopway. (iii) Pre-threshold area of runway fit for use by aircraft as a stopway, but not for normal movement of aircraft. 3 Temporarily displaced for six months or less. (Runway designator is NOT moved.) <ul style="list-style-type: none"> (i) Pre-threshold area of runway fit for movement of aircraft. (ii) Pre-threshold area of runway unfit for movement of aircraft. |
| 2(ii) | | |
| 2(iii) | | |
| 3(i) | | |
| 3(ii) | | |

Acceptable Means of Compliance 3514(2)

Figure 2. Character Dimensions

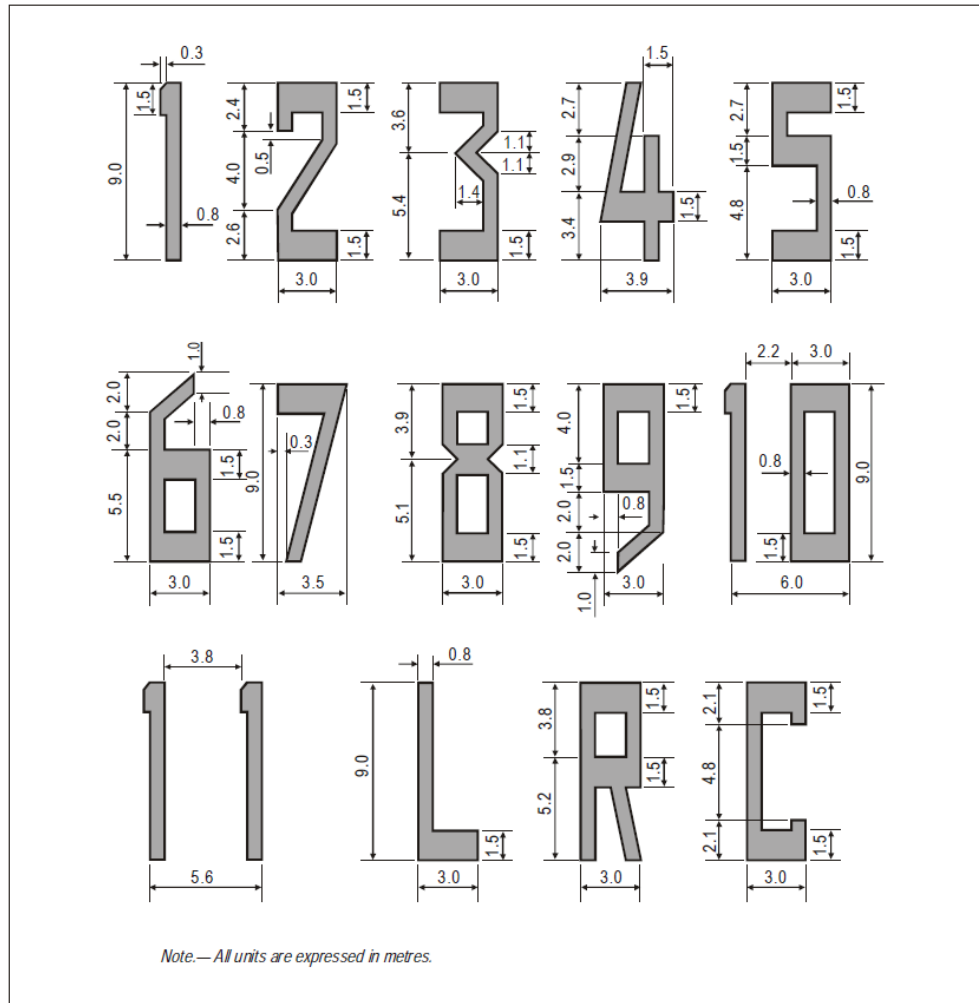
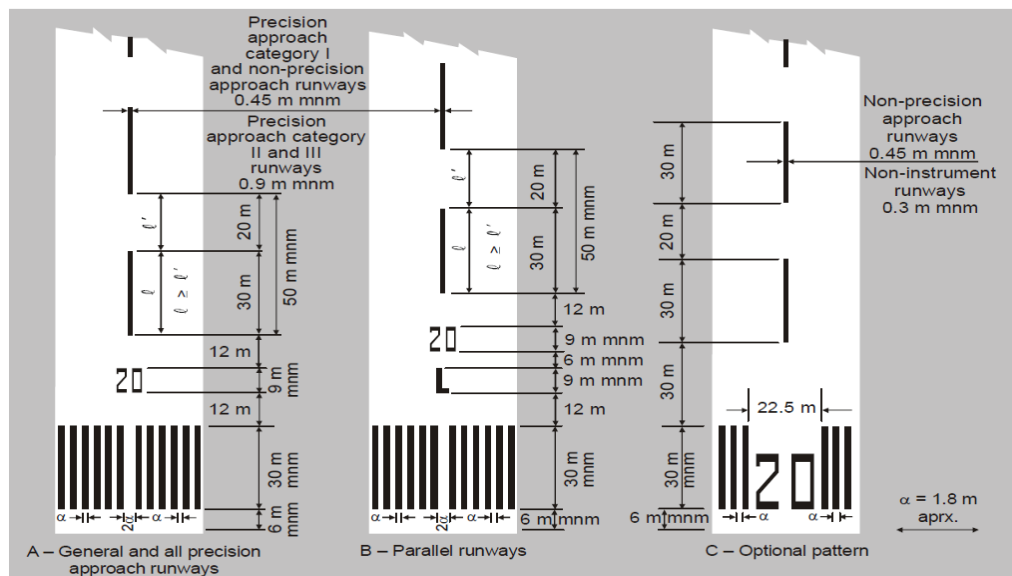

Figure 3. Runway designation, centre-line and threshold markings



Acceptable Means of Compliance 3514(2)

Figure 4. Displaced threshold markings

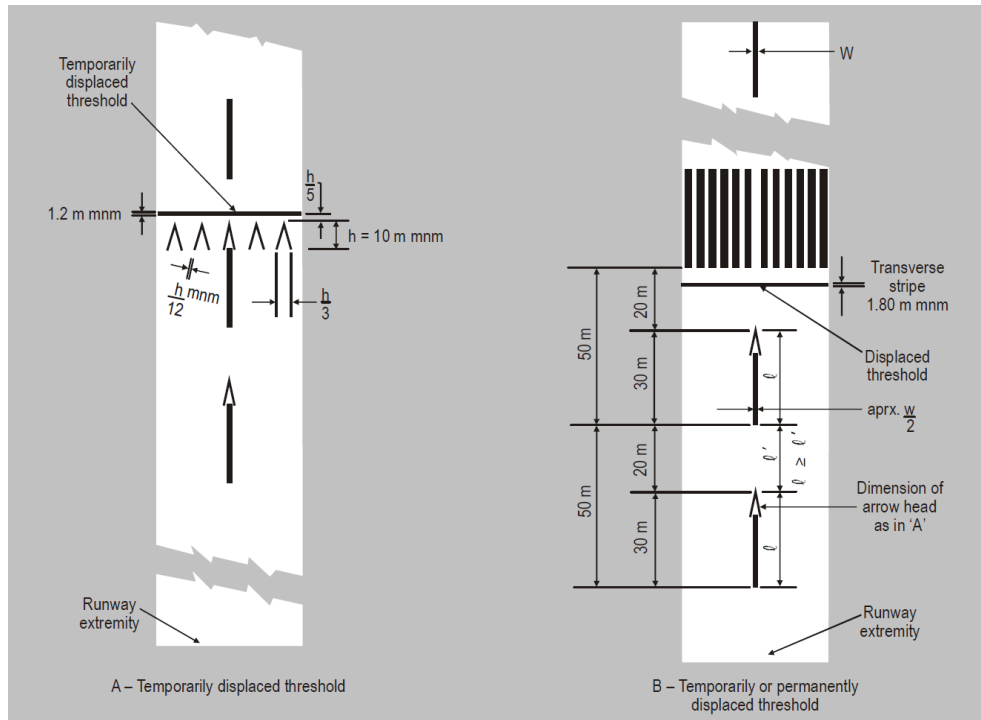

Table 1. Threshold Marking Stripes

| Runway width | Number of stripes |
|--------------|-------------------|
| 18 m | 4 |
| 23 m | 6 |
| 30 m | 8 |
| 45 m | 12 |
| 60 m | 16 |

Guidance Material 3514(2)

Runway Markings

23. Where edge light units are located along the extremity of the declared runway width, the runway strip markings may be located inboard of the edge light units to avoid painting the light units.

24. Edge light units may be placed along the edge of the load-bearing pavement, with the outer edge of the marking approximately on the edge of the load-bearing pavement.

Civil Equivalence.

25. This regulation is in line with ICAO Annex 14 Vol I para 5.2.2. – 5.2.4.

Regulation 3514(3)

Aiming Point and Touchdown Zone Markings

3514(3) HoEs and ADH-Facing Organizations **shall** ensure that Aiming Point Markings are provided on a paved instrument runway where code number is 2 - 6; and Touchdown Zone Markings are provided on a paved precision runway where the code number is 2 - 6.

**Acceptable
Means of
Compliance
3514(3)**

Aiming Point and Touchdown Zone Markings

26. Aiming Point Markings **should**:
- Be symmetrically disposed about the runway centre-line;
 - Have stripes and lateral spacing as described in Figure 5; and
 - Be placed at a point no closer to the threshold than the distance indicated in Table 2, except that, on a runway equipped with a visual slope indicator system, the beginning of the markings **should** be coincident with the visual slope origin.
27. Touchdown Zone Markings **should**:
- Consist of pairs of rectangular markings symmetrically disposed about the runway centre-line, **either pattern shown in Figure 5 is acceptable. For the pattern shown in Figure 5 (A), the markings should not be less than 22.5 m long and 3 m wide. For the pattern shown in Figure 5 (B), each stripe of each marking should be not less than 22.5 m long and 1.8 m wide with a spacing of 1.5 m between adjacent stripes.**
 - Have a number of pairs related to the landing distance available, **shown in Table 3 and, the pairs of markings should be provided at longitudinal spacings of 150 m beginning from the threshold, except that pairs of touchdown zone markings coincident with or located within 50 m of an aiming point marking should be deleted from the pattern.**
 - Have lateral spacing between the inner sides of stripes as for the Aiming Point marking as per Figure 5 and Table 2.
28. Where Aiming Point and Touchdown Zone Markings are not provided, their absence **should** be clearly communicated in relevant aeronautical information publications and the Defence Aerodrome Manual.

Figure 5. Touchdown Zone Markings

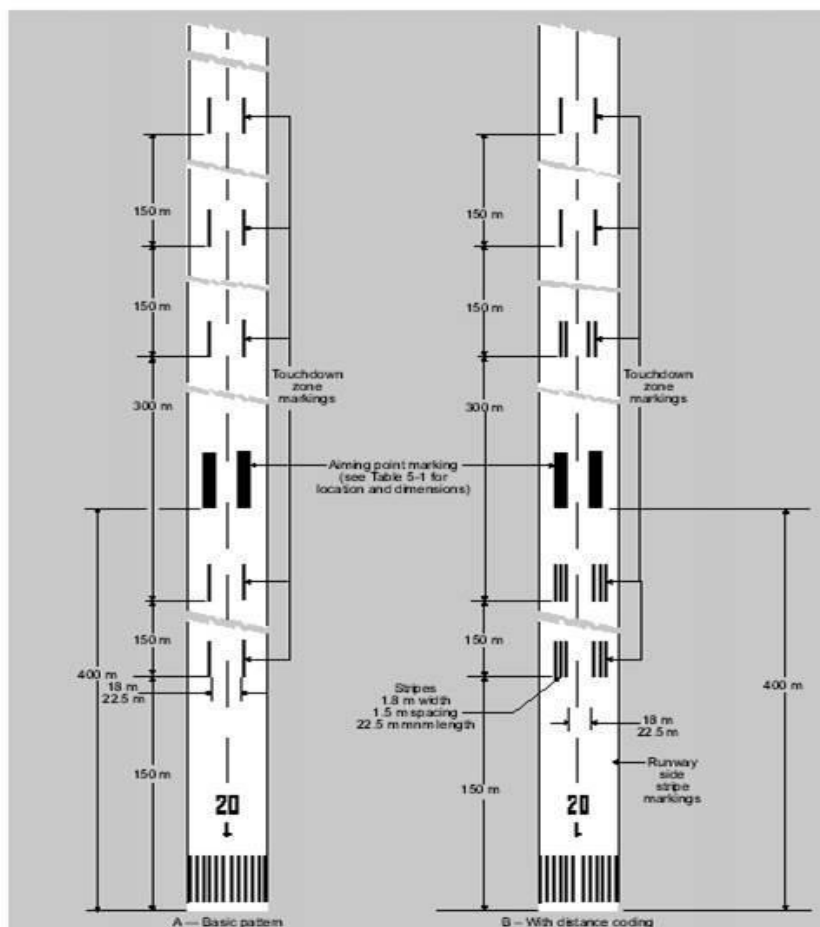

**Acceptable
Means of
Compliance
3514(3)**

► *Table 2. Location and Dimensions of Aiming Point Marking*

| Location and dimensions | Landing Distance Available | | | |
|---|----------------------------|----------------|-----------------------|-----------------------|
| | Less than 800 m | 800 m – 1199 m | 1200 m – 2399 m | 2400 m and above |
| Distance from threshold to beginning of marking | 150 m | 250 m | 300 m | 400 m |
| Length of stripe ^a | 30 - 45 m | 30 - 45 m | 45 – 60 m | 45 – 60 m |
| Width of stripe ^c | 4 m | 6 m | 6 – 10 m ^b | 6 – 10 m ^b |
| Lateral spacing between inner sides of stripes ^c | 6 m | 9 m | 18 – 22.5 m | 18 - 22.5 m |
| <p>^a The greater dimensions of the specified ranges are intended to be used where increased conspicuity is required.</p> <p>^b The lateral spacing may be varied within these limits to minimize the contamination of the marking by rubber deposits.</p> <p>^c Where a runway is less than 45 m wide the parameters for width and lateral spacing should be discussed and agreed with Defence Infrastructure Organisation and the MAA as appropriate iaw RA 3500(1)³.</p> | | | | |

Table 3. Numbers of Pairs of Touchdown Zone Markings

| Landing Distance Available or the distance between thresholds | Pair(s) of markings |
|--|---------------------|
| < 900 m | 1 |
| 900 – 1199 | 2 |
| 1200 – 1499 | 3 |
| 1500 – 2399 | 4 |
| > 2400 m | 6 ^a |
| <p>^a Aiming Point Markings may be considered as 1 of the pairs in the painting pattern. ◀</p> | |

29. ►◀

**Guidance
Material
3514(3)**

Aiming Point and Touchdown Zone Markings

30. Aiming Point and Touchdown Zone markings constitute large areas of painted surface and therefore reduced friction characteristics, which may be assessed to present a hazard to some Air System operations.

31. Aiming Point and Touchdown Zone Markings may be omitted where it is assessed that Risk to Life will be increased by their presence.

Civil Equivalence.

32. This regulation is in line with ICAO Annex 14 Vol I para 5.2.5. and 5.2.6.

³ ► Refer to RA 3500(1): Aerodrome Design and Safeguarding, GM Para 12. ◀

**Regulation
3514(4)**

Taxiway Markings

3514(4) HoEs and ADH-Facing Organizations **shall** ensure that Taxiway Markings are provided on paved taxiways, de-icing / anti-icing facilities, turn pads and aprons to provide continuous guidance between the runway centre line and Air System stand.

**Acceptable
Means of
Compliance
3514(4)**

Taxiway Markings

33. Taxiway centre-line markings **should**:
- a. Be at least 0.15 m in width and of continuous length except where detailed in sub-paras b to h, or where:
 - (1) It intersects with a runway-holding position marking; or
 - (2) It intersects with an intermediate holding position marking.
 - b. On a straight section of taxiway, be located along the taxiway centre-line;
 - c. On a taxiway curve, continue from the straight portion of the taxiway at a constant distance from the outside edge of the curve;
 - d. Be placed along the edge of the load-bearing pavement, with the outer edge of the marking approximately on the edge of the load-bearing pavement;
 - e. Be discontinued at the edge of the runway if leading to a runway threshold;
 - f. Be broken at a distance of 1.5 m from the threshold or runway designation markings when the taxiway centre-line marking crosses the threshold or runway designation markings;
 - g. Be extended parallel to the runway centre-line marking for a distance of at least 60 m beyond the point of tangency where the code number is 3 or above and for a distance of at least 30 m where the code number is 1 or 2;
 - h. Be provided on a paved runway when:
 - (1) The runway is part of a standard taxi-route and there is no runway centre-line marking; or
 - (2) The taxiway centre-line is not coincident with the runway centre-line.
34. Taxiway side stripe markings **should**:
- a. Be provided if:
 - (1) It is necessary to define the outer edges of a taxiway; or
 - (2) A paved taxiway shoulder has insufficient bearing strength; or
 - (3) There is little contrast between the taxiway and the surrounding area.
 - b. Consist of a pair of solid lines, each 0.15 m wide and spaced 0.15 m apart;
 - c. Be the same colour as the taxiway centre-line marking; and
 - d. Be so positioned that the inner edge of the marking represents the outer edge of the taxiway.
35. Runway turn pad markings **should**:
- a. Be curved from the runway centre line into the turn pad. The radius of the curve **should** be compatible with the manoeuvring capability and normal taxiing speeds of the Air Systems for which the runway turn pad is intended. The intersection angle of the runway turn pad marking with the runway centre line **should not** be greater than 30 degrees.
 - b. Be extended parallel to the runway centre line marking for a distance of at least 60 m beyond the point of tangency where the code number is 3 to 6, and for a distance of at least 30 m where the code number is 1 or 2.

**Acceptable
Means of
Compliance
3514(4)**

- c. Guide the Air System in such a way as to allow a straight portion of taxiing before the point where a 180-degree turn is to be made. The straight portion of the runway turn pad marking **should** be parallel to the outer edge of the runway turn pad.
- d. Be at least 15 cm in width and continuous in length.
36. The design of the curve allowing the Air System to negotiate a 180-degree turn **should** be based on a nose wheel steering angle not exceeding 45 degrees.
37. The design of the turn pad marking **should** be such that, when the cockpit of the Air System remains over the runway turn pad marking, the clearance distance between any wheel of the Air System landing gear and the edge of the runway turn pad **should** be not less than those specified in ICAO Annex 14 para 3.3.6.
38. Runway holding position markings **should**:
- Be established iaw RA 3511(6)⁴, on each taxiway serving a runway;
 - Be marked iaw Figure 6, Pattern A for the runway-holding position closest to the runway;
 - Be marked iaw Figure 6, Pattern B for the runway-holding positions where provided on the same taxiway but farther from the runway;
 - Be positioned at right angles to the taxiway centre-line marking;
 - Be perpendicular to the centre-line of the runway forming part of the standard taxi-route. The pattern of the marking **should** be as shown in Figure 6, pattern A; and
 - Be displayed at a runway / runway intersection, perpendicular to the centre-line of the runway forming part of the standard taxi-route and iaw Figure 6.

Figure 6. Holding Position Patterns

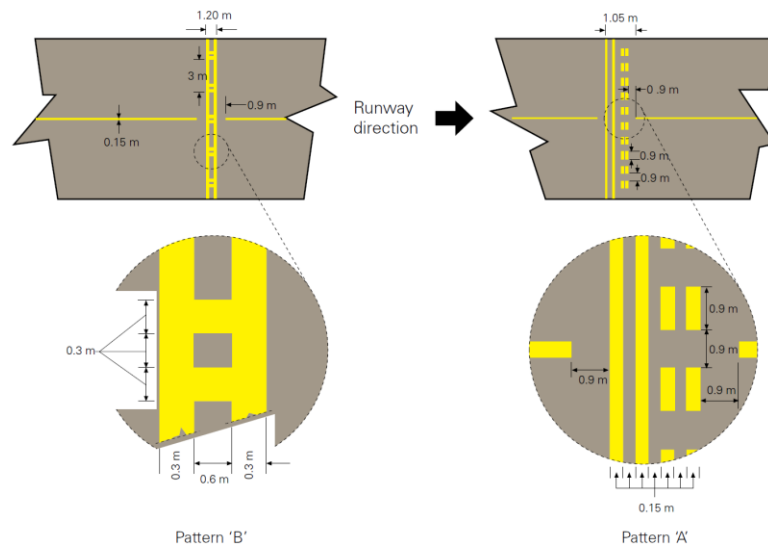

39. Intermediate holding position markings **should**:
- Be displayed along an intermediate holding position;
 - Be displayed at the exit boundary of a remote de-icing / anti-icing facility adjoining a taxiway;
 - Where located at the intersection of 2 paved taxiways, be located across the taxiway at sufficient distance from the near edge of the intersecting taxiway to ensure safe clearance between taxiing Air Systems; and
 - Consist of a single broken line as shown in Figure 7.

⁴ Refer to RA 3511(6): Taxiway - Characteristics.

Acceptable Means of Compliance 3514(4)

Figure 7. Intermediate Holding Position Marking

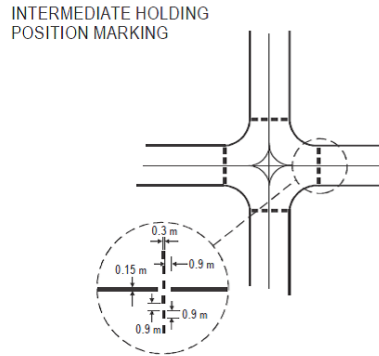

Guidance Material 3514(4)

Taxiway Markings

40. Enhanced taxiway centre-line marking may be provided to denote the proximity of a runway holding position. The provision of enhanced taxiway centre-line marking may form part of runway incursion prevention measures.

41. Enhanced taxiway centre-line marking may be as shown in Figure 8.

Civil Equivalence.

42. This regulation is in line with ICAO Annex 14 Vol I para 5.2.8, 5.8.10 and 5.8.11.

Figure 8. Enhanced Taxiway centre line marking

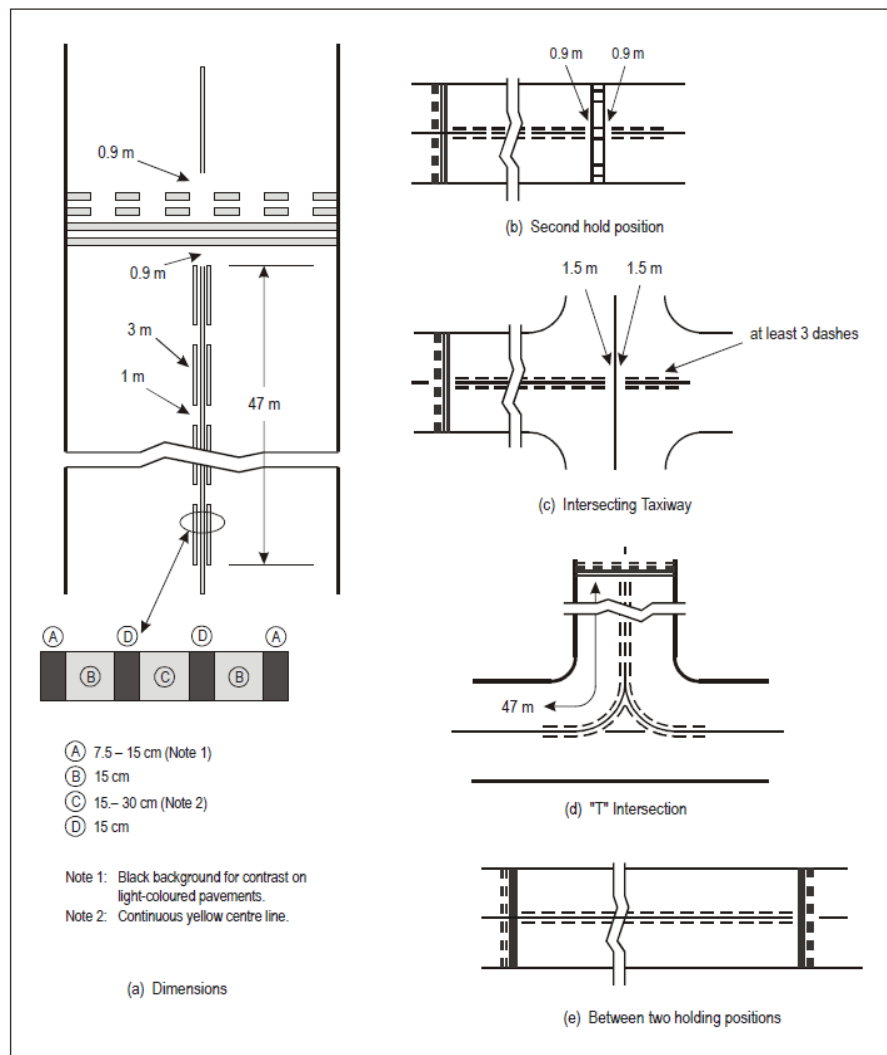

**Regulation
3514(5)**

Vehicle Roadway Markings

3514(5) HoEs and ADH-Facing Organizations **shall** ensure that vehicle roadway markings are used to delineate roadways located on areas that are also intended for use by Air Systems.

**Acceptable
Means of
Compliance
3514(5)**

Vehicle Roadway Markings

43. Vehicle roadway markings **should**:
- Be white in colour;
 - Consist of a solid line 0.15 m wide to delineate the edges of the roadway and a broken line 0.15 m wide and 4.5 m long at 7.5 m intervals to separate lanes within the edges of the roadway as shown in Figure 9;
 - Maintain a minimum spacing of 0.75 m between the roadway edge marking and the non-movement area boundary / boundary marking; and
 - Be interrupted by taxiway markings where a roadway and taxiway intersect.

Figure 9. Vehicle Roadway Markings

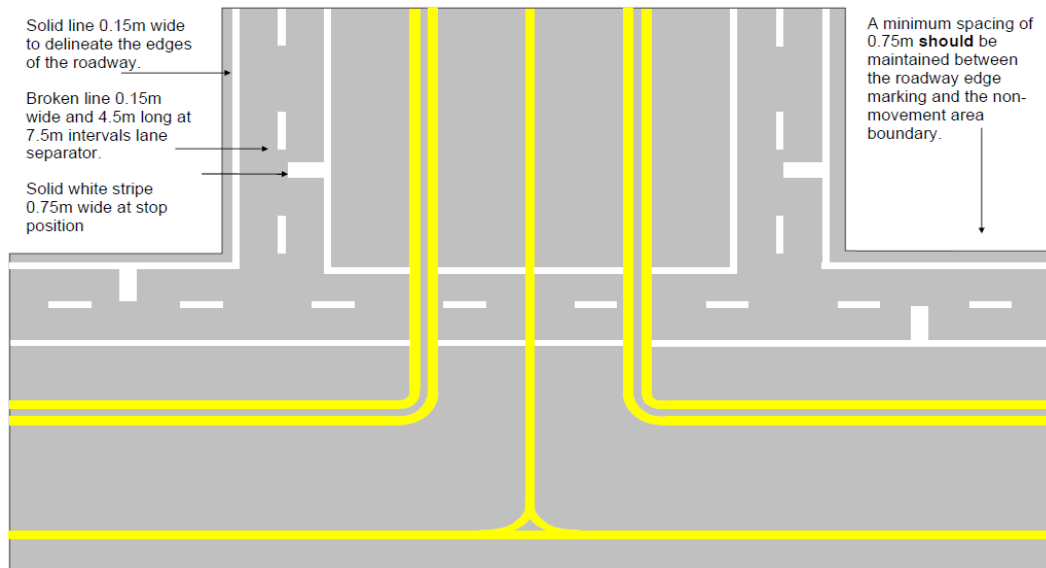

44. Road holding position markings **should**⁵:
- Be located across the road at the holding position; and
 - Where a road intersects a taxiway, be located across the road at the appropriate distance to ensure vehicles remain clear of the taxiway strip;
 - Be in accordance with the local road traffic regulations for a yield right of way.
45. The usage of runway ahead markings **should** be considered, as shown in Figures 10 and 11. Where possible, the runway ahead marking **should** be located before the mandatory marking and collocated with the CAT II / III holding position marking where applicable. Runway ahead marking sizes and proportions **should** be determined by local conditions; however, any markings **should** be legible to both Air Systems and vehicles.
46. Vehicle Roadway Markings placed on a taxiway or pavement surface **should not** create confusion with taxiway or runway markings for aircraft operation.

⁵ Refer to RA 3511 - Permanent Fixed Wing Aerodrome – Physical Characteristics for separation distances from runways.

Acceptable Means of Compliance 3514(5)

Figure 10. Runway Ahead Markings

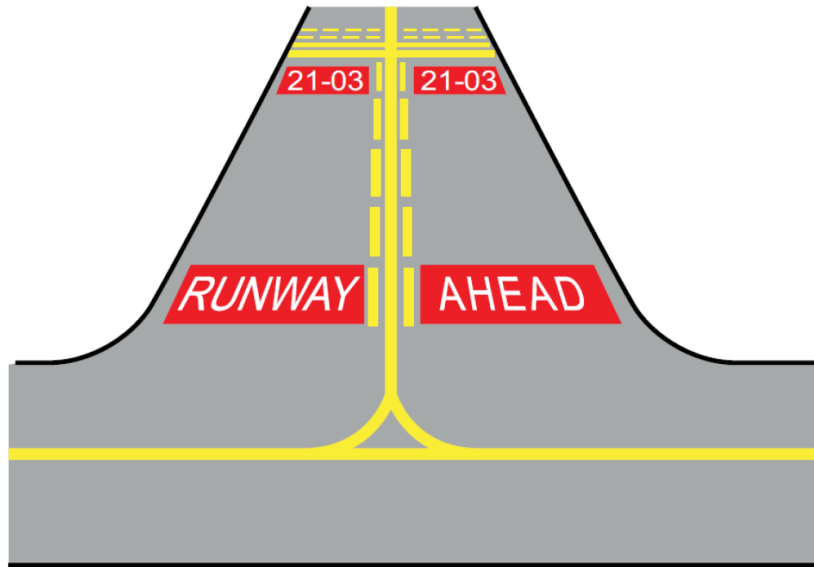
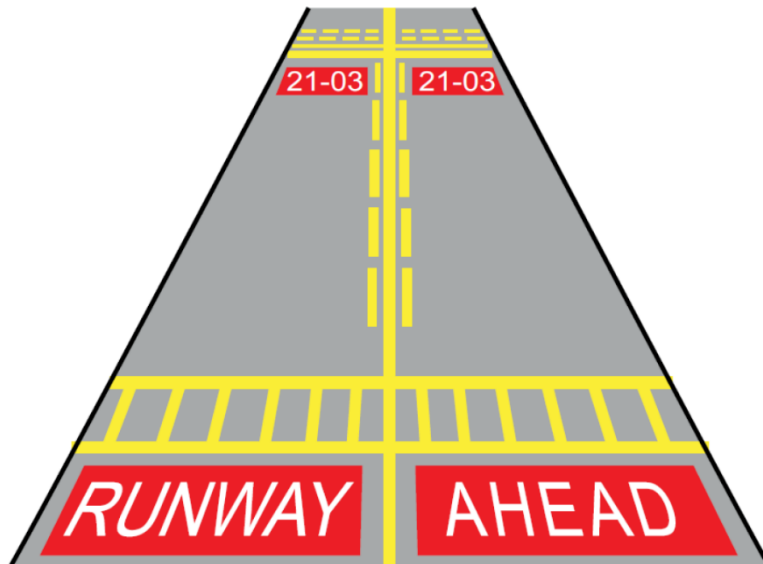

Figure 11. Runway Ahead Markings



Guidance Material 3514(5)

Vehicle Roadway Markings
Civil Equivalence.

47. This regulation is in line with ICAO Annex 14 Vol I para 5.2.15.

Regulation 3514(6)

Air System Stand Markings

3514(6) HoEs and ADH-Facing Organizations **shall** ensure that Air System stand markings are provided for designated parking positions on a paved apron.

**Acceptable
Means of
Compliance
3514(6)****Air System Stand Markings**

48. It is recommended that an Air System stand marking **should**:
- Be included in the lead-in line a short distance after the beginning of the lead-in line;
 - Be of an adequate height to be readable from the cockpit of Air Systems using the stand; and
 - Have the identification of the Air System for which each set of markings is intended added to the stand identification where two sets of Air System stand markings are superimposed on each other.
49. Lead in, turning and lead-out lines **should**:
- Be continuous in length and have a width of not less than 15 cm;
 - Where one or more sets of stand markings are superimposed on a stand marking, be continuous for the most demanding Air System and broken for other Air Systems;
 - For the curved portions of lead-in, turning, and lead-out lines, have radii appropriate to the most demanding Air System type for which the markings are intended; and
 - Where it is intended that an Air System proceeds in one direction only, have arrows pointing in the direction to be followed added as part of the lead-in and lead-out lines.
50. Alignment bars **should**:
- Be placed to be coincident with the extended centre-line of the Air System in the specified parking position and visible to the pilot during the final part of the parking manoeuvre; and
 - Have a width of not less than 15 cm.
51. Turn bars **should**:
- Be located at right angles to the lead-in line, abeam the left pilot position at the point of initiation of any intended turn;
 - Have a length and width of not less than 6 m and 15 cm respectively, and include an arrowhead to indicate the direction of turn; and
 - Where more than one turn bar is required, be designated for the appropriate Air System types.
52. Stop lines **should**:
- Be located at right angles to the alignment bar, abeam the left pilot position at the intended point of stop;
 - Have a length and width of not less than 6 m and 15 cm respectively; and
 - Where more than one stop line is required, be designated for the appropriate Air System types.
53. Apron safety lines **should**:
- Be located to define the areas intended for use by ground vehicles and other Air System servicing equipment to provide safe separation from Air Systems;
 - Include such elements as wing tip clearance lines and service road boundary lines as required by the parking configurations and ground facilities;
 - Be of a conspicuous colour which **should** contrast with that used for Air System stand markings; and
 - Be continuous in length and at least 10 cm in width.
54. Where provided, an Air System safe heading marking **should**:
- Identify a safe directional heading for armed Air Systems;

Acceptable Means of Compliance 3514(6)

- b. Be an arrow, in aviation yellow, conforming to Figure 12 and
- c. Have the heading, in degrees true, shown in aviation yellow adjacent to the arrow head and followed by the letter 'T'.

Figure 12. Air System Heading Marking

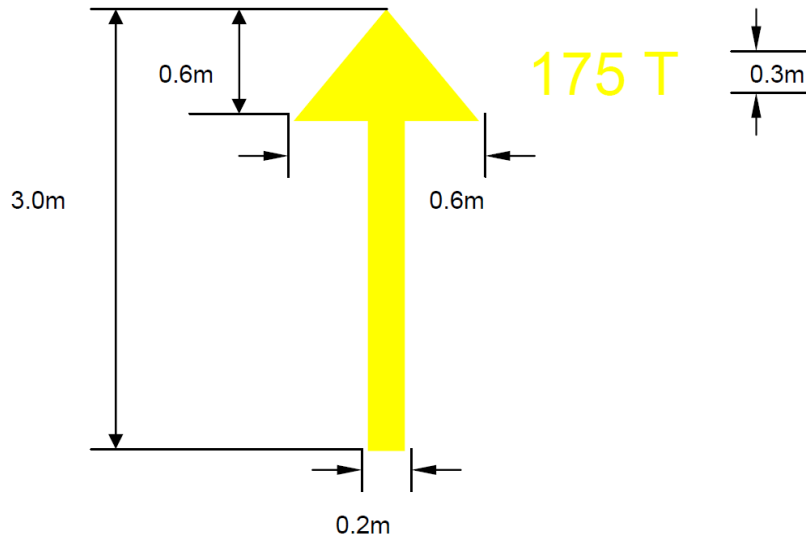

Guidance Material 3514(6)

Air System Stand Markings Civil Equivalence.

- 55. This regulation is in line with ICAO Annex 14 Vol I para 5.2.13 and 5.2.14.

Regulation 3514(7)

Arrestor System Markings

- 3514(7) HoEs and ADH-Facing Organizations **shall** ensure that when an Air System arresting system cable (or tape) is installed on a paved operational runway surface, its location is marked.

Acceptable Means of Compliance 3514(7)

Arrestor System Markings

- 56. Air System arrestor system markings **should** be a series of discs, in aviation yellow, along the line of the pendant cable across the width of the full runway conforming to Figure 13.
- 57. The disks **should** be 3 m in diameter and spaced at 7.5 m between centres, arranged in two groups symmetrically disposed about the runway centre-line with the innermost disc in each group located 3.75 m from the runway centre.

Figure 13. Arrestor System Markings

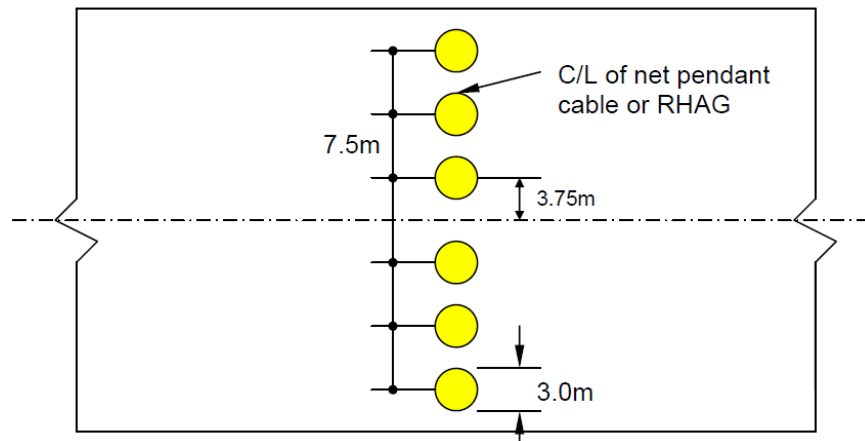

**Guidance
Material
3514(7)**

Arrestor System Markings

58. Nil.

**Regulation
3514(8)**

Mandatory Instruction Markings

3514(8) HoEs and ADH-Facing Organizations **shall** ensure that where it is impracticable to install a mandatory instruction sign iaw RA 3516⁶, or the taxiway width exceeds 60 m, a mandatory instruction marking is displayed on the surface of the pavement.

**Acceptable
Means of
Compliance
3514(8)**

Mandatory Instruction Markings

59. The mandatory instruction marking on taxiways, where the code letter is A, B, C, or D, **should**:

- a. Be located across the taxiway equally placed about the taxiway centre-line and on the holding side of the runway holding position marking as shown in Figure 14; and
- b. Have the nearest edge of the marking not less than 1 m from the runway holding position marking or the taxiway centre-line marking.

60. The mandatory instruction marking on taxiways, where the code letter is E, or F, **should**:

- a. Be located on the both sides of the taxiway centre-line marking and on the holding side of the runway-holding position marking as shown in Figure 14; and
- b. Have the nearest edge of the marking not less than 1 m from the runway holding position marking or the taxiway centre-line marking.

Figure 14. Mandatory Instruction Markings

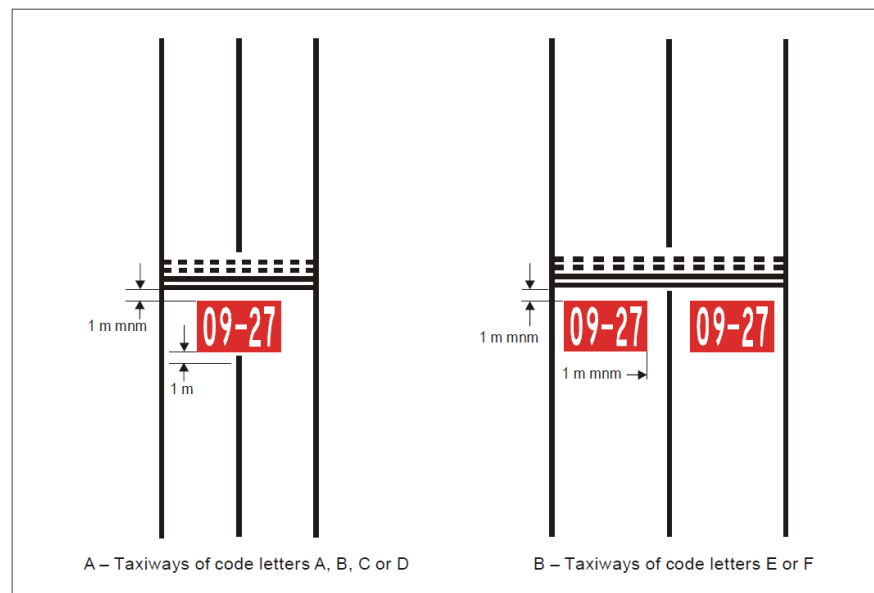

61. A mandatory instruction marking **should** consist of an inscription in white on a red background. Except for a NO ENTRY marking, the inscription **should** provide information identical to that of the associated mandatory instruction sign.

62. Where operationally required, such as on taxiways exceeding 60 m in width, or to assist in the prevention of a runway incursion, a mandatory instruction sign **should** be supplemented by a mandatory instruction marking.

⁶ Refer to RA 3516 – Permanent Fixed Wing Aerodrome - Signs.

**Acceptable
Means of
Compliance
3514(8)**

63. A NO ENTRY marking **should** consist of an inscription in white reading NO ENTRY on a red background.
64. The character height **should** be:
- 4 m for inscriptions where the code letter is C, D, E, or F;
 - 2 m where the code letter is A or B; and
 - In the form and proportions shown in Figure 15.
65. Where there is insufficient contrast between the marking and the pavement surface, the mandatory instruction marking **should** include an appropriate border, preferably white or black.
66. The background **should** be rectangular and extend a minimum of 0.5 m laterally and vertically beyond the extremities of the inscription.
67. Except where operationally necessary mandatory instructions **should not** be used on runways.
68. Markers **should** be used to delineate an unserviceable portion of the manoeuvring area.

Figure 15a. Character Form

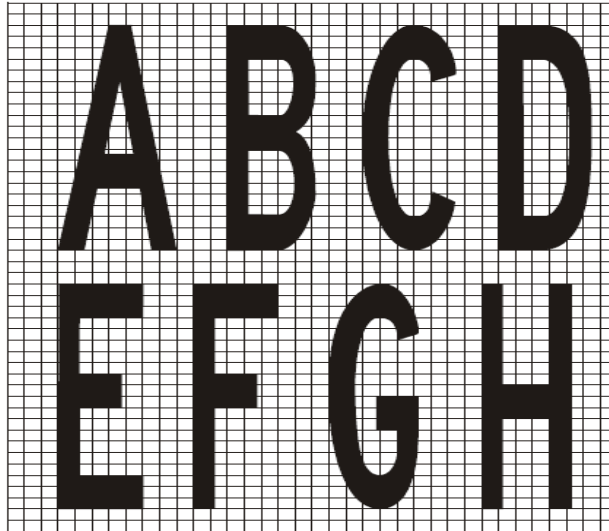
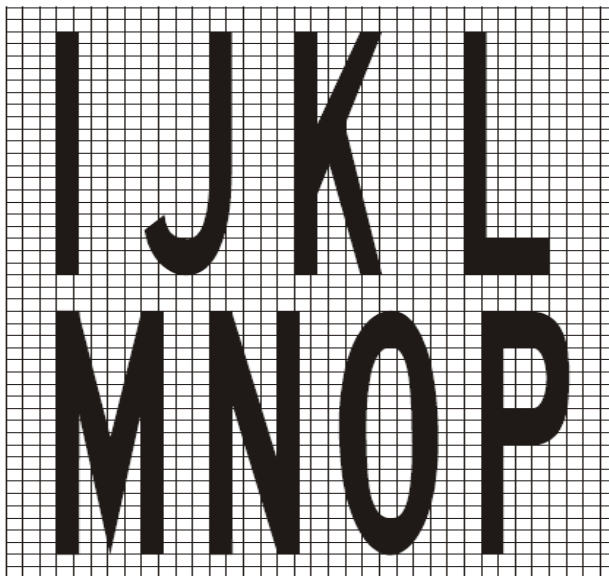

Figure 15b. Character Form



Acceptable
Means of
Compliance
3514(8)

Figure 15c. Character Form

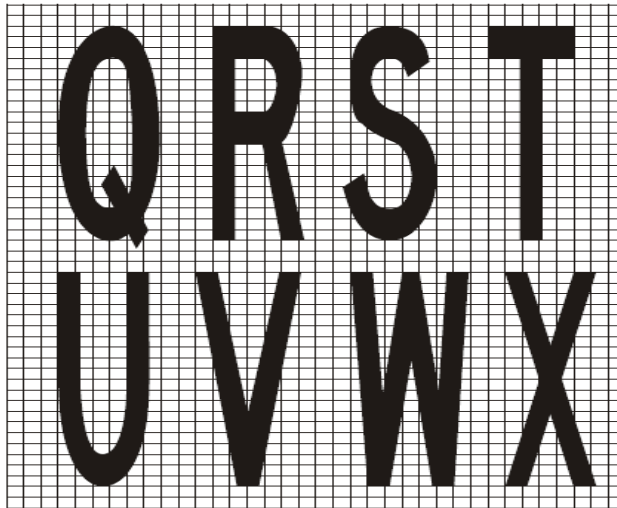

Figure 15d. Character Form

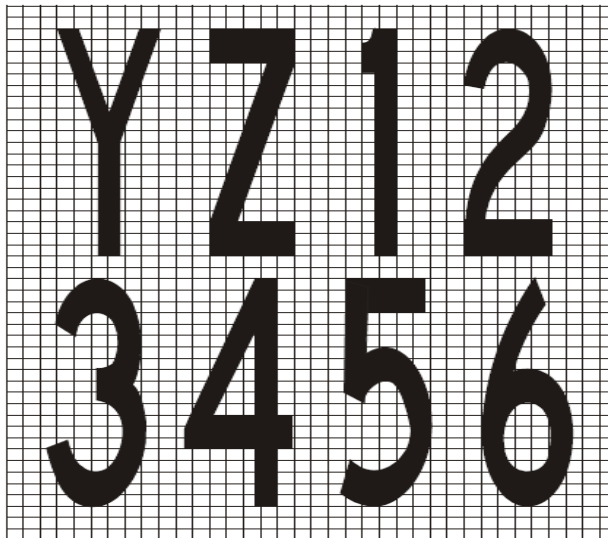
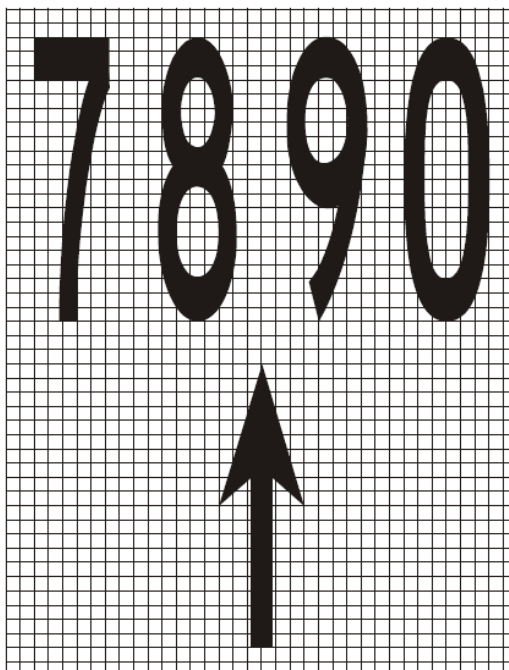

Figure 15e. Character Form



**Guidance
Material
3514(8)**

Mandatory Instruction Markings

Civil Equivalence.

69. This regulation is in line with ICAO Annex 14 Vol I para 5.2.16.

**Regulation
3514(9)**

Information Markings

3514(9) HoEs and ADH-Facing Organizations **shall** ensure that where it is not practicable to install an information sign iaw RA 3516⁶, an information marking is displayed on the surface of the pavement.

**Acceptable
Means of
Compliance
3514(9)**

Information Markings

70. An information marking **should**:

- a. Consist of an inscription in yellow upon a black background when it replaces or supplements a location sign;
- b. Consist of an inscription in black upon a yellow background when it replaces or supplements a direction or destination sign;
- c. Be of the same dimensions as a mandatory instruction marking;
- d. Be displayed across the surface of the taxiway or apron and positioned to be legible from the cockpit of an approaching Air System; and
- e. Use characters 4 m high in the form and proportion shown in Figure 15.

71. Where there is insufficient contrast between the marking background and the pavement surface, the marking **should** include:

- a. A black border where the inscriptions are in black; and
- b. A yellow border where the inscriptions are in yellow.

**Guidance
Material
3514(9)**

Information Markings

72. Where operationally required to assist in the prevention of a runway incursion, an information sign may be supplemented by an information (location / direction) marking which may be:

- a. Displayed prior to and following complex taxiway intersections and where operational experience has indicated the addition of a taxiway location marking could assist flight crew ground navigation; and
- b. Displayed on the pavement surface at regular intervals along taxiways of great length.

Civil Equivalence.

73. This regulation is in line with ICAO Annex 14 Vol I para 5.2.17.

Intentionally Blank for Print Pagination

RA 3515 - Permanent Fixed Wing Aerodrome - Lighting

Rationale

Most Aerodromes have a requirement to operate in all weather conditions and at all times of the day. At night, or in poor visibility conditions by day, lighting can be more effective than marking to enhance the Safety of ► Aircraft ◀ operations. Aeronautical Ground Lights (AGL) provide clear and consistent information and guidance to the aviation community under all operating conditions.

Contents

- 3515(1): Lighting - Scaling
- 3515(2): Lighting - Dangerous or Confusing Lights
- 3515(3): Approach Lighting - Obstacle Profile
- 3515(4): Aeronautical Beacons - Identification Beacons
- 3515(5): Approach Lighting - Simple Approach Lighting System
- 3515(6): Approach Lighting - High Intensity Centreline and Crossbar Approach System
- 3515(7): Approach Lighting - Supplementary Approach Lighting
- 3515(8): Approach Lighting - Precision Approach Path Indicator
- 3515(9): Runway Lights - Runway Edge Lights
- 3515(10): Runway Lights - Runway Threshold Lights
- 3515(11): Runway Lights - Runway Threshold Wing Bar Lights
- 3515(12): Runway Lights - Runway End Lights
- 3515(13): Runway Lights - Runway Centreline Lights
- 3515(14): Runway Lights - Runway Touchdown Zone Lights
- 3515(15): Runway Lights - Stopway Lights
- 3515(16): Taxiway Lights - Taxiway Centreline Lights
- 3515(17): Taxiway Lights - Taxiway Edge Lights
- 3515(18): Taxiway Lights - Stop Bar Lights
- 3515(19): Taxiway Lights - Runway Guard Lights
- 3515(20): Taxiway Lights - Road-Holding Position Lights
- 3515(21): Apron Lights - Edge Lighting
- 3515(22): Apron Lights - Floodlighting
- 3515(23): Miscellaneous Lights - Undercarriage Inspection Systems
- 3515(24): Miscellaneous Lights - Arrestor Cable Systems and Illuminated Runway Distance to go Markers
- 3515(25): Miscellaneous Lights - Visual Docking Guidance System
- 3515(26): Miscellaneous Lights - Advanced Visual Docking Guidance System
- 3515(27): Miscellaneous Lights - Emergency Portable Lighting
- 3515(28): Aeronautical Ground Lights Characteristics - Construction
- 3515(29): Aeronautical Ground Lights Characteristics - Intensity and Distribution
- 3515(30): Aeronautical Ground Lights Characteristics - Colour and Discrimination

**Regulation
3515(1)**

Lighting - Scaling

3515(1) Heads of Establishments (HoEs) and Aviation Duty Holder-Facing Organizations (ADH-Facing Organizations) **shall** ensure that the Aerodrome provides a minimum level of AGL to support ►Aircraft◀ movements during low visibility and night operations.

**Acceptable
Means of
Compliance
3515(1)**

Lighting - Scaling

1. An Aerodrome Operator **should** establish and publish Operating Minima for an Aerodrome's operation. Minimum prescribed scales of AGL **should** be in accordance with (iaw) Table 1.

Table 1. Minimum Prescribed Scale of AGL.

| | Operating Category | | | |
|---|----------------------|----------------------------------|-------------------|--------------------|
| | CAT II Precision App | CAT I Precision App ^a | Non-Precision App | Non-Instrument App |
| Illuminated Wind Direction Indicator | O►b◄ | O►b◄ | O►b◄ | O►b◄ |
| Aerodrome Beacon | R | R | R | R |
| Simple Approach | - | - | R | O |
| HI C/L 5 Bar Approach | R | R | - | - |
| Supplementary Approach | R | - | - | - |
| Precision Approach Path Indicator (PAPI) | R | R | R | R |
| Runway Edge | R | R | R | R |
| Threshold | R | R | R | R |
| Threshold Wing Bar | O | O | O | O |
| Runway End | R | R | R | R |
| Runway Centreline | R | O►c◄ | - | - |
| Touchdown Zone | R | - | - | - |
| Stopway | R | R | R | R |
| Taxiway Centreline | R | O►d◄ | - | - |
| Taxiway Edge | - | O►d◄ | R | R |
| Stop Bars | R | - | - | - |
| Runway Guard Lights | R | - | - | - |
| Illuminated Runway Signs | R | R | R | O |
| Obstacle ►Lighting◄ | R | R | R | R |
| Alternate Power Supply | R | R | R | O |
| KEY R = Required, O = Operationally Desirable, C/L = Centreline, HI = High Intensity, LI = Low Intensity App = Approach, PAR = Precision Approach Radar | | | | |

**Acceptable
Means of
Compliance
3515(1)**

- a. If a Runway is declared as a Precision Approach Runway, through having a PAR, then it **should** have corresponding levels of lighting relative to the declared operating minima at the Aerodrome.
- b. ► **At least one illuminated wind direction indicator should be provided where there is a requirement for night flying.**
- c. **Runway centreline lighting should be provided on Runways intended to be used for take-off with an operating minimum below a Runway Visual Range (RVR) of 400 m. ◀**
- d. Taxiway edge lighting may be replaced by taxiway centreline lighting.

**Guidance
Material
3515(1)**

Lighting - Scaling

2. Where the prescribed AGL requirements cannot be provided there may be a consequential penalty on operational minima.
3. It is noted that all Runways at an Aerodrome may not be required to have the same scale of visual aids. ► **This RA** ◀ requires the scale of visual aids be determined according to the Operating Minima, Nature and Types of ► **Aircraft** ◀ operations.
4. Light emitting diode (LED) fittings may be used on Runway, approach, Apron, taxiways, signage, road-holding position lights, Runway guard lights and stop bars, provided that an assessment of the impact on Night Vision Device (NVD) operations is carried out.
5. The energy savings of LED are due in large part to the fact that they do not produce the infra-red heat signature of incandescent lamps. Aerodrome Operators who have come to expect the melting of ice and snow by this heat signature may wish to evaluate whether a modified Maintenance schedule is required during such conditions or evaluate the possible operational value of installing LED fixtures with heating elements.
6. Enhanced vision systems (EVS) technology relies on the infra-red heat signature provided by incandescent lighting. International Civil Aviation Organization (ICAO) Annex 15¹ protocols provide an appropriate means of notifying Aerodrome users of EVS when lighting systems are converted to LED.
7. Centreline lighting may be provided on taxiways with a width greater than 18 m.

**Regulation
3515(2)**

Lighting - Dangerous or Confusing Lights

- 3515(2) HoEs and ADH-Facing Organizations **shall** ensure that, wherever possible, any non-AGL on or near an Aerodrome which might endanger the Safety of ► **Aircraft** ◀ is extinguished, screened or otherwise modified to eliminate the Hazard.

**Acceptable
Means of
Compliance
3515(2)**

Lighting - Dangerous or Confusing Lights

8. Attention **should** be directed to the following areas²:
 - a. Instrument Runway - Code Number 4-6:
 - (1) Within the areas before the threshold and beyond the end of the Runway extending at least 4500 m in length from the threshold and Runway end and 750 m either side of the extended Runway centreline in width.
 - b. Instrument Runway - Code Number 2 or 3:
 - (1) Within the areas before the threshold and beyond the end of the Runway extending at least 3000 m in length from the threshold and

¹ ICAO Annex 15 – Aeronautical Information Services.

² Refer to RA 3510 – Permanent Fixed Wing Aerodrome - Reference Information for information on Aerodrome Reference Codes.

**Acceptable
Means of
Compliance
3515(2)**

- Runway end and 750 m either side of the extended Runway centreline in width.
- c. Instrument Runway - Code Number 1 and Non-Instrument Runway:
(1) Within the approach area.
9. Floodlighting within the areas described in paragraph 8 **should not** allow upward emission of light.
10. Floodlights **should not** be installed where they may obscure the view of the manoeuvring area from the ► Visual Control Room.◀
11. Outside the areas described in paragraph 8, floodlighting **should** be limited as follows:
- 0° elevation above horizontal: maximum intensity 1000 cd.
 - Up to 10° elevation above horizontal: maximum intensity 500 cd.
 - Up to 15° elevation above horizontal: maximum intensity 250 cd.
 - Over 30° elevation above horizontal: maximum intensity 100 cd.
12. Street lighting intensities within the areas described in paragraph 8 **should not** allow upward emission of light.
13. Where the pattern of street lighting may be confused with the AGL, in which case no upward light is permitted, outside the areas described in paragraph 8, street lighting **should** be limited as follows,
- 0° elevation above horizontal: maximum intensity 750 cd.
 - Up to 2° elevation above horizontal: maximum intensity 300 cd.
 - Up to 4° elevation above horizontal: maximum intensity 95 cd.
 - Up to 6° elevation above horizontal: maximum intensity 75 cd.
 - Up to 10° elevation above horizontal: maximum intensity 60 cd.
 - Up to 30° elevation above horizontal: maximum intensity 30 cd.
 - Up to 40° elevation above horizontal: maximum intensity 20 cd.
 - Up to 50° elevation above horizontal: maximum intensity 10 cd.
 - Over 60° elevation above horizontal: maximum intensity 0 cd.

**Guidance
Material
3515(2)**

Lighting - Dangerous or Confusing Lights

14. Nil.

**Regulation
3515(3)**

Approach Lighting - Obstacle Profile

- 3515(3) HoEs and ADH-Facing Organizations **shall** ensure that objects are restricted from protruding into the Approach Light Plane.

**Acceptable
Means of
Compliance
3515(3)**

Approach Lighting - Obstacle Profile

15. The Approach Light Plane **should** extend:
- 60 m beyond the approach end of the light system; and
 - 60 m horizontally either side of the centreline of the system.
16. The Approach Centreline Light profile **should**:
- Have a vertical profile limit no greater than 1 in 66 rise and no less than 1 in 66 fall for the first 300 m, and 1 in 40 fall thereafter;
 - Have a lateral gradient of the centreline lights in each crossbar no greater than 1 in 80 with the mid-point in the plane of the centreline lights; and the

**Acceptable
Means of
Compliance
3515(3)**

gradients of the centreline in any section (including a stopway or clearway) be as small as practicable. The changes in gradients **should** be as few and small as can be arranged and **should not** exceed 1 in 60³.

c. No obstacle **should** penetrate the Approach Light Plane apart from Instrument Landing System (ILS) azimuth antenna. The antenna **should** be treated as an obstacle and lighted accordingly.

d. Within a stopway or clearway, and within 150 m of the end of a Runway, the lights **should** be mounted as near to the ground as local conditions permit in order to minimize Risk of damage to ► **Aircraft** ◀ in the event of an overrun or undershoot. Beyond the stopway and clearway, it is not so necessary for the lights to be mounted close to the ground, and therefore undulations in the ground contours can be compensated for by mounting the lights on poles of appropriate height.

**Guidance
Material
3515(3)**

Approach Lighting - Obstacle Profile

17. An area referred to as the light plane has been established for obstacle clearance purposes, and all lights of the system are in this plane. This plane is rectangular in shape and symmetrically located about the approach lighting system's centreline.

18. No objects are permitted to exist within the boundaries of the light plane which are higher than the light plane except as designated herein. All roads and highways are considered as obstacles extending 4.8 m above the crown of the road, except Aerodrome service roads where all vehicular traffic is under control of the Aerodrome authorities and coordinated with ► **Air Traffic Control (ATC)**. ◀ Railroads, regardless of the amount of traffic, are considered as obstacles extending 5.4 m above the top of the rails.

19. Objects existing within the boundaries of the light plane, requiring the light plane to be raised to meet the criteria contained herein, need to be removed, lowered or relocated where this can be accomplished more economically than raising the light plane.

20. In some instances, objects may exist which cannot be removed, lowered or relocated economically. These objects may be located so close to the threshold that they cannot be cleared by the 2% slope. Where such conditions exist and no alternative is possible, the 2% slope may be exceeded or a "stair step" resorted to in order to keep the approach lights above the objects. Such "step" or increased gradients may be resorted to only when it is impracticable to follow standard slope criteria, and they need to be held to the absolute minimum. Under this criterion no negative slope is permitted in the outermost portion of the system.

21. Where an ILS localiser is installed within the light plane boundaries, it is recognized that the localiser may extend above the light plane.

Civil Equivalence.

22. This Regulation is in line with ICAO Annex 14 Vol I section 5.3.4 and Attachment A sections 12.1 – 12.4.

**Regulation
3515(4)**

Aeronautical Beacons - Identification Beacons

3515(4) HoEs and ADH-Facing Organizations **shall** ensure that an Aeronautical Identification Beacon is provided at an Aerodrome that is intended for use at night.

³ Experience has shown that as one proceeds outwards from the Runway, rising gradients in any section of up to 1 in 66, and falling gradients of down to 1 in 40, are acceptable.

**Acceptable
Means of
Compliance
3515(4)**

Aeronautical Beacons - Identification Beacons

23. An Aeronautical Identification Beacon **should**:
- Be located on or adjacent to the Aerodrome in an area of low ambient background lighting;
 - Be located such that the beacon is not shielded by objects and does not dazzle a pilot ► **conducting an approach to the landing surface**; ◀
 - Flash in red a 2 letter Morse code symbol as promulgated in the Military Aeronautical Information Publications (AIP);
 - Show in all angles of azimuth and the vertical light distribution will extend upwards from an elevation of not more than 1°;
 - Have an intensity not less than 2000 cd in white; and
 - Have a speed of transmission of between 6 to 8 words per minute.

**Guidance
Material
3515(4)**

Aeronautical Beacons - Identification Beacons

Civil Equivalence.

24. This Regulation is in line with ICAO Annex 14 Vol I para 5.3.3.

**Regulation
3515(5)**

Approach Lighting - Simple Approach Lighting System

- 3515(5) HoEs and ADH-Facing Organizations **shall** ensure that a simple approach lighting system is provided to serve a non-precision approach Runway, except when the Runway is used only in conditions of good visibility or sufficient guidance is provided by other visual aids.

**Acceptable
Means of
Compliance
3515(5)**

Approach Lighting - Simple Approach Lighting System

25. For a non-instrument Runway intended for use at night, a simple approach lighting system **should** be provided.
26. For a non-precision approach Runway intended for use at night, a simple approach lighting system **should** be provided.
27. A Simple Approach Lighting System **should**:
- Consist of a row of lights on the extended centreline of the Runway extending over a distance of not less than 420 m from the threshold with a row of lights forming a crossbar 30 m in length at a distance of 300 m from the threshold (Figure 1).
 - Have crossbar lights that:
 - Are as close as practicable in a horizontal straight line at right angles to, and bisected by, the line of the centreline lights;
 - Are spaced to produce a linear effect, except that, when a crossbar of 30 m is used, gaps may be left on each side of the centreline. These gaps **should** be kept to a minimum to meet local requirements, and each **should** be no greater than 6 m; and
 - Are spaced laterally 2.7 m apart.
 - Have centreline lights that:
 - Are placed at longitudinal intervals of 60 m;
 - Have the innermost light located 60 m from the threshold; and
 - Are a single source or a barrette with a minimum length of 3 m.
 - Be fixed lights showing variable white;

**Acceptable
Means of
Compliance
3515(5)**

- e. Where provided for a non-instrument Runway, show at all angles in azimuth necessary to a pilot on base leg and final approach;
- f. Where provided for a non-precision approach Runway, show at all angles in azimuth necessary to the pilot of an ► Aircraft ◀ which on final approach does not deviate by an abnormal amount from the path defined by the non-visual aid; and
- g. Have a suitable intensity control to allow adjustment to meet the prevailing conditions and to avoid dazzling the pilot during approach and landing.

Figure 1. Simple Approach Lighting System.

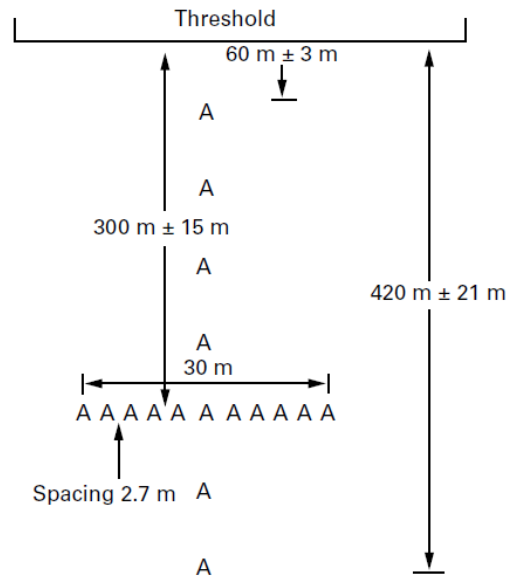

**Guidance
Material
3515(5)**

Approach Lighting - Simple Approach Lighting System

28. When it is desired to improve the guidance, centreline light spacing interval of 30 m may be used.
29. The colour of the lights is to ensure that the system is readily distinguishable from other AGL, and from extraneous lighting if present.
30. If it is not physically possible to provide a centreline extending for 420 m from the threshold, it could be extended to 300 m in order to include the crossbar. If this is not possible, the centreline lights ► will ◀ be extended as far as practicable, and each centreline light will then consist of a barrette at least 3 m in length. Subject to the approach system having a crossbar at 300 m from the threshold, an additional crossbar may be provided at 150 m from the threshold.

Civil Equivalence.

31. This Regulation is in line with ICAO Annex 14 Vol I sections 5.3.4.4 – 5.3.4.7.

**Regulation
3515(6)**

Approach Lighting - High Intensity Centreline and Crossbar Approach System

- 3515(6) HoEs and ADH-Facing Organizations **shall** ensure that a High Intensity Centreline and 5 crossbars approach lighting system is provided to serve a precision approach Runway Category I.

Acceptable Means of Compliance 3515(6)

Approach Lighting - High Intensity Centreline and Crossbar Approach System

- 32. For a CAT I precision approach Runway, a High Intensity Centreline and Crossbar Approach Lighting System **should** be provided.
- 33. A High Intensity Centreline and Crossbar Approach System **should**:
 - a. Consist of a 900 m line of white lights, on the extended centreline of the Runway;
 - b. Have five crossbars at 150 m intervals decreasing in width towards the Runway threshold; lines through the outer lights of the bars **should** converge to meet the Runway centreline 300 m upwind from the threshold (Figure 2); and
 - c. Have a suitable intensity control to allow adjustment to meet the prevailing conditions and to avoid dazzling the pilot during approach and landing (minimum of five stages of luminous intensity).
- 34. The approach lights forming the crossbar **should** be placed as **► much ◀** as practicable in a horizontal straight line at right angles to, and bisected by, the line of the centreline lights.

Figure 2. High Intensity Centreline and Crossbar Approach System

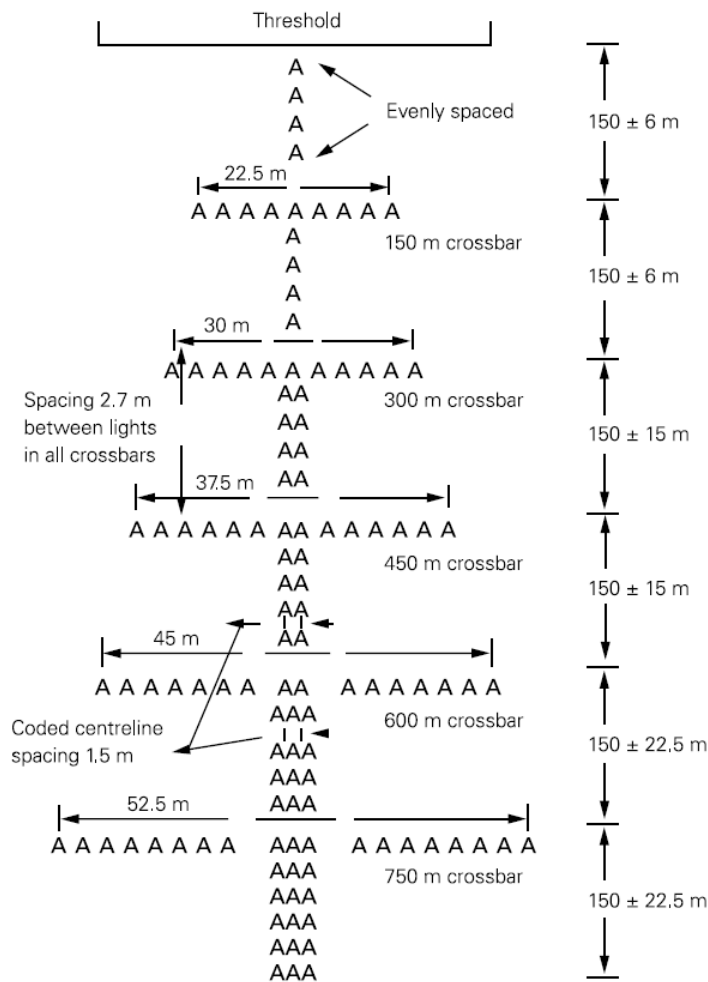

**Guidance
Material
3515(6)**

Approach Lighting - High Intensity Centreline and Crossbar Approach System

35. Terrain or other constraints may limit the length or type of approach lighting that can be installed to less than that specified. In such circumstances, a lesser length may be acceptable, subject to Exemption / Waiver from the MAA, but may incur a penalty on Aerodrome operating minima.

Civil Equivalence.

36. This Regulation is in line with ICAO Annex 14 Vol I sections 5.3.4.10 - 5.4.21.

**Regulation
3515(7)**

Approach Lighting - Supplementary Approach Lighting

3515(7) HoEs and ADH-Facing Organizations **shall** ensure that a supplementary approach lighting system and High intensity centreline with 5 crossbar system is provided for precision approach CAT II and CAT III operations.

**Acceptable
Means of
Compliance
3515(7)**

Approach Lighting - Supplementary Approach Lighting

37. For CAT II and III precision approach Runways, a high intensity centreline and crossbar approach system with supplementary approach lighting **should** be provided.

38. Supplementary Approach Lighting **should**:

- a. Consist of two additional white lights on each side of the centreline light forming rows along the inner 300 m of the approach centreline, the lights in each row being spaced 1.2 m apart as shown in Figure 3;
- b. Have red side rows of four lights spaced 1.5 m apart on each side of each centreline row over the inner 270 m of the approach lighting system;
- c. Have the red side row lights set at the same lateral spacing (gauge) as the touchdown zone lights;
- d. At the crossbar 150 m from the threshold, have a lateral spacing of 2.25 m to fill the gap between the centreline and side row lights; and
- e. Have a suitable intensity control to allow adjustment to meet the prevailing conditions and to avoid dazzling the pilot during approach and landing (minimum of 3 stages of luminous intensity).

Acceptable Means of Compliance 3515(7)

Figure 3. Supplementary Approach Lighting

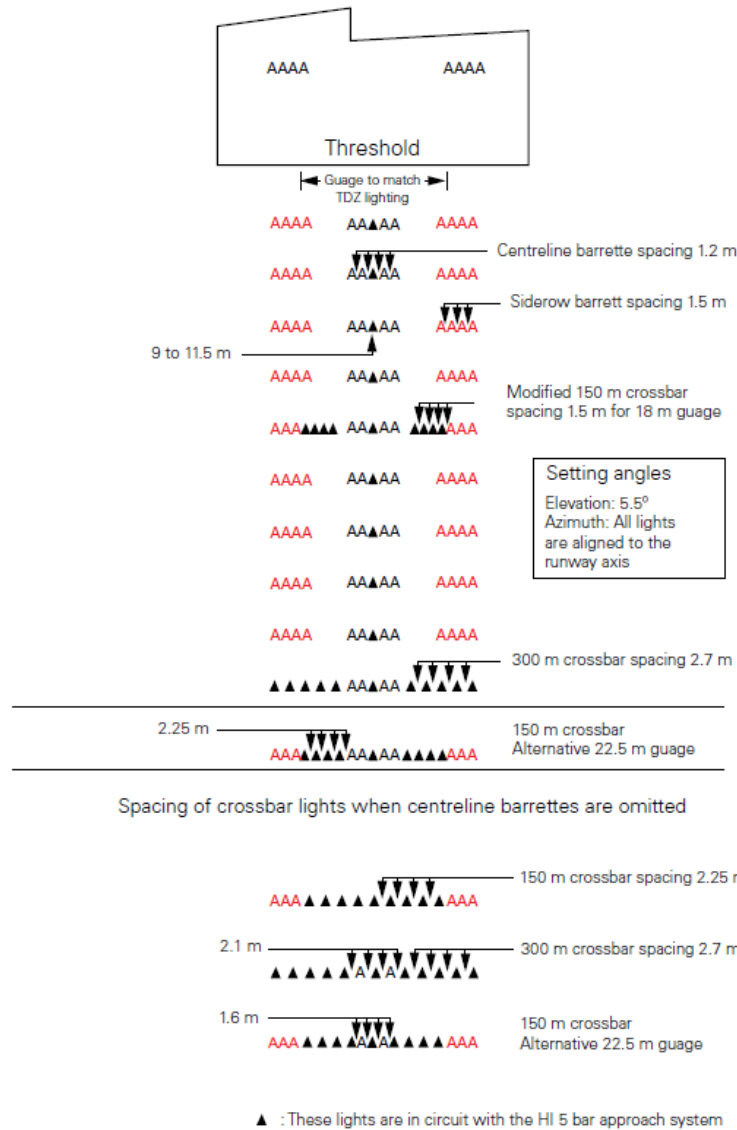

Guidance Material 3515(7)

Approach Lighting - Supplementary Approach Lighting Civil Equivalence.

39. This Regulation is in line with ICAO Annex 14 Vol I para 5.3.4.22 – 5.3.4.39 as applicable.

Regulation 3515(8)

Approach Lighting - Precision Approach Path Indicator

3515(8) HoEs and ADH-Facing Organizations **shall** ensure that a PAPI is installed to provide an accurate depiction of an appropriate approach angle to maintain a safe height over obstacles and the threshold.

Acceptable Means of Compliance 3515(8)

Approach Lighting - Precision Approach Path Indicator

40. The PAPI installation **should**:
- a. Consist of 4 sharp transition multi-lamp units located as a wing bar equally spaced, on each side of the Runway ►so that the wing bars appear opposite each other:◄
 - (1) The inner light unit **should** be 15 m +/-1 m from the Runway edge. No unit **should** be closer than 14 m to any taxiway, Apron, or another Runway;

**Acceptable
Means of
Compliance
3515(8)**

- (2) The spacing between the light units **should** be 9m +/- 1 m;
- b. Be constructed and arranged in such a manner that a pilot making an approach **should**:
- (1) When on, or close to, the approach slope, see the two units nearest the Runway as red and the two units farthest from the Runway as white;
- (2) When above the approach slope, see the one unit nearest the Runway as red and the three units farthest from the Runway as white; and when further above the approach slope, see all the units as white; and
- (3) When below the approach slope, see the three units nearest the Runway as red and the unit farthest from the Runway as white; and when further below the approach slope, see all the units as red;
- c. Have the units forming the wing bar mounted to appear to the pilot of an approaching ►Aircraft◄ to be substantially in a horizontal line;
- d. Have the corresponding light units of the wing bars installed either side of the Runway, set at the same angle so that the signals of each wing bar change symmetrically at the same time;
- e. Have an approach slope as defined in Figure 4 appropriate for use by the ►Aircraft◄ using the approach;
- f. Where the Runway is equipped with a precision approach, have the siting and the angle of elevation of the light units such that the visual approach slope conforms as closely as possible with the glide path of the precision approach;
- g. Have the angle of elevation settings of the light units in a PAPI wing bar such that, during an approach, the pilot of an ►Aircraft◄ observing a signal of one white and three reds will clear all objects in the approach area by a safe margin;
- h. Be mounted as low as possible with the following constraints:
- (1) PAPI units **should** be the minimum practical height above ground and not normally above 0.9 m;
- (2) The units of a wing bar **should** all lie in the same horizontal plane, but where cross falls make this impracticable within the 0.9 m constraint, the height difference between adjacent units **should not** exceed 5 cm. Where even this tolerance cannot be achieved, a maximum gradient of 1.25% across the bar may be accepted if it is uniform;
- i. Have concrete bases either depressed below ground level and covered with a suitable infill, or flush fitted;
- j. Be frangible;
- k. Be suitable for day and night operations; and
- l. Have a suitable intensity control to allow adjustment to meet the prevailing conditions and to avoid dazzling the pilot during approach and landing.

Acceptable Means of Compliance 3515(8)

Figure 4. Approach Slope Definition

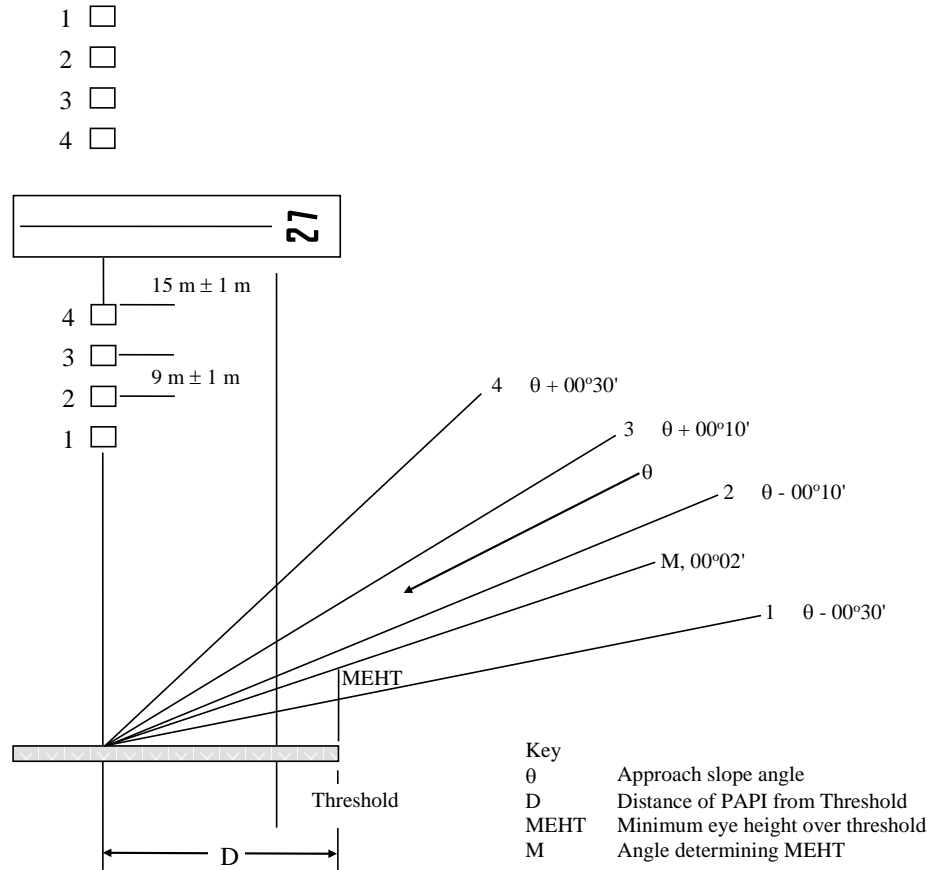

Example settings for a 3° approach:

| | |
|-------------|------------|
| Unit number | 1 = 2° 30' |
| | 2 = 2° 50' |
| | 3 = 3° 10' |
| | 4 = 3° 30' |

If the PAPI is associated with an ILS:

| | |
|-------------|------------|
| Unit number | 1 = 2° 25' |
| | 2 = 2° 45' |
| | 3 = 3° 15' |
| | 4 = 3° 35' |

41. The distance of the PAPI from the Runway threshold **should** be based upon the following:

a. The need to provide adequate wheel clearance over the threshold of a non-instrument or non-precision instrument approach Runway for the most demanding of the ► Aircraft ◀ regularly using the Runway, having due regard to the length of Runway available for stopping the ► Aircraft; ◀

(1) Wheel clearance over the threshold **should** take account of the eye-to-wheel height of the most demanding ► Aircraft ◀ when it is at the lowest possible on-slope signal from the PAPI;

(2) The angle which establishes the Minimum Eye Height over Threshold (MEHT) **should** be two minutes of arc less than the setting angle of the unit defining the lower on-slope boundary as per Figure 4. Where a Runway is not equipped with ILS, MEHT **should** provide the wheel clearances specified in Table 2. The MEHT **should** be the combination of the eye-to-wheel height and the desired wheel clearance;

b. The operational requirement that PAPI be compatible with the instrument glide path down to the minimum possible range and height for the types of ► Aircraft ◀ for which the Runway is intended.

(1) PAPI **should** be sited so that its on-slope signal conforms as closely as possible to that of the instrument glide path. Variables that **should** be

Acceptable Means of Compliance 3515(8)

considered are fluctuations of the instrument glide path and the different eye-to-aerial height of various types of **► Aircraft; ◀**

c. Any difference in elevation between the PAPI units and the Runway threshold. Any height difference between the light unit and the threshold more than 0.3 m **should** be corrected.

42. An Obstacle Protection Surface **should** be established as per Figure 5.

Figure 5 – Obstacle protection Surface for Visual Approach Slope Indicator Systems

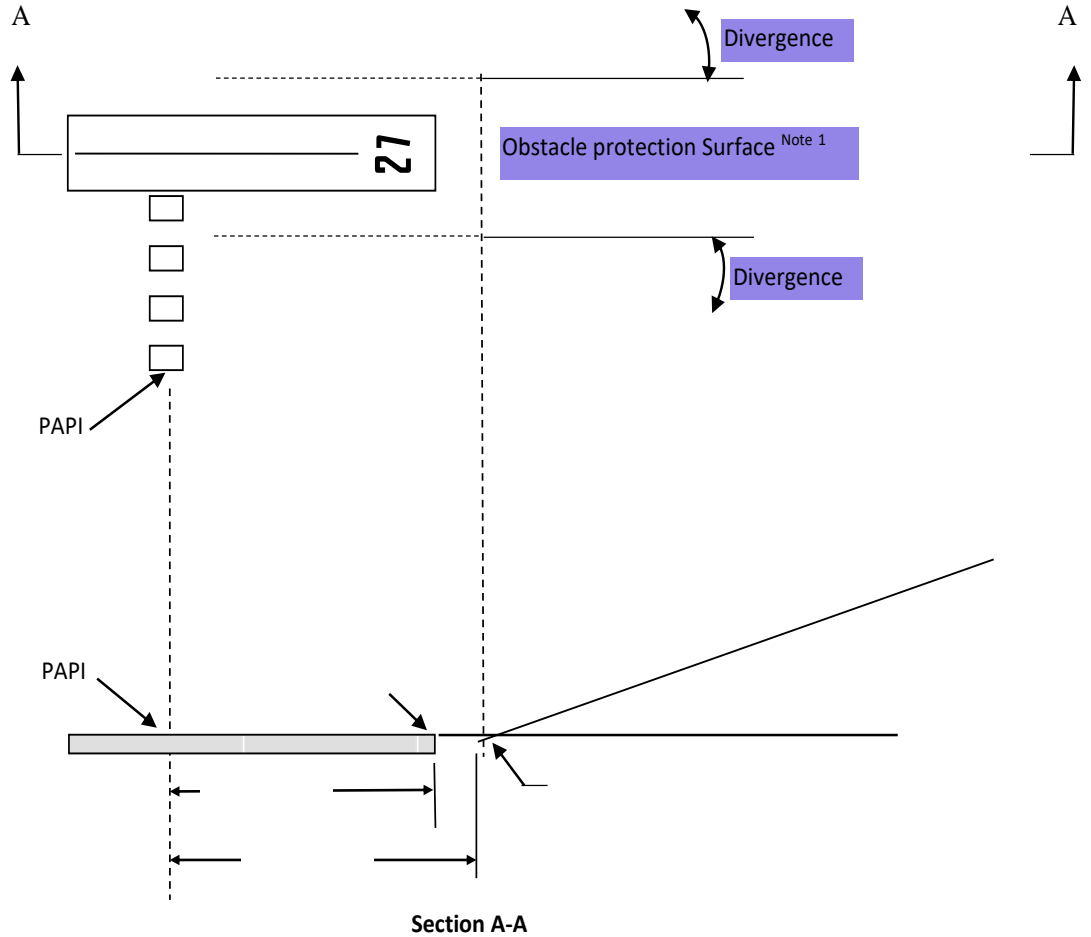

Notes:

- 1 Refer to ICAO Annex 14 Vol 1 Table 5.3 & Figure 5.19
- 2 Refer to ICAO Annex 14 Vol 1 Figure 5.19
- 3 Refer to ICAO Annex 14 Vol 1 Table 5.3

Table 2. Wheel clearance over threshold for PAPI and (A)PAPI

| Eye-to-wheel height of ► Aircraft ◀ in the approach configuration ►a◀ | Desired wheel clearance ►b, c◀ (metres) | Minimum wheel clearance ►d◀ (metres) |
|---|--|---|
| (1) | (2) | (3) |
| up to but not including 3 m | 6 | 3 ►e◀ |
| 3 m to but not including 5 m | 9 | 4 |
| 5 m to but not including 8 m | 9 | 5 |
| 8 m to but not including 14 m | 9 | 6 |

**Acceptable
Means of
Compliance
3515(8)**

►^a In selecting the eye-to-wheel height group, only Aircraft meant to use the system on a regular basis **should** be considered. The most demanding amongst such Aircraft **should** determine the eye-to-wheel height group.
^b Where practicable the desired wheel clearances shown in column (2) **should** be provided.
^c The wheel clearances in column (2) may be reduced to no less than those in column (3) where an aeronautical study indicates that such reduced wheel clearances are acceptable.
^d When a reduced wheel clearance is provided at a displaced threshold it **should** be ensured that the corresponding desired wheel clearance specified in column (2) will be available when an Aircraft at the top end of the eye-to-wheel height group chosen overflies the extremity of the Runway.
^e This wheel clearance may be reduced to 1.5 m on Runways used mainly by lightweight non-turbojet Aircraft. ◀

43. The PAPI light units **should**:
- a. Have a light intensity distribution iaw RA 3515(29);
 - b. Have a colour transition from red to white in the vertical plane appear to an observer, at not less than 300 m, to occur within a vertical angle of not more than ►3';◀
 - c. At full intensity, have a red light Y coordinate not exceeding 0.320;
 - d. Be capable of adjustment in elevation so that the lower limit of the white part of the beam may be fixed at any desired angle of elevation between 1° 30' and at least 4° 30' above the horizontal;
 - e. Be so designed that deposits of condensation, snow, ice, dirt, etc., on optically transmitting or reflecting surfaces interfere to the least possible extent with the light signals and **should not** affect the contrast between the red and white signals and the elevation of the transition sector; and
 - f. Have the azimuth spread of the light beam adjusted where an object located outside the obstacle protection surface of the PAPI system, but within the lateral limits of its light beam, is found to extend above the plane of the obstacle protection surface and an aeronautical study indicates that the object could adversely affect the Safety of operations. The extent of the restriction **should** be such that the object remains outside the confines of the light beam.

**Guidance
Material
3515(8)**

Approach Lighting - Precision Approach Path Indicator

44. A spacing of 6 m (±1 m) between PAPI units may be used on a Runway with code numbers 1 or 2. In such an event, the inner PAPI unit needs to be located not less than 10 m (±1 m) from the Runway edge.
45. An ILS glide path has a tolerance of ±0.075 of the nominal glide path angle for a Category I or II system and of ±0.04 for a Category III. For a nominal 3° glideslope the tolerances are ±13.5 and ±7.2 min of arc respectively. The standard PAPI settings define a glideslope within ±10 min of arc and can therefore show a variation from a nominal ILS glideslope that is operating within its tolerances.
46. Flight crew's pilot's eye-to-aerial height varies considerably with ►Aircraft◀ type and will affect the minimum range to which PAPI and ILS harmonisation is achieved. To allow for the full range of ►Aircraft,◀ harmonisation may be enhanced by widening the on-slope sector from 20 min to 30 min of arc. The ILS glide path angle may vary, so it is desirable to check the calibrated ILS Glide Path angle against the PAPI settings and to change the latter if necessary.
47. When the required approach angle and associated unit setting angles have been determined, the parameters are applied as follows:
- a. To provide the appropriate wheel clearance over the threshold of a non-instrument or non-precision instrument approach Runway, the distance of PAPI from the threshold is established by adding the approach configuration eye-to-wheel height of ►Aircraft◀ for which the Runway is intended to the required

**Guidance
Material
3515(8)**

threshold wheel clearance and dividing the result by the tangent of angle M in Figure 4.

b. Where ILS is installed the PAPI will need to be sited upwind of the effective ILS glide path origin by a distance that is dependent upon the range of eye-to-aerial heights of the ►Aircraft◀ using the Runway.

c. For further information regarding the Obstacle Protection Surface (OPS) see ICAO Annex 14 Vol 1 Table 5-3.

d. The OPS, its origin and divergence, are determined iaw Figure 5. The OPS is to be examined to confirm the absence of infringements. If the surface is penetrated but the offending object cannot be removed, the vertical extent of the infringement is divided by the tangent of the OPS angle, and the PAPI relocated that much further from the threshold. Alternatively, where a prescribed approach angle is not critical, it may be increased by the angular extent of the infringement. In some circumstances a combined displacement and angular increase may be the best solution.

e. A height difference between threshold and unit lens centres exceeding 0.3 m will require a siting adjustment as follows:

(1) In Figure 6 the uncorrected visual aiming point is shown as the distance D_1 from the threshold. The nominal siting of PAPI would be on a line at right angles to the Runway centreline at this distance, the units being P_1 , P_2 , P_3 and P_4 .

(2) The height difference between the threshold (T_h), and the lens centre of the highest of the units (P_n) at the nominal sites P_1 to P_4 is determined. The following formula will determine the revised distance from threshold D_2 : $D_1 + (T_h - P_n) \cot \emptyset = D_2$, where \emptyset is the setting angle of the unit at site P_2 , less 2 minutes of arc ($\cot \emptyset$ can be taken as 20 for a 3° approach).

(3) The highest unit level at distance D_2 , (P_c) is compared with P_n . If the difference is 0.3 m or more, the final siting, D_3 , is determined as follows: $D_2 + (P_n - P_c) \cot \emptyset = D_3$.

(4) The MEHT resulting from the level of unit P_2 at D_3 is checked to ensure that it achieves the original target.

48. As approach angles steepen, wider differential settings are needed between units to facilitate approach slope capture and flyability. Those differential settings that have been found to be satisfactory are:

- a. 2-4° approach angle: 20 min differential setting angle (except for ILS);
- b. 4-7° approach angle: 30 min differential setting angle;
- c. Over 7° approach angle: 1° differential setting angle.

Civil Equivalence.

49. This Regulation is in line with ICAO Annex 14 Vol I para 5.3.5.24 – 5.3.5.41.

**Guidance
Material
3515(8)**

Figure 6. PAPI Siting – Principle of Compensation for Different Ground Heights

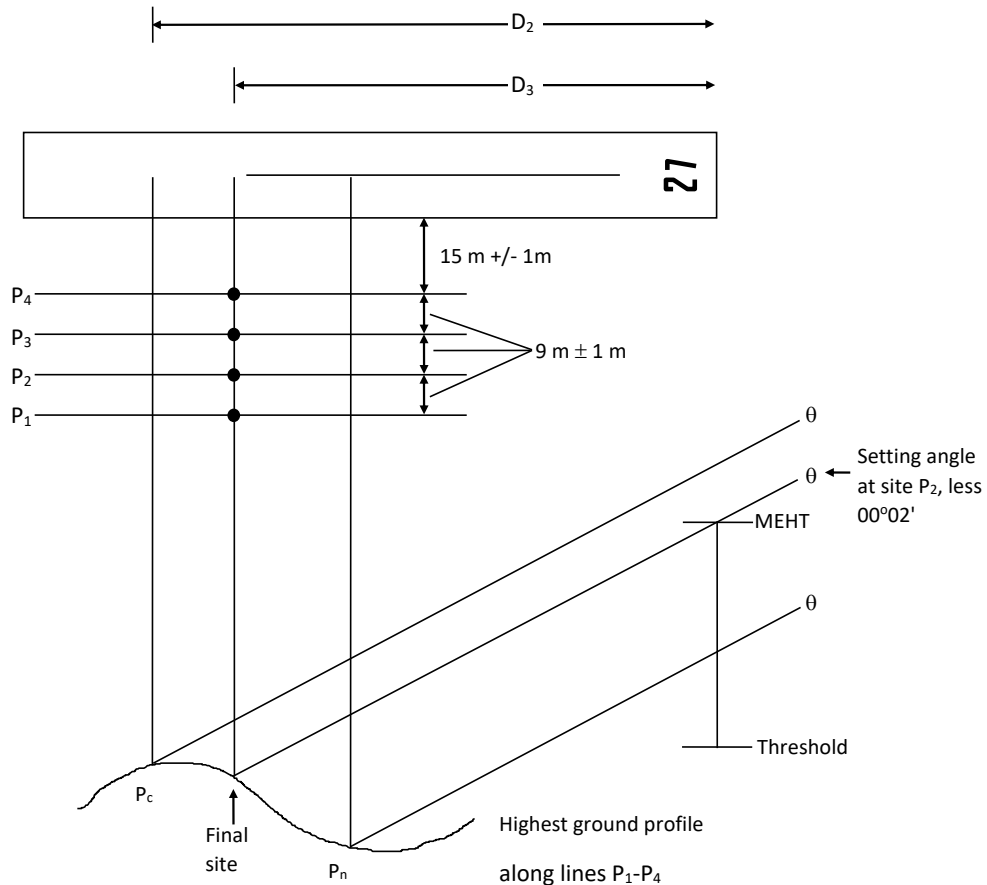

**Regulation
3515(9)**

Runway Lights - Runway Edge Lights

3515(9) HoEs and ADH-Facing Organizations **shall** ensure that Runway edge lights are provided for a Runway intended for use at night or for a precision approach Runway intended for use by day or night.

**Acceptable
Means of
Compliance
3515(9)**

Runway Lights - Runway Edge Lights

50. Runway edge lights **should**:
- Be placed along the full length of the Runway and **should** be in two parallel rows equidistant from the centreline;
 - Be placed along the edges of the area declared for use as the Runway or outside the edges of the area at a distance of not more than 3 m;
 - Be uniformly spaced in rows at intervals of not more than 60 m for an instrument Runway, and at intervals of not more than 100 m for a non-instrument Runway;
 - For lights on opposite sides of the Runway axis, be on lines at right angles to that axis;
 - Where the width of the area which could be declared as Runway exceeds 50 m have a distance between the rows of lights determined considering:
 - The nature of the operations;
 - The light distribution characteristics of the Runway edge lights; and
 - Other visual aids serving the Runway;

**Acceptable
Means of
Compliance
3515(9)**

- f. On a Runway without centreline lighting, a section of the lights 600 m or one-third of the Runway length, whichever is the less, at the remote end of the Runway from the end at which the take-off run is started, **should** show yellow;
- g. Be fixed white lights showing variable white except:
- (1) In the case of a displaced threshold, the lights between the beginning of the Runway and the displaced threshold **should** show red in the approach direction; and
 - (2) A section of the lights 600 m or one-third of the Runway length, whichever is the less, at the remote end of the Runway from the end at which the take-off run is started, may show yellow.
- h. Have intensity and beam spread iaw characteristics specified in RA 3515(29).

51. When the Runway edge lights are intended to provide circling guidance, they **should** show at all angles in azimuth and show at angles up to 15° above the horizontal with an intensity adequate for the conditions of visibility and ambient light in which use of the Runway for take-off or landing is intended. The intensity **should** be at least 50 cd except at an Aerodrome without extraneous lighting, the intensity of the lights may be reduced to not less than 25 cd to avoid dazzling the pilot. Where required, both a high intensity edge light unit and a unit for circling guidance may be collocated or have a combined unit installation.

52. Runway edge lights on a precision approach Runway **should** be iaw the specifications in RA 3515 (29).

**Guidance
Material
3515(9)**

Runway Lights - Runway Edge Lights

53. At intersections of Runways, lights may be spaced irregularly or omitted, provided that adequate guidance remains available to the pilot.

54. To prevent damage occurring to the light units, inset edge lights may be used within the swept area of an ► Aircraft ◀ arresting system.

55. Where required, both a high intensity edge light unit and a unit for circling guidance may be collocated or have a combined unit installation.

56. Where the width of the area which could be declared as Runway exceeds 60 m, the distance between the rows of lights may be determined considering the nature of the operations, the light distribution characteristics of the Runway edge lights, and other visual aids serving the Runway

57. The section of the lights 600 m or one-third of the Runway length, whichever is the less, at the remote end of the Runway from the end at which the take-off run is started, may also show white colour where Runway centreline lights or Illuminated Runway Distance Markers are installed.

58. On a Runway without high intensity lighting system, low intensity omnidirectional Runway edge white lights may have average intensity in a range of 100 cd – 200 cd at angles up to 7° above the horizontal. In addition, the requirements from para 50 are also to be maintained where a circling guidance from these Runway edge light units is required.

Civil Equivalence.

59. This Regulation is in line with ICAO Annex 14 Vol I Section 5.3.9.

**Regulation
3515(10)**

Runway Lights - Runway Threshold Lights

3515(10) HoEs and ADH-Facing Organizations **shall** ensure that Runway threshold lights are provided for a Runway equipped with Runway edge lights, except on a non-instrument or non-precision approach Runway where the threshold is displaced, and wing bar lights are provided.

**Acceptable
Means of
Compliance
3515(10)**

Runway Lights - Runway Threshold Lights

60. Runway threshold lights **should**:
- a. When a threshold is at the extremity of a Runway, be placed in a row at right angles to the Runway axis as near to the extremity of the Runway as possible and, not more than 3 m outside the extremity;
 - b. When a threshold is displaced from the extremity of a Runway, be placed in a row at right angles to the Runway axis at the displaced threshold;
 - c. Be symmetrically disposed about the Runway centreline in two groups, with the lights uniformly spaced in each group and **should** consist of:
 - (1) On a non-instrument or non-precision approach Runway, at least six lights;
 - (2) On a precision approach Runway Category I, at least the number of lights that would be required if the lights were uniformly spaced at intervals of 3 m between the rows of Runway edge lights; and
 - (3) On a precision approach Runway Category II or III, lights uniformly spaced between the rows of Runway edge lights at intervals of not more than 3 m.
 - d. Be fixed unidirectional lights showing green in the direction of approach to the Runway;
 - e. Have intensity and beam spread adequate for the conditions of visibility and ambient light in which use of the Runway is intended; and
 - f. Have luminous intensity compatible with that of the Runway edge lights.
 - g. Have intensity and beam spread law characteristics specified in RA 3515(29).

**Guidance
Material
3515(10)**

Runway Lights - Runway Threshold Lights

61. Where an ► Aircraft ◀ arresting system is installed and the threshold lights are located within the hook engagement area (150 m before the barrier) it will be necessary to provide inset light units (fully flush) to avoid hook engagement problems. Where the threshold lights (including Threshold Wing Bars) are installed within the Runway swept area it will be necessary to provide inset light units (semi-flush).

Civil Equivalence.

62. This Regulation is in line with ICAO Annex 14 Vol I Section 5.3.10.

**Regulation
3515(11)**

Runway Lights - Runway Threshold Wing Bar Lights

- 3515(11) HoEs and ADH-Facing Organizations **shall** ensure that Runway threshold wing bar lights are provided on a non-instrument or non-precision approach Runway where the threshold is displaced and Runway threshold lights are required, but are not provided. Runway Threshold Wing bar lights **shall** be provided on a precision approach Runway when additional conspicuity is considered desirable.

**Acceptable
Means of
Compliance
3515(11)**

Runway Lights - Runway Threshold Wing Bar Lights

63. Runway threshold wing bar lights **should**:
- a. Be symmetrically placed about the Runway centreline at the threshold in two groups;
 - b. For each wing bar, be formed by at least five lights extending at least 10 m outward from, and at right angles to, the line of the Runway edge lights, with the innermost light of each wing bar in the line of the Runway edge lights;

**Acceptable
Means of
Compliance
3515(11)**

- c. Be fixed unidirectional lights showing green in the direction of approach to the Runway;
- d. Have intensity and beam spread iaw characteristics specified in RA 3515(29).

**Guidance
Material
3515(11)**

**Runway Lights - Runway Threshold Wing Bar Lights
Civil Equivalence.**

64. This Regulation is in line with ICAO Annex 14 Vol I Section 5.3.10.

**Regulation
3515(12)**

Runway Lights - Runway End Lights

- 3515(12) HoEs and ADH-Facing Organizations **shall** ensure that Runway end lights are provided for a Runway equipped with Runway edge lights.

**Acceptable
Means of
Compliance
3515(12)**

Runway Lights - Runway End Lights

65. Runway End Lights **should**:
- a. Be placed on a line at right angles to the Runway axis as near to the end of the Runway as possible and, in any case, not more than 3 m outside the end;
 - b. Be symmetrically disposed about the Runway centreline in two groups with the lights uniformly spaced in each group and with a gap between the groups of not more than half the distance between the rows of Runway edge lights, and **should** consist of:
 - (1) At least six lights;
 - (2) For a precision approach Runway Category III, have a spacing between Runway end lights, except between the two innermost lights if a gap is used, no greater than 6 m; and
 - (3) Where an arrestor barrier is installed, an additional green light on the Runway centreline with similar characteristics to that of the Runway end lights.
 - c. Be fixed unidirectional lights showing red in the direction of approach to the Runway;
 - d. Have intensity and beam spread iaw characteristics specified in RA 3515(29); and
 - e. Be iaw characteristics specified in RA 3515(29-30).

**Guidance
Material
3515(12)**

**Runway Lights - Runway End Lights
Civil Equivalence.**

66. This Regulation is in line with ICAO Annex 14 Vol I Section 5.3.11.

**Regulation
3515(13)**

Runway Lights - Runway Centreline Lights

- 3515(13) HoEs and ADH-Facing Organizations **shall** ensure that Runway centreline lights are provided on a precision approach Runway Category II or III and on Runways intended to be used for take-off with an operating minimum below a Runway Visual Range (RVR) of ►400◄ m.

**Acceptable
Means of
Compliance
3515(13)**

Runway Lights - Runway Centreline Lights

67. Runway centreline lights **should**:
- Be located along the centreline of the Runway, except that the lights may be uniformly offset to the same side of the Runway centreline by not more than 60 cm where it is not practicable to locate them along the centreline;
 - Be fixed lights showing variable white from the threshold of the Runway to 900 m from the upwind Runway end light position, then the following 600 m **should** be alternate variable white and red lights, and at least the final 300 m to the Runway end light position **should** be all red lights except that for Runways less than 1800 m in length, the alternate red and variable white lights **should** extend from the midpoint of the Runway usable for landing to 300 m from the Runway end light position;
 - Have the electrical circuits for the red and white lights so arranged such that the colour coding is preserved in the event of a circuit failure;
 - Have a spacing between centreline lights of 30 m except that for Category III operations and for take-off in RVR below **▶400◀** m, the spacing **should** be 15 m;
 - Where an **▶Aircraft◀** arresting system is installed be selected to prevent hook engagement problems; and
 - Be in characteristics specified in RA 3515(29-30).

**Guidance
Material
3515(13)**

Runway Lights - Runway Centreline Lights

68. Centreline guidance for take-off from the beginning of a Runway to a displaced threshold may be provided by:
- An approach lighting system if its characteristics and intensity settings afford the guidance required during take-off, and it does not dazzle the pilot of an **▶Aircraft◀** taking off; or
 - Runway centreline lights; or
 - Barrettes of at least 3 m length, and spaced at uniform intervals of 30 m, designed so that their photometric characteristics and intensity setting afford the guidance required during take-off without dazzling the pilot of an **▶Aircraft◀** taking off.
69. Where necessary, provision needs to be made to extinguish those centreline lights, as prescribed in sub-para b above or reset the intensity of the approach lighting system or barrettes when the Runway is being used for landing. When the Runway is being used for landing centreline lights from the beginning of the Runway to a displaced threshold are not to be lit.
70. Runway centreline lights may be provided on a Runway intended to be used for take-off with an operating minimum of an RVR of **▶400◀** m or higher when used by **▶Aircraft◀** with a very high take-off speed, particularly where the width between the Runway edge lights is greater than 50 m.

Civil Equivalence.

71. This Regulation is in line with ICAO Annex 14 Vol I Section 5.3.12.

**Regulation
3515(14)**

Runway Lights - Runway Touchdown Zone Lights

- 3515(14) HoEs and ADH-Facing Organizations **shall** ensure that touchdown zone lights are provided in the touchdown zone of a precision approach Runway Category II or III.

**Acceptable
Means of
Compliance
3515(14)**

Runway Lights - Runway Touchdown Zone Lights

72. Runway Touchdown Zone lights **should**:
- Consist of barrettes symmetrically disposed either side of the Runway centreline;
 - Extend from the threshold for 900 m or to the midpoint of the Runway, whichever is less;
 - Have barrettes with four white lights spaced not more than 1.5 m apart, the innermost lights being not less than 9 m nor more than 11.5 m either side of the centreline;
 - Have longitudinal spacing between pairs of barrettes of either 30 m or 60 m;
 - Have a lateral gauge of the barrettes equal to that of the Supplementary Approach lighting red side row barrettes; and
 - Be in accordance with characteristics specified in RA 3515(29-30).

**Guidance
Material
3515(14)**

Runway Lights - Runway Touchdown Zone Lights

73. To allow for operations at lower visibility minima, it may be advisable to use a 30 m longitudinal spacing between barrettes.

Civil Equivalence.

74. This Regulation is in line with ICAO Annex 14 Vol I para 5.3.13.

**Regulation
3515(15)**

Runway Lights - Stopway Lights

- 3515(15) HoEs and ADH-Facing Organizations **shall** ensure that stopway lights are provided for a stopway intended for use at night.

**Acceptable
Means of
Compliance
3515(15)**

Runway Lights - Stopway Lights

75. Stopway lights **should**:
- Consist of four unidirectional red lights, in the direction of the Runway on a line at right angles to the stopway axis as near to the end of the stopway as possible and, not more than 3 m outside the end;
 - Be equally spaced across the width of the stopway with the outermost light in line with the Runway edge lights;
 - Where marking the edge of the stopway, be placed in pairs of similar red lights at a uniform spacing not exceeding the spacing of Runway edge light and equidistant from the centreline and coincident with the rows of the Runway edge lights;
 - Be in accordance with characteristics specified in RA 3515(29) – (30).

**Guidance
Material
3515(15)**

Runway Lights - Stopway Lights

Civil Equivalence.

76. This Regulation is in line with ICAO Annex 14 Vol I para 5.3.16.

**Regulation
3515(16)**

Taxiway Lights - Taxiway Centreline Lights

- 3515(16) HoEs and ADH-Facing Organizations **shall** ensure that taxiway centreline lights are provided on an exit taxiway, taxiway, de-icing / anti-icing facility, and Apron serving a precision approach Runway Category II or III in such a manner as to provide continuous guidance between the Runway centreline and ► **Aircraft** ◀ stands.

**Acceptable
Means of
Compliance
3515(16)**

Taxiway Lights - Taxiway Centreline Lights

77. Taxiway centreline lights **should** be provided:
- a. On a Runway forming part of a standard taxi-route and intended for taxiing in RVR conditions less than a value of 350 m. On such a taxiway the longitudinal spacing **should not** exceed 15 m. These lights need not be provided where the traffic density is light and taxiway edge lights and centreline marking provide adequate guidance.
 - b. On a taxiway or Runway forming part of a standard taxi-route; the lights **should**:
 - (1) Be fixed lights showing green with beam dimensions such that the light is visible only from ► Aircraft ◀ on, or near the taxiway, except:
 - (a) On Runways equipped with ILS, taxiway centreline lights located within the ILS critical / sensitive area or the lower edge of the obstacle free zone **should** be colour coded to show alternate green / yellow in both directions. The colour coding **should** commence with a green light close to the Runway centreline and end with a yellow light at the perimeter of the ILS critical / sensitive area or the lower edge of the inner transitional surface, whichever is the furthest from the Runway; thereafter the lights are to show green.
 - (2) Be spaced on a particular section of taxiway (straight or curved) such that a clear indication of the taxiway centreline is provided, particularly on a curved section; and
 - (3) On a straight section of a taxiway be spaced at longitudinal intervals of not more than 30 m, except that:
 - (a) Larger intervals not exceeding 60 m may be used where, because of the prevailing meteorological conditions, adequate guidance is provided by such spacing;
 - (b) Intervals less than 30 m **should** be provided on short straight sections; and
 - (4) On a curved section, be spaced at intervals such that a clear indication of the curve is provided.
 - (a) On a taxiway intended for use in RVR conditions of less than a value of 350 m, the lights on a curve **should not** exceed a spacing of 15 m, and on a curve of less than 400 m radius the lights **should** be spaced at intervals of not greater than 7.5 m. This spacing **should** extend for 60 m before and after the curve.
 - c. On an exit taxiway; the lights **should**:
 - (1) Be fixed lights;
 - (2) Have alternate taxiway centreline lights showing green and yellow from their beginning near the Runway centreline to the perimeter of the ILS critical / sensitive area, or the lower edge of the inner transitional surface, whichever is farthest from the Runway; and thereafter all lights **should** show green. The first light in the exit centreline **should** always show green and the light nearest to the perimeter **should** always show yellow;
 - (3) Where ► Aircraft ◀ follow the same centreline in both directions, show green to ► Aircraft ◀ approaching the Runway;
 - (4) Commence at the point where the taxiway centreline marking begins to curve from the Runway centreline and follow the curved taxiway centreline marking at least to the point where the marking leaves the Runway. The first light **should** be at least 60 cm from any row of Runway centreline lights; and

**Acceptable
Means of
Compliance
3515(16)**

- (5) Be spaced at longitudinal intervals of not more than 7.5 m.
- d. On a rapid exit taxiway; the lights **should**:
- (1) Commence at a point at least 60 m before the beginning of the taxiway centreline curve, and continue beyond the end of the curve to a point on the centreline of the taxiway where an ► **Aircraft** ◀ can be expected to reach normal taxiing speed. The lights on that portion parallel to the Runway centreline **should** be at least 60 cm from any row of Runway centreline lights; and
- (2) Be spaced at longitudinal intervals of not more than 15 m. Where Runway centreline lights are not provided, a greater interval not exceeding 30 m may be used.
78. Taxiway centreline lights **should**: ►
- a. **Be located on the taxiway centreline marking, except that they may be offset by not more than 30 cm where it is not practicable to locate them on the marking; and** ◀
- b. Not be extended to the Runway unless they are interlocked with the stop bar lights.
79. Taxiway centreline lights **should** be in accordance with characteristics specified in RA 3515(29) – (30).

**Guidance
Material
3515(16)**

Taxiway Lights - Taxiway Centreline Lights

80. For operations in RVR less than 350 m, the reduced spacing for curved sections need to extend 60 m before the start and 60 m beyond the end of the curves; for operations in RVR of 350 m or greater, this distance is reduced to 30 m.
81. Taxiway centreline lighting may be considered for the following situations to aid pilot situational awareness:
- a. On a taxiway intended for use at night in RVR conditions of 350 m or greater, and particularly on complex taxiway intersections and exit taxiways;
- b. On an exit taxiway, taxiway, de-icing / anti-icing facility, and Apron in all visibility conditions where specified as components of an advanced surface movement guidance and control system in such a manner as to provide continuous guidance between the Runway centreline and ► **Aircraft** ◀ stands; and
- c. On a Runway forming part of a standard taxi-route where specified as components of an advanced surface movement guidance and control system.

Civil Equivalence.

82. This Regulation is in line with ICAO Annex 14 Vol I Section 5.3.17.

**Regulation
3515(17)**

Taxiway Lights - Taxiway Edge Lights

- 3515(17) HoEs and ADH-Facing Organizations **shall** ensure that taxiway edge lights are provided at the edges of a Runway turn pad, holding bay, de-icing / anti-icing facility and Apron, intended for use at night and on a taxiway not provided with taxiway centreline lights which is intended for use at night. Taxiway edge lights **shall** be provided on a Runway forming part of a standard taxi-route which is intended for taxiing at night.

**Acceptable
Means of
Compliance
3515(17)**

Taxiway Lights - Taxiway Edge Lights

83. Taxiway Edge Lights **should**:
- a. Provide adequate guidance on taxiway layouts, curves and corners and where required additional light units **should** be installed to maintain the visual cues or general layout of a taxiway;
 - b. Be spaced at uniform longitudinal intervals of not more than 60 m on a straight section of a taxiway and on a Runway forming part of a standard taxi-route;
 - c. Be spaced on a curve (where 'R' is the radius of the inner curved line joining the inside light positions):
 - (1) Curves with radius between 350 m and 100 m: R/7;
 - (2) Curves with radius between 100 m and 28 m: Close to but not greater than 14.5 m;
 - (3) Curves with radius below 28 m: R/2, minimum of 4 lights incl. tangent positions for 90° curves.
 - d. Be spaced at uniform longitudinal intervals of not more than 60 m on a holding bay, de-icing / anti-icing facility, Apron, etc.
 - e. Be spaced at uniform longitudinal intervals of not more than 30 m on a Runway turn pad;
 - f. Be located on the pavement as near as possible to the edges of the manoeuvring area, or outside the edges at a distance of not more than 3 m;
 - g. Be placed in pairs one on each side of the taxiway on lines at right angles to the centreline except at junctions;
 - h. Be fixed lights showing blue;
 - i. Show up to at least 75° above the horizontal and at all angles in azimuth necessary to provide guidance to a pilot taxiing in either direction. At an intersection, exit, or curve the lights **should** be shielded as far as possible so that they cannot be seen in angles of azimuth in which they may be confused with other lights; and
 - j. Have a minimum intensity of at least 2 cd from 0° to 6° vertical, and 0.2 cd at any vertical angles between 6° and 75°.
84. Where a Runway turn pad is available, turn pad lights **should** be provided if intended for use at night.
85. Runway turn pad lights **should**:
- a. Normally be located on the Runway turn pad marking, except that they may be offset by not more than 30 cm where it is not practicable to locate them on the marking.
 - b. On a straight section of the Runway turn pad marking, be spaced at longitudinal intervals of not more than 15 m.
 - c. On a curved section of the Runway turn pad marking **should not** exceed a spacing of 7.5 m.
 - d. Be unidirectional fixed lights showing green with beam dimensions such that the light is visible only from ► **Aircraft** ◀ on or approaching the Runway turn pad.
 - e. Be in accordance with the specifications of ICAO Annex 14 Vol 1 Appendix 2, Figure A2-13, A2-14 or A2-15, as appropriate.

**Guidance
Material
3515(17)**

Taxiway Lights - Taxiway Edge Lights

86. Where operationally justified, adequate guidance to ► **Aircraft** ◀ may be achieved by surface illumination or other means.

**Guidance
Material
3515(17)**

87. Taxiway edge lighting may be used to augment taxiway centreline lighting where ►Aircraft◀ are required to negotiate difficult curves. In complex taxiway layout or taxiway with small radius curves, taxiway edge lights may be replaced with taxiway centreline lights.

88. The use of elevated taxiway edge lights may be inappropriate if there is the possibility of damage from jet blast or the operation of ►Aircraft◀ arresting systems.

Civil Equivalence.

89. This Regulation is in line with ICAO Annex 14 Vol I Section 5.3.18.

**Regulation
3515(18)**

Taxiway Lights - Stop Bar Lights

3515(18) HoEs and ADH-Facing Organizations **shall** ensure that stop bar lights are provided at every Runway-holding position serving a precision approach Runway Category II or III.

**Acceptable
Means of
Compliance
3515(18)**

Taxiway Lights - Stop Bar Lights

90. Stop Bar lights **should** be provided at all Runway-Holding Positions and Intermediate-Holding Positions intended for use in RVR conditions less than ►550 m,◀ except where:

- a. Appropriate aids and procedures are available to assist in preventing inadvertent incursions of traffic onto the Runway; or
- b. Operational procedures exist to limit the number of:
 - (1) ►Aircraft◀ on the manoeuvring area, or on final approach within 5 nm, to one at a time; and
 - (2) Vehicles on the manoeuvring area to the essential minimum.

91. The Stop Bar installation **should**:

- a. Consist of lights spaced at intervals of 3 m across the taxiway, showing red in the intended direction(s) of approach to the intersection or Runway-holding position;
- b. At a Runway-holding position, be unidirectional, and **should** show red in the direction of approach to the Runway;
- c. At intermediate-holding positions be bi-directional where the holding position is intended for use in each direction;
- d. At Runway-holding positions and intermediate-holding positions be independently switchable. All other stop bars protecting Runway access points **should** be permanently illuminated during Low Visibility Operations;
- e. Be positioned co-incident with any associated Runway-holding position marking so as not to obscure or interfere with the integrity of the marking;
- f. Have the outer lights located on the edges of the taxiway;
- g. Where the flight crew's view of the Stop Bar might be obscured, be extended beyond the edge of the taxiway by the addition of four omni-directional elevated lights, two placed on each side of the taxiway along the stop-bar axis at intervals equal to the spacing of other lights making up the Stop Bar;
- h. Be positioned no closer to a manoeuvring area than the requirements of RA 3511⁴;
- i. Be iaw characteristics specified in RA 3515(29) – (30); and
- j. Where there is more than one stop bar associated with a taxiway / Runway intersection, have only one illuminated at any given time.

92. The lighting circuit for Stop Bars **should** be designed so that:

⁴ Refer to RA 3511 - Permanent Fixed Wing Aerodrome - Physical Characteristics.

**Acceptable
Means of
Compliance
3515(18)**

- a. Stop bars located across entrance taxiways are selectively switchable;
- b. Stop bars located across taxiways intended to be used only as exit taxiways are switchable selectively or in groups;
- c. When a stop bar is illuminated, any taxiway centreline lights installed beyond the stop bar **should** be extinguished for a distance of at least 90 m; and
- d. Where a Stop bar is independently switchable, it **should** be interlocked with the taxiway centreline lights so that when the centreline lights beyond the stop bar are illuminated the stop bar is extinguished and vice versa.

**Guidance
Material
3515(18)**

Taxiway Lights - Stop Bar Lights

93. Runway incursions may take place in all visibility or weather conditions. The provision of stop bars at Runway holding positions and their use at night and in visibility conditions greater than ►550 m◀ RVR can form part of effective Runway incursion prevention measures.

Civil Equivalence.

94. This Regulation is in line with ICAO Annex 14 Vol I para 5.3.20.

**Regulation
3515(19)**

Taxiway Lights - Runway Guard Lights

3515(19) HoEs and ADH-Facing Organizations **shall** ensure that Runway Guard Lights are provided at each taxiway / Runway intersection associated with a Runway intended for use in RVR conditions less than a value of 550 m where a stop bar is not installed; and RVR conditions of values between 550 m and 1200 m where the traffic density is heavy.

**Acceptable
Means of
Compliance
3515(19)**

Taxiway Lights - Runway Guard Lights

95. Runway Guard Lights **should** (iaw Figure 7, Configuration A):
 - a. Be located at each side of the taxiway and at the same distance as the Runway-holding position marking;
 - b. Consist of two pairs of yellow lights illuminated alternately between 30 and 60 cycles per minute. The light suppression and illumination periods **should** be equal and opposite in each light;
 - c. Not exceed a height above which their presence may endanger ►Aircraft,◀
 - d. Meet the frangibility requirements of RA 3515(29);
 - e. Be unidirectional and aligned to be visible to the pilot of an ►Aircraft◀ taxiing to the holding position;
 - f. Have intensity in yellow light and beam spreads of lights iaw RA 3515(29) and (30);
 - g. Where intended for use during the day, have intensity in yellow light and beam spreads iaw the specifications of RA 3515(29) – (30); and
 - h. Be switched independently of any stop bar lights.
96. Runway Guard Lights **should** (iaw Figure 7 Configuration B):
 - a. Either in conjunction with Configuration A or separately, be provided at each taxiway / Runway intersection where enhanced conspicuity of the taxiway / Runway intersection is needed, such as on a wide-throat taxiway, except that Configuration B **should not** be collocated with a stop bar;
 - b. Be located across the taxiway and at the same distance as the Runway-holding position marking;
 - c. Consist of yellow lights spaced at intervals of 3 m across the taxiway with adjacent lights alternately illuminated and alternative lights illuminated in unison

**Acceptable
Means of
Compliance
3515(19)**

at a rate of 30 to 60 cycles per minute. The light suppression and illumination periods **should** be equal and opposite in each light;

- d. Be unidirectional and aligned to be visible to the pilot of an ► Aircraft ◀ taxiing to the holding position;
- e. Have intensity in yellow light and beam spreads of lights iaw RA 3515(29) and (30);
- f. Where intended for use during the day, have intensity in yellow light and beam spreads iaw the specifications of RA 3515(29) – (30); and
- g. Be switched independently of any stop bar lights.

Figure 7. Runway Guard Lights

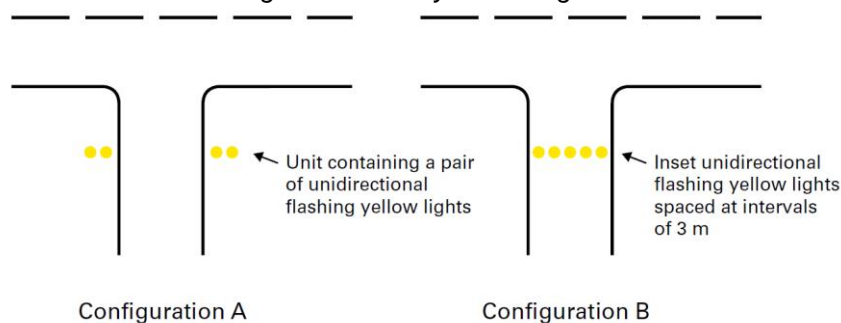

**Guidance
Material
3515(19)**

Taxiway Lights - Runway Guard Lights

97. Where there is a need to enhance the contrast between the on and off state of Runway guard lights, Configuration A, intended for use during the day, a visor of sufficient size to prevent sunlight from entering the lens without interfering with the function of the fixture may be located above each lamp.

98. The optimum flash rate is dependent on the rise and fall times of the lamps used. Runway guard lights, Configuration A, installed on 6.6 ampere series circuits have been found to look best when operated at 45 to 50 flashes per minute per lamp. Runway guard lights, Configuration B, installed on 6.6 ampere series circuits have been found to look best when operated at 30 to 32 flashes per minute per lamp.

99. Where Runway guard lights are operated in good visibility conditions at night, the luminous intensity may be reduced to 30% but the signal characteristics need to be retained.

Civil Equivalence.

100. This Regulation is in line with ICAO Annex 14 Vol I para 5.3.23.

**Regulation
3515(20)**

Taxiway Lights - Road-Holding Position Lights

3515(20) HoEs and ADH-Facing Organizations **shall** ensure that road-holding position lights are provided at the intersection of all roads with Runways.

**Acceptable
Means of
Compliance
3515(20)**

Taxiway Lights - Road-Holding Position Lights

101. Road-Holding position lights **should**:

- a. Be located 1.5 m from the edge of the left-hand side of the road (or iaw local traffic regulations), at a suitable height, and adjacent to the road-holding position marking as described in RA 3514(5)⁵;
- b. Comprise a controllable red (stop) / green (go) traffic light or a flashing red light and steady green:
 - (1) The lights **should** be controlled by the ATC controller; and

⁵ Refer to RA 3514(5): ► ◀ Vehicle Roadway Markings.

**Acceptable
Means of
Compliance
3515(20)**

- (2) The system **should** provide an alarm to the ATC controller in the event of a failure of a single red signal.
- c. Be unidirectional and aligned to be visible to the driver of a vehicle approaching the holding position;
- d. Have an intensity of the light beam adequate for the conditions of visibility and ambient light in which the use of the holding position is intended but **should not** dazzle the driver; and
- e. Have a flash frequency of the flashing red light between 30 and 60 flashes per minute;
- f. Be accompanied by a road-holding position sign.

**Guidance
Material
3515(20)**

**Taxiway Lights - Road-Holding Position Lights
Civil Equivalence.**

102. This Regulation is in line with ICAO Annex 14 Vol I Section 5.3.28.

**Regulation
3515(21)**

Apron Lights - Edge Lighting

3515(21) HoEs and ADH-Facing Organizations **shall** ensure that the edges of Aprons including ► **Aircraft** ◀ servicing platforms and operational readiness platforms intended to be used at night are marked with blue edge lights.

**Acceptable
Means of
Compliance
3515(21)**

Apron Lights - Edge Lighting

103. The edges of ► **Aircraft** ◀ Aprons, ► **Aircraft** ◀ servicing platforms and operational readiness platforms **should** be marked with blue edge lights iaw the specifications given for taxiway edge lights given in RA 3515(17).

**Guidance
Material
3515(21)**

Apron Lights - Edge Lighting

104. Nil.

**Regulation
3515(22)**

Apron Lights - Floodlighting

3515(22) HoEs and ADH-Facing Organizations **shall** ensure that floodlighting is provided on an Apron, on a de-icing / anti-icing facility and on a designated ► **Aircraft** ◀ parking position intended to be used at night.

**Acceptable
Means of
Compliance
3515(22)**

Apron Lights - Floodlighting

105. Apron floodlighting **should**:
- a. Be located to provide adequate illumination on all Apron service areas, with a minimum of glare to pilots of ► **Aircraft** ◀ in flight and on the ground, Aerodrome and Apron controllers, and personnel on the Apron;
- b. Be arranged such that an ► **Aircraft** ◀ stand receives light from two or more directions to minimize shadows;
- c. Have a spectral distribution such that the colours used for ► **Aircraft** ◀ marking connected with routine servicing, and for surface and obstacle marking, can be correctly identified;
- d. Have an average illuminance for an ► **Aircraft** ◀ stand of at least:
- (1) Horizontal illuminance — 20 lux with a uniformity ratio (average to minimum) of not more than 4 to 1; and

Acceptable Means of Compliance 3515(22)

(2) Vertical illuminance — 20 lux at a height of 2 m above the Apron in relevant directions; and

e. Have an average illuminance for other Apron areas of at least 50 % horizontal and vertical illuminance of the average illuminance on the ► Aircraft ◀ stands with a uniformity ratio (average to minimum) of not more than 4 to 1.

Guidance Material 3515(22)

Apron Lights - Floodlighting Civil Equivalence.

106. This Regulation is in line with ICAO Annex 14 Vol I Section 5.3.24.

Regulation 3515(23)

Miscellaneous Lights - Undercarriage Inspection Systems

3515(23) HoEs and ADH-Facing Organizations **shall** ensure that an undercarriage inspection system is provided where there may be an operational requirement to view the undercarriage of an ► Aircraft ◀ during periods of darkness.

Acceptable Means of Compliance 3515(23)

Miscellaneous Lights - Undercarriage Inspection Systems

107. An Undercarriage Check Lighting System **should**:

- a. Have a layout as per Figure 8;
- b. Have light units set horizontal longitudinally and aimed vertically upwards with the outer rows toed in by 2°; and

108. An Undercarriage Check Flare-path **should**:

- a. Be installed on Royal Air Force and Royal Navy Aerodromes as depicted in Figure 8;
- b. Consist of 14 flare-path sodiums, eight forming the cluster, with a lead-in and lead-out of three sodiums for accurate line-up;
- c. Be sited on the airfield in a convenient position to enable the ► Aircraft ◀ undercarriage to be checked from the visual control positions without disrupting or hazarding ► Aircraft ◀ in the circuit area.

Figure 8. Undercarriage Inspection System Lights

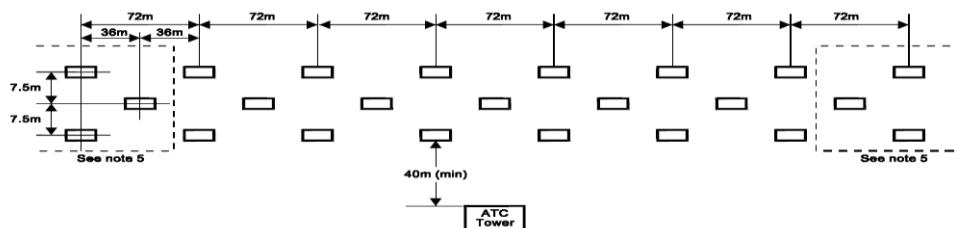

Note: ATC Tower and Centre of System to Coincide.

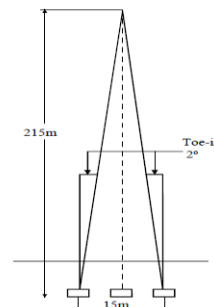

► Figure 8, Note 5: Refer to paragraph 110. ◀

Acceptable Means of Compliance 3515(23)

Undercarriage Check Flarepath – Layout and Optical Requirements

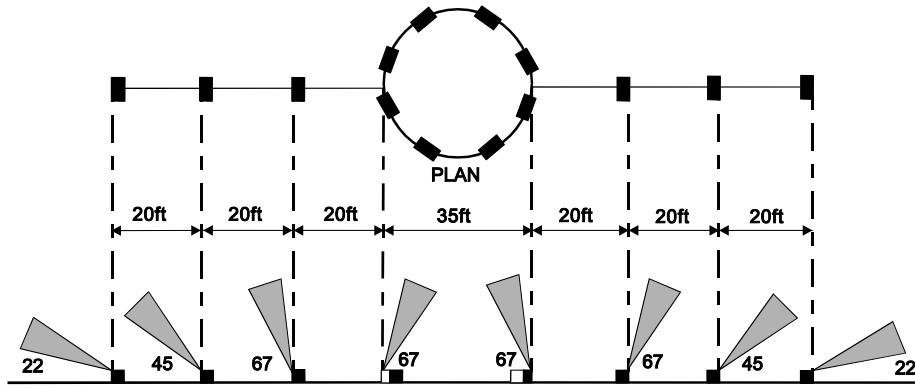

Guidance Material 3515(23)

Miscellaneous Lights - Undercarriage Inspection Systems

109. The undercarriage inspection system is designed to allow clear night viewing of the undercarriage of an ► Aircraft ◀ flying at 200 kt and 215 m above ground level.

110. Exceptionally, where ► Aircraft ◀ speeds through the system will not exceed 120 kt, an abbreviated system may be installed by omitting 3 light units ► and their associated cabling ◀ from each end. ► Other phasing and cabling will remain as shown to allow for possible future extension to the full system. ◀

Regulation 3515(24)

Miscellaneous Lights - Arrestor Cable Systems and Illuminated Runway Distance to go Markers

3515(24) HoEs and ADH-Facing Organizations shall ensure that Arrestor Cable System Markers and Runway Distance to go Markers (RDM) installed iaw RA 3517(9) – (10)⁶ are illuminated for use at night or in low visibility operations.

Acceptable Means of Compliance 3515(24)

Miscellaneous Lights - Arrestor Cable Systems and Illuminated Runway Distance to go Markers

111. Illuminated Arrestor Cable Markers and IRDM should:

- a. For an instrument approach Runway, have an average luminance of at least 150 cd/m² for yellow and 300 cd/m² for white at maximum brilliancy;
- b. For a non-instrument Runway, have an average luminance of at least 50 cd/m² for yellow and 100 cd/m² for white at maximum brilliancy;
- c. Have the ratio between the maximum and the minimum luminance value over the whole sign face no greater than 5:1;
- d. Have marker characteristics iaw RA 3517(9-10).

Guidance Material 3515(24)

Miscellaneous Lights - Arrestor Cable Systems and Illuminated Runway Distance to go Markers

112. Average luminance is obtained as detailed in ICAO Annex 14, Volume 1, Appendix 4.

⁶ Refer to RA 3517 ► (9): Arrestor System Markers and RA 3517(10): Distance To Go Markers. ◀

**Regulation
3515(25)**

Miscellaneous Lights - Visual Docking Guidance System

3515(25) HoEs and ADH-Facing Organizations **shall** ensure that a Visual Docking Guidance System (VDGS) is provided when it is intended to indicate, the precise positioning of an ►Aircraft◀ on an ►Aircraft◀ stand when other alternative means, such as marshallers, are not practicable.

**Acceptable
Means of
Compliance
3515(25)**

Miscellaneous Lights - Visual Docking Guidance System

113. VDGS facilities **should** be as detailed in ICAO Annex 14, Volume I, Chapter 5, Section 3.25.

**Guidance
Material
3515(25)**

Miscellaneous Lights - Visual Docking Guidance System

114. Nil.

**Regulation
3515(26)**

Miscellaneous Lights - Advanced Visual Docking Guidance System

3515(26) HoEs and ADH-Facing Organizations **shall** ensure that an Advanced VDGS (A-VDGS) is provided where it is operationally desirable to confirm the correct ►Aircraft◀ type for which guidance is being provided and / or to indicate the stand centreline in use, where more than one is provided for.

**Acceptable
Means of
Compliance
3515(26)**

Miscellaneous Lights - Advanced Visual Docking Guidance System

115. A-VDGS facilities **should** be as detailed in ICAO Annex 14, Volume I, Chapter 5, Section 3.26.

**Guidance
Material
3515(26)**

Miscellaneous Lights - Advanced Visual Docking Guidance System

116. Nil.

**Regulation
3515(27)**

Miscellaneous Lights - Emergency Portable Lighting

3515(27) HoEs and ADH-Facing Organizations **shall** ensure that, at an Aerodrome provided with Runway lighting and without a secondary power supply, sufficient emergency lights be conveniently available for installation on at least the primary Runway in the event of failure of the normal lighting system.

**Acceptable
Means of
Compliance
3515(27)**

Miscellaneous Lights - Emergency Portable Lighting

117. When Emergency Portable Lighting is laid out iaw Figure 9 it **should** provide adequate guidance to ►Aircraft◀ on instrument approaches in visibility down to 800 m.

118. Portable obstacle lights **should** provide adequate visual guidance to ►Aircraft◀ taxiing in normal operating conditions. When ►Aircraft◀ taxi-lights are being used, the taxiway may be delineated with airfield retro-reflective markers or centreline studs.

Acceptable Means of Compliance 3515(27)

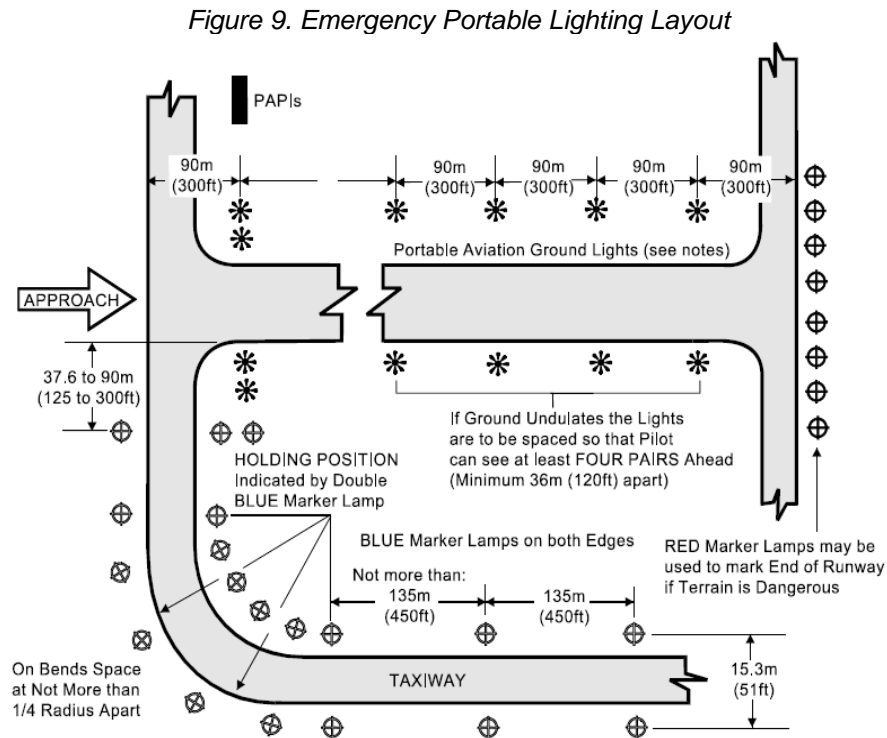

Guidance Material 3515(27)

Miscellaneous Lights - Emergency Portable Lighting

119. Emergency Portable Lighting comprises omni-directional Runway edge lights (ORELs); uni-directional approach lights (UAL); tactical PAPiS (TAC PAPiS) and NVD compatible PAPiS.

120. Portable Obstacle Lights – Marker Lamps. Portable obstacle lights fitted with blue filters need to be used to augment or provide taxiway lighting on parts of the movement area not equipped with permanent lighting. Portable obstacle lights fitted with red filters need to be used to mark obstacles.

121. Where appropriate, emergency portable Aerodrome lighting equipment may be used as a standby to cover temporary failures in permanent installations or alternatively used to maintain visual cues during construction works. There is no requirement to lay emergency portable lighting at Military airfields on a routine basis.

122. Chance Lights. If available, a chance light or mobile floodlight can be held ready to assist in illuminating the Runway in an emergency.

123. Solar light units.

a. These light units may be used to provide taxiway edge lighting, complying with the characteristics defined for taxiway edge lighting in RA 3515(17). They may be provided adjacent to existing taxiway edge light units.

b. Where appropriate, solar portable Aerodrome lighting equipment may be used after a suitable and sufficient Safety Assessment to cover temporary failures in permanent installations or alternatively used to maintain visual cues during construction works. Solar light units, where used, need to meet the specification of the permanent light units.

Civil Equivalence.

124. This Regulation is in line with ICAO Annex 14 Vol I Section 5.3.2.

Regulation 3515(28)

Aeronautical Ground Lights Characteristics - Construction

3515(28) HoEs and ADH-Facing Organizations **shall** ensure that all AGL fittings are of construction and height that their presence does not endanger ► Aircraft. ◀

**Acceptable
Means of
Compliance
3515(28)**

Aeronautical Ground Lights Characteristics - Construction

125. Elevated Approach Lights and their supporting structure **should**:
- a. Be frangible except that, in that portion of the approach lighting system beyond 300 m from the threshold:
 - (1) Where the height of a supporting structure exceeds 12 m, the frangibility requirement **should** apply to the top 12 m only; and
 - (2) Where a supporting structure is surrounded by non-frangible objects, only that part of the structure that extends above the surrounding objects **should** be frangible;
 - b. When an approach light fixture or supporting structure is not in itself sufficiently conspicuous, be suitably marked; and
 - c. When an approach light fixture or supporting structure is not in itself sufficiently conspicuous, be suitably marked.
126. Elevated Runway, stopway, and taxiway lights **should**:
- a. Be frangible;
 - b. Be sufficiently low to preserve clearance for propellers and for the engine pods of jet ► **Aircraft** ◄;
 - c. Be conspicuous within the manoeuvring area;
 - d. Be no greater in height than 0.36 m above the adjacent pavement level;
 - e. In stopways and clearways used for routine manoeuvring, be flush with the ground;
 - f. In stopways and clearways not used for routine manoeuvring, be no greater than:
 - (1) 0.46 m above ground level in stopways; and
 - (2) 0.9 m above ground level in clearways.
127. Surface Lights inset in the surface of Runways, stopways, taxiways, and Aprons **should**:
- a. Be designed and fitted to withstand being run over by the wheels of an ► **Aircraft** ◄ without damage either to the ► **Aircraft** ◄ or to the lights themselves; and
 - b. **Should not** project above the surrounding surface greater than:
 - (1) 16 mm within 7.5 m either side of the Runway centreline except that inset approach lights in this area and taxiway lights crossing a Runway or leading to a Runway centreline may project 25 mm;
 - (2) 19 mm between 7.5 m from the Runway centreline to 3 m from the Runway edge except that inset approach lights in these areas may project 32 mm and taxiway lights crossing or leading to a Runway centreline may project 25 mm;
 - (3) 38 mm within 6 m of the Runway end or within 3 m of the Runway edge;
 - (4) 32 mm for displaced threshold lights; and
 - (5) 25 mm in taxiway surfaces;
 - c. Be secured in the surface to prevent accidental extraction; and
 - d. Not produce, at the interface between the inset light and an ► **Aircraft** ◄ tyre, by conduction or radiation, a temperature greater than 160° C during a 10 minute period of exposure.

**Guidance
Material
3515(28)**

Aeronautical Ground Lights Characteristics - Construction

128. No deviations present in the main beam pattern when the lighting fixture is properly aimed. The light unit needs to be installed so that the main beam is aligned within 0.5° of the specified requirements.

129. All AGL must conform to Electromagnetic Compatibility Directive 2014/30/EU in that lights must:

- a. Not cause radiated or conducted electromagnetic interference to other electrical systems that may be located on or near the Aerodrome, or that may use the same power supply; and
- b. Have immunity to electromagnetic phenomena and electromagnetic fields, such as from radio transmitters, transients on power lines, atmospheric discharges etc.

130. Have immunity to electromagnetic phenomena and electromagnetic fields, such as from radio transmitters, transients on power lines, atmospheric discharges etc.

Civil Equivalence.

131. This Regulation is in line with ICAO Annex 14 Vol I Sections 5.3.1.4 – 5.3.1.8.

**Regulation
3515(29)**

Aeronautical Ground Lights Characteristics - Intensity and Distribution

3515(29) HoEs and ADH-Facing Organizations **shall** ensure that the intensity and distribution of Runway lighting is adequate for the minimum conditions of visibility and ambient light in which use of the Runway is intended and be compatible with that of the nearest section of the approach lighting system when provided.

**Acceptable
Means of
Compliance
3515(29)**

Aeronautical Ground Lights Characteristics - Intensity and Distribution

132. Intensity and distribution of AGL **should** be as detailed in ICAO Annex 14, Volume I, Appendix 2.

133. Where a high-intensity lighting system is provided, a suitable intensity control **should** be incorporated to allow for adjustment of the light intensity to meet the prevailing conditions. Separate intensity controls or other suitable methods **should** be provided to ensure that the following systems, when installed, can be operated at compatible intensities:

- a. Approach Lighting System;
- b. Runway Edge Lights;
- c. Runway Threshold Lights;
- d. Runway End Lights;
- e. Runway Centreline Lights;
- f. Runway Touchdown Zone Lights; and
- g. Taxiway Centreline Lights.

134. On the perimeter of and within the ellipse defining the main beam in ICAO Annex 14 Vol 1 Appendix 2, Figures A2-1 to A2-10, the maximum light intensity value **should not** be greater than three times the minimum light intensity value measured iaw Appendix 2, collective notes for Figures A2-1 to A2-11 and A2-26.

135. On the perimeter of and within the rectangle defining the main beam in ICAO Annex 14 Vol 1 Appendix 2, Figures A2-12 to A2-20, the maximum light intensity value **should not** be greater than three times the minimum light intensity value measured iaw Appendix 2, collective notes for Figures A2-12 to A2-21.

**Guidance
Material
3515(29)****Aeronautical Ground Lights Characteristics - Intensity and Distribution**

136. AGL needs to have immunity to electromagnetic phenomena and electromagnetic fields, such as from radio transmitters, transients on power lines, atmospheric discharges etc.

**Regulation
3515(30)****Aeronautical Ground Lights Characteristics - Colour and Discrimination**

3515(30) HoEs and ADH-Facing Organizations **shall** ensure that the colour and discrimination of AGL is such that the possibility of confusion of colours is minimized.

**Acceptable
Means of
Compliance
3515(30)****Aeronautical Ground Lights Characteristics - Colour and Discrimination**

137. Colour and discrimination requirements for all AGL **should** be as detailed in ICAO Annex 14, Volume I, Appendix 1.

**Guidance
Material
3515(30)****Aeronautical Ground Lights Characteristics - Colour and Discrimination**

138. Nil.

Intentionally Blank for Print Pagination

RA 3516 - Permanent Fixed Wing Aerodrome - Signs

Rationale

When moving around the Aerodrome it is essential that personnel are made aware of Safety related information or instructions aimed at reducing the number of Runway incursions or similar hazardous incidents. Aerodrome signs are used to convey this Safety related information to the operating community.

Contents

3516(1): General

3516(2): Mandatory Instruction Signs

3516(3): Information Signs

3516(4): Aerodrome Access Boards

Regulation

3516(1)

General

3516(1) Heads of Establishments (HoEs) and Aviation Duty Holder-Facing Organizations (ADH-Facing Organizations) **shall** ensure that signs are provided to convey a mandatory instruction, information on a specific location or destination on a Movement Area, or to provide other information.

Acceptable Means of Compliance 3516(1)

General

1. Aerodrome Signs **should**:
 - a. Be frangible;
 - b. Be positioned sufficiently low to preserve clearance for propellers and the engine pods of jet ► **Aircraft** ◀ when located near a Runway or taxiway;
 - c. When installed, have a height no greater than the dimensions shown in Table 1;
 - d. Be rectangular, as shown in Figures 1 and 2 with the longer side horizontal;
 - e. Only be red for mandatory instruction signs;
 - f. Have inscriptions in accordance with (iaw) the provisions of Figures 3 and 4;
 - g. Be illuminated iaw the provisions of International Civil Aviation Organization (ICAO) Annex 14 Vol I Appendix 4 when intended for use:
 - (1) In Runway visual range conditions less than a value of 800 m; or
 - (2) At night in association with instrument Runways; or
 - (3) At night in association with non-instrument Runways where the code number is 3 or 4.
 - h. Be retro - reflective and / or illuminated iaw the provisions of ICAO Annex 14 Vol I Appendix 4 when intended for use at night in association with non-instrument Runways where the code number is 1 or 2;
 - i. Have colour and discrimination requirements for all objects as detailed in ICAO Annex 14, Vol I, Appendix 1;
 - j. Have character sizes iaw ICAO Annex 14 Vol I Appendix 4.

Acceptable Means of Compliance 3516(1)

Table 1. Location distances for taxiing guidance signs including Runway exit signs

| Code number | Legend | Sign height (mm) | | Perpendicular distance from defined taxiway pavement edge to near side of sign | Perpendicular distance from defined Runway pavement edge to near side of sign |
|-------------|--------|------------------|------------------|--|---|
| | | Face (min.) | Installed (max.) | | |
| 1 or 2 | 200 | ▶300◀ | 700 | 5-11 m | 3-10 m |
| 1 or 2 | 300 | ▶450◀ | 900 | 5-11 m | 3-10 m |
| 3 or 4 | 300 | ▶450◀ | 900 | 11-21 m | 8-15 m |
| 3 or 4 | 400 | ▶600◀ | 1 100 | 11-21 m | 8-15 m |

Figure 1. Intermediate holding signs

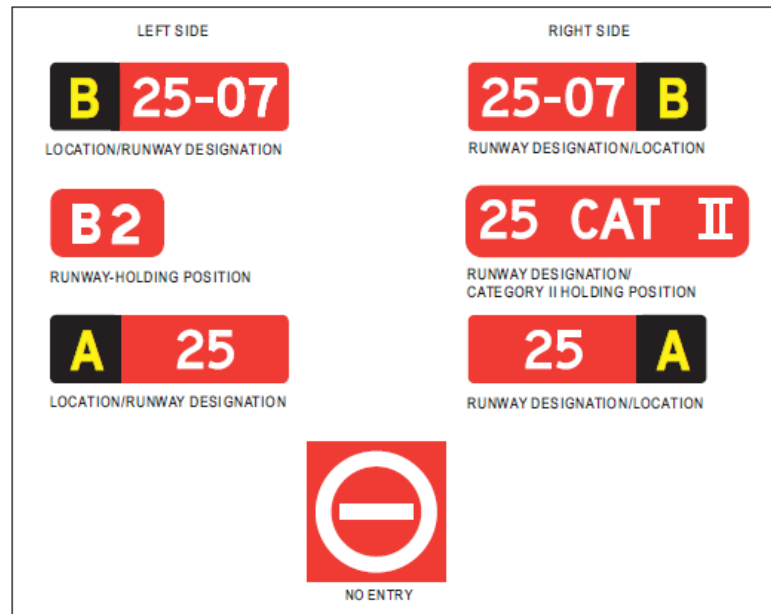
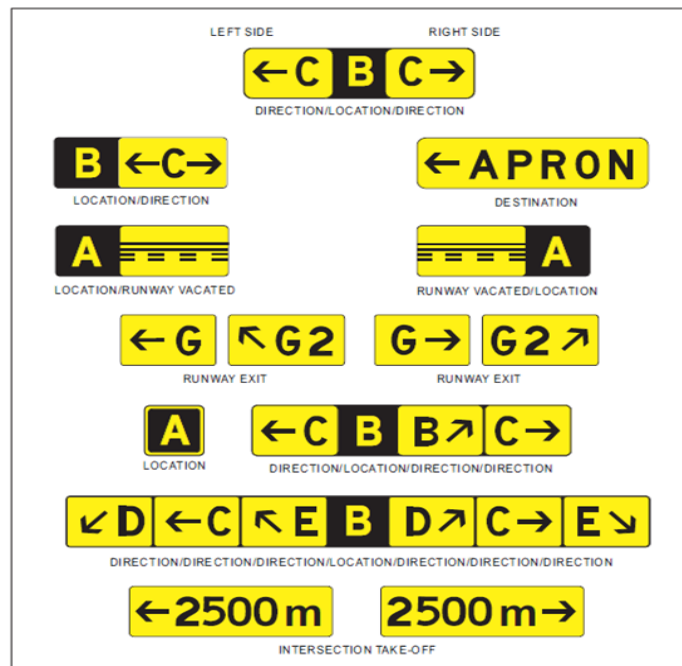

Figure 2. Airfield Sign Layout



Acceptable
Means of
Compliance
3516(1)

Figure 3a. Airfield Inscriptions

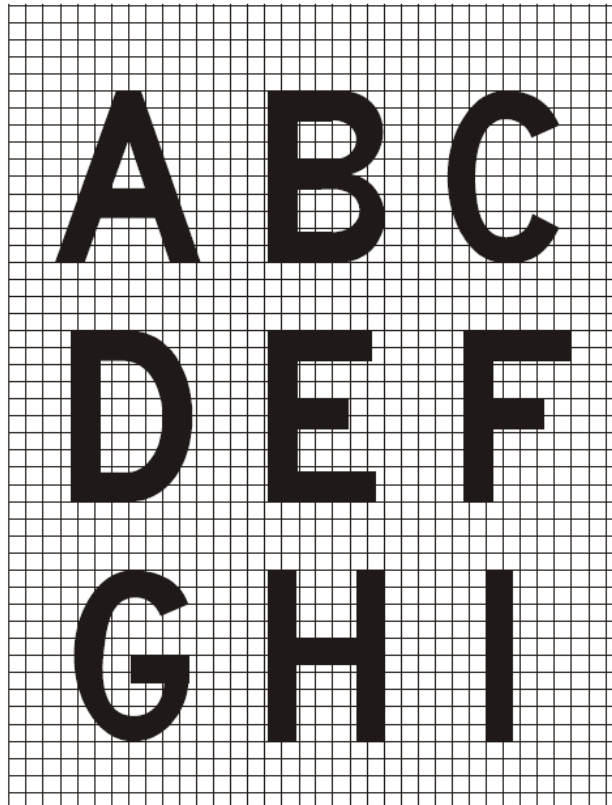
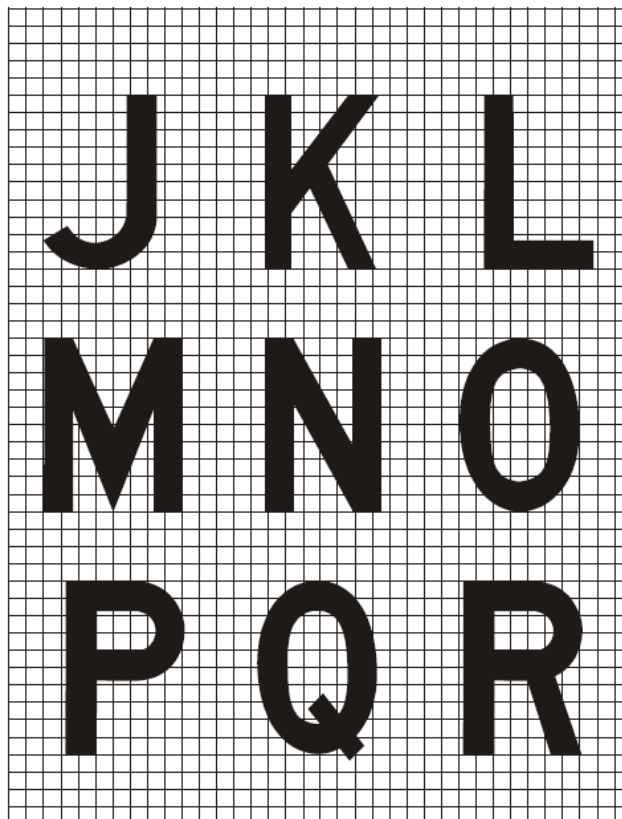

Figure 3b. Airfield Inscriptions



Acceptable
Means of
Compliance
3516(1)

Figure 3c. Airfield Inscriptions

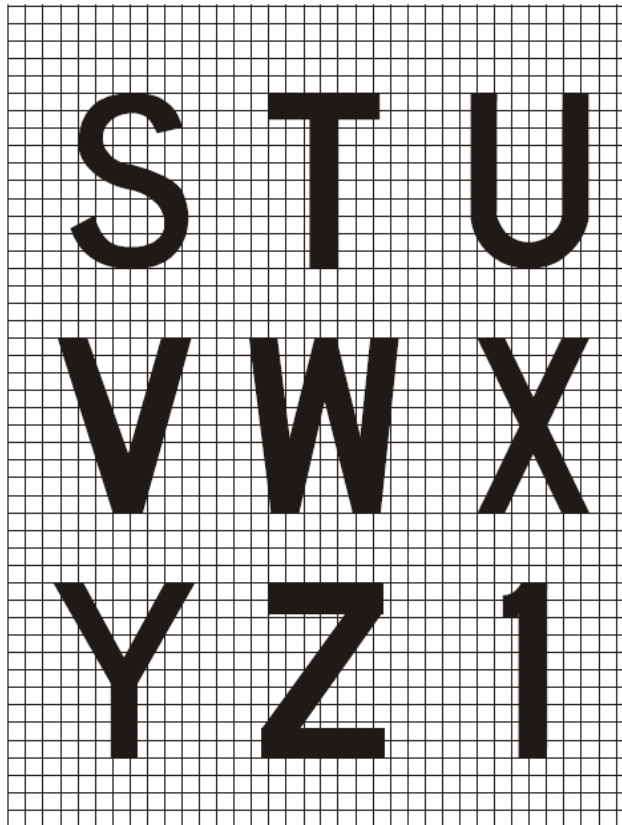
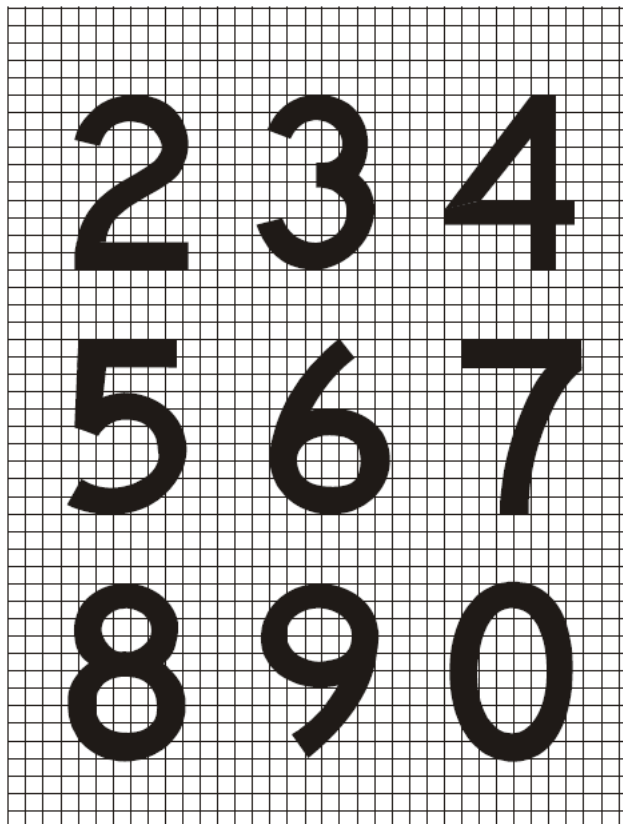

Figure 3d. Airfield Inscriptions



Acceptable
Means of
Compliance
3516(1)

Figure 3e. Airfield Inscriptions

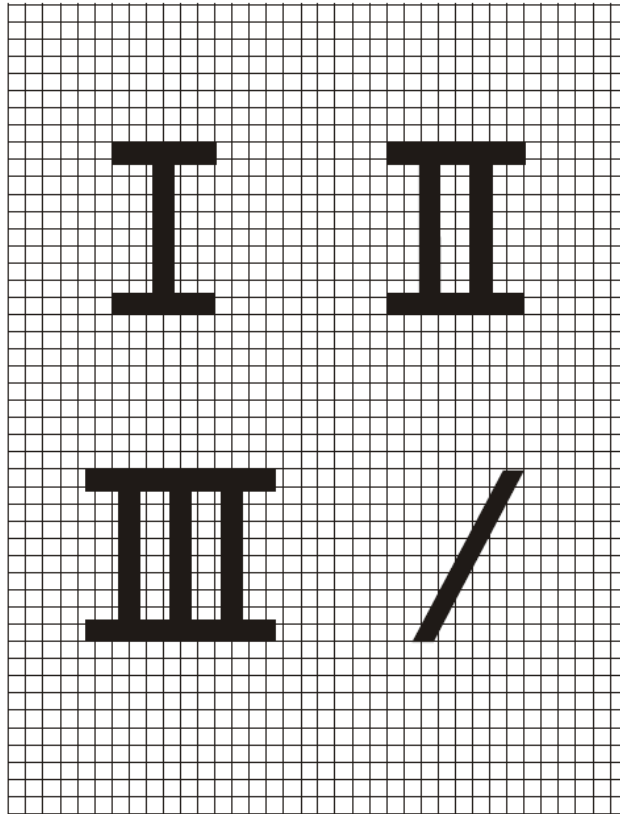

Figure 3e. Airfield Inscriptions - Runway Vacated Sign

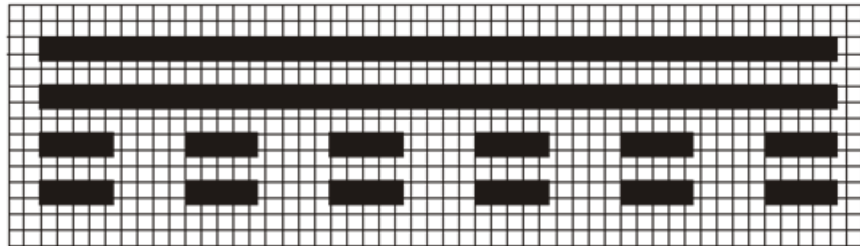
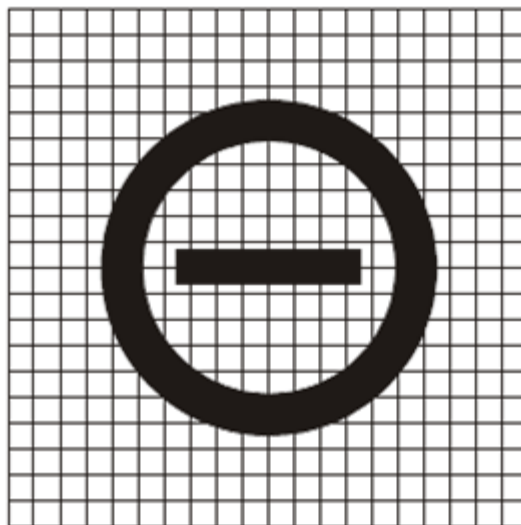
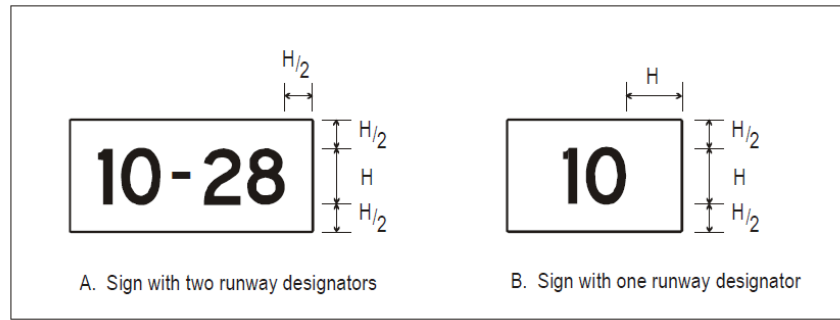

Figure 3f. Airfield Inscriptions - NO ENTRY sign



**Acceptable
Means of
Compliance
3516(1)**

Figure 4. Airfield Inscription Dimensions



**Guidance
Material
3516(1)**

General

Civil Equivalence.

2. This regulation is in line with ICAO Annex 14 Vol I Section 5.4.1.

**Regulation
3516(2)**

Mandatory Instruction Signs

- 3516(2) HoEs and ADH-Facing Organizations **shall** ensure that a mandatory instruction sign is provided to identify a location beyond which an ► Aircraft ◀ taxiing, or vehicle is not to proceed unless authorized by Air Traffic Control (ATC).

**Acceptable
Means of
Compliance
3516(2)**

Mandatory Instruction Signs

3. Mandatory instruction signs **should** include Runway designation signs, Category I, II, or III holding position signs, Runway-holding position signs, road-holding position signs, and NO ENTRY signs.
4. A mandatory instruction sign **should** consist of an inscription in white on a red background.
5. Internally lit mandatory signs **should** be provided with an alternative power source in accordance with the requirements of RA 3520¹.
6. Runway designation signs **should**:
 - a. Be supplemented with a pattern 'A' Runway-holding position marking, as shown in RA 3514² Figure 6, at a taxiway / Runway intersection or a Runway / Runway intersection;
 - b. At a taxiway / Runway intersection or a Runway / Runway intersection, be located on each side of the Runway-holding position marking facing the direction of approach to the Runway;
 - c. Have an inscription consisting of the Runway designations of the intersecting Runway properly oriented with respect to the viewing position of the sign; and
 - d. When installed in the vicinity of a Runway extremity, show the Runway designation of the concerned Runway extremity only.
7. Category I / II / III Holding Position Signs **should**:
 - a. Be supplemented with a pattern 'B' Runway-holding position marking, as shown in RA 3514 Figure 6;
 - b. For a Category I, II, or III holding position sign, be located on each side of the Runway-holding position marking facing the direction of the approach to the critical area; and

¹ Refer to RA 3520 – Permanent Fixed Wing Aerodrome - Aerodrome Electrical Systems.

² Refer to RA 3514 – Permanent Fixed Wing Aerodrome - Markings.

**Acceptable
Means of
Compliance
3516(2)**

- c. Have an inscription on a Category I, II, III, or joint II / III holding position sign consisting of the Runway designator followed by CAT I, CAT II, CAT III, or CAT II / III as appropriate.
8. Runway Holding Position Signs **should**:
- a. Supplement a pattern 'A' Runway holding position marking, as shown in RA 3514 Figure 6, at a Runway holding position;
- b. Be located on each side of the Runway holding position established iaw RA 3511³ Table 7 facing the approach to the Obstacle Limitation Surface or Instrument Landing System (ILS) / Microwave Landing System (MLS) critical / sensitive area as appropriate; and
- c. Have an inscription consisting of the taxiway designation and a number at a Runway holding position established iaw RA 3511 Table 7.
9. Road Holding Position Signs **should**:
- a. Be provided at all road entrances to a Runway or a taxiway;
- b. Be located 1.5 m from one edge of the road (left or right as appropriate to the local road traffic regulations) at the holding position; and
- c. Have an inscription that conforms to the local road traffic regulations and include the following:
- (1) A Stop Sign.
 - (2) A location designator.
10. NO ENTRY Signs **should**:
- a. Be provided when entry into an area is prohibited, on both sides of the road;
- b. Be located at the beginning of the area to which entrance is prohibited on each side of the taxiway as viewed by the pilot; and
- c. Have an inscription iaw Figure 3f.

**Guidance
Material
3516(2)**

Mandatory Instruction Signs

11. Where, owing to environmental or other factors, the conspicuity of the inscription on a mandatory instruction sign needs to be enhanced, the outside edge of the white inscription may be supplemented by a black outline measuring 10 mm in width for Runway code numbers 1 and 2, and 20 mm in width for Runway code numbers 3 and 4.
12. Where diagonal lines are used on airfield signs, as illustrated at Figure 2, the stroke width of the diagonal will be equal to $\frac{3}{4}$ of the stroke of the character. The size of the break between the diagonal and the character will be approximately $\frac{1}{2}$ the character stroke width.
13. Road holding position signs may also be provided at road entrances to taxiways.
14. Where appropriate, road holding position signs may state a requirement to obtain ATC clearance.

Civil Equivalence.

15. This regulation is in line with ICAO Annex 14 Vol I Section 5.4.2.

**Regulation
3516(3)**

Information Signs

- 3516(3) HoEs and ADH-Facing Organizations **shall** ensure that an information sign is provided where there is an operational need to identify a specific location or routing information.

³ Refer to RA 3511 – Permanent Fixed Wing Aerodrome – Physical Characteristics.

**Acceptable
Means of
Compliance
3516(3)****Information Signs**

16. Information signs **should** include, but are not limited to:
 - a. Direction signs.
 - b. Location signs.
 - c. Destination signs.
 - d. Runway exit signs.
 - e. Runway vacated signs.
 - f. Intersection take-off signs.
17. An information sign other than a location sign **should** consist of an inscription in black on a yellow background.
18. A location sign **should** consist of an inscription in yellow on a black background and where it is a stand-alone sign, **should** have a yellow border.
19. Except as specified in sub-para 21.b, information signs **should** wherever practicable, be located on the left-hand side of the taxiway iaw Table 1.
20. An information sign other than a location sign **should not** be collocated with a mandatory instruction sign.
21. A Runway exit sign **should**:
 - a. Be provided where there is an operational need to identify a Runway exit;
 - b. Be located on the same side of the Runway as the exit is located (ie left or right), and positioned iaw Table 1;
 - c. Be located prior to the Runway exit point in line with a position at least 60 m prior to the point of tangency where the code number is 3 or 4, and at least 30 m where the code number is 1 or 2; and
 - d. Have an inscription consisting of the designator of the exit taxiway and an arrow indicating the direction to follow.
22. A Runway vacated sign **should**:
 - a. Be provided where the exit taxiway is not provided with taxiway centre-line lights and there is a need to indicate to a pilot leaving a Runway the perimeter of the ILS / MLS critical / sensitive area, or the lower edge of the inner transitional surface whichever is farther from the Runway centre-line;
 - b. Be located at least on one side of the taxiway, with the distance between the sign and the centre-line of a Runway not less than the greater of the following:
 - (1) The distance between the centre-line of the Runway and the perimeter of the ILS / MLS critical / sensitive area; or
 - (2) The distance between the centre-line of the Runway and the lower edge of the inner transitional surface; and
 - c. Have an inscription depicting the Runway-holding position marking as shown in Figure 2.
23. An Intersection take-off sign **should**:
 - a. Be provided to indicate the remaining Take-Off Run Available (TORA) for such take-offs at Runways where intersection take-offs are conducted;
 - b. Be located at the left-hand side of the entry taxiway, with the distance between the sign and the centre-line of the Runway not less than 60 m where the code number is 3 or 4 and not less than 45 m where the code number is 1 or 2; and
 - c. Have an inscription consisting of a numerical message indicating the remaining TORA in metres, plus an arrow, appropriately located and oriented, indicating the direction of the take-off as shown in Figure 2.
24. A Destination sign **should**:

**Acceptable
Means of
Compliance
3516(3)**

- a. Indicate the direction to a specific destination on the Aerodrome, such as cargo area, general aviation, etc; and
- b. Have an inscription comprising an alpha, alphanumerical or numerical message identifying the destination, plus an arrow indicating the direction to proceed as shown in Figure 2.
25. A Direction sign **should**:
- a. Be provided when there is an operational need to identify the designation and direction of taxiways at an intersection; and
- b. Have an inscription comprising an alpha or alphanumerical message identifying the taxiways, plus an arrow or arrows appropriately oriented as shown in Figure 2.
26. A Location sign **should**:
- a. When combined with a direction sign, be provided when it is intended to indicate routing information prior to a taxiway intersection;
- b. Be provided at an intermediate holding position;
- c. Be provided in conjunction with a Runway designation sign except at a Runway / Runway intersection;
- d. Be provided in conjunction with a direction sign;
- e. Where necessary, be provided to identify taxiways exiting an apron or taxiways beyond an intersection;
- f. Be positioned outboard of the Runway vacated sign, where a taxiway location sign is provided in conjunction with a Runway vacated sign;
- g. Where a taxiway location sign is provided in conjunction with a Runway designation sign, be positioned outboard of the Runway designation sign;
- h. Have an inscription comprising the designation of the location of the taxiway, Runway, or other pavement the ► Aircraft ◀ is on or is entering, and **should not** contain arrows; and
- i. Where it is necessary to identify each of a series of intermediate holding positions on the same taxiway, consist of the taxiway designation and a progressive number;
27. Where used in combination with direction signs:
- a. All direction signs related to left turns **should** be placed on the left side of the location sign and all direction signs related to right turns **should** be placed on the right side of the location sign, except that where the junction consists of one intersecting taxiway, the location sign may alternatively be placed on the left-hand side;
- b. The direction signs **should** be placed such that the direction of the arrows departs increasingly from the vertical with increasing deviation of the corresponding taxiway;
- c. An appropriate direction sign **should** be placed next to the location sign where the direction of the location taxiway changes significantly beyond the intersection; and
- d. Adjacent direction signs **should** be delineated by a vertical black line as shown in Figure 2.
28. Where a taxiway ends at an intersection such as a 'T' and it is necessary to identify this, a barricade, direction sign, and / or other appropriate visual aid **should** be used, such as a yellow diagonal marker overlaid on the appropriate taxiway location sign where a taxiway ends at an intersection other than an intersection with a Runway.
29. At a taxiway intersection, information signs **should** be located prior to the intersection and in line with the taxiway intersection marking. Where there is no taxiway intersection marking, the signs **should** be installed at least 60 m from the centre-line of

**Acceptable
Means of
Compliance
3516(3)**

the intersecting taxiway where the code number is 3 or 4, and at least 40 m where the code number is 1 or 2.

30. A taxiway **should** be identified by a designator comprising a letter, letters, or a combination of a letter or letters followed by a number.

31. When designating taxiways, the use of the letters I, O, or X, and the use of words such as 'inner' and 'outer' **should** be avoided wherever possible, to avoid confusion with the numerals 1, 0, and closed marking.

32. The use of numbers alone on the manoeuvring area **should** be reserved for the designation of Runways, or to indicate the location of ► **Aircraft** ◀ stands.

**Guidance
Material
3516(3)**

Information Signs

Civil Equivalence.

33. This regulation is in line with ICAO Annex 14 Vol I para 5.4.

**Regulation
3516(4)**

Aerodrome Access Boards

3516(4) HoEs and ADH-Facing Organizations **shall** ensure that Aerodrome Access Boards are erected in prominent positions at all points where roads join the Movement Area.

**Acceptable
Means of
Compliance
3516(4)**

Aerodrome Access Boards

34. Aerodrome Access Boards **should** be of the same style as RA 3516(2).

35. Aerodrome Access Boards **should** have the following wording:

'STOP

MOVEMENT AREA

VEHICLES ARE NOT TO BE DRIVEN PAST THIS POINT WITHOUT THE
PERMISSION OF AIR TRAFFIC CONTROL'.

**Guidance
Material
3516(4)**

Aerodrome Access Boards

36. At Units where it is not possible to proceed to ATC without entering the Movement Area, this notice can be amended to show how permission could be obtained. Examples of alternative wordings are:

a. DRIVERS ARE TO REPORT TO THE GUARDROOM AND OBTAIN
PERMISSION FROM AIR TRAFFIC CONTROL BEFORE PROCEEDING; or

b. DRIVERS ARE TO REPORT TO AIR TRAFFIC CONTROL BY
TELEPHONE (EXT.....) BEFORE PROCEEDING.

37. Where, from outside the Movement Area, the authorized access to the Movement Area is through an Apron, the notice board at the entry point to the apron area needs to give due warning of the conditions for entry to the Movement Area.

38. In addition to the Movement Area boards, personnel may be given a general warning by other notice boards prominently displayed at all entrances to the Unit. These notices could read:

VEHICLES MUST GIVE WAY TO AIRCRAFT.

ALL VISITING DRIVERS ARE TO REPORT TO AIR TRAFFIC CONTROL BEFORE
PROCEEDING ON TO THE MOVEMENT AREA.

RA 3517 - Permanent Fixed Wing Aerodrome - Markers

Rationale

Aerodrome operations can often be impeded by poor visibility due to the weather or night time operations. This has the potential to be a contributory factor in hazardous incidents. Markers are used at aerodromes to provide clear and consistent information and guidance to the operating community under all conditions and particularly when markings and lights are not available or visible.

Contents

- 3517(1): General**
- 3517(2): Unpaved Runway Edge Markers**
- 3517(3): Stopway Edge Markers**
- 3517(4): Edge Markers for Snow-Covered Runways**
- 3517(5): Paved Taxiway Edge Markers**
- 3517(6): Taxiway Centre-Line Markers**
- 3517(7): Unpaved Taxiway Edge Markers**
- 3517(8): Boundary Markers**
- 3517(9): Arrestor System Markers**
- 3517(10): Distance To Go Markers**

Regulation 3517(1)

General

3517(1) Heads of Establishments (HoEs) and Aviation Duty Holder-Facing Organizations (ADH-Facing Organizations) **shall** ensure that all markers placed on an aerodrome are designed to minimize the risk of the markers damaging an Air System.

Acceptable Means of Compliance 3517(1)

General

1. Markers **should** be frangible and retro-reflective.
2. Those markers located near a runway or taxiway **should** be sufficiently low to preserve clearance for propellers, and for the engine pods of jet Air Systems. ▶◀
3. Markers **should** be securely fixed to prevent their removal by jet efflux and/or rotor down wash.

Guidance Material 3517(1)

General

Civil Equivalence.

4. This regulation is in line with International Civil Aviation Organization (ICAO) Annex 14 Vol I para 5.5.1.

Regulation 3517(2)

Unpaved Runway Edge Markers

3517(2) HoEs and ADH-Facing Organizations **shall** ensure that markers are provided when the extent of an unpaved runway is not clearly indicated by the appearance of its surface compared with that of the surrounding ground.

Acceptable Means of Compliance 3517(2)

Unpaved Runway Edge Markers

5. Where runway lights are provided, the markers **should** be incorporated in the light fixtures.
6. Where there are no lights, markers of flat rectangular or conical shape **should** be placed to delineate the runway clearly:

**Acceptable
Means of
Compliance
3517(2)**

7. Runway edge markers **should** have the following characteristics:
- The flat rectangular markers **should** have a minimum size of 1 m by 3 m and **should** be placed with their long dimension parallel to the runway centre-line.
 - The conical markers **should** have a height not exceeding 0.50 m.

**Guidance
Material
3517(2)**

Unpaved Runway Edge Markers

8. 

Civil Equivalence.

9. This regulation is in line with ICAO Annex 14 Vol I para 5.5.2.

**Regulation
3517(3)**

Stopway Edge Markers

- 3517(3) HoEs and ADH-Facing Organizations **shall** ensure that stopway edge markers are provided when the extent of a stopway is not clearly indicated by its appearance compared with that of the surrounding ground.

**Acceptable
Means of
Compliance
3517(3)**

Stopway Edge Markers

10. The stopway edge markers **should** be sufficiently different from any runway edge markers used to ensure that the two types of markers cannot be confused.

**Guidance
Material
3517(3)**

Stopway Edge Markers

Civil Equivalence.

11. This regulation is in line with ICAO Annex 14 Vol I para 5.5.3.

**Regulation
3517(4)**

Edge Markers for Snow-Covered Runways

- 3517(4) HoEs and ADH-Facing Organizations **shall** ensure that edge markers for snow-covered runways are used to indicate the usable limits of a snow-covered runway when the limits are not otherwise indicated.

**Acceptable
Means of
Compliance
3517(4)**

Edge Markers for Snow-Covered Runways

12. Edge markers for snow-covered runways **should** be placed along the sides of the runway at intervals of not more than 100 m and **should** be located symmetrically about the runway centre-line at such a distance from the centre-line that there is adequate clearance for wing tips and power plants.

13. Sufficient markers **should** be placed across the threshold and end of the runway.

**Guidance
Material
3517(4)**

Edge Markers for Snow-Covered Runways

Civil Equivalence.

14. This regulation is in line with ICAO Annex 14 Vol I para 5.5.4

**Regulation
3517(5)**

Paved Taxiway Edge Markers

- 3517(5) HoEs and ADH-Facing Organizations **shall** ensure that taxiway edge markers are provided on a taxiway where taxiway centre-line or edge lights or taxiway centre-line markers are not provided.

**Acceptable
Means of
Compliance
3517(5)**

Paved Taxiway Edge Markers

15. Taxiway edge markers **should** be installed at the same locations as the taxiway edge lights would be, had they been used.
16. Taxiway Edge markers **should**:
- Be reflective blue;
 - Have a rectangular marked surface, as viewed by the pilot, with a minimum viewing area of 150 cm²; and
 - Be frangible and a height sufficiently low to preserve clearance for propellers and for the engine pods of jet Air Systems.

**Guidance
Material
3517(5)**

Paved Taxiway Edge Markers

Civil Equivalence.

17. This regulation is in line with ICAO Annex 14 Vol I para 5.5.5.

**Regulation
3517(6)**

Taxiway Centre-Line Markers

- 3517(6) HoEs and ADH-Facing Organizations **shall** ensure that taxiway centre-line markers are provided on a taxiway where taxiway centre-line or edge lights/marking, or taxiway edge markers are not provided.

**Acceptable
Means of
Compliance
3517(6)**

Taxiway Centre-Line Markers

18. Taxiway centre-line markers **should** be installed at least at the same locations as the taxiway centre-line lights would be, had they been used.
19. Taxiway centre-line markers **should** be located on the taxiway centre-line marking except that they may be offset by not more than 0.3 m where it is not practicable to locate them on the marking.
20. Taxiway centre-line markers **should**:
- Be reflective green;
 - Have a rectangular marked surface, as viewed by the pilot, with a minimum viewing area of 20 cm²; and
 - Be designed and fitted to withstand being run over by the wheels of an Air System without damage either to the Air System or to the markers themselves.

**Guidance
Material
3517(6)**

Taxiway Centre-Line Markers

Civil Equivalence.

21. This regulation is in line with ICAO Annex 14 Vol I para 5.5.6.

**Regulation
3517(7)**

Unpaved Taxiway Edge Markers

- 3517(7) HoEs and ADH-Facing Organizations **shall** ensure that where the extent of an unpaved taxiway is not clearly indicated by its appearance compared with that of the surrounding ground, markers are provided.

**Acceptable
Means of
Compliance
3517(7)**

Unpaved Taxiway Edge Markers

22. Where taxiway lights are provided, the markers **should** be incorporated in the light fixtures.
23. Where there are no lights, suitable markers **should** be placed to clearly delineate the taxiway.

**Guidance
Material
3517(7)**

Unpaved Taxiway Edge Markers

Civil Equivalence.

24. This regulation is in line with ICAO Annex 14 Vol I para 5.5.7.

**Regulation
3517(8)**

Boundary Markers

3517(8) HoEs and ADH-Facing Organizations **shall** ensure that boundary markers are provided at an aerodrome where the landing area has no runway.

**Acceptable
Means of
Compliance
3517(8)**

Boundary Markers

25. Boundary markers **should** be spaced along the boundary of the landing area at intervals of not more than 200 m, if the type shown in Figure 1 is used, or approximately 90 m, if the conical type is used with a marker at any corner.

26. Boundary markers **should**:

- a. Be of a form similar to that shown in Figure 1, and
- b. Be coloured to contrast with the background against which they will be seen.

Figure 1. Boundary Marker Dimensions

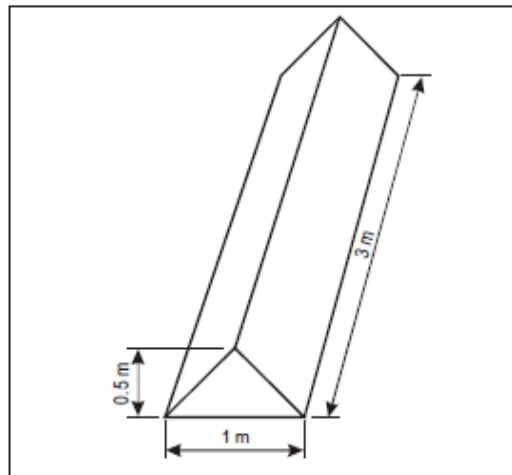

**Guidance
Material
3517(8)**

Boundary Markers

27. A single colour, orange or red, or two contrasting colours, orange and white or alternatively red and white, may be used, except where such colours merge with the background.

Civil Equivalence.

28. This regulation is in line with ICAO Annex 14 Vol I para 5.5.8.

**Regulation
3517(9)**

Arrestor System Markers

3517(9) HoEs and ADH-Facing Organizations **shall** ensure that the position of all runway arrestor gear cables are marked.

**Acceptable
Means of
Compliance
3517(9)**

Arrestor System Markers

29. The position of all runway arrestor gear cables **should** be indicated by vertical illuminated arrestor gear markers as follows:

- a. The markers **should** be placed on both sides of the runway in line with the cable and normally equidistant from the runway centre-line;

**Acceptable
Means of
Compliance
3517(9)**

- b. The distance from the edge of the usable runway to the markers **should** be a minimum 15 m but no greater than 23 m;
- c. The markers **should** show an aviation yellow disc of 1.0 m diameter on a black background;
- d. The markers **should** be frangible.

**Guidance
Material
3517(9)**

Arrestor System Markers

30. The average luminance of marker boards is detailed in RA 3515¹.

**Regulation
3517(10)**

Distance To Go Markers

- 3517(10) HoEs and ADH-Facing Organizations **shall** ensure that Runway Distance Markers (RDM) are installed on all runways.

**Acceptable
Means of
Compliance
3517(10)**

Distance To Go Markers

31. The RDM **should**
- a. Be placed on both sides of the runway on lines parallel with and normally equidistant from the centre-line of the runway.
 - b. Indicate the distance for both directions of operation.
 - c. Indicate the runway distance remaining in thousands of feet (the last three digits being omitted).
 - d. Be frangible.
32. The distance from the edge of the usable runway to the RDM **should** be a minimum 15 m but no greater than 23 m.
33. The colour of the number on each RDM **should** be white on a black background.
34. The height of the figures **should** be 1.0 m and the stroke of each figure **should** be 0.13 m wide. The breadth of the figure **should** be approximately 0.6 m.

**Guidance
Material
3517(10)**

Distance To Go Markers

35. Where the length of the runway is not an exact multiple of 300 m the amount remaining after subtraction of the maximum number of such multiples can be shared equally between and added to the runway start to the first RDM and the last RDM to the runway end distance to give the ideal position (eg a 2600 m runway will give 8 multiples of 300 m plus 200 m remaining; this shared equally gives distances of 400 m at each end of the runway).
36. Markers that would normally be at a runway or taxiway intersection may be omitted. However, they may be sited up to 30 m from the calculated position and along the line if this makes it possible to avoid omitting them altogether. The corresponding markers may remain opposite to each other.
37. The current control for an RDM will be in accordance with RA 3520(1) Table 3².
38. The average luminance of marker boards is detailed in RA 3515¹.

¹ ► Refer to ◀ RA 3515 - Permanent Fixed Wing Aerodrome - ► Lighting. ◀

² ► Refer to ◀ RA 3520(1): ► Aerodrome Electrical System Design. ◀

Intentionally Blank for Print Pagination

RA 3518 - Permanent Fixed Wing Aerodrome - Visual Aids for Denoting Obstacles

Rationale

Obstacles in and around an aerodrome, such as buildings and navigation aids, have the potential to cause damage to Air Systems. The marking and/or lighting of obstacles is intended to make them more visible to Air Systems operating at low level under visual flight conditions or moving on the ground by indicating the presence of the obstacles.

Contents

- 3518(1): Objects Within the Obstacle Limitation Surfaces
- 3518(2): Objects Outside the Obstacle Limitation Surfaces
- 3518(3): Marking of Objects - General
- 3518(4): Marking of Objects - Use of Colour
- 3518(5): Marking of Objects - Use of Markers and Flags
- 3518(6): Marking of Objects - Mobile Objects
- 3518(7): Lighting of Objects - General
- 3518(8): Lighting of Objects - Location and Number of Lights
- 3518(9): Lighting of Wind Turbines
- 3518(10): Lighting of Overhead Wires, Cables and Supporting Towers
- 3518(11): Lighting of Mobile Objects
- 3518(12): Lighting of Air System Arresting Barriers

Regulation 3518(1)

Objects Within the Obstacle Limitation Surfaces

- 3518(1) Heads of Establishments (HoEs) and Aviation Duty Holder-
▶Facing Organizations (ADH-Facing Organizations)◀ shall ensure that obstacles within the boundaries of the Obstacle Limitation Surfaces (OLS) are marked and are lit if the runway is used at night.

Acceptable Means of Compliance 3518(1)

Objects Within the Obstacle Limitation Surfaces

1. A fixed object, other than an obstacle, adjacent to a take-off climb, approach¹ or transitional surface **should** be marked and if the runway is used at night or during poor visibility, lit.
2. A fixed obstacle above a horizontal surface **should** be marked and if the aerodrome is used at night, lit. Such marking and lighting may be omitted when, for a circuit extensively obstructed by immovable objects or terrain, procedures have been established to ensure safe vertical clearance below prescribed flight paths.
3. A fixed object that extends above an obstacle limitation surface **should** be marked and, if the runway is used at night, lit.
4. Any elevated Aerodrome Ground Lighting (AGL) within the movement area which is not in itself sufficiently conspicuous **should** be marked to be conspicuous by day. Obstacle lights **should not** be installed on elevated ground lights or signs in the movement area.
5. All obstacles within the distance specified in RA 3511▶²◀, from the centre-line of a taxiway, an apron taxiway, or Air System stand taxi lane **should** be marked and if the taxiway, apron taxiway or Air System stand taxi lane is used at night, lit.

¹ Within 3000 m of the inner edge of the approach surface.

² ▶Refer to RA 3511 – Permanent Fixed Wing Aerodrome: Physical Characteristics, Table 5, column 11 or 12.◀

**Acceptable
Means of
Compliance
3518(1)**

6. Overhead wires, cables, etc, crossing a river, waterway, valley or highway **should** be marked and their supporting towers marked and lit if they are identified as infringing OLS or otherwise if an aeronautical study indicates that the wires or cables could constitute a hazard to Air Systems.

**Guidance
Material
3518(1)**

Objects Within the Obstacle Limitation Surfaces

7. Marking or lighting may be omitted when:
- The obstacle is shielded by another fixed obstacle;
 - The obstacle is lit by medium-intensity obstacle lights, by day, and its height above the level of the surrounding ground does not exceed 150 m;
 - The obstacle is lit by high-intensity obstacle lights by day; and
 - The obstacle is a lighthouse and a safety assessment indicates the lighthouse light to be sufficient.
8. Marking of elevated AGL can be achieved by marking their position with Airfield Retro-reflective Markers (ARMs) and/or utilizing AGL painted aviation yellow.
9. Any road or railway within the approach will be 4.8 m below the approach clearance plane. Where the required clearance cannot be achieved, or when the road or railway passes through the clearway, measures ►need to◄ be taken within the UK to control the road traffic, or, as will invariably be the case with railways, to withdraw the end of the runway so that the necessary clearance is obtained. In addition, at aerodromes operating jet Air Systems which are liable to engine failure from bird strike, the need for control of traffic on any road up to 460 m (1500 ft) from runway end will be considered. Applications for the control of road traffic must be submitted to the Defence Infrastructure Organisation (DIO)/relevant Front Line Command (FLC) for consideration and decisions to withdraw ends of runways must be confirmed, by the appropriate FLC or equivalent. Overseas, normal peacetime procedures for liaison with the host nation ►need to◄ be followed.

Civil Equivalence.

10. This regulation is in line with International Civil Aviation Organization (ICAO) Annex 14 Vol I Section 6.1.1.2 – 6.1.1.10.

**Regulation
3518(2)**

Objects Outside the Obstacle Limitation Surfaces

3518(2) HoEs and ADH-Facing Organizations **shall** ensure that objects outside the boundaries of the OLS that are considered a hazard to aviation are marked and/or lit.

**Acceptable
Means of
Compliance
3518(2)**

Objects Outside the Obstacle Limitation Surfaces

11. Objects outside of the OLS which extend to a height of 150 m or more, that are considered a hazard to aviation, **should** be marked and lit, except that the marking may be omitted when the obstacle is lit by high-intensity obstacle lights by day.
12. Other objects outside the OLS **should** be marked and/or lit if an aeronautical study indicates that the object could constitute a hazard to Air Systems.

**Guidance
Material
3518(2)**

Objects Outside the Obstacle Limitation Surfaces

Civil Equivalence.

13. This regulation is in line with ICAO Annex 14 Vol I para 6.1.2.

**Regulation
3518(3)**

Marking of Objects - General

3518(3) HoEs and ADH-Facing Organizations **shall** ensure that all fixed objects that require marking are conspicuously marked.

**Acceptable
Means of
Compliance
3518(3)**

Marking of Objects - General

14. All fixed objects that are marked **should** whenever practicable, be coloured.

**Guidance
Material
3518(3)**

Marking of Objects - General

15. Where painting certain precision or critical surfaces would have an adverse effect on the desired transmission or radiation characteristics of a radio frequency signal, such painting may be omitted.

**Regulation
3518(4)**

Marking of Objects - Use of Colour

3518(4) HoEs and ADH-Facing Organizations **shall** ensure that colours and patterns used to mark objects contrast with each other and the background against which they will be seen. The chromaticity and luminance factors of objects **shall** be chosen so that the possibility of confusion of colours is minimized.

**Acceptable
Means of
Compliance
3518(4)**

Marking of Objects - Use of Colour

16. An object **should** be coloured to show a chequered pattern if it has essentially unbroken surfaces, and its projection on any vertical plane equals or exceeds 4.5 m in both dimensions. The pattern **should** consist of rectangles of not less than 1.5 m and not more than 3 m on a side, the corners being of the darker colour.
17. An object **should** be coloured to show alternating contrasting bands if:
- It has essentially unbroken surfaces, and has one dimension, horizontal or vertical, greater than 1.5 m, and the other dimension, horizontal or vertical, less than 4.5 m; or
 - It has broken surfaces with either a vertical or a horizontal dimension greater than 1.5 m.
18. The bands **should** be perpendicular to the longest dimension and have a width approximately 1/7 of the longest dimension or 30 m, whichever is less. The bands on the extremities of the object **should** be of the darker colour (see Figures 1 and 2). The dimensions of the marking band widths **should** be in accordance with (iaw) Table 1.

Figure 1. Band Dimensions

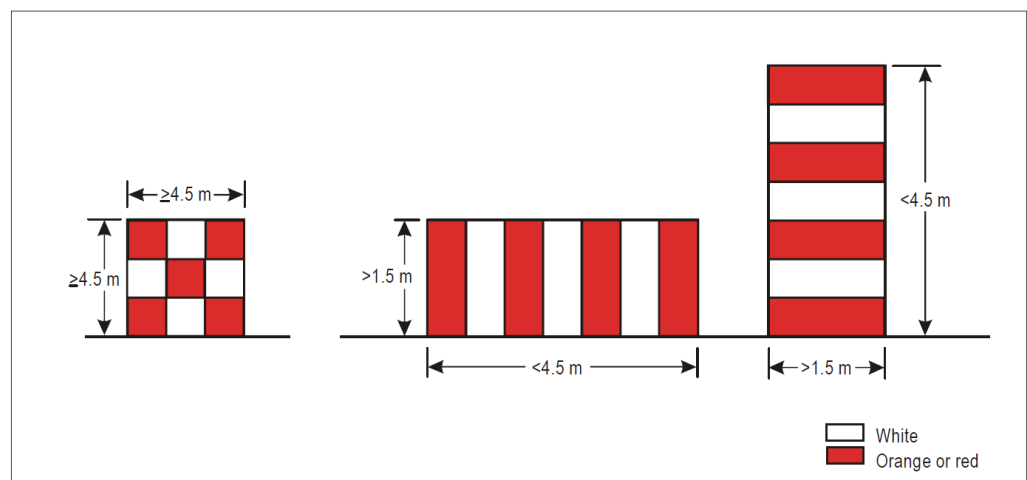

Acceptable Means of Compliance 3518(4)

Figure 2. Band Location

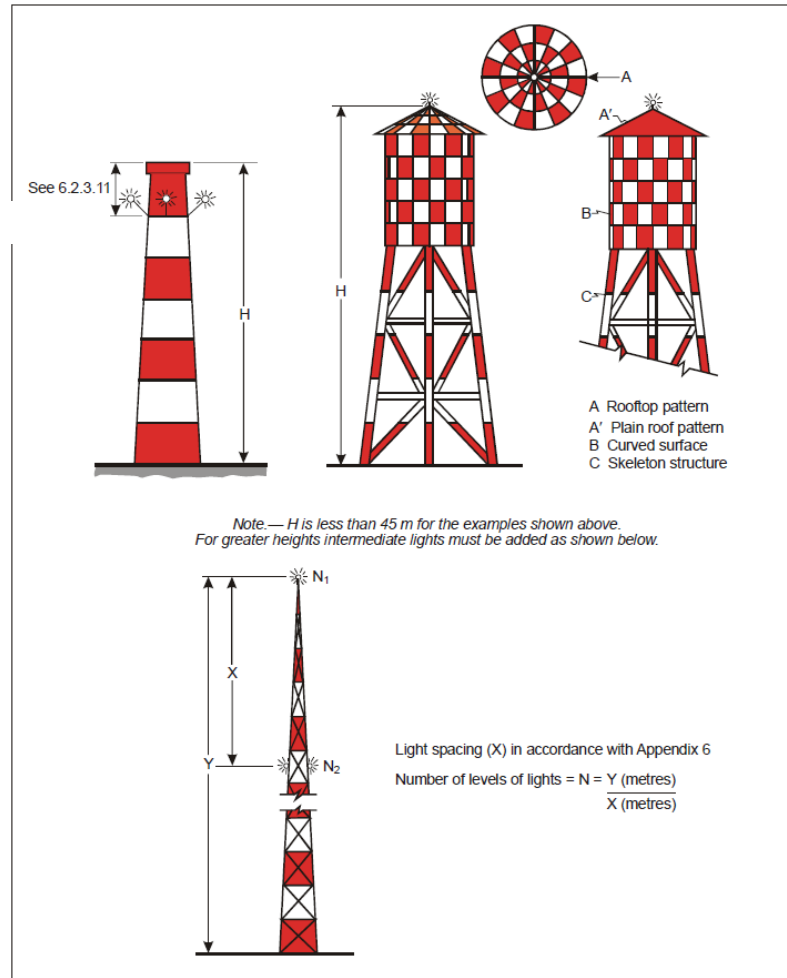

Table 1. Marking band widths

| Longest dimension | | Band width |
|-------------------|---------------|---------------------------|
| Greater than | Not exceeding | |
| 1.5 m | 210 m | 1/7 of longest dimension |
| 210 m | 270 m | 1/9 of longest dimension |
| 270 m | 330 m | 1/11 of longest dimension |
| 330 m | 390 m | 1/13 of longest dimension |
| 390 m | 450 m | 1/15 of longest dimension |
| 450 m | 510 m | 1/17 of longest dimension |
| 510 m | 570 m | 1/19 of longest dimension |
| 570 m | 630 m | 1/21 of longest dimension |

19. An object **should** be coloured in a single conspicuous colour if its projection on any vertical plane has both dimensions less than 1.5 m.
20. Red and white or alternatively orange and white **should** be used.
21. Where a wind turbine is deemed to be an obstacle, the rotor blades, nacelle and upper 2/3 of the supporting mast of wind turbines **should** be painted white, unless otherwise indicated by an aeronautical study.
22. Colour and discrimination requirements for all objects **should** be as detailed in ICAO Annex 14, Vol I, Appendix 1.

**Guidance
Material
3518(4)**

Marking of Objects - Use of Colour

Civil Equivalence.

23. This regulation is in line with ICAO Annex 14 Vol I para 6.2.

**Regulation
3518(5)**

Marking of Objects - Use of Markers and Flags

- 3518(5) HoEs and ADH-Facing Organizations **shall** ensure that markers and flags on objects are readily identifiable both from the ground and air, located in conspicuous positions and not increase the hazard the object presents.

**Acceptable
Means of
Compliance
3518(5)**

Marking of Objects - Use of Markers and Flags

24. Markers displayed on or adjacent to objects **should**:
- Be located in conspicuous positions so as to retain the general definition of the object;
 - Be recognisable in clear weather from a distance of at least 1000 m for an object to be viewed from the air and 300 m for an object to be viewed from the ground in all directions in which an Air System is likely to approach the object;
 - Have a distinctive shape to the extent necessary to ensure that they are not mistaken for markers employed to convey other information; and
 - Be of one colour. When installed, white and red, or white and orange markers **should** be displayed alternately.
25. Markers displayed on an overhead wire, cable, etc, **should**:
- Be spherical and have a diameter of not less than 60 cm.
 - Have a spacing between two consecutive markers, or between a marker and a supporting tower be appropriate to the diameter of the marker. The spacing **should** be less than 30 m where the marker diameter is 60 cm, increasing progressively with increase of the marker diameter to:
 - 35 m where the marker diameter is 80 cm; and
 - Further progressive increases to a maximum of 40 m where the marker diameter is of at least 130 cm.
 - Where multiple wires, cables, etc, are involved, be located not lower than the level of the highest wire at the point marked; and
 - Each marker **should** be one colour. When installed, white and red, or white and orange markers **should** be displayed alternately.
26. When it has been determined that an overhead wire, cable, etc, needs to be marked but it is not practicable to install markers on the wire, cable, etc, then high intensity obstacle lights, Type B, **should** be provided on their supporting towers.
27. Flags displayed on or adjacent to objects **should**:
- Be placed on top of, or around the highest edge of the object;
 - When used to mark extensive objects or groups of closely spaced objects, be displayed at least every 15 m;
 - When used to mark fixed objects, be at least 0.6 m square; and
 - Be a singular conspicuous colour, or a combination of two triangular sections.

**Guidance
Material
3518(5)**

Marking of Objects - Use of Markers and Flags

Civil Equivalence.

28. This regulation is in line with ICAO Annex 14 Vol I para 6.2.

**Regulation
3518(6)**

Marking of Objects - Mobile Objects

3518(6) HoEs and ADH-Facing Organizations **shall** ensure that all mobile objects to be marked are coloured or display flags.

**Acceptable
Means of
Compliance
3518(6)**

Marking of Objects - Mobile Objects

29. When mobile objects are marked by colour, a single conspicuous colour, preferably red or yellowish green for emergency vehicles and yellow for service vehicles, **should** be used.

30. Flags used to mark mobile objects **should** be displayed around, or on top of, the highest edge of the object.

31. Flags used to mark mobile objects **should not** be less than 0.9 m on each side and **should** consist of a chequered pattern, each square having sides of not less than 0.3 m. The colours of the pattern **should** contrast each with the other and with the background against which they will be seen. Orange and white or alternatively red and white **should** be used, except where such colours merge with the background.

**Guidance
Material
3518(6)**

Marking of Objects - Mobile Objects

Civil Equivalence.

32. This regulation is in line with ICAO Annex 14 Vol I para 6.2.

**Regulation
3518(7)**

Lighting of Objects - General

3518(7) HoEs and ADH-Facing Organizations **shall** ensure that the objects which ►are to◀ be lit are indicated by low, medium or high intensity obstacle lights, or a combination of such lights.

**Acceptable
Means of
Compliance
3518(7)**

Lighting of Objects - General

33. Low intensity obstacle lights, Types A, B, C and D, medium intensity obstacle lights, Types A, B and C, high intensity obstacle lights Type A and B, **should** have operating characteristics iaw the specifications in Table 2 and RA 3515³.

34. One or more low, medium or high intensity obstacle lights **should** be located as close as practicable to the top of the object.

35. In the case of chimney tower, the top lights **should** be placed sufficiently below the top of the structure to minimize contamination by smoke, etc. (see Figure 2).

36. A tower or antenna structure greater than 12 m in height indicated by high intensity obstacle lights by day and with an appurtenance, such as a rod or an antenna, **should** where it is not practicable to locate a high intensity obstacle light on the top of the appurtenance, have such a light located at the highest practicable point, and if possible, a medium-intensity obstacle light, Type A, mounted on the top.

37. An extensive object or of a group of closely spaced objects that are required to be lit **should**:

a. If penetrating a horizontal OLS or located outside an OLS, have top lights arranged so as to at least indicate the points or edges of the object highest in relation to the OLS or above the ground, and so as to indicate the general definition and the extent of the objects; or

b. If penetrating a sloping OLS, have top lights arranged so as to at least indicate the points or edges of the object highest in relation to the OLS, and so

³ RA 3515 - Permanent Fixed Wing Aerodrome - ►lighting.◀

**Acceptable
Means of
Compliance
3518(7)**

as to indicate the general definition and the extent of the objects. If two or more edges are of the same height, the edge nearest the landing area **should** be marked.

38. Where lights are applied to display the general definition of an extensive object or a group of closely spaced objects, they **should**:

a. Where low intensity lights are used, be spaced at longitudinal intervals not exceeding 45 m; and

b. Where medium intensity lights are used, be spaced at longitudinal intervals not exceeding 900 m.

39. High intensity obstacle lights, Type A, and medium intensity obstacle lights, Types A and B, located on an object **should** flash simultaneously.

40. The number and arrangement of the obstacle lights at each level **should** be marked so that the object is indicated from every angle in azimuth. Where a light is shielded in any direction by another part of the object, or by an adjacent object, additional lights **should** be provided on that object in such a way as to retain the general definition of the object to be lighted. If the shielded light does not contribute to the definition of the object to be lighted, it may be omitted.

41. All fixed obstacle lighting located on the aerodrome **should** be under the control of Air Traffic Control.

Table 2. Characteristics of Obstacle Lights

| 1 | 2 | 3 | 4 | 5 | 6 |
|---|-------------|-----------------------|---|------------------------------|---------------------------|
| Light Type | Colour | Signal type/ (fpm) | Peak intensity (cd) at given Background Luminance | | |
| | | | Day | Twilight | Night |
| | | | (> 500 cd/m ²) | (50- 500 cd/m ²) | (< 50 cd/m ²) |
| Low-intensity, Type A (fixed obstacle) | Red | Fixed | N/A | N/A | 10 |
| Low-intensity, Type B (fixed obstacle) | Red | Fixed | N/A | N/A | 32 |
| Low-intensity, Type C (mobile obstacle) | Yellow/Blue | Flashing (60-90) | N/A | 40 | 40 |
| Low-intensity, Type D (follow-me vehicle) | Yellow | Flashing (60-90) | N/A | 200 | 200 |
| Medium-intensity, Type A | White | Flashing (20-60) | 20 000 | 20 000 | 2 000 |
| Medium-intensity, Type B | Red | Flashing (20-60) | N/A | N/A | 2 000 |
| Medium-intensity, Type C | Red | Fixed | N/A | N/A | 2 000 |
| High-intensity, Type A | White | Flashing (40-60) | 200 000 | 20 000 | 2 000 |
| High-intensity, Type B | White | Flashing (40-60) | 100 000 | 20 000 | 2 000 |

**Guidance
Material
3518(7)**

Lighting of Objects - General

42. Guidance on how a combination of low, medium and/or high-intensity lights on obstacles ► that need to ◀ be displayed are given in ICAO Annex 14, Volume 1, Appendix 6.

43. When the OLS concerned is sloping and the highest point above the OLS is not the highest point of the object, additional obstacle lights may be placed on the highest point of the object.

44. High-intensity obstacle lights are intended for day use as well as night use. Care is needed to ensure that these lights do not create disconcerting dazzle to Aircrew in flight.

45. When, subject to a Safety Assessment, it has been shown that the use of high intensity obstacle lights, Type A, or medium intensity obstacle lights, Type A, at night may dazzle pilots in the vicinity of an aerodrome (within approximately 10 km radius) or cause significant environmental concerns, a dual obstacle lighting system may be provided. This system may be composed of high intensity obstacle lights, Type A, or medium-intensity obstacle lights, Type A, as appropriate, for daytime and twilight use and medium intensity obstacle lights, Type B or C, for night-time use.

Civil Equivalence.

46. This regulation is in line with ICAO Annex 14 Vol I para 6.2.

**Regulation
3518(8)**

Lighting of Objects - Location and Number of Lights

3518(8) HoEs and ADH-Facing Organizations **shall** ensure that the number and arrangement of low, medium or high intensity obstacle lights at each level to be marked are such that the object is indicated from every angle in azimuth.

**Acceptable
Means of
Compliance
3518(8)**

Lighting of Objects - Location and Number of Lights

47. ►◀ For objects with a height less than 45 m above ground level, obstacle lights **should** be used as follows:

- a. Low intensity obstacle lights, Type A or B;
- b. Where the use of low intensity obstacle lights, Type A or B, would be inadequate⁴ or an early special warning is required, then medium or high intensity obstacle lights **should** be used;
- c. Low intensity obstacle lights, Type B, **should** be used either alone or in combination with medium intensity obstacle lights, Type B, iaw sub-para d. below; and
- d. Medium intensity obstacle lights, Type A, B or C, **should** be used where the object is an extensive one. Medium intensity obstacle lights, Types A and C, **should** be used alone, whereas medium intensity obstacle lights, Type B, **should** be used either alone or in combination with low intensity obstacle lights, Type B.

48. ►◀ For objects with a height 45 m to a height less than 150 m above ground level, obstacle lights **should** be used as follows:

- a. Medium intensity obstacle lights, Type A, B or C, **should** be used. Medium intensity obstacle lights, Types A and C, **should** be used alone, whereas medium intensity obstacle lights, Type B, **should** be used either alone or in combination with low intensity obstacle lights, Type B.
- b. Where an object is indicated by medium intensity obstacle lights, Type A, and the top of the object is more than 105 m above the level of the surrounding ground or the elevation of tops of nearby buildings (when the object to be marked is surrounded by buildings), additional lights **should** be provided at intermediate levels. These additional intermediate lights **should** be spaced as

⁴ Such as areas away from the movement area or in areas on the movement area with high levels of background luminance.

**Acceptable
Means of
Compliance
3518(8)**

equally as practicable, between the top lights and ground level or the level of tops of nearby buildings, as appropriate, with the spacing not exceeding 105 m.

c. Where an object is indicated by medium intensity obstacle lights, Type B, and the top of the object is more than 45 m above the level of the surrounding ground or the elevation of tops of nearby buildings (when the object to be marked is surrounded by buildings), additional lights **should** be provided at intermediate levels. These additional intermediate lights **should** be alternately low intensity obstacle lights, Type B, and medium intensity obstacle lights, Type B, and **should** be spaced as equally as practicable between the top lights and ground level or the level of tops of nearby buildings, as appropriate, with the spacing not exceeding 52 m.

d. Where an object is indicated by medium intensity obstacle lights, Type C, and the top of the object is more than 45 m above the level of the surrounding ground or the elevation of tops of nearby buildings (when the object to be marked is surrounded by buildings), additional lights **should** be provided at intermediate levels. These additional intermediate lights **should** be spaced as equally as practicable, between the top lights and ground level or the level of tops of nearby buildings, as appropriate, with the spacing not exceeding 52 m.

e. Where high intensity obstacle lights, Type A, are used, they **should** be spaced at uniform intervals not exceeding 105 m between the ground level and the top lights, except that where an object to be marked is surrounded by buildings, the elevation of the tops of the buildings **should** be used as the equivalent of the ground level when determining the number of light levels.

49. ►◄ For objects with a height 150 m or more above ground level, obstacle lights **should** be used as follows:

a. High-intensity obstacle lights, Type A, **should** be used to indicate the presence of an object if its height above the level of the surrounding ground exceeds 150 m.

b. Where high-intensity obstacle lights, Type A, are used, they **should** be spaced at uniform intervals not exceeding 105 m between the ground level and the top light(s).

c. Where use of high-intensity obstacle lights, Type A, at night may dazzle pilots in the vicinity of an aerodrome (within approximately 10 000 m radius) or cause significant environmental concerns, medium-intensity obstacle lights, Type C, **should** be used alone, whereas medium intensity obstacle lights, Type B, **should** be used either alone or in combination with low-intensity obstacle lights, Type B.

**Guidance
Material
3518(8)**

Lighting of Objects - Location and Number of Lights

50. A group of buildings is regarded as an extensive object.

51. When, subject to a Safety Assessment, it has been shown that the use of high intensity obstacle lights, Type A, at night may dazzle pilots near an aerodrome (within approximately 10 km radius) or cause significant environmental concerns, medium intensity obstacle lights, Type C, may be used alone, whereas medium intensity obstacle lights, Type B, may be used either alone or in combination with low intensity obstacle lights, Type B.

Civil Equivalence.

52. This regulation is in line with ICAO Annex 14 Vol I para 6.2.

**Regulation
3518(9)**

Lighting of Wind Turbines

3518(9) HoE and ADH-Facing Organizations **shall** ensure that a wind turbine is marked and, if necessary, lit if it is determined to be an obstacle.

**Acceptable
Means of
Compliance
3518(9)**

Lighting of Wind Turbines

53. Medium intensity obstacle lights **should** be used to light Wind Turbines.
54. Where a wind farm is a group of two or more wind turbines, it **should** be regarded as an extensive object and the lights **should** be installed:
- To identify the perimeter of the wind farm;
 - Respecting the maximum spacing, iaw RA 3518(8), between the lights along the perimeter, unless a dedicated assessment shows that a greater spacing can be used;
 - So that, where flashing lights are used, they flash simultaneously; and
 - So that, within a wind farm, any wind turbines of significantly higher elevation are also identified wherever they are located.
55. The obstacle lights **should** be installed on the nacelle in such a manner as to provide an unobstructed view for Air Systems approaching from any direction.

**Guidance
Material
3518(9)**

Lighting of Wind Turbines

Civil Equivalence.

56. This regulation is in line with ICAO Annex 14 Vol I para 6.2.

**Regulation
3518(10)**

Lighting of Overhead Wires, Cables and Supporting Towers

3518(10) HoE and ADH Facing ► **organizations** ◀ **shall** ensure that Overhead Wires, Cables and Supporting Towers are marked/lit.

**Acceptable
Means of
Compliance
3518(10)**

Lighting of Overhead Wires, Cables and Supporting Towers

57. High intensity obstacle lights, Type B, **should** be used to indicate the presence of a tower supporting overhead wires, cables, etc, where:
- An aeronautical study indicates such lights to be essential for the recognition of the presence of wires, cables, etc; or
 - It has not been found practicable to install markers on the wires, cables, etc.
58. Where high intensity obstacle lights, Type B, are used, they **should** be located at three levels:
- At the top of the tower;
 - At the lowest level of the catenary of the wires or cables; and
 - At approximately midway between these two levels.
59. The installation setting angles for high intensity obstacle lights, Type B, **should** be iaw Table 3.

Table 3. Installation setting angles for high-intensity obstacle lights

| Height of light unit above terrain | Angle of the peak of the beam above the horizontal |
|------------------------------------|--|
| Greater than 151 m AGL | 0° |
| 122 m to 151 m AGL | 1° |
| 92 m to 122 m AGL | 2° |
| Less than 92 m AGL | 3° |

**Guidance
Material
3518(10)**

Lighting of Overhead Wires, Cables and Supporting Towers

60. High intensity obstacle lights, Type B, indicating the presence of a tower supporting overhead wires, cables, etc, may flash sequentially; first the middle light, second the top light and last, the bottom light.
61. The intervals between flashes of the lights may approximate the following ratios:
- Middle and top light - 1/13 cycle time;
 - Top and bottom light - 2/13 cycle time; and
 - Bottom and middle light - 10/13 cycle time.
62. In some cases, this may require locating the lights off the tower.
63. When a Safety Assessment has determined that the use of high intensity obstacle lights, Type A, at night may dazzle pilots in the vicinity of an aerodrome (within approximately 10 km radius) or cause significant environmental concerns, medium intensity obstacle lights, Type C, may be used alone. Whereas medium intensity obstacle lights, Type B, may be used either alone or in combination with low intensity obstacle lights, Type B.

Civil Equivalence.

64. This regulation is in line with ICAO Annex 14 Vol I para 6.2.

**Regulation
3518(11)**

Lighting of Mobile Objects

- 3518(11) HoEs and ADH-Facing Organizations **shall** ensure that mobile objects which use the aerodrome, such as cranes or vehicles, are lit if the aerodrome is used at night or in poor visibility.

**Acceptable
Means of
Compliance
3518(11)**

Lighting of Mobile Objects

65. Low intensity obstacle lights, Type C, **should** be displayed on vehicles and other mobile objects excluding Air Systems.
66. Low intensity obstacle lights, Type C, displayed on vehicles associated with emergency or security **should** be flashing-blue and those displayed on other vehicles **should** be flashing-yellow.
67. Low intensity obstacle lights, Type D, **should** be displayed on follow-me vehicles.
68. Low intensity obstacle lights on objects with limited mobility such as aerobridges **should** be fixed-red, and as a minimum be in accordance with the specifications for low-intensity obstacle lights, Type A, in Table 2. The intensity of the lights **should** be sufficient to ensure conspicuity considering the intensity of the adjacent lights and the general levels of illumination against which they would normally be viewed.

**Guidance
Material
3518(11)**

Lighting of Mobile Objects

Civil Equivalence.

69. This regulation is in line with ICAO Annex 14 Vol I para 6.2.

**Regulation
3518(12)**

Lighting of Air System Arresting Barriers

- 3518(12) HoEs and ADH-Facing Organizations **shall** ensure that arrestor barriers of the elevated type are considered as obstacles. In addition to obstacle lights, warning lights **shall** project into the approach sector.

**Acceptable
Means of
Compliance
3518(12)****Lighting of Air System Arresting Barriers**

70. A flashing red uni-directional light located adjacent to each barrier mechanism and directed into the overshoot area **should** be provided.

71. The warning lights **should**:

- a. Be actuated by the raising mechanism to operate automatically when the barrier is raised;
- b. Flash simultaneously and continuously at a flash rate of 60 flashes per minute until the barrier is lowered;
- c. Be mounted on a frangible structure at a height of 0.9 m above ground level and located just outside the brake mechanism assembly; and
- d. Have physical characteristics similar to those of stopway lights iaw RA 3515(15)⁵.

**Guidance
Material
3518(12)****Lighting of Air System Arresting Barriers**

72. It is recommended that physical checks of the barrier and the warning light system be made twice daily and after each change of direction of traffic.

⁵ ▶ Refer to ◀ RA 3515(15): ▶ ◀ Runway Lights – Stopway Lights.

RA 3519 - Permanent Fixed Wing Aerodrome - Visual Aids for Denoting Restricted Use Areas

Rationale

Some areas of the aerodrome will be unsafe for Air Systems to use. These areas need to be clearly identifiable, in order to minimise the probability of damage to an Air System. Standardised marking of these areas is required to inform operators of their presence and potential for causing damage.

Contents

3519(1): Closed Runways and Taxiways

3519(2): Hazardous Areas

3519(3): Unserviceable Areas

Regulation

3519(1)

Closed Runways and Taxiways

3519(1) Heads of Establishments (HoEs) and Aviation Duty Holder (ADH) Facing organizations **shall** ensure that a closed marking is displayed on a runway, or taxiway, or portion thereof, which is permanently or temporarily closed to the use of all Air Systems.

Acceptable Means of Compliance 3519(1)

Closed Runways and Taxiways

1. A closed marking **should** be displayed on a temporarily closed runway or taxiway, except that such marking may be omitted when the closing is of short duration (as approved by the Aerodrome Operator) and adequate warning is provided to users.
2. Closed Runway markings **should** be:
 - a. White and be of the form and proportions as detailed in Figure 1; and
 - b. Placed at each end of the runway, or portion thereof, declared closed, and additional markings **should** be so placed that the maximum interval between markings does not exceed 300m.
3. Closed Taxiway markings **should** be:
 - a. Yellow and be of the form and proportions as detailed in Figure 1; and
 - b. Placed at least at each end of the taxiway or portion thereof closed.

Figure 1. Closed Runway Marking

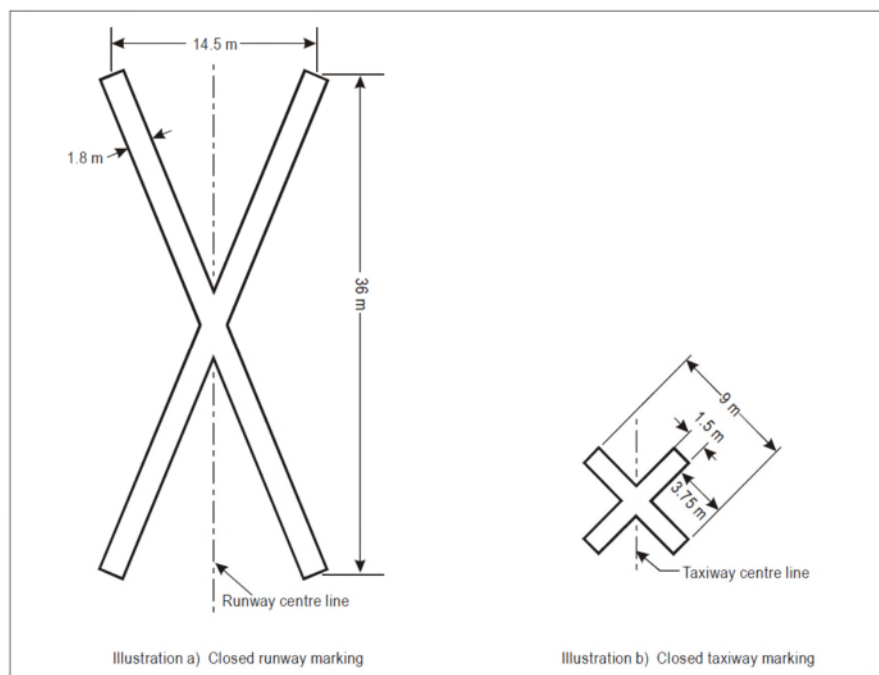

Acceptable Means of Compliance 3519(1)

4. When a runway, or taxiway, or portion thereof is permanently or temporarily closed, all normal runway and taxiway markings **should** be permanently removed.
5. In addition to closed markings, when the runway, or taxiway, or portion thereof closed is intercepted by a usable runway or taxiway which is used at night, unserviceability lights **should** be placed across the entrance to the closed area at intervals not exceeding 3m.
6. Lighting on a closed runway or taxiway or portion thereof **should not** be operated, except as required for maintenance purposes.

Guidance Material 3519(1)

Closed Runways and Taxiways

7. Where a closed runway is available for emergency use and providing it has been inspected in the previous six months and declared serviceable for an emergency landing at any time, an underscored closed marking may be placed at each end of the runway, or portion thereof, declared closed, and additional underscored markings may be so placed that the maximum interval between markings does not exceed 300m (Figure 2).

Figure 2. Emergency Use Closed Runway Marking

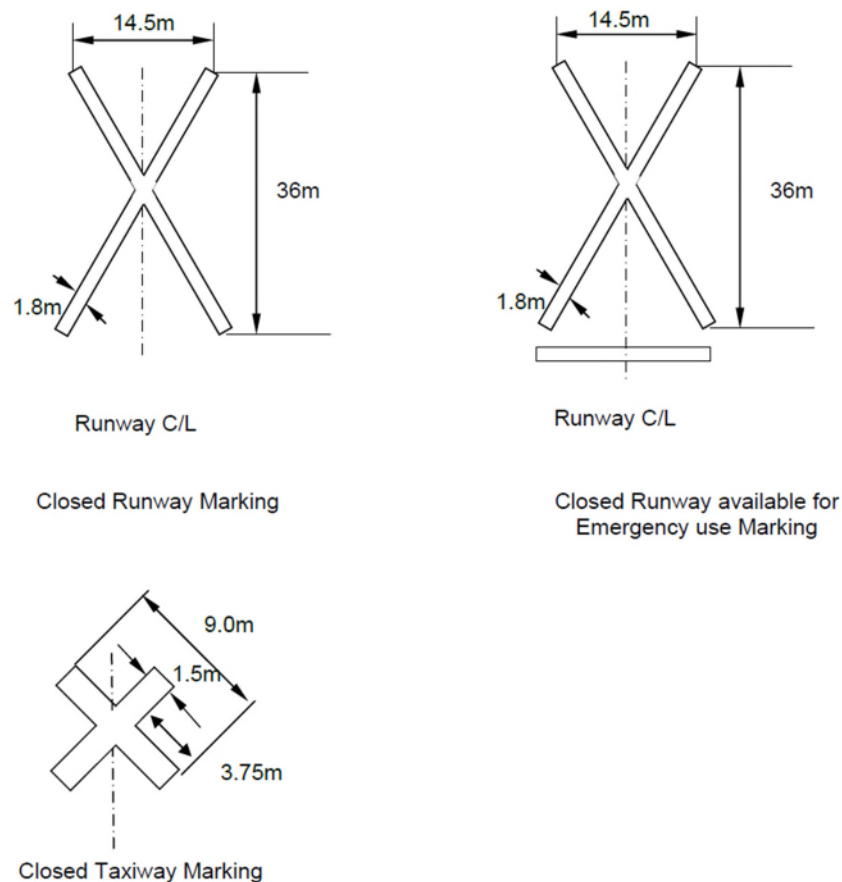

Civil Equivalence.

8. This regulation is in line with International Civil Aviation Organization (ICAO) Annex 14 Vol I para 7.1.

Regulation 3519(2)

Hazardous Areas

- 3519(2) HoEs and ADH Facing organizations **shall** ensure that, if the provision of runway side stripes and taxiway edge markings do not provide adequate definition of the operational surface, restricted use area markings are applied to the non-operational area. Restricted use and hazardous areas on or adjacent to the runway and taxiway surfaces **shall** be marked for better recognition.

**Acceptable
Means of
Compliance
3519(2)**

Hazardous Areas

9. **Runway Shoulder.** Runway Shoulder restricted use area markings **should**:
- Be a series of yellow (non-reflective aviation surface yellow) stripes;
 - Be 0.9m wide extending outboard at an angle of 45° from the edge of the operational surface for not less than 1.5m measured perpendicular to the runway edge to within 1.5m of the outer edge of the shoulder, or for a distance of 7.5m whichever is less (Figure 3);
 - Be no more than 30m apart; and
 - Lie on a line forming a chevron with the apex on the runway centre-line and pointing toward the midpoint of the runway.
10. **Taxiway Shoulder.** Taxiway Shoulder restricted use area markings **should**:
- Be a series of yellow (non-reflective aviation surface yellow) stripes which:
 - Be perpendicular to and extend outward from the taxiway edge for not less than 1.5m (Figure 3); and
 - Be no less than 0.9m wide and spaced not more than 30m apart, and on curved edges not more than 15m apart.
11. **Restricted Use Area.** Restricted Use Area markings at Pre-Threshold areas **should** be marked with a chevron marking if:
- The surface before a threshold is paved;
 - Exceeds 60m in length; and
 - Is not suitable for normal use by Air Systems.
12. Restricted Use Area markings **should**:
- Point in the direction of the runway and be placed as shown in Figure 3; and
 - Be aviation yellow with an overall width of 0.9m.
13. Blast pavement striping **should** be at least 15m long or the width of the blast pavement if less than 15m.

Figure 3. Hazardous Area Markings

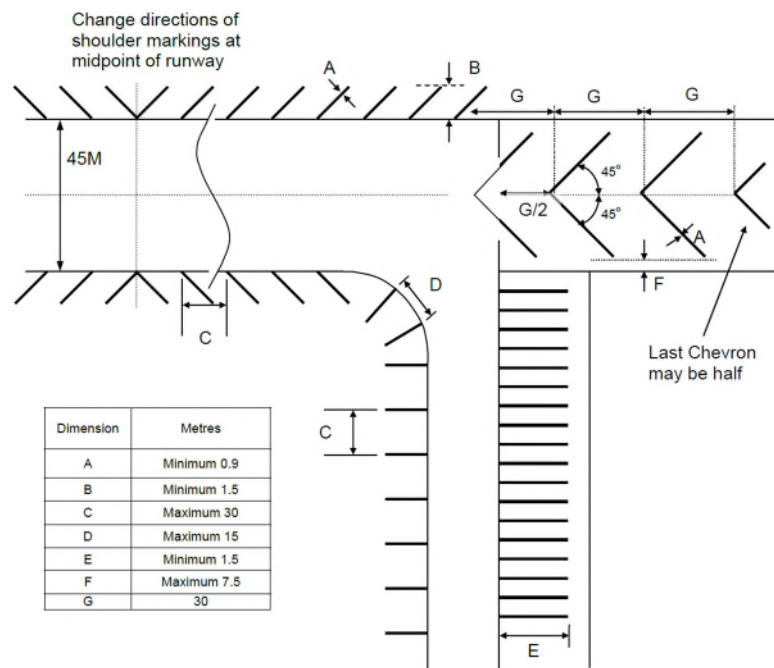

**Guidance
Material
3519(2)**

Hazardous Areas

Civil Equivalence.

14. This regulation is in line with ICAO Annex 14 Vol I para 7.2.

**Regulation
3519(3)**

Unserviceable Areas

3519(3) HoEs and ADH Facing organizations **shall** ensure that unserviceability markers are displayed wherever any portion of a taxiway, apron or holding bay is unfit for the movement of Air Systems but it is still possible for an Air System to bypass the area safely. On a movement area used at night, unserviceability lights **shall** be used.

**Acceptable
Means of
Compliance
3519(3)**

Unserviceable Areas

15. Unserviceability markers, and where necessary lights, **should** be placed at intervals sufficiently close to delineate the unserviceable area.

16. Unserviceability markers **should** consist of conspicuous upstanding devices such as flags, cones, lights or marker boards with the following properties:

- a. An unserviceability cone **should** be at least 0.5m in height and red, orange, or yellow, or any one of these colours in combination with white;
- b. An unserviceability flag **should** be at least 0.5m square and red, orange, or yellow, or any one of these colours in combination with white; and
- c. An unserviceability marker board **should** be at least 0.5m in height and 0.9m in length, with alternate red and white, or orange and white vertical stripes.
- d. An unserviceability light **should** consist of a red fixed light. The light **should** have an intensity sufficient to ensure conspicuity considering the intensity of the adjacent lights and the general level of illumination against which it would normally be viewed. In no case is the intensity to be less than 10cds of red light.

**Guidance
Material
3519(3)**

Unserviceable Areas

Civil Equivalence.

17. This regulation is in line with ICAO Annex 14 Vol I para 7.4.

RA 3520 - Permanent Fixed Wing Aerodrome - Aerodrome Electrical Systems

Rationale

The safety of operations at aerodromes is dependent on the quality of the power supplied through safety-related electrical systems. In order to protect the electrical power supply the system may include connections to one or more external sources of electric power supply, one or more local generating facilities and to a distribution network including transformers and switchgear.

Contents

3520(1): Aerodrome Electrical System Design

3520(2): Interleaving Aerodrome Ground Lighting

3520(3): Truck Runway Control Electrical Services

Regulation

3520(1)

Aerodrome Electrical System Design

3520(1) Heads of Establishments (HoEs) and Aviation Duty Holder (ADH) Facing organizations **shall** ensure that the design and provision of electrical power systems for aerodrome visual and radio navigation aids is such that normal and non-normal operation does not result in inadequate visual and non-visual guidance or misleading information.

Acceptable Means of Compliance

3520(1)

Aerodrome Electrical System Design

1. Adequate primary electrical power supply **should** be available at aerodromes for the safe functioning of air navigation facilities.
2. Secondary power supplies **should** be provided for the following:
 - a. Precision and Non-Precision approach runways;
 - b. Runways designed for take-offs with Runway Visual Range (RVR) less than 800 m.
3. Electric power supply connections to those facilities for which secondary power is required **should** be so arranged that the facilities are automatically connected to the secondary power supply on failure of the primary source of power.
4. The following aerodrome facilities **should** be provided with a secondary power supply capable of supplying power when there is a failure of the primary power supply:
 - a. The signalling lamp and the minimum lighting necessary to enable air traffic services personnel to carry out their duties;
 - b. Obstacle lights which are essential to ensure the safe operation of Air Systems;
 - c. Approach, runway and taxiway lighting as specified in Table 1;
 - d. Meteorological equipment and navigation aids;
 - e. Essential equipment and facilities for the parking position if provided, in accordance with the Aerodrome Emergency Plan; and
 - f. Illumination of apron areas over which passengers may walk.
5. The time interval between failure of the primary source of power and the complete restoration of the services required by Table 1 **should** be as short as practicable, except that for visual aids associated with non-precision, precision approach, or take-off runways the requirements of Table 1 for maximum switch-over times **should** apply.

Table 1. Secondary power supply requirements

| Acceptable Means of Compliance 3520(1) | Runway | Lighting aids requiring power | Maximum switch over time |
|---|--|--|--------------------------|
| | Non-instrument | Visual approach slope indicators ^a Runway edge ^b Runway threshold ^b Runway end ^b Obstacle ^a | 15 seconds |
| Non-precision approach | Approach lighting system Visual approach slope indicators ^{a, d} Runway edge ^d Runway threshold ^d Runway end Obstacle ^a | 15 seconds 15 seconds 15 seconds 15 seconds 15 seconds | |
| Precision approach category I | Approach lighting system Runway edge ^d Visual approach slope indicators ^{a, d} Runway threshold ^d Runway end Essential taxiway Obstacle ^a | 15 seconds 15 seconds 15 seconds 15 seconds 15 seconds 15 seconds | |
| Precision approach category II/III | Inner 300m of the approach lighting system Other parts of the approach lighting system Obstacle ^a Runway edge Runway threshold Runway end Runway centre-line Runway touchdown zone All stop bars Essential taxiway | 1 second 15 seconds 15 seconds 15 seconds 1 second 1 second 1 second 1 second 1 second 15 second | |
| Runway meant for take-off in runway visual range conditions less than a value of 800m | Runway edge Runway end Runway centre-line All stop bars Essential taxiway ^a Obstacle ^a | 15 seconds ^c 1 second 1 second 1 second 15 seconds 15 seconds | |

- a. Supplied with secondary power when their operation is essential to the safety of flight operation.
- b. See International Civil Aviation Organization (ICAO) Annex 14 Vol I regarding the use of emergency lighting.
- c. One second where no runway centre-line lights are provided.
- d. One second where approaches are over hazardous or precipitous terrain.

6. Requirements for a secondary power supply **should** be met by either of the following:

- a. Independent public power, which is a source of power supplying the aerodrome service from a substation other than the normal substation through a

Acceptable Means of Compliance 3520(1)

transmission line following a route different from the normal power supply route and such that the possibility of a simultaneous failure of the normal and independent public power supplies is extremely remote; or

b. Standby power units, which are engine generators, batteries, etc, from which electric power can be obtained.

7. Where a runway forming part of a standard taxi-route is provided with runway lighting and taxiway lighting, the lighting systems **should** be interlocked to preclude the possibility of simultaneous operation of both forms of lighting.
8. Where the secondary power supply of an aerodrome is provided using duplicate feeders, such supplies **should** be physically and electrically separate to ensure the required level of availability and independence.
9. A system of monitoring **should** be employed to indicate the operational status of the lighting systems.
10. Where lighting systems are used for Air System control purposes, such systems **should** be monitored automatically to provide an indication of any fault which may affect the control functions. This information **should** be automatically relayed to the air traffic services unit.
11. Where a change in the operational status of lights has occurred, an indication **should** be provided within two seconds for a stop bar at a runway-holding position and within five seconds for all other types of visual aids.

Guidance Material 3520(1)

Aerodrome Electrical System Design

12. The recommended current settings may be different for LED light units.
13. The Maximum Switchover Time is the time required for the actual intensity of a light measured in each direction to fall from 50% and recover to 50% during a power supply changeover, when the light is being operated at intensities of 25% or above.
14. In order to provide the Interleaving Aerodrome Ground Lighting (AGL) operational luminous intensity the AGL services are to be provided with a range of recommended output current steps in accordance with Table 2.

Table 2. Recommended AGL Luminous Intensity Control Stages

| Lighting Service | Information | 6 Stage Brilliancy (+NVG) | | | | | | | 2 Stage Brilliancy (+NVG) | | |
|--|----------------------|---------------------------|-------|------|----------------|------|------------------|-----|---------------------------|--|--|
| | | Max | 2 | 3 | 4 ^b | 5 | Min | NVG | | | |
| HI Approach | Luminous Intensity % | 100 | 30 | 10 | 3 | 1 | 0.3 ^a | - | | | |
| | Primary Current (A) | 12.0 | 9.72 | 8.28 | 7.08 | 6.12 | 5.28 | 2.8 | | | |
| Supplementary Approach | Luminous Intensity % | 100 | 30 | 10 | 3 | 1 | 0.3 | - | | | |
| | Primary Current (A) | 12.0 | 9.72 | 8.28 | 7.08 | 6.12 | 5.28 | N/A | | | |
| Wing Threshold | Luminous Intensity % | 100 | 30 | 10 | 3 | 1 | 0.3 ^a | - | | | |
| | Primary Current (A) | 12.0 | 9.72 | 8.28 | 7.08 | 6.12 | 5.28 | 2.8 | | | |
| Precision Approach Path Indicator (PAPI) | Luminous Intensity % | 100 | 80 | 30 | 10 | 3 | 1 | - | | | |
| | Primary Current (A) | 12.0 | 11.52 | 9.72 | 8.28 | 7.08 | 6.12 | N/A | | | |
| Touchdown Zone | Luminous Intensity % | 100 | 30 | 10 | 3 | 1 | 0.3 ^a | - | | | |
| | Primary Current (A) | 12.0 | 9.72 | 8.28 | 7.08 | 6.12 | 5.28 | N/A | | | |
| Rwy Centre-Line | Luminous Intensity % | 100 | 30 | 10 | 3 | 1 | 0.3 ^a | - | | | |
| | Primary Current (A) | 12.0 | 9.72 | 8.28 | 7.08 | 6.12 | 5.28 | N/A | | | |

Guidance Material 3520(1)

| | | | | | | | | | | | |
|--|----------------------|------|------|------|------|------|------------------|-----|------------------|------------------|-----|
| Threshold Bar | Luminous Intensity % | 100 | 30 | 10 | 3 | 1 | 0.3 ^a | - | | | |
| | Primary Current (A) | 12.0 | 9.72 | 8.28 | 7.08 | 6.12 | 5.28 | 3.2 | | | |
| HI Rwy Edge | Luminous Intensity % | 100 | 30 | 10 | 3 | 1 | 0.3 ^a | - | | | |
| | Primary Current (A) | 12.0 | 9.72 | 8.28 | 7.08 | 6.12 | 5.28 | 3.0 | | | |
| Rwy End Bar | Luminous Intensity % | 100 | 30 | 10 | 3 | 1 | 0.3 ^a | - | | | |
| | Primary Current (A) | 12.0 | 9.72 | 8.28 | 7.08 | 6.12 | 5.28 | 3.2 | | | |
| LI Rwy Edge | Luminous Intensity % | 100 | 30 | 10 | 3 | 1 | 0.3 ^a | - | | | |
| | Primary Current (A) | 12.0 | 9.72 | 8.28 | 7.08 | 6.12 | 5.28 | 3.2 | | | |
| | | | | | | | | | Max | Min | NVG |
| Twy Edge | Luminous Intensity % | | | | | | | | 100 | 10 | - |
| | Primary Current (A) | | | | | | | | 6.0 ^d | 4.4 ^d | - |
| Twy Centre-Line | Luminous Intensity % | | | | | | | | 100 | 10 | - |
| | Primary Current (A) | | | | | | | | 6.0 ^d | 4.4 ^d | 2.5 |
| <p>a. If required, this brilliancy stage may be replaced with a 0.05 stage (Primary Current 4.4A).</p> <p>b. Where NVG compatible lighting is operationally justified then the Stage 4 brilliancy stage may be omitted and Stages 4 and Min. moved up one stage with the new NVG setting being inserted at the Min. setting. The given primary currents may require adjusting to suit local environmental conditions.</p> <p>c. Where NVG compatible taxiway lighting is required an additional brilliancy stage is required. This will require the Modular Control System (MCS) to be modified.</p> <p>d. These current values may need to be adjusted where LED technology is used.</p> | | | | | | | | | | | |

15. The current control for an Illuminated Runway Distance to go Marker (IRDM) is to be in accordance with Table 3. Where LED technology is used, these values may need to be adjusted.

Table 3 IRDM Brilliancy Levels

| Brilliancy Levels and Current Values | | | | |
|--------------------------------------|------------|---|------------|--------------|
| Primary | | | Secondary | |
| Brilliancy % | Current(A) | | Current(A) | Brilliancy % |
| 100 | 12.0 | = | 6.60 | 100 |
| 30 | 9.72 | = | 6.60 | 100 |
| 10 | 8.28 | = | 6.34 | 80 |
| 3 | 7.08 | = | 5.90 | 50 |
| 1 | 6.12 | = | 5.02 | 20 |
| 0.3 | 5.28 | = | 4.55 | 10 |

Civil Equivalence.

16. This regulation is in line with ICAO Annex 14 Vol I para 8.1.

Regulation 3520(2)

Interleaving Aerodrome Ground Lighting

3520(2) HoEs and ADH Facing organizations **shall** ensure that the configuration of the electrical circuits that make up the AGL system is designed so that a failure of a single circuit will not cause a total lack of guidance.

Acceptable Means of Compliance 3520(2)

Interleaving Aerodrome Ground Lighting

17. Where interleaved circuits are provided, alternate lights **should** be connected to the same circuit. However, care needs be taken in the design of interleaved circuits to ensure that in the event of the failure of one or more circuits, a recognisable pattern and any colour coding is retained.

**Guidance
Material
3520(2)**

Interleaving Aerodrome Ground Lighting

18. Interleaving techniques are to be used where alternate light units and/or lamps are controlled separately. The minimum requirement is to be:

- a. At least two separate interleaved circuits for each of the following systems:
 - (1) Approach lighting (including Wing Threshold Bars) on precision approach runways;
 - (2) Supplementary approach lighting;
 - (3) High Intensity runway edge (including IRDM);
 - (4) High Intensity runway centre-line lighting;
 - (5) Touch down zone lighting;
 - (6) Runway end lighting;
 - (7) Low Intensity runway edge lighting; and
 - (8) Stop bar.
- b. At least one circuit for the following services:
 - (1) High Intensity simple approach lighting;
 - (2) Approach lighting on non-precision approach runways;
 - (3) Threshold;
 - (4) PAPI (Per Wing Bar); and
 - (5) Taxiway and apron edge lighting

19. Interleaved circuits may be provided for the services listed in sub-paragraph 18b to increase integrity or to overcome a technical difficulty. However, PAPI installations may be limited to two circuits per runway end.

Civil Equivalence.

20. This regulation is in line with ICAO Annex 14 Vol I para 8.2.

**Regulation
3520(3)**

Truck Runway Control Electrical Services

3520(3) HoEs and ADH Facing organizations **shall** ensure that when a runway control position is established, a suitable electrical supply is provided to support the Truck Runway Control (TRC).

**Acceptable
Means of
Compliance
3520(3)**

Truck Runway Control Electrical Services

21. Where a TRC is established, a minimum 16 Ampere, Residual Current Device (RCD) and Portable Emissions Measurement System (PEMS) protected, IP67, IEC 60309, switched socket outlet **should** be provided to enable an electrical supply suitable for the truck runway control, positioned as follows:

- a. On runway aerodromes - to the left or right of the runway a minimum of 45m from the runway edge and 70m from the threshold; and
- b. On non-runway aerodromes - at the downwind side of the airfield, and so positioned that two or more Air Systems may land simultaneously to the right of the truck with sufficient space available to the left of the truck to enable Air Systems to take off (left/right as seen by a pilot in the approach).

**Guidance
Material
3520(3)**

Truck Runway Control Electrical Services

22. Nil.

Intentionally Blank for Print Pagination

RA 3521 - Permanent Fixed Wing Aerodrome - Facilities

Rationale

The safety of operations at aerodromes is dependent on the quality of the various facilities available at the aerodrome. The facilities must be installed correctly if they are to have the desired effect. The promulgation of accurate information about the aerodromes facilities adds to the safety and accuracy of the Air Systems for which the aerodrome is intended.

Contents

3521(1): Air System Arresting Systems

3521(2): Runway Visual Range Systems

3521(3): Compass Calibration Bases ▶ ◀

3521(4): De-icing / Anti-icing

Regulation

3521(1)

Air System Arresting Systems

3521(1) Heads of Establishments (HoEs) and Aviation Duty Holder-Facing Organizations (ADH-Facing Organizations) **shall** ensure that information regarding installed Air System Arresting Systems is promulgated to all aerodrome users.

Acceptable Means of Compliance

3521(1)

Air System Arresting Systems

1. Aerodrome Operators **should** promulgate arrestor system details in the relevant Aeronautical Information Publications.

Guidance Material

3521(1)

Air System Arresting Systems

2. Clearance for Air Systems to engage arrestor systems or trample cables is published in 'Release To Service' documents and Aircrew Manuals.

Regulation

3521(2)

Runway Visual Range Systems

3521(2) HoEs and ADH-Facing Organizations **shall** ensure that Runway Visual Range (RVR) measurement and assessment is provided for airfields that perform low visibility operations.

Acceptable Means of Compliance

3521(2)

Runway Visual Range Systems

3. **Instrumental RVR (IRVR).** An IRVR system **should**:
- Consist of transmissometers appropriately located along the length of the runway;
 - Have an audited calibration of the forward-scatter meter trace and verified to a transmissometer standard; and
 - Have the accuracy of the system verified over the intended operational range.
4. **RVR.** Where instrumented RVR is not available, RVR for the purposes of category I and non-precision instrument approach operations **should** be assessed by human observer. However, the human observer assessment of RVR **should not** be permitted for Category II/III and Low Visibility Operations. A standard RVR assessment system utilising the human observer technique **should**:
- Utilize appropriate observation lights, the order of preference for which is, in descending order:
 - Opposite side runway edge lights;
 - Opposite side special reference lights;

Acceptable Means of Compliance 3521(2)

- (3) Same side runway edge lights; or
- (4) Same side special reference lights;
- (5) Where special reference lights are chosen, have reference lights:
 - (a) That are sited at approximately 60 m intervals from the observer to a distance of 800 m and at 100 m intervals between 800 and 1400 m unless otherwise restricted by airfield topography or layout;
 - (b) Separated from the runway edge lights by a maximum of 3 m;
 - (c) Pointed towards the observation point;
 - (d) Individually controlled from the observation point. In the event of a control failure each reference light **should** remain on;
 - (e) Arranged so as not to present a confusing or dangerous appearance to pilots; and
 - (f) Whose position is accurately determined as part of the aerodrome survey.
- b. Have a Runway Observation Point that:
 - (1) Comprises a cabin or similar facility mounted on a frangible tower;
 - (2) Is sighted in accordance with (iaw) Figure 1 and does not obscure a pilot's view of visual aids;
 - (3) Ensures the observer's eye-level is 15 ft above the ground;
 - (4) Is sited not more than 120 m laterally from the runway centreline and has had its position agreed upon by the aerodrome telecommunications officer;
 - (5) Is fitted with an observation panel subtending an angle of at least 30° horizontally and 30° vertically about the observer's line of sight when viewing the landing direction;
 - (6) Has direct communication between the observer and Air Traffic Control; and
 - (7) Is marked and lighted as an obstacle, according to RA 3518¹.
- c. Be sited iaw Figure 2.

Figure 1. RVR observation point sighting

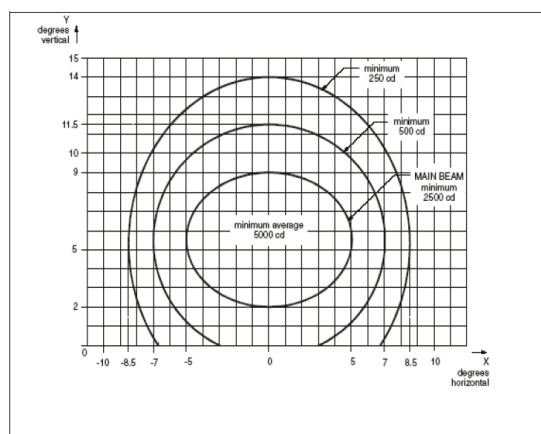

Notes: 1. Curves calculated on formula. $\frac{x^2}{a^2} + \frac{y^2}{b^2} = 1$

| | | | |
|---|-----|-----|-----|
| a | 5.0 | 7.0 | 8.5 |
| b | 3.5 | 6.0 | 8.5 |

2. Toe-in 4°.

Figure 2 RVR Siting Plan

¹ Refer to RA 3518 - Permanent Fixed Wing Aerodrome - Visual Aids for Denoting Obstacles.

Acceptable Means of Compliance 3521(2)

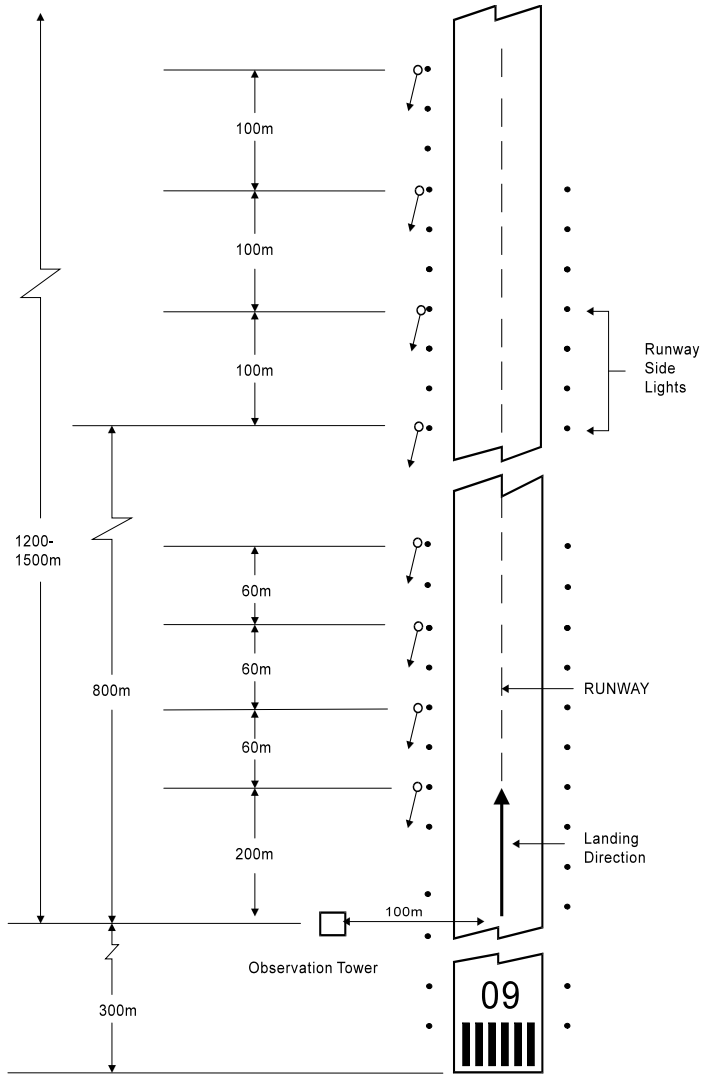

Guidance Material 3521(2)

Runway Visual Range Systems

5. Further information is contained within RA 3275².

Civil Equivalence.

6. This regulation is in line with International Civil Aviation Organization (ICAO) Annex 14 Vol I Annex 3.

Regulation 3521(3)

Compass Calibration Bases

3521(3) HoEs and ADH-Facing Organizations **shall** ensure that compass calibration bases are constructed to Class 1 or Class 2 requirements. The calibration base **shall** be an area of appropriate size to cater for the turning circle and all up weight of all Air Systems likely to be swung on that base and located sufficiently far from magnetic disturbances.

Acceptable Means of Compliance 3521(3)

Compass Calibration Bases

- 7. Classes:
 - a. Class 1 calibration bases **should** be utilised for Air Systems requiring refined or standard compass swings, as stipulated by the Air System operating authority.

² Refer to RA 3275 – Runway Visual Range.

**Acceptable
Means of
Compliance
3521(3)**

- b. Class 2 calibration bases **should** be utilized for standard compass swings only.
8. Construction:
- a. The size of the datum compass circle **should** be sufficient to allow the safe operation of the largest Air System to use the base. Typical radii are:
- (1) Large Air Systems (eg C-17) – 60 m;
 - (2) Medium Air Systems (eg Chinook) – 45 m; and
 - (3) Small Air Systems (eg Tutor) - 35 to 30 m.
9. The radius of the sterile area **should** be the radius of the datum compass circle plus 15 m.
10. The centre of the compass base **should** be at least 200 m from large buildings or continuous wire fences.
11. The compass base and access tracks **should**:
- a. Be constructed of non-ferrous concrete or bituminous material;
 - b. Be protected against fuel spillage;
 - c. Be constructed free from any magnetic material;
 - d. Be capable of withstanding the all-up weight of the heaviest Air System to be swung; and
 - e. Have a maximum gradient not exceeding 1 in 80.
12. Magnetic Deviation Limits **should** be no greater than:
- a. 0.1° at 1.5 m above ground level for Class 1 bases; and
 - b. 0.25° at 1.5 m above ground level for Class 2 bases.
13. No magnetic anomalies **should** be present in Class 1 bases.
14. The maximum allowable magnetic anomaly in a Class 2 base **should** be +/- 0.25° provided that:
- a. The anomaly **should** be clearly marked on the surface; and
 - b. The size and shape of the exclusion zone **should** be determined during routine magnetic surveys.
15. The datum compass circle is a narrow pathway used to position the datum compass. It **should** be clearly marked. The datum compass circle **should** comprise a continuous painted line on non-reinforced concrete or asphalt.

**Guidance
Material
3521(3)**

Compass Calibration Bases ▶◀

16. Further information and guidance on the location and construction of Compass Calibration bases can be obtained from QinetiQ, Land Magnetic Facilities³.
17. If a base will be used for Air Systems which have magnetic sensors below 1.5 m, a special survey may be required.
18. QinetiQ Land Magnetic facilities ▶ **need to** ◀ be notified at the earliest opportunity of any planned work within 200 m of the centre of the compass base.
19. Periodic surveys of all compass bases will be undertaken by staff from QinetiQ, Land Magnetic Facilities. Class 1 bases will be re-surveyed every 5 years. However, Class 2 bases are normally subject to magnetic anomalies, the effects of which are liable to change with time; these bases ▶ **need to** ◀ therefore be re-surveyed every 2 years.

³ LTPAenquiries@QinetiQ.com.

**Regulation
3521(4)**

De-icing / Anti-icing

3521(4) HoEs and ADH-Facing Organizations **shall** ensure that Air System de-icing / anti-icing facilities are provided.

**Acceptable
Means of
Compliance
3521(4)**

De-icing / Anti-icing

20. De-icing / anti-icing facilities **should** be in ICAO Annex 14, Volume I, Chapter 3, Section 15.
21. De-icing / anti-icing facilities **should** be provided either at Air System stands or at specified remote areas along the taxiway leading to the runway meant for take-off, provided that adequate drainage arrangements for the collection and safe disposal of excess de-icing / anti-icing fluids are available to prevent ground water contamination. The effect of volume of traffic and departure flow rates **should** also be considered.
22. The remote de-icing / anti-icing facility **should** be located outside of the obstacle limitation surfaces specified in RA 3512⁴, not cause interference to the radio navigation aids and be clearly visible from the air traffic control tower for clearing the treated Air System.
23. The remote de-icing / anti-icing facility **should** be so located as to provide for an expeditious traffic flow, perhaps with a bypass configuration, and **should not** require unusual taxiing manoeuvre into and out of the stand.
24. The size of a de-icing / anti-icing stand **should** be equal to the parking area required by the most demanding Air System in a given category with at least 3.8 m clear paved area all around the Air System for the movement of the de-icing / anti-icing vehicles.
25. The number of de-icing / anti-icing stand required **should** be determined based on the meteorological conditions, the type of Air System to be treated, the method of application of de-icing / anti-icing fluid, the type and capacity of the dispensing equipment used, and the departure flow rates.
26. The de-icing / anti-icing stand **should** be provided with suitable slopes to ensure satisfactory drainage of the area and to permit collection of all excess de-icing / anti-icing fluid running off an Air System. The maximum longitudinal slope **should** be as little as practicable and the transverse slope **should not** exceed 1%.
27. The de-icing / anti-icing stand **should** be capable of withstanding the traffic of the Air System it is intended to serve, due consideration being given to the fact that the de-icing / anti-icing pad (like an apron) will be subjected to a higher density of traffic and, as a result of slow-moving or stationary Air Systems, to higher stresses than a runway.
28. A de-icing / anti-icing stand **should** provide the minimum clearances specified in RA 3511⁵ for Air System stands. If the pad layout is such as to include bypass configuration, the minimum separation distances specified in Table 1, column 12, **should** be provided.
29. Where the de-icing / anti-icing facility is located adjoining a regular taxiway, the taxiway minimum separation distance specified in Table 1, column 11, **should** be provided (see Figure 3).

⁴ ▶ Refer to ◀ RA 3512 - Permanent Fixed Wing Aerodrome - Obstacle Environment.

⁵ ▶ Refer to ◀ RA 3511 - Permanent Fixed Wing Aerodrome – ▶ Physical characteristics. ◀

Acceptable Means of Compliance 3521(4)

Table 1. Taxiway minimum separation distances

| Code letter | Distance between taxiway centre-line and runway centre-line (metres) | | | | | | | | Taxiway centre-line to taxiway centre-line (metres) | Taxiway, other than Air System stand taxilane, centre-line to object (metres) | Air System stand taxilane centre line to aircraft stand taxilane centre line (metres) | Air System stand taxilane centre-line to object (metres) |
|-------------|--|------|-----|-------|------------------------------------|------|-----|-------|---|---|---|--|
| | Instrument runways Code number | | | | Non-instrument runways Code number | | | | | | | |
| | 1 | 2 | 3 | 4 | 1 | 2 | 3 | 4 | | | | |
| (1) | (2) | (3) | (4) | (5) | (6) | (7) | (8) | (9) | (10) | (11) | (12) | (13) |
| A | 82.5 | 82.5 | - | - | 37.5 | 47.5 | - | - | 23 | 15.5 | 19.5 | 12 |
| B | 87 | 87 | - | - | 42 | 52 | - | - | 32 | 20 | 28.5 | 16.5 |
| C | - | - | 168 | - | - | - | 93 | - | 44 | 26 | 40.5 | 22.5 |
| D | - | - | 176 | 176 | - | - | 101 | 101 | 63 | 37 | 59.5 | 33.5 |
| E | - | - | - | 182.5 | - | - | - | 107.5 | 76 | 43.5 | 72.5 | 40 |
| F | - | - | - | 190 | - | - | - | 115 | 91 | 51 | 87.5 | 47.5 |

Note 1 – The separation distances shown in columns (2) to (9) represent ordinary combinations of runways and taxiways. The basis for development of these distances is given in the Aerodrome Design Manual (ICAO Doc 9157), Part 2.

Note 2 – The distances in columns (2) to (9) do not guarantee sufficient clearance behind a holding Air System to permit the passing of another Air System on a parallel taxiway. See the Aerodrome Design Manual (ICAO Doc 9157), Part 2.

Figure 3. De-icing/anti-icing facility marking

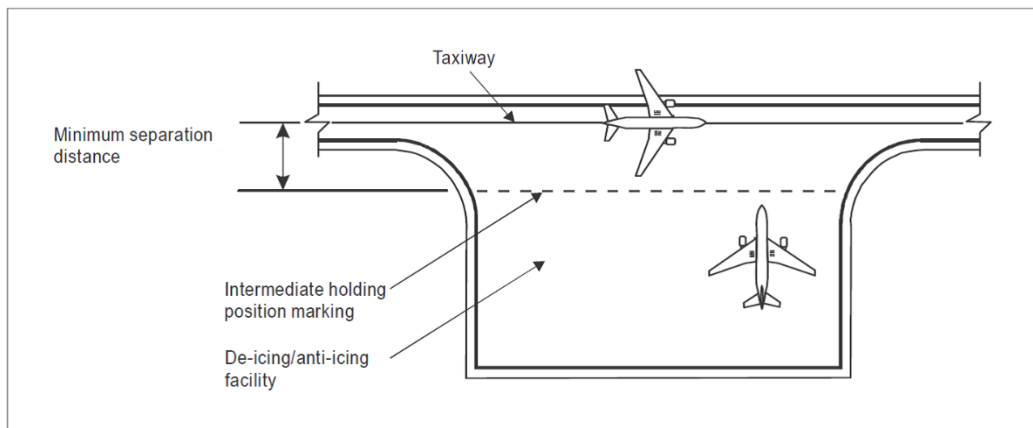

Guidance Material 3521(4)

De-icing / Anti-icing

30. One of the primary factors influencing the location of a de-icing / anti-icing facility is to ensure that the holdover time of the anti-icing treatment is still in effect at the end of taxiing and when take-off clearance of the treated Air System is given.

31. Remote facilities compensate for changing weather conditions when icing conditions or blowing snow are expected to occur along the taxi-route taken by the Air System to the runway meant for take-off.

32. The jet blast effects caused by a moving Air System on other Air Systems receiving the anti-icing treatment or taxiing behind ► need to ◀ be considered to prevent degradation of the treatment.

33. An Air System de-icing / anti-icing pad consists of:

- a. An inner area for parking of an Air System to be treated; and
- b. An outer area for movement of two or more mobile de-icing / anti-icing equipment.

34. Where more than one de-icing / anti-icing pad is provided, consideration ► needs to ◀ be given to providing de-icing / anti-icing vehicle movement areas of

**Guidance
Material
3521(4)**

adjacent pads that do not overlap, but are exclusive for each pad. Consideration will also need to be given to bypassing of the area by other Air Systems with the clearances specified in Table 1.

35. The excess de-icing / anti-icing fluid running off an Air System poses the risk of contamination of ground water in addition to affecting the pavement surface friction characteristics.

Civil Equivalence.

36. This regulation is in line with ICAO Annex 14 Vol I para 3.15.

Intentionally Blank for Print Pagination

RA 3522 – Permanent Fixed Wing Aerodrome – Vertical Landing Pads

Rationale

Vertical Landing Pads (VLP) may be established for proficiency training or to enable Aircraft recovery where conventional landing is not available. Without adequate provision for the design and safeguarding of the VLP, and supporting infrastructure, there is a Risk of unsafe operations. The purpose of this Regulatory Article (RA) is to provide a compliance framework that enables safe VLP operations to be conducted.

Contents

Scope

3522(1): Physical Characteristics

3522(2): Obstacle Environment

3522(3): Markings

3522(4): Lighting

3522(5): Signs

Scope

The purpose of this RA is to provide a baseline of requirements to enable the safe use of VLPs in support of F-35B operations at Main Operating Bases (MOBs). This initial issue will primarily support operations at RAF Marham, however it could be used to support installation of VLPs at other land-based locations. The requirements below have been derived from Design Specifications for the F-35B and combined, where applicable, with extant Regulatory requirements for airfield design and safeguarding.

Regulation

3522(1)

Physical Characteristics

3522(1) Heads of Establishments (HoEs), Aviation Duty Holder-Facing Organizations and Accountable Manager (Military Flying)– Facing Organizations (AA-Facing Organizations) **shall** ensure that VLPs enable the stabilised and safe use of the Aircraft for which they are intended.

Acceptable Means of Compliance

3522(1)

Physical Characteristics

1. The minimum dimensions of the VLP, Safety Zone and shoulder, **should** be in accordance (iaw) with Figure 1.
2. The VLP pavements and ancillary elements **should** be designed and constructed by Suitably Qualified and Experienced Persons / organizations, using the appropriate materials and construction methods to achieve the functional and geometric properties to meet the requirements of the intended platforms¹.
3. Surfaces bordering the paved shoulders **should** be assessed for resilience to jet blast, and where necessary engineered to maintain resilience to Foreign Object Damage / Debris, particularly important at first build due to the potential for disturbed natural surfaces during construction.
4. The siting of a VLP in relation to other Manoeuvring Areas, may be dictated by the space available, but **should** consider the unique wake turbulence characteristics of Short Take-Off Vertical Landing Aircraft² and the impact of this to adjacent Manoeuvring Areas.

¹ For F35B, facility requirements are owned by the F35 Joint Project Office.

² For further information, refer to RA 3277 – Wake Turbulence, para 31.

**Acceptable
Means of
Compliance
3522(1)**

Figure 1 – Vertical Landing Pad Dimensions.

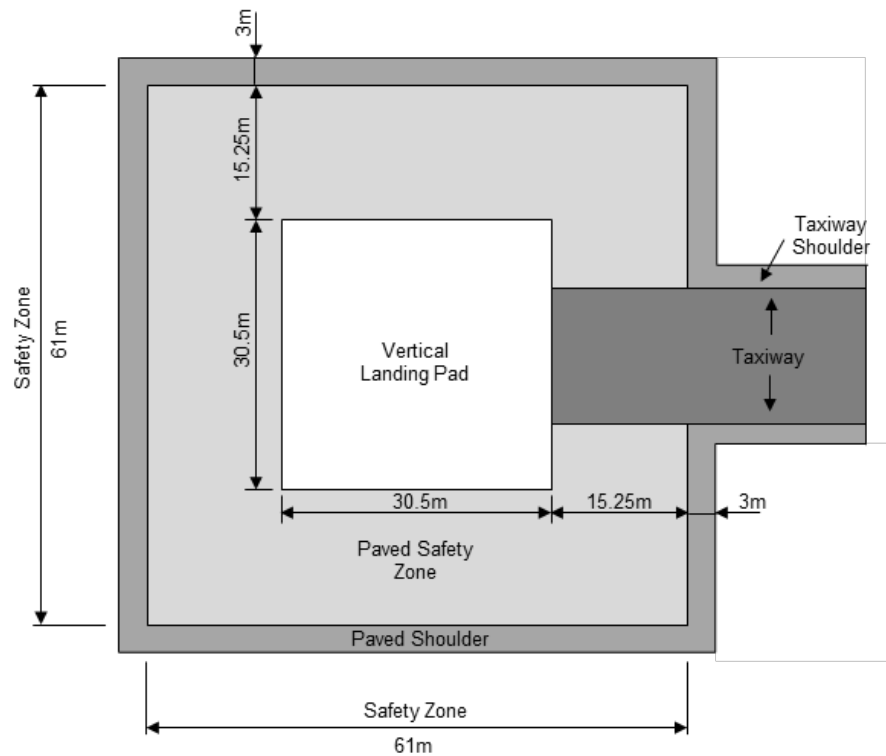

**Guidance
Material
3522(1)**

Physical Characteristics

5. The VLP and Safety Zones are established to prevent erosion of graded surfaces by jet blast from Aircraft transition to / from the pad and surface water runoff.
6. The use of F-35B VLPs by other Aircraft types is not prohibited, however, if the weight or performance characteristics of a different Aircraft type are likely to exceed the Design Specifications of the VLP, the unit may contact the Defence Infrastructure Organisation for advice.

**Regulation
3522(2)**

Obstacle Environment

- 3522(2) HoEs and AA-Facing Organizations **shall** establish VLP Obstacle Limitation Surfaces (OLS) for the following: primary zone, clear zone, Accident potential zone (APZ), transitional surface, approach surface and inner horizontal surface.

**Acceptable
Means of
Compliance
3522(2)**

Obstacle Environment

7. The OLS for VLPs **should** be a combination of surfaces and zones around the landing surface, as depicted at Figure 2.
8. **Primary Zone.** The primary zone **should** be:
 - a. A square measuring 300 x 300 ft (91.5 x 91.5 m) centred on, and at the same elevation as, the VLP.
 - b. Free of obstacles³.
 - c. Rough graded in the surface area beyond the paved surfaces, to the extent necessary to minimize damage to the Aircraft in the event of an emergency landing and to encourage drainage and avoid standing water.
9. **Clear zone.** The clear zone **should** be the same width as, and extend 400 ft (122 m) beyond, the primary zone and be centred on the primary approach path to the

³ Except where the obstacle is operationally essential – refer to RA 3590(12): Safeguarding – Operationally Essential Obstructions

Acceptable Means of Compliance 3522(2)

VLP. This area **should** be free of obstacles and graded to the extent necessary to prevent accumulation of water.

10. **APZ.** The APZ starts at the end of the clear zone, at the same width, and extend for 800 ft (244 m) in the direction of the approach path. This area **should** be kept free of obstacles as far as is practicable. Only frangible mounted obstacles, such as Aerodrome Ground Lighting (AGL) fittings, which are operationally essential, constructed and sited to reduce the Hazard to a minimum, **should** be used⁴.

11. **Transitional Surface.** The transitional surface is a complex surface that **should** originate from the four outer edges of the primary zone, extending uniformly upwards and outwards along slopes with a gradient of 2:1. The transitional surfaces end where they bisect the approach surfaces and / or inner horizontal surface.

12. **Approach Surface.** The approach surfaces **should**:

- a. Commence from the top of the Transitional Surface in the direction of approach, with continuing uniform divergence from the approach path centreline, at a rate of 15 degrees.
- b. Follow an incline slope with a gradient of 40:1.
- c. Be of sufficient length required to extend from the top of the Transitional Surface (150 ft) to 500 ft AGL.

13. **Inner Horizontal Surface.** The inner horizontal surface **should** be constructed by scribing a 180-degree (or more for multiple approaches) arc with a radius of 6,000 ft and with an elevation of 45 m from, the centre of the VLP. This imaginary surface covers the VFR landing pattern obstacle clearance requirements.

14. Where VLP OLS and Aerodrome OLS requirements overlap, the more stringent or lower surface **should** be used for assessment of obstacles.

Figure 2 – VLP Obstacle Limitation Surfaces

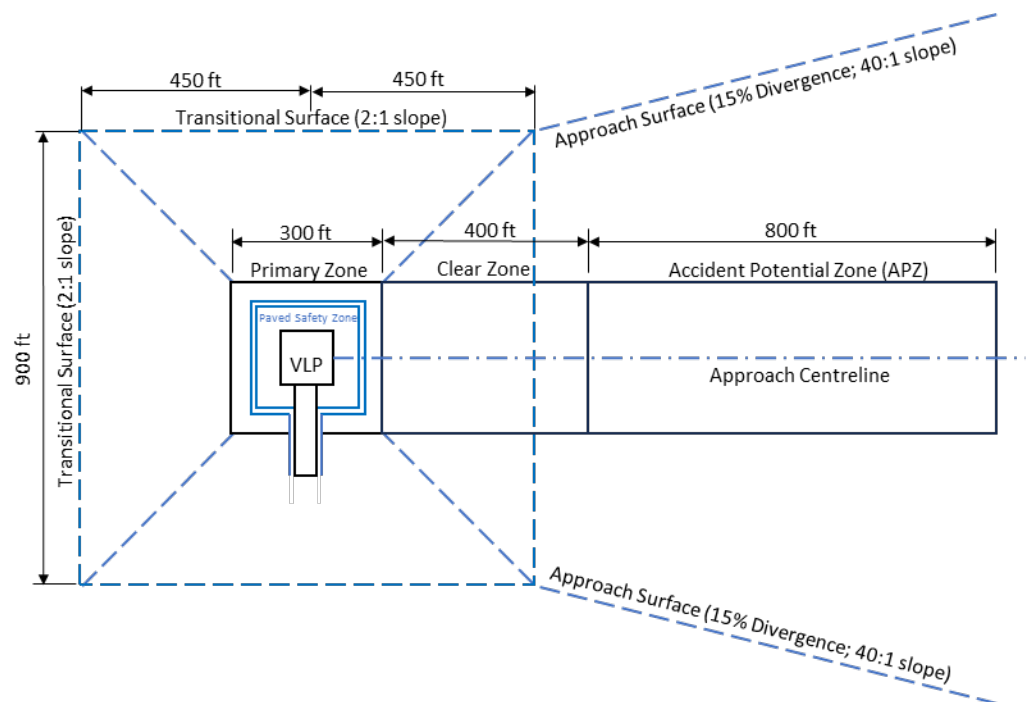

Note

The orientation presented here for the OLS, clear zone and APZ is for illustration only and will be otherwise determined by the actual direction of approach / departure. To support multiple directions of approach and departure and for

⁴ Refer to RA 3590 – Maintenance and Safeguarding, for further information on operationally essential obstructions.

**Acceptable
Means of
Compliance
3522(2)**

Aerodrome planning purposes, units may wish to consider zones based on a 360-degree area, or portion thereof, around the VLP.

**Guidance
Material
3522(2)**

Obstacle Environment

15. In the context of this Regulation, 'zones' refer to ground level, and 'surfaces' extend away from the VLP, upwards and outwards as depicted.

16. The VLP OLS requirements may be omitted in part or full where existing Aerodrome OLS meet or exceed the obstacle clearance requirements defined by the VLP OLS presented in this Regulation.

17. The VLP OLS requirements and supporting diagrams are based on a single direction of approach to the VLP. OLS may therefore be extended accordingly where more than one approach direction is used.

18. When the VLP is on or adjacent to an Aerodrome, the inner horizontal surface may be established to match the Aerodrome's inner horizontal surface.

19. When the VLP is located within the boundaries of an existing Aerodrome and the OLS of the two facilities overlap, the VLP transitional surface elevation will extend to meet the existing inner horizontal surface elevation of the Aerodrome.

20. When the VLP is located within the Runway Strip of an existing Runway, use of the Runway approach / departure surface may suffice for the VLP approach surface provided a visual transition between the path and the VLP can be conducted while under Visual Meteorological Conditions.

**Regulation
3522(3)**

Markings

3522(3) HoEs and AA-Facing Organizations **shall** ensure that clearly defined markings are provided to allow safe movement on and in the vicinity of the VLP by vehicles and Aircraft.

**Acceptable
Means of
Compliance
3522(3)**

Markings

21. VLP markings **should** be a combination of white and yellow iaw the scheme and dimensions shown at Figure 3.

22. Adjoining taxiways and roads **should** be marked iaw RA 3514⁵.

23. VLP holding position markings **should** follow the conventions for a Runway holding position type A, as provided in RA 3514⁵. The distance of the holding position from the VLP **should** be not less than the outer edge of the primary zone (91.5 m) but **should** be extended if jet downwash is likely to endanger a waiting Aircraft or vehicle.

24. The use of VLP ahead markings **should** be considered as shown in Figures 3 and 4.

25. Where a Mechanical Transport route joins a VLP, vehicle holding positions **should** be located outside the Primary Zone (91.5m) or at a suitable distance to ensure waiting vehicles are not endangered by jet downwash.

26. Markings **should** be made with materials having similar wet friction qualities to those of the surrounding paved surfaces.

⁵ Refer to RA 3514 – Permanent Fixed Wing Aerodromes – Markings.

Acceptable
Means of
Compliance
3522(3)

Figure 3 - Vertical Landing Pad Markings

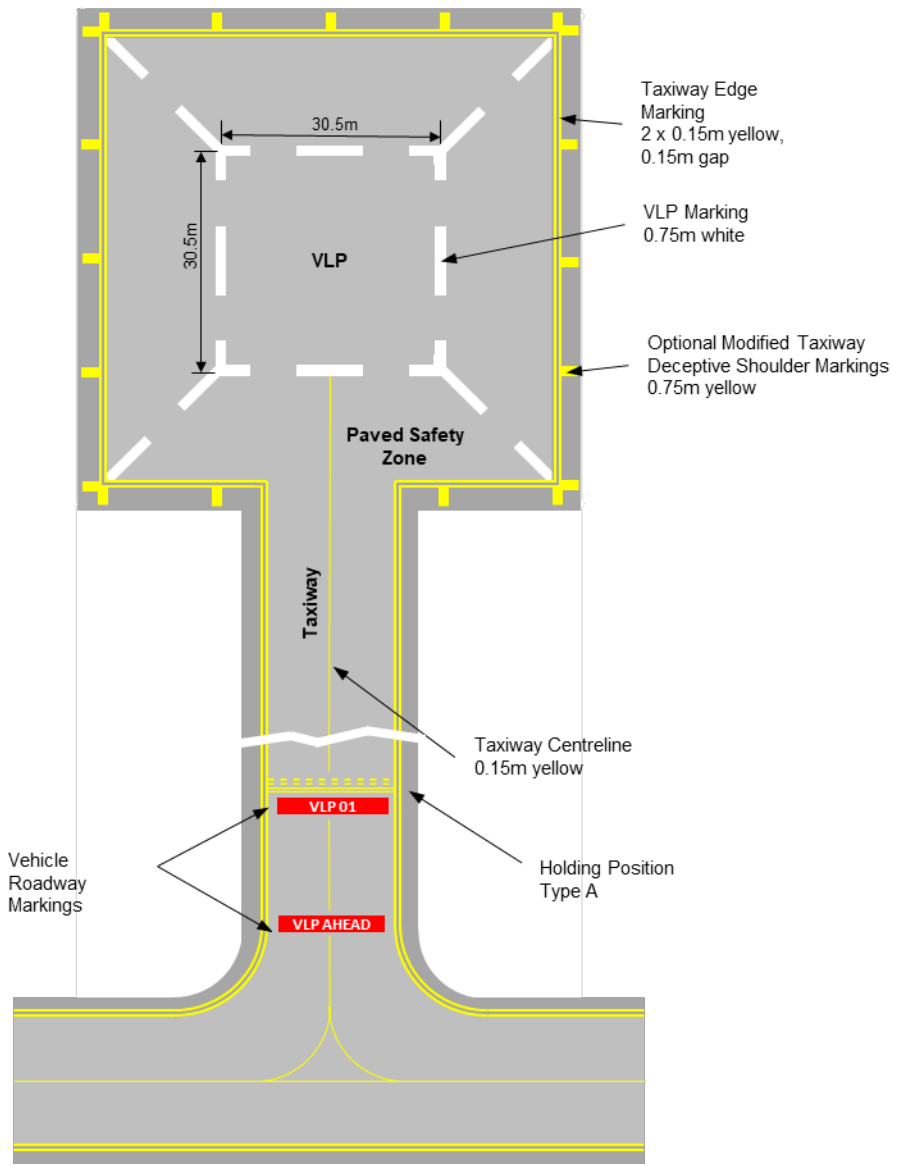
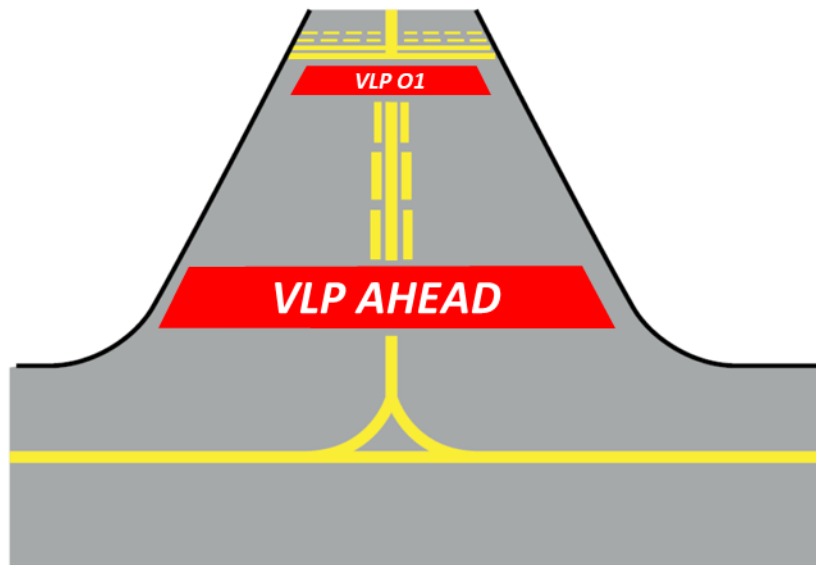

Figure 4 - Vertical Landing Pad Ahead Markings



**Guidance
Material
3522(3)**

Markings

27. Full size VLP designators are not mandated, however where multiple VLPs are available they may be added if the unit assesses there is a risk of confusion.
28. The VLP Ahead markings depicted at Figure 3 and 4, will be legible to both vehicles and Aircraft.
29. Black outlining (at least 0.15 m in width) may be provided where there is insufficient background contrast.
30. Colour specifications for paints can be found in BS 381C and colour specifications for signs and surface markings are for reflective materials are prescribed in BS EN 12899-1:2007.

**Regulation
3522(4)**

Lighting

- 3522(4) HoEs and AA-Facing Organizations **shall** ensure that the VLPs lights are provided to support Aircraft movements during low visibility and night operations.

**Acceptable
Means of
Compliance
3522(4)**

Lighting

31. VLP AGL **should**:
- Provide adequate guidance to indicate the layout and corners of the VLP Safety Zone.
 - Be of a different colour to the adjoining taxiway (orange is advocated) to ensure clear delineation of the surfaces.
 - Have intensity and distribution characteristics consistent with surrounding AGL and compatible with Night Vision Operations if required.
 - Be controlled by Air Traffic Control (ATC), with individual control of each VLP available.
32. Adjoining taxiways **should** be lit iaw RA 3515⁶.
33. **Parallax Markers.** Where parallax markers are provided to assist the pilot when executing a vertical landing, they **should** be:
- Arranged and optimized to provide sufficient guidance to enable a pilot to carry out a safe and accurate vertical landing.
 - Uni-directional.
 - Visible throughout the hovering height band of 0-200 ft AGL.
 - Robustly constructed to withstand transitional jet downwash from an Aircraft approaching the VLP at 150-200 ft AGL.
 - The minimum height required to function as intended.
34. When used to support night flying, parallax markers **should** be illuminated and, if required, compatible with applicable Night Vision Operations.

**Guidance
Material
3522(4)**

Lighting

35. The recommended layout for VLP AGL is at Figure 5.
36. The requirement for individual control of each VLP enables visual reinforcement of the active VLP and, particularly at night, avoids unnecessary use of AGL and reduces the likelihood of confusion.
37. The recommended layout for parallax markers, to support F-35B, is at Figure 6 and as follows:

⁶ Refer to RA 3515 – Permanent Fixed Wing Aerodrome – Lighting, sub-regulation 17.

**Guidance
Material
3522(4)**

- a. An inner marker positioned 120 m from the centre of the VLP on a line extending through each corner.
 - b. An outer marker positioned at 160 m from the centre of the VLP on a line extending through each corner.
 - c. The colour to be used for parallax marker is not specified and may be determined by local requirements, provided that the lights are not dangerous or confusing to users of adjacent surfaces.
38. Where the recommended parallax marker configuration cannot be achieved due to space constraints the pattern may be adjusted, provided that the required visual references are still achieved to enable a safe approach.

Figure 5 – VLP AGL Layout

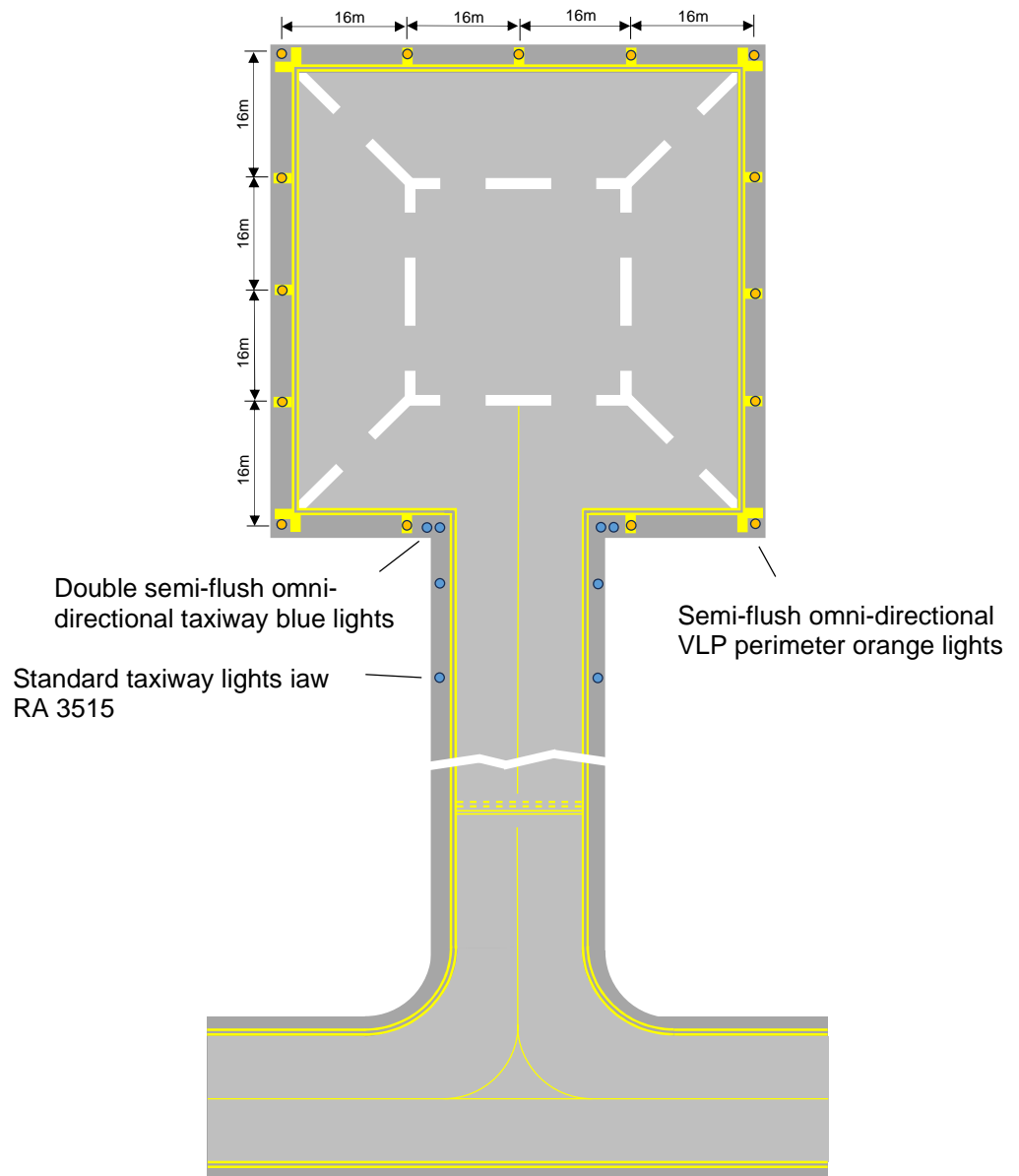

**Guidance
Material
3522(4)**

Figure 6 – Parallax Marker Layout (not to scale)

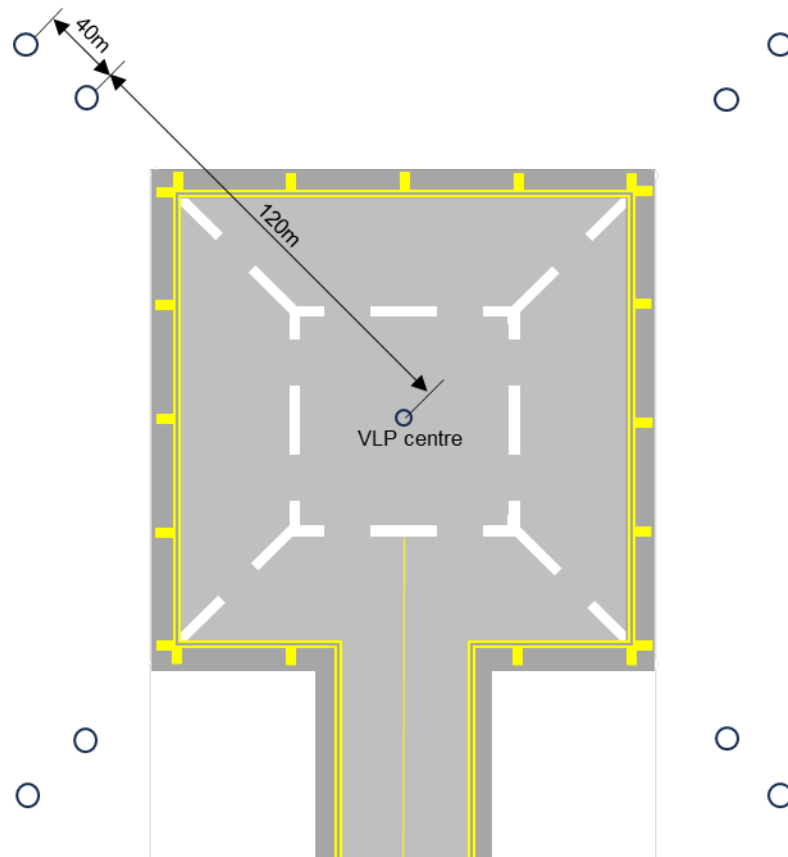

**Regulation
3522(5)**

Signs

- 3255(5) HoEs and AA-Facing Organizations **shall** ensure that mandatory instruction signs are provided to identify the location beyond which an Aircraft or vehicle is not to proceed unless authorized by ATC.

**Acceptable
Means of
Compliance
3522(5)**

Signs

39. VLP mandatory instruction signs **should** be installed iaw RA 3516(1)(2)⁷.
40. As a minimum, the following signs **should** be installed at MOBs where VLPs are in operation:
- VLP designation signs.
 - Holding position signs.
 - Road holding position signs.
41. VLP signs **should** be illuminated and / or retro-reflective iaw the provisions of International Civil Aviation Organization (ICAO) Annex 14 Vol I Appendix 4, when intended for use at night.

**Guidance
Material
3522(5)**

Signs

42. VLP naming and numbering conventions may be determined at unit discretion.
43. The decision to install either illuminated signs or retro-reflective signs will be determined by operational requirements, however it is recommended that VLP signage is consistent with the provisions on surrounding surfaces.

⁷ Refer to RA 3516(1): General and RA 3516(2): Mandatory Instruction Signs.

RA 3530 - Helicopter Landing Site - Reference Information

Rationale

A common reference system, reference codes and aerodrome data is required to inform the operational community of key information about Helicopter Landing Sites (HLS). The accuracy and integrity of aeronautical data is essential to support safe operations in and around the aerodrome.

Contents

- 3530(1): Helicopter Landing Sites Regulatory Framework
- 3530(2): Permanent Helicopter Landing Sites - Common Reference System
- 3530(3): Permanent Helicopter Landing Sites - Helicopter Performance Class
- 3530(4): Permanent Helicopter Landing Sites - Aeronautical Data

Regulation 3530(1)

Helicopter Landing Sites Regulatory Framework

3530(1) Heads of Establishments (HoEs) and Aviation Duty Holder-Facing Organizations (ADH-Facing Organizations) **shall** ensure that the specifications in the RA 3530 Series and RA 3590¹ apply to all HLS under MAA regulation. They **shall** apply equally to areas meant for the exclusive use of helicopters at an aerodrome primarily meant for the use of fixed wing Air Systems.

Acceptable Means of Compliance 3530(1)

Helicopter Landing Sites Regulatory Framework

1. Where an aerodrome has a permanent helicopter presence, the requirements of the RA 3530 Series and RA 3590 **should** be applied, unless the requirement explicitly states that it is for a Domestic HLS².
2. Where an aerodrome operates both fixed and rotary wing assets, areas for the exclusive use of rotary wing assets **should** conform to the requirements of the RA 3530 Series and RA 3590, unless the requirement explicitly states that it is for a Domestic HLS.
3. The RA 3530 Series of regulations applies only to single-main-rotor helicopters. For tandem-rotor helicopters the heliport design **should** be based on a case by case review of the specific models using the basic requirement for a safety area and protection areas specified in these regulations.

Guidance Material 3530(1)

Helicopter Landing Sites Regulatory Framework

4. Three types of HLS are defined:
 - a. Permanent HLS: A Permanent HLS (also referred to as a "heliport" in MAA02³) is a facility with a permanent rotary wing presence which is designated for operating, basing, servicing and maintaining helicopters. It may be either at home or overseas. It may be an entire aerodrome or a defined area within an aerodrome. It may contain one or more landing points.
 - b. Domestic HLS: A Domestic HLS is a facility where there is no permanent rotary wing presence which is designated only for the movement of passengers, crew, cargo or training and no other activities take place (eg Maintenance). It may be either at home or overseas. It may contain one or more landing points.
 - c. Temporary / Tactical HLS: A Temporary facility designated for the movement of passengers, crew or cargo during times of tension, operations, training or exercise. It may also be used for basing, servicing and/or

¹ Refer to RA 3590 – Maintenance and Safeguarding.

² See paragraph 4b.

³ Refer to MAA02: Military Aviation Authority Master Glossary.

**Guidance
Material
3530(1)**

maintaining helicopters. It may be located within the UK or overseas. It may be an entire aerodrome, a defined area within an aerodrome, or any other designated location. It may include one or more landing points.

5. RA 3530 regulations do not apply to elevated heliports, helidecks or shipboard helidecks. Advice on these sites can be obtained from the Heliport Manual⁴.

Civil Equivalence.

6. This regulation is in line with International Civil Aviation Organization (ICAO) Annex 14 Vol II para 1.2.

**Regulation
3530(2)**

Permanent Helicopter Landing Sites - Common Reference System

3530(2) HoE and ADH-Facing Organizations **shall** ensure that a common reference system for Horizontal, Vertical and Temporal measurements is to be defined.

**Acceptable
Means of
Compliance
3530(2)**

Permanent Helicopter Landing Sites - Common Reference System

7. For a Horizontal reference system, the World Geodetic System - 1984 (WGS-84) **should** be used. Reported aeronautical geographical coordinates (indicating latitude and longitude) **should** be expressed in terms of the WGS-84 geodetic reference datum.

8. **▶◀ Mean Sea Level ▶Datum◀ should** be used as the Vertical reference system.

9. For a Temporal reference system, the Gregorian calendar and Coordinated Universal Time (UTC) **should** be used.

**Guidance
Material
3530(2)**

Permanent Helicopter Landing Sites - Common Reference System

Civil Equivalence.

10. This regulation is in line with ICAO Annex 14 Vol II para 1.3.

**Regulation
3530(3)**

Permanent Helicopter Landing Sites - Helicopter Performance Class

3530(3) HoE and ADH-Facing Organizations **shall** ensure that the categorization of Permanent HLS movement areas is defined by the Performance Class of the design helicopter.

**Acceptable
Means of
Compliance
3530(3)**

Permanent Helicopter Landing Sites - Helicopter Performance Class

11. Performance Classes **should** be assigned as follows:

a. Class 1 - Multi-Engine Helicopter capable of maintaining flight with One Engine Inoperative after reaching Critical Decision Point (CDP).

(1) Prior to CDP loss of engine forces helicopter to make a controlled landing. A suitable clearway of either land or water is required.

b. Class 2 - Helicopter capable of maintaining a safe height after an engine failure during most phases of flight (eg cruise) but are forced to land if an engine fails during the initial phase of take-off or during the final stages of landing.

(1) Dependant on payload and temperature.

(2) Some multi-engine helicopters even if capable of operating at Performance Class 1, may be operated at a higher payload at this class.

⁴ ▶ Refer to ◀ Heliport Manual – ICAO Doc 9261.

**Acceptable
Means of
Compliance
3530(3)**

- c. Class 3 - Single engine helicopter, or multi-engine helicopters operating beyond Class 1 and 2 payload limits, where a forced landing would, in all cases, have to be made in the event of engine failure.

**Guidance
Material
3530(3)**

Permanent Helicopter Landing Sites - Helicopter Performance Class

12. Nil.

**Regulation
3530(4)**

Permanent Helicopter Landing Sites – Aeronautical Data

- 3530(4) HoE and ADH-Facing Organizations **shall** ensure that the following attributes of the Permanent HLS are established and reported to the Aeronautical Information Services (AIS); HLS Reference Point; HLS Elevations; HLS Dimensions; and Declared Distances.

**Acceptable
Means of
Compliance
3530(4)**

Permanent Helicopter Landing Sites - Aeronautical Data

13. When the Permanent HLS or landing location is collocated with an aerodrome, the established aerodrome reference point **should** serve both aerodrome and HLS or landing location.
14. The Permanent HLS Reference point **should**:
- Be established for a HLS or a landing location not collocated with an aerodrome;
 - Be located near the initial or planned geometric centre of the HLS or landing location and **should** normally remain where first established; and
 - Be measured and reported to the aeronautical information services authority in degrees, minutes and seconds.
15. The Permanent HLS Elevation **should**:
- Also include the geoid undulation at the HLS elevation; and
 - Be measured and reported to the AIS to the accuracy of one-half metre or foot.
16. The following Permanent HLS Dimensions and related information **should** be reported:
- HLS type - surface-level, elevated, shipboard or helideck;
 - Touchdown and Lift-Off Area (TLOF) - dimensions to the nearest metre or foot, slope, surface type, bearing strength in tonnes (1000 kg);
 - Final Approach and Take Off (FATO) - type of FATO, true bearing to one-hundredth of a degree, designation number (where appropriate), length and width to the nearest metre or foot, slope, surface type;
 - Safety area - length, width and surface type;
 - Helicopter ground taxiway and helicopter air taxiway - designation, width, surface type;
 - Apron - surface type, helicopter stands;
 - Clearway - length, ground profile; and
 - Visual aids for approach procedures, marking and lighting of FATO, TLOF, helicopter ground taxiways, helicopter air taxiways and helicopter stands.
17. The following geographical coordinates **should** be measured and reported to the AIS in degrees, minutes, seconds and hundredths of seconds:

**Acceptable
Means of
Compliance
3530(4)**

- a. The geometric centre of the TLOF and/or of each threshold of the FATO (where appropriate);
 - b. Appropriate centre-line points of helicopter ground taxiways and helicopter air taxiways;
 - c. Each helicopter stand; and
 - d. Obstacles within the aerodrome boundary.
18. In addition, the top elevation, type, marking and lighting (if any) of obstacles **should** be reported to the AIS.
19. The following distances to the nearest metre or foot **should** be declared, where relevant, for a Permanent HLS:
- a. Take-off distance available;
 - b. Rejected take-off distance available; and
 - c. Landing distance available.
20. Aeronautical Data quality requirements **should** be in accordance with ICAO Annex 14. Volume I, Appendix 5.
21. Every effort **should** be made to ensure that the integrity of aeronautical data is maintained throughout the data process from survey / origin to the next intended user.

**Guidance
Material
3530(4)****Permanent Helicopter Landing Sites - Aeronautical Data
Civil Equivalence.**

22. This regulation is in line with ICAO Annex 14 Vol II para 2.2 – 2.5.

RA 3531 - Helicopter Landing Site - Physical Characteristics

Rationale

The physical characteristics of a Helicopter Landing Site (HLS) are defined to reduce the Risk associated with an Air System flying over it, and when taking-off or landing, including: when taxiing, during an Incident or Accident scenario, to enable safe use by rescue and firefighting vehicles, when loading and unloading Passengers, crew and cargo, and when servicing.

Contents

- 3531(1): Permanent Helicopter Landing Site - Final Approach and Take Off area
- 3531(2): Permanent Helicopter Landing Site - Clearway
- 3531(3): Permanent Helicopter Landing Site - Touchdown and Lift Off area
- 3531(4): Permanent Helicopter Landing Site - Safety Area
- 3531(5): Permanent Helicopter Landing Site - Ground Taxiway
- 3531(6): Permanent Helicopter Landing Site - Air Taxiway
- 3531(7): Permanent Helicopter Landing Site - Air Transit Route - Design
- 3531(8): Permanent Helicopter Landing Site - Apron
- 3531(9): ► **Withdrawn – Incorporated into RA 3536(1): Domestic Helicopter Landing Sites – General Requirements** ◀

Regulation 3531(1)

Permanent Helicopter Landing Site - Final Approach and Take Off area

3531(1) Heads of Establishments (HoEs) and Aviation Duty Holder-Facing Organizations (ADH-Facing Organizations) **shall** ensure that Final Approach and Take Off areas (FATO) are provided at an HLS.

Acceptable Means of Compliance 3531(1)

Permanent Helicopter Landing Site - Final Approach and Take Off area

1. **Location.** The FATO **should** be located to minimize the influence of the surrounding environment, including turbulence, which could have an adverse impact on helicopter operations. Where a FATO is located near a Runway or taxiway, and where simultaneous operations are planned, the separation distance between the edge of a Runway or taxiway and the edge of a FATO **should** be as prescribed in Table 1.

Table 1. FATO minimum separation distance

| If Air System mass and / or helicopter mass are | Distance between FATO edge and Runway edge or taxiway edge |
|---|--|
| Up to but not including 3175 kg | 60 m |
| 3175 kg up to, but not including, 5760 kg | 120 m |
| 5760 kg up to, but not including, 100,000 kg | 180 m |
| 100,000 kg and over | 250 m |

2. A FATO **should** be located away from:

- a. Taxiway intersections or holding points where jet engine efflux is likely to cause high turbulence; and
- b. Areas where Air System vortex wake generation is likely to exist.

**Acceptable
Means of
Compliance
3531(1)**

3. **Dimension.** The dimensions of a FATO for Class 1 Helicopters **should** be:
 - a. As defined in the Helicopter Flight Manual; and
 - b. Of no smaller width than the largest overall dimension of the helicopter it is intended to serve.
4. The dimensions of a FATO for Class 2 or 3 Helicopters **should** be:
 - a. $1D^1$ of the largest helicopter when the Maximum Take-Off Mass (MTOM) of helicopters the FATO is intended is more than 3175 kg;
 - b. $0.83D$ of the largest helicopter when the MTOM of helicopters the FATO is intended to serve is 3175 kg or less.
5. **Slope.** The slope **should** be designed to promote the most rapid drainage of water from the FATO.
6. The mean slope of the FATO, in any direction, **should not** exceed 3%.
7. No portion of a FATO **should** have a local slope exceeding:
 - a. 5% where the HLS is intended to be used by helicopters operated in performance Class 1; and
 - b. 7% where the HLS is intended to be used by helicopters operated in performance Class 2 or 3
8. **Surface.** The surface of the FATO **should**:
 - a. Be constructed without characteristics that would adversely affect the Safety of the helicopter operating from the FATO.
 - b. Be resistant to the effects of rotor downwash;
 - c. Be free of irregularities that would adversely affect the take-off or landing of helicopters;
 - d. Have bearing strength sufficient to accommodate a rejected take-off by helicopters operated in performance Class 1; and
 - e. Provide ground-effect.
9. The surface of a FATO surrounding a Touchdown and Lift Off area (TLOF) intended for use by helicopters operated in performance Classes 2 and 3 **should** be static load-bearing.

**Guidance
Material
3531(1)**

Permanent Helicopter Landing Site - Final Approach and Take Off area

10. Local conditions, such as elevation and temperature, may need to be considered when determining the size of a FATO.
11. If turbulence mitigating design measures are warranted but not practical, operational limitations may need to be considered under certain wind conditions.

Civil Equivalence.

12. This Regulation is in line with ICAO Annex 14 Vol II para 3.1.

**Regulation
3531(2)**

Permanent Helicopter Landing Site - Clearway

- 3531(2) HoEs and ADH-Facing Organizations **shall** ensure that a Clearway is provided for Aerodromes intended for Performance Class 1 Helicopters.

¹ Where D is the largest overall dimension of the helicopter using the HLS.

**Acceptable
Means of
Compliance
3531(2)**

Permanent Helicopter Landing Site - Clearway

13. **Location.** The Clearway **should** be located beyond the end of the FATO.
14. **Dimension.** The width of a Clearway **should** be no less than that of the associated Safety Area².
15. **Slope.** The ground in a Clearway **should** remain below a plane having an upward slope of 3%, the lower limit of this plane being a horizontal line which is located on the periphery of the FATO.

**Guidance
Material
3531(2)**

Permanent Helicopter Landing Site - Clearway

16. A clearway is not required for Performance Class 2 and 3 helicopters.
- Civil Equivalence.**
17. This Regulation is in line with ICAO Annex 14 Vol II para 3.1.

**Regulation
3531(3)**

Permanent Helicopter Landing Site - Touchdown and Lift Off area

- 3531(3) HoEs and ADH-Facing Organizations **shall** ensure that one TLOF is located within the FATO, or that one or more TLOFs are to be collocated with helicopter stands.

**Acceptable
Means of
Compliance
3531(3)**

Permanent Helicopter Landing Site - Touchdown and Lift Off area

18. **Location.** Where a TLOF is located within a FATO which can contain a circle of diameter more than 1D, the centre of the TLOF **should** be located not less than 0.5D from the edge of the FATO.
19. **Dimension.** The TLOF **should** be of sufficient size to contain a circle of diameter of at least 0.83D of the largest helicopter the area is intended to serve.
20. **Slope.** The TLOF surface **should** be designed to promote the most rapid drainage of water from the TLOF. The slope of the TLOF **should** be no greater than 2% in any direction
21. **Surface.** The surface of a TLOF **should** be constructed without characteristics that would adversely affect the Safety of the helicopter operating from the TLOF.
22. Where the TLOF is within the FATO, the TLOF **should** be dynamic load-bearing.
23. Where a TLOF is collocated with a helicopter stand, the TLOF **should** be static load-bearing and capable of withstanding the traffic of helicopters that the area is intended to serve.

**Guidance
Material
3531(3)**

Permanent Helicopter Landing Site - Touchdown and Lift Off area

24. For Runway-type FATOs, additional TLOFs located in the FATO are acceptable.
- Civil Equivalence.**
25. This Regulation is in line with ICAO Annex 14 Vol II para 3.1.

**Regulation
3531(4)**

Permanent Helicopter Landing Site - Safety Area

- 3531(4) HoEs and ADH-Facing Organizations **shall** ensure that a FATO is surrounded by a Safety Area.

² ▶ Refer to ◀ RA 3531(4): ▶ Permanent Helicopter Landing Site - Safety Area. ◀

**Acceptable
Means of
Compliance
3531(4)**

Permanent Helicopter Landing Site - Safety Area

26. **Dimension.** For Visual Meteorological Conditions operations, the Safety Area **should** extend outwards from the periphery of the FATO for a distance of at least 3 m or 0.2D, whichever is greater, of the largest helicopter the FATO is intended to serve and:

- a. Each external side of the Safety Area **should** be at least 2D where the FATO is quadrilateral; or
- b. The outer diameter of the Safety Area **should** be at least 2D where the FATO is circular.

27. For Instrument Meteorological Conditions operations, the Safety Area **should** extend at least:

- a. 45 m either side of the FATO centre-line; and
- b. 60 m beyond the FATO ends.

28. **Slope.** The surface of the Safety Area, when solid, **should** have an upward slope no greater than 4% outwards from the edge of the FATO.

29. **Surface.** Where applicable, the surface of the Safety Area **should** be treated to prevent flying debris caused by rotor downwash.

30. When solid, the surface of the Safety Area abutting the FATO **should** be continuous with the FATO and capable of supporting the design helicopter without structural damage.

**Guidance
Material
3531(4)**

Permanent Helicopter Landing Site - Safety Area

31. The surface of the Safety Area need not be solid.

Civil Equivalence.

32. This Regulation is in line with ICAO Annex 14 Vol II para 3.1.

**Regulation
3531(5)**

Permanent Helicopter Landing Site - Ground Taxiway

3531(5) HoEs and ADH-Facing Organizations **shall** ensure that, where required, a helicopter Ground Taxiway is provided to cater for the largest helicopter intended for use at the HLS.

**Acceptable
Means of
Compliance
3531(5)**

Permanent Helicopter Landing Site - Ground Taxiway

33. **Location.** For simultaneous operations, helicopter Ground Taxiway **should not** overlap.

34. Minimum separation distances between helicopter Ground Taxiways and other taxiways, objects and helicopter stands **should** be as per Table 2.

Table 2. Separation Distances (expressed in multiples of maximum design helicopter overall dimension with rotors turning)

| Facility | Helicopter Ground Taxiway ^a | Air Taxiway ^a | Object ^b | Helicopter Stand ^{cdefg} |
|--------------------------------|--|--------------------------|---------------------|-----------------------------------|
| Helicopter Ground Taxiway | 2 | 3 | 1.25 | 1.75 |
| Air Taxiway | 3 | 3 | 1.5 | 2.5 |
| Object | 1.25 | 1.5 | - | 1.25 (1.5) |
| Helicopter Stand ^{cd} | 1.75 | 2.5 | 1.25 (1.5) | 1.5 (1.75) |

Note:

^a Centre-line to centre-line

^b Centre-line to edge of object

**Acceptable
Means of
Compliance
3531(5)**

^c Centre-line to centre

^d Stands with through ground taxi access. Figures in () for through hover taxi access

^e Simultaneous hover operations in/out of stands are equivalent to 2 x Air Taxiway operations

^f Stands may require increased spacing to that shown to allow for manoeuvring of helicopters on the stands, either because there isn't through access or because there is a need to manoeuvre helicopters to park them headed into wind.

^g Stands without through access, no part of the turning helicopter to overlap the adjacent stand clearance and helicopter to come to rest parked centrally pointing perpendicular to the line of the stands.

35. **Dimension.** The width of a helicopter Ground Taxiway **should** be no less than 1.5 times the largest Undercarriage Width (UCW) of the helicopters the helicopter Ground Taxiway is intended to serve.

36. Horizontal helicopter Ground Taxiway curves **should** be compatible with the design helicopter and with a centre-line radius of no less than 20 m.

37. Helicopter Ground Taxiway intersection edge fillet radii **should** be no less than 10 m.

38. A helicopter Ground Taxiway **should** extend symmetrically on each side of the centre-line for at least 0.75 times the largest overall width of the helicopters it is intended to serve.

39. **Longitudinal slope.** The longitudinal slope of a helicopter Ground Taxiway **should** be no greater than 3%, to allow for stabilized and safe use of the taxiway by a helicopter.

40. **Transverse slope.** The transverse slopes of a Ground Taxiway **should** be sufficient to prevent the accumulation of water on the surface of the taxiway but **should** be no greater than 2% to promote the most rapid drainage of water from the taxiway.

41. **Surface.** A helicopter Ground Taxiway **should** be static load-bearing and capable of withstanding the traffic of the helicopters the helicopter Ground Taxiway is intended to serve.

42. The surface of a helicopter Ground Taxiway **should** be resistant to the effect of rotor downwash.

43. Shoulders **should** extend symmetrically on each side of the Ground Taxiway and to a width 0.5 x maximum design helicopter overall dimension.

44. The longitudinal slope on a helicopter Ground Taxiway shoulder **should** be no greater than 3%.

45. The transverse slope on a helicopter Ground Taxiway shoulder **should** be no greater than 2%.

46. The shoulder of a helicopter Ground Taxiway **should** be resistant to the effect of rotor downwash.

**Guidance
Material
3531(5)**

Permanent Helicopter Landing Site - Ground Taxiway

47. When a taxiway is intended for use by Air Systems and helicopters, the provisions for taxiways for Air Systems and helicopter Ground Taxiways are to be taken into consideration and the more stringent requirements are to be applied.

Civil Equivalence.

48. This Regulation is in line with ICAO Annex 14 Vol II para 3.1.

**Regulation
3531(6)**

Permanent Helicopter Landing Site - Air Taxiway

3531(6) HoEs and ADH-Facing Organizations **shall** ensure that, where required, a helicopter Air Taxiway is provided to cater for the largest helicopter intended for use at the HLS.

**Acceptable
Means of
Compliance
3531(6)**

Permanent Helicopter Landing Site - Air Taxiway

49. **Location.** Minimum separation distances between helicopter Air Taxiways and other taxiways, objects and helicopter stands **should** be as per Table 2.
50. **Dimension.** The width of a helicopter Air Taxiway **should** be at least two times the largest UCW of the helicopters that the helicopter Air Taxiway is intended to serve.
51. A helicopter Air Taxiway **should** extend symmetrically on each side of the centre-line for a distance at least equal to the largest overall width of the helicopters it is intended to serve.
52. **Slope.** The slopes of the surface of a helicopter Air Taxiway **should not** exceed the slope landing limitation of the helicopters the Air Taxiway is intended to serve.
53. The slopes of a helicopter Air Taxiway **should** be within design helicopter parameters and no more than 7% longitudinally and 10% transversely.
54. **Surface.** The surface of a helicopter Air Taxiway **should**:
- Be rotor down-wash resistant;
 - Be suitable for emergency landing (static load bearing); and
 - Provide ground effect.

**Guidance
Material
3531(6)**

Permanent Helicopter Landing Site - Air Taxiway

Civil Equivalence.

55. This Regulation is in line with ICAO Annex 14 Vol II para 3.1.

**Regulation
3531(7)**

Permanent Helicopter Landing Site - Air Transit Route - Design

3531(7) HoEs and ADH-Facing Organizations **shall** ensure that Air Transit Routes are selected that allow Autorotative / One Engine Inoperative landings whilst minimizing injury or damage to property.

**Acceptable
Means of
Compliance
3531(7)**

Permanent Helicopter Landing Site - Air Transit Route - Design

56. For day operations, the width of the Air Transit Route **should** be no less than 7 times the design helicopter radius.
57. For night operations, the width of the Air Transit Route **should** be no less than 10 times the design helicopter radius.
58. Centre-line direction changes of an Air Transit Route **should** be no more than 120°.
59. Centre-line turn radii of an Air Transit Route **should** be no more than 270 m.

**Guidance
Material
3531(7)**

Permanent Helicopter Landing Site - Air Transit Route - Design

60. Nil.

**Regulation
3531(8)**

Permanent Helicopter Landing Site - Apron - Location

3531(8) HoEs and ADH-Facing Organizations **shall** ensure that HLS Aprons are located such that operations do not adversely impact other Aerodrome users.

**Acceptable
Means of
Compliance
3531(8)**

Permanent Helicopter Landing Site - Apron- Location

61. **Location.** Minimum separation distances between helicopter Aprons, helicopter taxiways, objects and helicopter stands **should** be as per Table 2.
62. **Dimension.** A helicopter stand intended to be used by helicopters turning in a hover **should** be of sufficient size to contain a circle of diameter of at least 1.2D of the largest helicopter the stand is intended to serve.
63. Where a helicopter stand is intended to be used for taxi-through and where the helicopter using the stand is not required to turn, the minimum width of the stand and associated protection area **should** be that of the taxi-route.
64. Where a helicopter stand is intended to be used for turning, the minimum dimension of the stand and protection area **should** be not less than 2D.
65. Where a helicopter stand is intended to be used for turning, it **should** be surrounded by a protection area which extends for a distance of 0.4D from the edge of the helicopter stand.
66. **Slope.** The transverse slopes of an Apron **should** be sufficient to prevent the accumulation of water on the surface of the Apron but **should** be no greater than 2%.
67. **Surface.** A helicopter stand and associated protection area intended to be used for air taxiing **should** provide ground effect.
68. The central zone of a helicopter stand **should** be capable of withstanding the traffic of helicopters it is intended to serve and **should** have a static load-bearing area:
- Of diameter not less than 0.83D of the largest helicopter it is intended to serve; or
 - For a helicopter stand intended to be used for taxi-through, and where the helicopter using the stand is not required to turn, the same width as the helicopter Ground Taxiway.

**Guidance
Material
3531(8)**

Permanent Helicopter Landing Site - Apron- Location

69. For a helicopter stand intended to be used for turning on the ground by wheeled helicopters, the dimension of the helicopter stand, including the dimension of the central zone, may need to be significantly increased.

Civil Equivalence.

70. This Regulation is in line with ICAO Annex 14 Vol II para 3.1.

**Regulation
3531(9)**

Domestic Helicopter Landing Sites - Dimension

- 3531(9) ► **Withdrawn – Incorporated into RA 3536(1): Domestic Helicopter Landing Sites – General Requirements.** ◀

**Acceptable
Means of
Compliance
3531(9)**

Domestic Helicopter Landing Site - Dimension

71. ► **Withdrawn – Incorporated into RA 3536(1): Domestic Helicopter Landing Sites – General Requirements.** ◀

**Guidance
Material
3531(9)**

Domestic Helicopter Landing Site - Dimension

72. ► **Withdrawn – Incorporated into RA 3536(1): Domestic Helicopter Landing Sites – General Requirements.** ◀

Intentionally Blank for Print Pagination

RA 3532 - Helicopter Landing Site - Obstacle Environment

Rationale

The purpose of the Obstacle Limitation Surfaces (OLS) is to define the airspace around Helicopter Landing Sites (HLS) to be maintained free from obstacles so as to permit the intended operations at the HLS to be conducted safely.

Contents

3532(1): Permanent Helicopter Landing Sites - Obstacle Limitation Surfaces (General)

3532(2): Permanent Helicopter Landing Sites - Obstacle Limitation Surfaces for Non-Instrument Approach

3532(3): Permanent Helicopter Landing Sites - Obstacle Limitation Surfaces for Precision or Non-Precision Approach

3532(4): Permanent Helicopter Landing Sites - Obstacle Limitation Surfaces for Visual Approach Slope Indicator

3532(5): ► Withdrawn – Incorporated into RA 3536(1): Domestic Helicopter Landing Sites – General Requirements ◀

3532(6): ► Withdrawn – Incorporated into RA 3536(1): Domestic Helicopter Landing Sites – General Requirements ◀

Regulation 3532(1)

Permanent Helicopter Landing Sites - Obstacle Limitation Surfaces (General)

3532(1) Heads of Establishment (HoE) and Aviation Duty Holder-Facing Organizations (ADH-Facing Organizations) **shall** ensure that the OLS are defined to limit the extent to which objects may project into the airspace.

Acceptable Means of Compliance 3532(1)

Permanent Helicopter Landing Sites - Obstacle Limitation Surfaces (General)

1. The Approach Surface **should**:
 - a. Be an inclined plane or a combination of planes or, when a turn is involved, a complex surface sloping upwards from the end of the Safety Area and centred on a line passing through the centre of the Final Approach and Take Off area (FATO). In the case of an approach surface involving a turn, the surface **should** be a complex surface containing the horizontal normal to its centre-line and the slope of the centre-line **should** be the same as that for a straight approach surface (Figure 1);
 - b. Contain no more than one curved portion. The sum of the radius of arc defining the centre-line of the approach surface and the length of the straight portion originating at the inner edge **should** be no less than 575m with a minimum radius of 270m (Figure 2);
 - c. Have a slope measured in the vertical plane containing the centre-line of the FATO;
 - d. Have limits comprising:
 - (1) An inner edge horizontal and equal in length to the minimum specified width / diameter of the FATO plus the Safety Area, perpendicular to the centre-line of the approach surface and located at the outer edge of the Safety Area;
 - (2) For a non-instrument or non-precision approach: two side edges originating at the ends of the inner edge diverging uniformly at a specified rate from the vertical plane containing the centre-line of the FATO;
 - (3) For a precision approach:

Acceptable Means of Compliance 3532(1)

- (a) Two side edges originating at the ends of the inner edge diverging uniformly at a specified rate from the vertical plane containing the centre-line of the FATO, to a specified height above the FATO,
 - (b) And then diverging uniformly at a specified rate to a specified final width and continuing thereafter at that width for the remaining length of the approach surface.
- (4) An outer edge horizontal and perpendicular to the centre-line of the approach surface and at a specified height above the elevation of the FATO.
- e. Have an elevation of the inner edge the same as the elevation of the FATO at the point on the inner edge that is intersected by the centre-line of the approach surface. For HLS intended to be used by helicopters operated in performance Class 1 and when approved by an appropriate authority, the origin of the inclined plane may be raised directly above the FATO.

Figure 1. Approach Surface

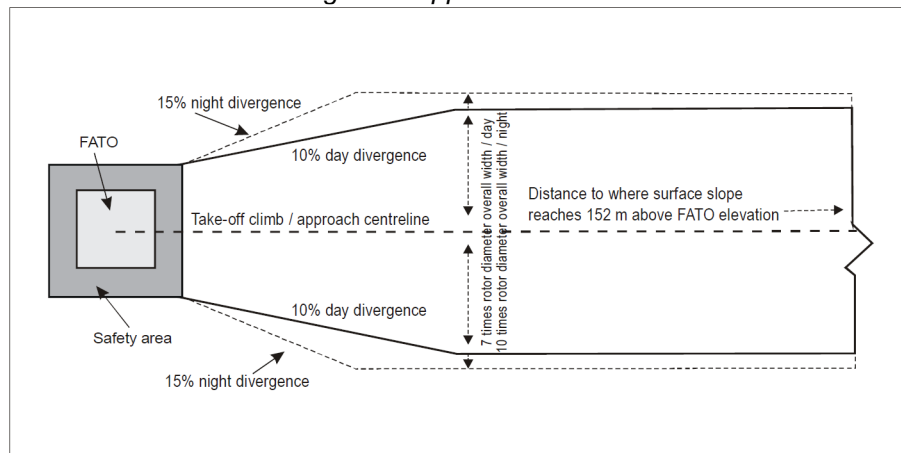
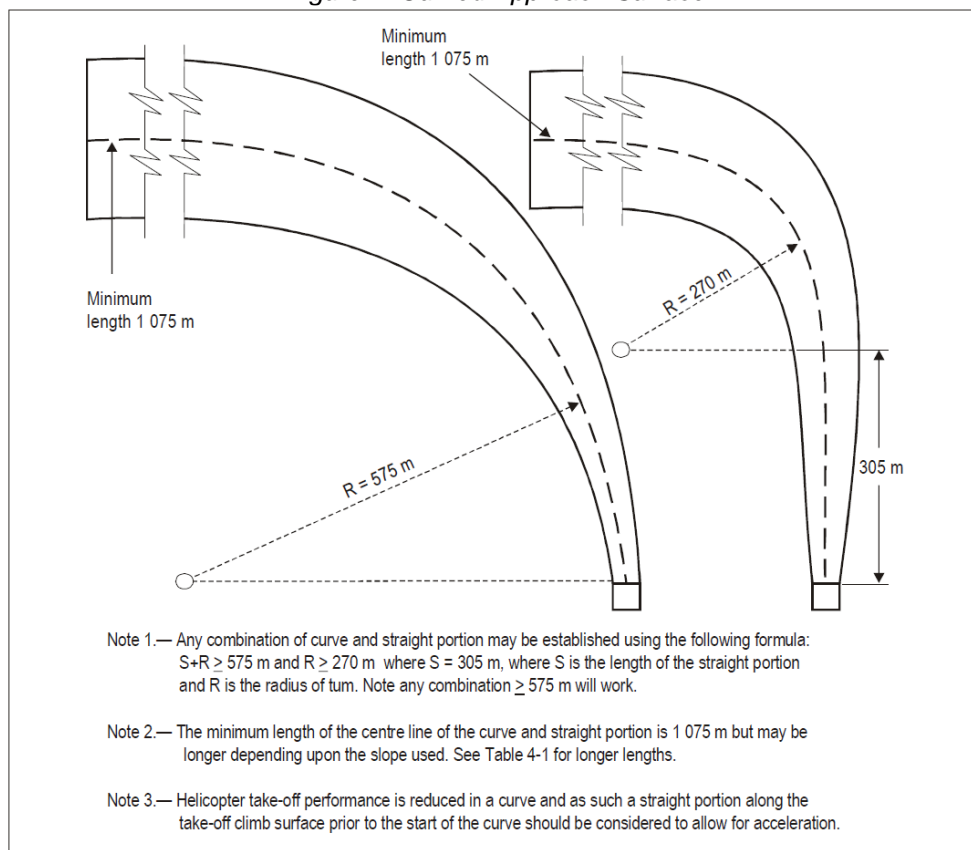

Figure 2. Curved Approach Surface



**Acceptable
Means of
Compliance
3532(1)**

2. The Transitional Surface **should**:
 - a. Be a complex surface along the side of the Safety Area and part of the side of the approach / take-off climb surface, that slopes upwards and outwards to a predetermined height of 45m (150ft.);
 - b. Have limits comprising:
 - (1) A lower edge beginning at a point on the side of the approach / take-off climb surface at a specified height above the lower edge extending down the side of the approach / take-off climb surface to the inner edge of the approach / take-off climb surface and from there along the length of the side of the Safety Area parallel to the centre-line of the FATO;
 - (2) An upper edge located at a specified height above the lower edge;
 - c. Have an elevation of a point on the lower edge that:
 - (1) Along the side of the approach / take-off climb surface is equal to the elevation of the approach / take-off climb surface at that point; and
 - (2) Along the Safety Area is equal to the elevation of the inner edge of the approach / take-off climb surface;
 - d. Be measured in a vertical plane at right angles to the centre-line of the FATO.
3. The Take-Off Climb Surface **should**:
 - a. Be an inclined plane, a combination of planes or, when a turn is involved, a complex surface sloping upwards from the end of the Safety Area and centred on a line passing through the centre of the FATO. In the case of a take-off climb surface involving a turn, the surface **should** be a complex surface containing the horizontal normal to its centre-line and the slope of the centre-line **should** be the same as that for a straight take-off climb surface (Figure 3);
 - b. Contain no more than one curved portion. The sum of the radius of arc defining the centre-line of the approach surface and the length of the straight portion originating at the inner edge **should** be no less than 575 m with a minimum radius of 270 m;
 - c. Have a slope measured in the vertical plane containing the centre-line of the surface;
 - d. Have limits comprising:
 - (1) An inner edge horizontal and equal in length to the minimum specified width / diameter of the FATO plus the Safety Area, perpendicular to the centre-line of the take-off climb surface and located at the outer edge of the Safety Area;
 - (2) Two side edges originating at the ends of the inner edge and diverging uniformly at a specified rate from the vertical plane containing the centre-line of the FATO; and
 - (3) An outer edge horizontal and perpendicular to the centre-line of the take-off climb surface and at a specified height of 152 m (500ft.) above the elevation of the FATO.
 - (4) An elevation of the inner edge equal to the elevation of the FATO at the point on the inner edge that is intersected by the centre-line of the take-off climb surface. For HLS intended to be used by helicopters operated in performance Class 1 and when approved by an appropriate authority, the origin of the inclined plane may be raised directly above the FATO;
 - e. Where a clearway is provided, have an elevation of the inner edge of the take-off climb surface located at the outer edge of the clearway at the highest point on the ground based on the centre-line of the clearway;

Acceptable
Means of
Compliance
3532(1)

Figure 3. Take off climb surface

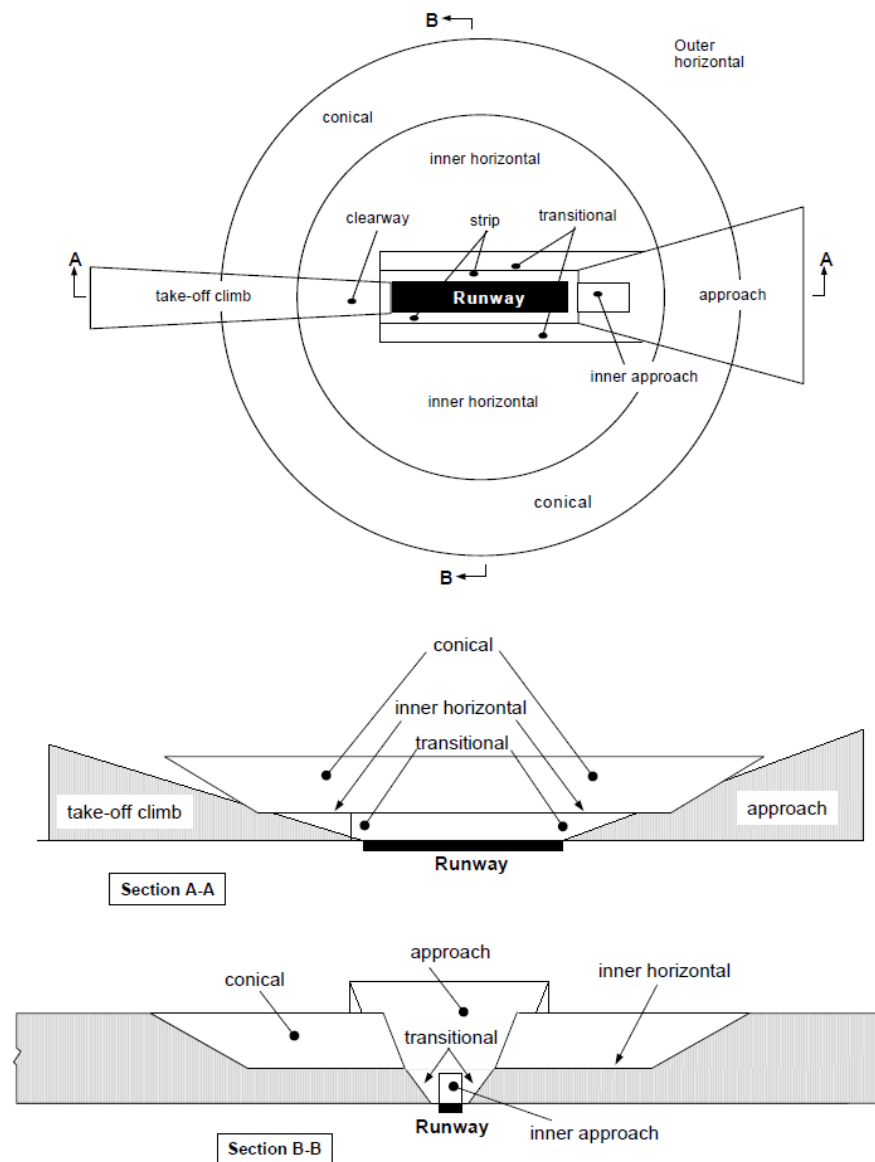

4. Surface level HLS **should** have at least two approach and take-off surfaces to avoid downwind conditions, minimize crosswind conditions and permit for a balked landing.
5. Visual Approach Slope Indicator Obstacle Protection Surface **should**:
 - a. Be an inclined plane sloping upwards from the end of the Safety Area and centred on a line through the FATO centre (Figure 4);
 - b. Have an inner edge horizontal and equal in length to the minimum specified width of the FATO plus the Safety Area, perpendicular to the centre-line of the approach surface and located at the outer edge of the Safety Area;
 - c. Have two side edges originating at the ends of the inner edge diverging uniformly at a specified rate from the vertical plane containing the centre-line of the FATO;
 - d. Have an outer edge horizontal and perpendicular to the centre-line of the approach surface and at a specified height above the elevation of the FATO; and
 - e. Have a slope measured in a vertical plane at right angles to the centre-line of the FATO.

**Acceptable
Means of
Compliance
3532(1)**

Figure 4 Visual Approach Slope Indicator Obstacle Protection Surface

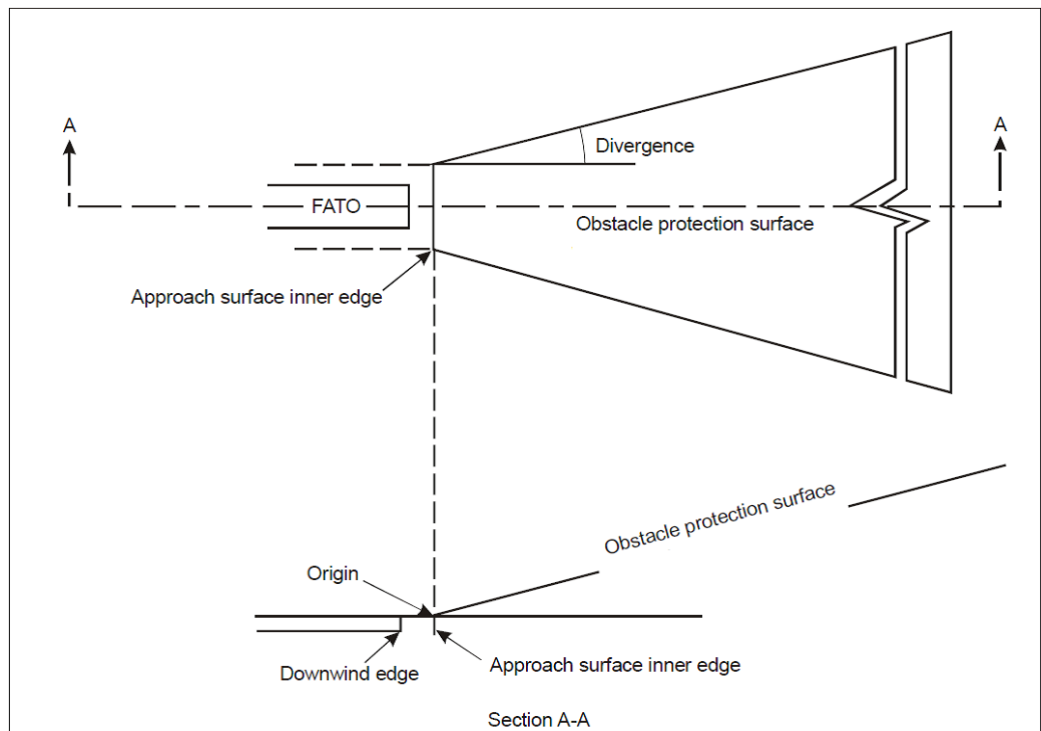

6. Where no transitional surface is provided, a protected side slope **should** be provided rising at 45° from the edge of the Safety Area to a distance of 10 m, whose surface **should not** be penetrated by obstacles, except that when obstacles are located to one side of the FATO only, they may be permitted to penetrate the side slope surface.

7. No fixed object **should** be permitted above the plane of the FATO on a Safety Area, except for frangible objects, which, because of their function, **need to** be located on the area. No mobile object **should** be permitted on a Safety Area during helicopter operations.

a. Objects whose function requires them to be located on the Safety Area **should not**:

- (1) If located at a distance of less than $0.75D^1$ from the centre of the FATO, penetrate a plane at a height of 5 cm above the plane of the FATO; and
- (2) If located at a distance of $0.75D$ or more from the centre of the FATO, penetrate a plane originating at a height of 25 cm above the plane of the FATO and sloping upwards and outwards at a gradient of 5%.

**Guidance
Material
3532(1)**

Permanent Helicopter Landing Sites - Obstacle Limitation Surfaces (General)

8. Helicopter take-off performance is reduced in a curve and as such a straight portion along the take-off climb surface prior to the start of the curve allows for acceleration.

9. For HLS intended to be used by helicopters operated in performance Class 2 and 3 it is good practice for the departure paths to be selected so as to permit safe forced landings or one-engine-inoperative landings such that, as a minimum requirement, injury to persons on the ground or water or damage to property are minimized. The most critical helicopter type for which the HLS is intended and the ambient conditions may be factors in determining the suitability of such areas.

¹ Where D is the largest overall dimension of the helicopter using the HLS.

**Guidance
Material
3532(1)**

10. To support operations with only one approach and take-off climb surface, an aeronautical study may be undertaken by an appropriate authority considering as a minimum, the following factors:
- The area / terrain over which the flight is being conducted;
 - The obstacle environment surrounding the HLS;
 - The performance and operating limitations of helicopters intending to use the HLS; and
 - The local meteorological conditions including the prevailing winds

Civil Equivalence.

11. This Regulation is in line with ICAO Annex 14 Vol II Chapter 4.

**Regulation
3532(2)****Permanent Helicopter Landing Sites - Obstacle Limitation Surfaces for Non-Instrument Approach**

3532(2) HoEs and ADH-Facing Organizations **shall** ensure that OLS are established for a FATO at HLS with non-instrument approach procedures.

**Acceptable
Means of
Compliance
3532(2)****Permanent Helicopter Landing Sites - Obstacle Limitation Surfaces for Non-Instrument Approach**

12. Obstacle limitation surfaces indicated in Table 1 **should** be established for a FATO at HLS with non-instrument approach procedures.

Table 1. Dimensions and slopes of obstacle limitation surfaces for all non-instrument FATOs

| Surface and Dimensions | Slope Design Categories | | |
|--|--|----------------------|----------------------|
| | A | B | C |
| Approach and Take-Off Climb Surface: | | | |
| Length of inner edge | Width of Safety Area | Width of Safety Area | Width of Safety Area |
| Location of inner edge | Safety Area boundary (Clearway boundary if provided) | Safety Area boundary | Safety Area boundary |
| Divergence: (1st and 2nd section) | | | |
| Day use only | 10% | 10% | 10% |
| Night use | 15% | 15% | 15% |
| First Section: | | | |
| Length | 3386 m | 245 m | 1220 m |
| Slope | 4.5% | 8% | 12.5% |
| | (1:22.2) | (1:12.5) | (1:8) |
| Outer Width | (b) | N/A | (b) |

| | | | | |
|---|---|--------------|-----------------|--------------|
| Acceptable Means of Compliance 3532(2) | Second Section: | | | |
| | Length | N/A | 830 m | N/A |
| | Slope | N/A | 16% (1:6.25) | N/A |
| | Outer Width | N/A | (b) | N/A |
| | Total length from inner edge (a) | 3386 m | 1075 m | 1220 m |
| | Transitional Surface: (FATOs with a PinS approach procedure with a Visual Segment Surface (VSS)) | | | |
| | Slope | 50% (1:2) | 50% (1:2) | 50% (1:2) |
| | Height | 45 m | 45 m | 45 m |

| | |
|----------------------------------|--|
| Guidance Material 3532(2) | <p>Permanent Helicopter Landing Sites - Obstacle Limitation Surfaces for Non-Instrument Approach</p> <p>Civil Equivalence.</p> <p>13. This Regulation is in line with ICAO Annex 14 Vol II para 5.3.</p> |
|----------------------------------|--|

| | |
|---------------------------|--|
| Regulation 3532(3) | <p>Permanent Helicopter Landing Sites - Obstacle Limitation Surfaces for Precision or Non-Precision Approach</p> <p>3532(3) HoEs and ADH-Facing Organizations shall ensure that for an instrument FATO with a Precision or Non-Precision Approach the following OLS are established; Take-Off Climb Surface, Approach Surface, and Transitional Surface.</p> |
|---------------------------|--|

| Acceptable Means of Compliance 3532(3) | <p>Permanent Helicopter Landing Sites - Obstacle Limitation Surfaces for Precision or Non-Precision Approach</p> <p>14. The slopes of the obstacle limitation surfaces should be less than, and their other dimensions should be greater than those specified in Table 2 for precision FATO and Table 3 for non-precision FATO.</p> <p style="text-align: center;"><i>Table 2. Dimensions and slopes of obstacle limitation surfaces: Instrument (Precision) FATO</i></p> <table border="1" style="width: 100%; border-collapse: collapse;"> <thead> <tr> <th rowspan="2">Surface and dimensions</th> <th colspan="4">3° approach Height above FATO</th> <th colspan="4">6° approach Height above FATO</th> </tr> <tr> <th>90 m (300 ft)</th> <th>60 m (200 ft)</th> <th>45 m (150 ft)</th> <th>30 m (100 ft)</th> <th>90 m (300 ft)</th> <th>60 m (200 ft)</th> <th>45 m (150 ft)</th> <th>30 m (100 ft)</th> </tr> </thead> <tbody> <tr> <td>Approach Surface</td> <td colspan="8"></td> </tr> <tr> <td>Length of inner edge</td> <td colspan="8" style="text-align: center;">90 m</td> </tr> <tr> <td>Distance from end of FATO</td> <td colspan="8" style="text-align: center;">60 m</td> </tr> </tbody> </table> | Surface and dimensions | 3° approach Height above FATO | | | | 6° approach Height above FATO | | | | 90 m (300 ft) | 60 m (200 ft) | 45 m (150 ft) | 30 m (100 ft) | 90 m (300 ft) | 60 m (200 ft) | 45 m (150 ft) | 30 m (100 ft) | Approach Surface | | | | | | | | | Length of inner edge | 90 m | | | | | | | | Distance from end of FATO | 60 m | | | | | | | |
|---|---|------------------------|----------------------------------|------------------|----------------------------------|------------------|----------------------------------|------------------|--|--|------------------|------------------|------------------|------------------|------------------|------------------|------------------|------------------|-------------------------|--|--|--|--|--|--|--|--|----------------------|------|--|--|--|--|--|--|--|---------------------------|------|--|--|--|--|--|--|--|
| Surface and dimensions | 3° approach Height above FATO | | | | 6° approach Height above FATO | | | | | | | | | | | | | | | | | | | | | | | | | | | | | | | | | | | | | | | | |
| | 90 m (300 ft) | 60 m (200 ft) | 45 m (150 ft) | 30 m (100 ft) | 90 m (300 ft) | 60 m (200 ft) | 45 m (150 ft) | 30 m (100 ft) | | | | | | | | | | | | | | | | | | | | | | | | | | | | | | | | | | | | | |
| Approach Surface | | | | | | | | | | | | | | | | | | | | | | | | | | | | | | | | | | | | | | | | | | | | | |
| Length of inner edge | 90 m | | | | | | | | | | | | | | | | | | | | | | | | | | | | | | | | | | | | | | | | | | | | |
| Distance from end of FATO | 60 m | | | | | | | | | | | | | | | | | | | | | | | | | | | | | | | | | | | | | | | | | | | | |

**Acceptable
Means of
Compliance
3532(3)**

| | | | | | | | | |
|---|-----------------------------|--------|--------|--------|-----------------|--------|--------|--------|
| Divergence each side to height above FATO | 25% | | | | | | | |
| Distance to height above FATO | 1745 m | 1163 m | 872 m | 581 m | 870 m | 580 m | 435 m | 290 m |
| Width at height above FATO | 962 m | 671 m | 526 m | 380 m | 521 m | 380 m | 435 m | 290 m |
| Divergence to parallel section | 15% | | | | | | | |
| Distance to parallel section | 2793 m | 3763 m | 4246 m | 4733 m | 4250 m | 4733 m | 4975 m | 5217 m |
| Width of parallel section | 1 800 m | | | | | | | |
| Distance to outer edge | 5462 m | 5074 m | 4882 m | 4686 m | 3380 m | 3187 m | 3090 m | 2993 m |
| Width at outer edge | 1 800 m | | | | | | | |
| Slope of first section | 2.5% (1:40) | | | | 5% (1:20) | | | |
| Length of first section | 3000 m | | | | 1500 m | | | |
| Slope of second section | 3% (1:33.3) | | | | 6% (1:16.66) | | | |
| Length of second section | 10000 m | | | | 8500 m | | | |
| Total length of surface | 13000 m | | | | 10000 m | | | |
| Take-Off Climb Surface | | | | | | | | |
| Length of inner edge | 90 m | | | | | | | |
| Location of inner edge | Boundary of end of Clearway | | | | | | | |
| First section divergence | 30% | | | | | | | |
| First section length | 2850 m | | | | | | | |
| First section outer width | 1800 m | | | | | | | |
| First section maximum slope | 3.5% | | | | | | | |
| Second section divergence | Parallel | | | | | | | |
| Second section length | 1510 m | | | | | | | |
| Second section outer width | 1800 m | | | | | | | |
| Second section maximum slope | 3.5% | | | | | | | |
| Third section divergence | Parallel | | | | | | | |
| Third section length | 7640 m | | | | | | | |
| Third section outer width | 1800 m | | | | | | | |
| Third section maximum slope | 2% | | | | | | | |
| Transitional | | | | | | | | |
| Slope | 14.3% | 14.3% | 14.3% | 14.3% | 14.3% | 14.3% | 14.3% | 14.3% |
| Height | 45 m | 45 m | 45 m | 45 m | 45 m | 45 m | 45 m | 45 m |

**Acceptable
Means of
Compliance
3532(3)**

Table 3 Dimensions and slopes of obstacle limitation surfaces: Instrument (non-precision) FATO

| Surfaces and Dimensions | |
|-------------------------------|--------------------------------|
| Approach Surface | |
| Width of inner edge | Width of Safety Area |
| Location of inner edge | Boundary |
| Frist Section | |
| Divergence | 16% |
| Length | 200 m |
| Outer width | 890 m |
| Slope (maximum) | 3.33% |
| Second Section | |
| Divergence | - |
| Length | - |
| Outer width | - |
| Third Section | |
| Divergence | - |
| Length | - |
| Outer width | - |
| Slope (maximum) | - |
| Transitional | |
| Slope | 20% |
| Height | 45 m |
| Take-Off Climb Surface | |
| Length of inner edge | 90 m |
| Location of inner edge | Boundary of end of Clearway |
| First Section | |
| Divergence | 30% |
| Length | 2850 m |
| Outer width | 1800 m |
| Maximum slope | 3.5% |
| Second Section | |
| Divergence | Parallel |
| Length | 1510 m |
| Outer width | 1800 m |

**Acceptable
Means of
Compliance
3532(3)**

| | |
|----------------------|----------|
| Maximum slope | 3.5% |
| Third Section | |
| Divergence | Parallel |
| Length | 7640 m |
| Outer width | 1800 m |
| Maximum slope | 2% |

**Guidance
Material
3532(3)**

Permanent Helicopter Landing Sites - Obstacle Limitation Surfaces for Precision or Non-Precision Approach

Civil Equivalence.

15. This Regulation is in line with ICAO Annex 14 Vol II para 4.2.

**Regulation
3532(4)**

Permanent Helicopter Landing Sites - Obstacle Limitation Surfaces for Visual Approach Slope Indicator

3532(4) HoEs and ADH-Facing Organizations **shall** ensure that an OLS is established for FATOs where visual approach slope indicators are utilized.

**Acceptable
Means of
Compliance
3532(4)**

Permanent Helicopter Landing Sites - Obstacle Limitation Surfaces for Visual Approach Slope Indicator

16. The characteristics of the OLS, ie origin, divergence, length and slope, **should** correspond to those specified in Table 4.

Table 4. Dimensions and slopes of the obstacle protection surface

| Surface and Dimensions | FATO | |
|---|----------------------|------------------------|
| Length of inner edge | Width of Safety Area | |
| Distance from end of FATO | 3 m minimum | |
| Divergence | 10% | |
| Total length | 2500 m | |
| Slope | PAPI ² | A ^a – 0.57° |
| | HAPI ³ | A ^b – 0.65° |
| | APAPI ⁴ | A ^a – 0.9° |
| a. As indicated in ICAO Annex 14, Volume 1, Figure 5-20. b. The angle of the upper boundary of the 'below slope' signal. | | |

17. New objects or extensions of existing objects **should not** be permitted above the obstacle protection surface except when, in the opinion of the appropriate authority and subject to a Safety Assessment, the new object or extension would be shielded by an existing immovable object.

18. Existing objects above the obstacle protection surface **should** be removed except when, in the opinion of the appropriate authority and subject to a Safety

² Precision Approach Path Indicator.

³ Helicopter Approach Path Indicator.

⁴ Abbreviated Precision Approach Path Indicator.

**Acceptable
Means of
Compliance
3532(4)**

Assessment, the object is shielded by an existing immovable object, or after aeronautical study it is determined that the object would not adversely affect the Safety of operations of helicopters.

19. Where an aeronautical study indicates that an existing object extending above an obstacle protection surface could adversely affect the Safety of operations of helicopters, one or more of the following measures **should** be taken:

- a. Suitably raise the approach slope of the system;
- b. Reduce the azimuth spread of the system so that the object is outside the confines of the beam;
- c. Displace the axis of the system and its associated obstacle protection surface by no more than 5°;
- d. Suitably displace the FATO; or
- e. Install a visual alignment guidance system specified in RA 3535⁵.

**Guidance
Material
3532(4)**

Permanent Helicopter Landing Sites - Obstacle Limitation Surfaces for Visual Approach Slope Indicator

Civil Equivalence.

20. This Regulation is in line with ICAO Annex 14 Vol II para 4.2.

**Regulation
3532(5)**

Domestic Helicopter Landing Sites - Obstacles

3532(5) ► **Withdrawn – Incorporated into RA 3536(1): Domestic Helicopter Landing Sites – General Requirements.** ◀

**Acceptable
Means of
Compliance
3532(5)**

Domestic Helicopter Landing Sites - Obstacles

21. ► **Withdrawn – Incorporated into RA 3536(1): Domestic Helicopter Landing Sites – General Requirements.** ◀

**Guidance
Material
3532(5)**

Domestic Helicopter Landing Sites - Obstacles

22. ► **Withdrawn – Incorporated into RA 3536(1): Domestic Helicopter Landing Sites – General Requirements.** ◀

**Regulation
3532(6)**

Domestic Helicopter Landing Sites - Approaches

3532(6) ► **Withdrawn – Incorporated into RA 3536(1): Domestic Helicopter Landing Sites – General Requirements.** ◀

**Acceptable
Means of
Compliance
3532(6)**

Domestic Helicopter Landing Sites - Approaches

23. ► **Withdrawn – Incorporated into RA 3536(1): Domestic Helicopter Landing Sites – General Requirements.** ◀

**Guidance
Material
3532(6)**

Domestic Helicopter Landing Sites - Approaches

24. ► **Withdrawn – Incorporated into RA 3536(1): Domestic Helicopter Landing Sites – General Requirements.** ◀

⁵ ► Refer to ◀ RA 3535 – Helicopter Landing Sites - ► Lighting. ◀

Intentionally Blank for Print Pagination

RA 3533 - Helicopter Landing Site - Indicators and Signalling Devices

Rationale

At Helicopter Landing Sites (HLS), and in particular, where landing information is not available through radio communications, indicators and signalling devices are important visual aids ►to◄ improving safety.

Contents

3533(1): Helicopter Landing Sites - Wind Direction Indicator
3533(2): Permanent Helicopter Landing Sites - Aerodrome Identification

Regulation 3533(1)

Helicopter Landing Sites - Wind Direction Indicator

3533(1) Heads of Establishment (HoE) and Aviation Duty Holder-Facing Organizations (ADH-Facing Organizations) **shall** ensure that permanent and domestic HLS are equipped with at least one wind direction indicator.

Acceptable Means of Compliance 3533(1)

Helicopter Landing Sites - Wind Direction Indicator

1. A wind direction indicator **should** be located to indicate the wind conditions over the Final Approach and Take Off area (FATO) and Touchdown and Lift Off area (TLOF) and in such a way as to be free from the effects of airflow disturbances caused by nearby objects or rotor downwash. It **should** be visible from a helicopter in flight, in a hover or on the movement area.
2. Where a TLOF and/or FATO may be subject to a disturbed airflow, then additional wind direction indicators located close to the area **should** be provided to indicate the surface wind on the area.
3. Wind direction indicators **should**:
 - a. Be in the form of a truncated cone made of fabric;
 - b. Have a length of not less than 2.4 m a diameter at the larger end of not less than 0.6 m and a diameter at the smaller end of not less than 0.3 m;
 - c. Be constructed so that it gives a clear indication of the direction of the surface wind and a general indication of the wind speed; and
 - d. Be of a colour or colours (preferably orange or white) as to make the wind direction indicator clearly visible and understandable from a height of at least 200 m.
4. Wind direction indicators at a HLS intended for use at night **should** be illuminated.

Guidance Material 3533(1)

Helicopter Landing Sites - Wind Direction Indicator

5. Where practicable, a single colour may be used. Where a combination of two colours is required to give adequate conspicuity against changing backgrounds, they may preferably be orange and white, red and white, or black and white, and ►need to◄ be arranged in five alternate bands, the first and last bands being the darker colour.

Civil Equivalence.

6. This regulation is in line with International Civil Aviation Organization (ICAO) Annex 14 Vol II para 5.1.

Regulation 3533(2)

Permanent Helicopter Landing Sites - Aerodrome Identification

3533(2) HoEs and ADH-Facing Organizations **shall** ensure that permanent HLS are readily identifiable from the air.

**Acceptable
Means of
Compliance
3533(2)****Permanent Helicopter Landing Sites - Aerodrome Identification**

7. A HLS name marking **should** be provided at a HLS where there is insufficient alternative means of visual identification.
8. The markings, where provided, **should**:
 - a. Be visible, at all angles above the horizontal. Where an obstacle sector exists, the marking **should** be located on the obstacle side of the H identification marking;
 - b. Consist of the name or alphanumeric designator of the base as used in the Radio/Telephony communications;
 - c. Be not less than 3 m in height and the colour of the markings **should** contrast with the background; and
 - d. When intended for use at night or in poor visibility, be illuminated, either internally or externally.

**Guidance
Material
3533(2)****Permanent Helicopter Landing Sites - Aerodrome Identification**

9. For Non-runway type FATOs, the minimum height may be reduced to 1.5 m.
- Civil Equivalence.**
10. This regulation is in line with ICAO Annex 14 Vol II para 5.2.

RA 3534 - Helicopter Landing Site - Markings

Rationale

A Helicopter Landing Site (HLS) can be a confusing place to operate within. If clear indications are not provided to direct Air Systems to the correct areas, or to warn personnel of manoeuvring areas, there is a higher risk of incident. To enhance the safe movement of Air Systems at a HLS, markings are defined to provide clear and consistent information and guidance to the operating community.

Contents

- 3534(1): Helicopter Landing Site Identification Markings**
- 3534(2): Permanent Helicopter Landing Site - Final Approach and Take Off Dimensions and Markings**
- 3534(3): Permanent Helicopter Landing Site - Aiming Point Markings**
- 3534(4): Permanent Helicopter Landing Site - Touchdown and Lift Off Markings**
- 3534(5): Permanent Helicopter Landing Site - Touchdown / Positioning Markings**
- 3534(6): Permanent Helicopter Landing Site - Air Taxiway Markers and Markings**
- 3534(7): Permanent Helicopter Landing Site - Air Taxi Route Markers**
- 3534(8): Permanent Helicopter Landing Site - Helicopter Stand Markings**
- 3534(9): Permanent Helicopter Landing Site - Flight Path Alignment Guidance Marking**

Regulation 3534(1)

Helicopter Landing Site Identification Markings

3534(1) Heads of Establishment (HoE) and Aviation Duty Holder (ADH) Facing organizations **shall** ensure that HLS identification markings are provided at Permanent HLS.

Acceptable Means of Compliance 3534(1)

Helicopter Landing Site Identification Markings

1. Permanent HLS Identification Markings **should**:
 - a. For all Final Approach and Take Off (FATOs) except runway type FATOs:
 - (1) Be located at or near the centre of the FATO;
 - (2) Be located at the centre of the aiming point marking (except for a hospital HLS) where the FATO does not contain a Touchdown and Lift Off (TLOF) but is marked with an aiming point; and
 - (3) Be located at the centre of the TLOF where the FATO contains a TLOF.
 - b. For runway type FATOs, be located in the FATO and when used in conjunction with FATO designation markings, **should** be displayed at each end of the FATO as shown in Figure 1.
 - c. Consist of a letter H, white in colour. The dimensions of the H marking **should** be no less than as shown in Figure 1 and where the marking is used for a runway-type FATO, its dimensions **should** be increased by a factor of 3 as shown in Figure 1; and
 - d. Be oriented with the cross arm of the H at right angles to the preferred final approach direction.

**Acceptable
Means of
Compliance
3534(1)**

2. A Domestic HLS at a hospital **should** consist of a letter H, red in colour, on a white cross made of squares adjacent to each of the sides of a square containing the H.

Figure 1. HLS Identification Markings



**Guidance
Material
3534(1)**

Helicopter Landing Site Identification Markings

Civil Equivalence.

3. This regulation is in line with International Civil Aviation Organization (ICAO) Annex 14 Vol II para 5.2.

**Regulation
3534(2)**

Permanent Helicopter Landing Site - Final Approach and Take Off Dimensions and Markings

- 3534(2) HoEs and ADH Facing organizations **shall** ensure that, where the extent of the FATO is not self-evident, FATO markings are provided.

**Acceptable
Means of
Compliance
3534(2)**

Permanent Helicopter Landing Site - Final Approach and Take Off Dimensions and Markings

4. FATO dimension markings **should**:
- Be located within the FATO and so arranged as to be readable from the preferred final approach direction;
 - Be marked on a FATO intended for:
 - Use by helicopters operated in performance Class 1; or
 - Use by helicopters operated in performance Class 2 or 3 is less than 1D¹.
 - Be rounded to the nearest metre or foot.
 - Rectangular FATOs **should** have both the length and width of the FATO relative to the preferred approach direction indicated;
 - For all FATOs except runway type FATOs, have a colour contrasting with the background and **should** be in the form and proportion shown in Figure 2 for a FATO with a dimension of more than 30m. For a FATO with a dimension between 15m to 30m the height of the numbers of the marking **should** be a minimum of 90cm, and for a FATO with a dimension of less than 15m the height of the numbers of the marking **should** be a minimum of 60cm, each with a proportional reduction in width and thickness;
 - For runway type FATOs, have a colour contrasting with the background and **should** be in the form and proportion shown in Figure 2.

¹ Where D is the largest overall dimension of the helicopter using the HLS.

Acceptable
Means of
Compliance
3534(2)

Figure 2. Character Form and Proportion

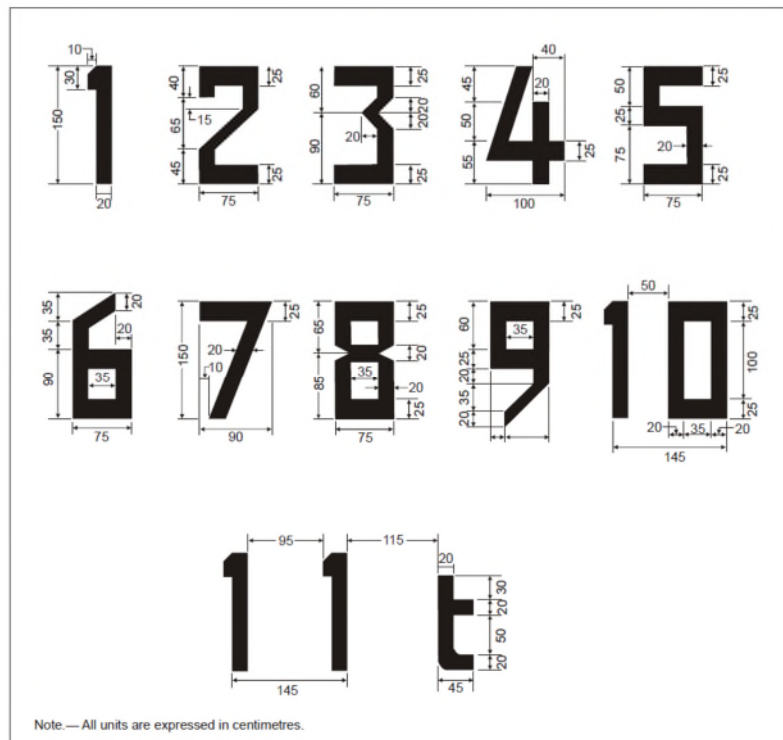

5. FATO perimeter markings or markers **should**:
- a. Be located on the edge of the FATO;
 - b. For runway type FATOs:
 - (1) Be defined with markings or markers spaced at equal intervals of not more than 50m with at least three markings or markers on each side including a marking or marker at each corner;
 - (2) Where markers are used, be of colours that contrast effectively against the operating background and have dimensional characteristics as shown in Figure 3; and
 - (3) Where markings are used, be white in colour and be a rectangular stripe with a length of 9m or one-fifth of the side of the FATO which it defines and a width of 1m;
 - c. For all FATOs except runway type FATOs:
 - (1) Be 30cm in width, 1.5m in length, and with end-to-end spacing of not less than 1.5m and not more than 2m. The corners of a square or rectangular FATO **should** be defined;
 - (2) Be flush in-ground markers for an unpaved FATO.
 - (3) Have a dashed line for a paved FATO.
 - (4) Be white in colour (both markings and flush in-ground markers).

**Acceptable
Means of
Compliance
3534(2)**

Figure 3. Marker Colouring and Dimension

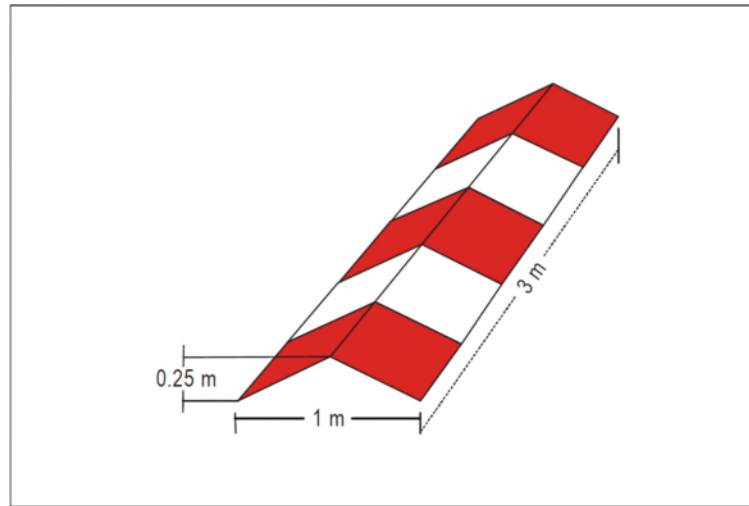

6. Where it is necessary to designate the runway type FATO to the pilot, a FATO designation marking **should**:
- a. Be located at the beginning of the FATO as shown in Figure 1;
 - b. Consist of a two-digit number. The two-digit number **should**:
 - (1) Be the whole number nearest the one-tenth of the magnetic North when viewed from the direction of approach;
 - (2) When the above rule would give a single digit number, it **should** be preceded by a zero; and
 - (3) Be supplemented by HLS identification marking as per RA 3534(1).

**Guidance
Material
3534(2)**

Permanent Helicopter Landing Site - Final Approach and Take Off Dimensions and Markings

7. FATO perimeter marking or markers must be provided at a surface-level heliport where the extent of the FATO is not self-evident. FATO perimeter markers may be a single colour, orange or red, or two contrasting colours, orange and white or, alternatively, red and white may be used except where such colours would merge with the background.

Civil Equivalence.

8. This regulation is in line with ICAO Annex 14 Vol II para 5.2.

**Regulation
3534(3)**

Permanent Helicopter Landing Site - Aiming Point Markings

3534(3) HoEs and ADH Facing organizations **shall** ensure that an aiming point is provided at a Permanent HLS where it is necessary for a pilot to make an approach to a point above a FATO before proceeding to a TLOF.

**Acceptable
Means of
Compliance
3534(3)**

Permanent Helicopter Landing Site - Aiming Point Markings

9. Aiming point markings **should**:
- a. For runway-type FATOs, be located within the FATO;
 - b. For all FATOs except runway type FATOs, be located at the centre of the FATO.
 - c. Be an equilateral triangle with the bisector of one of the angles aligned with the preferred approach direction; and
 - d. Consist of continuous white lines, and the dimensions of the marking **should** conform to those shown in Figure 4.

Acceptable Means of Compliance 3534(3)

Figure 4. Aiming Point Marking Dimensions

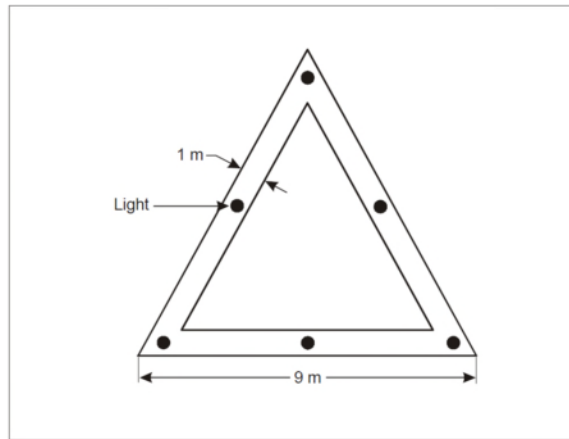

Guidance Material 3534(3)

Permanent Helicopter Landing Site - Aiming Point Markings
Civil Equivalence.

10. This regulation is in line with ICAO Annex 14 Vol II para 5.2.

Regulation 3534(4)

Permanent Helicopter Landing Site - Touchdown and Lift Off Markings

3534(4) HoEs and ADH Facing organizations **shall** ensure that a TLOF perimeter marking is displayed if the perimeter of the TLOF is not self-evident.

Acceptable Means of Compliance 3534(4)

Permanent Helicopter Landing Site - Touchdown and Lift Off Markings

11. TLOF perimeter markings **should**:

- a. Be located along the edge of the TLOF;
- b. Consist of a continuous white line with a width of at least 30cm; and
- c. Be provided for each TLOF collocated with a helicopter stand.

Guidance Material 3534(4)

Permanent Helicopter Landing Site - Touchdown and Lift Off Markings

12. The values in Figure 5 may be used to determine TLOF perimeter markings to cater for increased conspicuity for large TLOF.

Civil Equivalence.

13. This regulation is in line with ICAO Annex 14 Vol II para 5.2.

Figure 5. TLOF Perimeter Markings

| TLOF size in metres | Line thickness in metres | |
|---------------------|--------------------------|------|
| | C | D |
| E | | |
| 13-18 | 1.0 | 0.4 |
| 18-24 | 1.3 | 0.6 |
| 24-30 | 1.5 | 0.6 |
| 30-45 | 2.0 | 0.75 |

A = 0.6 E (maximum 20m)
 B = 0.5 A

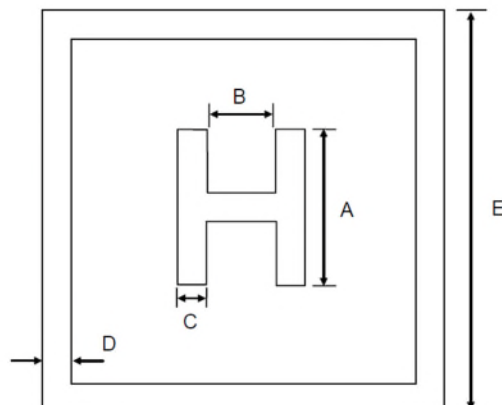

**Regulation
3534(5)**

Permanent Helicopter Landing Site - Touchdown / Positioning Markings

3534(5) HoEs and ADH Facing organizations **shall** ensure that a touchdown / positioning marking is provided where it is necessary for a helicopter to touch down and/or be accurately positioned by the pilot. A touchdown/positioning marking **shall** be provided on a helicopter stand designed for turning.

**Acceptable
Means of
Compliance
3534(5)**

Permanent Helicopter Landing Site - Touchdown / Positioning Markings

14. Touchdown / positioning markings **should**:
- a. Be located so that when the pilot's seat is over the marking, the whole of the undercarriage will be within the TLOF and all parts of the helicopter will be clear of any obstacle by a safe margin;
 - b. Be located in the centre of the TLOF;
 - c. For a stand designed for hover turning, be located at the centre of the central zone (RA 3531²);
 - d. Be a yellow circle and have a line width of at least 0.5m; and
 - e. Have an inner diameter of 0.5D of the largest helicopter the TLOF and/or the helicopter stand is intended to serve.

**Guidance
Material
3534(5)**

Permanent Helicopter Landing Site - Touchdown / Positioning Markings

15. The centre of the touchdown / positioning marking may be offset away from the centre of the TLOF where an aeronautical study indicates such offsetting to be necessary and providing that a marking so offset would not adversely affect safety.

Civil Equivalence.

16. This regulation is in line with ICAO Annex 14 Vol II para 5.2.

**Regulation
3534(6)**

Permanent Helicopter Landing Site - Air Taxiway Markers and Markings

3534(6) HoEs and ADH Facing organizations **shall** ensure that the centre-line of a helicopter Air Taxiway or, if not self-evident, the edges of a helicopter Air Taxiway are identified with markers or markings.

**Acceptable
Means of
Compliance
3534(6)**

Permanent Helicopter Landing Site - Air Taxiway Markers and Markings

17. Air Taxiway centre-line markings **should**:
- a. Be located along the centre-line of the helicopter Air Taxiway; and
 - b. On a paved surface, be a continuous yellow line 15cm in width.
18. Air Taxiway centre-line markers **should**:
- a. Be flush in-ground type markers and located along the centre-line of the helicopter Air Taxiway; and
 - b. When on an unpaved surface, be flush in-ground, 15cm wide and approximately 1.5m in length yellow markers, spaced at intervals of not more

² Refer to RA 3531 - Helicopter Landing Site - Physical Characteristics.

**Acceptable
Means of
Compliance
3534(6)**

- than 30m on straight sections and not more than 15m on curves, with a minimum of four equally spaced markers per section.
19. Air Taxiway edge markings **should**:
 - a. Be located along the edges of a helicopter Air Taxiway; and
 - b. When on a paved surface, be yellow lines each 15cm in width, and spaced 15cm apart (nearest edge to nearest edge).
 20. Air Taxiway edge markers **should**:
 - a. Be located at a distance of 1m to 3m beyond the edge of the helicopter Air Taxiway. The markers **should** be placed no closer than 0.5 times the largest overall width for which it is designed from the centre-line of the helicopter Air Taxiway;
 - b. Be spaced at intervals of not more than 30m on each side of straight sections and not more than 15m on each side of curves, with a minimum of four equally spaced markers per section;
 - c. Be frangible; and
 - d. Have a minimum area of 150cm square.
 21. Air Taxiway edge markers **should not**:
 - a. Penetrate a plane originating at a height of 25cm above the plane of the helicopter Air Taxiway, at a distance of 1m from the edge of the helicopter Air Taxiway and sloping upwards and outwards at a gradient of 5% to a distance of 3m beyond the edge of the helicopter Air Taxiway;
 - b. Penetrate a plane originating at a height of 25cm above the plane of the helicopter Air Taxiway, at a distance of 0.5 times the largest overall width of the helicopter for which it is designed from the centre-line of the helicopter Air Taxiway, and sloping upwards and outwards at a gradient of 5%;
 - c. Exceed 35cm above ground or snow level;
 - d. Be used on helicopter Ground Taxiways. In this case, taxiway markers **should** be used as detailed in RA 3517(5)³.
 22. Air Taxiway markers:
 - a. **Should** be of colours that contrast effectively against the operating background;
 - b. **Should** be internally illuminated or retro-reflective if the Air Taxiway will be used at night; and
 - c. **Should not** use the colour red.

**Guidance
Material
3534(6)**

Permanent Helicopter Landing Site - Air Taxiway Markers and Markings

23. Where there is potential for a helicopter Air Taxiway to be confused with a helicopter Ground Taxiway, signage may be required to indicate the mode of taxi operations that are permitted.
 24. Good contrast and visibility can be achieved by having the marker divided into three equal, horizontal bands coloured yellow, green and yellow, respectively with a height to width ratio, as viewed by the pilot of 3 to 1 and a minimum area of the marker of 150cm square (Figure 6).
- Civil Equivalence.**
25. This regulation is in line with ICAO Annex 14 Vol II para 5.2.

³ Refer to RA 3517 – Permanent Fixed Wing Aerodrome - Markers.

**Guidance
Material
3534(6)**

Figure 6. Air Taxiway Marker Dimensions

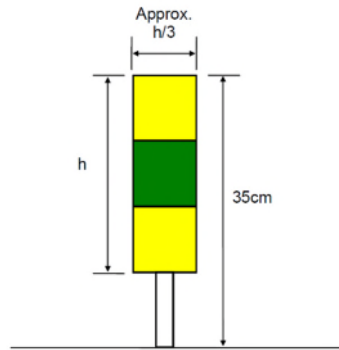

**Regulation
3534(7)**

Permanent Helicopter Landing Site - Air Taxi Route Markers

3534(7) HoEs and ADH Facing organizations **shall** ensure that Air Taxi routes, where established, are marked with Air Taxi route markers.

**Acceptable
Means of
Compliance
3534(7)**

Permanent Helicopter Landing Site - Air Taxi Route Markers

26. Air Taxi route markers **should**:
- Be located along the centre-line of the Air Taxi route and spaced at intervals of not more than 60m on straight sections and 15m on curves;
 - Be frangible;
 - Be of colours that contrast effectively against the operating background. The colour red **should not** be used for markers; and
 - Extend no greater than 1m above ground level.

**Guidance
Material
3534(7)**

Permanent Helicopter Landing Site - Air Taxi Route Markers

27. Good contrast and visibility can be achieved by having the marker divided into three equal, vertical bands coloured yellow, green and yellow, respectively with a height to width ratio, as viewed by the pilot, of 1 to 3 and a minimum area of the marker of 1500cm square (Figure 6).

Civil Equivalence.

28. This regulation is in line with ICAO Annex 14 Vol II para 5.2.

**Regulation
3534(8)**

Permanent Helicopter Landing Site - Helicopter Stand Markings

3534(8) HoEs and ADH Facing organizations **shall** ensure that helicopter stands, where established, are marked with helicopter stand markers.

**Acceptable
Means of
Compliance
3534(8)**

Permanent Helicopter Landing Site - Helicopter Stand Markings

29. Helicopter stand perimeter markings **should**:
- Be provided where a helicopter stand is designed for turning. If not practicable, a central zone perimeter marking **should** be provided instead if the perimeter of the central zone is not self-evident;
 - Be concentric with the central zone of the stand; and
 - Be a yellow circle and have a line width of 15cm (for both perimeter markings and a central zone marking if provided). If a TLOF is co-located with the helicopter stand, TLOF markings **should** be applied.
30. Helicopter stand stop line markings:

**Acceptable
Means of
Compliance
3534(8)**

- a. **Should** be provided where a helicopter stand is intended to be used for taxi-through and which does not allow the helicopter to turn;
 - b. **Should** be located on the helicopter Ground Taxiway at right angles to the centre-line; and
 - c. **Should not** be less than the width of the helicopter Ground Taxiway and have a thickness of 50cm.
31. Helicopter stand identification markings **should**:
- a. Be provided where there is a need to identify individual stands; and
 - b. Be marked in a contrasting colour to be easily readable.

**Guidance
Material
3534(8)**

Permanent Helicopter Landing Site - Helicopter Stand Markings

32. Where it is intended that helicopters proceed in one direction only, arrows indicating the direction to be followed may be added as part of the alignment lines.
33. Additional markings relating to stand size may be provided.

Civil Equivalence.

34. This regulation is in line with ICAO Annex 14 Vol II para 5.2.

**Regulation
3534(9)**

**Permanent Helicopter Landing Site - Flight Path Alignment
Guidance Marking**

- 3534(9) HoEs and ADH Facing organizations **shall** ensure that flight path alignment guidance marking(s) are provided at Permanent HLS where it is required to indicate available approach and/or departure path direction(s).

**Acceptable
Means of
Compliance
3534(9)**

**Permanent Helicopter Landing Site - Flight Path Alignment
Guidance Marking**

35. Flight path alignment guidance markings **should**:
- a. Be located in a straight line along the direction of approach and/or departure path on one or more of the TLOF, FATO, safety area or any suitable surface in the immediate vicinity of the FATO or safety area;
 - b. Consist of one or more arrows marked on the TLOF, FATO and/or safety area surface as shown in Figure 7. The stroke of the arrow **should** be 50cm in width and at least 3m in length; and
 - c. Be a colour which provides good contrast against the background colour of the surface on which they are marked, preferably white.

Figure 7. Flight Path Alignment Guidance Marking

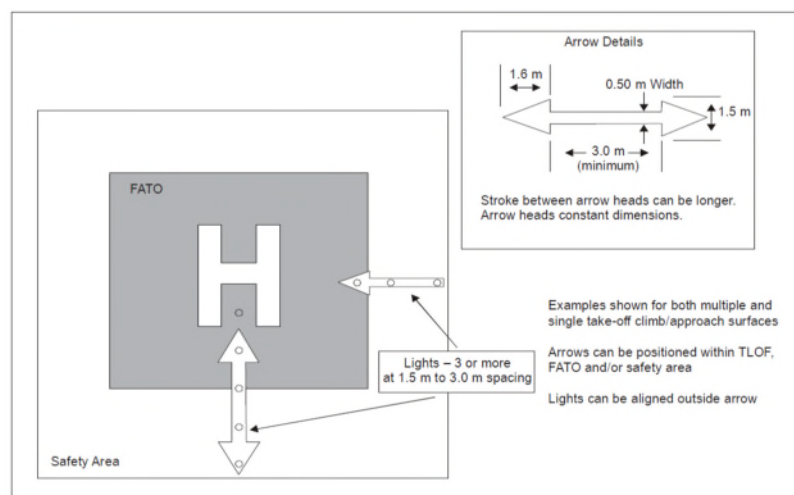

**Guidance
Material
3534(9)****Permanent Helicopter Landing Site - Flight Path Alignment
Guidance Marking**

36. In the case of a flight path limited to a single approach direction or single departure direction, the arrow marking may be unidirectional. In the case of a HLS with only a single approach / departure path available, one bidirectional arrow may be marked.

Civil Equivalence.

37. This regulation is in line with ICAO Annex 14 Vol II para 5.2.

RA 3535 - Helicopter Landing Site - Lighting

Rationale

In dusk or poor visibility conditions by day, lighting can be more effective than marking. Aeronautical Ground Lights (AGL) provide clear and consistent information and guidance to the operational community under all operating conditions.

Contents

- 3535(1): Permanent Helicopter Landing Site - Lighting
- 3535(2): Permanent Helicopter Landing Site - Approach Lights
- 3535(3): Permanent Helicopter Landing Site - Approach Guidance Systems
- 3535(4): Permanent Helicopter Landing Site - Helipad Lights
- 3535(5): Permanent Helicopter Landing Site - Air Transit Route Lights
- 3535(6): Permanent Helicopter Landing Site - Aeronautical Ground Lights Characteristics
- 3535(7): ► **Withdrawn – Incorporated into RA 3536(1): Domestic Helicopter Landing Sites – General Requirements** ◀

Regulation 3535(1)

Permanent Helicopter Landing Site - Lighting

3535(1) Heads of Establishments (HoEs) and Aviation Duty Holder-Facing Organizations (ADH-Facing Organizations) **shall** ensure that lighting installations on a Permanent Helicopter Landing Site (HLS) provide unambiguous guidance and **shall not** present a Hazard to other users in the vicinity of the Aerodrome.

Acceptable Means of Compliance 3535(1)

Permanent Helicopter Landing Site - Lighting

1. Apron, taxiway and obstacle lighting, on an HLS, **should** be in accordance with (iaw) RA 3515¹.

Dangerous or Confusing Lights.

2. A non-AGL which, due to its intensity, configuration or colour, might prevent or cause confusion in the clear interpretation of AGL **should** be extinguished, screened or otherwise modified to eliminate such a possibility.

3. In the case of HLS located near navigable waters, consideration **should** be given to ensuring that AGL do not cause confusion to mariners.

Beacons.

4. A Permanent HLS acquisition beacon **should**:

- a. Be located on or adjacent to the Permanent HLS preferably at an elevated position and so that it does not dazzle a pilot at short range;
- b. Be located such that the beacon is not shielded by objects in significant directions and does not dazzle a pilot approaching to land;
- c. Flash a coloured sequence of lights as follows: double peak white flash and a single peak green and yellow;
- d. Have a flash rate of 10-15 sequences of flashes per minute and the time between each colour **should** be one third of the total sequence time;

¹ Refer to RA 3515 – Permanent Fixed Wing Aerodrome - Lighting.

**Acceptable
Means of
Compliance
3535(1)**

- e. Be visible for 1.6 km, in Visual Meteorological Conditions (VMC) daylight, and 4.8 km, in VMC at night, both from an altitude of 915 m above ground level;
- f. Be installed more than 1.6 km from any existing airport heliport beacon;
- g. Be mounted a minimum of 15 m above the Permanent HLS surface and **should** be no closer than 122 m and no further than 1067 m from the Permanent HLS and **should not** be located between any control tower and the Permanent HLS; and
- h. Have its main beam of light aimed a minimum of 5° above the horizontal and **should not** produce light below the horizontal in excess of 1000 cd.

**Guidance
Material
3535(1)**

Permanent Helicopter Landing Site - Lighting

- 5. Light shields may be used to reduce the intensity below the horizontal to prevent dazzle to pilots.
- 6. An identification beacon may be installed at a Rotary Wing Permanent Base as well as an Acquisition Beacon, iaw RA 3515¹.

Civil Equivalence.

- 7. This Regulation is in line with International Civil Aviation Organization (ICAO) Annex 14 Vol II para 5.3.

**Regulation
3535(2)**

Permanent Helicopter Landing Site - Approach Lights

- 3535(2) HoEs and ADH-Facing Organizations **shall** ensure that an approach lighting system is provided at a Permanent HLS where there is a requirement to indicate a preferred approach direction. Additionally, a flight path alignment guidance lighting system(s) **shall** be provided at a HLS where there is a requirement to indicate available approach and / or departure path direction(s).

**Acceptable
Means of
Compliance
3535(2)**

Permanent Helicopter Landing Site - Approach Lights

Approach Lighting System.

- 8. An Approach Lighting System **should**:
 - a. Be in a straight line along the preferred direction of approach;
 - b. Consist of a row of three lights spaced uniformly at 30 m intervals and of a crossbar 18 m in length at a distance of 90 m from the perimeter of the Final Approach and Take Off (FATO) as shown in Figure 1;
 - c. Have the lights that form the crossbar situated as closely as practicable in a horizontal straight line at right angles to, and bisected by, the line of the centre-line lights and spaced at 4.5 m intervals;
 - d. Have additional lights spaced uniformly at 30 m intervals beyond the crossbar where there is the need to make the final approach course more conspicuous;
 - e. For both steady and sequenced flashing lights, be omnidirectional white lights;
 - f. If flashing lights are used, have a flash frequency of one per second with the flash sequence commencing from the outermost light and progressing towards the crossbar; and
 - g. Have a suitable brilliancy control incorporated to allow for adjustment of light intensity to meet the prevailing conditions.

Acceptable Means of Compliance 3535(2)

Figure 1. Approach Lighting System

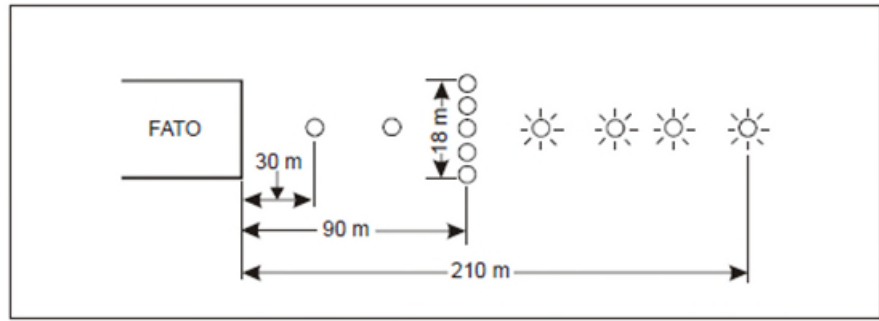

Flight Path Alignment Guidance Lighting System.

9. A Flight Path Alignment Guidance System **should**:
 - a. Be in a straight line along the directions of approach and / or departure path on one or more of the Touchdown and Lift Off (TLOF), FATO, Safety Area or any suitable surface in the immediate vicinity of the FATO, TLOF or Safety Area;
 - b. If combined with a flight path alignment guidance marking, as far as is practicable be located inside the “arrow” markings;
 - c. Consist of a row of three or more lights spaced uniformly a total minimum distance of 6 m as per Figure 2. Intervals between lights **should** be greater than 1.5 m but no more than 3 m;
 - d. Have steady omnidirectional inset white lights; and
 - e. Have a suitable brilliancy control incorporated to allow for adjustment of light intensity to meet the prevailing conditions.

Figure 2. Flight path alignment guidance markings and lights

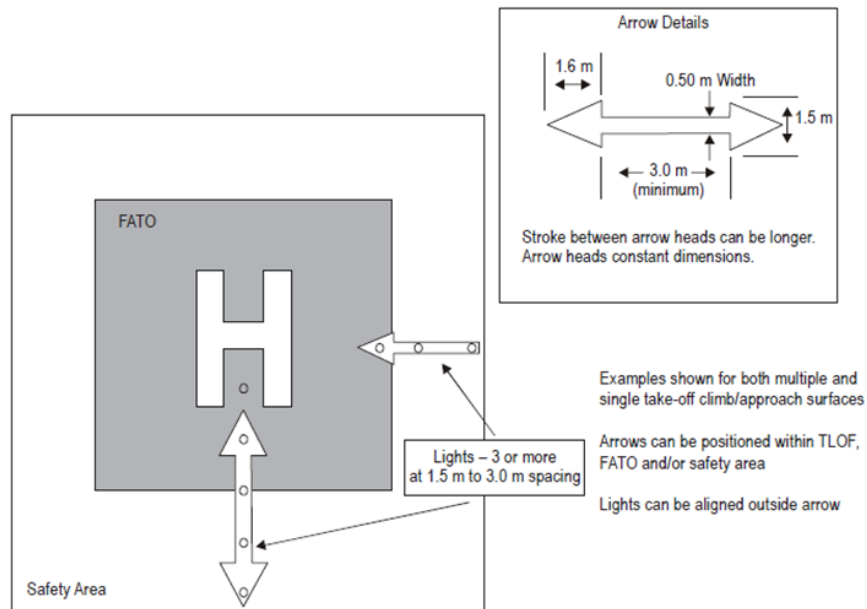

Guidance Material 3535(2)

Permanent Helicopter Landing Site - Approach Lights

10. The lights beyond the crossbar may be steady or sequenced flashing, depending upon the environment. Sequenced flashing lights may be useful where identification of the approach lighting system is difficult due to surrounding lights.
11. The following intensity settings have been found suitable:

**Guidance
Material
3535(2)**

- a. Steady lights - 100%, 30% and 10%; and
 - b. Flashing lights - 100%, 10% and 3%.
12. When operationally justified a NATO 'T' may be provided iaw STANAG 2999² (the NATO 'T' can be used for trooping and underslung loads without further lights or approach aids, but normally, only a single Air System can use the NATO 'T' at any one time.) The light units need to show variable white light with a minimum two stages of brilliancy. They need to show in all angles of azimuth and elevation necessary to provide guidance to a pilot landing or lifting-off and with an intensity adequate for the conditions of visibility and ambient light in which use of the 'T' is intended.
13. AGL for Helicopter Night Landing Training.
- a. Where helicopter night landing training is conducted at a Permanent HLS a six-light proportional T may be provided. The lights of the proportional T need to be omnidirectional, preferably white and useable from a distance of 4 nm.
 - b. When positioned on an aerodrome with a fixed wing Runway also in use, the proportional T needs to be sited to permit safe parallel approaches, to avoid obstructions and to minimize noise nuisance.
 - c. Procedures for the use of the proportional T need to be included in relevant aeronautical publications.
14. The flight path alignment guidance lighting can be combined with flight path alignment guidance markings described in RA 3534³.
15. The number of lights and spacing between these lights may be adjusted to reflect the space available, however 5 lights is considered the optimum number. If more than one flight path alignment system is used to indicate available approach and / or departure path directions, the characteristics for each system are typically kept the same.

Civil Equivalence.

16. This Regulation is in line with ICAO Annex 14 Vol II para 5.3.

**Regulation
3535(3)**

Permanent Helicopter Landing Site - Approach Guidance Systems

- 3535(3) HoEs and ADH-Facing Organizations **shall** ensure that additional guidance systems are provided to serve the approach to a Permanent HLS where one or more of the following conditions exist, especially at night: obstacle clearance, noise abatement or traffic control procedures which require a specific approach direction to be flown, the environment of the HLS provides few visual surface cues, and if it is physically impracticable to install an approach lighting system.

**Acceptable
Means of
Compliance
3535(3)**

**Permanent Helicopter Landing Site - Approach Guidance Systems
Visual Alignment Guidance System.**

17. A Visual Alignment Guidance System (VAGS) **should**:
- a. Be located such that a helicopter is guided along the prescribed track towards the FATO, ideally on the downwind edge of the FATO and aligned along the preferred approach direction;
 - b. Have light units that are frangible and mounted as low as possible;
 - c. Where the light sources are required to be discrete sources, have light sources located such that at the extremes of system coverage, the angle subtended between units as seen by the pilot is no less than 3 minutes of arc;

² Refer to STANAG 2999 – Use of Helicopters in Land Operations Doctrine.

³ Refer to RA 3534 – Helicopter Landing Site - Markings.

**Acceptable
Means of
Compliance
3535(3)**

- d. Have the angles subtended between light units of the system and other units of comparable or greater intensities no less than 3 minutes of arc;
- e. Have a signal format that:
 - (1) Includes a minimum of three discrete signal sectors providing “offset to the right”, “on track” and “offset to the left” signals;
 - (2) Ensures that there is no possibility of confusion between the system and any associated visual approach slope indicator or other visual aids; and
 - (3) Ensures that the system is unique and conspicuous in all operational environments.
- f. Have the divergence of the “on track” sector as shown in Figure 3;

Figure 3. Divergence of the “on track” sector

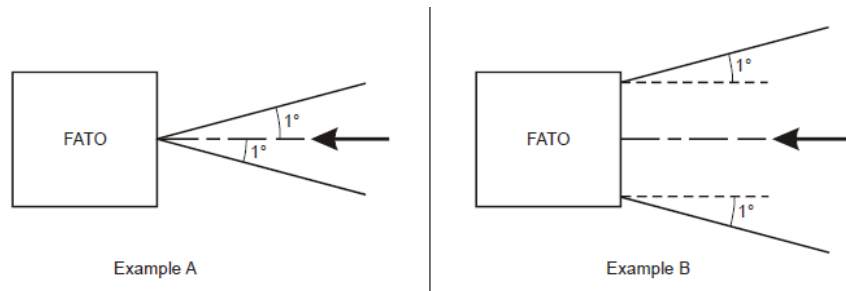

- g. Avoid the use of the same coding as any associated visual approach slope indicator;
- h. Have no significant increase on pilot workload;
- i. Have a usable coverage equal to or better than that of the visual approach slope indicator system with which it is associated;
- j. Have a suitable intensity control to allow adjustment to meet the prevailing conditions and to avoid dazzling the pilot during approach and landing;
- k. Be capable of adjustment in azimuth to within ± 5 minutes of arc of the desired approach path;
- l. Have the angle of its azimuth guidance system set such that, during an approach, the pilot of a helicopter at the boundary of the “on track” signal, clears all objects in the approach area by a safe margin;
- m. Have the requirements of the obstacle protection surface specified in RA 3532⁴ applied to the system;
- n. Automatically switch of the system in the event of the failure of any component affecting the signal format; and
- o. Be designed such that deposits of condensation, ice, dirt, etc, on optically transmitting or reflecting surfaces interfere to the least possible extent with the light signal and do not cause spurious or false signals to be generated

Visual Approach Slope Indicator.

- 18. The standard visual approach slope indicator systems for helicopter operations **should** consist of one of the following:
 - a. A Precision Approach Path Indicator (PAPI) system conforming to the specifications contained in RA 3515(8)⁵, except the on-slope section **should** be increased to 45 minutes;
 - b. An Abbreviated Precision Approach Path Indicator (APAPI) system; or

⁴ Refer to RA 3532 – Helicopter Landing Site - Obstacle Environment.

⁵ Refer to RA 3515(8): Approach Lighting – Precision Approach Path Indicator.

**Acceptable
Means of
Compliance
3535(3)**

- c. A Helicopter Approach Path Indicator (HAPI) system.
19. A visual approach slope indicator **should**:
- Be located such that a helicopter is guided to the desired position within the FATO and to avoid dazzling the pilot during final approach and landing;
 - Be located adjacent to the nominal aiming point and aligned in azimuth with the preferred approach direction;
 - Have light units that are frangible and mounted as low as possible; and
 - Have the requirements of the obstacle protection surface specified in RA 3532⁴ applied to the system.

Abbreviated Precision Approach Path Indicator.

20. An APAPI System **should** be installed where there is a requirement to fit a Visual Approach Slope Indicator and there is no existing PAPI or HAPI installation.
21. An APAPI **should**:
- Consist of 2 PAPI light units positioned on the left side of the TLOF on the lateral centre-line of the TLOF at 90° to the approach direction;
 - Have the inner light unit positioned at 10 m from the TLOF left edge, and the outer unit at 6 m from the inner unit;
 - Be constructed and mounted as low as possible, with a tolerance of plus or minus 30 cm, within the centre of the helipad elevation;
 - Be light in weight and on frangible mounts;
 - Have a suitable brilliancy control incorporated to allow for adjustment of light intensity to meet the prevailing conditions.
 - Conform to the specifications contained in RA 3515(8) other than where amended by RA 3535 and except that the on-slope sector of the system **should** be increased to 45 minutes; and
 - Conform with the vertical colour sectors for a 6° approach slope, as follows:
 - Above course (6.5° or more): WHITE / WHITE;
 - On course (6°): RED / WHITE; and
 - Below course (5.5° or less): RED / RED.

Helicopter Approach Path Indicator.

22. A HAPI System **should** be installed where there is a requirement to fit a Visual Approach Slope Indicator and there is no existing PAPI or APAPI installation.
23. A HAPI **should**:
- Have a signal format:
 - That includes four discrete signal sectors, providing an “above slope”, an “on slope”, a “slightly below” and a “below slope” signal;
 - As shown in Figure 4;
 - With a signal repetition rate of the flashing sector of the HAPI of at least 2 Hz, with an on-to-off ratio of the pulsing signals set at 1 to 1, and the modulation depth of at least 80%;
 - With an angular size of the “on-slope” sector of 45 minutes; and
 - With an angular size of the “slightly below” sector of 15 minutes.
 - Have light intensity distribution in red and green colours as described in RA 3535(6);
 - Have a colour transition of the HAPI in the vertical plane appear to an observer, at a distance of not less than 300 m, to occur within a vertical angle of not more than 3 minutes;

**Acceptable
Means of
Compliance
3535(3)**

- d. Have a transmission factor of a red or green filter not less than 15% at the maximum intensity setting;
- e. At full intensity, have a Y-coordinate of the red light not exceeding 0.320, and the green light within the boundaries specified RA 3535(6);
- f. Have a suitable intensity control provided to allow adjustment to meet the prevailing conditions and to avoid dazzling the pilot during approach and landing;
- g. Be capable of adjustment in elevation at any desired angle between 1° and 12° above the horizontal with an accuracy of ±5 minutes of arc;
- h. Have the angle of elevation setting of HAPI such that during an approach, the pilot of a helicopter observing the upper boundary of the “below slope” signal will clear all objects in the approach area by a safe margin;
- i. Have a light system designed that:
- (1) In the event the vertical misalignment of a unit exceeds ±0.5° (±30 minutes), the system will switch off automatically; and
 - (2) If the flashing mechanism fails, no light will be emitted in the failed flashing sectors.
- j. Be so designed that deposits of condensation, snow, ice, dirt, etc., on optically transmitting or reflecting surfaces interfere to the least possible extent with the light signals and **should not** affect the contrast between the red and white signals and the elevation of the transition sector.

Figure 4. Helicopter Approach Path Indicator

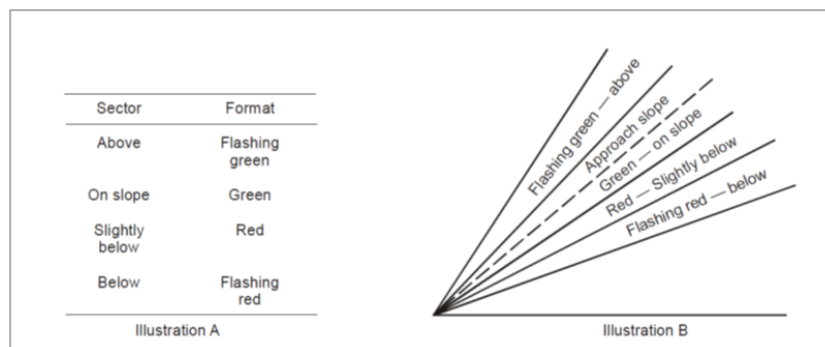

**Guidance
Material
3535(3)**

Permanent Helicopter Landing Site - Approach Guidance Systems

24. An example of where obstacle criteria may drive the need for a VAGS is where an aeronautical study indicates that an existing object extending above an obstacle protection surface could adversely affect the Safety of operations of helicopters and one of the following options is not practicable:
- a. Raising the approach slope of the system;
 - b. Reducing the azimuth spread of the system so that the object is outside the confines of the beam;
 - c. Displacing the axis of the system and its associated obstacle protection surface by no more than 5°; and
 - d. Displacing the FATO.
25. The requirements of sub-para c. and d. above can be met for lights on a line normal to the line of sight if the light units are separated by 1 m for every km of viewing range.
26. This RA applies to PAPI installation for HLS, APAPI and HAPI installations. The following specifications apply to PAPI, APAPI and HAPI:
- a. An obstacle protection surface needs to be established when it is intended to provide a visual approach slope indicator system.

**Guidance
Material
3535(3)**

- b. New objects or extensions of existing objects need not be permitted above an obstacle protection surface except when, in the opinion of the appropriate authority, the new object or extension would be shielded by an existing immovable object. (Note: Circumstances in which the shielding principle may reasonably be applied are described in the Airport Services Manual, Part 6 (Doc 9137)).
27. Existing Objects:
- a. Existing objects above an obstacle protection surface need to be removed except when, in the opinion of the appropriate authority, the object is shielded by an existing immovable object, or after aeronautical study it is determined that the object would not adversely affect the Safety of operations of helicopters.
- b. Where an aeronautical study indicates that an existing object extending above an obstacle protection surface could adversely affect the Safety of operations of helicopters, one or more of the following measures need to be taken:
- (1) Suitably raise the approach slope of the system;
 - (2) Reduce the azimuth spread of the system so that the object is outside the confines of the beam;
 - (3) Displace the axis of the system and its associated obstacle protection surface by no more than 5°;
 - (4) Suitably displace the FATO; and / or
 - (5) Install a visual alignment guidance system specified in RA 3535(3).
28. The lateral spacing between APAPI units may be increased to 9 m (± 1 m) if greater range is required or later conversion to a full PAPI is anticipated. In the latter case, the inner APAPI unit needs to be located 15 m (± 1 m) from the runway edge.
29. Care is required in the design of the units to minimize spurious signals between the signal sectors and at the azimuth coverage limits.

Civil Equivalence.

30. This Regulation is in line with ICAO Annex 14 Vol II para 5.3.

**Regulation
3535(4)**

Permanent Helicopter Landing Site - Helipad Lights

- 3535(4) HoEs and ADH-Facing Organizations **shall** ensure that, where a Permanent HLS is intended for use at night, lights are provided for the FATO, TLOF and Aiming point.

**Acceptable
Means of
Compliance
3535(4)**

Permanent Helicopter Landing Site - Helipad Lights

FATO Lights.

31. FATO lights **should**:
- a. Be placed along the edge of the FATO;
 - b. Be uniformly spaced:
 - (1) For an area in the form of a square or rectangle, at intervals of not more than 50 m with a minimum of four lights on each side including a light at each corner; and
 - (2) For any other shaped area, including a circular area, at intervals of not more than 5 m with a minimum of ten lights.
 - c. Be fixed omnidirectional lights showing white. Where the intensity of the lights **►needs to◀** be varied, the lights **should** show variable white, with a minimum of 3 stages of brilliancy.
 - d. Have lighting characteristics iaw Figure 7; and
 - e. Be no higher than 25 cm and be inset when a light extending above the surface would endanger helicopter operations. Where a FATO is not meant for lift-off or touchdown, the lights **should not** exceed a height of 25 cm above ground or snow level.

**Acceptable
Means of
Compliance
3535(4)**

Aiming Point Lights.

32. Aiming Point Lights **should**:
- Be collocated with the aiming point marking;
 - Form a pattern of at least six omnidirectional white lights as shown in Figure 5;
 - Be inset when a light extending above the surface could endanger helicopter operations; and
 - Have lighting characteristics iaw RA 3535(6).

Figure 5. Aiming Point Marking with Lights

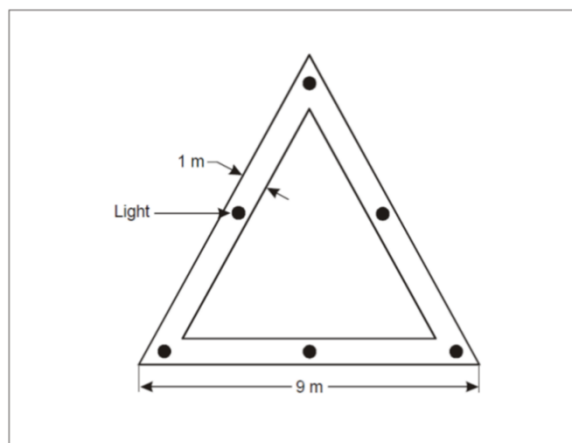

TLOF lights.

33. The TLOF lighting system **should** consist of one or more of the following:
- Perimeter lights; or
 - Floodlighting; or
 - Arrays of segmented point source lighting (ASPSL) or luminescent panel (LP) lighting to identify the TLOF when perimeter lights and floodlighting are not practicable and FATO lights are available.
34. TLOF perimeter lights **should**:
- Be placed along the edge of the area designated for use as the TLOF or within 1.5 m from the edge;
 - Where the TLOF is a circle:
 - Be located on straight lines in a pattern which will provide information to pilots on drift displacement; and
 - Where paragraph 33a is not practicable, be evenly spaced around the perimeter of the TLOF at the appropriate interval, except that over a sector of 45° the lights **should** be spaced at half spacing.
 - Be uniformly spaced at intervals of not more than 5 m with:
 - A minimum of 5 lights per square or rectangular TLOF including a light at each corner; and
 - A minimum of 14 lights for a circular TLOF.
 - Be fixed omnidirectional lights showing green; and
 - Be no greater than a height of 25 cm and inset when a light extending above the surface could endanger helicopter operations.
 - Be opposite each other when on opposite sides of the TLOF perimeter.
 - Have light distribution shown in Table 1.

**Acceptable
Means of
Compliance
3535(4)**

Table 1. Light Distribution of TLOF Lights (Azimuth +180° to -180°)

| Elevation (E) | Intensity |
|-------------------------------------|-----------|
| $20^{\circ} \leq E \leq 90^{\circ}$ | 3 cd |
| $13^{\circ} \leq E \leq 20^{\circ}$ | 8 cd |
| $10^{\circ} \leq E \leq 13^{\circ}$ | 15 cd |
| $5^{\circ} \leq E \leq 10^{\circ}$ | 30 cd |
| $2^{\circ} \leq E \leq 5^{\circ}$ | 15 cd |

35. TLOF floodlighting **should**:
- a. Be located to avoid glare to pilots in flight or to personnel working on the area. The arrangement and aiming of floodlights **should** be such that shadows are kept to a minimum:
 - (1) Floodlights **should** have no upward component of light output; the entire light output being directed below the horizontal;
 - (2) Provision **should** be made for the adjustment of the elevation of the floodlight beam after installation. The adjustment **should** provide movement of the axis of the projected beam from 1° above the plane to 5° below the horizontal reference plane.
 - b. When located within the Safety Area of a HLS, be no greater in height than 25 cm;
 - c. Be marked and lit as obstacles;
 - d. Have a spectral distribution such that the surface and obstacle marking can be correctly identified; and
 - e. Have an average horizontal illuminance of at least 10 lux, with a uniformity ratio (average to minimum) of not more than 8:1 measured on the surface of the TLOF.
36. ASPSL and LP lighting **should** be iaw ICAO Annex 14, Volume II, 5.3.9.

**Guidance
Material
3535(4)**

Permanent Helicopter Landing Site - Helipad Lights

37. A suitable brilliancy control, where provided, will allow for adjustment of light intensity to meet the prevailing conditions.

Civil Equivalence.

38. This Regulation is in line with ICAO Annex 14 Vol II para 5.3.

**Regulation
3535(5)**

Permanent Helicopter Landing Site - Air Transit Route Lights

3535(5) HoEs and ADH-Facing Organizations **shall** ensure that, where an Air Transit Route is intended to be used at night or during periods of low visibility, lighting is provided.

**Acceptable
Means of
Compliance
3535(5)**

Permanent Helicopter Landing Site - Air Transit Route Lights

39. Air Transit Route lights **should**:
- a. Be installed between the first and last points of surface movement (Figure 6);
 - b. Consist of a line of alternate green and yellow lights installed along the centre-line of the air transit route, commencing with green and terminating with yellow;
 - c. Have spacing of the lights of 15 m on curves and 30 m on straight routes;
 - d. Where an air transit route terminates at an apron or other area not intended for own power operation, be terminated with a terminating bar consisting of three unidirectional red lights spaced at 4.5 m centred on and perpendicular to

Acceptable Means of Compliance 3535(5)

the air transit route centre-line. The terminating bar **should** be placed at the beginning of the apron area;

- e. Be fixed omnidirectional lights showing green, yellow or red as applicable;
- f. Have a suitable intensity control to allow adjustment to meet the prevailing conditions and to avoid dazzling the pilot;
- g. Be mounted on frangible fittings located as near to the ground as possible;
- h. Be no greater in height than 250 mm above ground level. Where elevated light fittings would endanger helicopter operations the air transit route lights **should** be inset; and
- i. Have lighting characteristics iaw RA 3535(6).

Figure 6. Air Transit Route Lights

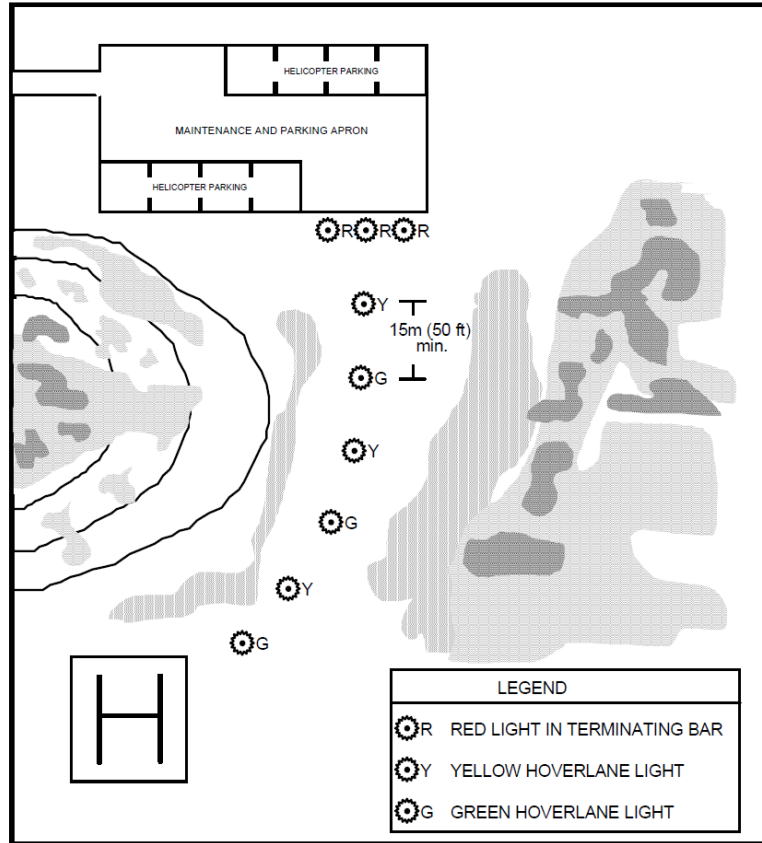

Guidance Material 3535(5)

Permanent Helicopter Landing Site - Air Transit Route Lights

40. Consideration may need to be given to selecting filter types or lamp sizes, which will provide the most consistent level of light output by the different coloured lights. The use of hoods that control the direction of light may be considered to avoid confusion with other HLS lights.

Regulation 3535(6)

Permanent Helicopter Landing Site - Aeronautical Ground Lights Characteristics

3535(6) HoEs and ADH-Facing Organizations **shall** ensure that all AGL fittings are of such construction, intensity and colour so that their presence does not endanger helicopters and is sufficient to provide adequate and appropriate guidance to aircrew.

Acceptable Means of Compliance 3535(6)

Permanent Helicopter Landing Site - Aeronautical Ground Lights Characteristics Construction.

41. AGL construction **should** be as per RA 3515(28)⁶.

Intensity.

42. The intensity and distribution of AGL **should** be iaw Figure 7.

Figure 7. Ground Lighting Characteristics

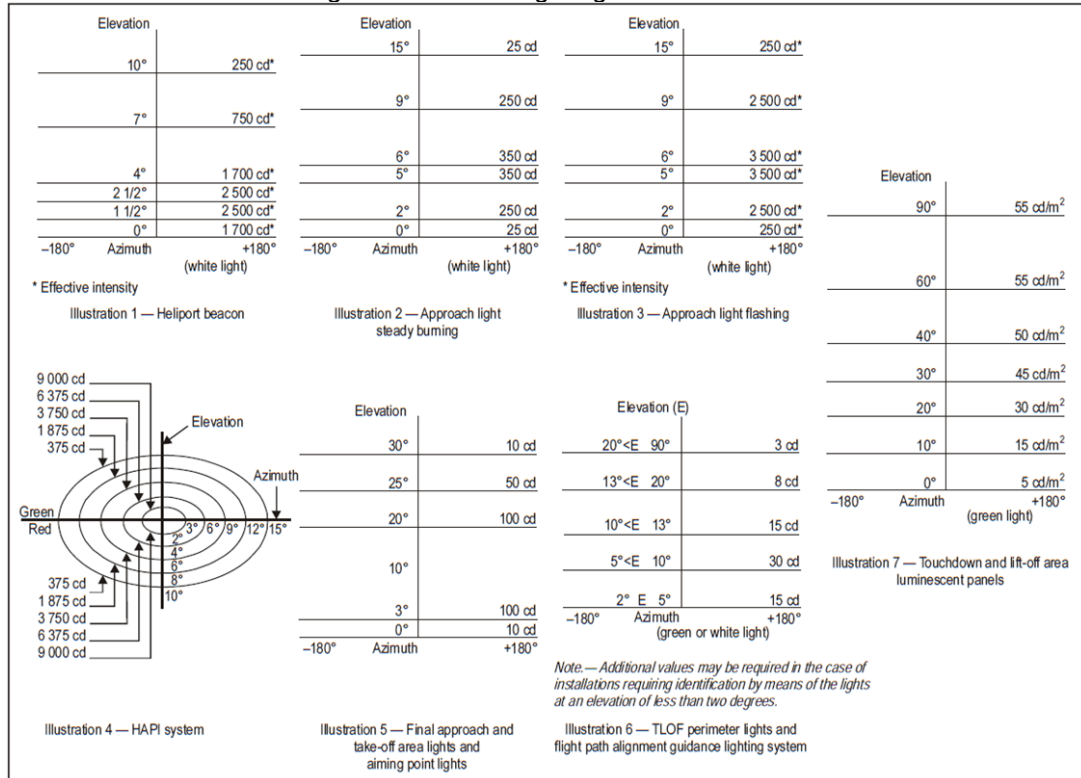

Colour.

43. Colour requirements for all AGL **should** be as detailed in ICAO Annex 14, Vol I, Appendix 1.

Guidance Material 3535(6)

Permanent Helicopter Landing Site - Aeronautical Ground Lights Characteristics

44. Nil.

Regulation 3535(7)

Domestic Helicopter Landing Site - Lighting and Signalling

3535(7) **▶ Withdrawn – Incorporated into RA 3536(1): Domestic Helicopter Landing Sites – General Requirements. ◀**

Acceptable Means of Compliance 3535(7)

Domestic Helicopter Landing Site - Lighting and Signalling

45. **▶ Withdrawn – Incorporated into RA 3536(1): Domestic Helicopter Landing Sites – General Requirements. ◀**

Guidance Material 3535(7)

Domestic Helicopter Landing Site - Lighting and Signalling

46. **▶ Withdrawn – Incorporated into RA 3536(1): Domestic Helicopter Landing Sites – General Requirements. ◀**

⁶ Refer to RA 3515(28): Aeronautical Ground Lights Characteristics – Construction.

► This RA has been substantially re-written; for clarity no change marks are presented – please read the RA in its entirety ◀

RA 3536 - Domestic Helicopter Landing Site

Rationale For a Safe Operating Environment (SOE) to be available at a Domestic Helicopter Landing Site (HLS) it is vital that the facilities, services and procedures are correctly enabled, published and managed. The absence of these provisions, or a misunderstanding of Responsibilities, could lead to unsafe operations or delay the response to an Incident. The correct preparation and management of a Domestic HLS, in accordance with (iaw) this Regulatory Article (RA), will enable the provision of an SOE iaw the site classification.

Contents

Scope

3536(1): Domestic Helicopter Landing Site – General Requirements

3536(2): Domestic Helicopter Landing Site – Classification and Specific Requirements

3536(3): Domestic Helicopter Landing Site Custodian – Responsibilities

3636(4): Domestic Helicopter Landing Site Custodian – Qualifications and Experience

Scope

The purpose of this RA is to provide a proportionate regulatory framework to ensure that Domestic HLS operations are conducted safely. A Domestic HLS is a facility, where there is no permanent Rotary Wing (RW) presence, which is designated only for the movement of Passengers, crew cargo or training and no other activities take place (eg Maintenance). It may be located in the UK or overseas and may contain one or more landing points.

For the avoidance of doubt, sites or facilities that support tactical and / or non-permanent HLS operations, that do not constitute the provision of a Domestic HLS, are outside the scope of this RA. Head of Establishment (HoE) responsibilities for such sites are contained in RA 1010(1)¹.

Regulation 3536(1)

Domestic Helicopter Landing Site – General Requirements

3536(1) HoE and Aviation Duty Holder-Facing Organizations and Accountable Manager (Military Flying)-Facing Organizations (AA-Facing Organizations) **shall** ensure that the following general requirements are achieved for all Domestic HLS.

Acceptable Means of Compliance 3536(1)

Domestic Helicopter Landing Site – General Requirements

1. A Suitably Qualified and Experienced Person (SQEP) HLS Custodian **should** be appointed to carry out the responsibilities within this RA.
2. Accurate details of the Domestic HLS **should** be submitted to Royal Air Force (RAF) No.1 Aeronautical Information Documents Unit (AIDU) for inclusion in the HLS Directory², including:
 - a. Location, operator and contact details.
 - b. Available facilities, services and procedures, including radio frequencies to be used.
 - c. Hazards, restrictions, and any other pertinent information.
3. An Emergency Plan **should** be established detailing immediate actions in the

¹ Refer to RA 1010(1): Classification Tier of Establishment.

² Refer to RA 1030 – Defence Aeronautical Information Management.

Acceptable Means of Compliance 3536(1)

event of an Aircraft Accident or serious Incident within the geographical boundary of the estate that the Domestic HLS is situated in.

4. An Incident Plan **should** be maintained to cope with the follow-on response to an Aircraft Accident or serious Incident, and to indicate within whose Post-Crash Management Area of Responsibility (AoR) the Domestic HLS falls, which unit will provide an Aircraft Post Crash and Incident Management (APCIM) response³ and the coordinating arrangements necessary to achieve it.
5. All Domestic HLS **should** operate on a Prior Permission Required (PPR) basis with current contact details published. Aircraft movement co-ordination should be recorded and managed to ensure time deconfliction of landing spot occupation.
6. During use, vehicle or pedestrian movement **should** not be permitted in the vicinity of the landing / take-off point⁴.
7. The Touchdown and Lift off (TLOF) surface **should** be periodically visually inspected to ensure that dangerous surface and other defects are identified in sufficient time to enable them to be rectified to prevent damage to Aircraft using it.
8. Where a Domestic HLS constitutes a movement area within the boundary of an existing Airfield, it **should** be included as part of the Airfield's maintenance schedule iaw with RA 3590⁵.
9. Where a Domestic HLS is located on an Aerodrome or Air Weapons Range, management of the Domestic HLS **should** be integrated into the Aerodrome's Air Safety Management System (ASMS) ensuring compliance with applicable Regulations iaw RA 1010⁶ Annex B.

Dimensions

10. The size of a Domestic HLS **should** be determined according to the largest overall dimension of the Aircraft, (D), that will use it, and established iaw the minimum dimensions in Figure 1.

Figure 1 – Minimum Dimensions for Domestic HLS

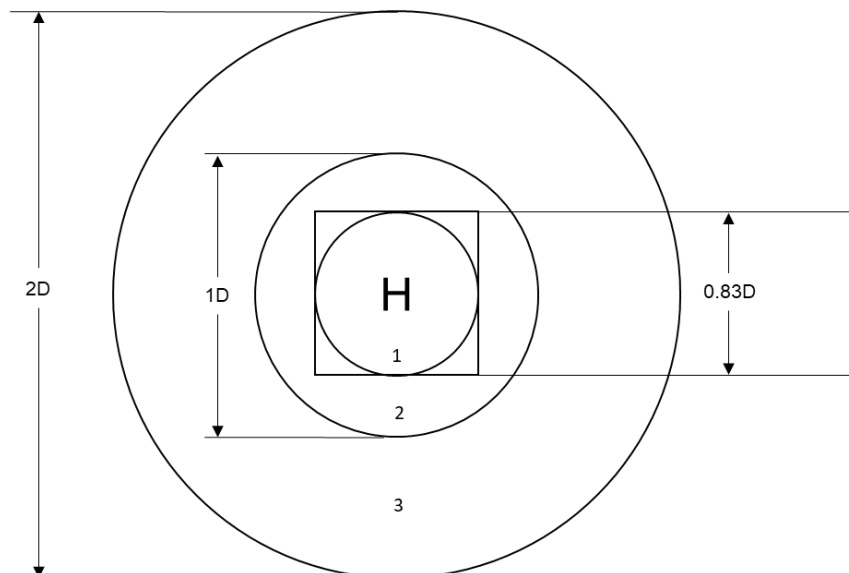

³ For further guidance, refer to RA 1430 – Aircraft Post Crash and Incident Management and Significant Occurrence Management, and the Manual of Aircraft Post Crash and Incident Management.

⁴ The exception being if the vehicle and pedestrian movement is part of the operating requirement of the Aircraft eg Passenger / equipment loading.

⁵ Refer to RA 3590 – Maintenance and Safeguarding.

⁶ Refer to RA 1010 – Head of Establishment Aviation Responsibilities and Aviation Duty Holder / Accountable Manager (Military Flying) Establishment Responsibilities.

**Acceptable
Means of
Compliance
3536(1)**

Surface

11. The surface of the TLOF **should** be even and sufficiently firm to support the safe and stabilized use of the intended Aircraft.
12. Ideally the TLOF will be level, however if a slope is present, the angle and direction **should** be annotated in the HLS Directory.
13. Prior to use, the TLOF **should**, as far as is practicable, be cleared of FOD that could be blown up by the rotor blades.
14. TLOFs with sandy or dusty surfaces **should** be stabilised or covered by an approved material.
15. Snow and ice **should** be removed from the TLOF, when required.

Obstacles

16. Obstacles **should** be limited iaw Figure 1 as follows:
 - a. Circle 1: TLOF free of obstacles.
 - b. Circle 2: Cleared to ground level.
 - c. Circle 3: Free of obstacles over 25cm high.
17. Beyond this area, and including the approach and exits paths, any pertinent obstacles assessed during survey, **should** be published in the HLS Directory, and lit where the HLS is intended for night use.

**Guidance
Material
3536(1)**

Domestic Helicopter Landing Site – General Requirements

18. The HoE may appoint themselves as HLS Custodian.
19. Whilst the HoE is ultimately responsible for ensuring that the Aeronautical Information submitted for publication in the HLS Directory is accurate, they may enlist the services of the Joint Helicopter Support Squadron (JHSS) to assist with establishing all the pertinent details and procedures for their facilities. JHSS can supply Suitably Qualified and Experienced Personnel for conducting surveys and recce of HLS surfaces, facilities, and obstacle environment.
20. It is expected that the Emergency Plan and Incident Plan will be proportionate to the classification of HLS and the expected frequency of activity. Further detail to support the creation of these plans can be found in the MAA Manual of Aircraft Post Crash and Incident Management, the MAA Manual of Air Safety, DSA02 DFRS – Defence Aerodrome Rescue and Fire Fighting (ARFF) Regulations and AP1269 Lft 12-08⁷.
21. An Emergency Plan will focus on immediate actions to preserve life and minimize damage in the event of an Aircraft emergency, including but not limited to: emergency contact numbers, rendezvous points, emergency services access, first aid provision⁸, available water supplies or fire suppression facilities⁷ and actions in the event of fire.
22. An Incident Plan will go beyond this to broader elements of post-crash management, preservation of evidence and securing the area. It is not expected that Domestic HLS units will hold their own, full, APCIM capability and that this will be provided under call-out arrangements within the wider AoR of another unit or organization. Further guidance is available in the MAA Manual of Aircraft Post Crash and Incident Management.
23. The HoE is only responsible for publishing the appropriate frequency to use, where one is available to be nominated. If none is available, there is no requirement to establish one for a Domestic HLS.
24. Larger dimensions than those illustrated at Figure 1 may be appropriate,

⁷ Refer to AP1269 – The RAF Manual of Medical Administration, Lft 12-08 – Guidance on the Standards of Medical Cover for Military Aerodromes.

⁸ This may be from civilian emergency services, Defence assets or locally provisioned first aid and fire-fighting appliances.

**Guidance
Material
3536(1)**

depending on the task being supported.

25. Whilst the dimensions of the TLOF are based on 'circle 1', it may be established as either a circle or a square / rectangle, provided the required dimensions are contained within it.

26. Where it is deemed proportionate to the activity being supported, units may consider establishing a schedule of proactive maintenance for the TLOF surface, to ensure that it remains free of harmful irregularities, defects and Foreign Object Debris (FOD).

**Regulation
3536(2)**

Domestic Helicopter Landing Site – Classification and Specific Requirements

3536(2) HoEs **shall** ensure that any Domestic HLS within their AoR is correctly classified and meets the corresponding requirements.

**Acceptable
Means of
Compliance
3536(2)**

Domestic Helicopter Landing Site – Classification and Specific Requirements

27. A Domestic HLS **should** be classified iaw Table 1, and meet the corresponding requirements in Annex A. If several Domestic HLS exist within the same site, each one **should** be individually classified.

Table 1. Domestic HLS Classifications

| Classification | Definition |
|---------------------------|--|
| Group 1: Transient | A surveyed area that can be used as a TLOF to facilitate a safe place for the arrival and departure of Military RW Aircraft It will likely have other day-to-day functions. It is not intended for use by civil RW Aircraft. |
| Group 2: Dedicated | A surveyed and permanently prepared TLOF to facilitate a safe place for the arrival and departure of Military RW Aircraft. It is not used for other functions. It may be used to accept civil RW Aircraft. |

**Guidance
Material
3536(2)**

Domestic Helicopter Landing Site – Classification and Specific Requirements

28. The classification of the HLS will determine the extent of HoE involvement in generating an assured SOE:

- a. Group 1 are typically, but not limited to, designated areas of car parks, parade squares or sports fields.
- b. Group 2 are the most regulated and will provide the most standardised and assured facility.

29. In determining whether a Group 1 facility warrants uplift to a Group 2 facility, the HoE may consider the type and frequency of activity being supported, in conjunction with SQEP advice from JHSS and / or the relevant ADH chain.

30. Civil use in the context of this RA refers to civilian owned and operated Aircraft that are not involved in a military task. However, regardless of the classification, best effort will be made to accommodate the safe use of a Domestic HLS by emergency services for operational reasons (eg – Air Ambulance, Police helicopters).

31. Full detail on Hazard management can be found in the MAA Manual of Air Safety.

**Regulation
3536(3)**

Domestic Helicopter Landing Site Custodian – Responsibilities

3536(3) The Domestic HLS Custodian **shall** be responsible for the management of the HLS to support the safe operation of Aircraft.

**Acceptable
Means of
Compliance
3536(3)**

Domestic Helicopter Landing Site Custodian – Responsibilities

32. The Domestic HLS Custodian **should** as a minimum:
- a. Ensure that the required SOE is being provided and maintained, through active management of their HLS iaw this RA.
 - b. Identify Hazards and reduce them as far as reasonably practicable.
 - c. Record and accurately promulgate Hazards iaw this RA.
 - d. Establish suitable testing activity, such that they can remain assured that the Emergency and Incident plans are current and effective.
 - e. Ensure that all Air Safety Occurrences are reported, iaw RA 1410⁹.
 - f. Provide Auditable Assurance to the HoE of continued compliance with all applicable RAs.
 - g. Identify and monitor any temporary decision, activity or change in circumstances that results in a Hazard or change to the published services / facilities provided.
 - h. Ensure the appropriate process is followed, iaw MAA03¹⁰, where compliance cannot be achieved.

**Guidance
Material
3536(3)**

Domestic Helicopter Landing Site Custodian – Responsibilities

33. HLS Custodians will assess the complexity and level of activity being supported and provide advice to the HoE as to whether the production of an Aerodrome Safe Operating Environment Manual (ASOEM), to support and enhance the management and Assurance of the HLS, is warranted.
34. Specific testing criteria and periodicity of the Emergency and Incident plans is not mandated, allowing the HLS Custodian to use their best judgement as to the most suitable and proportionate way to assure these contingencies.
35. The list of Domestic HLS Custodian responsibilities does not preclude the HoE from assigning the Domestic HLS Custodian additional responsibility that supports the safe operation of Aircraft.
36. There is no requirement for the Domestic HLS Custodian to be permanently based at the site in question. Day-to-day management of the HLS may be delegated, but the Domestic HLS Custodian retains full Responsibility.

**Regulation
3536(4)**

Domestic Helicopter Landing Site Custodian – Qualifications and Experience

3536(4) The Domestic HLS Custodian **shall** be SQEP.

**Acceptable
Means of
Compliance
3536(4)**

Domestic Helicopter Landing Site Custodian – Qualifications and Experience

37. The HoE **should** determine whether a candidate is SQEP for the intended duty.
38. A Domestic HLS Custodian **should**, as a minimum, have relevant experience and / or training within any of the following:
- a. Air Operations at an Aerodrome, HLS or His Majesty's (HM) Aircraft

⁹ Refer to RA 1410 – Occurrence Reporting and Management.

¹⁰ Refer to MAA03 – Military Aviation Authority Regulatory Processes.

**Acceptable
Means of
Compliance
3536(4)**

Carrier.

- b. A flying Squadron.
- c. Civil Airfield management.
- d. Specific training in HLS management.
- e. Training in aviation Hazard management.

39. If none of the criteria above are met, or if the HoE otherwise judges that the candidate lacks adequate experience or training, the individual **should** attend the Aerodrome Operators Study Period (AOSP) prior to appointment.

40. A HLS Custodian **should**, as a minimum, be qualified as an Air Safety Information Management System (ASIMS) Reporter and Commentator.

**Guidance
Material
3536(4)****Domestic Helicopter Landing Site Custodian – Qualifications and Experience**

41. ASIMS training is available online via individual ASIMS accounts.

Annex A

Domestic HLS Specific Requirements

| Requirement | Rationale | Group 1: Transient | Group 2: Dedicated |
|-----------------------------------|---|--|---|
| Surface | Enable operator awareness of the surface characteristics of the HLS. | Surface suitable for the intended Aircraft. Surface will likely have other day-to-day uses. | Surface permanently prepared and maintained for the intended Aircraft. The surface is not to be used for other purposes. |
| TLOF Markings¹¹ | Appropriate markings to identify the TLOF and its perimeter if this is not self-evident. Additional marking requirements to be established during survey. | Optional. | Required. |
| Wind Direction Indicator | Understanding the surface wind direction and strength is critical to facilitate safe operations. Where provided, Wind Direction Indicators are to be compliant with RA 3533 ¹² . | Optional. If not provided, this is to be published. | Required. |
| Lighting | Appropriate lighting, such as a NATO 'T' or floodlighting, is required if the HLS is available for use at Night. | Required. | Required. |
| Marshalling | A Marshaller may be required to assist with underslung load operations, or for positioning. Where provided, the Marshaller is to be SQEP. | Optional. | Optional. |

¹¹ Refer to RA 3534(4): Permanent Helicopter Landing Site - Touchdown and Lift Off Markings.

¹² Refer to RA 3533 – Helicopter Landing Site - Indicators and Signalling Devices.

Intentionally Blank for Print Pagination

RA 3550 - Temporary Landing Zone

Rationale

The employment of military ► **Aircraft** ◀ in a tactical role (in the UK or overseas) may require the establishment and / or utilization of a Temporary Landing Zone (TLZ). The austere nature of these locations may result in a lack of assured Aerodrome infrastructure which could introduce operating Hazards to ► **Aircraft** ◀. TLZ reconnaissance is required to ensure that a minimum set of Aerodrome infrastructure safeguarding and ► **Aircraft** ◀ operating requirements are established to minimise operating Hazards and mitigate Air Safety Risk.

Contents

3550(1): Temporary Landing Zone

3550(2): Temporary Landing Zone Establishment

Regulation

3550(1)

Temporary Landing Zone

3550(1) Aviation Duty Holders (ADH) and Accountable Managers (Military Flying) (AM(MF)) **shall** determine the ► **Aircraft** ◀ operating requirements for the utilization of a TLZ.

Acceptable Means of Compliance

3550(1)

Temporary Landing Zone

1. **Orders.** The 2 Group Operations Manual Part B Temporary Landing Zones underpins the safe planning and execution of TLZ operations ► **and** ◀ **should** be reviewed periodically by ADH and AM(MF) whose Aircraft may operate to a TLZ.
2. **Site Selection.** ADH and AM(MF) **should** consider the tactical requirements of the TLZ, supported by Flight Safety and engineering considerations.
3. **Airborne Reconnaissance.** In extremis, where use of an airborne TLZ reconnaissance is required the ADH or AM(MF) **should** pre-approve the activity. The ADH **should** define appropriate procedures.
4. **Risk Management (RM).** ADH and AM(MF) **should** ensure RM is conducted in accordance with (iaw) RA 1200¹, RA 1210² and the Manual of Air Safety to ensure that operating Hazards are correctly identified and any Risk to Life is mitigated and held at the appropriate level.

Guidance Material

3550(1)

Temporary Landing Zone

5. A TLZ is defined as an un-prepared, semi-prepared, matted or paved surface with smoothness, slope, dimensions, load-bearing capacity and clearance from obstacles sufficient to allow suitably trained crews to land and take-off safely in specified weather conditions.
6. An airfield whose details are published in the national AIP is not normally defined as a TLZ.

Regulation

3550(2)

Temporary Landing Zone Establishment

3550(2) ADH-Facing organizations **shall** determine the infrastructure safeguarding and operating requirements for the establishment and utilization of a TLZ.

¹ Refer to RA 1200 – Air Safety Management.

² Refer to RA 1210 – Ownership and Management of Operating Risk (Risk to Life).

**Acceptable
Means of
Compliance
3550(2)**

Temporary Landing Zone Establishment

7. **Orders.** ADH-Facing organizations **should** ensure that TLZs are established in accordance with the 2 Group Operations Manual Part B Temporary Landing Zones.
8. **Classification.** ADH-Facing organizations **should** ensure that in order for a TLZ to be accepted it is classified appropriately. This classification **should** indicate the level of detail contained in the TLZ reconnaissance report and the type of TLZ markings in use.
9. **Control.** ADH-Facing organizations **should** ensure that TLZs are controlled by **▶ a ◀** Suitably Qualified and Experienced Person. Standard ICAO phraseology, as outlined in CAP 413 Radiotelephony Manual, **should** be used.
10. **Crash / Rescue Provision.** ADH-Facing organizations **should** liaise with the relevant ADH to ensure that there is an adequate level of crash / rescue required for the activity.
11. **Physical Characteristics and Obstacle Environment.** ADH-Facing organizations **should** ensure that TLZ reconnaissance considers, but is not limited to, the following Aerodrome physical characteristics:
 - a. Manoeuvring area load bearing strength.
 - b. Manoeuvring area friction levels.
 - c. Manoeuvring area dimensions.
 - d. Manoeuvring area condition.
 - e. Obstacle Limitation Surfaces (ie longitudinal and transverse slopes).
 - f. Approach and departure zone.
 - g. Shoulders.
 - h. Undershoot / overrun.
 - i. Lateral safety zones.
 - j. Clear areas.
 - k. Transitional zones.
12. **Runway Tactical Marking and Lighting.** ADH-Facing organizations **should** ensure that marking and lighting standards are met to allow the safe operation of the **▶ Aircraft ◀**³, including the requirement for the Night Vision Device environment.
 - a. **▶ Person-marking ◀.** Where, in extremis due to operational necessity, "**▶ person-marking ◀**" is required prior permission **should** be granted by the ADH-Facing organization. Training for "**▶ person-marking ◀**" **should** also be authorized and conducted to support this requirement by the ADH-Facing organization.
 - b. **Closed Runway.** The ADH-Facing organization **should** publish procedures to communicate a runway closure.
13. **Radio Communication.** The minimum standards for communications **should** be established by the ADH-Facing organization. When landing information is not available via radio communications, indicators for wind direction and signalling devices for TLZ acquisition **▶ should ◀** be considered.
 - a. **No Communications.** The ADH-Facing organization **should** publish procedures to provide guidance if there is an instance where communications cannot be established.
14. **Taxiway and Apron Marking.** ADH-Facing organizations **should** ensure that markings are sufficient to allow crews to determine the safe operating limits of the manoeuvring area.

³ Refer to STANAG 3534 Airfield Lighting, Marking and Tone Down Systems for Non-Permanent/Deployed Operations.

**Acceptable
Means of
Compliance
3550(2)**

15. **Risk Management (RM).** ADH-Facing organizations **should** ensure RM is conducted iaw RA 1200¹, RA 1210² and the Manual of Air Safety to ensure that operating Hazards are correctly identified.

16. **Infrastructure Improvements.** When long-term use of a TLZ is planned and future large-scale infrastructure improvements are likely, the ADH-Facing organization **should** ensure that the reconnaissance gives due consideration to the possibility of the TLZ being improved to a permanent airfield, where normal airfield criteria would apply.

**Guidance
Material
3550(2)****Temporary Landing Zone Establishment**

17. Nil.

Intentionally Blank for Print Pagination

RA 3590 - Maintenance and Safeguarding

Rationale

An Aerodrome or Helicopter Landing Site (HLS) is intended to be a safe place for Aircraft to operate from. Inadequate Maintenance and safeguarding of Aerodrome facilities could increase Aviation Risk to Life and be instrumental in Aircraft Occurrences. Appropriate Maintenance and safeguarding of an Aerodrome or HLS will ensure that all Aerodromes and HLS continue to meet functional requirements and Regulations and ensure that whole life costs and disruption to Aircraft operations are minimized.

Contents

- 3590(1): Maintenance - General**
- 3590(2): Maintenance - Pavements - Friction**
- 3590(3): Maintenance - Pavements - Inspection**
- 3590(4): Maintenance - Pavements - Removal of Contaminants**
- 3590(5): Maintenance - Inspections - Measured Height Surveys**
- 3590(6): Maintenance - Inspections - Compass Calibration Bases Periodic Surveys and Annual Checks**
- 3590(7): Maintenance - Visual Aids**
- 3590(8): Safeguarding - MOD Property**
- 3590(9): Safeguarding - Outside MOD Property**
- 3590(10): Safeguarding - Surface Obstructions**
- 3590(11): Safeguarding - Sub-Surface Obstructions**
- 3590(12): Safeguarding - Operationally Essential Obstructions**

Regulation 3590(1)

Maintenance - General

3590(1) Heads of Establishments (HoEs) and Aviation Duty Holder-Facing organizations (ADH-Facing organizations) **shall** ensure that an appropriate Maintenance programme, including preventive and reactive / corrective Maintenance, is established at an Aerodrome and / or HLS to maintain facilities in a condition which does not impair the Safety, or efficiency of air navigation and operation on the ground.

Acceptable Means of Compliance 3590(1)

Maintenance - General

1. The design and application of the Maintenance programme **should** observe Human Factors principles in accordance with (iaw) the Human Factors Training Manual (International Civil Aviation Organization (ICAO) Doc 9683) and in the Airport Services Manual (ICAO Doc 9137), Part 8.

Guidance Material 3590(1)

Maintenance - General

2. Preventive Maintenance is programmed Maintenance work done in order to prevent a failure or degradation of facilities.

3. "Facilities" are intended to include such items as pavements, visual aids, fencing, drainage systems, electrical systems and buildings.

Civil Equivalence

4. This Regulation is in line with ICAO Annex 14 Vol I para 10.1.1 – 10.1.2.

**Regulation
3590(2)**

Maintenance - Pavements - Friction

3590(2) HoEs and ADH-Facing organizations **shall** ensure that the surfaces of all Runways have their friction conditions monitored regularly as part of an Aerodrome preventive and corrective Maintenance programme.

**Acceptable
Means of
Compliance
3590(2)**

Maintenance - Pavements - Friction

5. The surface of a Runway **should** be maintained in a condition such as to prevent formation of harmful irregularities and Foreign Object Debris (FOD).
6. A paved Runway **should** be maintained in a condition so as to provide surface friction characteristics at or above the minimum friction level specified by the MOD.
7. Runway surface friction characteristics for Maintenance purposes **should** be periodically measured with a MOD specialist approved continuous friction measuring device, and documented. The frequency of these measurements **should** be sufficient to determine the trend of the surface friction characteristics of the Runway.
8. Corrective Maintenance action **should** be taken to prevent the Runway surface friction characteristics for either the entire Runway or a portion thereof from falling below a minimum friction level specified in ICAO Annex 14 Vol I Attachment A, section 7.
9. Aerodromes **should** carry out 3 types of Runway friction testing:
 - a. Runway Friction Classification Surveys (organized centrally by a MOD Specialist).
 - b. Runway Friction Monitoring Surveys (organized and undertaken by Air Traffic Control (ATC) locally).
 - c. Special Friction Surveys (organized centrally by an MOD Specialist).
10. As described in Annex A, procedures for special friction surveys **should** be detailed by the MOD specialists on a case-by-case basis.
11. The Maintenance Planning Level (MPL) and Minimum Friction Level (MFL)¹ **should** be as presented in Annex A.
12. Aerodromes **should** record friction survey reports using the templates presented in Annex A. All data and reports **should** be retained by the Aerodromes.
 - a. Average friction reading of each track **should** be correctly identified, and highlights of significant features of the test detailed.
 - b. Friction values **should** be marked on a plan of the Runway showing exact location and friction values as measured.
 - c. The following photographs **should** be taken (each close-up photograph is to include a scale rule within the shot):
 - (1) Location shot showing complete extent of rubber deposits at each Runway end (not required for night surveys);
 - (2) Close-up of rubber deposits (not required for night surveys);
 - (3) Close-up of Runway surface; and
 - (4) Any significant features on the Runway surface (not required for night surveys).
13. Where the measured friction value of a portion of a Runway has deteriorated to the MFL value or less, the Runway **should** be notified as “liable to be slippery when wet”.
14. When a Runway is notified as “liable to be slippery when wet”, take-off and landing in wet conditions **should** only be considered when the distances available

¹ Refer to CAP 683: The Assessment of Runway Surface Friction Characteristics.

**Acceptable
Means of
Compliance
3590(2)**

equal or exceed those required for a very slippery or icy Runway as determined from the information in the Aircraft's Flight Manual.

**Guidance
Material
3590(2)**

Maintenance - Pavements - Friction

15. The determination of Maintenance / restoration requirements to ensure that pavements remain safe for Aircraft operations is dependent on Airfield pavement evaluation procedures involving professional surveys, site testing and investigations. Procedures may also include Runway friction classification and monitoring surveys. Both the monthly and biennial pavement inspections are limited to surface condition assessments. However, if either unanticipated or abnormal distresses are noted, further and more detailed site investigations may be required.

16. The inherent friction characteristics of a paved surface deteriorate slowly over time. However, the friction of a Runway surface and the related braking action can vary significantly over a short period due to the presence of contaminants eg snow, ice, slush and water.

Civil Equivalence

17. This Regulation is in line with ICAO Annex 14 Vol I para 10.2.1 – 10.2.7.

**Regulation
3590(3)**

Maintenance - Pavements - Inspection

3590(3) HoEs and ADH-Facing organizations **shall** ensure that the surfaces of all movement areas including pavements (Runways, taxiways and Aprons) and adjacent areas (hardstandings, hangar floors, Hardened Aircraft Shelter floors, wash platforms etc) are inspected and their conditions monitored regularly as part of an Aerodrome and / or HLS preventive and corrective Maintenance programme.

**Acceptable
Means of
Compliance
3590(3)**

Maintenance - Pavements - Inspection

18. The surface of all movement areas **should** be maintained in a condition such as to prevent formation of harmful irregularities, harmful defects or FOD.

19. The surface condition of all Airfield Operating Surfaces in current use **should** be periodically visually inspected to ensure that dangerous surface and other defects are identified in sufficient time to enable them to be rectified to prevent damage to airframes using that surface.

20. The following types of visual inspection **should** be carried out:

- a. Monthly inspections (undertaken by the site Maintenance organization iaw Defence Infrastructure Organisation (DIO) Practitioner Guide PG 06/11).
- b. Biennial Inspections (organized and undertaken by the MOD specialist or their approved consultant).

21. Standard of Repairs: All Repairs undertaken on any operating surface **should** comply with the recommendations set out in Defence Works Functional Standard 06 Guide to Airfield Pavement Maintenance ("FS06").

**Guidance
Material
3590(3)**

Maintenance - Pavements - Inspection

22. The determination of Maintenance / restoration requirements to ensure that pavements remain safe for Aircraft operations is dependent on Aerodrome and / or HLS pavement evaluation procedures involving professional surveys and site testing and investigations. Procedures may include monthly and biennial inspections of pavement surfaces and Runway friction classification and monitoring surveys. Monthly inspections are carried out by Aerodrome Maintenance staff as a regular check on pavement condition and also to aid determination of short-term Maintenance

Guidance Material 3590(3)

requirements and to check works undertaken / completed. Biennial inspections are carried out by specialist teams mainly for the purpose of providing long-term strategic Maintenance / restoration work forecasts but also to provide Assurance of the short-term Maintenance planning process.

23. The functional requirements and the evaluation / assessment of pavements in relation to the various distress types provide the basic technical inputs for producing optimum design / Maintenance solutions. Minor and / or preventative measures in many instances can provide a cost-effective means of complying with the functional requirements. However, the stringency of the functional requirements including future access constraints will have a considerable bearing on the latitude for ongoing Maintenance / small works programmes and also on options for restoration / major works.

24. For guidance on Maintenance measures including their application, reference can be made to Defence Works Functional Standards 06 - "Guide to Airfield Pavement Maintenance FS06". MOD specialists can provide design advice in relation to the distress mechanisms. Site Maintenance organizations are free to propose alternative techniques and / or materials to those set out in FS06 although these will be evaluated by the MOD specialist on a site by site basis.

Regulation 3590(4)

Maintenance - Pavements - Removal of Contaminants

3590(4) HoEs and ADH-Facing Organizations **shall** ensure that
 ► contaminants on the Movement Area are adequately managed to enable the safe operation of Aircraft at all times. ◀

Acceptable Means of Compliance 3590(4)

Maintenance - Pavements - Removal of Contaminants

25. ► Contaminants, such as snow, slush and ice **should** be addressed iaw RA 3278².

26. Other temporary contaminants, such as mud or sand, **should** be removed as soon as practicable to minimize accumulation, which can be achieved through routine or ad hoc sweeping operations.

27. Contaminants from Aircraft and / or vehicles, such as fuel or oil, **should** be subject to environmental management iaw RA 1800³ and removed as soon as possible to minimize environmental impact and damage to the affected surface.

28. The presence of cumulative contaminants, such as rubber deposits, **should** be monitored through routine inspections and friction testing to avoid accumulations. Such contaminants **should** be removed as soon as practicable, noting that specialist equipment is likely to be required and **should** be factored into the routine Maintenance of the Movement Area.

29. The use of chemicals for the removal of contaminants **should** be subject to environmental management iaw RA 1800. ◀

30. The friction of the area treated **should** be measured periodically after the contaminants are removed, ► iaw RA 3272(1)⁴.

31. The evaluation and reporting of Runway surface conditions **should** be carried out iaw RA 3272(2)⁵. ◀

² ► Refer to RA 3278 – Snow and Ice Operations.

³ Refer to RA 1800 – Aerodrome and Air Weapon Range Aviation Activity - Management of Environmental Impacts and Risks.

⁴ Refer to RA 3272(1): Continuous Friction Measuring Equipment.

⁵ Refer to RA 3272(2): Reporting of Runway Surface Conditions. ◀

**Guidance
Material
3590(4)**

Maintenance - Pavements - Removal of Contaminants

32. ► Further guidance on the control and removal of contaminants is contained in ICAO Doc 9137 – Airport Services Manual, Part 2⁶ and CAP 168 – Licensing of Aerodromes, Appendix 3G⁷. ◀

Civil Equivalence

33. This Regulation is in line with ICAO Annex 14 Vol I ► ninth edition, ◀ para 10.3.1 – 10.3.6.

**Regulation
3590(5)**

Maintenance - Inspections - Measured Height Surveys

3590(5) HoEs and ADH-Facing organizations **shall** ensure that Measured Height Surveys are completed.

**Acceptable
Means of
Compliance
3590(5)**

Maintenance - Inspections - Measured Height Surveys

34. A Measured Height Survey **should** be completed annually, or at frequencies determined iaw Civil Aviation Publication (CAP) 232⁸ or CAP 1732⁹ as applicable.

35. Professional inspection of the pavement and visual aids services and associated infrastructure at an Aerodrome **should** be carried out at suitable frequency.

**Guidance
Material
3590(5)**

Maintenance - Inspections - Measured Height Surveys

36. Nil.

**Regulation
3590(6)**

Maintenance - Inspections - Compass Calibration Bases Periodic Surveys and Annual Checks

3590(6) HoEs and ADH-Facing organizations **shall** ensure that all visual aids equipment, installation and facilities including supporting infrastructures and facilities **shall** be inspected and, as applicable, their conditions and performances be measured, tested and monitored regularly as part of an Aerodrome preventive and corrective Maintenance programme, with the objective of achieving the high levels of reliability of visual aids to properly support Aerodrome operation and to maintain Safety.

**Acceptable
Means of
Compliance
3590(6)**

Maintenance - Inspections - Compass Calibration Bases Periodic Surveys and Annual Checks

37. The officer responsible for Aircraft compass swinging, normally the Station Navigation Officer, is also responsible for the periodic, resurvey and annual check of the compass calibration base. In addition, they are to ensure that the station services are aware that paving Repairs **should** be carried out using materials approved by QinetiQ, MOD Portland Bill. They **should** also notify QinetiQ, Land Magnetic Facilities at the earliest opportunity of any planned work within 200 m of the centre of the compass base.

38. Periodic surveys of all compass bases **should** be undertaken by staff from QinetiQ, Land Magnetic Facilities. Class 1 bases **should** be re-surveyed every 5 years. However, Class 2 bases are normally subject to magnetic anomalies, the effects of which are liable to change with time; these bases **should** therefore be re-surveyed every 2 years.

⁶ ► Refer to ICAO Doc 9137 – Airport Services Manual, Part 2.

⁷ Refer to CAP 168 – Licensing of Aerodromes. ◀

⁸ Refer to CAP 232 – Aerodrome Survey Information.

⁹ Refer to CAP 1732 – Aerodrome Survey Guidance.

**Acceptable
Means of
Compliance
3590(6)**

39. At least once a year, the officer responsible for the compass calibration base **should** visit the base to check:
- That the datum compass circle is clearly and adequately marked.
 - That no work has been carried out on or around the compass base which might alter its magnetic properties. Any suspect areas **should** be subjected to a detailed magnetic survey.
 - That no magnetic objects such as metal chocks, fire extinguishers, reinforced concrete or cables have been placed within the site.
40. If any doubts about the magnetic integrity of the compass base arise during the annual check or at any time, the officer responsible for the base **should** contact QinetiQ, Land Magnetic Facilities for advice.

**Guidance
Material
3590(6)**

Maintenance - Inspections - Compass Calibration Bases Periodic Surveys and Annual Checks

41. Nil.

**Regulation
3590(7)**

Maintenance - Visual Aids

- 3590(7) HoEs and ADH-Facing organizations **shall** ensure that a system of preventive Maintenance of visual aids is employed to ensure lighting and marking system reliability.

**Acceptable
Means of
Compliance
3590(7)**

Maintenance - Visual Aids

42. When in use, the operational status of the Aeronautical Ground Lighting (AGL) system **should** be continuously monitored. An appropriate means of detecting an AGL system failure or Fault and other serviceability information **should** be provided. The AGL system serviceability information **should** be provided to the AGL operator in a simple but accurate and concise way, so that if necessary the user can pass a report to Aircrew. The report will enable Aircrew to determine whether the AGL meets their current operational flight requirements or not.
43. A light **should** be deemed to be unserviceable when the main beam average intensity is less than 50% of the value specified. For light units where the designed main beam average intensity is above the design value, the 50% value **should** be related to that design value. Where more than one light is used in a unit, the unit is considered to be unserviceable if its light output is similarly reduced.
44. The system of preventive Maintenance employed for a Runway **should** include at least the following checks:
- Visual inspection and in-field measurement of the intensity, beam spread and orientation of lights included in the approach and Runway lighting systems;
 - Control and measurement of the electrical characteristics of each circuitry included in the approach and Runway lighting systems; and
 - Control of the correct functioning of light intensity settings used by ATC.
45. In-field measurement of intensity, beam spread and orientation of lights included in approach and Runway lighting systems for a Runway **should** be undertaken by measuring all lights, as far as practicable, to ensure conformance with the applicable specification.
46. Measurement of intensity, beam spread and orientation of lights included in approach and Runway lighting systems for a Runway **should** be undertaken using a mobile measuring unit of sufficient accuracy to analyse the characteristics of the individual lights.
47. The frequency of measurement of lights for a Runway **should** be based on traffic density, the local pollution level, the reliability of the installed lighting equipment and the continuous assessment of the results of the in-field measurements but, in any

**Acceptable
Means of
Compliance
3590(7)**

event, for CAT II and III and LV Operations, the measurement **should not** be less than twice a year for in-pavement lights and not less than once a year for other lights.

48. The system of preventive Maintenance employed for a precision approach Runway Category II or III **should** have as its objective that, during any period of Category II or III operations, all approach and Runway lights are serviceable and that, in any event, at least:

- a. 95% of the lights are serviceable in each of the following particular significant elements:
 - (1) Precision approach category II and III lighting system, the inner 450 m;
 - (2) Runway centre-line lights;
 - (3) Runway threshold lights; and
 - (4) Runway edge lights;
- b. 90% of the lights are serviceable in the touchdown zone lights;
- c. 85% of the lights are serviceable in the approach lighting system beyond 450 m; and
- d. 75% of the lights are serviceable in the Runway end lights.

49. In order to provide continuity of guidance, the allowable percentage of unserviceable lights **should not** be permitted in such a way as to alter the basic pattern of the lighting system. Additionally, an unserviceable light **should not** be permitted adjacent to another unserviceable light, except in a barrette or a crossbar where two adjacent unserviceable lights may be permitted.

50. The system of preventive Maintenance employed for a stop bar provided at a Runway-holding position used in conjunction with a Runway intended for operations in Runway Visual Range (RVR) conditions less than a value of 350 m **should** have the following objectives:

- a. No more than two lights will remain unserviceable; and
- b. Two adjacent lights will not remain unserviceable unless the light spacing is significantly less than that specified.

51. The system of preventive Maintenance employed for a taxiway intended for use in RVR conditions less than a value of 350 m **should** have as its objective that no two adjacent taxiway centre-line lights be unserviceable.

52. The system of preventive Maintenance employed for a precision approach Runway Category I **should** have as its objective that, during any period of Category I operations, all approach and Runway lights are serviceable and that, in any event, at least 85% of the lights are serviceable in each of the following:

- a. Precision approach Category I lighting system;
- b. Runway threshold lights;
- c. Runway edge lights; and
- d. Runway end lights.

53. In order to provide continuity of guidance an unserviceable light **should not** be permitted adjacent to another unserviceable light unless the light spacing is significantly less than that specified.

54. The system of preventive Maintenance employed for a Runway meant for take-off in RVR conditions less than a value of 550 m **should** have as its objective that, during any period of operations, all Runway lights are serviceable and that in any event:

- a. At least 95% of the lights are serviceable in the Runway centre-line lights (where provided) and in the Runway edge lights; and

**Acceptable
Means of
Compliance
3590(7)**

- b. At least 75% of the lights are serviceable in the Runway end lights.
55. The system of preventive Maintenance employed for a Runway meant for take-off in RVR conditions of a value of 550 m or greater **should** have as its objective that, during any period of operations, all Runway lights are serviceable and that, in any event at least 85% of the lights are serviceable in the Runway edge lights and Runway end lights.
56. In order to provide continuity of guidance, an unserviceable light **should not** be permitted adjacent to another unserviceable light.
57. During low visibility procedures the appropriate authority **should** restrict construction or Maintenance activities in the proximity of Aerodrome and / or HLS electrical systems.
58. General inspection and Maintenance **should** include cleaning, checks on electro-mechanical, Structural Integrity of installation and normal function, Repair and replacement of all visual aids facilities and their supporting infrastructures. Precision Approach Path Indicator (PAPI) serviceability gives rise to additional considerations as moisture and / or dirt on the lenses will diffuse the beam and can result in a white signal being emitted at all angles of elevation. To prevent this potentially hazardous situation from occurring additional measures **should** be adopted as follows:
- a. Daily inspection to ensure:
 - (1) All lamps are operational and evenly illuminated.
 - (2) There is no damage to units.
 - (3) All lenses are clean.
 - (4) The change from red to white is coincident for all elements of a unit.
 - (5) The heating facilities are functioning correctly.
 - b. Bi-monthly inspection to ensure:
 - (1) Vertical alignment of each PAPI unit to a tolerance of ± 1 minute of arc.
 - (2) Azimuth alignment of each PAPI to a tolerance of ± 1 minute of arc.
 - c. Yearly inspection:
 - (1) Internal inspection of unit.
 - (2) Correct setting of black heat current (approx. 1.5 A RMS).
59. A PAPI wing bar installation **should** be withdrawn from service if one unit within the wing bar is found to be unserviceable.
60. Setting angles **should** be checked with a manufacturer's clinometer or platforms. A theodolite or equivalent device may be used for increased accuracy. Errors in excess of 1 minute of arc **should** be corrected.
61. After installation, the angles **should** initially be checked on a daily basis using a clinometer or equivalent device and, if necessary, adjusted using a theodolite or equivalent device. The interval between checks may be extended progressively to once a week, as greater stability becomes evident. However, special checks **should** be made in the event of heavy frost or rain or a significant change of weather such as the end of a drought, since angular variations are possible at such times.
62. Aerodrome Operators (AOs) **should** ensure that PAPI checks are completed:
- a. On commissioning.
 - b. Following temporary removal of a system.
 - c. Following the completion of a Runway refurbishment where flying has ceased and construction traffic may have caused the misalignment of the PAPI units.

**Acceptable
Means of
Compliance
3590(7)**

63. The checks at Table 9 (Annex A) **should** be completed by an accredited flight checking unit.
64. The results of the PAPI Check **should** be recorded on the form at Table 10 (Annex A). The form **should** be retained by the Unit as part of its Defence Aerodrome Assurance Framework iaw RA 1026¹⁰.
65. The insulation resistance value of a primary series circuit may decrease by a significant amount before any operational effect on the AGL is noticed; however in this case there would be a much greater Risk of harm to Maintenance or installation persons and Risk of loss to operational capability. Maintenance Management Organizations **should** comply with the procedures and recommendations dealing with AGL circuit installation, commissioning, Maintenance and Fault finding detailed in DIO Publication: Installation, Testing, Commissioning and Maintenance of AGL Circuits; the Practitioners Guide PG 01/2008: Management of Visual Aids at Military Aerodromes; and BS EN 61821- Electrical installations for lighting and beaconing of Aerodromes: Maintenance of aeronautical ground lighting constant current series circuits.
66. A check of an alternative input supply to the AGL system (where provided) operating under full load **should** be made at least once a month. Where the alternative input power supply is provided by independent generators, they **should** be run for at least 15 minutes under full load when carrying out this check. When automatic switchover is provided a check of the switching system **should** also be made. A log **should** be maintained detailing each check undertaken with the maximum switchover times and generator running times recorded along with any action taken.
67. All visual aids equipment, installation and facilities including supporting infrastructures and facilities **should** be inspected and, where required, tested. Their conditions and performance **should** be monitored regularly as part of an Aerodrome and / or HLS preventive and corrective Maintenance programme, with the objective of achieving the high levels of reliability of visual aids to properly support Aerodrome and / or HLS operations and to maintain safety.

**Guidance
Material
3590(7)**

Maintenance - Visual Aids

68. This RA is intended to define the Maintenance performance level objectives. They are not intended to define whether the lighting system is operationally out of service.
69. The energy savings of Light Emitting Diodes (LEDs) are due in large part to the fact that they do not produce the infra-red heat signature of incandescent lamps. AOs who have come to expect the melting of ice and snow by this heat signature may wish to evaluate whether a modified Maintenance schedule is required during such conditions, or evaluate the possible operational value of installing LED fixtures with heating elements.
70. Enhanced vision systems (EVS) technology relies on the infra-red heat signature provided by incandescent lighting. An appropriate means of notifying Aerodrome and / or HLS users of EVS when lighting systems are converted to LED needs to be used.
71. With respect to barrettes, crossbars and Runway edge lights, lights are considered to be adjacent if located consecutively and:
- a. Laterally: in the same barrette or crossbar; or
 - b. Longitudinally: in the same row of edge lights or barrettes.
72. In barrettes and crossbars, guidance is not lost by having two adjacent unserviceable lights.
73. The Maintenance of AGL equipment needs to consider the objectives of Aerodrome and / or HLS operations and address the impact on such operations whilst Maintenance activities are being performed. In addition, during periods of

¹⁰ Refer to RA 1026 – Aerodrome Operator and Aerodrome Supervisor (Recreational Flying) Roles and Responsibilities .

**Guidance
Material
3590(7)**

Maintenance, or equipment failure, it may be necessary to operate AGL circuits on local control at the 'A' and / or 'B' Centres, thus removing control from ATC whilst the work is being performed. A procedure for local operation needs to be agreed with ATC before local switching of AGL circuits commences. A record of all Maintenance operations needs to be kept including periods when local operation of a circuit or 'A' and 'B' Centre is under the control of Maintenance staff. A log book needs to be provided at each 'A' and 'B' Centre for this purpose. As an aid to Maintenance each AGL location needs to be marked with an identification number legible, where practicable, from a passing vehicle (eg 27/A/14 refers to light position No 14 of circuit A on Runway 27) as follows:

- a. Short term measures for no more than 12 months may utilize:
 - (1) Lights in paved areas – Numbers painted with white road paint adjacent to the light fitting;
 - (2) Lights in grassed areas – Numbers painted on a suitable tag, plate or plinth;
 - (3) Pole or mast mounted lights – Numbers painted on plates attached to the poles or masts;
- b. The number of each position needs to be permanent, reusable and may be repositioned when required without the necessity for refurbishment. Identification of fittings, particularly inset type, needs to be considered as part of an overall Maintenance strategy and potential asset Audit system. The use of electronic tagging needs to be viewed as an innovative solution.

**Regulation
3590(8)**

Safeguarding - MOD Property

3590(8) HoEs and ADH-Facing organizations **shall** ensure that Siting Boards are held for any new installation to be built on the establishment they are responsible for.

**Acceptable
Means of
Compliance
3590(8)**

Safeguarding - MOD Property

74. At an Aerodrome and / or HLS, the AO or a nominated deputy **should** attend Siting Boards to give specialist advice and comments in relation to safeguarding criteria. The safeguarding criteria **should not** be violated except when the proposed obstacle is operationally essential and a waiver or exemption has been granted by the MAA.

75. The AO **should** ensure that the safeguarding criteria are strictly adhered to and, where appropriate, comprehensive specialist remarks are recorded in the Findings and Recommendations of Siting Boards (Form 2). Annex B of this RA contains the AO's Certificate, which **should** be completed and attached to the Form 2 following each Siting Board. Amplification of the remarks by an accurate plan of the proposed siting area, together with all relevant dimensions, **should** be included as an Annex to the Findings of the Siting Board.

76. Any paperwork associated with Aerodrome and / or HLS Siting Boards for obstacles / buildings, which could affect Aerodrome and / or HLS design and safeguarding standards, **should** be retained indefinitely or until the obstacle / building is removed.

**Guidance
Material
3590(8)**

Safeguarding - MOD Property

77. Safeguarding criteria includes considering the potential to increase the wildlife strike Risk.

**Regulation
3590(9)**

Safeguarding - Outside MOD Property

3590(9) DIO Assistant Head - Estates-Safeguarding **shall** publish an official safeguarding map (Official Safeguarding Plan) which is issued to County and Local Planning Authorities and to certain other bodies.

**Acceptable
Means of
Compliance
3590(9)**

Safeguarding - Outside MOD Property

78. For statutory safeguarding map production purposes:

- a. Aerodrome codes **should** be determined from the length of the Runway only. Width and Runway letters **should not** be used. Where more than one Runway exists the most stringent code **should** be used for all Runways.
- b. Threshold, Runway end and clearway locations and heights **should** be taken from the latest Measured Heights Survey available.

**Guidance
Material
3590(9)**

Safeguarding - Outside MOD Property

79. The requirement to identify the standard / criteria needed to safeguard an Aerodrome, and when a safeguarding plan needs to be produced / replaced, resides with the Top Level Budget (TLB) / operating authority.

80. The planning and other relevant development control processes in place in England, Scotland and Wales make provision for the Secretary of State to issue official Aerodrome safeguarding plans upon which planning (and other relevant consenting authorities) are obliged to consult the MOD on relevant development proposals which might prejudice their actual or potential use for aviation purposes. The MOD publishes an official safeguarding map which is issued to County and Local Planning Authorities and to certain other bodies. MOD Aerodromes are also issued with copies of the map, through the DIO.

81. The Statutory safeguarding map is colour coded into sections for which different reference heights are given. These are the heights above which new construction, on and near an Aerodrome, may interfere with flying activity. Planning Authorities are required to consult the DIO (Safeguarding) about any application they receive for any development exceeding the appropriate reference level. The area covered by the map depends upon the length of the longest safeguarded Runway, either existing or planned. Other factors are incorporated iaw the obstruction limitation criteria given in RA 3512¹¹ and RA 3532¹². Account is also taken of the need to protect instrument approach procedures and radio and radar aids, some of which cannot be utilized satisfactorily unless stringent rules are observed to protect the operating environment.

82. Instrument approach and departure criteria, as laid down in ICAO Procedures for Air Navigation - Operations (PANS-Ops) are unlikely to be infringed by obstacles that do not violate safeguarding criteria. If, when considering the implication of obstacles, doubt exists about their effect on instrument approach and departure criteria advice may be sought from SO3 AIM No 1 AIDU, RAF Northolt.

**Regulation
3590(10)**

Safeguarding - Surface Obstructions

3590(10) HoEs and ADH-Facing organizations **shall** ensure that any obstacle which projects above the surface of an Aircraft movement area and its associated shoulder and Runway / taxiway strip, and therefore constitutes an obstacle hazardous to Aircraft, **shall** be removed.

¹¹ Refer to RA 3512 – Permanent Fixed Wing Aerodrome - Obstacle Environment.

¹² Refer to RA 3532 – Helicopter Landing Site - Obstacle Environment.

**Acceptable
Means of
Compliance
3590(10)**

Safeguarding - Surface Obstructions

83. Obstacles **should not** be permitted on Runways, taxiways or Aprons. Frangible elevated light fittings and Airfield reflective markers **should** be sufficiently low to preserve clearance for propellers and for the engine pods of jet Aircraft.
84. Shoulders **should** be obstacle free, except when impossible for operational reasons.
85. Runway and Taxiway Strips **should** be free of obstacles.
86. Runway End Safety Areas **should** be free of obstacles.
87. Stop ways. The only obstacles permitted in stopways **should** be approach lights, of a lightweight construction, frangibly mounted and not exceeding 0.46 m in height.
88. Clearways. Any obstacle that has to be located in the clearway **should not** penetrate the prescribed clearway gradient. Any obstacle which does penetrate this gradient will define the end of the clearway.
89. Overlapping Areas. Where 2 or more areas overlap, eg clearway overlapping stopway, the more stringent obstacle limitation **should** apply.
90. ATC Tower Visibility. The Visual Control Room (VCR) **should** be suitably positioned, elevated and safeguarded to provide the maximum visibility of the Aircraft manoeuvring area, with an absolute minimum visibility requirement considered as a clear and uninterrupted view of all Runways, thresholds, approach paths and circuit patterns.
91. Objects **should not** penetrate the Obstacle Limitation Surfaces iaw RA 3512¹¹.

**Guidance
Material
3590(10)**

Safeguarding - Surface Obstructions

92. The VCR will ideally be provided with the maximum possible uninterrupted view of all taxiways, Aprons and dispersal areas.
93. Guidance on the frangible design of visual and non-visual aids for navigation is given in the ICAO Aerodrome Design Manual (Doc 9157), Part 6.

**Regulation
3590(11)**

Safeguarding - Sub-Surface Obstructions

- 3590(11) HoEs and ADH-Facing organizations **shall** ensure that where sub-surface structures cannot be dispensed with, they are constructed so that they present the minimum practical vertical face to undercarriage wheels, if necessary, by the provision of sub-surface ramps.

**Acceptable
Means of
Compliance
3590(11)**

Safeguarding - Sub-Surface Obstructions

94. Any structure which lies within 300 mm of the surface or is flush with the surface of the unpaved parts of the movement areas, shoulders or Runway strips may be hazardous to an Aircraft which runs off the paved surface. Such potential Hazards **should** be kept to a minimum by critically examining each stated need in the first instance and by ensuring that any existing obstructions continue to meet an essential function.

**Guidance
Material
3590(11)**

Safeguarding - Sub-Surface Obstructions

95. Sub-surface obstructions may include holes, trenches etc.

**Regulation
3590(12)****Safeguarding - Operationally Essential Obstructions**

3590(12) HoEs and ADH-Facing organizations **shall** ensure that Operationally Essential Obstructions are sited iaw correct procedures and are treated as Hazards where appropriate.

**Acceptable
Means of
Compliance
3590(12)****Safeguarding - Operationally Essential Obstructions**

96. Each Aerodrome and / or HLS **should** have the appropriate Siting Board paperwork in place for operationally essential obstructions, and each item **should** be recorded within the appropriate Risk Register / Hazard Log.

97. The distance of operationally essential obstructions from the Runway or taxiway centre-line **should** be the maximum, and their height the minimum, commensurate with their function and provision of safe passage to Aircraft taxiing whilst keeping all wheels on the paved surface.

**Guidance
Material
3590(12)****Safeguarding - Operationally Essential Obstructions**

98. Operationally Essential Obstructions are defined as objects which:

- a. Are essential for the safe operation of the Aerodrome and / or HLS.
- b. Need to be sited in a specific location in order to carry out their function.
- c. Penetrate one or more protected surfaces.

99. The following items may be considered examples of operationally essential equipment:

- a. Runway Caravan.
- b. Arrestor Equipment including Barrier and Rotary Hydraulic Arrestor Gear (RHAG) installations.
- c. RVR Towers.
- d. Illuminated Runway Distance Marking Signs.
- e. Precision Approach Radar (PAR) and Instrument Landing System (ILS) installations.
- f. Instrumented RVR (IRVR) equipment.

100. The MAA may offer guidance on any additional items considered to be operationally essential.

Annex A

Maintenance and Safeguarding

Table 1. Friction Survey Requirements

| Item | Friction Survey Type | | |
|--|--|---|------------------------------------|
| | Monitoring ^a | Special | Classification |
| Programme | | | MOD Specialists |
| Frequency | 6 monthly or ► more frequently ◀ at SATCO discretion. | As required by MOD specialists, Relevant Military Authority or Station. | ≤ 4 yearly ^c |
| Survey notification | | | Calling notice by MOD specialists. |
| Survey timing | | By arrangement by an MOD Specialist. | |
| Survey duration | | 1-2 days depending on survey scope, weather and availability of water. | |
| Conducted by | Station | MOD specialists Term Contractor. | |
| Measuring speed | 65 km / h ^b | | 65/80/95 km / h ^b |
| Survey validity | If the maximum absolute difference between the average friction values for any two check runs is greater than 0.06 the entire survey is invalid. | | |
| Results reporting format | As per Table 4 | As per Table 3 | |
| Results Reporting / Evaluation | To Relevant Military Authority. | MOD specialists Term Contractor to MOD specialists and onward to Relevant Military Authority and Station. | |
| Equipment calibration / usage | law relevant Service Operator's Manual. | | |
| Results retention | Until next classification Survey. | | |
| Survey funding | Station ^{de} | | |
| ^a There is no correlation between monitoring and classification survey results. ^b For straight runs only. MOD specialists can advise on test methods for curved or restricted areas. ^c See Table 5 for variations. ^d Except for survey prior to handover of new / reconstructed pavements – paid for by Project. ^e Additional costs caused by Station imposed restricted access to pavements during survey fall to Station. | | | |

Table 2. Runway Friction Classification / Monitoring Survey Procedures

| Item | Criteria | |
|----------------------------------|---|--|
| | Classification Survey | Monitoring Survey |
| Equipment | Mk 6 Mu-Meter, or other MOD specialists approved equipment | |
| Equipment calibration interval | a. Before every survey. | a. ≤12 months. b. iaw manufacturer's instructions. c. Results to be retained. |
| Operator | DIO Term Contractor approved person | Authorized ATC Personnel |
| Team Size | ≥ 2 people (Driver and recorder) | |
| Recording medium | Purpose designed software with instant Visual Display Unit (VDU) and hard-copy read out together with database recording capability | |
| Pavement surface conditions | a. Dry before and during survey. b. Conditions and changes in condition to be recorded. | a. Natural rain or in detrimental to Aircraft movement conditions. b. Conditions and changes in condition to be recorded. |
| Met conditions | Ambient air temperature ≥ 2°C | |
| Aircraft arrestor systems | De-rigged | |
| Procedure | Method / Criteria | |
| Establish run and start position | a. See Figure 1 which shows the stationary vehicle start position. b. Enables location of data relative to Runway threshold lights to be determined ^a . c. Mark on pavement and record position. | |
| Conduct runs | a. iaw Table 3 for Classification Surveys and Table 4 for Monitoring Surveys. b. 1 st run starts from Runway end with the higher QDM. | |
| Water Depth | 1 mm | Natural wet conditions |
| Speed | As given in Table 3 ± 5 km / h | 65km / h ± 5 km / h |
| Run track separation | a. 3 m. b. Start 1.5 m from Runway centre-line. | |
| Track tolerance | ±1m | |
| Check runs | a. Runs 1, 11 and 17. b. Run 1 taken @ 3 m from Runway edge. c. Runs to be consistently wet or dry throughout. d. All runs in the same direction. | a. Runs 7 and 8. b. All runs in the same direction. |
| Check run 10 | a. Self-wetted. b. 1.5 m from Runway centre-line. | |
| Speed runs 2,3,8 and 9 | a. To establish speed friction curve. b. Self-wetted. c. Each run to traverse the same track in the same direction. d. Located outside area of rubber deposits but ≤ 15 m either side of Runway centre-line. | |
| Standard Runs ^b | a. Self-wetted. b. Start run 4 @ 1.5 m from Runway centre-line. c. Subsequent runs @ 3 m spacing out to 19.5 m. | a. Runs 1-6. b. Surface soaked but no standing water. |
| Reports | In accordance with RA 3590(2) AMC Para 12 and Annex A Tables 3, 4, 6 and 7 as applicable. | |
| | ^a Distances before the threshold in the landing direction will be negative see Figure 1. | |
| | ^b Known as wet runs for monitoring survey. | |

Figure 1 Runs Start With Stationary Friction Machine Measuring Wheel/s 10 m from Pavement End

Table 3. Runway Friction Classification Survey Run Sequence and Results

| Aerodrome | | Runway | | | | | Date | | | | | |
|-----------------|----------|---------------------------|--------------------------------------|----------------------------------|----------------|------------------------|-------------|--------------------------------|--------------------------|---------|---------|--|
| Run No | Run Type | Run Direction (Start QDM) | Distance from Runway Centre-line (m) | Side of Centre-line ^b | Speed (km / h) | Self-Wetting ON / OFF | Water Depth | Surface Condition ^g | Surface Temperature (°C) | Results | Remarks | |
| 1 ⁱ | Check | Hi | 3.0 ^a | L / R ^d | 65 | On / Off ^{cd} | Dry or Wet | | | | | |
| 2 | Speed | Lo | 13.5 | R | 80 | On | 1 mm | | | | | |
| 3 | Speed | Hi | 10.5 | R | 95 | On | 1 mm | | | | | |
| 4 | Standard | Lo | 1.5 | R | 65 | On | 1 mm | | | | | |
| 5 | Standard | Hi | 4.5 | L | 65 | On | 1 mm | | | | | |
| 6 | Standard | Lo | 1.5 | L | 65 | On | 1 mm | | | | | |
| 7 | Standard | Hi | 4.5 | R | 65 | On | 1 mm | | | | | |
| 8 | Speed | Lo | 13.5 | R | 95 | On | 1 mm | | | | | |
| 9 | Speed | Hi | 10.5 | R | 80 | On | 1 mm | | | | | |
| 10 | Check | Lo | 1.5 | R | 65 | On | 1 mm | | | | | |
| 11 | Check | Hi | 3.0 ^a | L / R ^d | 65 | On / Off ^{cd} | Dry or Wet | | | | | |
| 12 | Standard | Lo | 7.5 | R | 65 | On | 1 mm | | | | | |
| 13 | Standard | Hi | 10.5 | L | 65 | On | 1 mm | | | | | |
| 14 | Standard | Lo | 7.5 | L | 65 | On | 1 mm | | | | | |
| 15 | Standard | Hi | 10.5 | R | 65 | On | 1 mm | | | | | |
| 16 | Standard | Lo | 13.5 | R | 65 | On | 1 mm | | | | | |
| 17 | Check | Hi | 3.0 ^a | L / R ^d | 65 | On / Off ^{cd} | Dry or Wet | | | | | |
| 18 | Standard | Lo | 13.5 | L | 65 | On | 1 mm | | | | | |
| 19 ^e | Standard | Hi | 16.5 | R | 65 | On | 1 mm | | | | | |
| 20 ^e | Standard | Lo | 19.5 | L | 65 | On | 1 mm | | | | | |

| | | | | | | | | | | | | |
|-----------------|--|----------|----|------|---|----|----|--------|--|--|--|--|
| 21 ^e | | Standard | Hi | 16.5 | L | 65 | On | 1 mm | | | | |
| 22 ^e | | Standard | Lo | 19.5 | R | 65 | On | 1 mm | | | | |
| 23 | | Standard | Hi | 10.5 | L | 65 | On | 0.5 mm | | | | |
| 24 | | Standard | Lo | 13.5 | L | 65 | On | 0.5 mm | | | | |

^a From Runway edge.
^b Side is taken relative to the Centre-line in the direction of travel, run specific.
^c To be consistent throughout runs 1, 11 and 17.
^d Delete as required.
^e For narrow Runways ignore runs 19-22.
^f Run 1 must start from the higher QDM.
^g In accordance with Table 8 Classification of Surface Conditions.

Table 4. Runway Friction Monitoring Survey Run Sequence and Results

| Aerodrome | | | | | | | | Runway | | | | Date | |
|-----------|------|----------|---------------------------|--------------------------------------|----------------------------------|----------------|--------------------------------|--------------------------|--|---------|--------|---------|--|
| Run No | Time | Run Type | Run Direction (Start QDM) | Distance from Runway Centre-line (m) | Side of Centre-line ^b | Speed (km / h) | Surface Condition ^d | Surface Temperature (°C) | Average Friction Value (relative to Hi QDM / Centre/Lo QDM 1/3 portions of Runway) | | | Remarks | |
| | | | | | | | | | Lo 'A' | Ctr 'B' | Hi 'C' | | |
| 1 | | Wet | Hi | 10.5 | R | 65 | | | | | | | |
| 2 | | Wet | Lo | 1.5 | L | 65 | | | | | | | |
| 3 | | Wet | Hi | 10.5 | L | 65 | | | | | | | |
| 4 | | Wet | Lo | 1.5 | R | 65 | | | | | | | |
| 5 | | Wet | Hi | 3.0 ^a | R | 65 | | | | | | | |
| 6 | | Wet | Lo | 3.0 ^a | R | 65 | | | | | | | |
| 7 | | Check | Lo | 1.5 | L ^c | 65 | | | | | | | |
| 8 | | Check | Lo | 1.5 | R ^c | 65 | | | | | | | |

^a From Runway edge.
^b Relative to the Centre-line in the direction of travel, run specific.
^c **Should** be from the lower to the higher QDM.
^d In accordance with Table 8 Classification of Surface Conditions.

Table 5. Pavement^a Classification Friction Table for the 65 km / h Self Wetting Test

| Device | MPL ^b | MFL | Water Depth (mm) | Speed (km / h) | Tyre Pressure (kPa) | Tyre |
|--------------|-------------------|-------------------|------------------|----------------|---------------------|-------------|
| Mu-Meter Mk6 | 0.55 ^c | 0.50 ^c | 1.0 ±0.025 | 65 ± 5 | 70 ± 3.5 | ASTM E-1551 |

^a Primarily for Runways. Seek MOD specialist advice for friction concerns with other operating surfaces.
^b When calculated pavement friction levels are at or below the MPL, the periodicity of classification surveys may increase in frequency to ≤ annually.
^c Levels are for Runway markings as well as pavements. Seek MOD specialist advice for friction concerns.

Table 6. Runway Friction Survey Report

| | |
|---|--|
| Survey Type | |
| Friction Machine Type | |
| Friction Machine Serial No. | |
| Distance Per Reading | |
| Station | |
| Runway | |
| Date Of Survey | |
| Contractor | |
| Operators | |
| Tyre Serial No(s). | |
| Calculated Water Depth | |
| Air Temperature (°C) | |
| Weather | |
| Rubber Deposits | |
| Remarks | |
| | |
| Offset distance from threshold end 1 (m) | |
| Offset distance from threshold end 2 (m) | |
| Mu-Meter friction board Ser No | |
| No of passes over Mu-Meter friction board to date | |
| Confirm correct Mu-Meter calibration before survey | |
| Confirm correct Mu-Meter tyre pressures before survey | |
| a Classification Survey only | |

Table 7. Classification of Rubber Deposits

| Description of Rubber Covering Pavement Texture in Touchdown Zone - Central 18m | Classification of Rubber Deposit |
|---|----------------------------------|
| No tyre tracks. | None |
| Intermittent individual tyre tracks. | Very light |
| Individual tyre tracks begin to overlap. | Light |
| Up to 60% surface texture exposed. | Medium |
| Rubber bonded to pavement surface: less than 40% of surface, texture exposed. | Heavy |

Table 8. Classification of Surface Conditions

| Descriptor | Observation |
|---------------|---|
| Damp | The surface shows a change of colour due to moisture. |
| Wet | The surface is soaked but there is no standing water. |
| Water patches | Significant patches of standing water are visible. |
| Flooded | Extensive standing water is visible. |
| Dry | No visible moisture. |



Note: These descriptions **should not** be read or used in conjunction with RA 3272(2)   and Global Reporting Format.

Table 9. PAPI Flight Check Procedure

| | | |
|---|---------|---|
| Effective Range | Check 1 | At a range of approximately 7.5–9 km and height about 1500 ft QFE check the effective range. In daylight the difference between the red and white lights should be clearly discernible at a minimum of 7.5 km in good visibility. |
| Colour Change | Check 2 | Commence an approach from 7.5 km flying level at 1000 ft QFE and check that the units are evenly illuminated and that signal changes from red to white are sharp. Check also that the colour change sequence is even. Where PAPI is on both sides of the Runway check that the colour change of corresponding opposite units is coincident. Note: In reduced visibility it may be necessary to carry out this check at closer range in which case the height will have to be reduced. The minimum practicable height is 500 ft. |
| | Check 3 | Commence an approach from about 5 km and acquire an on-slope signal. Continue the approach, descend until 4 reds (or 2 reds in the case of APAPI are just visible. Then climb until 4 whites (or 2 whites) are visible. Return to on-slope and continue to a point close to the threshold. The colour changes should be consistent with change in height and permit easy correction of approach height and angle. |
| Luminous Intensity Settings | Check 4 | Make a normal approach from approximately 7.5 km starting at about 1000 ft QFE. Maintain an 'on-slope' indication and during the approach call for progressive reductions in intensity of the units. |
| Compatibility with non-visual aids | Check 5 | Where an instrument glidepath is available carry out an instrument approach maintaining the glidepath, or in the case of a radar approach, following ATC instructions. Check that the PAPI indicates 'on-slope' from a range of 7.5 km to close in to the threshold. The ILS glidepath should be near the lower limit of the PAPI 'on-slope' signal if an aeroplane with a small eye-to-aerial height is used. The person inspecting the system should carry a diagram of the installation to facilitate recording any observed deficiencies. |
| Obstacle check | Check 6 | Fly sufficiently low from 7.5 km so as to be just within the all-red indication and check that there is clearance from obstacles throughout the horizontal coverage of the beam. |

Table 10. PAPI Flight Check Form

| PAPI Flight Check | | Aerodrome: | | | |
|---|------|---------------------|---|---|--|
| Runway Designation | | | | | |
| Effective Range (KM) | | | | | |
| Colour Change : Red-to-White (Level run 1000 ft QFE from 7.5 km) | | | | | |
| Intensity Balance of individual Units (and of Left and Right sides if applicable) | | | | | |
| Intensity Check | 100% | | | | |
| | 80% | | | | |
| | 30% | | | | |
| | 10% | | | | |
| | 3% | | | | |
| | 1% | | | | |
| | <1% | | | | |
| Integration with non-visual aids | | | | | |
| Synchronisation Left – Right (If applicable) | | | | | |
| Obstacle Clearance | | | | | |
| Fitting Type | | | | | |
| Date: | | Day / Dusk / Night: | | | |
| Time: | | Weather: | | | |
| Aircraft Registration: | | Visibility: | | | |
| Captain: | | Cloud: | | | |
| | | Turbulence: | | | |
| Notes: | | | | | |
| | | L | | R | |
| | 1 | 2 | 3 | 4 | |
| | 0 | 0 | 0 | 0 | |
| 1 | 1 | | | | |
| 2 | 2 | | | | |
| 3 | 3 | | | | |
| 4 | 4 | | | | |
| Additional Notes: | | | | | |
| Inspected by: | | | | | |

Annex B

Aerodrome Operator's Certificate

- 1. The following Aerodrome Operator's Certificate is given iaw the requirements of the RA 3500 Series.
 - a. Proposed facility:
 - b. Reference:

Certificate by Unit

- 2. I certify that:
 - a. *The proposed facility will not infringe any Runway, taxiway or Aircraft Servicing Platform (ASP) / Operational Readiness Platform (ORP) strips.
 - b. *The proposed facility will not infringe any Obstacle Limitation Surface
 - c. *The proposed facility will infringe the safeguarding criteria for the movement area or Aerodrome / HLS environment and I have the following comments:

*(delete as appropriate)

Date.....Signature.....Name.....

Appointment.....Rank.....

Comments by HQ AIR / NCHQ / HQ Land / MOD DE&S

- 3. We have seen the plans for the proposed facility and have the following comments:

Date.....Signature.....Name.....

Appointment.....Rank.....

Intentionally Blank for Print Pagination