

Decommissioning Programmes for Chestnut Field Phase 2

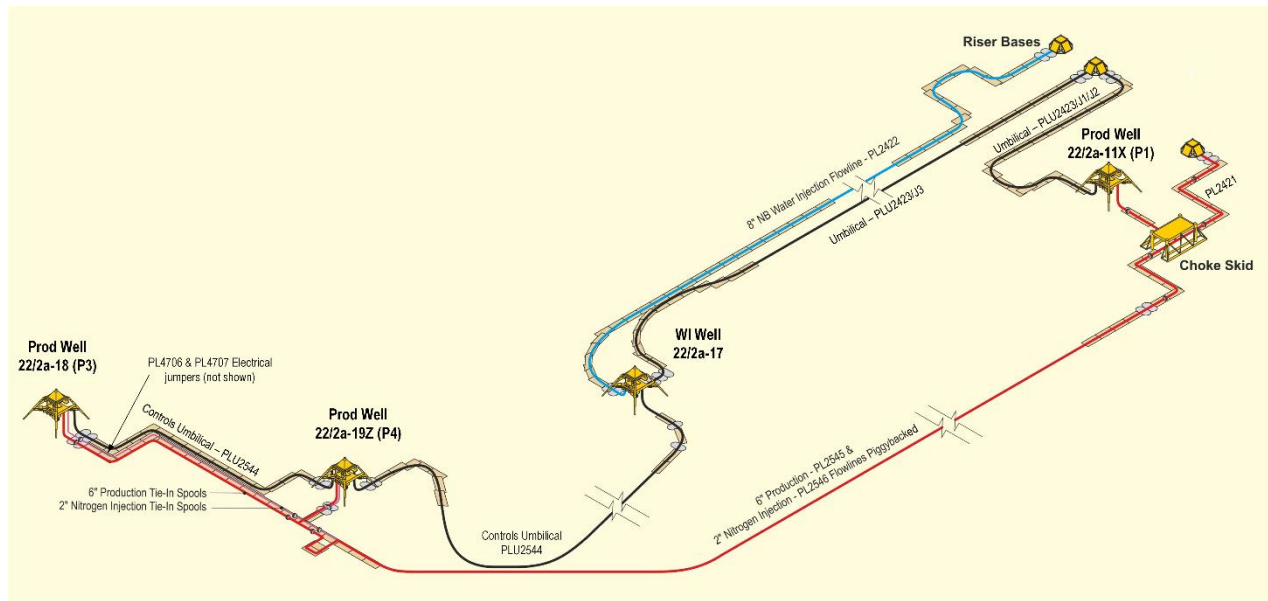

FINAL Version 07 March 2023

DOCUMENT CONTROL

Document ID:		CHESDC-SPT-Z-0000-PRG-0002	
Document Classification:		PUBLIC	
Document Ownership:		Decommissioning	
Date of Document:	08 May 2021	Signature	Date
Prepared by:	S. Axon	<i>S. Axon</i>	07/03/22
Reviewed by:	J. Mitchell	<i>J. Mitchell</i>	07/03/22
Approved by:	D. Farrell	<i>D. Farrell</i>	07/03/22

REVISION RECORD

Revision No.	Date of Revision	Reason for Issue
A1	18/06/21	Issued for review and comment
A2	16/12/21	Issued to OPRED for comment
A3	28/10/22	Issued for Statutory Consultation
C1	07/03/23	FINAL Version

DISTRIBUTION LIST

Company	No. of copies
Offshore Petroleum Regulator for Environment and Decommissioning	1 electronic
GMG, NFFO, NIFPO, SFF	1 electronic
Partners, etc.	1 electronic

<u>TABLE OF CONTENTS</u>		<u>INST</u>	<u>P/L</u>
1.	Executive Summary -----	7	✓
1.1	Combined Decommissioning Programmes	7	✓
1.2	Introduction	7	✓
1.3	Overview.....	8	✓
1.4	Summary of Proposed Decommissioning Programmes	9	✓
1.5	Field Locations including Field Layout and Adjacent Facilities	11	✓
1.6	Industrial Implications.....	19	✓
2.	Description of Items to Be Decommissioned -----	21	✓
2.1	Subsea Installations & Stabilisation Features.....	21	✓
2.2	Pipelines including Stabilisation Features	23	✓
2.3	Pipeline Structures	27	✓
2.4	Wells.....	28	✓
2.5	Drill Cuttings	28	✓
2.6	Inventory Estimate	28	✓
3.	Removal and Disposal Methods -----	30	✓
3.1	Subsea Installations and Associated Features.....	30	✓
3.2	Pipelines	31	✓
3.3	Wells.....	34	✓
3.4	Waste Stream Management Methods	34	✓
4.	Environmental Appraisal -----	36	✓
4.1	Environmental Sensitivities	36	✓
4.2	Potential Environmental Impacts and their Management.....	36	✓
5.	Interested Party Consultations -----	38	✓
5.1	Consultation Summary.....	38	✓
6.	Programme Management-----	40	✓
6.1	Project Management and Verification.....	40	✓
6.2	Post-Decommissioning Debris Clearance and Verification	40	✓
6.3	Schedule.....	40	✓
6.4	Costs	42	✓
6.5	Close Out.....	42	✓
6.6	Post-Decommissioning Monitoring and Evaluation.....	42	✓
7.	Supporting Documents -----	43	✓
Appendix A	Preparatory Works Request -----	44	✓
Appendix A.1	Correspondence from Spirit Energy.....	44	✓
Appendix A.2	Correspondence from OPRED	50	✓
Appendix B	Public Notice & Consultee Correspondence -----	51	✓
Appendix B.1	Public Notices	51	✓
Appendix B.2	GMG – Mr Alex Riddell.....	52	✓
Appendix B.3	NFFO – Mr Ian Rowe, via email	53	✓
Appendix B.4	NIFPO – Mr Wayne Sloan	54	✓
Appendix B.5	SFF – Mr Steven Alexander & Mr Andrew Third.....	55	✓

FIGURES AND TABLES

Figure 1.5.1: Field location in UKCS.....	11
Figure 1.5.2: Chestnut & adjacent facilities.....	12
Figure 1.5.3: Chestnut infrastructure after Hummingbird Spirit FPSO sailaway	13
Figure 1.5.4: Chestnut infrastructure remaining after departure of FPSO	14
Figure 1.5.5: Details (part) inside Well P1 500m Safety Zone after departure of FPSO	15
Figure 1.5.6: Overview of production well P4 & P3 approaches.....	15
Figure 1.5.7: Overview of production well P1 & approaches.....	16
Figure 1.5.8: Overview of water injection well approaches	17
Figure 1.5.9: Freespan rectification work on PL2422 in 2010	18
Figure 2.1.1: Well P1 WHPS	21
Figure 2.1.2: Well P1 WHPS ‘Anchortech’ piles (4x).....	22
Figure 2.1.3: Well P1 WHPS ‘Anchortech’ piles.....	22
Figure 2.6.1: Pie-Chart of estimated inventories (installations)	28
Figure 2.6.2: Pie-Chart of estimated inventories (pipelines).....	29
Figure 3.1.1: WHPS P1 indicative pile excavation requirements, sections (approx.).....	31
Figure 3.1.2: WHPS P1 indicative pile excavation requirements, plan view	31
Figure 6.3.1: Gantt Chart of project plan.....	41
Table 1.3.1: Installations Being Decommissioned.....	8
Table 1.3.2: Installation Section 29 Notice Holders Details.....	8
Table 1.3.3: Pipelines Being Decommissioned	9
Table 1.3.4: Pipelines Section 29 Notice Holders Details (excl. PL4706 & PL4707)	9
Table 1.3.5: Pipelines Section 29 Notice Holders Details (PL4706 & PL4707)	9
Table 1.4.1: Summary of Decommissioning Programmes	9
Table 1.5.1: Adjacent Facilities.....	19
Table 2.1.1: Subsea Installations and Associated Features.....	21
Table 2.2.1: Pipeline/Flowline/Umbilical Information.....	23
Table 2.2.2: Subsea Pipeline Structures & Stabilisation Features	25
Table 2.3.1: Subsea Pipeline Structures and Associated Features.....	27
Table 2.4.1: Well Information.....	28
Table 2.5.1: Chestnut Drill Cutting(s) Pile Information	28
Table 3.1.1: Subsea Installations and Associated Features.....	30
Table 3.2.2: Pipeline Decommissioning Proposals	33
Table 3.2.3: Pipeline Protection and Stabilisation Features	33
Table 3.2.4: Pipeline Structures.....	34
Table 3.3.1: Well Decommissioning	34
Table 3.4.1: Waste Stream Management Methods.....	34
Table 3.4.2: Inventory Disposition	35
Table 3.4.3: Re-use, Recycle & Disposal Aspirations for Recovered Material	35
Table 4.2.1: Key Control and Mitigation Measures	37
Table 5.1.1: Summary of Stakeholder Comments	38
Table B.1.1: Public Notices: Press & Journal & The Edinburgh Gazette (publ’d 28 Oct 2022).....	51

TABLE OF TERMS AND ABBREVIATIONS

ABBREVIATION	EXPLANATION
~	Approximately
3LPP	3-Layer Polypropylene, coating used for carbon steel pipelines and pipework
AB	Deprecated term 'Abandoned' but included in Table 2.4.1 to indicate extent to which wells have been decommissioned (Phase 1, Phase 2, etc.)
AHV	Anchor Handling Vessel
AIS	Automatic Identification System
approaches	Refer to pipelines of umbilicals as they come nearer to their destination or termination point
BLP	Britannia Bridge-linked platform controlled remotely from the Britannia platform
CATS	Central Area Transmission System
Chrysaor	Chrysaor Production (U.K.) Limited
Control Riser Base	Anchor point for the umbilical flowline riser. Connects the umbilical flowline riser and umbilical flowline
COSHH	Control of Substances Hazardous to Health
CSV	Construction Support Vessel
dia.	Diameter
DSV	Diving Support Vessel
E&P	Exploration & Production
Eltex® TUB172	Is a medium-density polyethylene copolymer designed for the extrusion of pressure pipes for gas applications
EPR	Ethylene Propylene Rubber
ERRV	Emergency Response and Rescue Vessel
EU	European Union
FPSO	Floating, Production, Storage, Offloading (Vessel)
FSU	Floating Storage Unit
GMG	Global Marine Group
Harbour Energy	Harbour Energy Plc
HSE	Health and Safety Executive
in	Inch; 25.4 millimetres
Installation	Offshore structure, typically comprising topsides and jacket, or a subsea wellhead protection structure, subsea manifold structure or an FPSO
INST	Ticked if applicable to Installations in the Table of Contents
IMO	International Maritime Organisation
Ithaca	Ithaca Energy
kg	Kilogramme
kgf	Kilogramme-force
km	Kilometre
m	Metre(s)
MARPOL	The International Convention for the Prevention of Pollution from Ships
MAT	Master Application Template
MSV	Multipurpose Support Vessel
N, S, E, W	North, South, East, West
n/a	Not Applicable
NFFO	National Federation of Fishermen's Organisations
NIFPO	Northern Ireland Fish Producers Organisation
NLB	Northern Lighthouse Board
No.	Number (used in various Tables)
NORM	Naturally Occurring Radioactive Material
NSTA	North Sea Transition Authority
OBM	Oil Based Mud
OPEP	Oil Pollution Emergency Plan
OPRED	Offshore Petroleum Regulator for Environment and Decommissioning
P1, P2, P3, P4	Production Well Identifier
P/L	Ticked if applicable to pipelines in the Table of Contents
Piggybacked	Clamped or connected to another pipeline along part or all its length
Pipeline	Rigid pipeline, flowline, or umbilical
Pipeline end	Pipeline to pipespool connection; either a flanged or welded joint
PL/PLU	Pipeline (or Umbilical) Identification numbers (UK)
PLEM	Pipeline End Manifold

ABBREVIATION	EXPLANATION
PON	Petroleum Operations Notice
PPC	Pollution Prevention Control
PPE	Personal Protective Equipment
Production Riser Base	Anchor point for the production flowline riser. Connects the production flowline riser and the production flowline
PWA	Pipeline Works Authorisation
PWR	Preparatory Works Request
ROVSV	Remotely Operated Vehicle Support Vessel
SAT	Supplementary Application Template
SDU	Subsea Distribution Unit
SENSOL	Spirit Energy North Sea Oil Limited
SFF	Scottish Fishermen's Federation
SIMOPS	Simultaneous Operations
SOPEP	Shipboard Oil Pollution Emergency Plan
Spirit Energy	Spirit Energy North Sea Oil Limited
SSV	Subsea Support Vessel
SUT	Subsea Umbilical Termination
Te	Metric Tonne (1000kgf)
Teekay	Teekay Hummingbird Production Limited owns contract with Spirit Energy for lease of the Hummingbird Spirit FPSO
TFSW	Trans Frontier Shipment of Waste
Topsides	Offshore structure typically furnished with reception and processing equipment for produced hydrocarbons, in this case an FPSO
Towhead	A towhead is a space frame that supports and protects the manifold valves, pipework and control equipment using during operation of a pipeline bundle
UK	United Kingdom
UKCS	United Kingdom Continental Shelf
UKHO	UK Hydrographic Office
WGS84	World Geodetic System 1984
WHPS	Wellhead Protection Structure
WI	Water Injection
WI Flowline Riser Base	Anchor point for the water injection flowline riser. Connects the water injection flowline riser and the water injection flowline
x	Number of (e.g., 16x = 16 in Number)

1. EXECUTIVE SUMMARY

1.1 Combined Decommissioning Programmes

This Decommissioning Programme document concerns the decommissioning of the remaining Chestnut installations and associated pipeline infrastructure. This follows the preparatory works, and the departure of the Hummingbird Spirit FPSO and associated riser systems, which are addressed in separate Decommissioning Programmes [3]:

Installations

- 4x WHPS: production wells, P1, P2/P4, P3 & water injection WHPS.

Pipelines

- 3x riser bases: controls, water injection and production riser bases.
- Production well P2/P4 choke skid.
- Production pipeline, PL2421; PL2545.
- Water injection pipeline, PL2422.
- Hydraulic, chemical, gas lift and electrical cable umbilicals, PLU2423, PLU2423/J1, PLU2423/J2 & PLU2423/J3; PLU2544.
- Nitrogen injection pipeline, PL2546.
- PL4706 & PL4707.

Although decommissioning of the installations and pipelines are treated in this document as a standalone project, on behalf of the Section 29 holders, Spirit Energy North Sea Oil Limited (Spirit Energy) will continue to explore cost saving synergies with other projects.

Installations: In accordance with the Petroleum Act 1998, Spirit Energy as operator of the Chestnut field, and on behalf of the Section 29 notice holders (Table 1.3.2), is applying to the Offshore Petroleum Regulator for Environment and Decommissioning (OPRED) to obtain approval for decommissioning the installations detailed in Section 2 of this document. Partner letters of support will be provided separately following statutory consultation.

Pipelines: In accordance with the Petroleum Act 1998, Spirit Energy as operator of the Chestnut field, and on behalf of the Section 29 notice holders (Table 1.3.4), is applying to the Offshore Petroleum Regulator for Environment and Decommissioning (OPRED) to obtain approval for decommissioning the pipelines detailed in Section 2 of this document. Partner letters of support will be provided separately following statutory consultation.

Please note the wellhead protection structure for well P1 was not installed central to tree. This means that, as part of the preparatory works before commencement of the well decommissioning activities, a work class remotely operated vehicle cannot access the valve panel on the tree. Therefore, a preparatory works request (PWR) for the removal of the upper part of the well P1 wellhead protection structure, was submitted to OPRED for approval on 19 August 2022. The PWR was approved by OPRED 20 September 2022. The correspondence relating to this is included in Appendix A.

In conjunction with public, stakeholder and regulatory consultation, the Decommissioning Programmes are submitted in compliance with national and international regulations and OPRED guidance notes. The schedule outlined in this document is for a six-year period due to begin sometime in Q2 2023.

1.2 Introduction

The Chestnut oil field is situated in block 22/2a of the United Kingdom Continental Shelf and operated by Spirit Energy North Sea Oil Limited. It is located approximately 193km East North-East of Aberdeen, in water depths of ~123m.

The field is produced via three subsea wells, supported by one subsea water injection well, tied back to a floating production, storage, and offloading (FPSO) installation – the Hummingbird Spirit - designed and built by Sevan Marine ASA. The installation was formerly known as the “Sevan Hummingbird”. The FPSO departed the field in June 2022.

The Chestnut field was developed as a single joint development and came onstream in late 2008. It has three production wells 21/2a-11X (P1), 22/2a-19Z (P4), 22/2a-18 (P3) and a water injection well 22/2a-17 which is side-tracked from 22/2a-12. Before its departure all these were tied back to the Hummingbird Spirit via flexible risers. Spirit Energy conducted well construction activities to drill and complete the Chestnut 22/2a-18 well (P3 well, located 85m from the existing (at the time) P2 well) in August 2017. Two of these production wells (P1 and P2) were drilled before the arrival of the Hummingbird, and the third production well (P3) was drilled in 2017 during the Chestnut Infill Well Project which was implemented to drain the additional areas of the reservoir. In March 2020, the P2 well was sidetracked to P4 to improve productivity.

Cessation of Production for the Chestnut Field was accepted by NSTA on 29 November 2021 and Cessation of Production took place on 31st March 2022.

The Decommissioning Programmes explain the principles of the removal activities and are supported by a comparative assessment for the pipelines [4] and an environmental appraisal [2].

1.3 Overview

1.3.1 Installations

Table 1.3.1: Installations Being Decommissioned			
Field(s):	Chestnut	Production Type	Oil
Water Depth (m)	~123m	UKCS Block	22/2a
Subsea Installation(s)		Number of Wells	
Number	Type	Platform	Subsea
4	WHPS	n/a	4
Drill Cuttings piles (m ³)		Distance to median	Distance from nearest UK coastline
n/a		36.7km	~193km ENE of Aberdeen

Table 1.3.2: Installation Section 29 Notice Holders Details		
Section 29 Notice Holder	Registration Number	License Equity Interest (%)
Atlantic Petroleum UK Limited	04395761	0%
Atlantic Petroleum North Sea Limited	06459546	0%
Spirit Energy North Sea Oil Limited	SC210361	82.206%
Centrica Resources (UK) Limited	06791610	0%
Dana Petroleum (BVUK) Limited	03337437	17.794%
Dana Petroleum (E&P) Limited	02294746	0%
GB Gas Holdings Limited	03186121	0%
Hummingbird Spirit L.L.C.	962374 (Marshall Islands)	0%
P/F Atlantic Petroleum	BR006465 (Faroe Islands)	0%

1.3.2 Pipelines

Table 1.3.3: Pipelines Being Decommissioned		
Number of Pipelines, Flowlines, Cables, Umbilicals	8 (11)	See Table 2.2.1
NOTES		
1. PWA 10-W-07 lists PLU2423, PL2423/J1, PL2423/J2 & PL2423/J3 as being part of the same umbilical with consecutive ident numbers therefore collectively these components have been counted as one pipeline. The figure in brackets counts them as individual pipelines.		

Table 1.3.4: Pipelines Section 29 Notice Holders Details (excl. PL4706 & PL4707)		
Section 29 Notice Holder	Registration Number	License Equity Interest (%)
Atlantic Petroleum UK Limited	04395761	0%
Spirit Energy North Sea Oil Limited	SC210361	82.206%
Centrica Resources (UK) Limited	06791610	0%
Dana Petroleum (BVUK) Limited	03337437	17.794%
Dana Petroleum (E&P) Limited	02294746	0%
GB Gas Holdings Limited	03186121	0%
P/F Atlantic Petroleum	BR006465 (Faroe Islands)	0%
Atlantic Petroleum North Sea Limited	06459546	0%

Table 1.3.5: Pipelines Section 29 Notice Holders Details (PL4706 & PL4707)		
Section 29 Notice Holder	Registration Number	License Equity Interest (%)
Spirit Energy North Sea Oil Limited	SC210361	82.206%
Centrica Resources (UK) Limited	06791610	0%
Dana Petroleum (BVUK) Limited	03337437	17.794%
Dana Petroleum (E&P) Limited	02294746	0%
GB Gas Holdings Limited	03186121	0%

1.4 Summary of Proposed Decommissioning Programmes

Table 1.4.1: Summary of Decommissioning Programmes	
Proposed Decommissioning Solution	Reason for Selection
1. Installations and associated features	
<p>Complete removal. The Well P1, Well P2/P4, Well P3 and Water Injection Well WHPS and associated anode skids will be fully removed and taken to shore to be dismantled and recycled unless alternative re-use options are found to be viable and more appropriate.</p> <p>The piles associated with WHPS for P1 will be cut at -1m.</p> <p>Any applications and permits required for work associated with removal of the installations will be submitted.</p>	<p>To comply with OSPAR requirements. Cutting the WHPS piles at -1m will minimise necessary impact on seabed. Allows installations to be removed and maximises opportunity for re-use or recycling of materials.</p>
2. Pipelines	
<p>Leave all buried pipelines <i>in situ</i>. All surface laid pipelines and stabilisation features to be removed except for some features associated with PL2422.</p> <p>All the pipelines associated with the Chestnut infrastructure have already been cleaned and flushed as part of the Phase 1 decommissioning activities. All the surface laid pipelines will be fully removed along with the riser bases and well P2/P4 choke skid. This will remove potential snagging hazards from the area.</p> <p>Excavated material will be backfilled to protect the cut pipeline ends, but should any difficulties be encountered, as a contingency, small quantities of deposited rock may</p>	<p>Complies with OPRED guidance notes and maximises recycling of materials.</p>

Table 1.4.1: Summary of Decommissioning Programmes

<p>be deposited over the remaining cut pipeline ends.</p> <p>All protection and stabilisation features on the approaches will be fully removed.</p> <p>If it can be demonstrated that they would not present a snagging hazard, the protection and stabilisation features (4x 6m x 3m x 0.3m concrete mattresses overlying 30x 1Te grout bags) associated with remedial works to PL2422 (between ~KP0.677 and ~KP0.701) will be left <i>in situ</i>. Otherwise, the 4x concrete mattresses will be removed to shore for recycling and replaced with deposited rock, sufficient to bury the pipeline. The quantity of rock is estimated to be ~121Te.</p> <p>Any applications and permits required for work associated with pipeline cutting and removal will be submitted.</p>	
<p>3. Pipeline structures</p>	
<p>All riser bases and choke skids will be fully removed.</p> <p>Any applications and permits required for work associated with pipeline cutting and removal will be submitted.</p>	<p>To comply with OSPAR requirements. Allows structures to be removed and maximises the opportunity for re-use or recycling of materials.</p>
<p>4. Wells</p>	
<p>The three production wells will be decommissioned to comply with HSE “Offshore Installations and Wells (Design and Construction, etc.) Regulations 1996” and in accordance with the latest version of the Oil & Gas¹ UK Well Decommissioning Guidelines using a well intervention vessel or a semi-submersible drilling rig as deemed necessary. The water injection well has already been decommissioned.</p>	<p>Meets the NSTA and HSE regulatory requirements.</p>
<p>5. Drill Cuttings</p>	
<p>The results of the Environmental Baseline Survey [1] indicate that there are no drill cuttings present.</p>	<p>n/a</p>
<p>6. Interdependencies</p>	
<p>The decommissioning works will be conducted in two phases. 1) Departure of the Hummingbird Spirit FPSO and removal of risers; 2) decommissioning of remaining installations and infrastructure. Phase 1 is dealt with under separate Decommissioning Programmes.</p> <p>The 500m safety zones of the original FPSO and well P1 overlap slightly.</p> <p>No third-party pipeline crossings will be disturbed.</p>	

¹ “Oil & Gas UK” has now been rebranded “Offshore Energy UK”

1.5 Field Locations including Field Layout and Adjacent Facilities

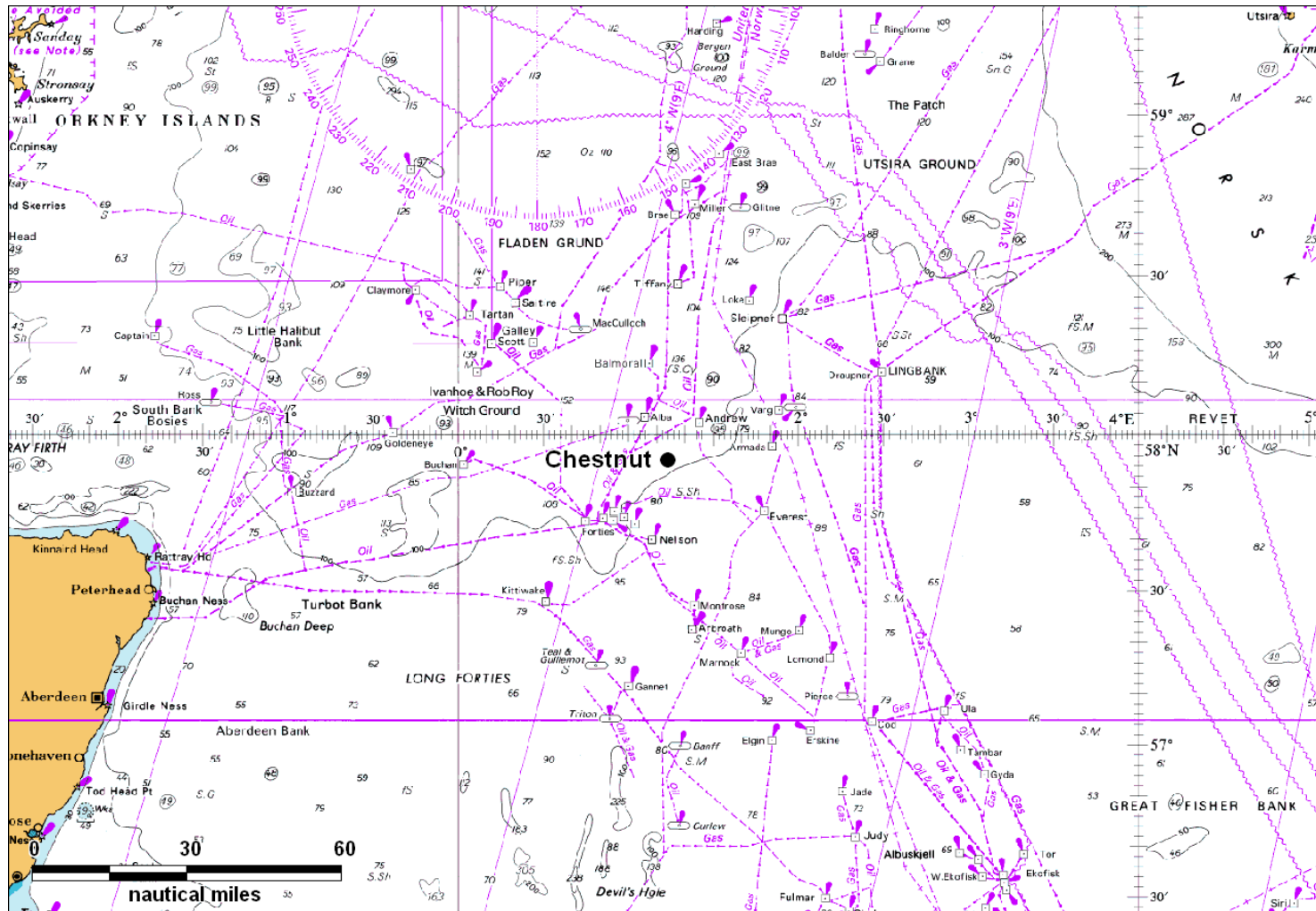

Figure 1.5.1: Field location in UKCS

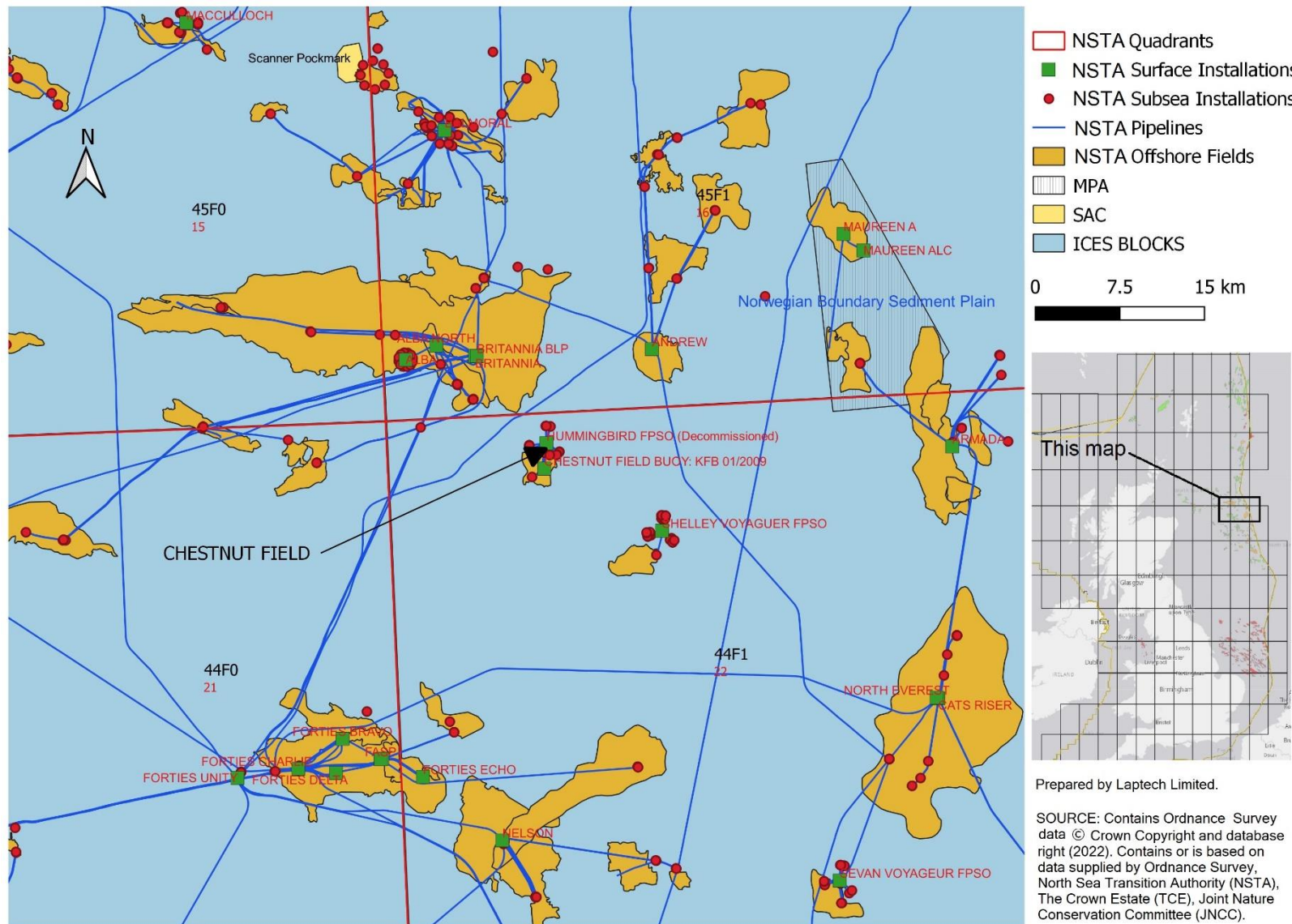

Figure 1.5.2: Chestnut & adjacent facilities

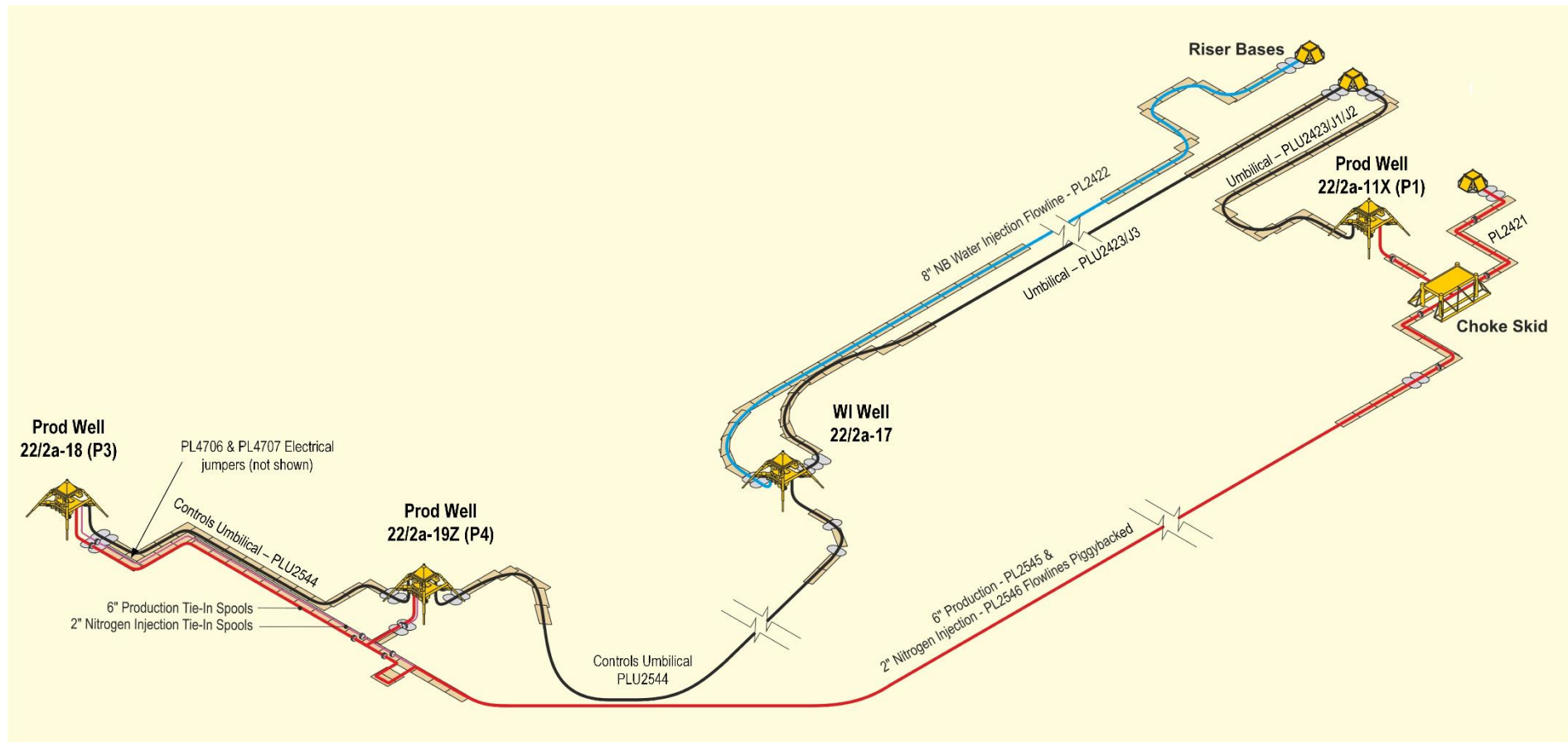

Figure 1.5.3: Chestnut infrastructure after Hummingbird Spirit FPSO sailaway

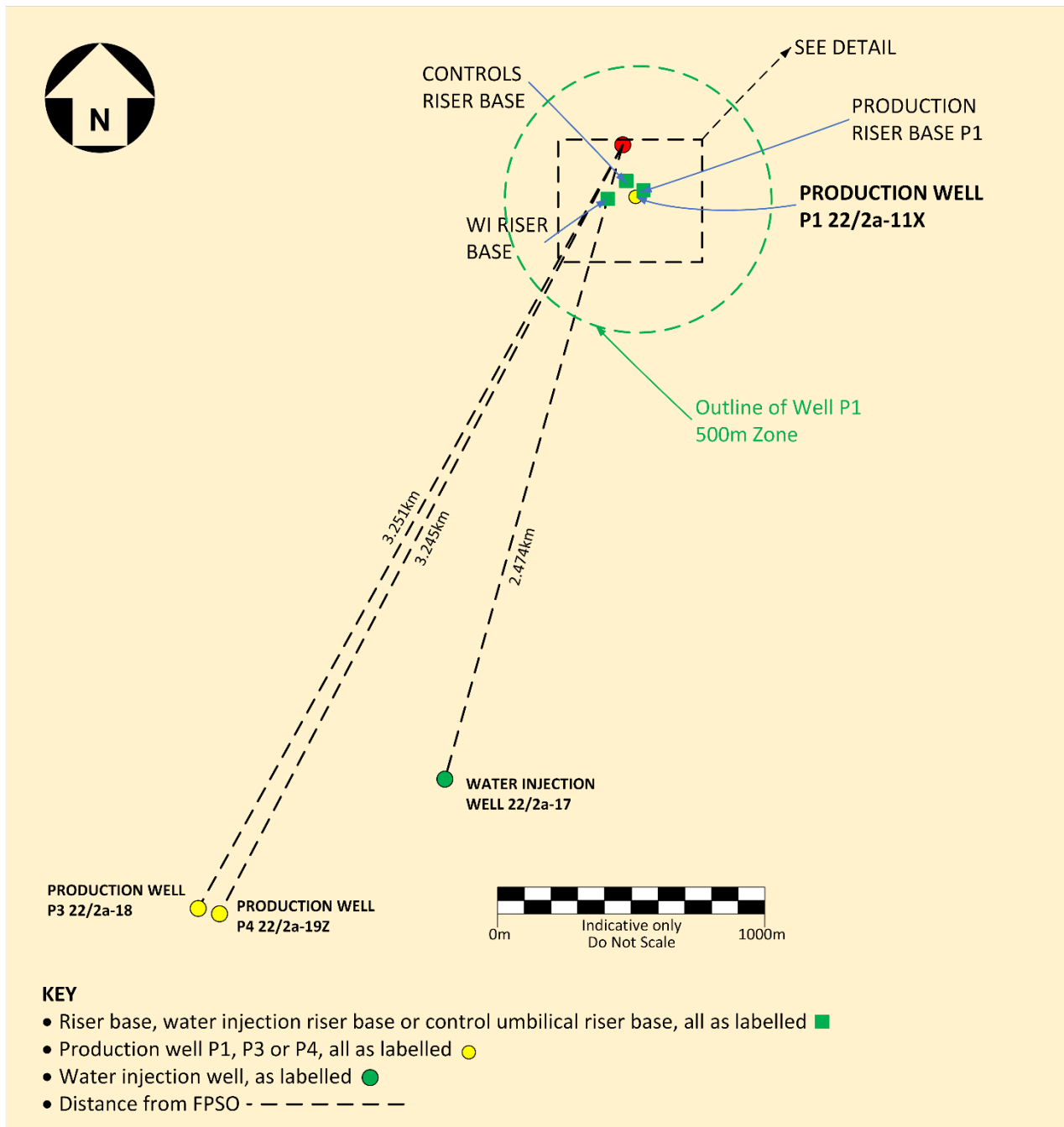

Figure 1.5.4: Chestnut infrastructure remaining after departure of FPSO

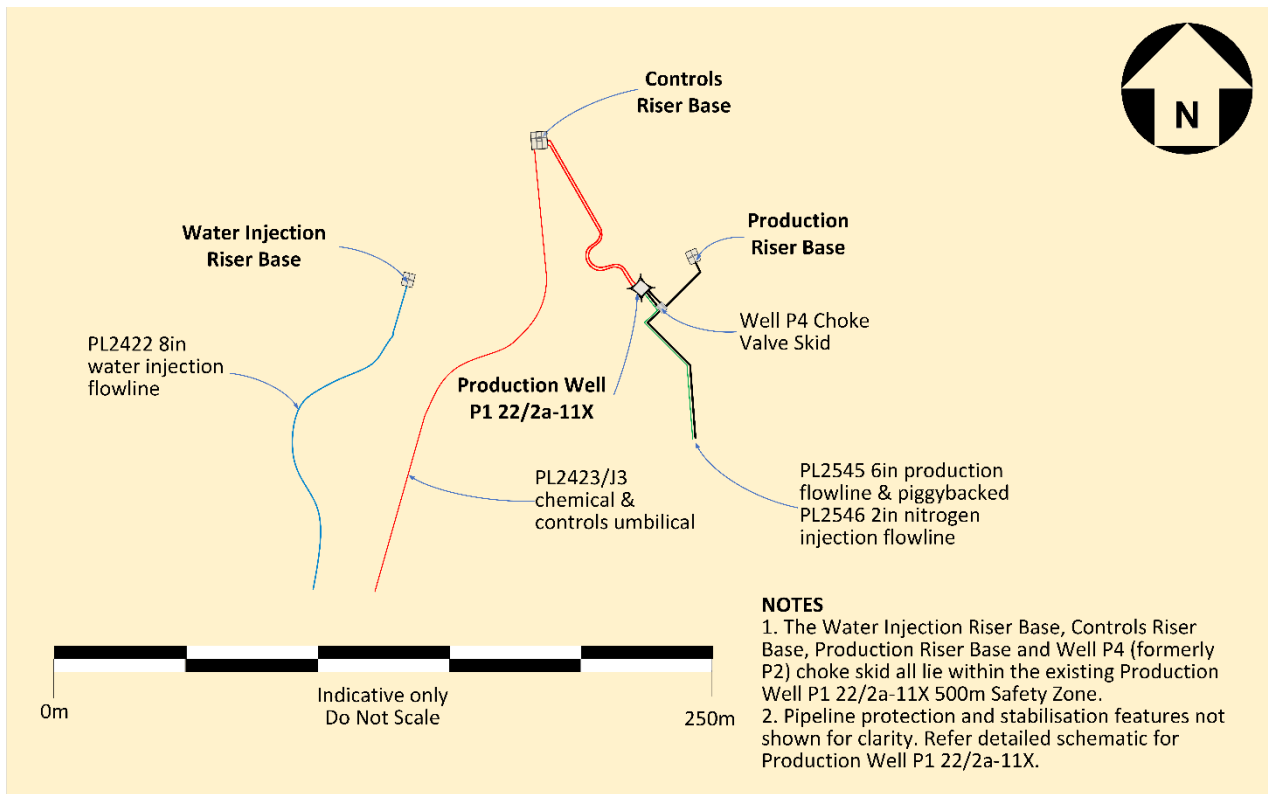

Figure 1.5.5: Details (part) inside Well P1 500m Safety Zone after departure of FPSO

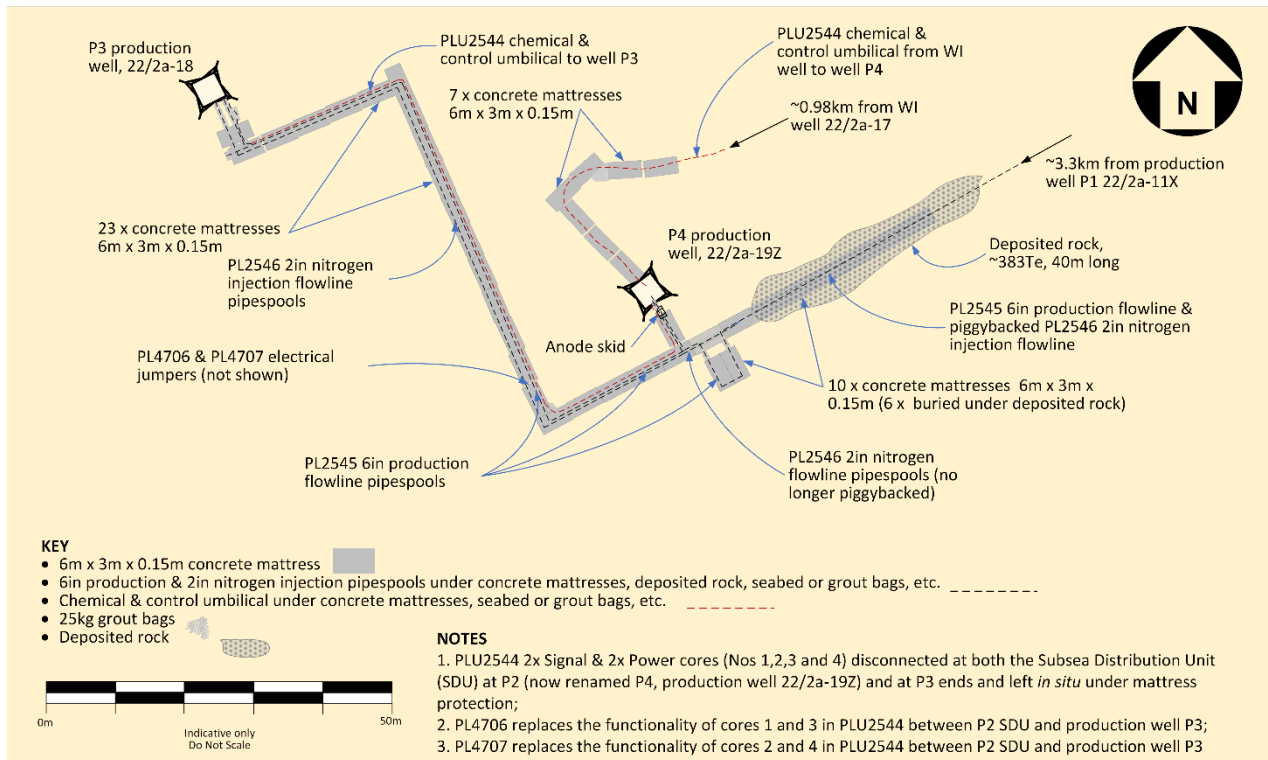

Figure 1.5.6: Overview of production well P4 & P3 approaches

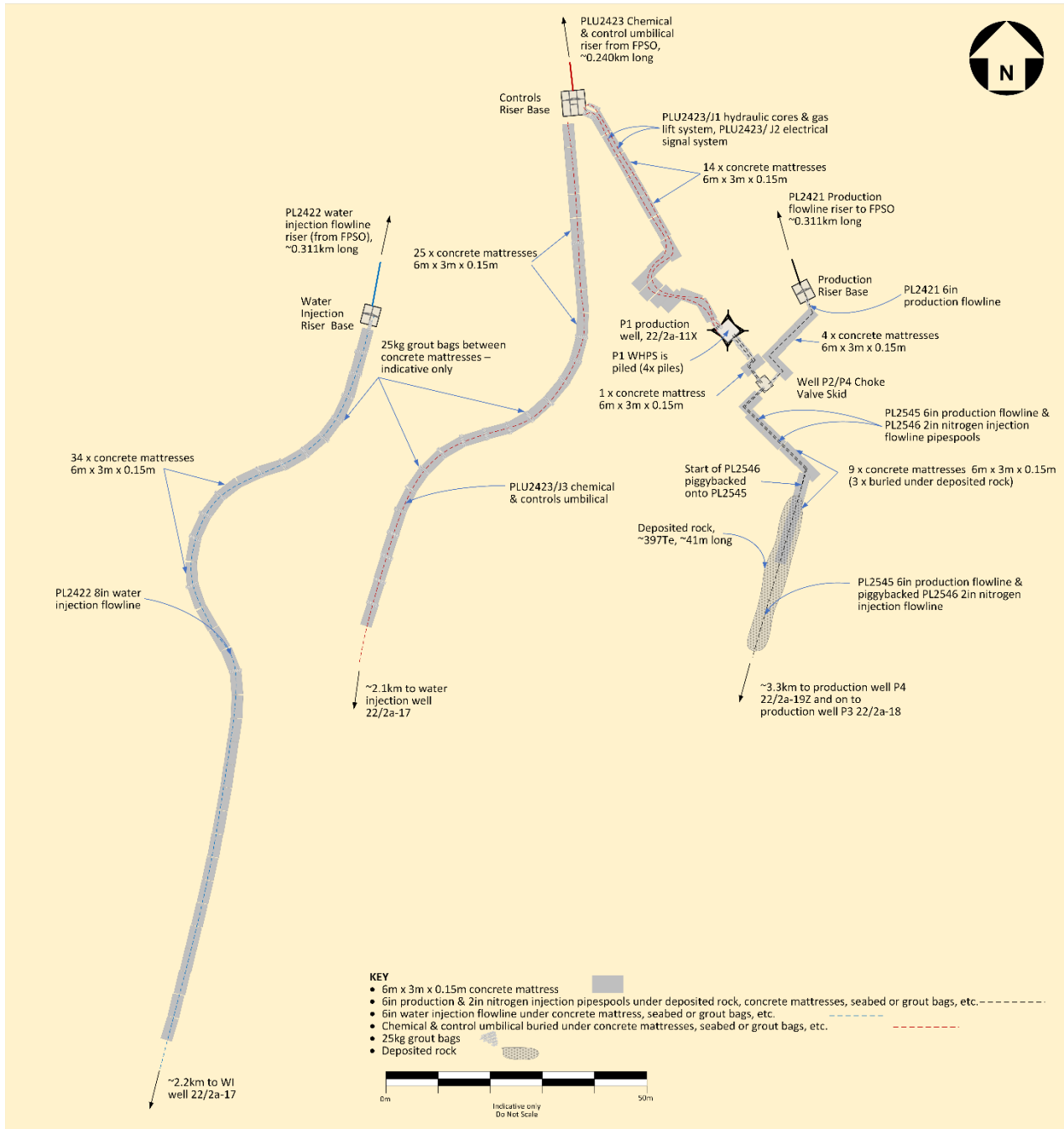

Figure 1.5.7: Overview of production well P1 & approaches

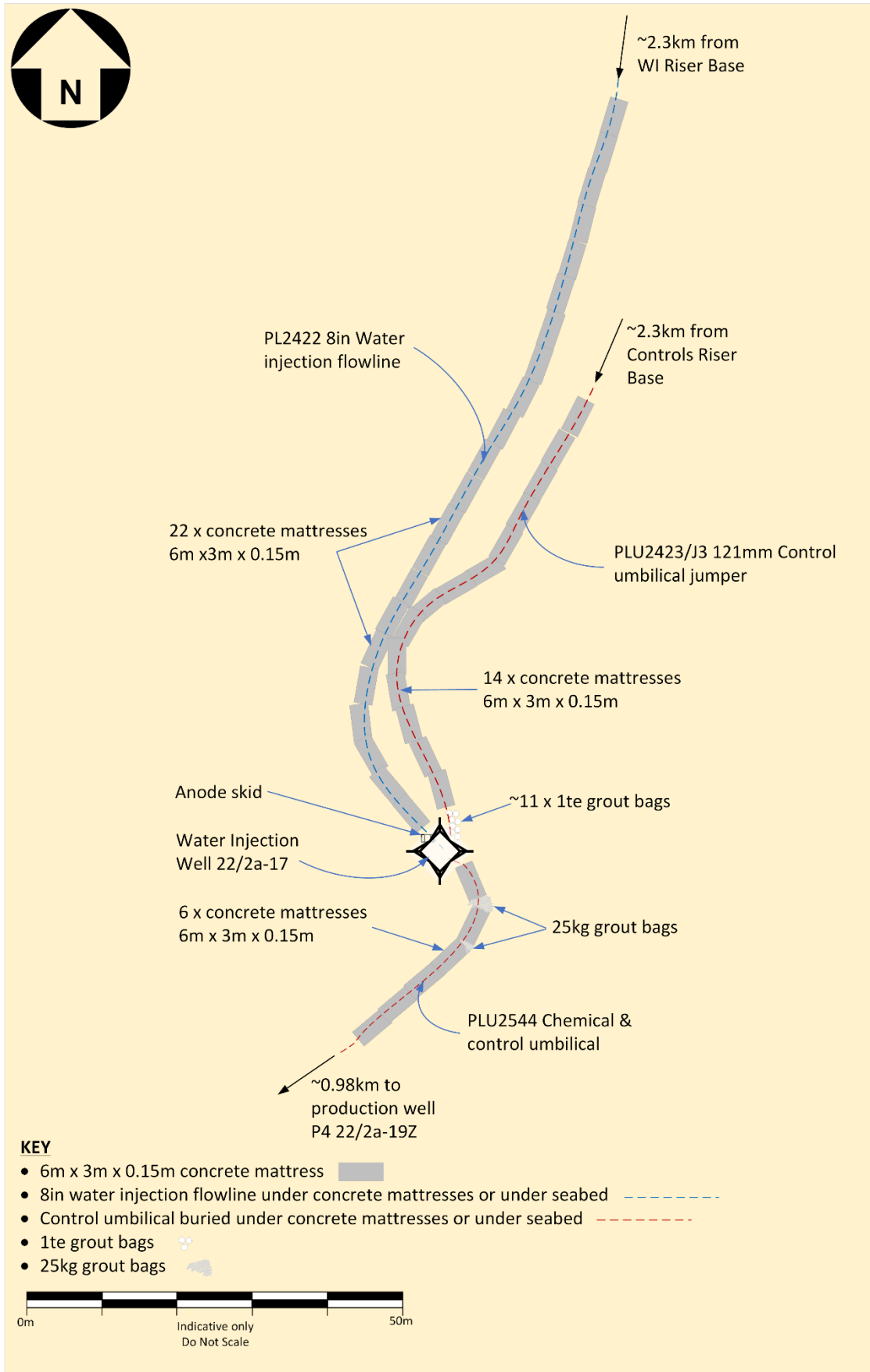

Figure 1.5.8: Overview of water injection well approaches

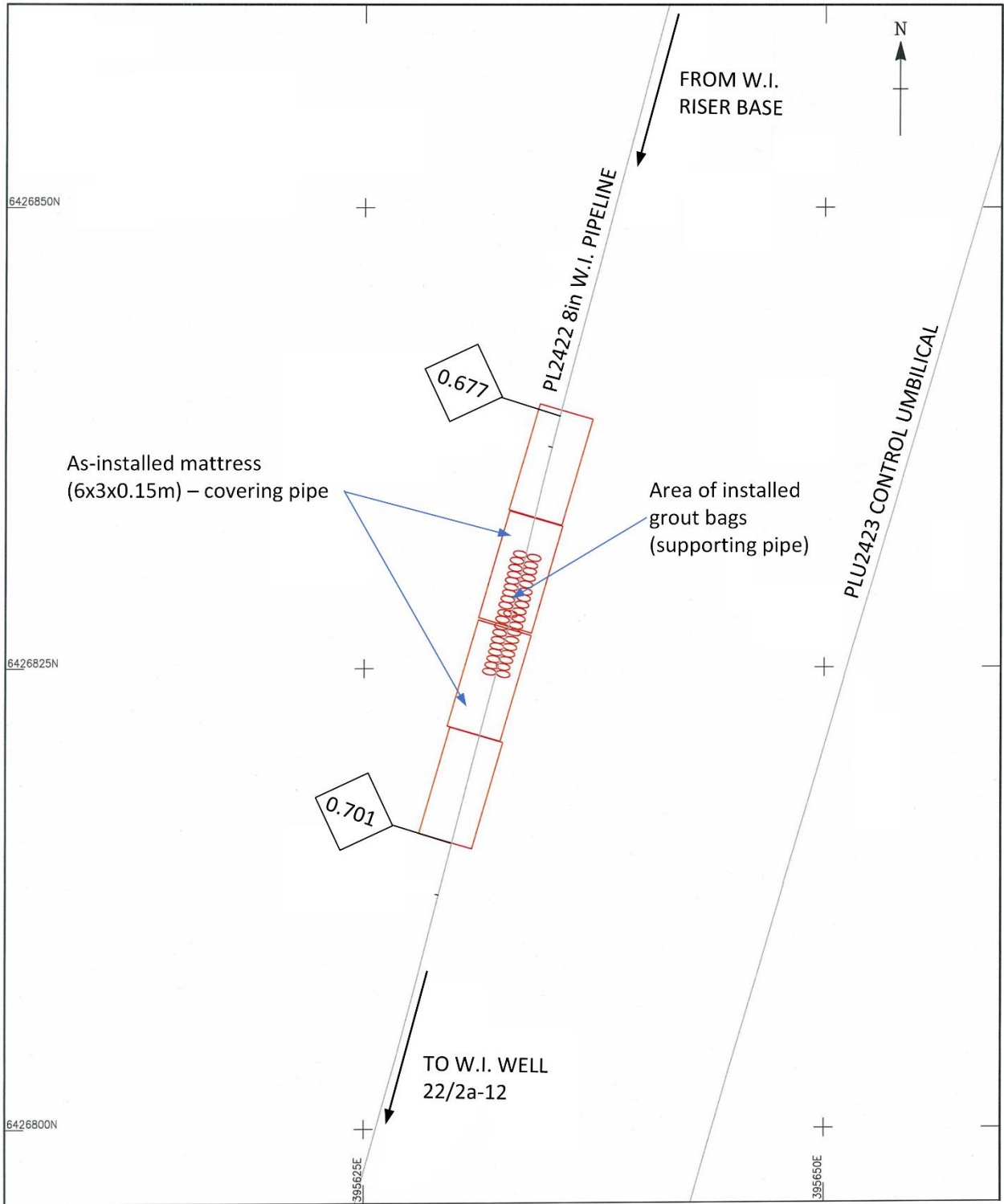

Figure 1.5.9: Freespan rectification work on PL2422 in 2010

Table 1.5.1: Adjacent Facilities

Operator	Name	Type	Direction / Distance from Hummingbird Spirit	Information	Status
Serica Energy UK Limited	PL815	24in pipeline	NW, ~3.4km	Condensate pipeline, Bruce to Forties Unity	Operational
bp Exploration Operating Company Limited	PL1079	8in pipeline	E, ~11.3km	Andrew to CATS Tee gas export pipeline	Operational
Ithaca Oil & Gas Limited	Sadie	WI Manifolds (3) & WI WHPS (3)	NWW, ~7.5km	Tied back to the Alba Northern Platform	Operational
Chrysaor UK Britannia Limited	Britannia	Platforms (2)	NW, ~9.8 & 9.9km	Export route for Brodgar, Callanish, & Enochdhu fields	Operational
bp Exploration Operating Company Limited	Andrew	Platform	NE, ~12.3km	Export route for Andrew, Arundel, Cyrus, Farragon and Kinnoull fields	Operational
	Andrew	Towhead & PLEM Towhead	NE, ~12.6km	Tied back to the Andrew Platform	Operational
Ithaca Oil & Gas Limited	Alba North	Platform	NWW, ~12.9km	Oil exported via pipeline PL927/PL928 to Alba FSU	Operational
Ithaca Oil & Gas Limited	Alba	FSU	NWW, ~14.4km	Oil exported via shuttle tanker	Operational
Chrysaor Production UK Limited	Enochdhu	Towhead	W, ~22.8km	Tied back to Callanish manifold and Britannia platforms	Operational
Chrysaor North Sea Limited	Maria	Manifolds (2) & Wellheads (2)	NEE, ~28.6km	Tied back to the CATS riser tower	Operational
Apache North Sea Limited	Bacchus West	Wellhead	S, ~26.2km	Tied-back to Bacchus Towhead	Operational
Apache North Sea Limited	Bacchus	Towhead	S, ~26.8km	Tied back to Forties Alpha	Operational
Apache North Sea Limited	Bacchus South	Wellhead	S, ~26.8km	Tied-back to Bacchus Towhead	Operational
Apache Beryl I Limited	Aviat	Wellhead	SSE, ~29.7km	Tied back to Forties infrastructure	Operational
Apache North Sea Limited	Forties Alpha	Platform	SSW, ~29.8km	Part of Forties field	Operational

Impacts of Decommissioning Proposals

There are no direct impacts on adjacent facilities from the decommissioning works associated with the Chestnut installations and pipeline infrastructure.

As part of the operational phase any potential in combination or cumulative impacts will be mitigated by a risk assessment and appropriate mitigations will be built into the project execution documentation. This approach will be accompanied via direct communication with the parties involved, and the submission of MATs and SATs.

1.6 Industrial Implications

The activities to disconnect or sever and recover the Chestnut installations, surface laid pipelines and associated structures, and protection and stabilisation features will be completed using one or

a combination of vessels including ROV Support Vessel (ROVSV), Construction Support Vessel (CSV), Multi Support Vessel (MSV) and Subsea Support Vessel (SSV).

It is the intention of the owners of the installations and pipelines to develop a contract strategy and Supply Chain Action Plan that will result in an efficient and cost-effective execution of the decommissioning works. Where appropriate existing framework agreements may be used for decommissioning of the pipelines and pipeline stabilisation features. Spirit Energy will seek to combine the decommissioning activities with other development or decommissioning activities to reduce mobilisation costs should the opportunity arise. The decommissioning schedule is extended to allow flexibility for when decommissioning operations are conducted and completed.

2. DESCRIPTION OF ITEMS TO BE DECOMMISSIONED

2.1 Subsea Installations & Stabilisation Features

Table 2.1.1: Subsea Installations and Associated Features					
Subsea Installations Including Stabilisation Features	No.	Mass (Te) / Size (m)	Location		Comments/ Status
			WGS84 Decimal	WGS84 Decimal Minute	
P1 WHPS	1	93 16 x 16 x 6.5	57.97662°N 1.23991°E	57°58.59718N 1°14.3945E	4x 'Anchortech' 3m x 1.5m steel piles, 15.5m long (Figure 2.1.2)
P1 WHPS Anode skid	1	0.5 1.8 x 2 x 0.5			No protection frame
P2/P4 WHPS	1	58 5.7x5.7x3.3	57.9519°N 1.21525°E	57°57.11418N 1°12.91512E	Not piled
P2/P4 WHPS Anode skid	1	0.5 1.8 x 2 x 0.5			No protection frame
P3 Well WHPS	1	58 5.7x5.7x3.3	57.95218°N 1.21393°E	57°57.13105N 1°12.83604E	Not piled
P3 WHPS Anode skid	1	0.5 1.8 x 2 x 0.5			No protection frame
WI Well WHPS	1	58 5.7x5.7x3.3	57.95662°N 1.22888°E	57°57.39742N 1°13.73262E	Not piled
WI WHPS Anode skid	1	0.5 1.8 x 2 x 0.5			No protection frame

NOTES:
1. No stabilisation features such as concrete mattresses, grout bags, or deposited rock are associated with the items listed above.

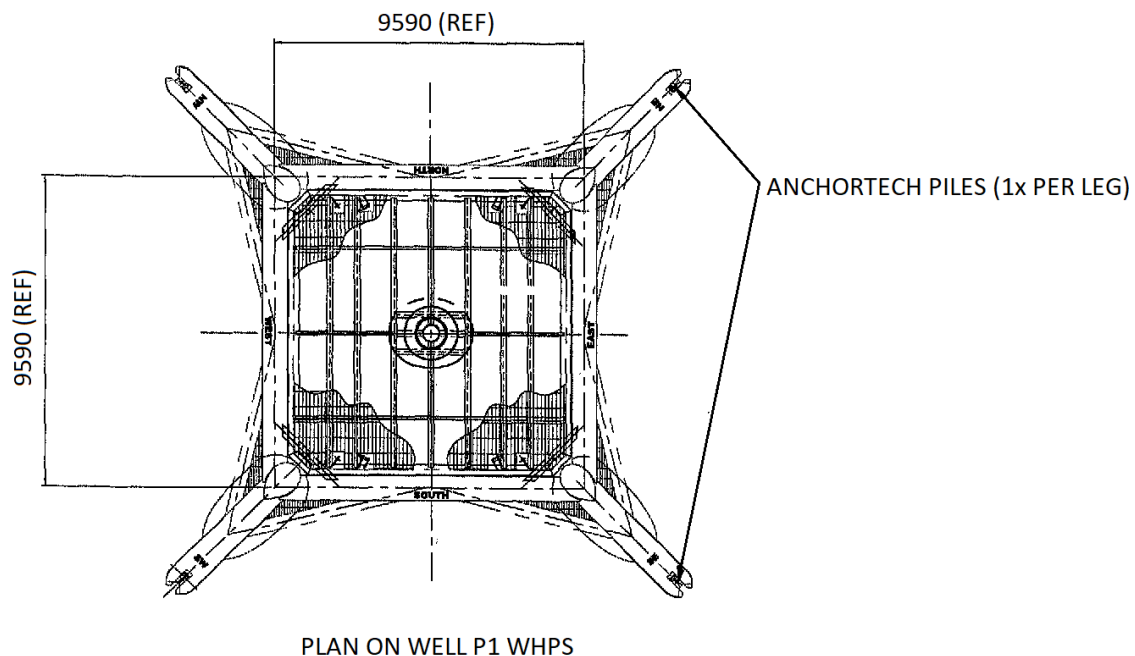

Figure 2.1.1: Well P1 WHPS

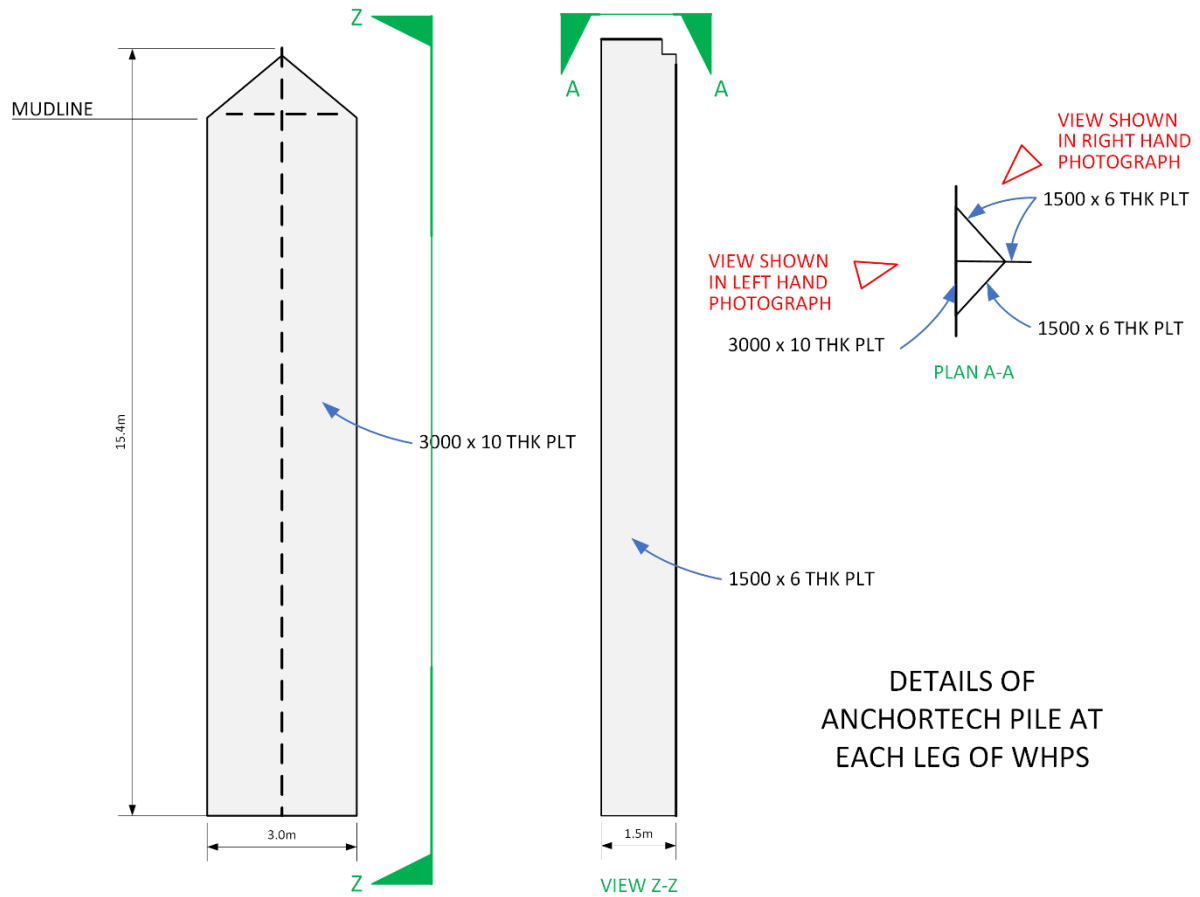

Figure 2.1.2: Well P1 WHPS 'Anchortech' piles (4x)



Figure 2.1.3: Well P1 WHPS 'Anchortech' piles²

² These photographs are referred to in Figure 2.1.2. As an indication of scale only, both show an Anchortech pile with the 'Machtech™ 120in diamond wire cutter: <https://mactechurope.co.uk/diamond-wire-saw-cutters-mactech-europe/>.

2.2 Pipelines including Stabilisation Features

Table 2.2.1: Pipeline/Flowline/Umbilical Information

Description	Pipeline Number (as per PWA)	Diameter (NB) (inches) ²	Length (m)	Description of Component Parts	Product Conveyed	From – To End Points ³	Burial Status	Pipeline Status	Current Content
Production pipeline system	PL2421 (5)	6	40	Pipespools, steel coated with 3LPP	Oil	Well P1 to Production RB	Surface laid	Out of use	Seawater
	PL2421 (6)	8	5			Mounted on production RB			
Water injection pipeline system	PL2422 (2)	8	5	Pipespools, steel coated with 3LPP	Produced water & de-aerated seawater	Mounted on WI RB	Surface laid	Out of use	Seawater
	PL2422 (3)	8	2,400	Flexible water injection flowline Composite		WI RB to tie-in spools at end of WI flowline	Trenched and buried with good depth of cover		
	PL2422 (4)	8	2	Pipespools, steel coated with 3LPP		End of flexible flowline to WI Well 22/2-12	Surface laid		
Umbilical	PLU2423/J1	100mm	85	Hydraulic, chemical, electrical control system umbilical	Nitrogen, hydraulic fluids	Controls RB to production well 22/2a-11	Surface laid	Out of use	Seawater, hydraulic fluids, electrical signals & power
	PLU2423/J2 (2)	33mm	82, 90	Electrical control system jumper	Electrical signals	Controls RB to production well 22/2a-11	Surface laid		n/a
	PLU2423/J3 (4)	122mm	2,385	Hydraulic, chemical, electrical control system umbilical	Chemicals, Methanol, Hydraulic fluids, Electrical signals	Controls RB to WI Well 22a/2-12	Trenched and buried with good depth of cover		Seawater, hydraulic fluids, electrical signals & power
Umbilical	PLU2544 (1)	153mm	10	Control & chemical umbilical jumper hoses	Chemicals, Methanol, Hydraulic fluids, Electrical signals & power	WI well 22/2a-12 to WI well SUT	Surface laid	Out of use	Seawater, hydraulic fluids
	PLU2544 (2)	153mm	980	Control & chemical umbilical		WI well SUT to P2 well SUT	Trenched and buried with good depth of cover		
	PLU2544 (3)	153mm	10	Control & chemical umbilical jumper hoses		Well P2 SUT to Well P2	Surface laid		
	PLU2544 (4)	153mm	10	Control & chemical umbilical jumper hoses		Well P2 to SDU	Surface laid		
	PLU2544 (5)	153mm	100	Control & chemical umbilical		SDU to Well P3	Surface laid		
Production pipeline system	PL2545 (1)	6	130	Pipespools, steel coated with 3LPP	Oil	Well P3 to Well P3 T-piece flange	Surface laid	Out of use	Seawater
	PL2545 (2)		97			Well P3 T-piece flange to Well P2 T-piece flange			

Table 2.2.1: Pipeline/Flowline/Umbilical Information

Description	Pipeline Number (as per PWA)	Diameter (NB) (inches) ²	Length (m)	Description of Component Parts	Product Conveyed	From – To End Points ³	Burial Status	Pipeline Status	Current Content
	PL2545 (3)		120	Pipespools, steel coated with 3LPP, piggybacked by PL2546(1)		Well P2 to Well P2 T-piece flange	Trenched and buried with good depth of cover		
	PL2545 (4)		3,400			Well P2 T-piece flange to Well P2 choke manifold			
Nitrogen injection system	PL2546 (1)	2	3,400	Pipespools, steel coated with 3LPP, piggybacked onto PL2545(4)	Nitrogen	Well P1 to Well P2 T-piece flange	Surface laid	Out of use	Seawater
	PL2546 (2)		44	Pipespools, steel coated with 3LPP		Well P2 to Well P2 T-piece flange			
	PL2546 (3)		95			Well P2 T-piece flange to Well P3 T-piece flange			
	PL2546 (4)		16			Well P3 T-piece flange to Well P3			
Electrical jumper	PL4706	28.7mm	150	E.P.R. / Polyurethane	Electrical power & signals	Prod Well P2 SDU to Well P3	Surface laid	Out of use	As product conveyed
Electrical jumper	PL4707	28.7mm	150	E.P.R. / Polyurethane	Electrical power & signals	Prod Well P2 SDU to Well P3	Surface laid	Out of use	As product conveyed

NOTES

- Under “Pipeline Number” the number in bracket is the pipeline ident on the PWA.
- If diameter is expressed in mm it refers to outside diameter of electrical cable or umbilical pipeline.
- For clarity, the description of the end-to-end points may differ slightly from those consented for simplification and to add clarity.
- Reference PWA application nos. 10-W-07 (PL2421, PL2422, PLU2423, PL2423/J1, PL2423/J2, PL2423/J3), 41-V-08 (PLU2544, PL2545, PL2546), 168-V-19 (PL4706 & PL4707), 373-V-18 (PL2422), & 224-V-17 (PLU2544, PL2545, PL2546). References to “well P2” should now read “well P4”.
- Decommissioning of the pipeline infrastructure during Phase 1 (e.g. PL2421(7), PL2422(1), PLU2423) is addressed in the Hummingbird Spirit Decommissioning Programmes [3];
- PLU2544 2x signal & 2x power cores (Nos 1,2,3 and 4) disconnected at both SDU and at P3 ends and left *in situ* under mattress protection.
- PL4706 replaces the functionality of cores 1 and 3 in PLU2544 between P2 SDU and Production Well P3.
- PL4707 replaces the functionality of cores 2 and 4 in PLU2544 between P2 SDU and Production Well P3.
- Production well P2 22/2a-16Y was sidetracked and is now designated P4 22/2a-17.

Table 2.2.2: Subsea Pipeline Structures & Stabilisation Features

Stabilisation Feature & Size (m)	Total Number	Total Mass (Te)	Location(s)		Exposed/Buried/Condition
			WGS84 Decimal (If quoted):	WGS84 Decimal Minute (If quoted)	
Concrete mattresses ¹	87	400.2	PL2422: 34x south of WI RB PLU2423/J3: 25x south of controls RB PLU2423/J1, PLU2423/J2: 14x between controls RB and well P1 PL2421: 4x between production RB and well P1 PL2545, PL2546: 9x on south approach to well P1, 3x buried under deposited rock PL2421(5): 1x between choke valve skid and well P1 Refer Figure 1.5.7.		Exposed except for 3x buried under deposited rock.
	40	184	PLU2544: 7x on north approach to well P2/P4 PL2545, PL2546: 10x on south approach to well P2/P4 PLU2544, PL2545, PL2546: 23x on approach to well P3 Refer Figure 1.5.6		
	42	193.2	PL2422: 22x on north approach to WI well PLU2423/J3: 14x on north approach to WI well PLU2544: 6x on south approach from WI well Refer Figure 1.5.8		
	4	18.4	PL2422: 4x between KP0.677 and KP0.689 Refer Figure 1.5.9		Inside the trench the mattresses are buried except for a short section that covers a buckled section of the flowline and where the mattresses overlap the sides of the trench where they are partly exposed. Their burial status will be confirmed at the time of decommissioning.
Grout bags (1Te) ²	11	11	PL2544: 11x ramp for pipeline at WI well. Refer Figure 1.5.8		Exposed but to be confirmed at time of decommissioning.
	30	30	PL2422: 30x between KP0.677 and KP0.689 Refer Figure 1.5.9		These are buried, but their burial status will be confirmed at the time of decommissioning.
Grout bags (25kg) ²	2,204	55.8	PL2422: 63x south of WI RB PLU2423/J3: 1,259x south of controls RB PLU2423/J1, PLU2423/J2: 727x between controls RB and well P1		Exposed in mattress joints or buried under the mattresses protecting the umbilical(s). To be confirmed at time of

Table 2.2.2: Subsea Pipeline Structures & Stabilisation Features

Stabilisation Feature & Size (m)	Total Number	Total Mass (Te)	Location(s)		Exposed/Buried/Condition
			WGS84 Decimal (If quoted):	WGS84 Decimal Minute (If quoted)	
			PL2421: 51x between production RB and Well P1 PL2545, PL2546: 53x on south approach to well P1 PL2545, PL2546: 51x between choke valve skid and well P1 Refer Figure 1.5.7		decommissioning.
	1,603	40.6	PLU2544: 388x on north approach to Well P4 PL2545, PL2546: 53x on south approach to well P2/P4 PLU2544, PL2545, PL2546: 1,162x on approach to well P3 Refer Figure 1.5.6		
	1,175	29.7	PL2422: 109x on north approach to WI well PLU2423: 727x on north approach to WI well PLU2544: 339x on south approach from WI well Refer Figure 1.5.8		
Deposited rock ³	575m	4,635	Intermittent throughout the length of the PL2422, used to mitigate against UHB and any shallow depth of cover at time of installation. For more details refer comparative assessment [4]		Expected to be predominantly exposed.

NOTES:

1. All concrete mattresses are 6m x 3m x 0.15m (mass ~4.6Te each).
2. Quantity of grout bags is an estimate as the as-built details are not definitive.
3. The quantity of deposited rock is based on 'as-built' installation reports.

2.3 Pipeline Structures

Table 2.3.1: Subsea Pipeline Structures and Associated Features					
Stabilisation Feature & Size (m)	Total Number	Total Mass (Te)	Location(s)		Exposed/Buried/Condition
			WGS84 Decimal (If quoted):	WGS84 Decimal Minute (If quoted)	
Production riser base (4.9 x 4.93 x 1.8m)	1	31.5	57.97672°N, 1.24025°E Refer Figure 1.5.4	57°58.60318N, 1°14.41495E Refer Figure 1.5.4	Exposed.
Water injection riser base (4.9 x 4.93 x 1.8m)	1	31.5	57.97661°N, 1.23842°E Refer Figure 1.5.4	57°58.59657N, 1°14.30514E Refer Figure 1.5.4	Exposed.
Control umbilical riser base (6.5 x 6 x 5.35m)	1	48.9	57.97709°N, 1.23924°E Refer Figure 1.5.4	57°58.62568N, 1°14.35413E Refer Figure 1.5.4	Exposed.
Choke manifold & protection structure (3 x 3.5 x 3.6m)	1	16.7	57.9765°N, 1.24009°E Refer Figure 1.5.7	57°58.59013N, 1°14.4051E Refer Figure 1.5.7	Exposed.

2.4 Wells

Table 2.4.1: Well Information			
Well ID	Designation	Status	Category of Well
22/2a-11X	Oil production	In Service	SS-3-4-3
22/2a-12	Water Injection	Decommissioned, AB1	SS-3-4-3
22/2a-16Y	Oil production	Decommissioned, AB1	SS-3-4-3
22/2a-19Z	Oil production (sidetracked from 22/2a-16)	In Service	SS-3-4-3
22/2a-17	Water Injection (sidetracked from 22/2a-12)	In Service	SS-3-4-3
22/2a-18	Oil production	In Service	SS-3-4-3

For details of well categorisation please refer to the latest version of the Oil & Gas UK Guidelines³ for the Decommissioning of Wells.

2.5 Drill Cuttings

Table 2.5.1: Chestnut Drill Cutting(s) Pile Information		
Location of Pile Centre	Seabed Area (m ²)	Estimated Volume of drill Cuttings (m ³)
The results of the Environmental Baseline Survey [1] indicate that there are no drill cuttings present.	n/a	n/a

2.6 Inventory Estimate

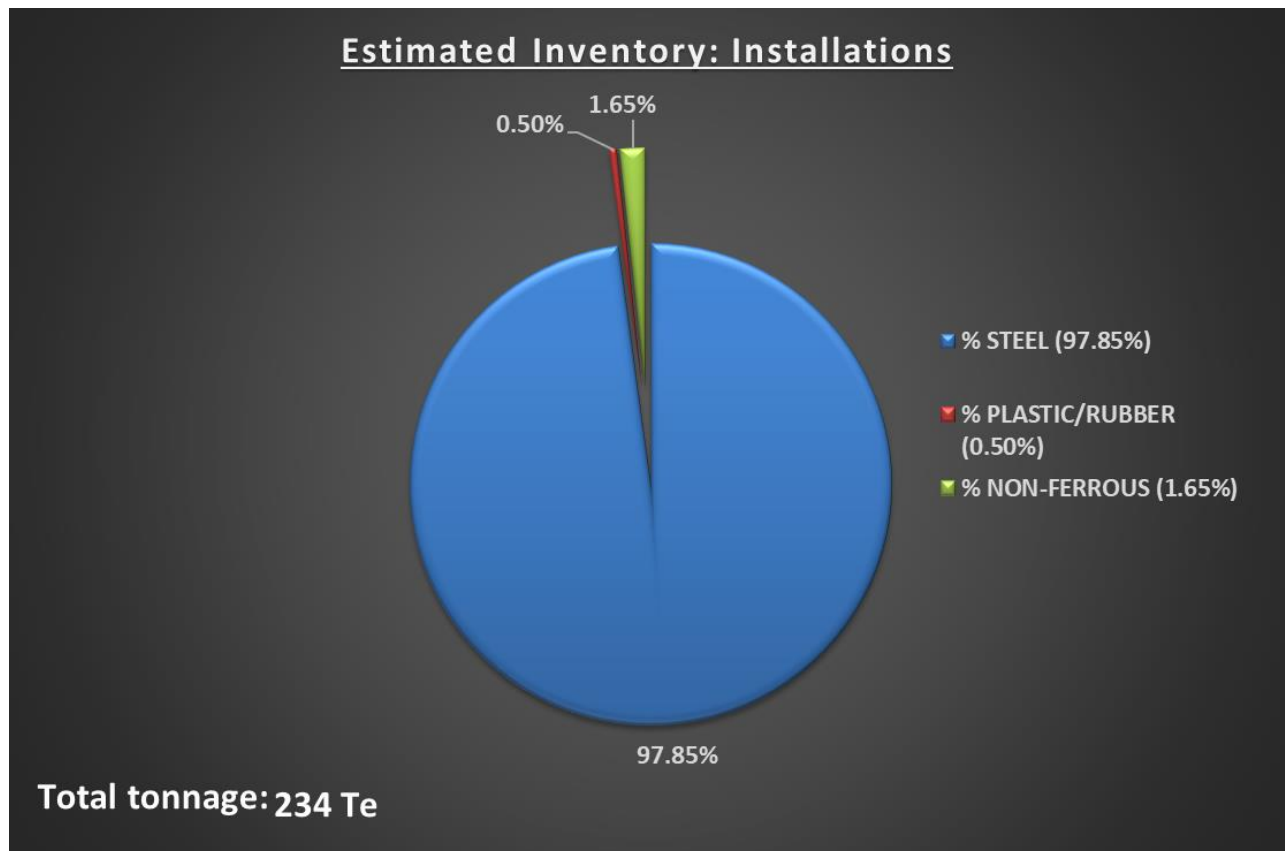

Figure 2.6.1: Pie-Chart of estimated inventories (installations)

³ "Oil & Gas UK" has now been rebranded "Offshore Energy UK"

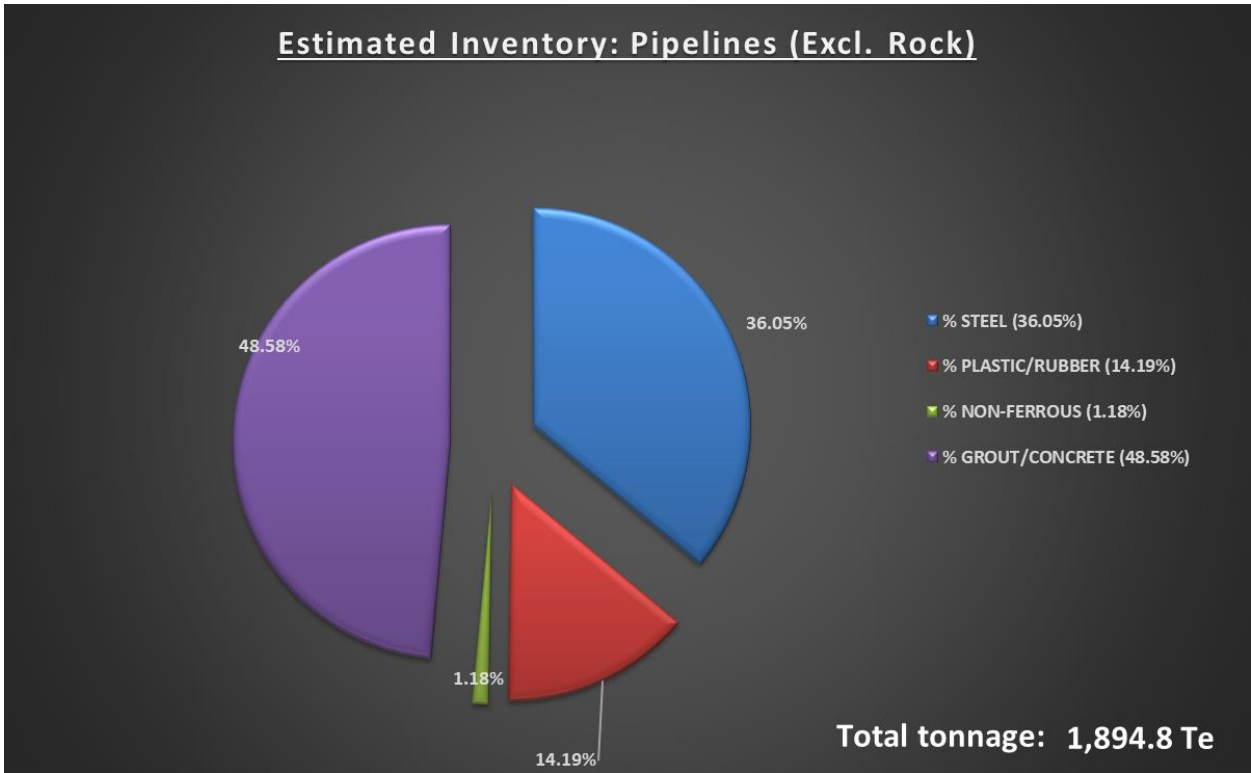

Figure 2.6.2: Pie-Chart of estimated inventories (pipelines)⁴

⁴ Includes riser bases, choke manifold & protection structure as well as protection and stabilisation features but excludes deposited rock.

3. REMOVAL AND DISPOSAL METHODS

Waste will be dealt with in accordance with the Waste Framework Directive. The re-use of an installation, pipeline, or umbilical pipeline or parts thereof, is first in the order of preferred decommissioning options and such options are currently under investigation. Waste generated during decommissioning will be segregated by type and periodically transported to shore in an auditable manner through licensed waste contractors. Steel and other recyclable metals are estimated to account for the greatest proportion of the materials inventory. Materials for which no re-use or recycling opportunities are available will be tracked through to final disposal.

Geographic locations of potential disposal yard options may require the consideration of Trans Frontier Shipment of Waste (TFSW), including hazardous materials. Early engagement with the relevant waste regulatory authorities will ensure that any issues with TFSW are addressed.

3.1 Subsea Installations and Associated Features

Table 3.1.1: Subsea Installations and Associated Features			
Subsea installations and stabilisation features	Number	Option	Disposal Route (if applicable)
P1 WHPS	1	Complete removal. Please refer section 3.1.1 below.	Return to shore for reuse or recycling.
P1 WHPS Anode skid	1	Complete removal.	
P2/P4 WHPS	1	Complete removal.	
P2/P4 WHPS Anode skid	1		
P3 Well WHPS	1		
P3 WHPS Anode skid	1		
WI Well WHPS	1		
WI WHPS Anode skid	1		

3.1.1 Well P1 WHPS

WHPS description: The WHPS for well P1 is a ‘standard’ WHPS but it is piled. The piles are an unusual design in that they are fabricated from 3.0m x 10mm and 1.5m x 6mm plate welded together and 15.4m long (Figure 2.1.2 above) and so the seabed will need to be excavated access the required cut depth (refer Figure 3.1.1 and Figure 3.1.2 below). To compromise excavation requirements and to minimise impact on the seabed, given that the seabed is stable in the area it is proposed that they are cut at 1.0m instead of 3m below seabed as the excavation into the seabed will need to be much deeper to gain sufficient access for the cutting tools. This will be accounted for in the Environmental Appraisal [2].

Assuming there would be no technical issues the piles will be cut at 1.0m below the seabed. Should any difficulties be encountered in accessing the piles, OPRED will be consulted before the piles are cut.

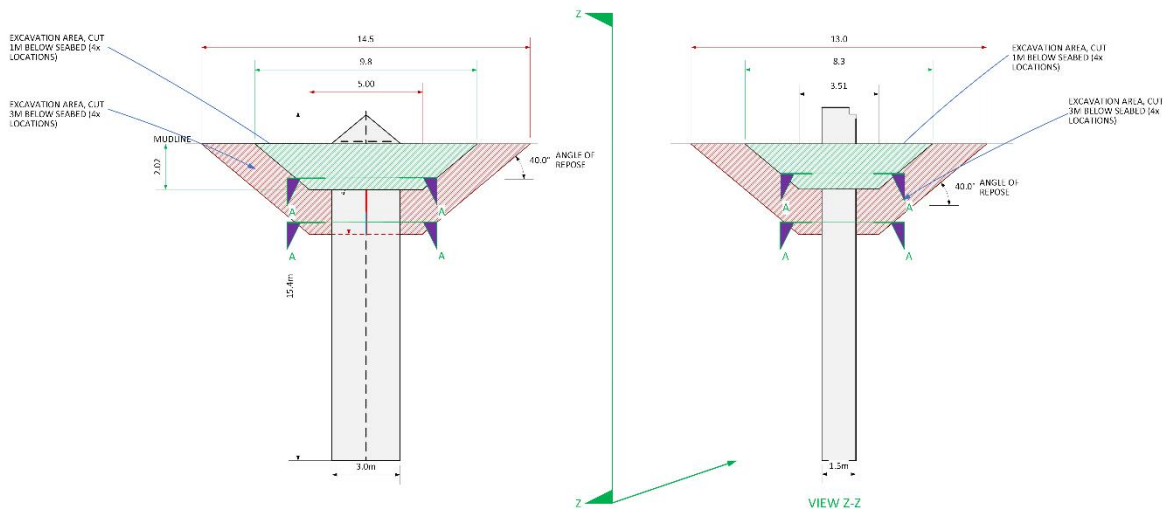

Figure 3.1.1: WHPS P1 indicative pile excavation requirements, sections (approx.)

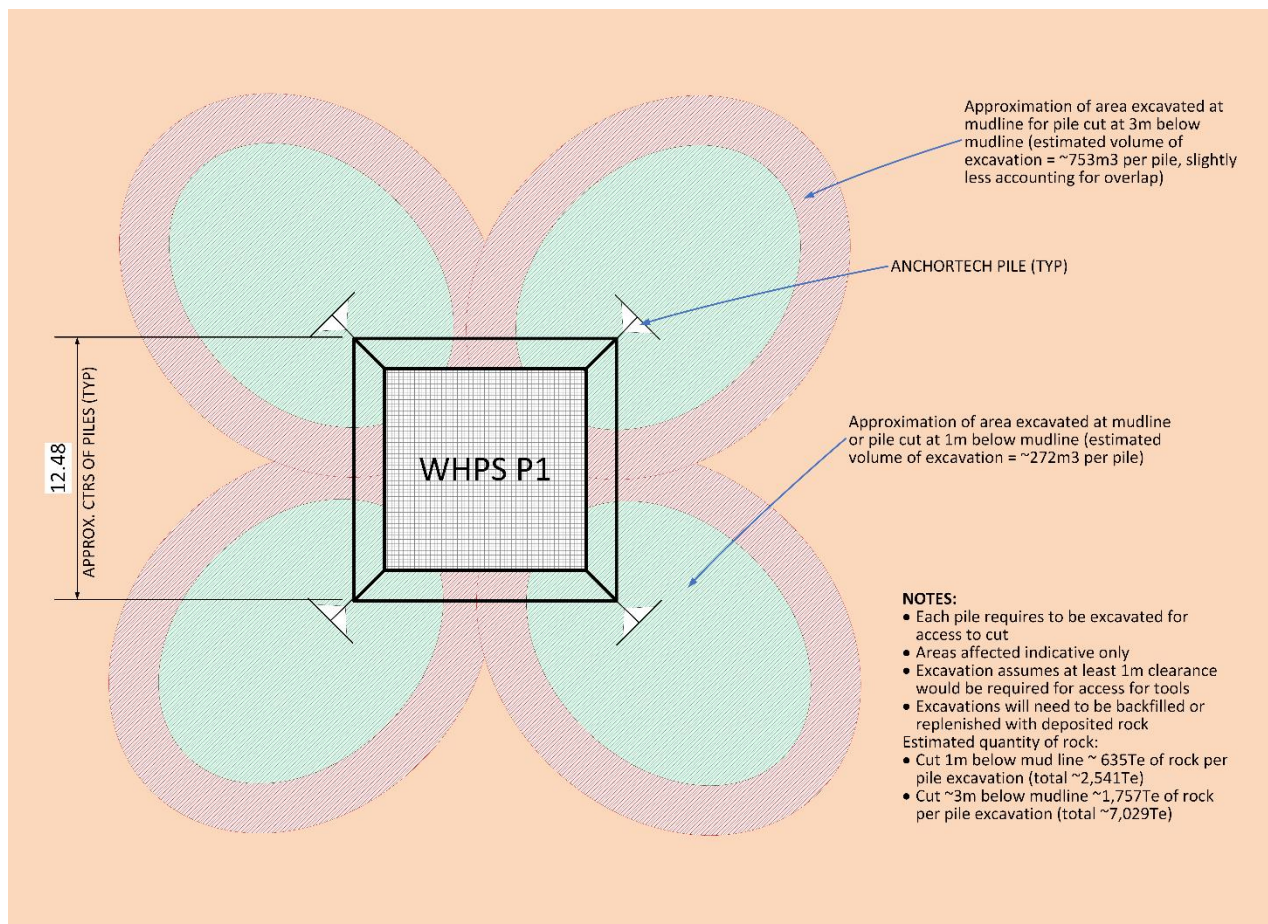

Figure 3.1.2: WHPS P1 indicative pile excavation requirements, plan view

3.2 Pipelines

3.2.1 Decommissioning options for pipelines

There is an implicit assumption that options for re-use of the pipelines have been exhausted prior to the facilities and infrastructure moving into the decommissioning phase and associated comparative assessment. Therefore, the re-use option has been excluded from the assessment.

As the pipelines are all buried and stable two decommissioning options were considered:

- **Complete removal** – This would involve the complete removal of the pipelines by whatever means would be most practicable and acceptable from a technical perspective;
- **Leave *in situ*** – This would involve leaving the pipeline(s) *in situ* with no remedial works but possibly verifying their status via future surveys.

All surface laid equipment including pipelines that have not been trenched or buried will be completely recovered from the seabed up to the point where they are buried at trench depth and taken to shore for re-use or recycling or final disposal.

The decommissioning options summarised herein are supported by a comparative assessment where each decommissioning option was comparatively assessed against technical feasibility and efficacy, safety concerns, environmental and societal impacts, and cost [4]. For the purposes of the assessment the pipelines were considered as one of two pipeline groups as summarised in Table 3.2.1.

3.2.2 Decommissioning options for remediated PL2422 freespan

For the materials used to remediate a freespan between ~KP0.677 and ~KP0.701 in PL2422 the decommissioning options are described as follows:

- **Complete removal** – this would involve the complete removal of the grout bags and concrete mattresses, removing the short section of PL2422 (~12m long) and replacing the excavated material with deposited rock.
- **Partial removal** – this would involve removal of the overlying concrete mattresses and replacing them with deposited rock.
- **Leave *in situ*** – this would involve leaving the grout bags and overlying mattresses *in situ* with no remedial works.

In all instances legacy surveys will be required.

Table 3.2.1: Pipeline decommissioning summary

Pipeline ID	Comment / Burial status	Length (km)	Complete removal	Leave <i>in situ</i>	Group
PL2421(5,6)	Pipespools, surface laid	~0.045	X		n/a
PL2422(3)	Flexible flowline, trenched and buried	~2.400		X	1
PLU2423(J1)	Jumper, surface laid, covered with mattresses	~0.085	X		n/a
PLU2423(J2)	Jumper, surface laid, covered with mattresses	~0.082	X		n/a
PLU2423(J3)	Umbilical, trenched and buried	~2.385		X	1
PLU2544(2)	Umbilical, trenched and buried	~0.980		X	1
PLU2544(4)	Jumper, surface laid, covered with mattresses	~0.100	X		n/a
PL2545(1)	Pipespools, surface laid	~0.130	X		n/a
PL2545(2)	Pipespools, surface laid	~0.097	X		n/a
PL2545(3)	Pipespools, surface laid	~0.120	X		n/a
PL2545(4)	Piggybacked; trenched and buried, incl. rock	~3.400		X	2
PL2546(1)	Piggybacked; trenched and buried, incl. rock	~3.400		X	2
PL2546(2)	Pipespools, surface laid	~0.095	X		n/a
PL2546(3)	Pipespools, surface laid	~0.016	X		n/a
PL4706	Electrical jumper, surface laid	~0.150	X		
PL4707	Electrical jumper, surface laid	~0.150	X		

NOTES:

1. Diameters quoted for pipelines are nominal bore, while diameters quoted for umbilicals are outside diameter.
2. Pipeline spools or jumpers ≤10m long are not listed here on the basis that they would be fully removed.
3. Surface laid pipelines <100m listed in this table have not been subjected to a comparative assessment on the basis that they would be fully removed.
4. Surface laid sections of pipelines and umbilicals on the final approaches would be fully removed to trench depth.

It is worth noting here that ordinarily a pipeline span such as that in PL2422 at KP0.677 would be

considered a candidate for partial removal. However, as subsequent survey data have indicated that the flowline remains buried, it is recommended that the associated grout bags and concrete mattresses remain *in situ* but be subject to overtrawl. This would confirm the extent to which potential snagging hazards remain following completion of decommissioning activities. As the flowline is not situated in an environmentally sensitive area this would be acceptable.

Decommissioning of the pipeline infrastructure during Phase 1 (e.g., PL2421(7), PL2422(1), PLU2423) is addressed in separate Decommissioning Programmes [3].

3.2.3 Outcome of comparative assessment

Table 3.2.2: Pipeline Decommissioning Proposals		
Pipeline or Group	Recommended option	Justification
PL2422(3) PLU2423(J3) PLU2544(2) PL2545(4) PL2546(1)	<p>Leave the buried sections of the pipelines <i>in situ</i>, remove surface laid sections down to trench depth which is typically at the point where the protection and stabilisation features start, or at the start or end of any deposited rock.</p> <p>Reinstate excavated material to protect the cut pipeline ends, but should any difficulties be encountered, as a contingency, small quantities of deposited rock may be deposited over the remaining cut pipeline ends. This is accounted for in the Environmental Appraisal [2].</p>	Leaves a clear seabed free of potential snagging hazards.

3.2.4 Pipeline protection and stabilisation features (PL2422)

It is intended that all exposed concrete mattresses and grout bags are recovered, except for those used to remediate a freespan in PL2422. These were subject to a comparative assessment.

Outcome of comparative assessment for PL2422 grout bags and concrete mattresses

The burial status of the concrete mattresses will be confirmed, although the indications are that they will be partly exposed. If they are buried, the recommendation is that they be left *in situ*. If they are found to be partially exposed and are considered to present a snagging hazard, the partial removal option should be implemented. This option involves recovering the overlying concrete mattresses to shore and replacing them with deposited rock, ensuring that the section of PL2422 affected (~12m long underneath the concrete mattresses) will remain buried. Future surveys will be required to confirm burial status.

Table 3.2.3: Pipeline Protection and Stabilisation Features			
Asset	No	Description	Disposal Route (if applicable)
Concrete mattresses	87	Refer Table 2.2.2 & Figure 1.5.7	It is intended to recover all exposed concrete mattresses to shore for re-use, recycling, or disposal. However, in the event of practical difficulties OPRED will be consulted.
	40	Refer Table 2.2.2 & Figure 1.5.6	
	42	Refer Table 2.2.2 & Figure 1.5.8	
	4	Refer Table 2.2.2 & Figure 1.5.9	It the concrete mattresses are found to pose a snagging hazard at the time of decommissioning, they will be recovered to shore for re-use and recycling or disposal and replaced with deposited rock (~121Te).
Grout bags (1Te)	11	Refer Table 2.2.2 & Figure 1.5.8	It is intended that all 1Te grout bags to shore for re-use, recycling, or disposal. However, in the event of practical difficulties OPRED will be consulted.

Table 3.2.3: Pipeline Protection and Stabilisation Features

Asset	No	Description	Disposal Route (if applicable)
	30	Refer Table 2.2.2 & Figure 1.5.9	Leave <i>in situ</i> .
Grout bags (25kg)	2,204	Refer Table 2.2.2 & Figure 1.5.7	It is intended to recover all exposed 25kg grout bags to shore for re-use, recycling, or disposal.
	1,603	Refer Table 2.2.2 & Figure 1.5.6	
	1,175	Refer Table 2.2.2 & Figure 1.5.8	
Deposited rock	4,635Te	Refer Table 2.2.2	Leave <i>in situ</i> .

3.2.5 Pipeline structures

Table 3.2.4: Pipeline Structures

Asset	No	Description	Disposal Route (if applicable)
Production riser base	1	Refer Table 2.2.2 & Figure 1.5.4	Recover structure to shore for re-use, recycling, or disposal.
Water injection riser base	1	Refer Table 2.2.2 & Figure 1.5.4	
Control umbilical riser base	1	Refer Table 2.2.2 & Figure 1.5.4	
Choke manifold & protection structure	1	Refer Table 2.2.2 & Figure 1.5.7	

3.3 Wells

Table 3.3.1: Well Decommissioning

The Chestnut field hosts a total of three production wells and one water injection well. (**Chestnut:** 22/2a-11X, 22/2a-19Z, 22/2a-12, 22/2a-17 and 22/2a-18). All wells will be decommissioned in accordance with the latest version of the Oil & Gas UK⁵ Well Decommissioning Guidelines. A Master Application Template and the supporting Supplementary Application Template will be submitted in support of works conducted. An application to decommission the wells will be made via the online Well Operations Notification System (WONS) on the NSTA Energy Portal. Well decommissioning will be scheduled in accordance with the outline schedule presented in section 6.3.

3.4 Waste Stream Management Methods

Table 3.4.1: Waste Stream Management Methods

Waste Stream	Removal and Disposal method
Bulk liquids	As part of Phase 1 of the decommissioning operations bulk hydrocarbons have already been exported, with any residual hydrocarbons removed from the FPSO in accordance with contractual agreements with the vessel owner. Any associated bulk seawater from the vessel will have been cleaned and disposed overboard or downhole under permit. The production risers and pipelines, water injection flowlines and umbilical pipelines will have been left filled with seawater as appropriate prior to being disconnected. Further cleaning and decontamination will take place onshore prior to recycling / re-use or disposal.
Marine growth	For subsea equipment, marine growth is likely to dry out and detach itself while it is in transit. Marine growth that remains attached to the subsea equipment after load-in to the onshore dismantling site will be removed. It will be disposed of in accordance with the regulations in force at the site following the licensed site operator's procedures, guidelines, and company policies.
NORM	Based on production records to date, NORM is expected. Tests for NORM will be undertaken offshore, and any NORM encountered will be dealt with and disposed of in accordance with guidelines and company policies.
Asbestos	No asbestos is associated with the installations, pipelines or pipeline structures. However, any such material found will be dealt with and disposed of in accordance with guidelines and company policies.

⁵ "Oil & Gas UK" has now been rebranded "Offshore Energy UK"

Table 3.4.1: Waste Stream Management Methods	
Waste Stream	Removal and Disposal method
Other hazardous wastes	Will be recovered to shore and disposed of according to guidelines and company policies and will also take place under appropriate permits.
Onshore Dismantling sites	Appropriately licensed sites will be selected. Dismantling site must demonstrate proven disposal history and waste stream management throughout the deconstruction process and demonstrate their ability to deliver reuse and recycling options.

Table 3.4.2: Inventory Disposition			
Inventory	Total inventory (Te)	Planned tonnage to shore (Te)	Planned left <i>in situ</i> (Te)
Installations	234	234	0
Pipelines, structures & stabilisation	1,826	1,059	767
Deposited rock	4,635	0	4,635

Table 3.4.3: Re-use, Recycle & Disposal Aspirations for Recovered Material			
Inventory	Re-use	Recycle	Disposal (e.g., Landfill)
Installations	>95%	<5%	<5%
Pipelines, structures & stabilisation	<5%	>90%	<10%

All recovered material will be transported to shore for reuse, recycling, or disposal. The expectation is that any synthetic materials associated with the pipelines will be incinerated with the resultant heat being used for energy. Any materials that cannot be recycled in this way would likely be destined for landfill. It is not possible to predict the market for reusable materials with any confidence so the figures in Table 3.4.3 are aspirational.

4. ENVIRONMENTAL APPRAISAL

4.1 Environmental Sensitivities

The environmental characteristics and sensitivities are such that the seabed area is stable with relatively homogenous community. It is typical of sandy sediments, generally diverse and evenly distributed community with low taxonomic dominance.

The background hydrocarbon and metal concentrations are generally uniform and typical of the northern North Sea, concentrations of hydrocarbons and metals were below recognised toxicity thresholds. They were not found to have exerted any notable influence on the macrofaunal community structure.

The seabed sediments consist of very silty, fine sand down to approximately 0.8m. Underlying the seabed sand veneer, very soft silty clay extends to depths of between 20-30m below seabed throughout the Chestnut area. There is no evidence of significant lateral variations in soil properties within the upper 20m below the seabed, except in the vicinity of pockmarks where fine material has been expunged in the process of escaping gas. Authentic cement sediments associated with the seepage of gas may be present within and around the pockmark features.

Although pockmarks are a feature of the Chestnut area, Methane-Derived Authigenic Carbonate matter has not been found in any of the pockmarks examined. Further, the indications are that the nearest pockmarks would be ~100m from any decommissioning activities and therefore unlikely to be affected.

The pipelines are in UKCS block 22/2a in the Central North Sea in a water depth ~123m relative to LAT. The pipelines are not located in a protected area or area of conservation. The nearest MPA is the Norwegian Boundary Sediment Plan ~30km to the north-east, and the nearest SAC is the Scanner Pockmark SAC 45km to the north-west (Figure 1.5.2).

4.2 Potential Environmental Impacts and their Management

4.2.1 Overview

The significance of any environmental impacts and risks (potential impacts) associated with each element of the project activities are described in Table 4.2.1.

4.2.2 Key control and mitigation measures

Table 4.2.1: Key Control and Mitigation Measures	
Underwater Noise	<ul style="list-style-type: none"> • A SIMOPS plan for vessel activity in the field will be put in place • Vessel, cutting and trenching operations will use standard methods and equipment. No explosives used.
Discharges to Sea	<ul style="list-style-type: none"> • All contracted vessels will operate in line with IMO and MARPOL regulations • Pipelines and spool are to be flushed, filled with seawater, and isolated prior to disconnection • All discharges will be permitted under applicable UK legislation.
Accidental Events	<ul style="list-style-type: none"> • All contracted vessels will have a ship-board oil pollution emergency plan (SOPEP) in place. • A Collision Risk Management Plan will be developed and implemented. • Agreed arrangements in place with oil spill response organisation for mobilising resources in event of a spill. • Existing field OPEP in place to reduce the likelihood of hydrocarbon release and define spill response in place. • Lifting operations will be planned to manage the risk. • Recovery of any dropped objects will take place. • Vessel contactors will have procedures for fuel bunkering that meet Spirit Energy's standards. • Where practicable, re-fuelling will take place during daylight hours only.
Physical Presence of Infrastructure & Vessels	<ul style="list-style-type: none"> • All vessels will comply with standard marking conditions and consent to locate conditions. • If required, a specific SIMOPS plan for vessel activity in the field will be put in place, noting that a standard DSV SIMOPS Guideline already exists for the asset. • All seabed infrastructure will be fully protected on the seabed in the interim period between Phase 1 & 2. • Should full seabed clearance of the FPSO 500m zone not be completed, means of protection will be provided by Spirit Energy. This is explained in the Decommissioning Programmes for Phase 1 [3]; • Small quantities of rock may be required where exposed pipeline ends remain after severance at existing deposited rock. • Seabed clearance certificate issued if an overtrawl survey is carried out, otherwise survey findings will be described in the close out report.
Atmospheric Emissions & Energy Use	<ul style="list-style-type: none"> • Time vessels spend in the field will be optimised, with a SIMOPS plan in place. • Reuse or recycling of materials will be the preferential option.
Waste	<ul style="list-style-type: none"> • Onshore treatment will take place at waste management site with appropriate permits and licenses. • UK waste disposal sites will be used where practicable.
Seabed Disturbance	<ul style="list-style-type: none"> • Activities which may lead to seabed disturbance planned, managed, and implemented in such a way that disturbance is minimised. A Marine License will be in place for any planned operational disturbance. • Mechanical backfill of the excavated areas, but should any difficulties be encountered, as a contingency small quantities of deposited rock may be deposited over the remaining cut pipeline ends but no remedial seabed levelling of pipeline corridors. • Deposited rock will be used to remediate the excavations for the WHPS P1 piles. • Deposited rock will be used to remediate any excavations or removal of concrete mattresses associated with PL2422 between KP0.677 and KP0.701. • Debris survey undertaken on completion of the activities and where possible resultant debris will be recovered. • Minimising disturbance to seabed from overtrawl through liaison with fishing organisations and regulator.

Following the environmental assessment and implementation of additional control and mitigation measures where necessary, the level of environmental risk from the planned and unplanned decommissioning operations, is **low**. In addition, any cumulative impacts limited to seabed disturbance have been assessed and considered to be **low**. Therefore, the decommissioning of the Chestnut installations, pipelines and associated stabilisation features can be completed without causing significant impact to the environment.

5. INTERESTED PARTY CONSULTATIONS

5.1 Consultation Summary

During the public consultation period (28 October 2022 to 29 November 2022), copies of the Decommissioning Programmes were forwarded to the following Statutory Consultees:

- Global Marine Group (GMG);
- The National Federation of Fishermen’s Organisations (NFFO);
- The Northern Ireland Fish Producer’s Organisation (NIFPO); and,
- The Scottish Fishermen’s Federation (SFF).

Copies of the Decommissioning Programmes and supporting documents were made available as a download from the Spirit Energy website: www.spirit-energy.com/our-operations/decommissioning/.

Due to Covid-19 restrictions a bound copy was not sent to the local public library but via the Public Notice, advising that a digital or hardcopy of the Decommissioning Programmes can be made available on request.

A public notice was published in the following local newspapers by:

- “Press & Journal” on 28 October 2022
- “The (Edinburgh) Gazette” on 28 October 2022.

Please refer to Appendix B.1 for a copy of the public notices. The public notice gave instructions for representations to be made in writing by 29 November 2022. Spirit Energy received no comments nor any written or verbal representation from the public in direct response to the public notice or during the public consultation period.

Copies were also submitted for consideration to OPRED.

Table 5.1.1: Summary of Stakeholder Comments

Who	Comment	Response
INFORMAL CONSULTATIONS		
SFF	<p>A meeting was held with SFF on 26 May to discuss proposals for Phase 1. Proposals for Phase 2 were also discussed.</p> <p>Spirit mentioned PL2422. Remediated section of pipe ~700m south-south-west of Hummingbird Spirit would not have been fished due to its being inside the mooring area. The proposal to carry out overtrawl was discussed to confirm whether the 30x 1Te grout bags and 4x concrete mattresses would pose a snagging hazard should they be left <i>in situ</i> following decommissioning.</p> <p>A further meeting with held with SFF on 11 August 2022 to provide an update on the progress of Phase 1 of the decommissioning works as well as to discuss further the proposals for the materials used for rectifying the span in PL2422.</p>	<ul style="list-style-type: none"> • SFF had no adverse comment to make. • SFF were comfortable with the proposal in principle, but any decision should be supported by visual evidence (e.g. ROV footage). Should any remedial work be required, the preference would be for the 4x mattresses to be removed and replace with deposited rock sufficient to bury the pipeline. A statement to this effect will be included in the DP for Phase 2. • Use of a chain-mat could be optional, and the more usual trawl gear could be used if no snagging hazards appear to be present. • SFF has no adverse comment to make at the meeting on 11 August 2022.
STATUTORY CONSULTATIONS		
NFFO	The Decommissioning Programmes and supporting documentation were sent to NFFO via email on 28 October 2022.	No adverse comments were received with the NFFO being happy to defer to SFF as the decommissioning activities would be carried out in Scottish waters.
SFF	The Decommissioning Programmes and supporting documentation were sent to SFF	SFF had no adverse comments to make concerning the decommissioning proposals.

Table 5.1.1: Summary of Stakeholder Comments

Who	Comment	Response
	via email on 28 October 2022.	<p>noting that the piles for P1 WHPS will be cut at -1m below seabed.</p> <p>However, SFF have expressed the following reservations:</p> <p>For PL2422 if any of the concrete mattresses are found to be uncovered, their recommendation would be for the locality be buried under deposited rock.</p> <p>SFF also take the opportunity to express reservations concerning user of survey data to verify that an area is safe for fishing activity to be resumed. In their view the undertaking of trawl sweeps that would replicate the type of fishing activity that will resume in the area would be the safest approach.</p>
NIFPO	The Decommissioning Programmes and supporting documentation were sent to NIFPO via email on 28 October 2022.	No adverse comments were received.
GMG	The Decommissioning Programmes and supporting documentation were sent to GMG via email on 28 October 2022.	GMG had no adverse comments to make concerning the decommissioning proposals.
Public	Public Notice published 28 October 2022.	No adverse comments were received.
Partners	The Decommissioning Programmes and supporting documentation were sent to all Section 29 Holders via email on 28 October 2022.	No adverse comments were received.

6. PROGRAMME MANAGEMENT

6.1 Project Management and Verification

A Spirit Energy project management team will manage the operations of competent contractors selected for all decommissioning activities. The team will ensure the decommissioning is executed safely, in accordance with legislation and Spirit Energy Health and Safety principles. Changes to the Decommissioning Programmes will be discussed with OPRED with any necessary approvals sought.

6.2 Post-Decommissioning Debris Clearance and Verification

The 500m safety zones and along a 100m wide corridor (50m either side) all the pipelines will be subject to a post decommissioning survey when the decommissioning activities have concluded.

It is proposed that Spirit Energy will work with OPRED and SFF on behalf of the Section 29 Holders to investigate use of an evidence-based approach to establish an acceptable clear seabed for the 500m zones. As the seabed is not in an environmentally sensitive area, it is proposed that an overtrawl be carried out to verify the PL2422 pipeline corridor between KP0.677 and KP0.689 to confirm that no snagging hazards remain. The overtrawl will be supported by a Certificate of Clearance. Evidence of a clear seabed in the wider area will also be included in the Close Out Report and sent to the Seabed Data Centre (Offshore Installations) at the Hydrographic Office.

Following completion of decommissioning activities an 'as-left' environmental survey and pipeline status survey will be carried out, with the main findings documented in the final Close Out Report.

Any oil and gas debris will be recovered from the seabed for to shore for disposal or recycling in line with existing disposal methods.

6.3 Schedule

A proposed schedule is provided in Figure 6.3.1. The activities are subject to the acceptance of the Decommissioning Programmes presented in this document and any unavoidable constraints (e.g., vessel availability) that may be encountered while executing the decommissioning activities. Therefore, activity schedule windows have been included to account for this uncertainty.

The commencement of offshore decommissioning activities will depend on commercial agreements and commitments. Spirit Energy will examine the possibility of including the offshore work in a wider campaign of subsea works to reduce costs.

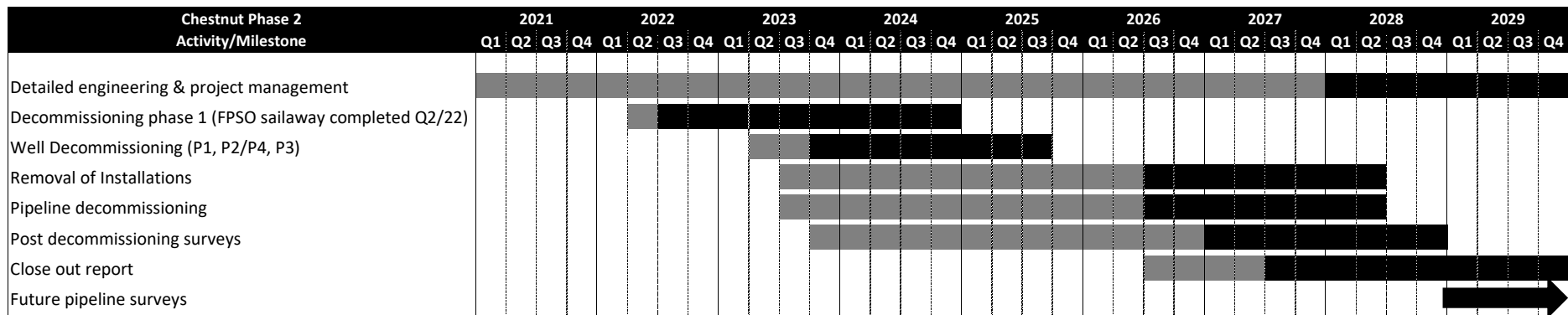

Notes / Key

Most likely period of activity [Light Grey Box]

Activity window to allow campaigning flexibility associated with decommissioning activities [Dark Grey Box]

1. The close out report will be prepared on completion of offshore activities. It will contain results of environmental surveys, debris survey (identification/removal) and clear seabed verification survey;
2. The close out report will also explain the strategy based on risk assessments and results of post decommissioning surveys.

Figure 6.3.1: Gantt Chart of project plan

6.4 Costs

Decommissioning costs will be provided separately to OPRED.

6.5 Close Out

In accordance with OPRED guidelines, a Close Out Report will be submitted to OPRED explaining any variations from the DP within 12 months of completion of the offshore decommissioning scope.

6.6 Post-Decommissioning Monitoring and Evaluation

The frequency of future surveys and the requirement for legacy and liability management will be described in the Close Out report and agreed with OPRED. The approach will be supported by a risk assessment.

It is proposed that residual liability for individual pipelines remaining *in situ* following the decommissioning works associated with these Decommissioning Programmes will remain with the respective Chestnut Section 29 Notice Holders for pipelines identified in Section 1.3.1 (Table 1.3.4). Unless agreed otherwise in advance with OPRED, Spirit Energy will remain the focal point for such matters, such as any change in ownership, for example.

The requirement for legacy and liability management will be described in more detail in the Close Out report.

7. SUPPORTING DOCUMENTS

- [1] Fugro (2022) Chestnut Pre-decommissioning Environmental Survey UKCS Block 22/02a, Volume 2 Environmental Baseline Report, 210559V2, 17 March 2022.
- [2] Genesis (2021) Chestnut Phase 2 Decommissioning Environmental Appraisal, CHESDC-GEN-S-0000-REP-0001
- [3] SENSOL (2021) Combined Decommissioning Programmes for Hummingbird Spirit FPSO Sailaway and Disconnection of Risers, CHESDC-SPT-J-0000-REP-0001.
- [4] SENSOL (2021) Chestnut pipeline decommissioning comparative Assessment, CHESDC-SPT-Z-0000-REP-0001.

APPENDIX A PREPARATORY WORKS REQUEST

Appendix A.1 Correspondence from Spirit Energy

19 August 2022

FAO Stewart Welsh
Department of Business, Energy & Industrial
Strategy
AB1 Building
48 Huntly St
Aberdeen
AB10 1SH



Spirit Energy North Sea Oil Limited

5th Floor
iQ Building
15 Justice Mill Lane
Aberdeen
AB11 6EQ

Telephone: 01224 415000
www.spirit-energy.com

Dear Stewart

Chestnut Field Preparatory Works Request

Removal of upper part of well P1 wellhead protection structure (WHPS)

The WHPS for well P1 was not installed central to the tree which means that, as part of preparatory works before commencement of well decommissioning activities, a work class remotely operated vehicle (**WROV**) cannot access the valve panel on the tree.

To ensure that the preparatory works can be carried out ahead of the execution of the well decommissioning works and in a timely manner, as operator of the Chestnut field, Spirit Energy North Sea Oil Limited (**Spirit Energy**) wishes to gain approval from OPRED for this Preparatory Works Request (**PWR**).

This PWR is submitted by Spirit Energy for and on behalf of the Joint Venture Partners for the Chestnut Installations. This is to allow part of the WHPS to be removed ahead of the approval of a formal decommissioning programme. This request will not compromise or prejudice feasible decommissioning options for the remaining part of the WHPS.

Spirit Energy is currently undertaking a study into the modifications required to the WHPS to allow a WROV to access the valve control panel in the most safe, efficient, and cost-effective manner. The operational timeframe for the WHPS modification works is 15 October to 10 November 2022, which is when the Construction Support Vessel (**CSV**) that Spirit Energy plan to use to carry out the works will be on hire.

An outline of the proposals for the modification to the WHPS for well P1 is provided herein for consideration. Should you require any further information please do not hesitate to contact at dominic.farrell@spirit-energy.com.

I would be grateful if can you acknowledge safe receipt of this letter and look forward to hearing from you in due course.

Yours sincerely

Dominic Farrell
Decommissioning Operations Manager

Spirit Energy North Sea Oil Limited
Registered in Scotland No. SC210361
Trading Address: 5th Floor, iQ Building, 15 Justice Mill Lane, Aberdeen AB11 6EQ
Registered Office: 5th Floor, iQ Building, 15 Justice Mill Lane, Aberdeen, United Kingdom, AB11 6EQ



Spirit Energy North Sea Oil Limited

Well P1 WHPS Modifications Project Information

Background

The Chestnut oil field is situated in block 22/2a of the United Kingdom Continental Shelf and operated by Spirit Energy North Sea Oil Limited (**Spirit Energy**). It is located approximately 193km East North-East of Aberdeen, in water depths of ~123m.

The field is produced via three subsea wells, supported by one subsea water injection well, tied back to a floating production, storage, and offloading (**FPSO**) installation – the Hummingbird Spirit - designed and built by Sevan Marine ASA. The installation was formerly known as the “Sevan Hummingbird”. The FPSO departed the field in June 2022.

The Chestnut field was developed as a single joint development and came onstream in late 2008. It has three production wells 21/2a-11X (**P1**), 22/2a-19Z (**P4**), 22/2a-18 (**P3**) and a water injection well 22/2a-17 which is side-tracked from 22/2a-12. Before its departure all these were tied back to the Hummingbird Spirit via flexible risers. Spirit Energy conducted well construction activities to drill and complete the Chestnut P3 well, located 85m from the existing (at the time) P2 well, in August 2017. Two of the production wells (P1 and P2) were drilled before the arrival of the Hummingbird, and the third production well (P3) was drilled in 2017 during the Chestnut Infill Well Project which was implemented to drain the additional areas of the reservoir. In March 2020, the P2 well was sidetracked to the P4 well to improve productivity.

Cessation of Production (**COP**) for the Chestnut field was accepted by the North Sea Transition Authority (**NSTA**) on 29 November 2021 and COP took place on 31st March 2022.

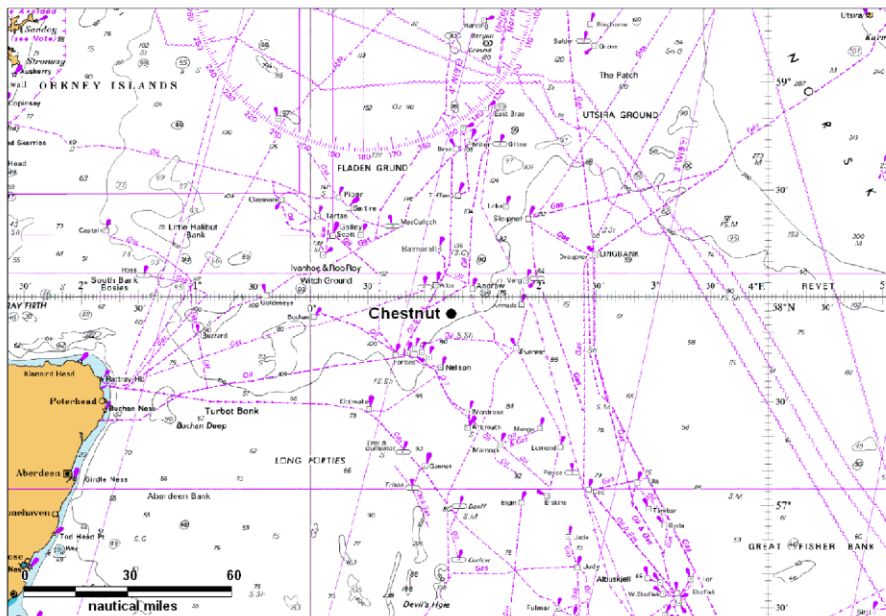

Figure 1: Chestnut field location in United Kingdom Continental Shelf

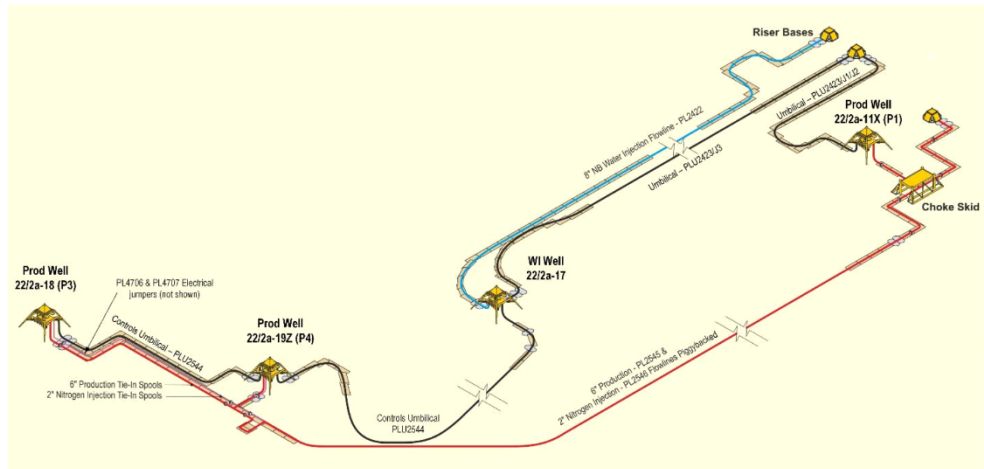

Figure 2: Chestnut infrastructure layout

The following table (Table 1) describes the Chestnut installations:

Subsea installations and associated features					
Subsea Installations Including Stabilisation Features	No.	Mass (Te)	Location		Comments/ Status
		Size (m)	WGS84 Decimal	WGS84 Decimal Minute	
P1 WHPS	1	93 16 x 16 x 6.5	57.97662°N 1.23991°E	57°58.59718N 1°14.3945E	4x 'Anchortech' 3m x 1.5m steel piles, 15.5m long (Figure 4)
P1 WHPS Anode skid	1	0.5 1.8 x 2 x 0.5			No protection frame
P2/P4 WHPS	1	58 5.7x5.7x3.3	57.9519°N 1.21525°E	57°57.11418N 1°12.91512E	Not piled
P2/P4 WHPS Anode skid	1	0.5 1.8 x 2 x 0.5			No protection frame
P3 Well WHPS	1	58 5.7x5.7x3.3	57.95218°N 1.21393°E	57°57.13105N 1°12.83604E	Not piled
P3 WHPS Anode skid	1	0.5 1.8 x 2 x 0.5			No protection frame
WI Well WHPS	1	58 5.7x5.7x3.3	57.95662°N 1.22888°E	57°57.39742N 1°13.73262E	Not piled
WI WHPS Anode skid	1	0.5 1.8 x 2 x 0.5			No protection frame

NOTES:

1. WHPS – Wellhead Protection Structure, WI – Water Injection, P1, P2, P3 – Production wells
2. No stabilisation features such as concrete mattresses, grout bags, or deposited rock are associated with the items listed above.

Table 1: Subsea installations and associated features

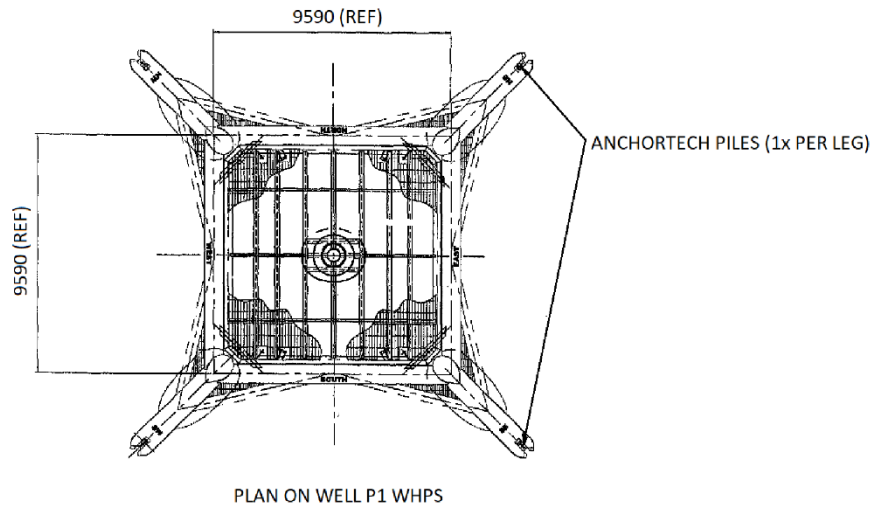

Figure 3: Well P1 WHPS

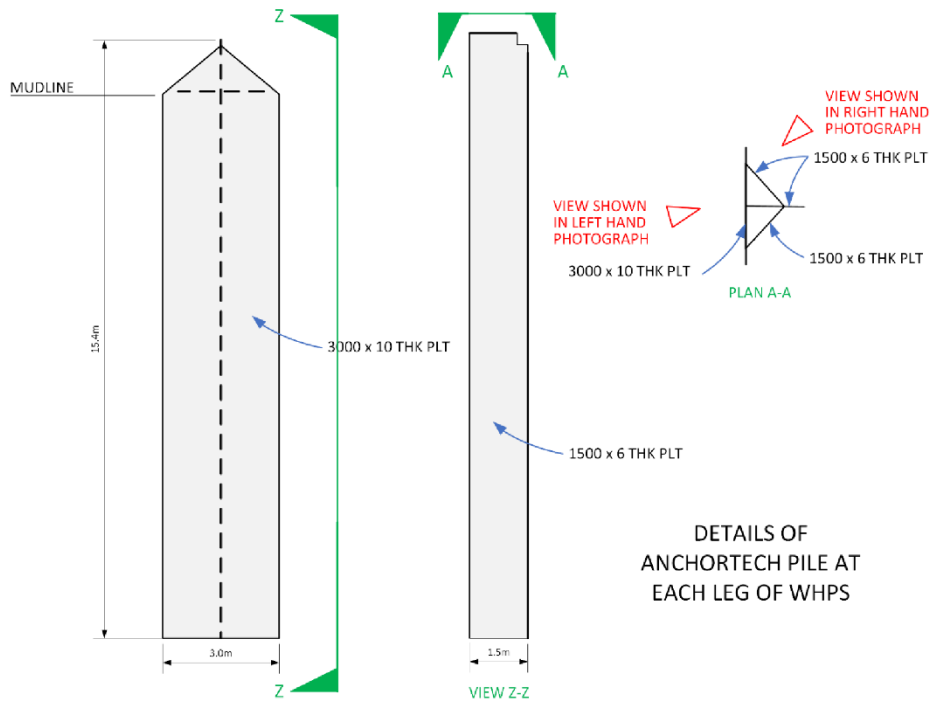

Figure 4: Well P1 WHPS 'Anchortech' piles (4x)

Description of Works & Schedule

The proposal is to cut and remove upper portion of WHPS for well P1. This will facilitate work class remotely operated vehicle (**WROV**) access to all 4 sides of the P1 tree timeously, and in advance of the future well decommissioning works planned for 2023/2024. Note that no intervention works have been carried out on well P1 since it was installed more than a decade ago.

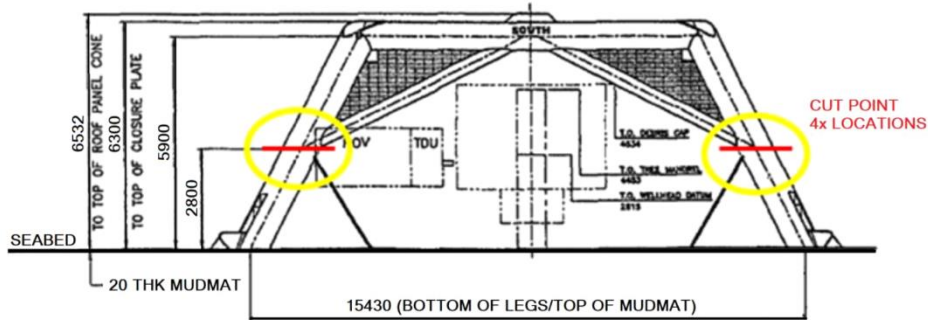

Figure 5: Well P1 WHPS –Elevation showing cut locations

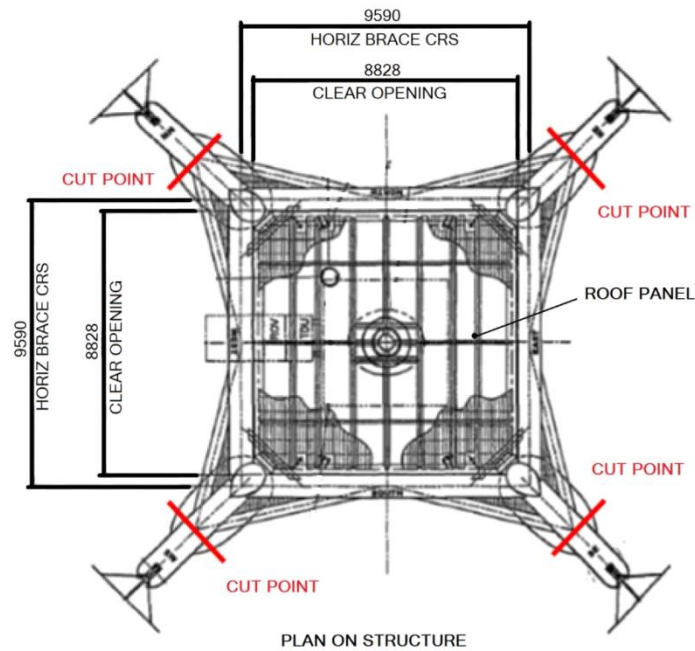

Figure 6: Well P1 WHPS –Plan showing cut locations

It is intended that the work be undertaken using a Construction Support Vessel (**CSV**) or Anchor Handling Vessel (**AHV**) – whichever is available during the riser recovery

works campaign that is scheduled for execution between 15 October to 10 November 2022.

To sever the upper part of the WHPS for well P1 it is proposed that 4x cut lines approx. 2.8m above seabed are implemented as shown in red in Figure 5 and Figure 6 above. The lower section of WHPS for well P1 including 4x mudmats and piles will remain *in situ* for recovery during the future well decommissioning works planned for 2023.

Depending on the capability of the CSV / AHV and the weather conditions, the upper section of the WHPS for well P1 will either be recovered to shore for recycling and disposal or will be left on the seabed for recovery in future along with the lower part of the WHPS.

Ongoing monitoring and protection

There is a Radar Early Warning System (**REWS**) already in place with 24hr monitoring of vessel activity in the Chestnut field. The REWS system monitors marine activity within the vicinity of offshore assets and has been designed with protocols to cater for several system failure scenarios.

On the nearby Andrew platform, the radar stations on the north-west and south-east corners are combined with two Automatic Identification System (**AIS**) receivers, and together provide 360-degree coverage with overlap of the Chestnut field.

Pre-work Justification

The WHPS for well P1 was not installed central to the tree which means that as part of preparatory works before commencement of well decommissioning activities, a WROV cannot access the valve panel on the tree.

To ensure that these preparatory works can be carried out in a timely manner and executed before the well decommissioning works scheduled for 2023, it is necessary to partially dismantle the WHPS for well P1 before the Chestnut installation decommissioning programme will likely have been approved.

On completion of the severance works OPRED will be advised of the works conducted and the fate of the upper section of the WHPS.

Appendix A.2 Correspondence from OPRED



Offshore Petroleum Regulator
for Environment & Decommissioning

Spirit Energy North Sea Oil Limited
5th Floor
IQ Building
15 Justice Mill Lane
Aberdeen
AB11 6EQ

**Offshore Petroleum Regulator for
Environment & Decommissioning**

Department for Business, Energy &
Industrial Strategy
AB1 Building
Crimon Place
Aberdeen
AB10 1BJ
T: 01224 254023
E: claire.thomson@beis.gov.uk
www.gov.uk/beis

20 September 2022

For the attention of the Managing Director

Dear Sir/Madam

**Chestnut Field Preparatory Works Request
Removal of upper part of well P1 wellhead protection structure (WHPS)**

Thank you for your letter dated 19 August 2022, in which you outline your proposal for partial removal of the Wellhead Protection Structure associated with well P1 in the Chestnut Field.

We have now reviewed this, in consultation with other interested parties, and can confirm that we are content for this work to be undertaken prior to the approval of the Chestnut Field Decommissioning Programme. Please note that should any further infrastructure with a section 29 notice need to be removed Spirit should consult with OPRED prior to the removals.

We request that you forward us an update on the works and the final fate of the Wellhead Protection Structure once the works have been completed.

Finally, please note that this scope of work should be detailed in the Chestnut Field Decommissioning Programme, stating that prior approval was obtained from OPRED on the date of this letter.

I should be grateful if you could confirm, in writing, receipt of this letter.

Yours faithfully

Claire Thomson
Decommissioning Manager
Offshore Petroleum Regulator for Environment & Decommissioning

APPENDIX B PUBLIC NOTICE & CONSULTEE CORRESPONDENCE

Appendix B.1 Public Notices

The public notices and consultee correspondence will be added following Statutory Consultation.

<p style="text-align: center;">Public Notices</p> <p style="text-align: center;">SPIRIT ENERGY NORTH SEA OIL LIMITED PETROLEUM ACT 1998 CHESTNUT FIELD DECOMMISSIONING</p> <p>Spirit Energy North Sea Oil Limited, as operator of the Chestnut field and on behalf of the Section 29 notice holders, has submitted for the consideration of the Secretary of State for Business, Energy & Industrial Strategy, a draft Decommissioning Programme for the Chestnut field in accordance with the provisions of the Petroleum Act 1998. It is a requirement of the Act that interested parties be consulted on such decommissioning proposals. The facilities covered by the Decommissioning Programme are:</p> <p>Installations</p> <ul style="list-style-type: none">• Chestnut wellhead protection structures (5x) Pipelines• Chestnut riser bases (3x)• Chestnut production well P2/P4 choke skid• Chestnut pipelines PL2421, PL2422, PLU2423, PLU2423/J1, PLU2423/J2 & PLU2423/J3; PLU2544, PL2545, PL2546, PL4706 and PL4707 <p>The Chestnut field is located approximately 193km North-East of Aberdeen.</p> <p>Spirit Energy North Sea Oil Limited hereby give notice that the Decommissioning Programme for the Chestnut field associated installations and pipelines can be viewed at internet address: https://www.spirit-energy.com/our-operations/decommissioning/</p> <p>Alternatively, a digital or hardcopy of the Decommissioning Programme can be inspected by contacting either Mr John Graham at john.graham@spirit-energy.com or Mr Dominic Farrell at dominic.farrell@spirit-energy.com.</p> <p>Interested parties are kindly requested to submit any representations in writing or electronically by 29th of November 2022 to either of the following addresses for the attention of Mr John Graham or Mr Dominic Farrell:</p> <p>Spirit Energy North Sea Oil Limited 5th Floor IQ Building, 15 Justice Mill Lane Aberdeen AB11 6EQ Date: 28th of October 2022</p>	<p style="text-align: center;">ENVIRONMENT & INFRASTRUCTURE</p> <hr/> <h2 style="text-align: center;">ENVIRONMENT & INFRASTRUCTURE</h2> <p>SPIRIT ENERGY NORTH SEA OIL LIMITED PETROLEUM ACT 1998 CHESTNUT FIELD DECOMMISSIONING</p> <p>Spirit Energy North Sea Oil Limited, as operator of the Chestnut field and on behalf of the Section 29 notice holders, has submitted for the consideration of the Secretary of State for Business, Energy & Industrial Strategy, a draft Decommissioning Programme for the Chestnut field in accordance with the provisions of the Petroleum Act 1998. It is a requirement of the Act that interested parties be consulted on such decommissioning proposals. The facilities covered by the Decommissioning Programme are:</p> <p>Installations</p> <ul style="list-style-type: none">• Chestnut wellhead protection structures (5x) Pipelines• Chestnut riser bases (3x)• Chestnut production well P2/P4 choke skid• Chestnut pipelines PL2421, PL2422, PLU2423, PLU2423/J1, PLU2423/J2 & PLU2423/J3; PLU2544, PL2545, PL2546, PL4706 and PL4707 <p>The Chestnut field is located approximately 193km North-East of Aberdeen.</p> <p>Spirit Energy North Sea Oil Limited hereby give notice that the Decommissioning Programme for the Chestnut field associated installations and pipelines can be viewed at internet address: https://www.spirit-energy.com/our-operations/decommissioning/</p> <p>Alternatively, a digital or hardcopy of the Decommissioning Programme can be inspected by contacting either Mr John Graham at john.graham@spirit-energy.com or Mr Dominic Farrell at dominic.farrell@spirit-energy.com.</p> <p>Interested parties are kindly requested to submit any representations in writing or electronically by 29th of November 2022 to either of the following addresses for the attention of Mr John Graham or Mr Dominic Farrell:</p> <p>Spirit Energy North Sea Oil Limited 5th Floor IQ Building, 15 Justice Mill Lane Aberdeen AB11 6EQ Date: 28th of October 2022 (4192675)</p> <hr/> <p style="text-align: center;">1798 CONTAINING ALL NOTICES PUBLISHED ONLINE BETWEEN 26 AND 30 OCTOBER 2022 EDINBURGH GAZETTE</p>
---	---

Table B.1.1: Public Notices: Press & Journal & The Edinburgh Gazette (publ'd 28 Oct 2022)

Appendix B.2 GMG – Mr Alex Riddell

From: John Graham <john.graham1@spirit-energy.com>

Sent: 28 October 2022 09:52

To: Riddell, Alex (Global Marine Group) <Alex.Riddell@oceaniq.co.uk>

Cc: John Mitchell, Dominic Farrell

Subject: FW: Chestnut Decommissioning Update - Phase 2 Statutory Consultation

Hi Alex,

Today, I can confirm the Public Notification for Chestnut Decommissioning - Phase 2 Statutory Consultation has been published in both the Press & Journal and the Edinburgh Gazette. The Notification published is attached to this email. This commences the statutory Consultation period. Please find links below to the relevant documents below:

Chestnut Pipeline Decommissioning Comparative Assessment CHESDC-SPT-J-0000-REP-0001 CA 2022-10-14 A3 <https://www.spirit-energy.com/media/1792/chesdc-spt-j-0000-rep-0001-ca-2022-10-14-a3-signed.pdf>

Chestnut Field Phase 2 Decommissioning Environmental Appraisal CHESDC-GEN-S-0000-REP-001 <https://www.spirit-energy.com/media/1793/chesdc-gen-s-0000-rep-001.pdf>

Decommissioning Programmes for Chestnut Field Phase 2 CHESDC-SPT-Z-0000-PRG-0002 DP 2022-10-28 A3 <https://www.spirit-energy.com/media/1794/chesdc-spt-z-0000-prg-0002-dp-2022-10-28-a3-signed.pdf>

Separately you will receive a document transmittal from our document control department, please can you return this to acknowledge receipt.

Please can you confirm that you've received all the information you require, and if you have any questions or concerns, please make any representations by 28/11/2022.

Best Regards, John A Graham, Project Manager

=====
From: Riddell, Alex (Global Marine Group) <Alex.Riddell@oceaniq.co.uk>

Sent: 09 November 2022 15:46

To: John Graham <john.graham1@spirit-energy.com>

Cc: John Mitchell, Dominic Farrell, Rygate, James (Global Marine Group)

Subject: EE: Chestnut Decommissioning Update - Phase 2 Statutory Consultation

Hi John,

Many thanks for sending through the decommissioning program of Chestnut.

I have reviewed the content provided and as the nearest active cable is located approximately 15km, I have no further comments. In the event that the decom program changes, and seabed invasive operations are to occur near existing telecom infrastructure, it will be important to notify any nearby cable owners of any upcoming operations.

Contact details of the cable owners can be sourced from <https://kis-orca.org/map/>

Kind regards, Alex Riddell

Appendix B.3 NFFO – Mr Ian Rowe, via email

From: John Graham

Sent: 28 October 2022 09:54

To: ian@nffo.org.uk

Cc: Dominic Farrell, John Mitchell

Subject: FW: Chestnut Decommissioning Update - Phase 2 Statutory Consultation

Hi Ian,

Today, I can confirm the Public Notification for Chestnut Decommissioning - Phase 2 Statutory Consultation has been published in both the Press & Journal and the Edinburgh Gazette. The Notification published is attached to this email. This commences the statutory Consultation period. Please find links below to the relevant documents below:

Chestnut Pipeline Decommissioning Comparative Assessment CHESDC-SPT-J-0000-REP-0001 CA 2022-10-14 A3 <https://www.spirit-energy.com/media/1792/chesdc-spt-j-0000-rep-0001-ca-2022-10-14-a3-signed.pdf>

Chestnut Field Phase 2 Decommissioning Environmental Appraisal CHESDC-GEN-S-0000-REP-001 <https://www.spirit-energy.com/media/1793/chesdc-gen-s-0000-rep-001.pdf>

Decommissioning Programmes for Chestnut Field Phase 2 CHESDC-SPT-Z-0000-PRG-0002 DP 2022-10-28 A3 <https://www.spirit-energy.com/media/1794/chesdc-spt-z-0000-prg-0002-dp-2022-10-28-a3-signed.pdf>

Separately you will receive a document transmittal from our document control department, please can you return this to acknowledge receipt.

Please can you confirm that you've received all the information you require, and if you have any questions or concerns, please make any representations by 28/11/2022.

Best Regards, John A Graham, Project Manager

=====
From: Ian Rowe <ian@nffo.org.uk>

Sent: 01 December 2022 15:53

To: John Graham <john.graham1@spirit-energy.com>

Subject: Re: Chestnut Decommissioning Update - Phase 2 Statutory Consultation

Hi John

I can confirm as the Chestnut is in Scottish waters NFFO have no comments regarding the proposed phase 2 decommissioning documentation.

Regards, Ian

Appendix B.4 NIFPO – Mr Wayne Sloan

NIFPO were prompted 21 November for feedback, but a response has not been received.

=====
From: John Graham <john.graham1@spirit-energy.com>

Sent: 28 October 2022 09:56

To: waynes@fpoffshoreservices.co.uk

Cc: Dominic Farrell <dominic.farrell@spirit-energy.com>; John Mitchell (c) <john.mitchell@spirit-energy.com>

Subject: FW: Chestnut Decommissioning Update - Phase 2 Statutory Consultation

Hi Wayne,

Today, I can confirm the Public Notification for Chestnut Decommissioning - Phase 2 Statutory Consultation has been published in both the Press & Journal and the Edinburgh Gazette. The Notification published is attached to this email. This commences the statutory Consultation period. Please find links below to the relevant documents below:

Chestnut Pipeline Decommissioning Comparative Assessment CHESDC-SPT-J-0000-REP-0001 CA 2022-10-14 A3 <https://www.spirit-energy.com/media/1792/chesdc-spt-j-0000-rep-0001-ca-2022-10-14-a3-signed.pdf>

Chestnut Field Phase 2 Decommissioning Environmental Appraisal CHESDC-GEN-S-0000-REP-001 <https://www.spirit-energy.com/media/1793/chesdc-gen-s-0000-rep-001.pdf>

Decommissioning Programmes for Chestnut Field Phase 2 CHESDC-SPT-Z-0000-PRG-0002 DP 2022-10-28 A3 <https://www.spirit-energy.com/media/1794/chesdc-spt-z-0000-prg-0002-dp-2022-10-28-a3-signed.pdf>

Separately you will receive a document transmittal from our document control department, please can you return this to acknowledge receipt.

Please can you confirm that you've received all the information you require, and if you have any questions or concerns, please make any representations by 28/11/2022.

Best Regards, John A Graham, Project Manager

Appendix B.5 SFF – Mr Steven Alexander & Mr Andrew Third

From: John Graham <john.graham1@spirit-energy.com>

Sent: 28 October 2022 10:04

To: Steven Alexander <S.Alexander@sff.co.uk>; Andrew Third <A.Third@sff.co.uk>

Cc: John Mitchell, Dominic Farrell

Subject: FW: Chestnut Decommissioning Update - Phase 2 Statutory Consultation

Dear Steven & Andrew,

Today, I can confirm the Public Notification for Chestnut Decommissioning - Phase 2 Statutory Consultation has been published in both the Press & Journal and the Edinburgh Gazette. The Notification published is attached to this email. This commences the statutory Consultation period. Please find links below to the relevant documents below:

Chestnut Pipeline Decommissioning Comparative Assessment CHESDC-SPT-J-0000-REP-0001 CA 2022-10-14 A3 <https://www.spirit-energy.com/media/1792/chesdc-spt-j-0000-rep-0001-ca-2022-10-14-a3-signed.pdf>

Chestnut Field Phase 2 Decommissioning Environmental Appraisal CHESDC-GEN-S-0000-REP-001 <https://www.spirit-energy.com/media/1793/chesdc-gen-s-0000-rep-001.pdf>

Decommissioning Programmes for Chestnut Field Phase 2 CHESDC-SPT-Z-0000-PRG-0002 DP 2022-10-28 A3 <https://www.spirit-energy.com/media/1794/chesdc-spt-z-0000-prg-0002-dp-2022-10-28-a3-signed.pdf>

Separately you will receive a document transmittal from our document control department, please can you return this to acknowledge receipt.

Please can you confirm that you've received all the information you require, and if you have any questions or concerns, please make any representations by 28/11/2022.

Best Regards, John A Graham, Project Manager

From: Mohammad Fahim Hashimi <f.hashimi@sff.co.uk>

Sent: 24 November 2022 18:04

To: Steven Alexander <S.Alexander@sff.co.uk>; John Graham <john.graham1@spirit-energy.com>

Cc: John Mitchell, Dominic Farrell, Andrew Third, John Spink, Elspeth Macdonald

Subject: RE: Chestnut Decommissioning Update - Phase 2 Statutory Consultation

Hi John,

Please find attached SFF's response letter on Chestnut Field Phase2 Decommissioning Programme for your consideration.

Best wishes, Fahim



Our Ref: FH/OFD/D2

Your Ref: Email dated 28 October 2022

24 November 2022

Scottish Fishermen's Federation
24 Rubislaw Terrace
Aberdeen, AB10 1XE
Scotland UK

T: +44 (0) 1224 646944
F: +44 (0) 1224 647058
E: sff@sff.co.uk

www.sff.co.uk

FAO John A Graham
Project Manager
Spirit Energy North Sea Oil Limited
5th, Floor
IQ Building
15 Justice Mill Lane
Aberdeen
AB11 6EQ

Dear John,

Chestnut Decommissioning Update - Phase 2 Statutory Consultation

I refer to the Consultation on Draft Decommissioning Programmes and key supporting documentation referred to in your email of 28 October 2022.

The Scottish Fishermen's Federation (SFF) appreciates the clearly laid out and detailed explanation of Spirit Energy decommissioning proposals for the Chestnut Field Subsea Installation and Pipelines Phase 2 Decommissioning programmes and place on record our appreciation of the information provided.

As highlighted previously, the concerns of fishermen remain primarily that of safety and the physical impact on the fishing grounds of the long-term presence of oil industry infrastructure on the seabed.

We are therefore pleased to note that in relation to installations and associated features Spirit Energy are planning for complete removal with piles associated with the WHPS for Well P1 to be cut at -1m.

In relation to sections of pipelines and umbilicals that are trenched and buried along their length, we accept the reasoning behind the recommendation of leaving these in situ with minimum intervention in order to minimise seabed disturbance. With regard to PL2422, we would take this opportunity to make the point that if any section of concrete mattress is found to be uncovered, then our recommendation would be for such localities to be spot rock dumped.

Members:

Anglo Scottish Fishermen's Association · Fife Fishermen's Association · Fishing Vessel Agents & Owners Association (Scotland) Ltd ·
Mallaig & North-West Fishermen's Association Ltd · Orkney Fisheries Association · Scottish Pelagic Fishermen's Association Ltd ·
The Scottish White Fish Producers' Association Ltd · Shetland Fishermen's Association

VAT Reg No: 605 096 748





As you will be aware, any pipelines and associated materials left on the seabed represent a legacy issue and will require on going monitoring. Where rock cover is deployed, we would look for the size and profile of the rock to follow normal industry standards and would recommend that such rock dump berms are incorporated into the post decommissioning debris clearance trawl sweeps to verify that, at the time of deposit, they did not pose a risk to fishing.

Given past experiences of both abandoned wellhead and oil and gas fields in the process of being decommissioned, the SFF would take the opportunity to reaffirm that it has serious reservations regarding the use of survey data (section 6.2 of the Decommissioning Programmes refers) to verify that an area is safe for fishing activity to resume following decommissioning activity. It is our view that the undertaking of trawl verification sweeps under controlled conditions, which replicated the fishing operations that will be permitted in the area following the decommissioning work, is the best method of establishing that it is safe for fishing to resume in said area.

As highlighted previously, detailed information regarding the SFF's Oil and Gas Decommissioning Policy and accompanying Key Principles document can be viewed via the SFF's website using the following link: <https://www.sff.co.uk/sff-offshore-oil-gas-decommissioning-policy/>.

The Federation having stated the above position, would reaffirm its appreciation of the decommissioning plans provided and its wish to work closely and positively with the Chestnut Field Decommissioning Team, as you work through the challenges before you.

Yours sincerely,

Mohammad Fahim Hashimi
Offshore Energy Policy Officer