



End-to-end system for generation and use of green hydrogen for fuel switching in ceramics manufacturing (PROGREEN H2)

Feasibility Study

20 April 2023

Report CPI-IBB27-REP-002 Rev 004



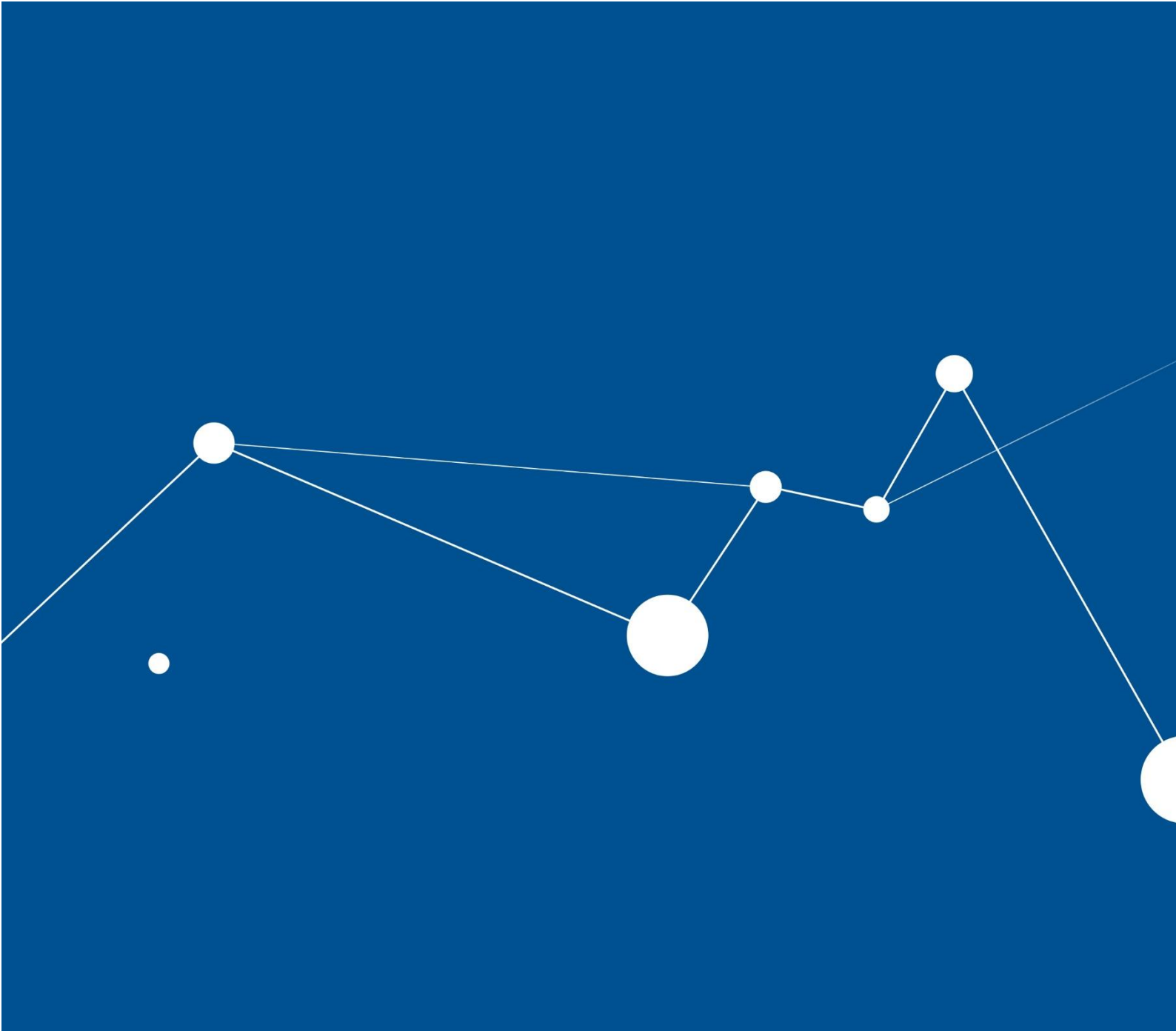

Whilst every reasonable care has been taken in preparing this report, and the information in it is believed to be accurate and reliable, it is not guaranteed or represented to be so (in either an express or implied way). The views expressed in this document are those of Centre for Process Innovation Limited ("CPI") and are based in good faith upon the specific information and data published in this report.

The information in this report may not be complete or accurate, and although the information and any views based on them is supplied in good faith, it is provided without any legal responsibility or obligation to provide future updates. The information and views contained in this report may be subject to change without notice, and as such may become out of date and unreliable at any time and will not be updated. Accordingly you should carefully consider any steps that you might chose to take in reliance on this report, and if you do take any such steps, you do so at your own risk.

If this report is a project report, it is not intended to be a full technical report of the project. It is intended to be a summary of the experiments undertaken at CPI and a collation of the resulting data.

Nothing contained in this report constitutes, or is intended to be, or shall be deemed to be, in either an express or implied way, a recommendation for investment in, or an endorsement of the financial health or present or future viability of any business, product or process, and shall not be represented publicly as such.

If this report was not prepared specifically for you by CPI, then you are NOT entitled or authorised to rely upon it in any way, and CPI shall not be legally responsible to you for the consequences of you doing so.

If this report was prepared for you, unless otherwise set out in a signed written contract between us, CPI's maximum liability to you in relation to any claim arising from or in connection with this report shall be the price that you have actually paid to CPI for this report to be prepared, and CPI hereby excludes its liability for all losses of profit (direct and/or indirect), and all indirect, consequential or other special losses (including but not limited to any third party claims or losses) in connection with any such claim. Should you disclose this report to any third party, you must make them aware that they are NOT entitled or authorised to rely upon it in any way. This report is licensed to you for your personal use only for the specific purposes that have been agreed between you and CPI.

If you are a body that is subject to the Freedom of Information Act 2000, Environmental Information Regulations 2004, and / or any other public access and or disclosure obligations, please note that much of the contents of the report contains trade secrets that may relate to patentable materials, trading activities and commercial secrets protected by legally enforceable duties of confidentiality that fall within the statutory exemptions to public disclosure. It is a condition of CPI making this report available to you that you must not make any public disclosure of this report under any such legislation without consulting CPI first and redacting all elements required by CPI that are exempt from statutory disclosure under relevant legislation.



From innovation to commercialisation

At CPI we work with partners to translate great ideas into products and processes that enhance health and well-being, protect and improve our environment and increase productivity across industries.

With a deep understanding of innovation processes and funding, outstanding technical expertise and industry relevant assets, we enable products and processes to be quickly and cost-effectively brought to market. This supports the development of next generation manufacturing, highly-skilled jobs and economic growth for the UK.

| | |
|--|--|
| Report compiled by | Michael Hughes Katie Richardson |
| Centre for Process Innovation Limited | Wilton Centre Wilton Redcar Cleveland TS10 4RF United Kingdom |
| Telephone | +44 (0)1642 455 340 |
| Website | www.uk-cpi.com |

Revision history

| Rev # | Prepared by | Checked (1) by | Approved by | Comments |
|-------|----------------|------------------|-------------|--|
| 1 | M.H. | K.R. | A.S. | Draft report compiled |
| 2 | Michael Hughes | Katie Richardson | Alex Smith | Revision incorporating comments from MO and DESNZ/BEIS |
| 3 | Michael Hughes | David Brown | Alex Smith | Revision incorporating further comments from MO and DESNZ. Public appendices added to main document. |
| 4 | David Brown | Michael Hughes | Alex Smith | Revision incorporating further comments from DESNZ. |

Contents

| | |
|---|-----------|
| Revision history | 5 |
| Contents | 6 |
| Glossary | 9 |
| 1 Executive summary | 11 |
| 2 Introduction and objectives | 14 |
| 2.1 Low carbon hydrogen production | 15 |
| 2.1.1 CCUS-enabled methane reformation | 15 |
| 2.1.2 Electrolysis | 16 |
| 2.1.3 CCUS-enabled biomass gasification..... | 16 |
| 2.1.4 Summary..... | 16 |
| 2.2 Proposed technology | 17 |
| 2.2.1 Non-thermal plasma desalination..... | 18 |
| 2.2.2 Air separation | 19 |
| 2.2.3 Non-thermal plasma ammonia production | 19 |
| 2.2.4 Intermediate separation | 19 |
| 2.2.5 Ammonia storage / transport..... | 20 |
| 2.2.6 Catalytic membrane ammonia cracking..... | 20 |
| 2.2.7 Hydrogen storage | 21 |
| 2.2.8 Ceramic kiln | 21 |
| 3 Feasibility study..... | 22 |
| 3.1 Experimental and modelling results | 22 |
| 3.2 Performance..... | 24 |

| | | |
|----------|---|-----------|
| 3.2.1 | Mass balance | 24 |
| 3.2.2 | Efficiencies | 25 |
| 3.2.3 | Emissions reduction | 26 |
| 3.3 | Economic assessment | 27 |
| 3.3.1 | Capital costs..... | 27 |
| 3.3.2 | Operating costs..... | 29 |
| 3.3.3 | Levelised cost of hydrogen | 30 |
| 3.3.4 | Alternative case..... | 32 |
| 3.4 | Comparison to alternative low carbon hydrogen production technologies | 37 |
| 3.4.1 | Efficiencies | 37 |
| 3.4.2 | Emissions | 39 |
| 3.4.3 | Levelised cost of hydrogen | 40 |
| 3.5 | Ceramic kiln design and modifications | 42 |
| 3.6 | Comparison to alternative ceramic kiln decarbonisation options | 44 |
| 3.7 | Technical and regulatory feasibility..... | 45 |
| 3.8 | Questionnaire Responses..... | 48 |
| 4 | Stream 2B delivery plan..... | 51 |
| 5 | Value and benefits..... | 52 |
| 5.1 | Social value | 52 |
| 5.2 | Benefits derived through contract | 52 |
| 5.3 | Knowledge dissemination and engagement..... | 54 |
| 5.4 | Enabling fuel switching | 54 |
| 5.5 | Assessment of future potential..... | 54 |
| 6 | Conclusions and recommendations | 56 |
| 7 | References..... | 58 |

Appendices62

Glossary

| | |
|-------------------|---|
| ASU | Air separation unit |
| ATEX | Explosive atmosphere (<i>Atmosphères Explosibles</i>) |
| ATR | Autothermal reformer |
| BEIS | Department for Business, Energy & Industrial Strategy |
| CAPEX | Capital expenditure |
| CCUS | Carbon capture utilisation and storage |
| CH ₄ | Methane |
| CO | Carbon monoxide |
| CO ₂ | Carbon dioxide |
| CO ₂ e | Carbon dioxide equivalent |
| CPI | Centre for Process Innovation |
| DESNZ | Department for Energy Security and Net Zero |
| EAL | Environmental Assessment Level |
| FEED | Front end engineering design |
| GHG | Greenhouse gas |
| GHR | Gas heated reformer |
| HHV | Higher heating value |
| LCHS | Low Carbon Hydrogen Standard |
| LCOH | Levelised cost of hydrogen |
| LHV | Lower heating value |
| m ³ | Cubic metre |
| MW | Megawatt |
| MWh | Megawatt-hour |
| Nm ³ | Normal cubic metre |
| NO _x | Nitrogen oxides |
| NPV | Net present value |
| NTP | Non-thermal plasma |

| | |
|--------------------------------------|---|
| OPEX | Operational expenditure |
| PEM | Proton exchange membrane |
| PFD | Process flow diagram |
| Ru/La-Al ₂ O ₃ | Ruthenium / Lanthanum - Aluminium oxide |
| Ru/MgO | Ruthenium / Magnesium oxide |
| SMR | Steam methane reformer |
| SOE | Solid oxide electrolysis |
| TWh | Terawatt-hour |
| µg | Microgram |

1 Executive summary

The UK ceramic industry produces a wide range of products including bricks, roof tiles, drainage pipes, wall tiles, tableware, giftware, sanitary ware, and refractories. It accounted for approximately £2 billion in annual sales including £0.5 billion in exports in 2017. The sector is energy-intensive and consumes around 4.7 TWh of delivered energy per year, with gas accounting for 80 to 82% of the industry's overall energy mix and total emissions in 2012 were 1.2 million tonnes of CO₂.

Decarbonising the ceramic industry by switching to green hydrogen will contribute to the UK meeting its CO₂ mitigation targets. The advantage of using hydrogen as a fuel is that it produces water instead of CO₂ as a combustion by-product. However, hydrogen has a high adiabatic flame temperature, which results in increased nitrogen oxide emissions, and it also has a lower heating value on a volumetric basis, which means that higher volumetric flowrates are required for firing, compared to other fuels. These differences may pose specific challenges to the ceramic industry, especially regarding burner design and the impact on the final product in terms of its physical, chemical, and mechanical characteristics.

This report summarises the feasibility study for the PROGREEN H2 project funded under Stream 2A of the Industrial Hydrogen Accelerator programme by the Department for Energy Security and Net Zero (DESNZ), previously the Department of Business, Energy and Industrial Strategy (BEIS). This work was undertaken by a consortium comprising of the Centre for Process Innovation (CPI), Lucideon, University of Hull, University of Sheffield, and Newcastle University.

The objectives of the study were to determine the feasibility of the end-to-end process that converts sea water and nitrogen (from the air) into hydrogen (via ammonia as an intermediate) to be used as an alternative fuel in the ceramic industry. The proposed process consists of several novel technologies that are still in early stages of development. These processes have been combined into a complete system based on the information available in open literature. At project initiation, sea water was proposed as a feedstock as it would allow for point of use hydrogen production, eliminating the requirement for costly hydrogen transport networks and reduce demand on freshwater delivery network. Using ammonia as an intermediate (rather than direct conversion of water to hydrogen) removes the safety concerns associated with storage of hydrogen as it can be produced on demand from stored ammonia.

The capital and operating expenses associated with this system have been estimated and used to develop a techno-economic analysis assessment. The outcomes of this assessment show that the process in its current form is not economically viable. The levelised cost of hydrogen produced in the process is more than 2000 times higher than any of the alternative low carbon hydrogen production technologies.

The main reason for this is the very low conversion of nitrogen to ammonia (approximately 0.03%) in the non-thermal plasma ammonia production step. This results in a very large recycle of unreacted nitrogen gas and requires significant capital and operating expenses to accommodate this recycle. The catalysts developed at the University of Hull and tested at Newcastle University did not show a large enough improvement to change the outcome of the study.

As a result of this, the overall system is not at a stage where it can proceed to a FEED study or demonstration scale plant. Further fundamental research is necessary to evaluate whether the nitrogen conversion to ammonia can be improved to a level where the entire process can be economically viable. Key to this will be identifying, developing and testing alternative catalysts that can improve the nitrogen conversion and lower the electrical power requirements.

An alternative case was considered that takes in ammonia as a feedstock and only makes use of the hydrogen production and combustion section of the proposed process. This eliminates the inefficient non-thermal plasma steps in the production of ammonia and as a result provides a more viable technology option. This would build on the operating model of having a central ammonia production facility, but then transporting the ammonia to site to produce the hydrogen for use. This on-demand system, via NH₃, eliminates the cost and safety concerns associated with hydrogen storage and transportation at high pressure. The key consideration for this case will be the source of the ammonia to ensure that the emissions associated with its production are low and the source of energy is renewable.

While this alternative case improves the economic viability of the process, it still results in a levelised cost of hydrogen of more than two times any of the alternative low carbon hydrogen technologies.

Lucideon and Therser constructed a burner test stand to enable the testing of firing a kiln with 100% hydrogen. Successful firing using 100% hydrogen resulted in approximately 94% less CO₂ content in the flue gas, while there was an increase of approximately 2.5 times more NO_x content. Using the results of these tests, designs for pilot-scale kilns for temperatures of 1300 °C and 1750°C were developed.

Based on these results the use of hydrogen in the ceramics industry as a fuel for kiln burners is feasible. Various modifications would be required to existing kilns to allow for the combustion of hydrogen by the burners. These modifications will be specific to each site and type of kiln and the costs associated with these modifications will vary accordingly.

The ceramics industry still has a number of concerns around the health, safety and planning requirements associated with the switch to the hydrogen fuel. Other concerns include the cost of

the modifications as well as the impact that the hydrogen combustion and associated increase in moisture will have on the final ceramic product. The pilot-scale kilns will be used in future to test fire a variety of ceramic products to improve the understanding of the impact of firing these products using 100% hydrogen.

2 Introduction and objectives

This report summarises the feasibility study for the PROGREEN H2 project funded under Stream 2A of the Industrial Hydrogen Accelerator programme by the Department for Energy Security and Net Zero (DESNZ), previously the Department of Business, Energy and Industrial Strategy (BEIS) (1). This work was undertaken by a consortium comprising of the Centre for Process Innovation (CPI), Lucideon, University of Hull, University of Sheffield and Newcastle University.

The UK ceramic industry produces a wide range of products including bricks, roof tiles, drainage pipes, wall tiles, tableware, giftware, sanitary ware and refractories. It accounted for approximately £2 billion in annual sales including £0.5 billion in exports in 2017 (2). Based on a 2012 study by the British Ceramic Confederation (2), the sector is energy-intensive and consumes around 4.7 TWh of delivered energy per year, with gas accounting for 80 to 82% of the industry's overall energy mix. It also found that total emissions in 2012 were 1.2 million tonnes of CO₂.

Decarbonising the ceramic industry by switching to green hydrogen will contribute to the UK meeting its CO₂ mitigation targets and achieving the goals set out in the UK Hydrogen Strategy 2021 (3). The advantage of using hydrogen as a fuel is that it produces water instead of CO₂ as a combustion by-product. However, hydrogen has a high adiabatic flame temperature, which results in increased nitrogen oxide emissions, and it also has a lower heating value on a volumetric basis, which means that higher volumetric flowrates are required for firing, compared to other fuels. These differences may pose specific challenges to the ceramic industry, especially regarding burner design and the impact on the final product in terms of its physical, chemical and mechanical characteristics.

The objectives of the study were to determine the feasibility of the end-to-end process that converts sea water and nitrogen (from the air) into hydrogen (via ammonia as an intermediate) to be used as an alternative fuel in the ceramic industry. The chosen scale of the facility would allow for the energy input into the kiln of 3 MW (LHV H₂).

The work was split into a number of work packages utilising the expertise of the various partners in the consortium as follows:

- WP 1 - Validation and concept design for Non Thermal Plasma (NTP) desalination and ammonia synthesis steps, including design and optimisation of catalysts (led by Universities of Hull and Sheffield)
- WP2 - Modelling, optimisation, and validation of ammonia cracking process (led by Newcastle University)

- WP3 – Build and run burner test stand to facilitate future kiln design with 100% hydrogen, as well as understand and document the modifications required to an existing kiln and burner system to accommodate 100% hydrogen firing (led by Lucideon).
- WP4 – techno-economic analysis, conceptual design and feasibility study of PROGREEN H2 prototype/demonstration system (led by CPI).
- WP5 - Project management and knowledge dissemination (led by CPI)

2.1 Low carbon hydrogen production

There are various low carbon technologies available to produce hydrogen. Each of these has advantages and disadvantages and, depending on the configuration, some are not viable in terms of the scale required for individual ceramic producers. These will be used to compare the performance of the PROGREEN process from an economic, energy efficiency and emissions reduction perspective.

2.1.1 CCUS-enabled methane reformation

Typically, hydrogen is produced from the reformation of methane using either steam methane reforming (SMR) or auto-thermal reforming (ATR) technologies. In both cases, methane-rich gas is converted into hydrogen and a mixture of CO and CO₂. The difference between the two technologies is that for the Autothermal Reformer (ATR), oxygen is introduced into the reactor to allow for the combustion of some of the feed. This allows for the ratio of hydrogen to CO₂ to be varied.

The addition of carbon capture utilisation and storage (CCUS) technologies allow for the removal of the majority of the CO₂ produced in the process. However, this technology is still expensive and requires CO₂ transportation and storage infrastructure to be in place.

Methane reforming facilities are typically large (100s of MW scale) and do not tend to allow for the flexibility in ramping up and down production. These facilities would need to be installed in a central location and generate hydrogen that is then transported to the individual industrial consumers. This would require a dedicated network of pipelines, or road/rail tankers.

2.1.2 Electrolysis

Electrolysis is the process of using electricity to split water into hydrogen and oxygen. Electrolysis plants are generally modular and these modules (or stacks) can be combined to provide larger capacities if required. Currently, stack sizes are typically up to 5 MW in size.

Alkaline electrolysis is the most mature form of electrolysis with around 90 years of operational experience. The reaction that separates the water into hydrogen and oxygen occurs between two electrodes in a solution composed of water and liquid electrolyte.

Proton Exchange Membrane (PEM) electrolysis splits water by using an ionically conductive solid polymer. It also offers rapid ramp up and turn down to follow energy output. It is ideal for pairing with, for example, dedicated wind farms for low carbon hydrogen production or the provision of rapid response to the grid.

Whilst alkaline and PEM electrolysis are both low-temperature technologies, Solid Oxide Electrolysis (SOE) uses high-temperature electrolysis (500 degrees centigrade). SOE is not yet widely available commercially but does show higher efficiencies when compared to other electrolysis technologies.

2.1.3 CCUS-enabled biomass gasification

Hydrogen can also be produced via gasification of a solid feedstock, such as coal or biomass. The synthetic gas (syngas) is produced in an oxygen deficient atmosphere (to avoid combustion) comprising of air, oxygen or steam. Hydrogen is then separated out of the syngas. Biomass feedstocks can include almost any organic material including woody and herbaceous, agricultural waste, commercial waste and dry sewage waste.

CCUS technologies can be added to allow for the removal of the majority of the CO₂ produced in the process. Again, this technology is still expensive and requires CO₂ transportation and storage infrastructure to be in place.

2.1.4 Summary

Taking into consideration some criteria or preferences for hydrogen generation for the ceramic industry, **Table 1** provides a comparison of these more established technologies. Generally,

electrolysis would be a more suitable technology option for on-site hydrogen generation for the ceramic industry.

Table 1. Comparison of established low carbon hydrogen production technologies

| Criteria | CCUS enabled methane reforming | Electrolysis | CCUS enabled biomass gasification |
|--|--------------------------------|--------------|-----------------------------------|
| Small scale options | x | ✓ | x |
| Availability of fuel | ✓ | ✓ | x |
| No requirement for CO ₂ transport & storage | x | ✓ | x |
| Ease of ramping up and down | x | ✓ | x |

The disadvantages of utilising electrolysis to generate hydrogen include the fact that fresh water is required, putting pressure on the freshwater resources.

Table 1 compares the technologies based on a number of criteria that would be relevant, should the ceramic producer prefer to produce the hydrogen on site. However, an alternative model would be to procure hydrogen produced at a centralised facility that would then transport the hydrogen to site. This would open up the methane reforming and biomass gasification technologies as more attractive, however current limitations in terms of the hydrogen transportation network would still need to be overcome.

2.2 Proposed technology

The proposed system consists of a number of technology blocks that are integrated into a hydrogen production and, ultimately, a hydrogen combustion step. This can be seen in more detail in the simplified block flow diagram shown in **Figure 1**. The details of each block are discussed in the following sections. Process flow diagrams showing further details of each step can be found in Appendix 9.

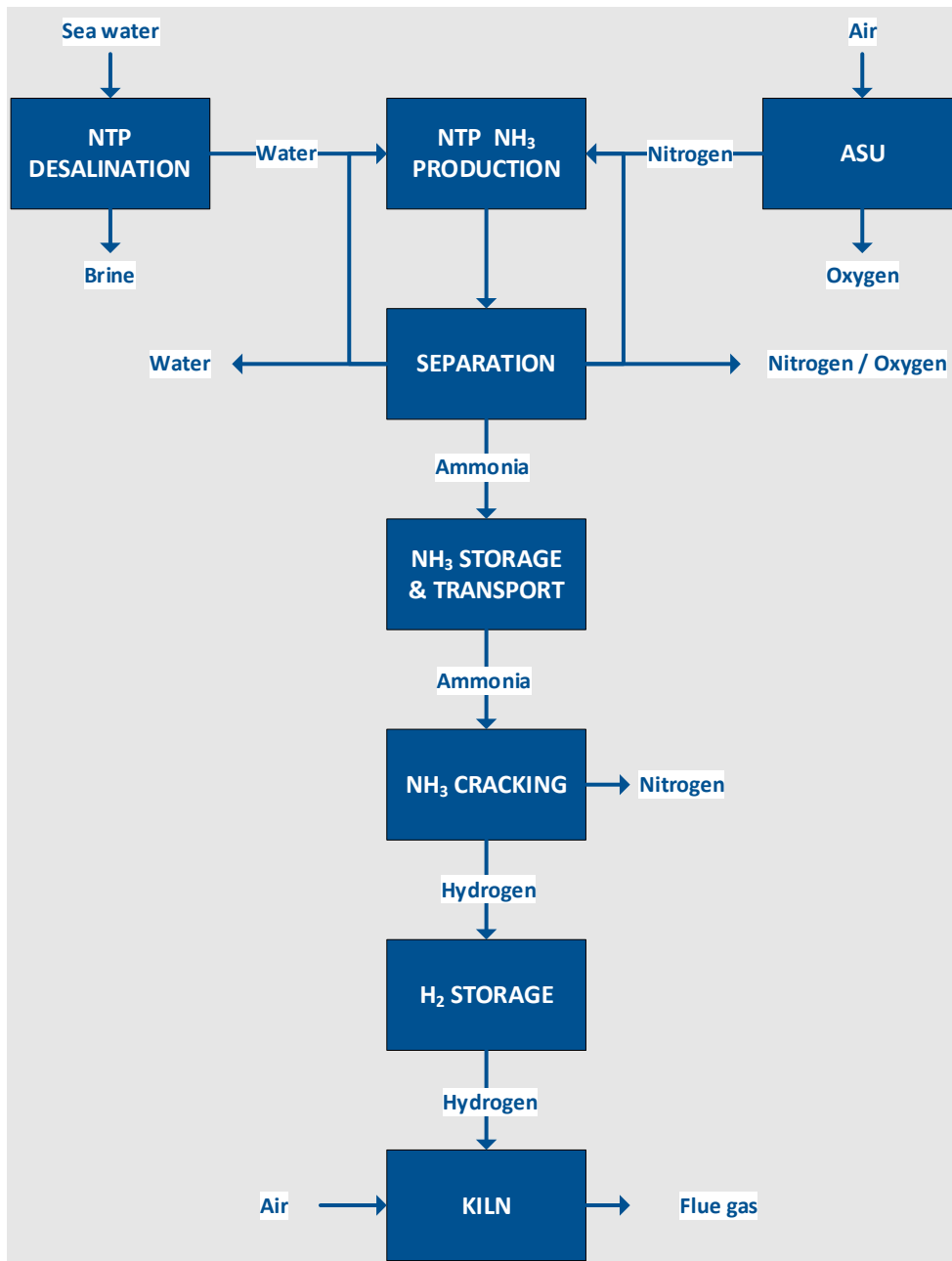

Figure 1. Simplified block flow diagram of proposed process.

2.2.1 Non-thermal plasma desalination

The first processing step is the desalination of sea water to provide fresh water to the downstream units. Sea water will be extracted and treated with a non-thermal plasma technology that requires air and an electrical current to operate (4). The air plasma jet/s allow the non-equilibrium evaporation of the water at a pressure of 1 bar(a) and temperature of 75 °C. This evaporated water is then condensed to form the freshwater product for the downstream units.

The residual brine solution is diluted with sea water so that the discharge stream has a salinity value only 5% above the background marine salinity¹.

2.2.2 Air separation

The non-thermal plasma ammonia production unit requires nitrogen as a feedstock. Due to the high flow rates required, cryogenic distillation is the preferred technology option.

2.2.3 Non-thermal plasma ammonia production

Nitrogen and fresh water are supplied to the ammonia production unit. The nitrogen feed is a combination of fresh nitrogen and a large recycle from downstream. Similarly, the water feed is a mixture of the fresh water from the desalination unit and a large recycle from downstream separation.

Nitrogen is humidified by passing it through the water, resulting in a vapour phase feed stream. This saturated feed is then sent through a water-cooled single dielectric barrier discharge reactor that is packed with Ru/MgO catalyst (5). Energy provided by the electrical current splits the water molecules into oxygen and hydrogen atoms. These then react in the gas phase, as well as on the catalyst surface, together with the nitrogen to generate ammonia and nitrous oxide.

The outlet of the reactor consists of a mixture of unreacted nitrogen and water vapour, along with the reaction products of ammonia and nitrous oxide. These need to be separated in the intermediate separation unit.

2.2.4 Intermediate separation

In order to store and utilise the ammonia produced in the previous step; it needs to be separated from the mixture of products from the ammonia production unit. First, the water is removed by compressing and cooling the gas. The majority of the separated water is then recycled back to the ammonia production unit.

¹ The UK Environment Agency does not provide any environmental quality standards for salinity or chlorides in estuaries and coastal waters (21). The 5% increase in salinity over background levels is based on limits from Western Australia and reflect similar limits of increasing salinity by less than 1-2 parts per thousand (20).

Thereafter, the remaining gas sent to a rectifying column to remove the ammonia product. The liquid ammonia is then transferred to a storage unit until the downstream units require the feedstock.

The remaining nitrogen rich gas is split, with the majority recycled back to the ammonia production unit, while a purge stream will be routed through a nitrous oxide decomposition reactor to remove the nitrous oxide, prior to being vented to atmosphere.

2.2.5 Ammonia storage / transport

The storage of the ammonia intermediate product is necessary for two reasons:

- The desalination and ammonia production units may be located at a different location to where the ammonia cracking and ceramic kiln is sited.
- The hydrogen consumption in the ceramic kiln may be non-continuous

Therefore, the liquid ammonia produced in the intermediate separation step is stored in cooled and pressurised vessels. Transportation of this liquid ammonia will be required, most likely via road tanker.

2.2.6 Catalytic membrane ammonia cracking

The ammonia from the previous steps is fed into the ammonia cracking unit, where the feed material passes through a catalytic membrane reactor packed with Ru/La-Al₂O₃ catalyst (6). The hydrogen that is produced passes through the membrane surrounding the catalyst and is swept away using steam as a sweep gas. This steam is generated from fresh water that will need to go through a demineralisation step via reverse osmosis.

The hydrogen/water product stream is then cooled to allow the water to be separated from the hydrogen product. Unreacted ammonia and nitrogen product exits the reactor and is treated using a sulphuric acid scrubber to remove the ammonia to below the current Environmental Assessment Level (EAL) (7) of 180 µg/m³, before being vented to atmosphere.

2.2.7 Hydrogen storage

Due to either fluctuating hydrogen production or consumption, some form of buffer storage capacity will be required.

2.2.8 Ceramic kiln

The hydrogen produced in the ammonia cracking step will be fed to the ceramic kiln. For a demonstration unit, the kiln would be a new kiln specially built for the purpose. Should this process be implemented on an existing site, the burners in the kiln would need to be modified to run on hydrogen fuel. The hydrogen would be combusted in the presence of air to generate water vapour and heat to fire the ceramic products and reducing or eliminating the CO₂ emissions which would previously have been generated by the CH₄ combustion.

3 Feasibility study

The following section provides a summary of the findings of the feasibility study. Further details can be found in the appendices.

3.1 Experimental and modelling results

Ruthenium-based catalysts have been used in the synthesis of ammonia in the KBR Advanced Ammonia Process (KAAP) since 1992. They show between 10-20 times higher activity, than traditional magnetite-based catalysts and allow for less severe operating conditions (8). The University of Hull were able to prepare a number of metal oxide supported ruthenium catalyst materials, using a liquid-phase chemical reduction method (see Appendix 1 for more details). These included Ru/SiO₂, Ru/Al₂O₃, Ru/Mg(OH)₂ and Ru/MgO and were characterised using various spectroscopic and microscopic techniques. These catalyst materials were sent to Newcastle University to test them in a laboratory-scale non-thermal plasma reactor system.

Newcastle University tested the Ru/Al₂O₃ catalyst in a laboratory-scale dielectric barrier discharge reactor system (see Appendix 2 for more details). The performance of the reactor filled with a mixture of the catalyst and barium titanate was compared to only barium titanate. Barium titanate is a ferroelectric material with a very high dielectric constant and allows for intensification of the plasma discharge within the reactor.

The results from the catalyst testing showed that the catalyst increased the nitrogen conversion to ammonia by 27 times over the reactor with only barium titanate. The increase in electrical power applied to the reactor also showed an improvement in nitrogen conversion. When comparing the nitrogen conversion of using the new catalyst to other studies in literature (5), there appeared to be a slight improvement (approximately 15%). However, the space velocity used to achieve these conversions are not the same, making an objective comparison very difficult.

Newcastle University have developed models of the packed-bed membrane reactor for catalytic ammonia decomposition into hydrogen (see Appendix 2 for more details). The models were used to determine the impact several variables had on the performance of the reactor. These variables included the operating pressure and temperature. The results showed that operating at higher pressures (up to 10 bar(a)), lower temperatures (down to 230 °C) and lower space velocities showed an improvement in the hydrogen production over the reactor. These results can be used for further optimisation of the reactor conditions.

Lucideon and Therser constructed a burner test stand to enable the testing of firing a kiln with 100% hydrogen (see Appendix 5 for more details). The design of the kiln was aided by the use of Computational Fluid Dynamics (CFD) to determine the flow distribution within the kiln. **Figure 2** shows the test kiln used for the burner tests.



Figure 2. Burner test kiln constructed by Therser UK

The results of the tests showed that a hydrogen flow rate of 15.2 Nm³/h was possible through the burner, with a maximum temperature of 965 °C achieved after 2.5 hours. **Figure 3** shows the key differences in the flue gas composition after firing the kiln with 100% hydrogen and then natural gas. At a similar temperature (where they overlap between 750-825 °C), firing using 100% hydrogen results in approximately 94% less CO₂ content in the flue gas, while there is an increase of approximately 2.5 times more NO_x content.

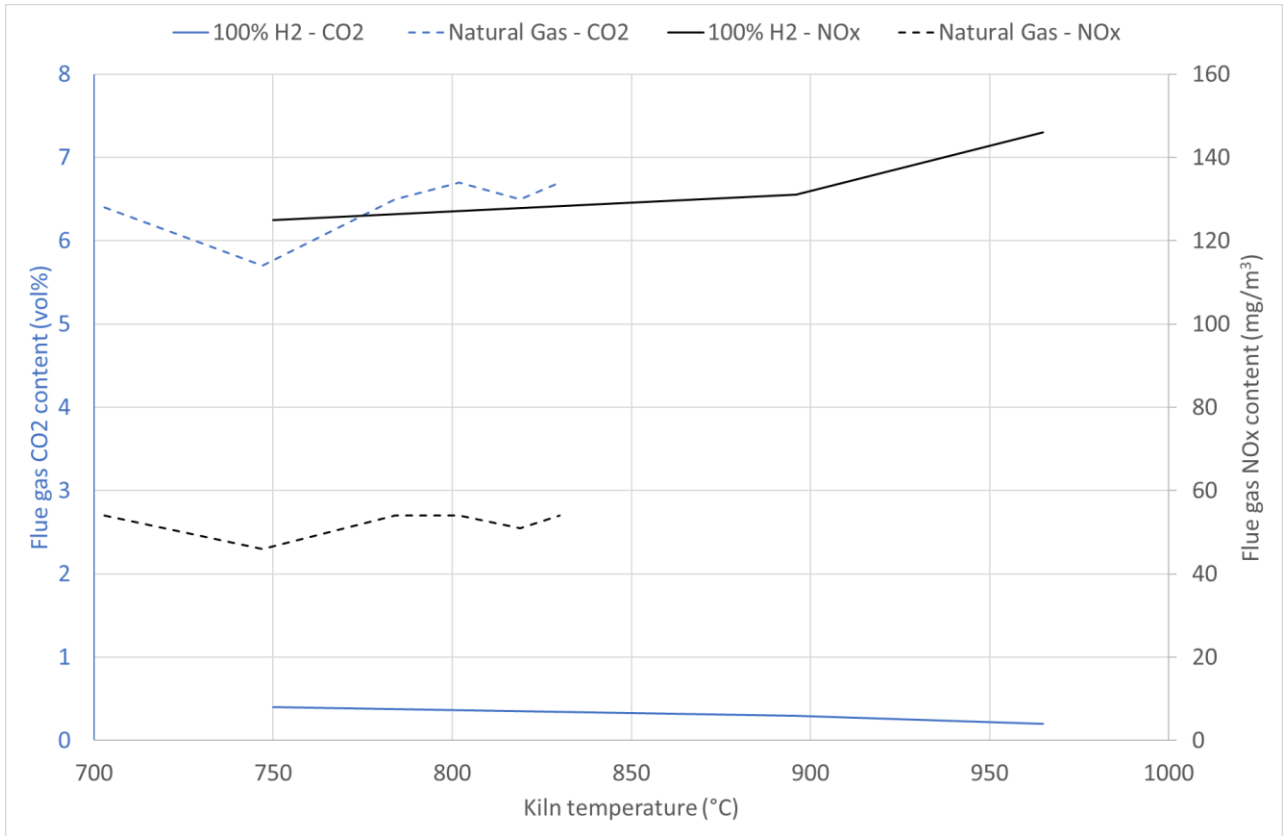

Figure 3. Key results from the hydrogen kiln tests (see Appendix 5 for more details)

3.2 Performance

3.2.1 Mass balance

In order to understand the overall performance of the technology, a very high-level mass balance has been provided in **Table 2**. The inputs to the process are mainly air and sea water, although some fresh water is required, as this is necessary for the ammonia cracking step, not located near the desalination unit at the coast. The small amount of sulfuric acid is required for an ammonia scrubber to mitigate unconverted ammonia emissions.

Table 2. Overall mass balance of the 3 MW (LHV H₂) PROGREEN process

| IN | | OUT | |
|----------------------------|---------|-------------------------------|---------|
| Stream | kg/h | Stream | kg/h |
| Sea water | 53,893 | Sea water | 195 |
| Air | 142,915 | Brine | 51,176 |
| Fresh water | 1,907 | Air | 3,856 |
| Concentrated sulfuric acid | 91 | Oxygen | 31,676 |
| 0.1M Sodium hydroxide | 2 | Nitrogen | 105,181 |
| | | Water | 1,545 |
| | | Neutralised scrubber effluent | 2,024 |
| | | Flue gas (water vapour) | 3,154 |
| Total | 198,808 | Total | 198,808 |

The main products are nitrogen and oxygen, as a result of the separation of air to produce the nitrogen for the ammonia production step. The large quantities of nitrogen produced are due to the very low nitrogen conversion in the ammonia production step and needing to purge some of the very large recycle stream. More detailed tables of individual stream flows can be found in the mass and energy balance calculations in Appendix 10.

3.2.2 Efficiencies

The proposed process is complex with a number of interconnected sub-processes. Each of these has its own conversion and efficiency value. Firstly, the plasma desalination step has a yield of 75% of desalinated water and an electrical efficiency of 2140 kWh/m³ of desalinated water (4).

The second major step is the ammonia production step. This has a very low nitrogen conversion of only 0.0297% with a high electrical requirement of 15394 kWh/kg of ammonia (5). This is a critical step in the process and the low nitrogen conversion and high electricity requirement has a large impact on the overall process efficiency. This low nitrogen conversion value is typical for this type of process with values ranging from 0.0003% to 0.042% (9), while the electrical requirement can also range widely from 1500 to 125000 kWh/kg of ammonia (9) (5). The variation in conversion and electricity requirement is due to the system design, whether a catalyst and/or electrolyte is used, as well as the type of reactor used.

The third step is the ammonia cracking step. This step has favourable ammonia conversion rates of approximately 95% (6). The complete combustion of the hydrogen occurs in the kiln, with excess air ensuring this takes place.

The overall PROGREEN process efficiency takes into account the total amount of electricity required to produce the hydrogen product. This has been calculated to be 2886 kWh_e/kWh_{HHV} H₂ or only 0.03% of the electrical energy is recovered as heating value in the hydrogen used as the fuel in the ceramic kiln. Further details into the process efficiency calculations can be found in Appendix 15.

3.2.3 Emissions reduction

As mentioned above, most of the kilns used in the ceramic industry are fired using natural gas. According to the 2021 conversion factors provided by BEIS for greenhouse gas reporting (10), the combustion of natural gas as a fuel emits approximately 0.2 kgCO_{2e} per kWh of net calorific value. The table below compares this to the emissions of the proposed PROGREEN hydrogen system. Further details of the calculations can be found in Appendix 16.

Table 3. GHG emissions comparison between natural gas and PROGREEN H₂

| | Natural Gas | PROGREEN H ₂ (wind/solar) | PROGREEN H ₂ (grid) |
|--|-------------|---|--------------------------------|
| Fuel type used in kiln | Natural gas | Hydrogen | Hydrogen |
| gCO _{2e} / MJ _{LHV, fuel} | | 0.3 | 114387 |
| kg CO _{2e} / kWh _{LHV, fuel} | 0.20297 | 0.0011 | 411.8 |
| Annual tonnes CO _{2e} for 3 MW kiln | 4,871 | 25.9 | 9,883,007 |

Due to the very high electricity requirements of the proposed technology, it is clear that if grid electricity is used, the PROGREEN technology will emit far higher amounts of greenhouse gases than the current natural gas process. However, should renewable electricity from a wind or solar source be utilised, the greenhouse gas emissions will be significantly reduced when compared to

the current natural gas combustion. This shows that the electricity source plays an important role in defining the emissions from the technology.

3.3 Economic assessment

The economic assessment discussed below is only for the demonstration scale facility producing hydrogen for combustion in a 3 MW LHV H₂ ceramic kiln.

3.3.1 Capital costs

An integrated flowsheet has been developed that combines all of the key processing steps at a process flow diagram level (see Appendix 9 for more detail). This was used as the basis for the capital cost estimates presented in this section.

The capital costs for the various pieces of equipment were determined using various sources of information, including quotations, online prices, and cost curves from several references (11), (12), (13). These were scaled and escalated to 2020 costs where necessary. Further details of these calculations can be found in Appendix 12.

A breakdown of the equipment purchase costs for the 3 MW (LHV H₂) scale PROGREEN facility is given in **Table 4** below. It is clear that these costs for a demonstration-scale facility are very high and this is due to the very low nitrogen conversion achieved in the ammonia production facility. This results in a very large recycle stream around this processing step, requiring multiple pieces of equipment (heat exchangers, compressors and knock-out vessels) in parallel in the intermediate separation section to accommodate the flow rates.

Table 4. Breakdown of equipment purchase costs for the various sections of the 3 MW (LHV H₂) PROGREEN facility

| Processing step | Equipment purchase cost (£, 2020) |
|-------------------------|-----------------------------------|
| Desalination | 169,251 |
| Ammonia production | 190,990,269 |
| Intermediate Separation | 1,304,965,462 |
| Ammonia Cracking | 806,354 |
| Hydrogen Storage | 1,791,347 |
| Kiln | 953,657 |
| Total | 1,499,676,340 |

The values in **Table 4** are only the equipment purchase costs. When scaled with appropriate factors to account for additional costs (e.g., piping, electrical, instrumentation), the total fixed capital costs are given in **Table 5**. Due to the high likelihood that the facility would need to be split between two sites into the ammonia production facility near the coast and then the hydrogen production and combustion facility on site at a ceramics manufacturer, the costs have been split as such in **Table 5**. It is clear that the ammonia production facility would account for the vast majority of the cost of the overall facility, again due to the very low nitrogen conversion, resulting in very high recycle rates and associated equipment requirements.

Table 5. Total fixed capital cost for a 3 MW (LHV H₂) PROGREEN facility

| Section | Cost (£, 2020) |
|---------------------------------|----------------|
| Ammonia production plant | 8,232,427,714 |
| Hydrogen production and storage | 14,495,171 |
| Ceramic firing | 4,770,670 |
| Total | 8,251,693,555 |

The catalysts identified for use in the process make use of rare and expensive materials (e.g., ruthenium) and these also have a high cost associated with them, both from an initial capital cost outlay for the first fill of the reactors, but then also for the continuous replacement of the catalyst due to deactivation.

3.3.2 Operating costs

The operating costs for the demonstration scale facility were also based on the flowsheet and mass balance developed at the PFD level of detail. Further details of these calculations can be found in Appendix 11.

The electricity demand was based on the power requirements for various pieces of equipment, including pumps, compressors and electrical heaters. However, the bulk of the electricity requirement is due to the plasma reactors. The cooling water requirements were based on the cooling duties determined using the mass and energy balances over each of the coolers. The other variable costs were the minor material costs that include the acids and alkali materials for the ammonia scrubber.

The fixed operating costs were based on the capital costs using standard factors (13), as well as estimates for labour based on the complexity of the process.

Table 6 shows the breakdown of the operating costs associated with the entire process. The majority of the variable costs (>97%) are due to the high electricity requirements of the non-thermal plasma ammonia production step. This is again due to the very low nitrogen conversion achieved in this step and the high power requirement per kg of ammonia produced. This electricity demand is approximately 10 GW, or roughly one third of the entire Great British network demand.

Table 6. Operating expenses summary

| OPEX | Expense | Annual Cost (£,2020) |
|----------------|---------------------------|----------------------|
| Variable Costs | Raw Materials | 18,603,449 |
| | Miscellaneous Materials | 82,516,936 |
| | Utilities - Electricity | 4,087,334,755 |
| | Utilities – cooling water | 854,100 |
| Fixed Costs | Maintenance | 825,169,356 |
| | Operating labour | 399,672 |
| | Supervision | 79,934 |
| | Plant Overheads | 199,836 |
| | Insurance | 82,469,229 |
| | Local Taxes | 164,938,458 |
| Total | | 5,262,565,724 |

The maintenance costs were estimated as a factor of the CAPEX and as a result this makes up the bulk (>75%) of the fixed OPEX.

3.3.3 Levelised cost of hydrogen

In order to compare the cost of different types of hydrogen production technologies, BEIS used a metric called the levelised cost of hydrogen (LCOH) in a report published in 2021 (14). It is the discounted cost of building and operating a production facility and is expressed as a cost per energy unit of hydrogen produced (£/MWh_{H₂}). It is defined as the ratio of the total costs of the plant to the total amount of hydrogen expected to be produced over the plant's lifetime.

The total costs of the plant include the construction and equipment costs (CAPEX) and the fixed and variable operating expenses, including CO₂ transport and storage, fuel and electricity, as well as carbon costs (OPEX). Also taken into account is the capacity of the plant and its expected efficiency and online utilisation. The net present values of the total costs and hydrogen production are calculated according to **Equation 1** and **Equation 2**.

$$NPV \text{ of Total Costs} = \sum_n \frac{\text{Total CAPEX and OPEX}_n}{(1 + \text{discount rate})^n} \quad n = \text{time period} \quad \text{Equation 1}$$

$$NPV \text{ of H2 Production} = \sum_n \frac{\text{Hydrogen Production}_n}{(1 + \text{discount rate})^n} \quad n = \text{time period} \quad \text{Equation 2}$$

The levelised cost of hydrogen is then calculated using **Equation 3**.

$$LCOH = \frac{NPV \text{ of Total Costs}}{NPV \text{ of H2 Production}} \quad \text{Equation 3}$$

This methodology was used to determine the LCOH for the various cases evaluated in this study (see Appendix 17 for more details). These are provided in **Figure 4** below.

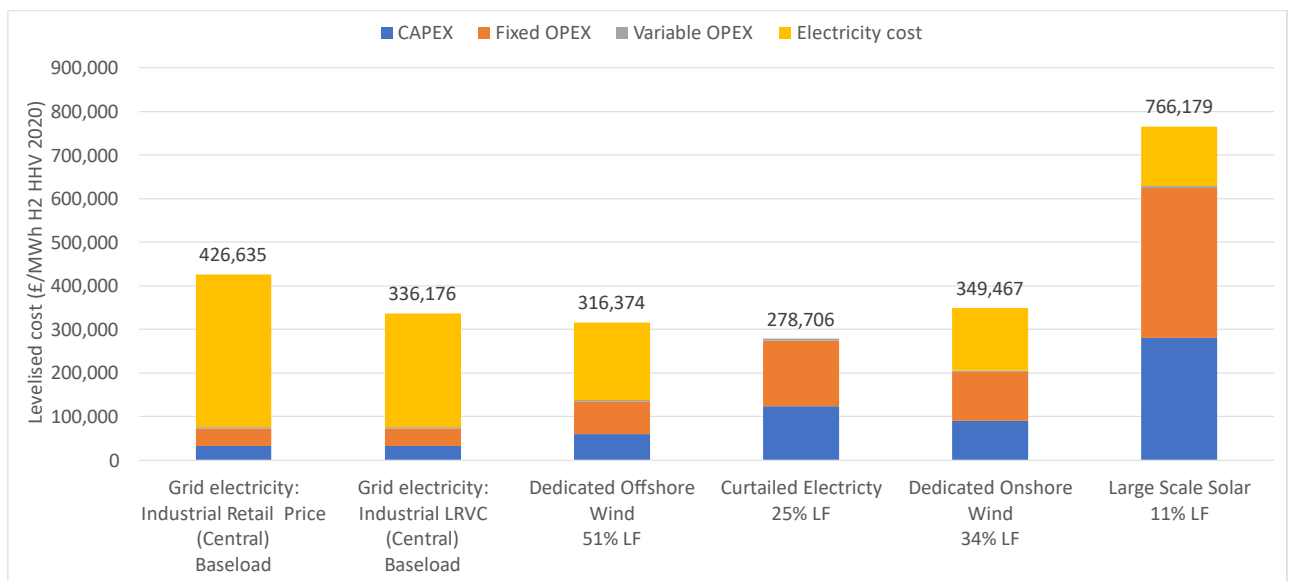

Figure 4. Comparison of the Levelised Cost of Hydrogen for the PROGREEN process using various sources of electricity

These costs are extremely high as they take into account all of the costs, including the high capital costs as well as the electricity requirements. It is clear that if grid electricity is used, the capital cost contribution is lower, due to the higher load factor assumption of 95%. However, the cost of the electricity makes up the majority of the cost of the hydrogen.

If lower cost electricity is utilised (e.g., onshore wind or large scale solar), the electricity cost is lower, but the capital costs are significantly higher. This is due to the low load factor assumptions

for these technologies, requiring larger hydrogen production facilities to make up for the time spent offline.

3.3.4 Alternative case

From the analysis above, the main cause of the high capital and operating costs is the ammonia production facility. If one were to remove that section of the plant and focus only on the hydrogen production and combustion site, the viability of the process improves significantly. This would mean that the facility would need to source ammonia and then crack the ammonia into hydrogen and nitrogen and feed the hydrogen into the burners of the kiln. **Figure 5** shows a simple block flow diagram of this alternative case.

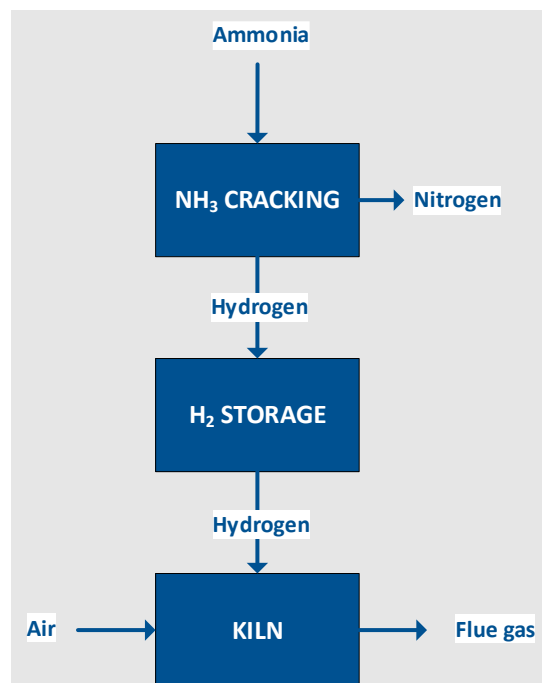

Figure 5. Simple BFD of the alternative PROGREEN case

A similar process for hydrogen production has been evaluated by a consortium including Ecuity, Engie, Siemens and the Science & Technology Facilities Council (15). They found that cracking ammonia on site is more economically favourable than cracking it centrally and then transporting the hydrogen to the various consumers. This can be seen in **Figure 6**, where the total cost for centralised cracking of ammonia and transportation of the hydrogen would be £198.7/MWh, while the decentralised model of transporting the ammonia to site and then cracking the ammonia to hydrogen would cost £141.7/MWh, for a distance of 100 km. The major difference is the additional cost of compression of the hydrogen prior to transport, as well as the higher transportation and storage costs of the hydrogen.

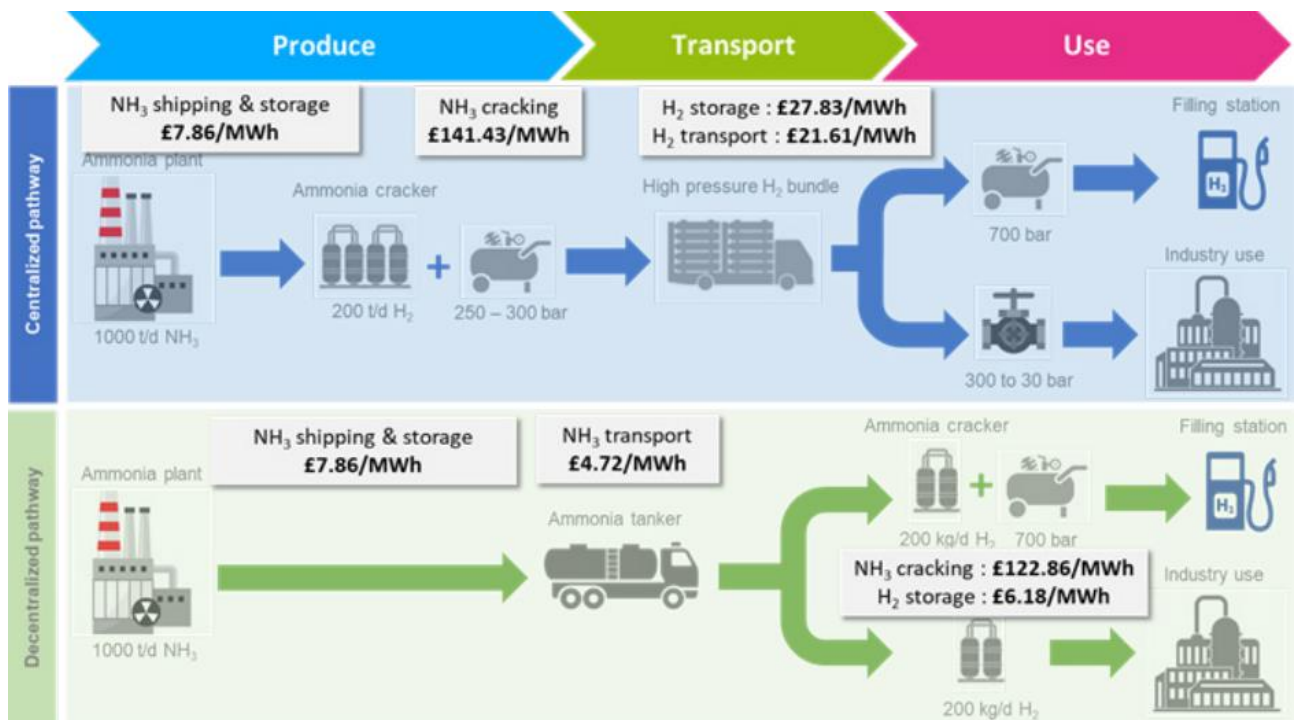

Figure 6. Centralised and decentralised strategies for ammonia decomposition (15)

Based on this information, the decentralised model would be more attractive for this alternative case using ammonia as a feedstock.

The efficiency of the process would be significantly improved, up to 80% as shown in **Table 7**, with the largest inefficiency due to the thermal energy conversion from the ammonia to hydrogen. Further details can be found in Appendix 15.

Table 7. Efficiency estimates for the alternative case of feeding ammonia into the hydrogen production facility of the PROGREEN process

| Technology | Thermal Efficiency | Electrical Efficiency | NH3 production efficiency contribution | Overall Efficiency | Overall Efficiency % |
|---|-------------------------------------|-----------------------|--|--------------------|----------------------|
| | kWh input fuel or heat / kWh H2 HHV | kWhe/ kWh H2 HHV | kWh/ kWh H2 HHV | kWh/ kWh H2 HHV | % |
| PROGREEN | | 2886 | | 2886 | 0.03 |
| PROGREEN (alternative case) | 1.09 | 0.13 | | 1.23 | 81.4 |
| PROGREEN (alternative case - NG reformed NH3) | 1.09 | 0.13 | 1.36 | 2.59 | 38.6 |
| PROGREEN (alternative case - renewable NH3) | 1.09 | 0.13 | 1.75 | 2.98 | 33.6 |

The values in the second row in **Table 7** do not include the efficiency of the ammonia production step as this can vary, depending on the technology used to produce the ammonia. Energy consumption values vary from 28 GJ/tonne of ammonia for natural gas steam reforming, to 42 GJ/tonne of ammonia for coal fed partial oxidation (16). Renewable ammonia has an energy consumption value in the range of 10-12 kWh/kg of ammonia (17). The final two rows in **Table 7** show the impact of these energy requirements on the overall efficiency of the process. The overall efficiency is more than halved but is still significantly improved over the PROGREEN base case.

The on-site emissions from this alternative case will be zero if renewable sources of electricity are used. However, the source of the ammonia would impact the overall GHG intensity of the process, with CO₂ emissions for ammonia production ranging from 1.6 to 3.8 kgCO₂/kgNH₃ for steam reforming of natural gas, and partial oxidation of coal, respectively (16). Sourcing the ammonia from a process that makes use of renewable energy would reduce these carbon emissions.

Table 8 provides a comparison of the GHG emissions intensity for the alternative PROGREEN case against the current natural gas combustion. The impact of the source of the electricity and the source of the ammonia is shown. It is clear that in order to meet the Low Carbon Hydrogen Standard (LCHS) of 20.5 gCO₂e/MJ_{LHV,H2}, electricity would need to be sourced from wind or solar farms and that renewable ammonia would need to be used as a feedstock.

Table 8. Emissions comparison for alternative PROGREEN case

| | Emissions intensity | | Annual tonnes CO ₂ e for 3 MW kiln |
|---|----------------------------|--------------------------------|---|
| | gCO ₂ e/ MJ LHV | kg CO ₂ e / kWh LHV | tCO ₂ e/a |
| Natural Gas | | 0.20 | 4871 |
| Wind/solar electricity | | | |
| Alternative PROGREEN H2 | 0 | 0.00 | 0.00 |
| Alternative PROGREEN H2 (Natural Gas sourced NH ₃) | 92 | 0.33 | 7955 |
| Alternative PROGREEN H2 (Electrolysis sourced NH ₃) | 0 | 0.00 | 0.00 |
| Grid electricity | | | |
| Alternative PROGREEN H2 | 5.3 | 0.02 | 458 |
| Alternative PROGREEN H2 (Natural Gas sourced NH ₃) | 97 | 0.35 | 8413 |
| Alternative PROGREEN H2 (Electrolysis sourced NH ₃) | 127 | 0.46 | 11015 |

In terms of CAPEX requirements for this alternative case, this would be the £19 million as estimated for the hydrogen production, storage and ceramic kiln of the overall PROGREEN facility in **Table 5** in Section Capital costs 3.3.1. This is significantly less than the whole PROGREEN process, however it does not include the off-site capital costs that would be required by the ammonia supplier.

The OPEX requirements are given in **Table 9**. There is an increase in the raw material cost to the facility due to the cost of the ammonia (in this case a price of £830/tonne has been used for renewable ammonia (18)). However, there is a significant reduction in the utilities requirement (mostly electricity) and the maintenance costs, that results in more than a 600-fold decrease in the operating expenditure of the facility.

Table 9. Operating expenditure for alternative case utilising ammonia as a feedstock

| OPEX | Expense | Annual Cost (£, 2020) |
|----------------|-----------------------------------|-----------------------|
| Variable Costs | Raw Materials (including ammonia) | 4,271,490 |
| | Miscellaneous Materials | 192,658 |
| | Utilities - Electricity | 182,855 |
| | Utilities - Cooling water | 131 |
| Fixed Costs | Maintenance | 1,926,584 |
| | Operating labour | 399,672 |
| | Supervision | 79,934 |
| | Plant Overheads | 199,836 |
| | Insurance | 192,658 |
| | Local Taxes | 385,317 |
| Total | | 7,837,650 |

The LCOH values for the alternative case can be seen in **Figure 7**. Again, there has been a significant reduction in the LCOH for the overall process, due to the removal of the very inefficient ammonia production step. There is a larger contribution in this case of the variable OPEX, which is due to the cost of the ammonia feedstock.

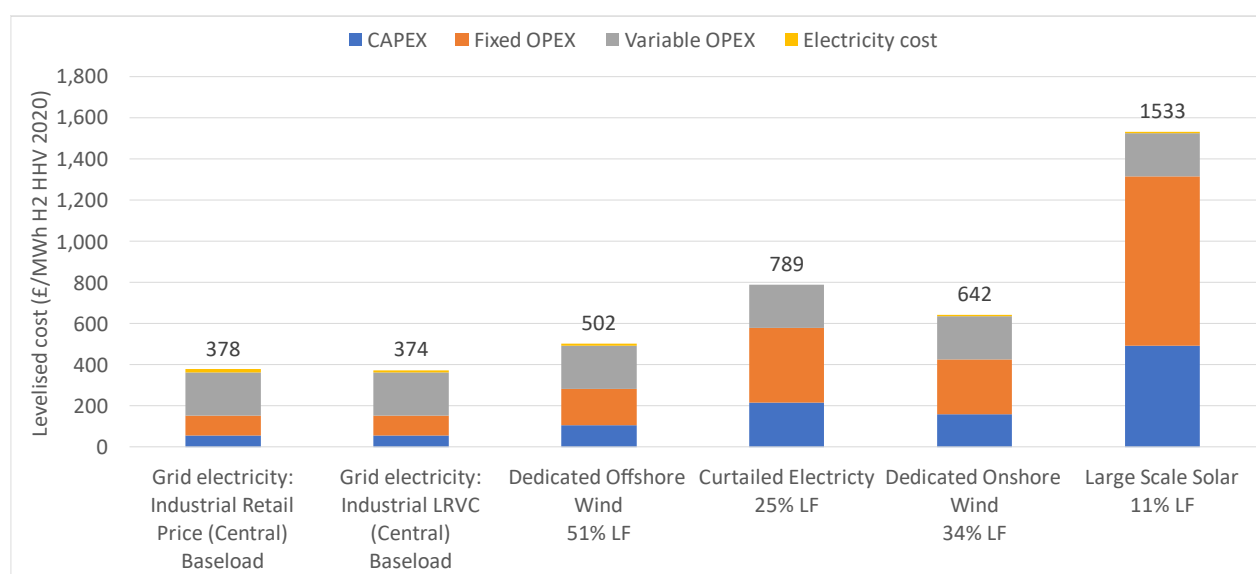

Figure 7. Levelised cost of hydrogen for the alternative case using ammonia as a feedstock, for various sources of electricity supply

3.4 Comparison to alternative low carbon hydrogen production technologies

As discussed in Section 2.1, various alternative low carbon hydrogen generation technologies are available, and the relative merits have been evaluated. Using the information generated in this feasibility study and discussed in Sections 3.1 to 3.3, it is possible to compare the proposed technology with these alternatives.

3.4.1 Efficiencies

As discussed in Section 3.2.2, the efficiency of the PROGREEN process has been evaluated from a chemical conversion as well as an electrical conversion perspective. It is possible to use the same, or similar, metrics to allow for a comparison to the alternative low carbon hydrogen technologies.

Since some of the alternative technologies convert a fuel (either natural gas or biomass) into hydrogen, these are typically evaluated based on their thermal conversion efficiency. The ATR technology also makes use of some electrical energy and so a portion of the energy input contributes to the electrical conversion efficiency. Most of the electrolysis technologies only utilise electrical energy and so they are evaluated on an electrical conversion efficiency. As a result of these two types of efficiency metrics, a fair comparison can only be made when taking into account both efficiencies.

The efficiencies of the alternative technologies were taken from the Hydrogen Production Costs report by BEIS (14). Using these and the efficiencies discussed in Section 3.2.2, a comparison is shown in **Table 10**.

Table 10. Comparison of efficiencies of PROGREEN and other alternative low carbon technologies for hydrogen production

| Technology | Thermal Efficiency | Electrical Efficiency | NH ₃ production Efficiency | Overall Efficiency | Overall Efficiency |
|---|--|---|--|--|--------------------|
| | kWh input fuel or heat / kWh _{HHV} H ₂ | kWhe/ kWh _{HHV} H ₂ | kWh/ kWh _{HHV} H ₂ | kWh/ kWh _{HHV} H ₂ | % |
| Electrolysis: Alkaline | | 1.27 | | 1.27 | 78.7 |
| Electrolysis: PEM | | 1.32 | | 1.32 | 75.7 |
| Electrolysis: SOE | 0.34 | 0.96 | | 1.30 | 76.8 |
| SMR with CCUS | 1.36 | | | 1.36 | 73.8 |
| ATR with CCUS | 1.20 | 0.06 | | 1.26 | 79.6 |
| ATR with GHR with CCUS | 1.12 | 0.04 | | 1.16 | 86.4 |
| Biomass Gasification with CCUS | 1.54 | | | 1.54 | 65.0 |
| PROGREEN | | 2886 | | 2886 | 0.03 |
| PROGREEN (alternative case) | 1.09 | 0.13 | | 1.23 | 81.4 |
| PROGREEN (alternative case – Natural Gas reformed NH ₃) | 1.09 | 0.13 | 1.36 | 2.59 | 38.6 |
| PROGREEN (alternative case - renewable NH ₃) | 1.09 | 0.13 | 1.75 | 2.98 | 33.6 |

It is clear that the process efficiency of the PROGREEN technology is very low. A large amount of electrical energy is required to produce a small amount of hydrogen. This is due to the very low conversion of nitrogen in the ammonia production step.

The alternative case of the PROGREEN technology (i.e., purchasing ammonia and using it as a feedstock in the hydrogen production step) appears to be much more in line with the alternative technologies with an efficiency of >80%. However, this efficiency does not take into account the efficiency of the off-site ammonia production process that the producer makes use of to provide the ammonia. The final two rows of **Table 10** show the updated efficiency values if this is considered. The efficiencies of these cases are still below the alternative low carbon hydrogen production technologies.

From an efficiency point of view, electrolysis technologies or ATRs with GHR and CCUS are more attractive and should rather be considered as hydrogen production technologies for the ceramics industry.

3.4.2 Emissions

The emissions from the alternative technologies (Electrolysis, CCUS enabled methane reforming and CCUS enabled biomass gasification) were estimated based on information from the BEIS Hydrogen Production Cost report for 2021 (14) and the BEIS Greenhouse gas reporting conversion factors for 2021 (10).

The emission values discussed in Section 3.2.3 for the PROGREEN technology are compared with those from the alternative hydrogen production technologies in **Table 11** below. Further details can be found in Appendix 16.

Table 11. Comparison of process emissions of PROGREEN against alternative low carbon hydrogen production technologies (in kgCO₂e/kWh_{LHV})

| | Wind / Solar | Grid Electricity |
|---|-------------------------------|-------------------------------|
| | kgCO ₂ e / kWh LHV | kgCO ₂ e / kWh LHV |
| Natural Gas | 0.20 | 0.20 |
| Alkaline | 0.00 | 0.32 |
| PEM | 0.00 | 0.33 |
| SOE | 0.07 | 0.32 |
| SMR (with CCUS) | 0.03 | 0.03 |
| ATR (with CCUS) | 0.01 | 0.03 |
| Biomass gasification (with CCUS) | 0.003 | 0.003 |
| PROGREEN H2 | 0.0011 | 411.8 |
| PROGREEN H2 (alternative) | 0.00 | 0.02 |
| PROGREEN H2 (alternative - NG reformer NH ₃) | 0.33 | 0.35 |
| PROGREEN H2 (alternative - Electrolysis NH ₃) | 0.00 | 0.46 |

From **Table 11**, it is clear that if grid electricity is used, the PROGREEN technology has a significantly higher GHG emissions value, with the most promising being biomass gasification (with CCUS). This is due to the very high electrical energy requirement of the PROGREEN

technology and the GHG emissions associated with the grid electricity. This means that the hydrogen produced in the base case PROGREEN process will not meet the Low Carbon Hydrogen Standard (LCHS) of 20.5 gCO₂e/MJ_{LHV,H₂} (or 0.0738 kgCO₂e/kWh_{LHV,H₂}).

However, should renewable electricity be utilised from wind or solar farms, the emissions values for the PROGREEN technology are significantly reduced and it becomes one of the lower emission options, with the small emissions as a result of transporting the ammonia between sites. The lowest values are associated with Alkaline and PEM electrolysis technologies that only make use of electricity as their power source.

The alternative PROGREEN case also looks promising due to the relatively low electricity requirement, and if renewable electricity is used, the emissions will be zero. However, if grid electricity is used, or the ammonia is sourced from fossil fuels, the hydrogen produced will not meet the LCHS. No emissions for ammonia transportation are included in this case due to the uncertainty of the source of the ammonia and the ceramic manufacturer site.

3.4.3 Levelised cost of hydrogen

As discussed in Section 3.3.3, the levelised cost of hydrogen (LCOH) produced using the PROGREEN process has been estimated for various sources of electricity. These costs can then be compared to the LCOH values produced by BEIS in their 2021 hydrogen production costs report (14).

Table 12 below shows the LCOH values for various alternative low carbon hydrogen production technologies using grid electricity at the industrial retail price. These are compared to the LCOH values estimated for the 3.5 MW (HHV H₂) PROGREEN facility. It is important to note that these assume an implementation date of 2025 (except for the biomass gasification facility, which would have an implementation date of 2030), but are based on 2020 real costs.

Table 12. LCOH (in £/MWh HHV H₂) of PROGREEN compared to alternative low carbon hydrogen technologies using grid electricity at the industrial retail price (central assumption (14))

| | Alkaline (10 MW) | PEM (10 MW) | SOE (10 MW) | SMR with CCUS (300 MW) | ATR with CCUS (300 MW) | ATR+GHR with CCUS (300 MW) | Biomass Gasification with CCUS (59 MW) | PROGREEN (3.5 MW) | PROGREEN (Alternative case) (3.5 MW) |
|--------------------------|------------------|-------------|-------------|------------------------|------------------------|----------------------------|--|-------------------|--------------------------------------|
| CAPEX | 10 | 10 | 19 | 10 | 12 | 12 | 38 | 32492 | 57 |
| Fixed OPEX | 4 | 4 | 7 | 3 | 3 | 3 | 13 | 39904 | 95 |
| Variable OPEX | 4 | 3 | 10 | 0 | 0 | 0 | 8 | 3602 | 209 |
| Electricity cost | 154 | 161 | 117 | 0 | 7 | 5 | 0 | 350637 | 16 |
| Gas fuel cost | 0 | 0 | 0 | 40 | 36 | 33 | 54 | 0 | 0 |
| Heat cost | 0 | 0 | 0 | 0 | 0 | 0 | 0 | 0 | 0 |
| CO ₂ T&S cost | 0 | 0 | 0 | 6 | 6 | 5 | 13 | 0 | 0 |
| Carbon cost | 0 | 0 | 0 | 2 | 1 | 1 | -56 | 0 | 0 |
| Total LCOH | 172 | 178 | 153 | 62 | 65 | 60 | 126 | 426635 | 378 |

From **Table 12**, it is clear that the LCOH for the PROGREEN technology as it currently stands is very high and makes it unattractive for the ceramic industry to consider. The alternative PROGREEN case has a much lower LCOH, even taking into account the cost of purchasing the ammonia as a feedstock. This is due to the significant reduction in capital expenditure and electricity requirement for this case.

The methane reforming technology offers a much more attractive LCOH, but at a much larger scale. It is unlikely that individual ceramics manufacturers would consider a hydrogen production facility of this scale and so it would need to be built and funded in collaboration with multiple organisations.

Although the LCOH for electrolysis is still higher than the methane reforming route, it is still much lower than the PROGREEN technology and it also can be installed at much more manageable capacities for individual manufacturers to consider on their sites.

3.5 Ceramic kiln design and modifications

The evaluation presented in the sections above refers to the demonstration-scale facility and assumes that a new kiln would be procured for the demonstration phase (see Appendix 6 for more information on kiln design). Modifications required to convert existing kilns from a 100% natural gas feed to a 100% hydrogen feed will depend on a number of factors based on the scale and type of kiln. For example, the following modifications were identified and observations made to convert a 1750 °C pilot-scale kiln running on natural gas, to running on 100% hydrogen:

- Upgrade gas train to larger diameter to accommodate greater hydrogen flow volume
- Upgrade hydrogen gas pipework to stainless steel
- Change all gas train components (valves, pressure governors etc) to hydrogen/ATEX rated
- Integrate emergency shut off valve in the hydrogen gas train which is integrated into hydrogen leak detectors
- Existing flame failure devices are suitable for hydrogen applications
- Existing 7 therm burners are rated for 100% hydrogen use
- The existing hot face refractory lining is suitable for the operating temperature
- Modifications will be required to the refractory structure around the burner mounting to account for the higher flame temperature
- A cooling air stream will be installed to manage burner quartz temperature
- The existing heat exchanger will be utilised to recuperate hot air to achieve higher operating temperatures
- The combustion air fan will be upgraded with VSD control

Burner modifications are dependent on the specific burner, some burners are already tested to 100% hydrogen. Other burner modifications include changes to the core of the burner to adjust the shape of the flow of gas as the hydrogen has significantly different burning characteristics to that of methane, for example it has an increased flame speed.

The above list of modifications are backed up by similar observations in another BEIS-funded study, Hy4Heat (19), where the following areas were identified as requiring modifications for commercial-scale facilities:

- Fuel distribution system – replacing and upgrading the distribution piping
- Combustion Air system & Flue Gas Recirculation – This would be required to mitigate the increased NO_x emissions
- Burner system – The burners would typically need to be replaced to accommodate the increased fuel volume and thermal loading.

- Post combustion system & Flue Gas Treatment – Depending on the NO_x emissions, methods such as selective catalytic reduction may be required to lower the NO_x content in the flue gas.
- Induced Draft fans – due to the more stringent equipment compliance requirements (e.g. ATEX) for hydrogen, the induced draft fans would need to be replaced.
- Electrical Control and Instrumentation – Depending on the DSEAR zoning changes, electrical and control equipment may need to be replaced to meet the ATEX requirements.

The capital cost of modifications are site specific due to the various types and scales of kilns used in industry. **Figure 8** shows estimated capital costs for modifications to equipment in various industrial sectors to allow for the switch from natural gas to hydrogen (19). These costs include the equipment and material costs as well as associated costs such as labour, engineering design and commissioning.

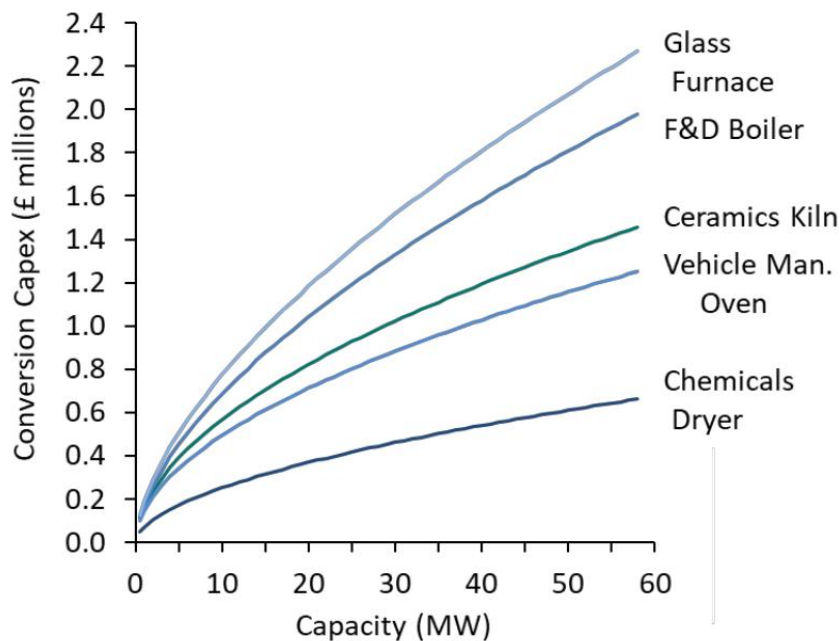

Figure 8. Cost curves for a sample of equipment types in specific industrial sectors (19)

The Hy4Heat study estimated the distribution of equipment sizes in each industry and showed that the majority of the kilns in the ceramic industry are below 10 MW in capacity. They estimated that there were approximately 160 kilns that had capacities >1 MW, with a total capacity of 880 MW. This gives an average capacity for these kilns of around 5 MW. Using the cost curve from **Figure 8**, the conversion CAPEX for this average sized commercial kiln would be approximately £390,000.

3.6 Comparison to alternative ceramic kiln decarbonisation options

WSP | Parsons Brinckerhoff and DNV GL facilitated and developed a Decarbonisation and Energy Efficiency Roadmap for the Ceramic Sector (2015) in collaboration with industry, academia and government (20). They identified a number of options to contribute to decarbonisation of the ceramics industry. These included:

- **Adopt lowest carbon process (Best Available Technology kilns)** - Utilising kiln designs with improved heat recovery and fuel combustion to replace existing units will reduce energy consumption.
- **Onsite gasification of biomass** - Substituting a large part of the natural gas consumed by a large scale kiln by a syngas generated by gasification of biomass or waste. Complete replacement of the natural gas was not considered to be viable as it would require syngas production by a more complex and less efficient gasifier using oxygen instead of air.
- **Large scale electric kilns using low carbon grid electricity** - Replacing fuel burned in kilns by electrical heating. While electrically heated kilns are used for a limited number of firing processes in the sector, there is no experience of large scale continuous kilns being electrically heated. The use of electrical heating would require a substantially different kiln design to use the different heat source and would only be implemented as a replacement for a kiln at the end of its life.
- **Carbon capture from exhaust gases** - applying carbon capture technology to the flue gases from the large ceramic kilns to capture a high percentage of fuel and process carbon emissions. The equipment could be added to new and existing kilns and would have no impact on the production process. The site would need to have space for the necessary equipment for capture and export of the CO₂.

Table 13 shows the reduction in CO₂ emissions and the associated CAPEX requirements for the four options. It is unclear from the roadmap what the scale of the site is in each case. If one assumes that the 3 MW_{LHV,H2} kiln case developed for this Feasibility study is representative of a site, then the full PROGREEN H2 process will not be a viable alternative to these options (see Sections 3.2.3 and 3.3.1 for more details). Although the potential reduction in CO₂ would be higher than these options if renewable sources of electricity are used, the CAPEX requirements are more than 500 times greater.

Table 13. Comparison of decarbonisation options in terms of CO₂ emission reduction and CAPEX requirements (21)

| Technology | CO ₂ emissions reduction | CAPEX per site |
|---|-------------------------------------|----------------|
| | % | £ million |
| Adopt lowest carbon process (Best Available Technology kilns) | 11-30 | 1-20 |
| Onsite gasification of biomass | 29 | 15 |
| Large scale electric kilns using low carbon grid electricity | 80 | 20 |
| Carbon capture from exhaust gases | 50 | 10 |

If one were to consider the alternative PROGREEN technology option where only ammonia is fed to the system and cracked to form hydrogen on site, it becomes much more comparable. If renewable energy is used in the production of the ammonia and on site for the cracking process, the reduction in CO₂ emissions is close to 100%². The capital requirement for the ceramics manufacturer would be £19 million, which is comparable to the options shown in **Table 13**. This does not include any capital requirements for the ammonia producer.

3.7 Technical and regulatory feasibility

The PROGREEN process aims to combine several technology steps into a consolidated process to allow for the combustion of hydrogen in the ceramic industry. The challenge is that a number of these steps are still in the early stage of technology development and still require significant work to allow for a feasible overall process.

The key stages include:

- Non-thermal plasma desalination (TRL level 3)
- Non-thermal plasma ammonia synthesis (TRL level 3)
- Ammonia cracking via a catalytic membrane reactor (TRL level 3)
- Hydrogen-fed ceramic kiln (TRL level 4)

A number of key challenges identified in this study are summarised below:

² There will still be some CO₂ emissions associated with the transport of the ammonia.

- The non-thermal plasma desalination step has only been proven at laboratory scale in glassware (not as part of this study). Further scale up work would need to be performed to allow for vessel design. This would need to involve pilot-scale testing to determine the impact of larger scale vessels as well as plasma torch numbers and placement as well as power requirements.
- The very low conversion of the nitrogen feed to the non-thermal plasma ammonia production step should be the focus of any further development. This dictates the nitrogen flow rates through the reactor and currently results in very high flows in a recycle loop, requiring large vessels and very high operating costs.
- The ammonia cracking reactor is a catalytic membrane reactor that requires a sweep gas system as well as enough membrane area to allow for the permeation of the hydrogen product through the membrane. Scale up of this type of membrane is not trivial and will require further development work. Pilot scale testing will be required to determine practical membrane tube dimensions, both from a manufacturing point of view, as well as reactor performance. The reactor design has a number of limitations that need to be considered, including the membrane area for hydrogen permeation and the tube inner diameter for catalyst volume and pressure drop.
- The catalysts proposed for both the ammonia production as well as the ammonia cracking step are ruthenium based. Ruthenium is a very rare, expensive metal that would result in a high cost and low availability of the catalyst. Further work would need to be done to identify alternative catalysts that have a lower cost and are more readily available. This would involve further catalyst screening activities (to build on the work done at the University of Hull in this study), along with catalyst performance testing of any promising catalysts at laboratory-scale.

Taking all of the above points into account, as well as the high capital and operating costs, the PROGREEN route to produce hydrogen is not feasible at this stage. A number of the other alternative hydrogen production technologies would be more suitable for the ceramic industry to consider.

Should on-site hydrogen generation be preferred by a particular ceramics manufacturer, it is possible to purchase containerised electrolysis units that could be installed on site near the kiln and feed the hydrogen directly into the burner system. The only requirements would be a source of water and electricity, and depending on the type of electrolysis technology, an electrolyte feedstock. This would eliminate the hydrogen transportation costs associated with a more centralised hydrogen production technology.

Should more industries consider a centralised hydrogen production model, the other low carbon hydrogen production options (e.g. methane reforming with CCUS or biomass gasification) should be considered. This would require a developed hydrogen transportation and storage system.

In terms of regulatory feasibility, the key considerations are air quality as well as safety. The gov.uk website provides guidance on air quality regulations, particularly the following air pollutants:

- fine particulate matter (PM_{2.5}),
- ammonia (NH₃),
- nitrogen oxides (NO_x),
- sulphur dioxide (SO₂), and
- non-methane volatile organic compounds (NMVOCs)

The potential air pollutants from the PROGREEN process would include fugitive emissions of ammonia and hydrogen, nitrous oxide (N₂O) and nitrogen oxides (NO_x) during combustion of hydrogen at high temperatures in the kiln.

At this stage of development, fugitive emissions have not been quantified, but are likely to occur from leaks in equipment and piping as well as purging steps during start-up and shutdown. These would need to be minimised by careful consideration during future detailed design. Some key measures would include using welded piping where possible, as well as ensuring purging and venting steps are kept to a minimum.

The nitrous oxide by-product that is produced in the non-thermal plasma ammonia production goes through a decomposition step in a catalytic reactor, producing nitrogen and oxygen, which is then vented to atmosphere. There are no emissions limits for nitrous oxide, however, since it is a significant greenhouse gas, the emissions will be limited. Recent studies have shown that it is possible to achieve 100% conversion of the nitrous oxide to nitrogen and oxygen at temperatures below 400 °C.

As shown in Section 3.1, the increase in nitrogen oxides (NO_x) content in the flue gas is significant (approximately three times higher). This is as a result of the higher flame speed and associated local flame temperature when combusting hydrogen. There are technologies available at commercial scale to remove these nitrogen oxides from the combustion gases, including:

- Selective Catalytic Reduction (SCR) which involves the introduction of ammonia or urea into the flue gas zone and passing it over a catalytic bed. The NO_x present will react with oxygen in the presence of a catalyst to form nitrogen and water.
- Selective Non-Catalytic Reduction (SNCR) also involves the introduction of ammonia or urea into the flue gas zone, but without a catalyst present.

In terms of safety, the primary regulations that will govern the handling of hydrogen and the associated infrastructure are Dangerous Substances and Explosive Atmospheres Regulations

(DSEAR) (22), Control of Major Accident Hazards (COMAH) (23) and Pressure Equipment (Safety) Regulations (PER) (24). Hydrogen is a named dangerous substance under COMAH regulations. The threshold quantities are 5 tonnes (lower tier) and 50 tonnes (upper tier) and should be noted in the future planning process. For the PROGREEN demonstration unit, the quantities of hydrogen stored, will be well below these threshold values.

The European Industrial Gases Association (EIGA) has published a guideline document on the operating risks and guidelines for the safe design and operations of various hydrogen and syngas production facilities (25). They refer to a number of EU directives that are applicable to the safe design of these types of facilities, including:

- ATEX 137A directive 99/92/EC– defining the requirements for the protection of workers potentially at risk from explosive atmospheres (26)
- ATEX 114 directive 2014/34/EU – regarding the equipment and protective equipment used in potentially explosive atmospheres (27)
- Pressure Equipment Directive – 97/23/EC & Pressure vessel directive: 2014/68/EU – regarding the design and manufacture of pressurised equipment (28).

The design of the PROGREEN process and equipment would need to conform to the above directives and relevant UK legislation.

3.8 Questionnaire Responses

Lucideon reached out to 34 high gas consumption users in the ceramics sector via a questionnaire to understand their concerns regarding switching to hydrogen as a fuel (see Appendix 4 for more details).

A summary of the responses to the questionnaire are provided in **Table 14**.

Table 14. Summary of questionnaire responses

| Question | Response |
|--|--|
| Do you fire in a reducing atmosphere? | 31% fire in a reducing atmosphere. |
| What type of ware would you be interested in firing? | Biscuit, tableware, sanitaryware, glassware, roof tiles and bricks, clay biscuit and glost, porcelain bottles/flagons, earthenware and glost. Facing bricks/blue bricks and water filters. |

| Question | Response |
|---|---|
| What tests would you require on your ware after firing? | Water absorption, shrinkage, colour/translucency, spectrophotometer and chemical durability tests, porosity, vitrification, strength and colour for biscuit, appearance, metal release, detergent resistance. |
| What parameters / properties do you consider critical to your product? | Thermal shock resistance, whiteness, fired appearance, chemical durability, crushing strength, flexural strength. Maintain current levels of physical performance, no change to fired size or finished appearance. |
| Approximately what are your current kiln volume requirements? | 1 m ³ – 4 million m ³ |
| What potential combustion impurities would you consider harmful to your product? | Excessive carbonaceous impurity, water vapour (excessive moisture, water condensation), sulphur. * Reducing atmosphere will be harmful to tin oxide (as it can return to metallic state). |
| Do you fire ware which is sensitive to colour change and is this likely to affect the saleability of your product? | 61% of participating manufacturers stated that colour is critical. |
| Does your product contain any additives that you would consider likely to cause issues in a high hydrogen atmosphere? | Manganese and Tin Oxide. Other companies were not certain if there is an issue with their additive and a high hydrogen atmosphere. |
| Do you currently use electric fired kilns and if so, what is your estimated current site MW electric usage for firing per year? | Only 23% of participating manufacturers use electric firings. Usage ranges from 5000 – 10700 MW/yr. |
| What is the estimated current site MW gas usage for firing per year? | 8 – 170,000 MW/yr |
| A hot zone of 1 x 0.8 x 0.6M is likely for the experimental kiln. What volume of ware would you expect to provide for trials? | All participating manufacturers agreed that this volume was acceptable for trials. |
| What are your current limits on flue gas emissions? | For most this is not applicable and where applicable limit is set for HF, SO _x , solid particulates, visible smoke and CO. |
| What concerns do you have in potentially operating a 100% hydrogen kiln? H&S, product conformity, emissions, hydrogen supply, existing kiln modifications, kiln modifications, gas storage etc. | <ul style="list-style-type: none"> • Hydrogen supply pressures, storage, and transportation. • Product conformity and consistency throughout the kiln. • Modifications to the kiln and firing cycle time. • Burner compatibility and issues with engineering design (modification costs). • Suitability of kiln fabric and refractory material to the Hydrogen fuel. • Moisture. • Increase NO_x • Safety of gas supply, integrity of associated pipework, effectiveness of control equipment, gas storage. |

Lucideon held further in-depth end user discussions with a tableware manufacturer and a sanitaryware manufacturer (see Appendix 4 for more details). The feedback from these discussions can be summarised in the following comments and concerns regarding the implementation of the PROGREEN process:

- Insufficient plant size to accommodate a large ammonia cracking plant and other infrastructure.
- Concerned about health, safety and planning requirements
- Concerned about the need to replace pipework due to the potential for hydrogen embrittlement of certain types of metal.
- Concerned about retrofitting furnaces with new burners (cost and whether it is even possible).
- Would like to see what effect hydrogen firing has on furnace infrastructure such as kiln cars, burners, bearings etc.
- Concern was also raised about moisture effect on the products and kiln furniture
- Would the cost of hydrogen production and ammonia supply be prohibitive?

Most of these concerns are not limited to the PROGREEN process, but for the general shift from natural gas to hydrogen as a fuel for the ceramic industry.

4 Stream 2B delivery plan

According to DESNZ (previously BEIS) (29), the Stream 2B competition of the Industrial Hydrogen Accelerator programme is looking to fund end-to-end industrial demonstrator/FEED projects which have already completed some scoping and feasibility work (including through Stream 2A).

The purpose of the feasibility study that was undertaken for Stream 2A was to determine if the combination of the various technology steps to produce hydrogen from nitrogen and sea water was feasible. Based on the results presented in this report, the outcome from the study is that significant elements of the technology are not ready to take forward into a FEED study or build a demonstration plant. Further work is needed at a fundamental level, especially for the non-thermal plasma ammonia production step, to enable higher a higher conversion of nitrogen. As discussed in Section 3.6, the key focus would be to identify and develop the catalyst at laboratory-scale for the ammonia production step to achieve nitrogen conversion values that allow for an economically viable process.

As a result of this, there are no plans to continue into the Stream 2B competition.

5 Value and benefits

5.1 Social value

As discussed in Section 3.4.2, the emissions intensity of the proposed PROGREEN process is 387.4 kgCO₂e/kg_{LHV} H₂ if grid electricity is used and only 0.0011 kgCO₂e/kg_{LHV} H₂ if wind or solar derived electricity is used. These translate to 107,618 gCO₂e/MJ_{LHV} H₂ and 0.3 gCO₂e/MJ_{LHV} H₂ respectively. This would mean that only if wind or solar derived electricity is used, would the technology meet the Low Carbon Hydrogen Standard of less than 20 gCO₂e/MJ_{LHV} H₂.

The alternative PROGREEN case shows a larger reduction in the GHG emissions (see Section 3.3.4 and 3.4.2), but the source of the ammonia feedstock would need to be from a renewable process. If this can be achieved, and the PROGREEN ammonia cracking section can operate using renewable electricity, the technology would meet the LCOH of less than 20 gCO₂e/MJ_{LHV} H₂.

Using the information above, and the fact that the current combustion of natural gas emits 0.2 kgCO₂e/kg_{LHV}, the PROGREEN technology would only reduce the GHG emissions if renewable electricity is used (i.e., from wind or solar). For the alternative case, the ammonia would also need to be produced using renewable energy sources and not from a fossil fuel source.

Although the overall PROGREEN process is not viable, the knowledge gained in conducting the feasibility study will allow UK industrial sectors to rather focus on other more promising technologies to produce hydrogen to use as a fuel.

5.2 Benefits derived through contract

Table 15 gives a summary of the benefits derived through the contract. The performance related to each benefit has been discussed in other sections of the report.

Table 15. Summary table of benefits derived through the contract

| Benefit | Measure | Unit | Performance | |
|--|---|--|-------------|------------|
| | | | SZA start | SZA finish |
| Demonstrate potential for commercial viability of end-to-end hydrogen industrial fuel switching systems | Feasibility study of the end-to-end system conducted | Yes/No | No | Yes |
| | Successfully evidenced technical and commercial potential for system and plans for implementation | Yes/No | No | No |
| | Technology Readiness Level progression | TRL level | 3-4 | 3-4 |
| Provide evidence and knowledge to support future hydrogen and industrial decarbonisation policy | Successful completion and publication of project reports providing evidence on costs and performance of system and technologies | Yes/No | No | Yes |
| Increased awareness, understanding and confidence in end-to-end hydrogen fuel switching solutions for industry to facilitate future deployment | Amount of domestic interest in the technology | Questionnaire response % | 0 | 41 |
| | Number of events for the purpose of sharing/exchanging knowledge (co-)produced as a result of the project | Number | 0 | 1 |
| | Number of other knowledge exchange or dissemination products or activities generated as a result of this project e.g., digital, and printed media (leaflets, videos, etc.), and social networks | Number | 0 | 4 |
| | Amount of media/research coverage, including announcement of new projects/partnerships | Number | 0 | 1 |
| | Number of project reports/documents published | Number | 0 | 1 |
| Potential reduction in carbon emissions of a specific industrial process | Carbon intensity of process before and after innovation is applied | kgCO ₂ e/kWh _{LHV} | 0.2 | 0.011 |
| | Potential volume of CO ₂ saved (kT CO ₂ e/yr) for this particular site | kT CO ₂ e/yr (3MW site) | 0 | 4.85 |
| | Potential volume of CO ₂ saved (kT CO ₂ e/yr) if this innovation was deployed across all UK sites that use this process | kT CO ₂ e/yr | 0 | 949 |

5.3 Knowledge dissemination and engagement

Sharing of information and results of the study as well as engaging with industry are key activities related to this project. The following approaches have been used to achieve this goal:

- Attendance of steering groups of the Humber Industrial Cluster Plan (HICP) and EPSRC hub for Hydrogen Integration
- Reaching out to 34 high gas consumption users in the ceramics sector via a questionnaire to understand their concerns regarding switching to hydrogen as a fuel (see Section 3.8 and Appendix 4 for more details)
- In-depth end user discussion with a tableware manufacturer and a sanitaryware manufacturer (see Section 3.8 and Appendix 4 for more details)
- A webinar event to discuss the project as a whole
- Project website
- Social media accounts, including LinkedIn and Twitter

5.4 Enabling fuel switching

To achieve its carbon reduction strategy, the UK ceramics industry will adopt a hybrid approach; with each company looking at combinations of electrification, blended hydrogen/natural gas as well as the use of 100% hydrogen. There are a number of barriers to the potential adoption of 100% hydrogen as a combustion gas in the industry; viable hydrogen supply options, manufacturers concerns around the costs and practicalities of switching existing kiln assets to combust 100% hydrogen and finally, product specific materials questions relating to the firing environment of 100% hydrogen.

This feasibility project is aimed at developing a demonstrator to implement novel methods for the generation of hydrogen and establishing a research kiln test platform. This will support the ceramics industry with the ability to answer questions regarding product and material properties developed during a 100% hydrogen firing. It will also upskill UK kiln builders in the requirements of design and conversion of a small kiln from natural gas to 100% hydrogen.

5.5 Assessment of future potential

The results of this feasibility study have shown that the system is not currently viable. Significant improvements in the nitrogen conversion in the non-thermal plasma ammonia production step should be the focus of any further development with this technology. This would need to be

evaluated and proven at laboratory scale before further consideration of the overall system feasibility can be re-evaluated.

The alternative PROGREEN case that eliminates the non-thermal plasma step and just utilises ammonia as a feedstock shows more promise and similar systems have been shown to be viable alternatives (15). It is important to ensure that the ammonia is generated via a process that utilises renewable electricity sources, as this will allow for the overall GHG emissions to remain low.

In the meantime, the evaluation and testing of ceramic kiln concepts to allow for the combustion of hydrogen instead of natural gas should continue. This is one of the key enablers in terms of the fuel switching goal and will need to be successful, regardless of the source of the hydrogen.

6 Conclusions and recommendations

A feasibility study into an end-to-end system for generation and use of green hydrogen for fuel switching in ceramics manufacturing has been performed. The proposed process consists of several novel technologies that are still in early stages of development. These processes have been combined into a complete system based on the information available in open literature.

The capital and operating expenses associated with this system have been estimated and used to develop a techno-economic analysis assessment. The outcomes of this assessment show that the process in its current form is not economically viable. The levelised cost of hydrogen produced in the process is more than 2000 times higher than any of the alternative low carbon hydrogen production technologies.

The main reason for this is the very low conversion of nitrogen to ammonia (approximately 0.03%) in the non-thermal plasma ammonia production step. This results in a very large recycle of unreacted nitrogen gas and requires significant capital and operating expenses to accommodate this recycle. The catalysts developed at the University of Hull and tested at Newcastle University did not show a large enough improvement to change the outcome of the study.

As a result of this, the overall system is not at a stage where it can proceed to a FEED study or demonstration scale plant. Further fundamental research is necessary to evaluate whether the nitrogen conversion to ammonia can be improved to a level where the entire process can be economically viable. Key to this will be identifying, developing and testing alternative catalysts that can improve the nitrogen conversion and lower the electrical power requirements.

An alternative case was considered that takes in ammonia as a feedstock and only makes use of the hydrogen production and combustion section of the proposed process. This eliminates the inefficient non-thermal plasma steps in the production of ammonia and as a result provides a more viable technology option. This would build on the operating model of having a central ammonia production facility, but then transporting the ammonia to site to produce the hydrogen for use. The key consideration for this case will be the source of the ammonia to ensure that the emissions associated with its production are low and the source of energy is renewable.

While this alternative case improves the economic viability of the process, it still results in a levelised cost of hydrogen of more than two times any of the alternative low carbon hydrogen technologies.

Lucideon and Therser constructed a burner test stand to enable the testing of firing a kiln with 100% hydrogen. Successful firing using 100% hydrogen resulted in approximately 94% less CO₂ content in the flue gas, while there was an increase of approximately 2.5 times more NO_x content. Using the results of these tests, designs for pilot-scale kilns for temperatures of 1300 °C and 1750°C were developed.

Based on these results the use of hydrogen in the ceramics industry as a fuel for kiln burners is feasible. Various modifications would be required to existing kilns to allow for the combustion of hydrogen by the burners. These modifications will be specific to each site and type of kiln and the costs associated with these modifications will vary accordingly.

The ceramics industry still have a number of concerns around the health, safety and planning requirements associated with the switch to the hydrogen fuel. Other concerns include the cost of the modifications as well as the impact that the hydrogen combustion and associated effect that an increase in moisture will have on the final ceramic product. The pilot-scale kilns developed by Lucideon and Therser will be used in future to test fire a variety of ceramic products to improve the understanding of the impact of firing these products using 100% hydrogen.

7 References

1. **Department of Business, Energy and Industrial Strategy.** Industrial Hydrogen Accelerator Programme (closed). [Online] 21 July 2022. [Cited: 05 December 2022.] <https://www.gov.uk/government/publications/industrial-hydrogen-accelerator-programme>.
2. **Department of Business, Energy & Industrial Strategy and British Ceramic Confederation.** *Ceramic Sector - Joint Industry - Government - Industrial Decarbonisation and Energy Efficiency Roadmap*. October 2017. https://assets.publishing.service.gov.uk/government/uploads/system/uploads/attachment_data/file/651229/ceramics-decarbonisation-action-plan.pdf.
3. **Department of Business, Energy & Industrial Strategy.** *UK Hydrogen Strategy*. London : Crown, 2021. CP 475. https://assets.publishing.service.gov.uk/government/uploads/system/uploads/attachment_data/file/1011283/UK-Hydrogen-Strategy_web.pdf.
4. *Atmospheric-pressure plasma seawater desalination: Clean energy, agriculture, and resource recovery nexus for a blue planet.* **Ekanayake, U.G.M., et al.** 2020, *Sustainable Materials and Technologies*, p. <https://doi.org/10.1016/j.susmat.2020.e00181>.
5. *Sustainable Ammonia Synthesis from Nitrogen and Water by One-Step Plasma Catalysis.* **Zhang, Tianqi, et al.** <https://doi.org/10.1002/eem2.12344>, 2022, *Energy & Environmental Materials*, Vol. 0, pp. 1-9.
6. *A catalytic composite membrane reactor system for hydrogen production from ammonia using steam as a sweep gas.* **Park, Yongha, et al.** <https://doi.org/10.1016/j.memsci.2020.118483>, 2020, *Journal of Membrane Science*, Vol. 614.
7. **Environment Agency and Department for Environment, Food & Rural Affairs.** Air emissions risk assessment for your environmental permit . [Online] Crown, 5 July 2022. [Cited: 07 January 2023.] <https://www.gov.uk/guidance/air-emissions-risk-assessment-for-your-environmental-permit>.
8. **Liu, Huazhang.** *Ammonia Synthesis Catalysts: Innovation and Practice*. Singapore : World Scientific Publishing Co., 2013. ISBN: 9789814355780.

9. **Gorbanev, Yury, et al.** Nitrogen Fixation with Water Vapor by Nonequilibrium Plasma: toward Sustainable Ammonia Production. *ACS Sustainable Chemistry & Engineering*. 2020, Vol. 8, 7, pp. 2996-3004.

10. **Department of Business, Energy & Industrial Strategy.** *Greenhouse gas reporting: conversion factors 2021*. London : Crown, 2021.
<https://www.gov.uk/government/publications/greenhouse-gas-reporting-conversion-factors-2021>.

11. **Loh, H.P., Lyons, J. and White, C.W.** *Process Equipment Cost Estimation Final Report*. Morgantown : National Energy Technology Lab, 2002. DOE/NETL-2002/1169.
<https://www.osti.gov/servlets/purl/797810>.

12. **Garrett, D.E.** *Chemical Engineering Economics*. Dordrecht : Springer Netherlands, 2012. ISBN 9789401165440.

13. **Sinnott, R.K.** *Chemical Engineering Design*. Netherlands : Elsevier Science, 2005. ISBN: 9780080492551.

14. **Department of Business, Energy and Industrial Strategy.** *Hydrogen Production Costs 2021*. London : Crown, 2021. <https://www.gov.uk/government/publications/hydrogen-production-costs-2021>.

15. **Ecuity.** *Ammonia to Green Hydrogen Project - Feasibility Study*. Birmingham : Ecuity.com, 2020. HS420.
https://assets.publishing.service.gov.uk/government/uploads/system/uploads/attachment_data/file/880826/HS420_-_Ecuity_-_Ammonia_to_Green_Hydrogen.pdf.

16. **International Fertilizer Industry Association.** *Energy Efficiency and CO2 Emissions in Ammonia Production*. Paris : IFA, 2009.
https://www.fertilizer.org/images/Library_Downloads/2009_IFA_energy_efficiency.pdf.

17. *Ammonia as a Renewable Energy Transportation Media*. **Giddey, S., et al.** 11, *ACS Sustainable Chemistry & Engineering* : ACS Publications, 2017, Vol. 5. DOI: 10.1021/acssuschemeng.7b02219.

18. **IRENA and AEA.** *Innovation Outlook: Renewable Ammonia*. Abu Dhabi : IRENA, 2022. ISBN: 978-92-9260-423-3. https://www.irena.org/-/media/Files/IRENA/Agency/Publication/2022/May/IRENA_Innovation_Outlook_Ammonia_2022.pdf.

19. **Durusut, Emrah, et al.** *Hy4Heat WP6: Conversion of Industrial Heating Equipment to Hydrogen*. Cambridge : Element Energy Limited, 2019. <https://www.hy4heat.info/s/WP6-Industrial-Heating-Equipment.pdf>.
20. **WSP | Parsons Brinckerhoff and DNV GL.** *Industrial Decarbonisation & Energy Efficiency Roadmaps to 2050 - Ceramic Sector*. 2015. https://assets.publishing.service.gov.uk/government/uploads/system/uploads/attachment_data/file/416676/Ceramic_Report.pdf.
21. **WSP Parsons Brinckerhoff and DNV GL.** *Industrial Decarbonisation & Energy Efficiency Roadmaps to 2050 - Ceramic Sector Appendices*. 2015. https://assets.publishing.service.gov.uk/government/uploads/system/uploads/attachment_data/file/416194/Ceramic_Appendices.pdf.
22. **UK Government.** *The Dangerous Substances and Explosive Atmospheres Regulations*. 2002. 2776.
23. —. *Control of Major Accident Hazards Regulations*. 2015. 483.
24. —. *Pressure Equipment (Safety) Regulations*. 2016. 1105.
25. **EIGA.** *Safety of Hydrogen, HYCO Production and Carbon Capture*. Brussels : EIGA, 2020. Doc 242/22. <https://www.eiga.eu/uploads/documents/DOC242.pdf>.
26. **European Parliament, Council of the European Union.** *Directive on minimum requirements for improving the safety and health protection of workers potentially at risk from explosive atmospheres*. 1999. 1999/92/EC.
27. —. *Directive on the harmonisation of the laws of the Member States relating to equipment and protective systems intended for use in potentially explosive atmosphere*. 2014. 2014/34/EU.
28. —. *Directive on the harmonisation of the laws of the Member States relating to the making available on the market of pressure equipment*. 2014. 2014/68/EU.
29. **Department of Business, Energy & Industrial Strategy.** *Industrial Hydrogen Accelerator - Stream 2B Competition Guidance Notes*. London : Crown, 2022. GRANT COMPETITION - PRJ_387. https://assets.publishing.service.gov.uk/government/uploads/system/uploads/attachment_data/file/1124754/iha-competition-guidance-stream-2b.pdf.

30. *Plasma Catalyst-Integrated System for Ammonia Production from H₂O and N₂ at Atmospheric Pressure*. **Muzammil, Iqbal, et al.** <https://doi.org/10.1021/acscenergylett.1c01497>, 2021, ACS Energy Letters, Vol. 6, pp. 3004-3010.

31. **Jenkins, S., et al.** *Management of Brine Discharges to Coastal Waters Recommendations of a Science Advisory Panel*. Costa Mesa, CA : Southern California Coastal Water Research Project, 2012. Technical Report 694.
https://www.waterboards.ca.gov/water_issues/programs/ocean/desalination/docs/dpr051812.pdf.

32. **Environmental Agency and Department for Environment, Food & Rural Affairs.** Surface water pollution risk assessment for your environmental permit. *Gov.uk*. [Online] Crown, 25 February 2022. [Cited: 07 February 2023.] <https://www.gov.uk/guidance/surface-water-pollution-risk-assessment-for-your-environmental-permit>.

Appendices

| No. | Title | Organisation |
|-----|---|-------------------------|
| 1 | A Technical Report on WP1-Deliverables 1.2 and 1.3: Synthesis and characterization of transition metal supported Ammonia Synthesis Catalysts (Confidential sections removed from publicly available version of this report) | University of Hull |
| 2 | Technical Report on Work Package 1a and 2: WP1a: Experimental non-thermal plasma ammonia synthesis; WP2: First principle modelling and analysis of catalytic membrane reactor for ammonia cracking to produce hydrogen (CONFIDENTIAL) | Newcastle University |
| 3 | Short report on Design of Non-thermal plasma (NTP) process for water desalination and sizing, modelling and validation of NTP reactor for ammonia production | University of Sheffield |
| 4 | Ceramic Sector Consultation and Test Plan for Firing Ceramic Products Using Hydrogen as a Fuel (CONFIDENTIAL – Executive Summary included in lieu of report) | Lucideon |
| 5 | Therser Hydrogen Test Kiln Report | Therser UK |
| 6 | Draft design of 1,300 °C multipurpose ceramic test kiln | Therser UK |
| 7 | Draft design of modify existing 20% hydrogen kiln (1,750 °C) | Therser UK |
| 8 | Process Basis of Design for PROGREEN H2 – Feasibility Study (CONFIDENTIAL) | CPI |
| 9 | Process Flow Diagrams for PROGREEN process (CONFIDENTIAL) | CPI |
| 10 | PROGREEN Mass & Energy Balance (CONFIDENTIAL) | CPI |
| 11 | Equipment Sizing & Utility Requirements (CONFIDENTIAL) | CPI |
| 12 | Process CAPEX Estimation (CONFIDENTIAL) | CPI |
| 13 | Techno-Economic Analysis (CONFIDENTIAL) | CPI |
| 14 | Preliminary Major Equipment List (CONFIDENTIAL) | CPI |
| 15 | PROGREEN Process Efficiency Comparison (CONFIDENTIAL) | CPI |
| 16 | PROGREEN Emissions reduction and comparison (CONFIDENTIAL) | CPI |
| 17 | PROGREEN Levelised Cost of Hydrogen (CONFIDENTIAL) | CPI |
| 18 | Literature Review into the Use of Hydrogen as an Alternative Fuel for Ceramic Manufacturing Processes | Lucideon |

Appendices not included in the public report can be requested from CPI at <https://www.uk-cpi.com/contact>.

| No. | Summary (see Appendix for further detail) |
|-----|---|
| 1 | This report provides a draft summary of the work carried out on the Synthesis and characterisation of transition metal supported Ammonia Synthesis Catalysts under WP1. The catalyst synthesized have been forward to partner UNC to test for the production of green ammonia using NTP catalysis approach. |
| 2 | <p>WP1a: A technical report discussing ammonia production through barium titanate, and through Catalyst. The results through barium titanate showed the ammonia formulation to be slow, with the experience taking 130 minutes to achieve 6.64 pH and the ammonia production being 25 ppm. Through Catalyst, a pH of 6.92 was reached in 8 minutes with the ammonia production being 689 ppm. The report also discusses the effect of power on the catalyst performance.</p> <p>WP2: The objectives of the project are to develop models of packed-bed membrane reactor for catalytic ammonia decomposition into hydrogen. (a) First, a generalised reactor was developed to create an adequate understanding of the catalytic reactor zone and membrane hydrogen flux using chemical reaction engineering principles. (b) Next, a similar reactor will be developed using the experimental kinetics of reaction and membrane parameters for Lithium amide-imide catalytic ammonia decomposition.</p> |
| 3 | Results show that an NTP reactor of diameter of 0.101 m and a length of 0.3 m will be required for the ammonia production process. The NTP reactor size is dependent on the gas volumetric flow rate. A ready-state lump sum model of the reactor was developed and validated with experimental data. |
| 4 | A questionnaire was sent to 34 UK manufacturers in the ceramics sector regarding using hydrogen for firing ceramics to potentially reduce CO ₂ emissions. These responses were used to produce a test plan considering properties such as strength, water absorption, shrinkage, and colour. The plan will investigate the effect of firing with H ₂ on critical ceramic properties and explore possible limitations. |
| 5 | <p>Therser have built a test kiln with the ability to test combustion of 100% hydrogen and percentage mixes of natural gas and hydrogen. The results of the 100% hydrogen test showed that when comparing firing results to natural gas, the gas consumption of hydrogen was nearly 3 times greater than gas. Furthermore, the NO_x, NO and SO₂ are far greater on the 100% hydrogen, with the CO₂ being greater on natural gas firing.</p> <p>The required flow rate to run at full power rating was 22 m³/h, however, due to pressure inhibition of compressed gas, only 15m³/h could be achieved.</p> |
| 6 | <p>A draft design was developed regarding the 1,300 °C multipurpose ceramic test kiln. For the process required of this kiln to be achieved using 100% hydrogen gas, it is reasonable to assume the volume of hydrogen will be approximately 250 m³ - 310 m³ and produce 187.7 kg - 23 kg of water vapour and have a flue humidity of nearly 30% (assuming combustion air is dry).</p> <p>The required volumetric flow rate of hydrogen for 1300 °C test kiln is 90 Nm³/h. Using a compressed bottle system is not practical as it requires a large number of banks to achieve both flow and total consumption of hydrogen during firing cycle.</p> |
| 7 | A draft design was developed regarding the modification of existing 20% hydrogen kiln (1750 °C). For the process required of this kiln to be achieved using 100% hydrogen gas, it is reasonable to assume the volume of hydrogen will be approximately 800m ³ - 978.2 m ³ and produce 600 kg - 730 kg of water vapour and have a flue humidity of nearly 30% (assuming combustion air is dry). |

| | |
|----|--|
| | The required volumetric flow rate of hydrogen for 1750 °C test kiln is 170 Nm ³ /h. Using a compressed bottle system is not practical as it requires a large number of banks to achieve both flow and total consumption of hydrogen during firing cycle. |
| 8 | A feasibility study was carried out regarding the process basis of design for PROGREEN H2. The purpose of this study was to develop the concept of the Industrial Hydrogen Accelerator and improve the understanding of the technologies involved and the performance and costs of the system. |
| 9 | Process flow diagrams of PROGEEN process. |
| 10 | As part of an FEL-2 design study, the following calculation outlines a high level Mass and Energy Balance (M&E) conducted by CPI to assess the potential material properties and flow conditions associated with the PROGREEN hydrogen production and ceramic firing process. |
| 11 | Conducted as part of the FEL-2 PROGREEN deliverable, this appendix outlines calculations regarding the estimated operational expenditure (OPEX) for the PROGREEN hydrogen production and firing process. The associated unit sizing that may be employed within the 3MW hydrogen demonstration facility was shown alongside this. |
| 12 | Conducted as part of the FEL-2 PROGREEN Feasibility Study work package, the current capital expenditure (CAPEX) estimate was conducted, considering major unit costs only. The total equipment cost was £1,499,649,693. |
| 13 | Technoeconomic Analysis (TEA) considering the PROGREEN hydrogen production process and associated ceramic firing. This is a high-level assessment and does not consider any standby units, filter screens or pressure regulating valves. |
| 14 | Preliminary Major Equipment list specified in line with the PDF documents and Mass and Energy balance document in line with the agreed upon scope of the PROGREEN H2 project. *See appendix for complete list |
| 15 | One of the requirements for the BEIS IHA Stream 2A programme is to evaluate the process efficiency of the new technology, as well as to compare the proposed technology to alternative technology options. This calculation addresses these requirements for the PROGREEN H2 project as follows: - The process efficiency of the proposed technology is estimated based on the electricity requirement for the process. Since there is no fuel source in the process, no thermal conversion efficiency is noted. - The process efficiencies of the alternative technologies (Electrolysis, CCUS enabled methane reforming and CCUS enabled biomass gasification) were obtained from the BEIS Hydrogen Production Cost report for 2021 |
| 16 | One of the requirements for the BEIS IHA Stream 2A programme is to determine the emissions reduction potential of the new technology, as well as to compare the proposed technology to alternative technology options. This calculation addresses these requirements for the PROGREEN H2 project as follows: - The equivalent CO ₂ emissions from combusting natural gas is used as the base case, since more than 80% of the ceramic kilns are fired by natural gas - The emissions from the proposed PROGREEN H2 process have been estimated using the BEIS Hydrogen Emissions Calculator. Two cases have been included, where (1) wind/solar is used as the source of electricity and (2) grid electricity is used. |

| | |
|----|---|
| | <p>- The emissions from the alternative technologies (Electrolysis, CCUS enabled methane reforming and CCUS enabled biomass gasification) were estimated based on information from the BEIS Hydrogen Production Cost report for 2021 and the BEIS Greenhouse gas reporting conversion factors for 2021.</p> |
| 17 | <p>In a 2021 report, BEIS used a metric called the levelized cost of hydrogen (LCOH) to compare the cost of different types of hydrogen production technologies. This is defined as the ratio of the total costs of the plant to the total amount of hydrogen expected to be produced over the plant's lifetime.</p> <p>CPI verified this methodology, then determined the LCOH for the PROGREEN technology and compared this to the values obtained from the BEIS report for the alternative technology options.</p> |
| 18 | <p>Lucideon conducted a literature review regarding the Use of Hydrogen as an Alternative Fuel for Ceramic Manufacturing Processes. They concluded that there needs to be work carried out to investigate and overcome the challenges associated with the use of hydrogen an alternative fuel, including:</p> <p>Burner type for burning hydrogen.</p> <p>Higher flame temperature, increased formation of NOx.</p> <p>Effect of moisture content (product of burning hydrogen) on the processing product (ceramics).</p> <p>Effect on refractory material - investigate effect of hydrogen and moisture content.</p> <p>They also concluded that the burner to be used when burning hydrogen should be designed with material that can withstand high temperatures and accommodate high volumetric flowrates associated with hydrogen.</p> |

**This is a University of Hull Report – Confidential Sections
have been removed from the publicly available version of this
report**

Department of Business, Energy, and Industrial Strategy (BEIS)
Funded Project

**A Technical Report on WP1-Deliverables 1.2 and 1.3
Synthesis and characterization of transition metal supported Ammonia
Synthesis Catalysts**

Project Team

A.O.Ibhadon PhD CChem FRSC- Group Leader (**approver/Checker**)

Authors

Xin Zhang (PhD Catalysis for Chemical Synthesis)

Humphrey Okoro (PhD Student, Advanced Materials)

Muhammad Irshad (PhD Student, Ammonia Production & DFT Analysis)

Abdulrazzaq Ahmad (M.Sc Student, Hydrogen Production)

Abstract

The purpose of this draft report is to provide a draft summary of the work that has been carried out on the Synthesis and characterization of transition metal supported Ammonia Synthesis Catalysts under **WP1** on the BEIS supported project on an End-to End Fuel Switching for

Industrial Applications under the BEIS Industrial Hydrogen Accelerator(IHA) programme.

This work is ongoing and includes the synthesis of (Ru/MgO, Ru/Al₂O₃, Ru/SiO₂ and Ru/Mg(OH)₂) using a liquid-phase chemical reduction method. The characterisation of the catalysts is being performed using spectroscopic and microscopic techniques including ICP, XRD, SEM, HRTEM, N₂- BET and EDX techniques. The catalyst synthesized have been forward to partner UNC(University of Newcastle) to test for the production of green ammonia using non-thermal plasma (NTP) catalysis approach. The experimental procedure for the preparation of catalyst is discussed in section 2 of this report. This report also includes the Density Functional Theory (DFT) analysis for the kinetics of catalysts.

1. Introduction

Ammonia, which is one of our most important synthetic chemicals is vital for sustainable global food production. It is a potential carbon-free vector for storing and transporting hydrogen. Ammonia synthesis from the well-known Haber–Bosch (H-B) process ($\text{N}_2 + 3\text{H}_2 \rightarrow 2\text{NH}_3$) requires high temperatures and pressures, an ultrapure H_2 feed, and large centralized production plants (Figure 1a). A green alternative route that has no carbon imprint and centralized ammonia production for ammonia synthesis is urgently sought after as the hydrogen used in the synthesis is currently almost exclusively derived from the reforming of fossil fuels, which results in annual CO_2 emissions of 300 Mt, which is approximately 1.5% of all greenhouse gas emissions. The process predominantly uses water as the hydrogen feedstock and is powered by renewable energy sources.

Photochemical and electrochemical routes, which suppress the competing hydrogen evolution reaction to improve selectivity toward N_2 reduction and/or the design and selection of desirable catalysts have been devised for ammonia synthesis from N_2 and H_2O under mild conditions. The setback with photocatalysis and electrocatalysis is the inability of the electrons transferred to N_2 molecules to provide sufficient energy to break the strong $\text{N}\equiv\text{N}$ bonds with a bond energy of 945 kJ/mol, resulting in a low rate of ammonia yield.

Gas discharge plasmas, can activate inert N_2 molecules into more reactive, vibrationally, or electronically excited states to promote the dissociation of nitrogen molecules, thus, facilitating the breaking of highly stable $\text{N}\equiv\text{N}$ bonds with their highly energetic electrons when electrical energy is applied to a feeding gas. The non-thermal plasma (NTP) is another route to ammonia synthesis where the energy introduced is mainly used to heat the electrons thereby creating thermal none-equilibrium, energy-efficient, and highly reactive environment when coupled with catalysts (plasma catalysis), allowing thermodynamically unfavourable reactions to proceed under ambient temperature and pressure. Electrocatalysis is yet another process, which can be powered by renewable electricity just like the NTP. Despite the encouraging yields of ammonia in NTP, its constraint is that the hydrogen species used is from ultrapure H_2 , which is obtained from cost-demanding electrocatalytic hydrogen evolution reactions (HERs) or carbon-intensive reforming processes. Therefore, the key to making NTP-enabled ammonia synthesis sustainable is replacing H_2 with H_2O , hence, the molecular-level mechanisms

of the synergetic effects of plasma–catalyst interactions for ammonia from N_2 and H_2O must be understood.

The plasma-electrochemical integrated systems utilize the plasma for nitrogen activation and subsequently lower the energy barrier to initiate electrochemical processes for nitrogen fixation was proposed as an alternative way for nitrogen reduction using N_2 and H_2O . A continuous and scalable plasma-electrochemical hybrid technology was developed for sustainable and simplistic production of ammonia through a NO_x intermediary approach with a yield rate of green ammonia of 23.2 mg/h (3.95 g kW/h). Furthermore, a plasma-assisted electrochemical approach where the hydrogen produced from water oxidation is separated from nitrogen activation produced by the low-pressure plasma at 500 °C with an energy efficiency of 0.101 g kW/h was established. A hybrid plasma-thermal catalytic system that combines a plasma-enabled NO_x production and a thermal catalysis process was recently developed with a relatively high gas flow rate of N_2 of 20 L/min and high energy efficiency of 2.94 g kW/h. The upscaling of this technology has been greeted with the relative complexity of the systems and some challenging process conditions such as low pressure, high temperature, or high gas flow rate, resulting in some inevitable environmental challenges.

In this paper, a simple but straightforward one-step process where both the water dissociation and nitrogen activation are driven by the atmospheric NTP under ambient conditions is demonstrated. Reactors with different configurations, catalysts, discharge powers, and gas flow rates were used for the experiment with different H_2O vapor saturations. The optimized configuration of an advanced plasma reactor, packed with ruthenium (Ru) catalyst, showed a remarkable ammonia production rate of 2.67 mmol g/cat./h. The high yield of ammonia was achieved through efficient dissociative adsorption of H_2O and vibrationally excited $N_2(v)$ by the plasma–catalyst interactions, which are predominantly through Eley–Rideal (ER) reactions. The industrial revolution greatly benefits from catalysts in terms of reaction rates and decreased manufacturing costs. Heterogeneous catalysts are widely used in most industries to speed up the reaction rates and lower the cost of the process. Some of the techniques for the preparation of heterogeneous catalysts include the thermal method, calcination, impregnation, and reduction. However, the performance of the catalyst is affected by several factors, including the synthesis techniques and experimental conditions. (Din et al., 2022)

Many catalysis researchers have tried to create new fabrication methods for highly active supported catalysts because no existing approach is adequate for the requirement of high loading and high dispersion of nanoparticles on a carrier material. One of the commonly used techniques for the synthesis of heterogeneous catalysts is by far incipient wetness impregnation. The simplicity of the technical process, low cost, and minimal waste make this technique more attractive. In most cases, support (e.g, MgO, Al₂O₃) is impregnated with a precursor-containing solution. The solution is then dried and the desired product (catalyst) is extracted by additional activation procedures (Sietsma et al., 2006). Another method, namely, the liquid-phase reduction method is one of the simplest approaches for synthesising nanoparticles since it can procure them directly from a variety of precursor molecules (Sunagawa et al., 2008). This method has been recommended due to the addition of reducing agents to control the oxidation of noble metals (Ru, Pd, etc.) at ambient and no limitation for the selection support (Eom et al., 2020).

Ammonia, a carbon-free carrier of hydrogen, has been widely produced using the Haber-Bosch process on large scale. This process requires higher temperature and pressure, and pure hydrogen is usually produced from fossil fuel, which consequently contributes to the emission of CO₂. One alternative for the sustainable production of ammonia is to adopt green methods in the presence of catalysts. Considering that, Zhang et al., (2022) demonstrated a non-thermal plasma (NTP) method for the green production of ammonia at ambient operating conditions with help of a heterogeneous catalyst. The process involved using N₂ and H₂O as the raw materials in the presence of a catalyst in an NTP discharge reactor. Considering the above, this study focused on the preparation of Ru-based catalysts for the synthesis of green ammonia using a nonthermal plasma (NTP) catalysis method.

2. Experimental Section

The Ru-based catalysts were prepared by a liquid-phase chemical reduction method adapting the procedure reported in Liu et al.(2020). The experimental procedure has been explained in the following section.

2.1 Experimental procedure for the synthesis of Ru/MgO, Ru/Al₂O₃, Ru/Mg(OH)₂ and Ru/SiO₂ catalysts

1.0 g magnesium hydroxide MgO as a support was suspended in ultrapure water (100mL) in a round bottom flask, and then stirred for 30 min to form a milky white suspension. In order to promote complete reduction reaction and to ensure uniform Ru(0) particle

growth, an excess amount of sodium borohydride (3, 10, or 30 equivalent with respect to the RuCl_3 salt) as a reducing agent was applied. So 0.02951 g, 0.09836 g or, 0.2955 g (0.78, 2.60, or 7.81 mmol) sodium borohydride (NaBH_4) was dissolved in ultrapure water (10 mL) and then poured into the suspension of MgO at a rate of one drop per second. The mixture was further stirred for 10 min to form a milky white suspension. RuCl_3 solution was prepared by dissolving the known amount of RuCl_3 (0.054 g, 0.26 mmol) in 25 ml distilled water under continuous stirring. Then the uniform RuCl_3 solution was added to the above mixture at a rate of one drop per second and maintained with agitation for 60 min. After the reaction was complete, the solution from step 3 was filtered by Buchner filter and washed many times with ultrapure water. The filtrate was dried under vacuum at 60 °C for 6 h, to yield Ru/ MgO. The same procedure was repeated for the preparation Ru/ Al_2O_3 , Ru/ $\text{Mg}(\text{OH})_2$, and Ru/ SiO_2 catalyst.

The samples were characterized for further analyses using inductively coupled plasma (ICP), X-ray diffraction (XRD), scanning electron microscope (SEM), high-resolution transmission electron microscopy (HRTEM), Brunauer-Emmet-Teller (BET), X-ray photoelectron spectroscopy (XPS), and energy dispersive X-ray (EDX). XRD (PANalytical empyrean series 2) is using Cu-K α radiation at a scan speed of 2 θ /min. SEM (Zeiss EVO60) coupled with electron dispersive spectroscopy (EDS) that performed to determine the % of elements in catalysts.



Figure 1: Ruthenium based Ammonia Synthesis catalyst materials

2.2 Article review

Zhang et al. (2022) reported the production of ammonia using a nonthermal plasma catalysis method, an efficient power-to-chemical transition approach for ammonia synthesis. This method involves using nitrogen (N_2) and water H_2O as the raw materials. The dissociation barriers of NH_3 and H_2O are shown to be lowered by plasma-induced vibrational excitation in the presence of a catalyst in an NTP discharge reactor.

2.2.1 DBD Plasma reactor

Green ammonia was synthesised using nonthermal plasma (NTP) catalysis. DBD plasma reactors were used in this method. The experimental arrangement is reported in (Zhang et al., 2022) and based on the reactor characteristics summarized in table below. A separated-cooling plasma reactor (DBD-W) was used for the primary tests. The reactor consists of stainless-steel rod electrodes, quartz tubes, and grounding copper mesh. The temperature of the reactor and the humidity of inlet nitrogen gas were maintained using an industrial chiller and a water-filled

Drechsel flask, respectively. Two separate mass flow meters were used to slip the gas flow and mix it again into the plasma reactor. The flow rate of N₂ was altered from 0.2 to 1 standard liter per minute (SLM). The amount of water vapor present is expressed as a percentage of relative saturation at the ambient temperature (20°C). The amount of water vapor present is expressed as a percentage of relative saturation at 20 °C.

The complete specification of all the reactors is described in Table 1. All other equipment/devices used in the experimental procedure for the production of ammonia are listed in Table 2.

Table 1 Specifications of all four reactors (Zhang et al., 2022)

| Reactor | Specification |
|----------------|---|
| W-DBD | Stainless steel electrode (6 mm OD, 250 mm length), Quartz tubes (8 mm ID, 10 mm OD, 250 mm length), all-in-one cooling jacket (30 mm OD, 68 mm length), tungsten needle (2 mm ID, 30 mm length) for grounding |
| DBD-W | Stainless steel electrode (6 mm OD, 250 mm length), Quartz tubes (8 mm ID, 10 mm OD, 250 mm length), separate quartz cooling jacket (11.6 mm ID, 34 mm OD, 68 mm length), copper mesh (68 x 180 mm dimension, 0.5 mm thickness) for grounding |
| W-DDBD | Quartz covered stainless steel electrode (quartz: 4 mm ID, 6 mm OD, 200 mm length; steel electrode: 4 mm OD, 250 mm length), all-in-one quartz cooling jacket (30 mm OD, 68 mm length), tungsten needle (2 mm ID, 30 mm length) for grounding |
| DDBD-W | Quartz covered stainless steel electrode (quartz: 4 mm ID, 6 mm OD, 200 mm length; steel electrode: 4 mm OD, 250 mm length), separate quartz cooling jacket (11.6 mm ID, 34 mm OD, 68 mm length), copper mesh (68 x 180 mm dimension, 0.5 mm thickness) for grounding |

Other equipments and their specifications used during nonthermal plasma catalysis for the production of green ammonia are listed in Table 2. DBD reactors and other two types of reactors (W-DDBD and DDBD-W) are illustrated in Figure 2.

Table 2 Equipment used in the production of Ammonia (Zhang et al., 2022)

| Devices | Specifications |
|-----------------------|---|
| Mass flow controllers | Alicat, MC-10SLPM-D, for flow controlling the rate of N ₂ to reactor |

| | |
|--------------------------|--|
| Industrial water chiller | S&A CW-300 with 10 SLM water flow at setting temperature of 20 °C |
| Plasma AC power supply | CTP-2000K from Suman, China with the capability of generating 0-30 kV AC voltage in a range of 1- 40 kHz |

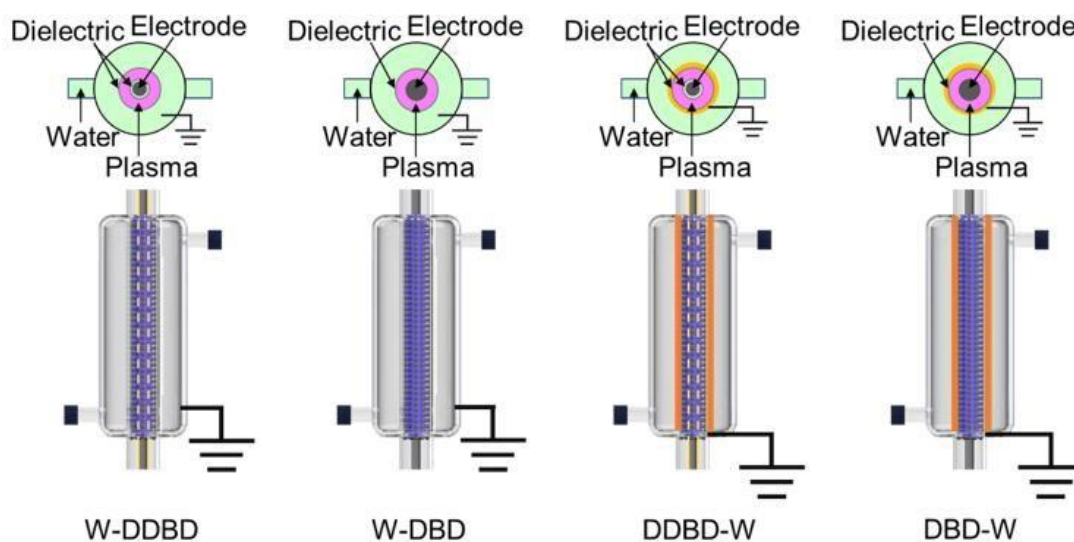

Figure 2: DBD and DDBD reactors (Zhang et al., 2022) (UNC testing for Ammonia generation using catalysts prepared by partner UH)

3. DFT Computational Calculations

This section has been removed from the publicly accessible version of this report.

4. Characterisation of catalysts

XRD measurement

An x-ray diffractometer-Ultima IV (Rigaku, Japan) was used to investigate the crystalline degree and structures of the samples with Cu K α radiation as the x-ray source (30nA and 40kV).

The X-ray patterns were obtained at 2 θ scanning range of 10o-90o. The thermal stability of the Ru/Mg(OH)₂ sample was determined by the thermal-gravity (TG) analysis (TG 209F1). The structure and morphology of the sample was further characterized by SEM

(MLA650F, FEI), TEM (TECNAI F30, 300 kV, FEI) and high-resolution TEM (HRTEM) (TECNAI F30, 300 kV, FEI). To further prove the structure and elemental distribution of the Ru/Mg(OH)₂ sample, scanning TEM, (STEM) and STEM-EDX elemental analysis (mapping and line scanning) were performed using a TECNAI F30. To acquire the chemical state of the elements and their surface composition, X-ray photoelectron spectroscopic (XPS) test were performed using a PHI Quantum 2000 equipment with a monochromatic Al K α X-ray source. The XRD data for the metal oxide supported Ru catalyst materials is presented in the table 4 below

Table 4 -Raw XRD Data for Metal Oxide supported Ru based catalysts

| auto-5to80-30min_1 | Ru/MgO 30min_RuAl ₂ O ₃ | Ru/Al ₂ O ₃ 30min_RuMg(OH) ₂ |
|--------------------|---|---|
| 5.01293028 | 97 | 110 |
| 5.03919085 | 108 | 104 |
| 5.06545142 | 87 | 122 |
| 5.09171199 | 87 | 109 |
| 5.11797256 | 90 | 120 |
| 5.14423313 | 92 | 112 |
| 5.1704937 | 97 | 112 |
| 5.19675427 | 96 | 116 |
| 5.22301484 | 96 | 108 |
| 5.24927541 | 108 | 125 |
| 5.27553598 | 100 | 124 |
| 5.30179655 | 97 | 147 |
| 5.32805712 | 97 | 127 |
| 5.35431769 | 96 | 135 |
| 5.38057826 | 133 | 135 |
| 5.40683883 | 100 | 110 |
| 5.4330994 | 99 | 127 |
| 5.45935997 | 99 | 124 |
| 5.48562054 | 112 | 125 |
| 5.51188111 | 98 | 129 |
| 5.53814168 | 126 | 136 |
| 5.56440225 | 104 | 128 |
| 5.59066282 | 115 | 137 |
| 5.61692339 | 113 | 141 |
| 5.64318396 | 137 | 113 |
| 5.66944453 | 119 | 128 |
| 5.6957051 | 117 | 142 |
| 5.72196567 | 125 | 142 |
| 5.74822624 | 114 | 125 |
| 5.77448681 | 91 | 148 |
| 5.80074738 | 120 | 162 |
| 5.82700795 | 122 | 129 |
| 5.85326852 | 116 | 135 |

| | | | | |
|------------|-----|------------|-----|------------|
| 5.87952909 | 105 | 5.87952909 | 155 | 5.87952909 |
| 5.90578966 | 118 | 5.90578966 | 144 | 5.90578966 |
| 5.93205023 | 116 | 5.93205023 | 118 | 5.93205023 |
| 5.9583108 | 106 | 5.9583108 | 155 | 5.9583108 |
| 5.98457137 | 149 | 5.98457137 | 147 | 5.98457137 |
| 6.01083194 | 117 | 6.01083194 | 141 | 6.01083194 |
| 6.03709251 | 127 | 6.03709251 | 137 | 6.03709251 |
| 6.06335308 | 112 | 6.06335308 | 141 | 6.06335308 |
| 6.08961365 | 112 | 6.08961365 | 146 | 6.08961365 |
| 6.11587422 | 111 | 6.11587422 | 133 | 6.11587422 |
| 6.14213479 | 110 | 6.14213479 | 139 | 6.14213479 |
| 6.16839536 | 130 | 6.16839536 | 138 | 6.16839536 |
| 6.19465593 | 124 | 6.19465593 | 152 | 6.19465593 |
| 6.2209165 | 112 | 6.2209165 | 160 | 6.2209165 |
| 6.24717707 | 114 | 6.24717707 | 141 | 6.24717707 |
| 6.27343764 | 120 | 6.27343764 | 155 | 6.27343764 |
| 6.29969821 | 109 | 6.29969821 | 151 | 6.29969821 |

4.1 SEM and EDS Analysis – This section has been removed from the publicly accessible version of this report.

Acknowledgment

Funding from BEIS for this project is gratefully acknowledged.

References

Din, I. U., Nasir, Q., Garba, M. D., Alharthi, A. I., Alotaibi, M. A. & Usman, M. (2022) A review of preparation methods for heterogeneous catalysts. *Mini-Reviews in Organic Chemistry*, 19(1), 92-110.

Eom, H., Hwang, I.-h., Lee, D. Y., Lee, S. M. & Kim, S. S. (2020) Preparation of liquid-phase reduction method-based Pt/TiO₂ catalyst and reaction characteristics during HCHO roomtemperature oxidation. *Industrial & Engineering Chemistry Research*, 59(35), 15489-15496.

Sietsma, J. R., van Dillen, A. J., de Jongh, P. E. & de Jong, K. P. (2006) Application of ordered mesoporous materials as model supports to study catalyst preparation by impregnation and drying, *Studies in surface science and catalysis* Elsevier, 95-102.

Sunagawa, Y., Yamamoto, K., Takahashi, H. & Muramatsu, A. (2008) Liquid-phase reductive deposition as a novel nanoparticle synthesis method and its application to supported noble metal catalyst preparation. *Catalysis today*, 132(1-4), 81-87.

Zhang, T., Zhou, R., Zhang, S., Zhou, R., Ding, J., Li, F., Hong, J., Dou, L., Shao, T. & Murphy, A. B. (2022) Sustainable Ammonia Synthesis from Nitrogen and Water by One-Step Plasma Catalysis. *Energy & Environmental Materials*.

Appendix 3

PROGREEN PROJECT

Short report on

Design of Non-thermal plasma (NTP) process for water desalination and sizing, modelling and validation of NTP reactor for ammonia production

Process and Energy Systems Engineering Research Group

Chemical and Biological Engineering University of Sheffield

12 February 2023

Prepared by: Dr Olajide Otitoju

Checked by: Prof. Meihong Wang

Summary

This report highlights the design of the water desalination process with a capacity to capture 25.2 m³/h using non-thermal plasma (NTP). Detailed mass and energy balances are carried out to determine the mass flow rates, energy flows and heat duties of process equipment. Results show that about 1400.35 kWh of energy is consumed per cubic meter of water desalinated. Also, the report discusses the sizing of an NTP reactor for the production of ammonia. The sizing is based on Chemical Engineering principles. Results show that an NTP reactor of inner diameter of 0.08m, outer diameter of 0.1003 m and a length of 0.301 m will be required for the ammonia production process. The size of the NTP reactor depends on the gas volumetric flow rate. Thus the size of the reactor is influenced by the gas volumetric flow rate. A steady-state lump sum model of the NTP reactor was developed and validated with experimental data. The model predictions agree with the experimental measurements.

1. Design of the Non-thermal plasma (NTP) Desalination process

The NTP desalination process vaporizes sea water using atmospheric-pressure plasma (APP). The vaporised water is then condensed and cooled to obtain make pure water. Approximately 70% of the sea is desalinated in this way. The remaining mixture of water and salt (brine) is cooled to 30 °C by mixing with seawater and returned to the sea. The NTP desalination process can produce 25.2 m³/h of pure water. The process flow diagram (PFD) of the NTP process is shown in Figure 1.

Assumptions

- Sea water contains 3.5 wt% salts (assume it is all NaCl) and is available at a design the temperature of 15 °C.
- The datum is 15 °C. That is, each stream has enthalpy according to its temperature above this value and specific heat, plus any enthalpy of vaporization.
- Systems operate at a steady state
- No heat loss to the surrounding
- Desalination time of 900 s (chosen based on the experimental report)
- Operating at constant pressure

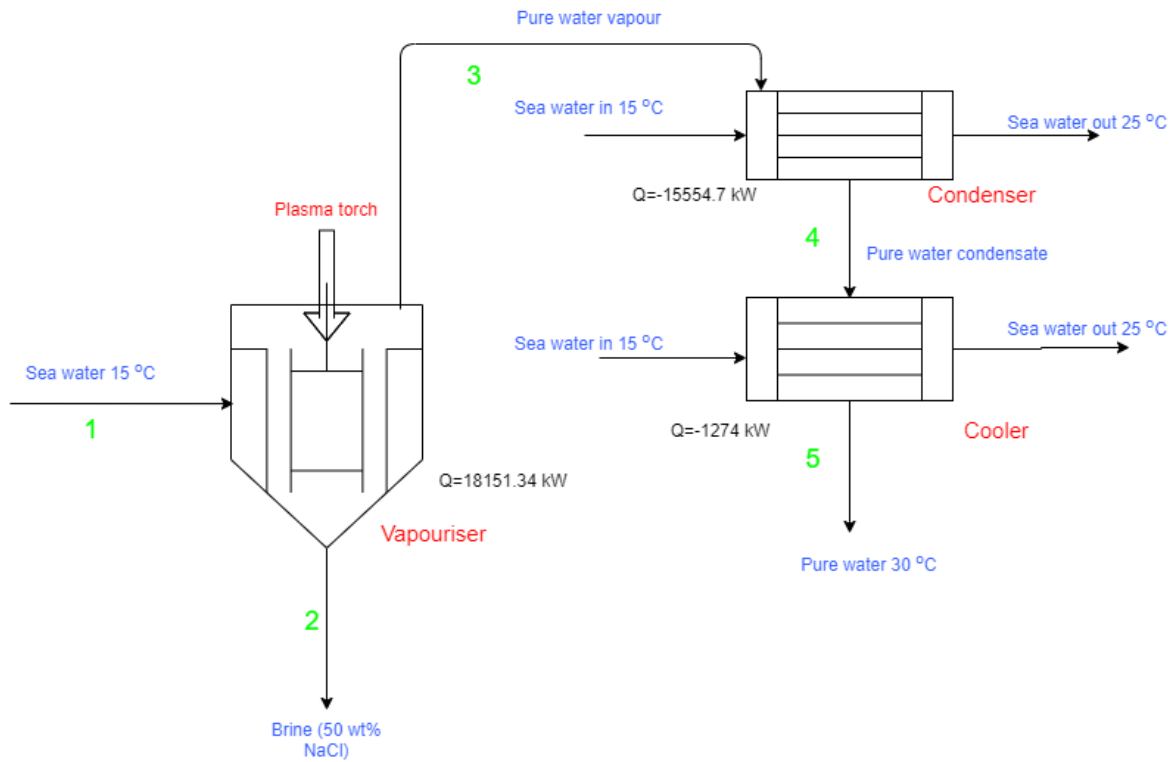

Fig. 1: A simple PFD of the NTP desalination process

Firstly, we started by calculating the mass flow rate and the enthalpy in each independent stream. From the given information, we have come up with the best solution of using mass and energy balances to solve the task. For the mass balances, this is the general equation used;

$$\sum_{in} \dot{m} = \sum_{out} \dot{m} \quad (1)$$

Where \dot{m} is the mass flow rate in kg/s.

For the energy balances, this is the general equation used at constant pressure;

$$\sum_{out} \Delta H - \sum_{in} \Delta H = Q \quad (2)$$

Where ΔH is the change in enthalpy (kJ/s). Assuming plasma heating and that the bubble evaporation is successful in each cycle, part of the total load energy is stored as enthalpy to bubble evaporation. It is calculated thus;

$$\Delta H = \dot{m}(C_p \Delta T + \Delta H_{vap}) \quad (3)$$

where C_p is the specific heat capacity (kJ/kgK), ΔT represents the difference between the vapour temperature and the ambient water temperature and ΔH_{vap} is the enthalpy of the phase transition, which is equal to 2280 k J/kg. The specific heat capacity of each stream was calculated with this empirical relation obtained from the regression analysis carried out on saturation concentration data for NaCl solution [1].

$$C_p = 4180 - 4.396 \left(\frac{S}{100}\right) \rho + 0.0048 \left(\frac{S}{100}\right)^2 \rho^2 \quad (4)$$

The stream densities are determined from the following polynomial representation.

$$\rho = a_1 + a_2 T + a_3 T^2 + a_4 T^3 \quad (5)$$

Where S is the Salinity in per cent by weight and T is the temperature in °C. The constants a_1 to a_4 in Eq. 5 are determined based on S using the approach described by Ramalingam et al. [1]. The summary of the design for the NTP desalination process is shown in Table 1.

Table 1 Summary of the NTP process and equipment duties and energy consumption

| | seawater | Brine | Pure water vapour | Pure water condensate | Cooled pure water |
|---------------------------------|----------|-------|-------------------|-----------------------|-------------------|
| Stream | 1 | 2 | 3 | 4 | 5 |
| Temperature oC | 15 | 75 | 75 | 75 | 30 |
| Pressure (Bar) | 1 | 0.729 | 0.729 | 1 | 1 |
| Volume flow (m ³ /s) | 0.01 | 0.003 | 0.007 | 0.007 | 0.007 |
| salinity (wt%) | 3.5 | 30 | 0 | 0 | 0 |

| | | | | | |
|---|---------|-------------|----------|---------|--------|
| water comp (wt%) | 96.5 | 70 | 100 | 100 | 100 |
| Density (kg/m ³) | 1024.36 | 1556.884517 | 974.61 | 974.61 | 995.70 |
| Total Mass flow rate(kg/s) | 10.24 | 4.67 | 6.82 | 6.82 | 6.97 |
| Flow rate of water (kg/s) | 9.88 | 1.87 | 6.82 | 6.82 | 6.97 |
| Flow rate of Nacl (kg/s) | 0.36 | 2.80 | 0 | 0 | 0 |
| Specific heat capacity Cp (kJ/kgK) | 4.03 | 4.26 | 4.18 | 4.18 | 4.18 |
| Enthalpy (kg/s) | 0 | 1194.39 | 17265.73 | 1711.02 | 437.01 |
| <hr/> | | | | | |
| Vapouriser duty (kW) | | 18460.11 | | | |
| Condenser duty (kW) | | -15554.71 | | | |
| Cooler duty (kW) | | -1274.00 | | | |
| <hr/> | | | | | |
| Desalination Energy consumption (kWh/m ³) | | 1400.35 | | | |
| <hr/> | | | | | |

2. Design of the Non-thermal plasma (NTP) reactor for ammonia production

The dielectric barrier discharge (DBD) reactor is the chosen reactor for ammonia production. This is because it is the most popular configuration to generate NTP. In DBD, a high-voltage electrode is inserted along the reactor axis, while a grounded electrode is wrapped around the reactor walls (Fig 2). Gas flows through the cylindrical chamber. Plasma is formed between the dielectric layer and the high-voltage electrode.

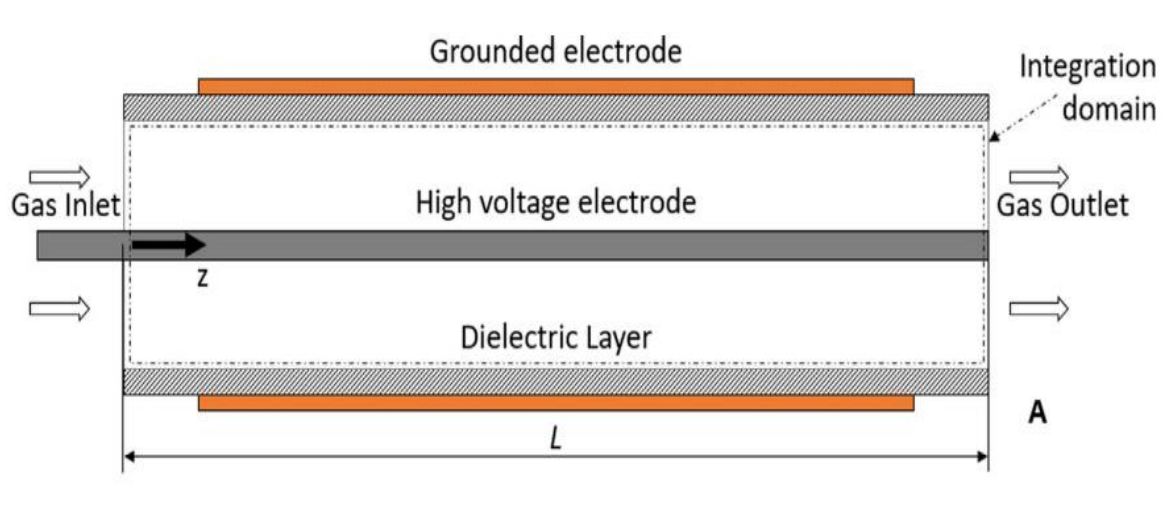

Fig 2. Schematic of the DBD NTP reactor

The DBD is assumed to be a packed bed reactor (PBR). Thus the following algorithm is used in the design of the reactor.

Assumptions

- Concentration and temperature are only present only in the axial direction.
- First order reaction
- There is no volumetric expansion in the reactor

Mole balance

The mole balance of specie in the PRB reactor is expressed as follows

$$\frac{dC_{ab}}{dz} = - \left(\frac{\Omega \rho_b k'' S_a C_{ab}}{U} \right) \quad (6)$$

Where Ω is the overall effectiveness factor, ρ_b is the bulk density of the catalyst, k'' is the specific reaction constant, S_a is the surface area per unit weight of the catalyst, C_{ab} is the bulk concentration and U is the superficial velocity in the reactor.

The weight (w) of the catalyst in the reactor is given by

$$w = \rho_b A_c Z \quad (7)$$

Where A_c is the cross-sectional area of the reactor and Z is the corresponding position of the catalyst. Therefore, Eq 6 becomes;

$$\frac{dC_{ab}}{dw} = - \left(\frac{\Omega \rho_b k'' S_a C_{ab}}{U \rho_b A_c} \right) \quad (8)$$

$$\frac{dC_{ab}}{dw} = - \left(\frac{\Omega k'' S_a C_{ab}}{v} \right) \quad (9)$$

Where v is the volumetric flow rate. Assuming that at $v = v_o$ $w = 0$ and $C_{ab} = C_{ab,o}$

$$\text{Conversion } (X) = 1 - \frac{C_{ab}}{C_{ab,o}} \quad (10)$$

Substituting Eq 10 for C_{ab} into Eq 9 and integrating yields

$$W = \frac{v_o}{\Omega k'' S_a} \ln \left(\frac{1}{1 - X} \right) \quad (11)$$

With Eq. 11, the weight of the catalyst that is required for a particular conversion can be estimated.

The length of the reactor required for a given cross-section is estimated from Eq 12.

$$l = \frac{W}{A_c \rho_b} \quad (12)$$

By using the “rule of thumb” that the ratio of the length to diameter is 3, i.e $\frac{l}{D} = 3$, and that $A_c = \frac{\pi D^2}{4}$, then, the diameter of the reactor is determined with Eq 13.

$$D = \sqrt[3]{\frac{4W}{3\pi\rho_b}} \quad (13)$$

The key dimensions of the designed NTP reactor are shown in Table 1

Table 1 Parameters of the NTP reactor

| Reactor | Unit | Value |
|----------------|------|--------|
| Inner diameter | mm | 80.2 |
| Outer diameter | mm | 100.25 |
| Length | mm | 300.75 |

3. Model development and validation of the NTP reactor

3.1 Model equations

3.1.1 Mass balance

$$\frac{\partial \rho_i}{\partial \tau} = \delta_i \quad (14)$$

$\partial \rho_i$ is the rate of change of species (neutral, charged, radical or excited species) density. τ is the residence time (s), δ_i is a mass source term (kg/m³s). It is evaluated as the sum of production and loss terms of each species as follows:

$$\delta_i = \sum_j^{n_r} [v_{ij} R_j] \cdot MM_i \quad (15)$$

Where v_{ij} is the stoichiometric coefficient of specie i in reaction j , R_j is the reaction rate of reaction j (mol/m³s) and MM_i is the molar mass of specie i (kg/mol).

$$R_j = k_j \prod_k^{n_{sp}} [C_k]^{v_{kj}} \quad (16)$$

3.1.2 Gas energy balance

$$\frac{\partial}{\partial \tau} (\rho C_p T_g) = \dot{Q}_{plasma} + \sum_i^{nr} (-\Delta H_{r,i}^o R_i) - \dot{Q}_{diss} \quad (17)$$

The LHS of Eq. (17) is the rate of change of internal energy, $\Delta H_{r,i}^o$ is the reaction enthalpy. \dot{Q}_{diss} is the heat dissipated at the reactor walls through conduction. T_g is the temperature of gas species, C_p is the heat capacity of the mixture (J/kgK). The electron density was estimated with Eq 18.

$$\frac{\partial \varepsilon}{\partial t} = \frac{\partial \Gamma_\varepsilon}{\partial z} + \dot{Q}_{v,gen} - \dot{Q}_{elastic} - \dot{Q}_{e,gen} - \dot{Q}_{reaction} - Q_{wall\ loss} \quad (18)$$

3.1.3 Catalytic Reaction Calculations

$$\text{Specific energy input (SEI)} (\text{kJ L}^{-1}) = \frac{P_{\text{discharge}}}{Q_{\text{gas}}} \quad (19)$$

$$\text{Energy consumption: } E_{\text{NH}_3} (\text{kg kWh}^{-1}) = \frac{C_{\text{NH}_3} \cdot V}{t \cdot P_{\text{discharge}} \cdot m_{\text{cat}}} \quad (20)$$

Where $P_{\text{discharge}}$ is the discharge power, Q_{gas} is the gas (N_2) flow rate, C_{NH_3} is the concentration of ammonia generated in the plasma process, and m_{cat} is the mass of packed catalysts.

$$\text{The concentration of NH}_3 \quad C_{\text{NH}_3} = \frac{\text{Rate}_{\text{NH}_3} (\mu\text{mol/h})}{\text{Flow}_{\text{N}_2} (\text{L/min}) \div 24.5 (\text{L/mol}) \times 60 (\text{min/h}) \times 10^6 (\mu\text{mol/mol})} \quad (21)$$

$$\begin{aligned} &\text{The production rate of N}_2\text{O} = \\ &\frac{\text{Conc.}_{\text{N}_2\text{O}} (\text{ppm}) \times \text{Flow}_{\text{N}_2} (\text{L/min}) \div 24.5 (\text{L/mol}) \times 60 (\text{min/h}) \times 10^6 (\mu\text{mol/mol})}{1,000,000 (\text{ppm})} \end{aligned} \quad (22)$$

$$\begin{aligned} &\text{The total N}_2 \text{ conversion rates: } \text{Conversion Rate}_{\text{N}_2} = \\ &\frac{\text{Rate}_{\text{NH}_3} (\mu\text{mol/h}) \div 2 (\text{mol NH}_3 / \text{mol N}_2) + \text{Rate}_{\text{N}_2\text{O}} (\mu\text{mol/h}) \div 1 (\text{mol N}_2\text{O} / \text{mol N}_2)}{\text{Flow}_{\text{N}_2} (\text{L/min}) \div 24.5 (\text{L/mol}) \times 60 (\text{min/h}) \times 10^6 (\mu\text{mol/mol})} \times 100\% \end{aligned} \quad (23)$$

The overall reaction of the ammonia synthesis is as follows;



The catalyst (Ru/MgO) used in the experiment is used in the model of the NTP reactor.

Table 2: Catalyst and process parameters for ammonia synthesis

| | |
|---|--------|
| Process parameters | Value |
| catalyst | Ru/MgO |
| Total mass of Catalyst (g) ^a | 0.13 |

| | | |
|---|--------------------------------------|--------|
| Component mass of catalyst (g) | Ru ^b | 0.0065 |
| | MgO | 0.124 |
| Relative humidity (%) | % | 100 |
| N ₂ conversion (%) | % | 0.03 |
| Inlet flow rate (L/min) | N ₂ | 1 |
| | H ₂ O vapour ^c | 0.02 |
| Total inlet flow (L/min) | | 1.02 |
| Composition (vol%) | N ₂ | 98.04 |
| | H ₂ O vapour | 1.96 |
| Power discharge | watt | 70 |
| N ₂ consumption (mol _{N2} /mol _{NH3}) | | 2 |
| H ₂ O vapour consumption (mol _{H2O} /mol _{NH3}) | | 1.5 |
| Pressure (bar) | % | 1 |
| Inlet temperature (K) | 293 | 293 |

^aCalculated using Eq 11. It is dependent on the conversion in the NTP reactor. This means, the higher the conversion, the higher the mass of the catalyst required.

^bEstimated based on 5 wt% Ru content achieved in the experiment [2]

^cEstimated using the ideal gas law based on 100% relative humidity

The results from the model are compared to the experiment from Zhang et al. [2] in Table 3 below. The model correctly predicted the NH₃ production rate, reactor outlet temperature and energy consumption.

Table 3 Comparison of experimental results with model predictions

| | Experiment [2] | Model predictions |
|---|----------------|-------------------|
| NH ₃ Production rate (mmol/g _{cat} h) | 2.67 | 2.75 |
| Energy consumption (kWh/kg NH ₃) | 15459 | 15462 |
| Plasma reactor outlet temperature °C | 200 | 202 |
| N ₂ O production rate (mmol/h) | 0.594 | 0.62 |
| SEI (kJ/L) | 4.20 | 4.20 |
| N ₂ conversion (%) | 0.0297 | 0.0315 |

4. Conclusion

In this report, the procedures to design an NTP-based desalination process to produce 25 m³/h of pure water have been described. The sizing of the NTP reactor for the production of ammonia is also described. Based on the results obtained from the calculations performed in this report, an NTP reactor diameter of 0.101 m and length of 0.3 m will be required for the ammonia production process. The steady-state model of the NTP reactor was developed and validated. The model predictions agree with the experimental data, thus confirming the reliability of the model.

References

- [1] Ramalingam A, Arumugam S. Experimental study on the specific heat of hot brine for salt gradient solar pond application. *Int J ChemTech Res* 2012;4:956–61.
- [2] Zhang T, Zhou R, Zhang S, Zhou R, Ding J, Li F, et al. Sustainable Ammonia Synthesis from Nitrogen and Water by One-Step Plasma Catalysis. *Energy Environ Mater* 2022:1–9. doi:10.1002/eem2.12344.

Appendix 4

Executive Summary in Lieu of Full Report

The UK ceramics manufacturing industry is a large emitter of carbon dioxide, principally due to the large quantity of natural gas that is used in the firing of ceramic products.

Replacing natural gas with hydrogen for firing is a potential means to reduce CO₂ emissions from the ceramic industry.

One of Lucideon's roles within the PROGREEN project was to engage with ceramic producers to understand the technical challenges that H₂ firing might raise.

A questionnaire was sent to 34 manufacturers from across the UK ceramics sector, and their responses were used to produce a test plan. Strength, water absorption, shrinkage and colour were the most critical properties, and these were considered in the plan.

As well as the test plan, the responses gave insight into what monitoring equipment would be required for a H₂ test kiln. Gas sensors, temperature profile measurement and flue after burner are all factors that will need to be included in the furnace design.

Meetings were held with selected manufacturers to give a summary of the PROGREEN project as a whole, and to better understand their requirements.

Outside of the scope of PROGREEN, health and safety, infrastructure, regulations, and the cost of hydrogen alongside the cost of new equipment or upgrading old kilns were common concerns.

From engagement with the UK ceramics manufacturing industry, a test plan has been produced, which will investigate the effect of firing with H₂ on critical ceramic properties and explore possible limitations.

Appendix 5



Hydrogen Test Kiln Report

Author: Mick Hughes

Reviewer: Brandon Pilfold

Therser (UK) Ltd
Walley Street,
Burslem,
Stoke on Trent,
Staffordshire,
ST6 2AH, UK

Therser Hydrogen Test Kiln Report



Therser have built a test kiln with the ability to test combustion of 100 % Hydrogen and % mixes of natural gas and hydrogen

The burner used for testing was an ESA Pyronics 301NM suitable for 100% hydrogen.

Burner was rated at 75kw @ Natural Gas Supply

Based on delivery schedules to meet testing date the gas train for hydrogen feed was constructed using Atex rated controls and valves from Dungs.

CFD analysis was carried out to ascertain best design for kiln. Screen shot of results shown on following pages

Kiln was lined with various grades of refractory brick and fibre to ascertain any reaction to combustion of 100% hydrogen

Due to restriction of flow from compressed gas manifold a maximum

flow rate of 15.2 NM³/Hr was achieved.

A maximum temperature of 965 C was reached

8 CFD Analysis

The following images show various elevations of test kiln detailing flow distribution of air circulating during firing.

The legend shows velocities in m/s. The colour gradient showing results

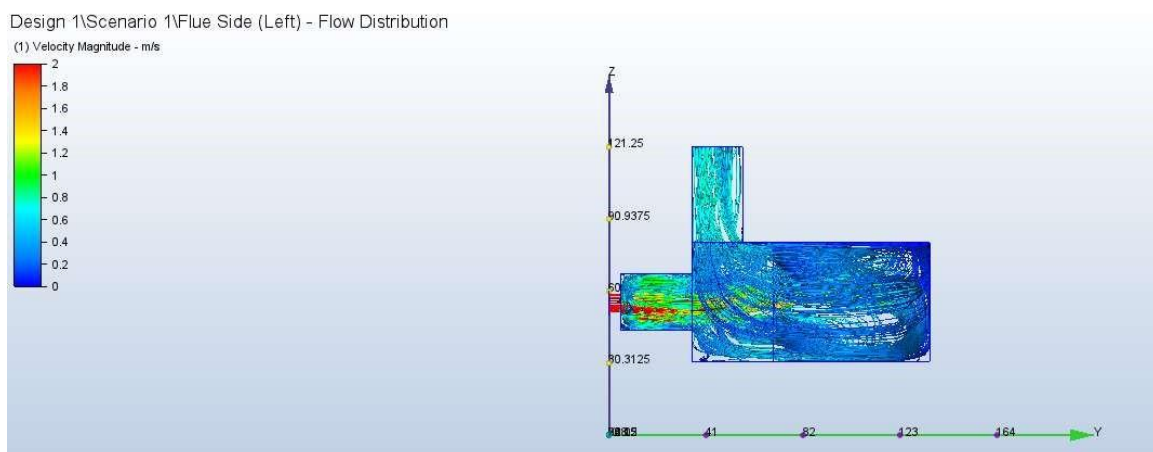
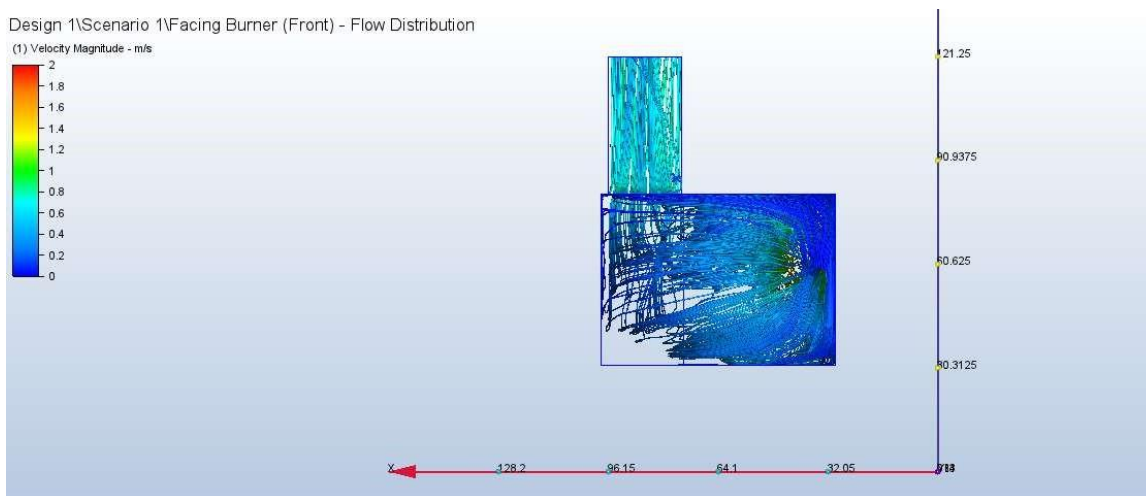
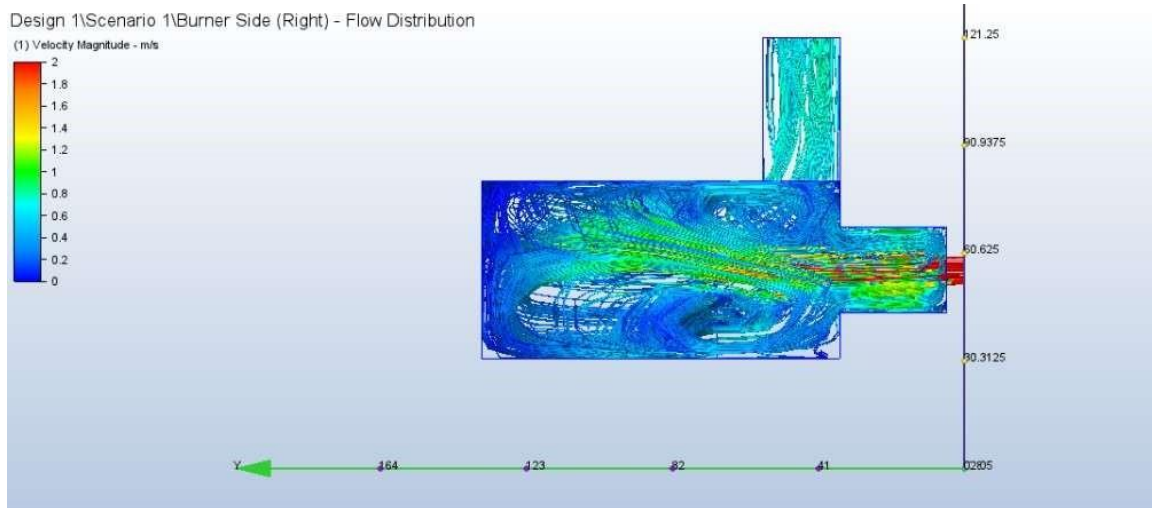

Design 1\Scenario 1\Top - Flow Distribution

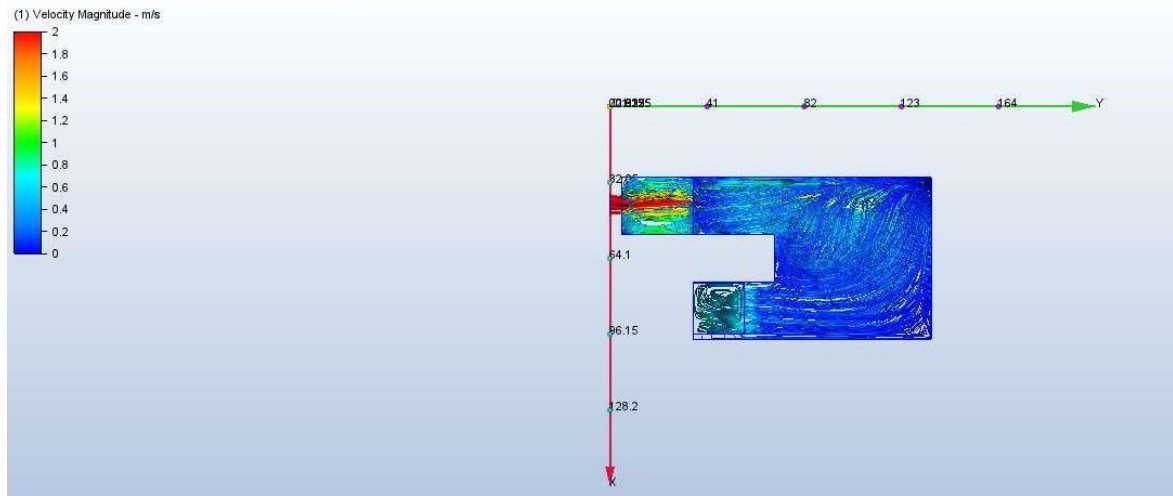

Design 1\Scenario 1\Burner Side (Right) - Velocity

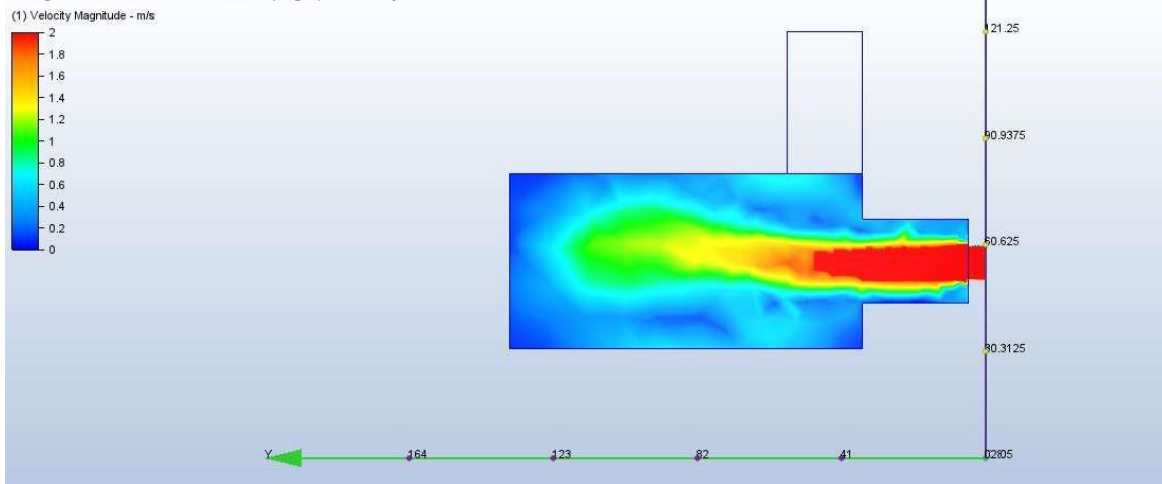

Design 1\Scenario 1\Facing Burner (Front) - Velocity

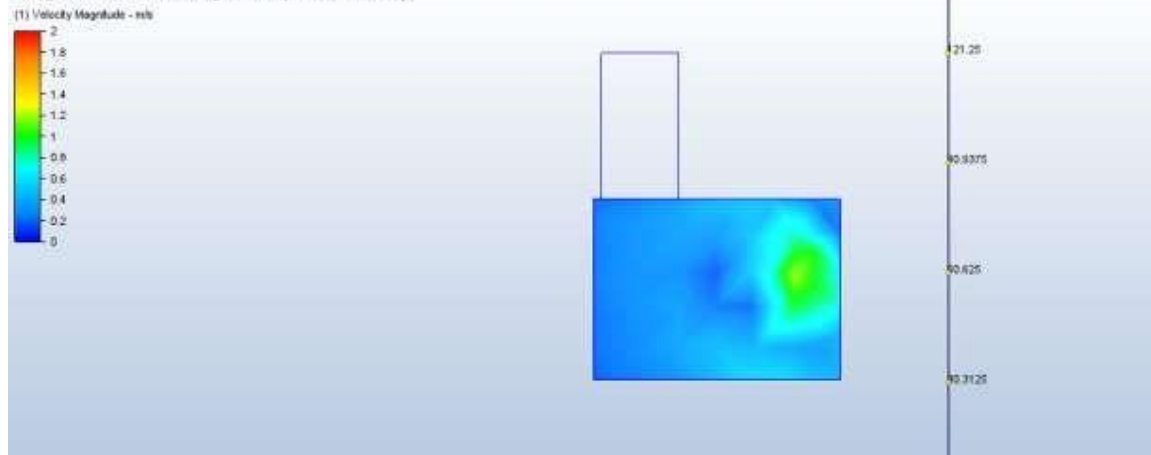

Design 1\Scenario 1\FIux Side (Left) - Velocity

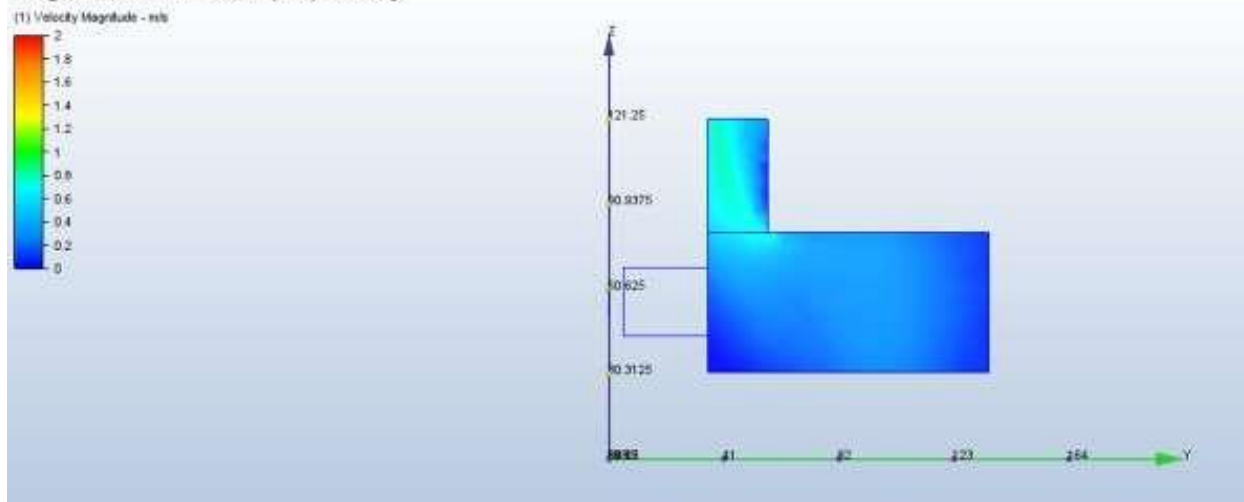

Design 1\Scenario 1\Top - Velocity

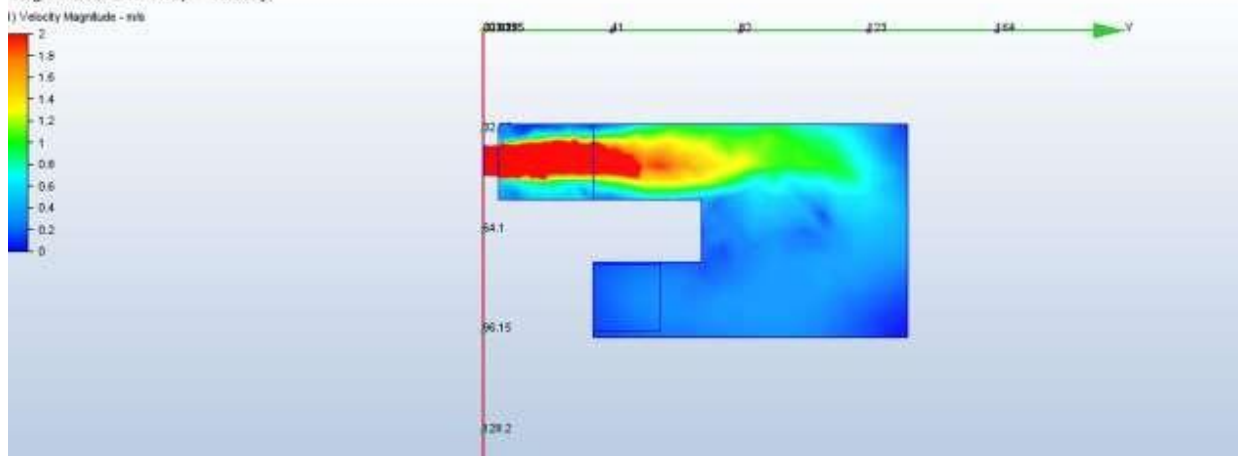

9 Kiln Arrangement Drawing

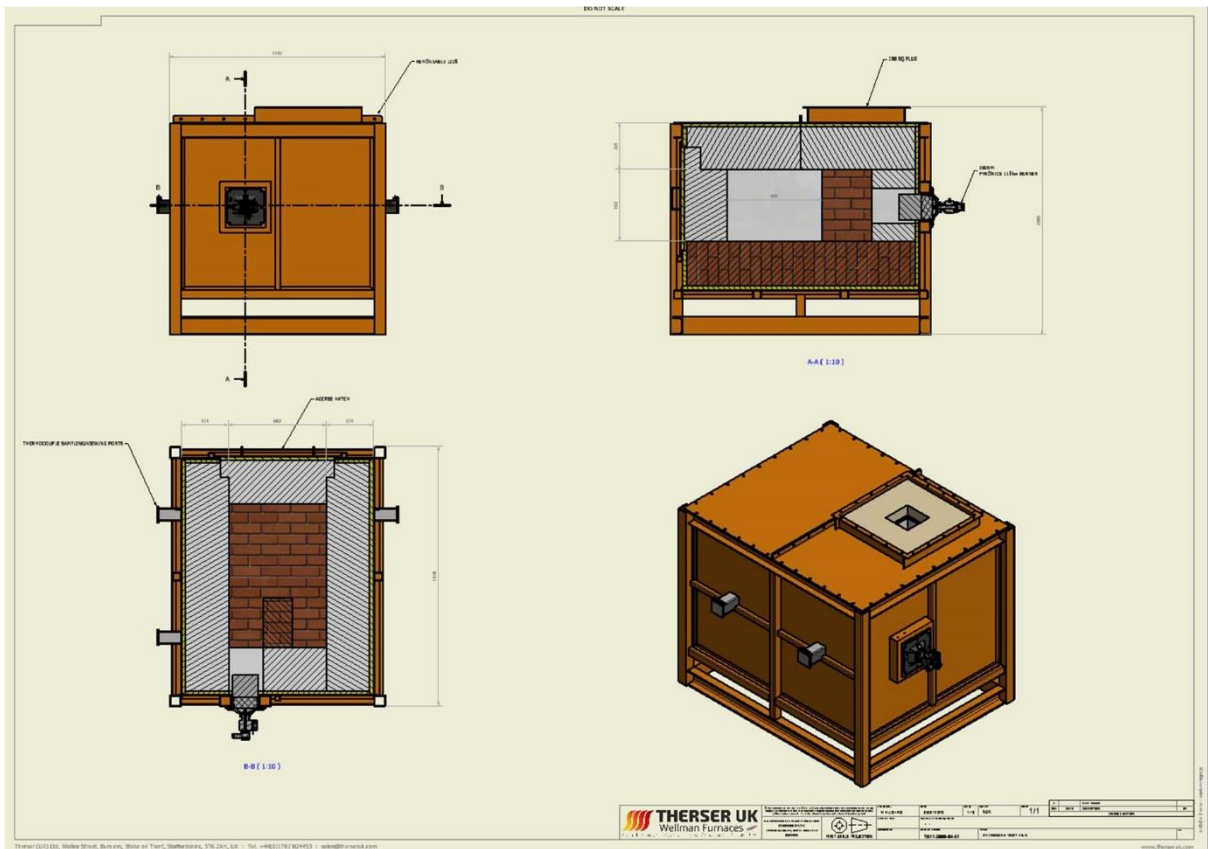

Kiln Casing Detail

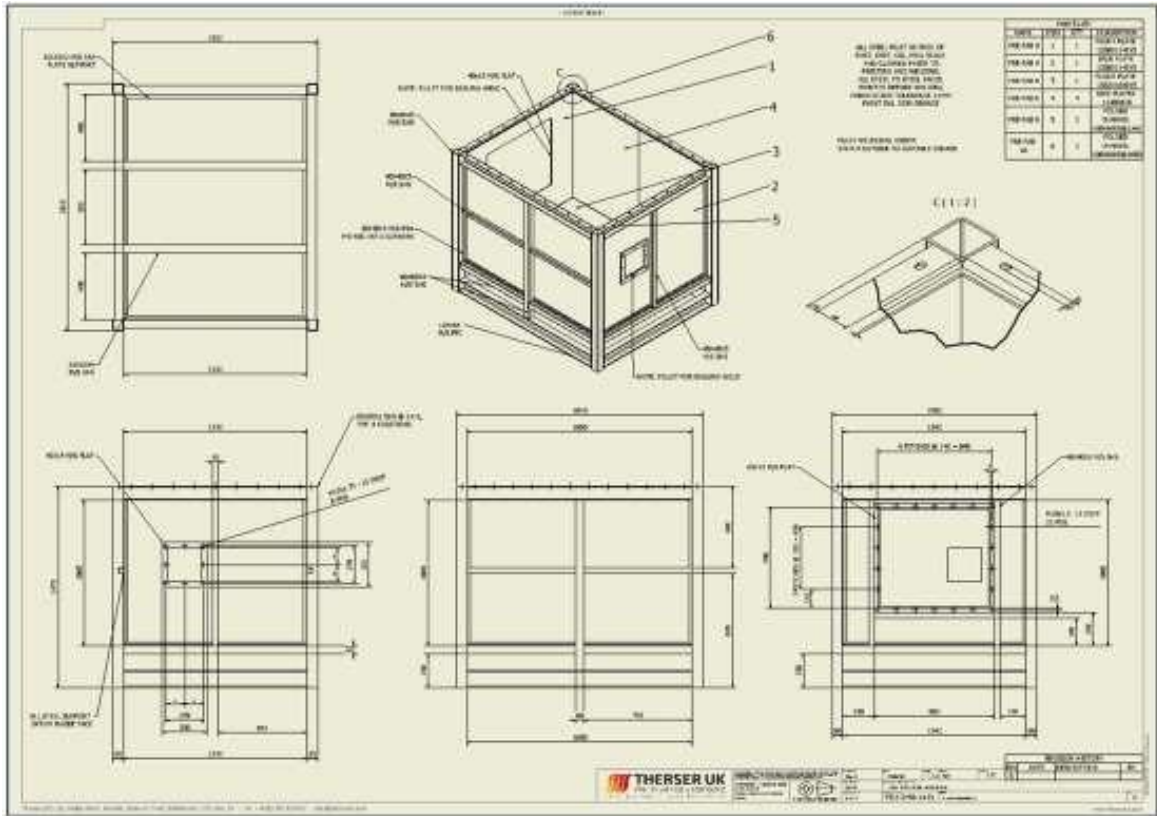

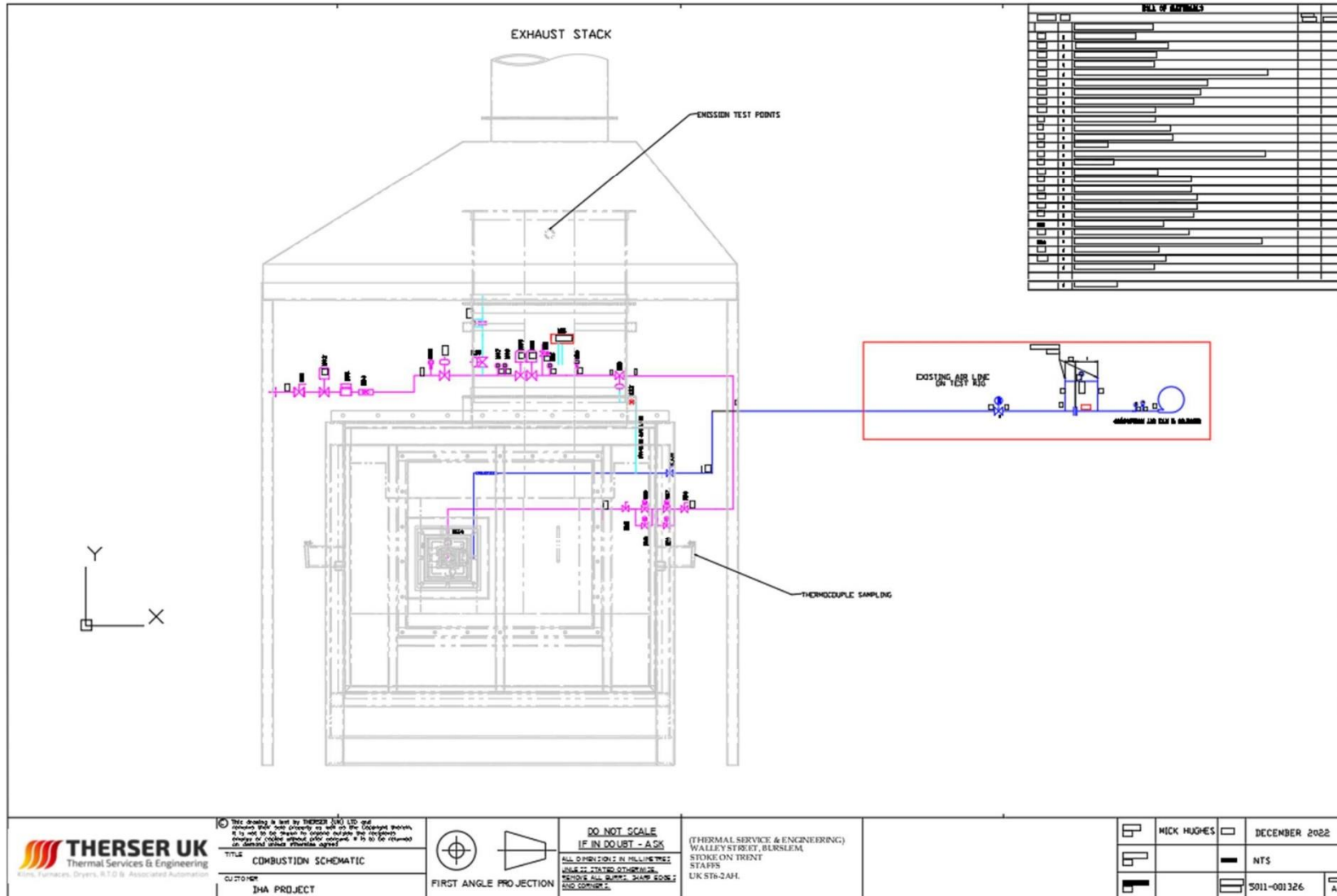

Combustion Schematic



Kiln in location



TEST KILN FIRING 100% HYDROGEN

DATE OF TEST: 10 JANUARY 2023

TIME: 8.30AM

| TIME | TEMP DEG C | CO (ppm) | CO2 (%) | O2 (%) | CO (mgm3) | NO (mgm3) | NOx (mgm3) | SO2 (mgm3) |
|---------|------------|----------|---------|--------|-----------|-----------|------------|------------|
| 9.30am | 750 | 11 | 0.4 | 20.2 | 0 | 96 | 125 | 11 |
| 10.15am | 896 | 6 | 0.3 | 20.5 | 15 | 101 | 131 | 0 |
| 11.00am | 965 | 0 | 0.2 | 20.5 | 0 | 112 | 146 | 22 |

Burner Settings

| | | |
|---------------------------|-------|--------|
| Capacity | 45.6 | kw |
| H2 Flow | 15.2 | Nm3/hr |
| Burner Air Pressure | 7.5 | mbar |
| H2 Used | 45.18 | Nm3 |

TEST KILN FIRING NATURAL GAS

DATE OF TEST: 07 FEBRUARY 2023

TIME: 10.30 AM

| TIME | TEMP DEG C | CO2 (%) | O2 (%) | CO (mgm3) | NO (mgm3) | NOx (mgm3) | SO2 (mgm3) |
|---------|------------|---------|--------|-----------|-----------|------------|------------|
| 11.00am | 703 | 6.4 | 9.7 | 0 | 42 | 54 | 0 |
| 11.30am | 747 | 5.7 | 10.9 | 0 | 36 | 46 | 0 |
| 12.00am | 784 | 6.5 | 9.4 | 0 | 42 | 54 | 0 |
| 12.30pm | 802 | 6.7 | 9.2 | 0 | 42 | 54 | 0 |
| 1.00pm | 819 | 6.5 | 9.4 | 2 | 40 | 51 | 0 |
| 1.30pm | 830 | 6.7 | 9.2 | 0 | 42 | 54 | 0 |

Burner Settings

| | | |
|---------------------------|------|--------|
| Capacity | 45.6 | kw |
| Gas Flow | 5.4 | Nm3/hr |
| Burner Air Pressure | 5.9 | mbar |
| Gas used | 17 | Nm3 |



Area a burner. No damage viewed



Area at side burner no damage viewed



Area opposite burner. Slight singeing and fluffing of fibre due to velocity of burner flame.

Following test, no visible significant damage to refractory and fibre was viewed.

No cracks in brickwork or spalling. Fibre was dry, and although some water was noticed on sampling tube when testing for emissions, the fibre had no water damage.

It must be noticed that test had maximum temperature of 965⁰ C. Further tests will be carried out to achieve higher temperature to see if any damage occurs.

100% Hydrogen Test Conclusions

The burner air and gas pressure were set in both tests to achieve similar capacity. Comparing firing data results for 100% Hydrogen to natural gas the gas consumption of Hydrogen is nearly 3 times greater than gas. From the emission data the Nox and NO and SO₂ are far greater on the 100% Hydrogen firing when comparing to data from Natural gas test, with the CO₂ greater on gas firing

Following 100% Hydrogen test at Therser, consideration should be given to the supply method of Hydrogen for fully operational test kiln. The required flow rate to run burner at full power rating was 22m³/Hr. Due to pressure inhibition of compressed gas a flow rate of 15m³/Hr could only be achieved

Appendix 6



Draft design of 1,300 °C multipurpose ceramic test kiln

Author: Mick Hughes

Reviewer: Brandon Pilfold

Therser (UK) Ltd
Walley Street,
Burslem,
Stoke on Trent,
Staffordshire,
ST6 2AH, UK

Draft design of 1,300 °C multipurpose ceramic test kiln

Data regarding the firing cycle and product used for the 1,300 °C Hydrogen Test Kiln was taken and used in an in-house ‘thermal requirements’ program to obtain a theoretical value for the amount of energy (Thermal input) needed to meet specification.

The in-house program was used to calculate the amount of energy required when using Natural Gas as a fuel source for the burners as well as having an excess of combustion air (10% by volume) to ensure that all of the Natural Gas fully combusts. (3,335.1 MJ which equates to approximately 99.85 m³ (with a theoretical gas flow rate of 6.5 – 15.5 nm³/hr) when using the Lower Heating Value (LHV) of Natural Gas (33.4 MJ/m³))

Below (Table 1) is the firing cycle for heating up 100kg of product from ambient to the design temperature of 1,300 °C.

| Time (hr) | Temp :rature | |
|-----------|--------------|------|
| | Start | End |
| 1 | 25 | 150 |
| 2 | 150 | 300 |
| 3 | 300 | 450 |
| 4 | 450 | 600 |
| 5 | 600 | 750 |
| 6 | 750 | 900 |
| 7 | 900 | 1050 |
| 8 | 1050 | 1200 |
| 9 | 1200 | 1300 |

Table 1 - Firing Cycle

To achieve an equivalent thermal input when using 100% Hydrogen Gas, along with the continued 10% excess air to ensure complete combustion, it was calculated (using Hydrogens LHV of 10.8 MJ/m³) to be approximately 308.8 m³ of H₂ which is close to 3.1 times the volume of Natural Gas; However, Natural Gas requires an AFR (Air-Fuel Ratio) of 10:1 (11:1 with the excess air) and Hydrogen only requires an AFR of 2.5:1 (2.75:1 with excess air). Taking into account the difference in fuel and air quantities, the total amount of air when using 100% Hydrogen ends up being 25% less than that of using 100% Natural Gas.

Having a reduced amount of air used in combustion means that less energy is wasted trying to heat up waste gases (Mainly nitrogen as it’s the main constituent of air at 79% by volume), this allows for more energy to be used productively when heating as well as a lower amount of total thermal input to achieve the same target temperature.

Upon completion of energy calculations for the waste gas produced by both fuels, it was shown that the combustion products of the Natural gas required about 1.86 MJ/K whereas Hydrogens combustion products only required 1.51 MJ/K, this shows that approximately 19% less energy is required to heat up Hydrogen’s combustion products by the same rate as Natural Gas, this leads to the assumption that

about 19% less Hydrogen (which is approximately 250.8 m³) is required to achieve the same temperature ramp rate of 150 °C/hour. (With a theoretical gas flow rate of 16.4 – 39 nm³/hr)

Once the Hydrogen gas has been fully combusted, it is assumed that the emissions would be as shown below (Table 2) (Values are comparing Natural Gas and Hydrogen Emissions):

| Emission Gas | Fuel Source Total Emissions (Nm ³) | | |
|----------------|--|-----------------------------------|---------------|
| | NG | H2 (For Equivalent Thermal Input) | H2 (19% Less) |
| Nitrogen | 867.722984 | 638.93183 | 518.9654358 |
| Carbon dioxide | 99.8530477 | 0 | 0 |
| Water Vapour | 199.706095 | 308.8048 | 250.8233407 |
| Oxygen | 19.9706095 | 15.44024 | 12.54116703 |

Table 2 - Calculated Emissions

Rough calculations indicate that the emissions will have approximately 30% humidity and will produce just under 187.7kg of water vapour which equates to 0.19 m³ or 187.7L of liquid water. (It should also be stated that NOx and other emissions haven't been taken into account as the concentration of them can widely vary depending on ambient temp, general humidity and other factors). Draft Design of 1300⁰ C Kiln

KILN CHAMBER
1700mm DEEP 1025mm WIDE 1030mm HIGH
KILN DIMENSIONS
3305 LONG 2215 WIDE 2230M HIGH
CERAMIC FIBRE LINED
4 No ESA PYRONICS BURNERS 2.5 THERM RATING
ATEX CONTROLS USED.
HIGH LEVEL GAS DETECTION

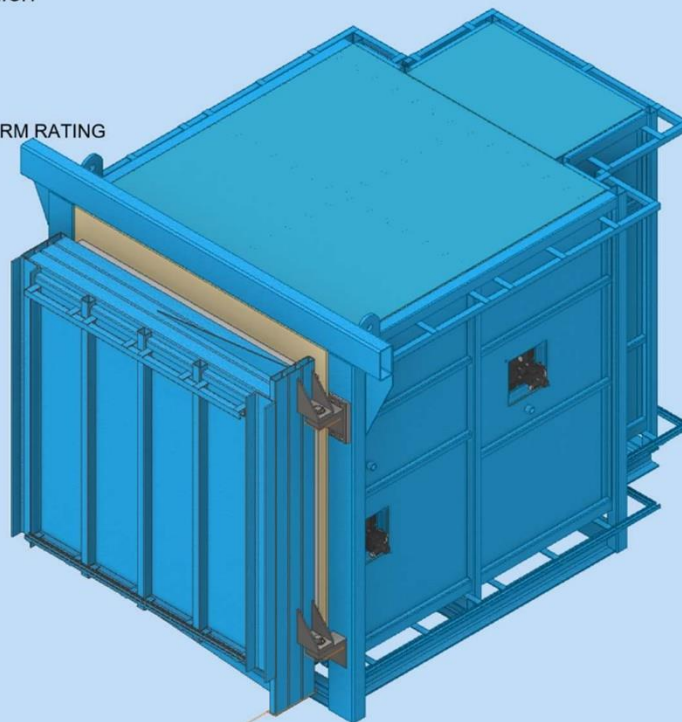

SUMMARY

For the process required of this Kiln to be achieved using 100% Hydrogen gas, it is reasonable to assume that the total volume of Hydrogen will be approximately $250 \text{ m}^3 - 310 \text{ m}^3$ (favouring the lower end of the range) and produce $187.7 \text{ kg} - 231 \text{ kg}$ of water vapour and have a flue humidity near 30% (assuming combustion air is dry).

It should also be noted that the relationship between combustion temperature and flow rate required plays a significant role in a high-temperature firing; During the lower temperature stages, the volume of hydrogen is about 3 times that of natural gas, however, as greater temperatures are reached, the volume of hydrogen needed (compared to natural gas) significantly decreases and slowly becomes a 1:1 ratio before approaching the combustion temperature of natural gas. (Which is $1,960 \text{ }^\circ\text{C}$ in air whereas Hydrogen is at $2,210 \text{ }^\circ\text{C}$)

Following 100% Hydrogen test at Therser, consideration should be given to the supply method of Hydrogen for fully operational test kiln. The required flow rate to run burner at full power rating was $22 \text{ m}^3/\text{Hr}$. Due to pressure inhibition of compressed gas a flow rate of $15 \text{ m}^3/\text{Hr}$ could only be achieved

Required volumetric flow rate of Hydrogen for 1300°C test kiln is $90 \text{ m}^3/\text{Hr}$, using a compressed bottle system is not practical as it requires a large number of banks to achieve both flow and total consumption of Hydrogen during firing cycle.

HIGH LEVEL GAS DETECTION

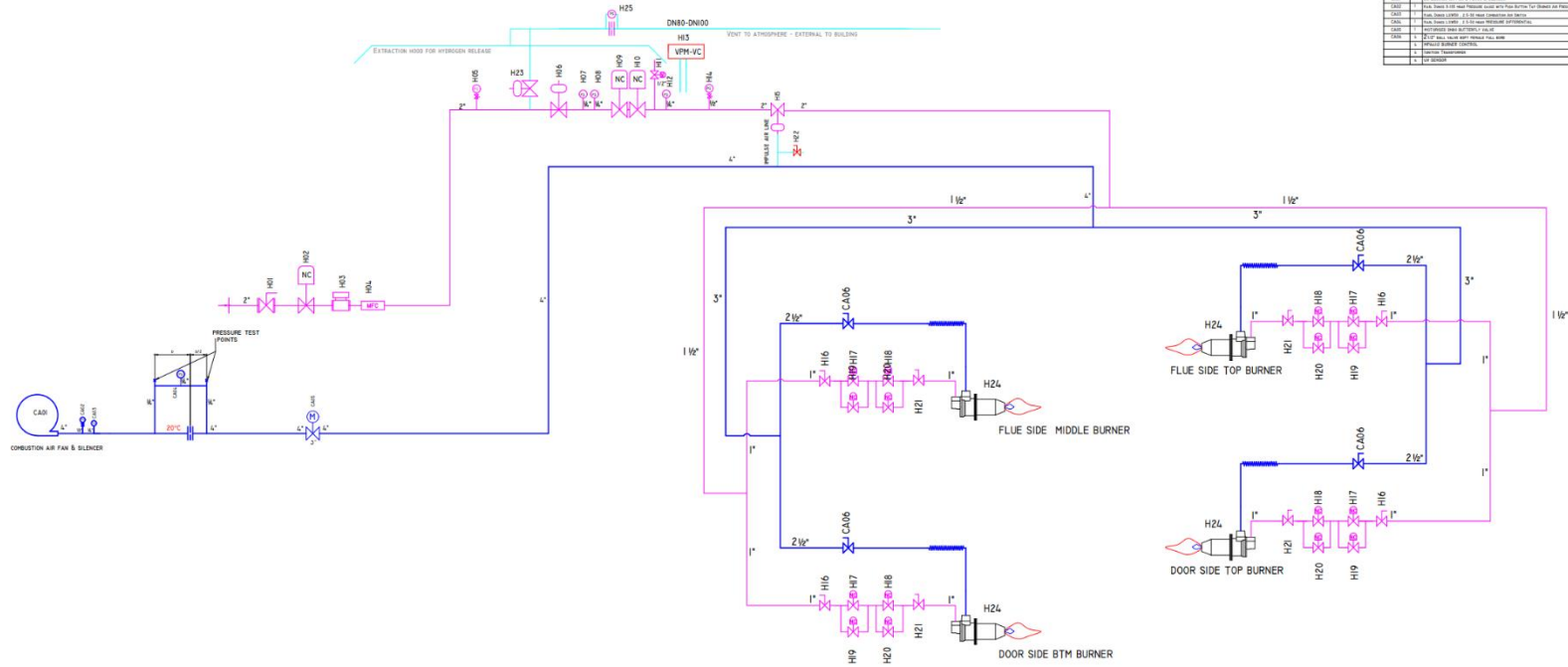

| BILL OF MATERIALS | |
|-------------------|-------------------------|
| ITEM NO. | DESCRIPTION |
| 1 | EXHAUST GAS SAFETY TRAP |
| 2 | 1/2\"/> |
| 3 | 1/2\"/> |
| 4 | 1/2\"/> |
| 5 | 1/2\"/> |
| 6 | 1/2\"/> |
| 7 | 1/2\"/> |
| 8 | 1/2\"/> |
| 9 | 1/2\"/> |
| 10 | 1/2\"/> |
| 11 | 1/2\"/> |
| 12 | 1/2\"/> |
| 13 | 1/2\"/> |
| 14 | 1/2\"/> |
| 15 | 1/2\"/> |
| 16 | 1/2\"/> |
| 17 | 1/2\"/> |
| 18 | 1/2\"/> |
| 19 | 1/2\"/> |
| 20 | 1/2\"/> |
| 21 | 1/2\"/> |
| 22 | 1/2\"/> |
| 23 | 1/2\"/> |
| 24 | 1/2\"/> |
| 25 | 1/2\"/> |
| 26 | 1/2\"/> |
| 27 | 1/2\"/> |
| 28 | 1/2\"/> |
| 29 | 1/2\"/> |
| 30 | 1/2\"/> |
| 31 | 1/2\"/> |
| 32 | 1/2\"/> |
| 33 | 1/2\"/> |
| 34 | 1/2\"/> |
| 35 | 1/2\"/> |
| 36 | 1/2\"/> |
| 37 | 1/2\"/> |
| 38 | 1/2\"/> |
| 39 | 1/2\"/> |
| 40 | 1/2\"/> |
| 41 | 1/2\"/> |
| 42 | 1/2\"/> |
| 43 | 1/2\"/> |
| 44 | 1/2\"/> |
| 45 | 1/2\"/> |
| 46 | 1/2\"/> |
| 47 | 1/2\"/> |
| 48 | 1/2\"/> |
| 49 | 1/2\"/> |
| 50 | 1/2\"/> |
| 51 | 1/2\"/> |
| 52 | 1/2\"/> |
| 53 | 1/2\"/> |
| 54 | 1/2\"/> |
| 55 | 1/2\"/> |
| 56 | 1/2\"/> |
| 57 | 1/2\"/> |
| 58 | 1/2\"/> |
| 59 | 1/2\"/> |
| 60 | 1/2\"/> |
| 61 | 1/2\"/> |
| 62 | 1/2\"/> |
| 63 | 1/2\"/> |
| 64 | 1/2\"/> |
| 65 | 1/2\"/> |
| 66 | 1/2\"/> |
| 67 | 1/2\"/> |
| 68 | 1/2\"/> |
| 69 | 1/2\"/> |
| 70 | 1/2\"/> |
| 71 | 1/2\"/> |
| 72 | 1/2\"/> |
| 73 | 1/2\"/> |
| 74 | 1/2\"/> |
| 75 | 1/2\"/> |
| 76 | 1/2\"/> |
| 77 | 1/2\"/> |
| 78 | 1/2\"/> |
| 79 | 1/2\"/> |
| 80 | 1/2\"/> |
| 81 | 1/2\"/> |
| 82 | 1/2\"/> |
| 83 | 1/2\"/> |
| 84 | 1/2\"/> |
| 85 | 1/2\"/> |
| 86 | 1/2\"/> |
| 87 | 1/2\"/> |
| 88 | 1/2\"/> |
| 89 | 1/2\"/> |
| 90 | 1/2\"/> |
| 91 | 1/2\"/> |
| 92 | 1/2\"/> |
| 93 | 1/2\"/> |
| 94 | 1/2\"/> |
| 95 | 1/2\"/> |
| 96 | 1/2\"/> |
| 97 | 1/2\"/> |
| 98 | 1/2\"/> |
| 99 | 1/2\"/> |
| 100 | 1/2\"/> |



© This drawing is sent by THERSER (UK) LTD and remains their sole property as well as the Copyright therein. It is not to be shown to anyone outside the recipient's company or copied without prior consent. It is to be returned on demand unless otherwise agreed.
 TITLE: DRAFT COMBUSTION DESIGN 1300 Deg HYD TEST KILN
 CUSTOMER: IHA PROJECT

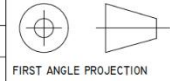

DO NOT SCALE
IF IN DOUBT - ASK
 ALL DIMENSIONS IN MILLIMETRES
 UNLESS STATED OTHERWISE.
 REMOVE ALL BURRS, SHARP EDGES AND CORNERS.

(THERMAL SERVICE & ENGINEERING)
 WALLLEY STREET, BURSLEM,
 STOKE ON TRENT
 STAFFS
 UK ST6-2AH.

| | | | |
|---------------|-------------|----------------|-----------------|
| DRAWN BY:- | MICK HUGHES | DATE | DEC 2022 |
| CHECKED BY:- | | SCALE | NTS |
| APPROVED BY:- | | DRAWING NUMBER | TS11-2888-16-10 |
| | | REV | A |

Appendix 7



Draft design of modify existing 20% hydrogen kiln (1,750 °C)

Author: Mick Hughes

Reviewer: Brandon Pilfold

Therser (UK) Ltd
Walley Street,
Burslem,
Stoke on Trent,
Staffordshire,
ST6 2AH, UK

Draft design of modify existing 20% hydrogen kiln (1,750 °C)

Data regarding the firing cycle and product used for the 1,750 °C Hydrogen Test Kiln was taken and used in an in-house 'thermal requirements' program to obtain a theoretical value for the amount of energy (Thermal input) needed to meet specification.

The in-house program was used to calculate the amount of energy required when using Natural Gas as a fuel source for the burners as well as having an excess of combustion air (10% by volume) to ensure that all of the Natural Gas fully combusts. (11,605 MJ which equates to approximately 347.5 m³ (with a theoretical gas flow rate of 20 – 67 nm³/hr) when using the Lower Heating Value (LHV) of Natural Gas (33.4 MJ/m³))

Below (Table 1) is the firing cycle for heating up 100kg of product from ambient to the design temperature of 1,750 °C.

| Time (hr) | Temperature | |
|-----------|-------------|------|
| | Start | End |
| 1 | 20 | 200 |
| 2 | 200 | 380 |
| 3 | 380 | 560 |
| 4 | 560 | 740 |
| 5 | 740 | 920 |
| 6 | 920 | 1100 |
| 7 | 1100 | 1280 |
| 8 | 1280 | 1460 |
| 9 | 1460 | 1640 |
| 10 | 1640 | 1750 |

Table 1 - Firing Cycle

To achieve an equivalent thermal input when using 100% Hydrogen Gas, along with the continued 10% excess air to ensure complete combustion, it was calculated (using Hydrogens LHV of 10.8 MJ/m³) to be about 978.2 m³ of H₂ which is approximately 3.1 times the volume of Natural Gas; However, Natural Gas requires an AFR (Air-Fuel Ratio) of 10:1 (11:1 with the excess air) and Hydrogen only requires an AFR of 2.5:1 (2.75:1 with excess air). Taking into account the difference in fuel and air quantities, the total amount of air when using 100% Hydrogen ends up being 25% less than that of using 100% Natural Gas.

Having a reduced amount of air used in combustion means that less energy is wasted trying to heat up waste gases (Mainly nitrogen as it's the main constituent of air at 79% by volume), this allows for more energy to be used productively when heating as well as a lower amount of total thermal input to achieve the same target temperature.

Upon completion of energy calculations for the waste gas produced by both fuels, it was shown that the combustion products of the Natural gas required about 5.88 MJ/K where as Hydrogens combustion products

only required 4.78 MJ/K, this shows that approximately 19% less energy is required to heat up Hydrogen’s combustion products by the same rate as Natural Gas, this leads to the assumption that about 19% less Hydrogen (which is approximately 800 m³) is required to achieve the same temperature ramp rate of 180 °C/hour. (With a theoretical gas flow rate of 50 – 170 nm³/hr)

Once the Hydrogen gas has been fully combusted, it is assumed that the emissions would be as shown below (Table 2) (Values are comparing Natural Gas and Hydrogen Emissions):

| Emission Gas | Fuel Source Total Emissions (Nm ³) | | |
|----------------|--|-----------------------------------|---------------|
| | NG | H2 (For Equivalent Thermal Input) | H2 (19% Less) |
| Nitrogen | 2748.647 | 2023.9156 | 1643.903428 |
| Carbon dioxide | 316.3 | 0 | 0 |
| Water Vapour | 632.6 | 978.18704 | 794.521795 |
| Oxygen | 63.26 | 48.909352 | 39.72608975 |

Table 2 - Calculated Emissions

Rough calculations indicate that the emissions will have approximately 30% humidity and will produce just under 600kg of water vapour which equates to 0.6 m³ or 600L of liquid water. (It should also be stated that NOx and other emissions haven’t been taken into account as the concentration of them can widely vary depending on ambient temp, general humidity and other factors). Draft Design of 1750⁰ C Kiln



Design Intent

The existing natural gas train and 20% Hydrogen train will remain. A new 4” NB stainless steel gas train designed to take 100% Hydrogen flow will be installed with input downstream of combined flow. Hydrogen rated and ATEX rated controls will be used and existing burner flame failure control. Extraction hood with

vent will be installed to vent any leakage and high level gas detectors will be installed. If leakage is detected gas supply will be switched off automatically.

The existing 7 Therm Burners will be used as the manufacturer has informed they are suitable for 100% Hydrogen combustion. Burner pressure settings will be set to suit gas used. The existing refractory hot face lining is suitable for temperatures to 1800⁰ C. The refractory around the burner quarl will have to be modified to give a surround of the hot face brickwork, as it will see high temperature. A stream of air will be supplied to surround the quarl to cool.

Combustion air fan will be upgraded and will be VSD controlled.

System will have the flexibility to run 100% Natural Gas, 80%-20% Gas and Hydrogen, 100% Hydrogen and 60%-40% Hydrogen Gas mix.

Existing heat exchanger will still be used to recuperate hot air where required.

SUMMARY

For the process required of this Kiln to be achieved using 100% Hydrogen gas, it is reasonable to assume that the total volume of Hydrogen will be approximately 800 m³ - 978.2 m³ (favouring the lower end of the range) and produce 600 – 730kg of water vapour and have a flue humidity near 30% (assuming combustion air is dry).

It should also be noted that the relationship between combustion temperature and flow rate required plays a significant role in a high-temperature firing; During the lower temperature stages, the volume of hydrogen is about 3 times that of natural gas, however, as greater temperatures are reached, the volume of hydrogen needed (compared to natural gas) significantly decreases and slowly becomes a 1:1 ratio before approaching the combustion temperature of natural gas. (Which is 1,960 °C in air whereas Hydrogen is at 2,210 °C)

Following 100% Hydrogen test at Therser, consideration should be given to the supply method of Hydrogen for fully operational test kiln. The required flow rate to run burner at full power rating was 22m³/Hr. Due to pressure inhibition of compressed gas a flow rate of 15m³/Hr could only be achieved

Required volumetric flow rate of Hydrogen for 1750⁰ C test kiln is 170 nm³/Hr, using a compressed bottle system is not practical as it requires a large number of banks to achieve both flow and total consumption of Hydrogen during firing cycle.

HIGH LEVEL GAS DETECTION

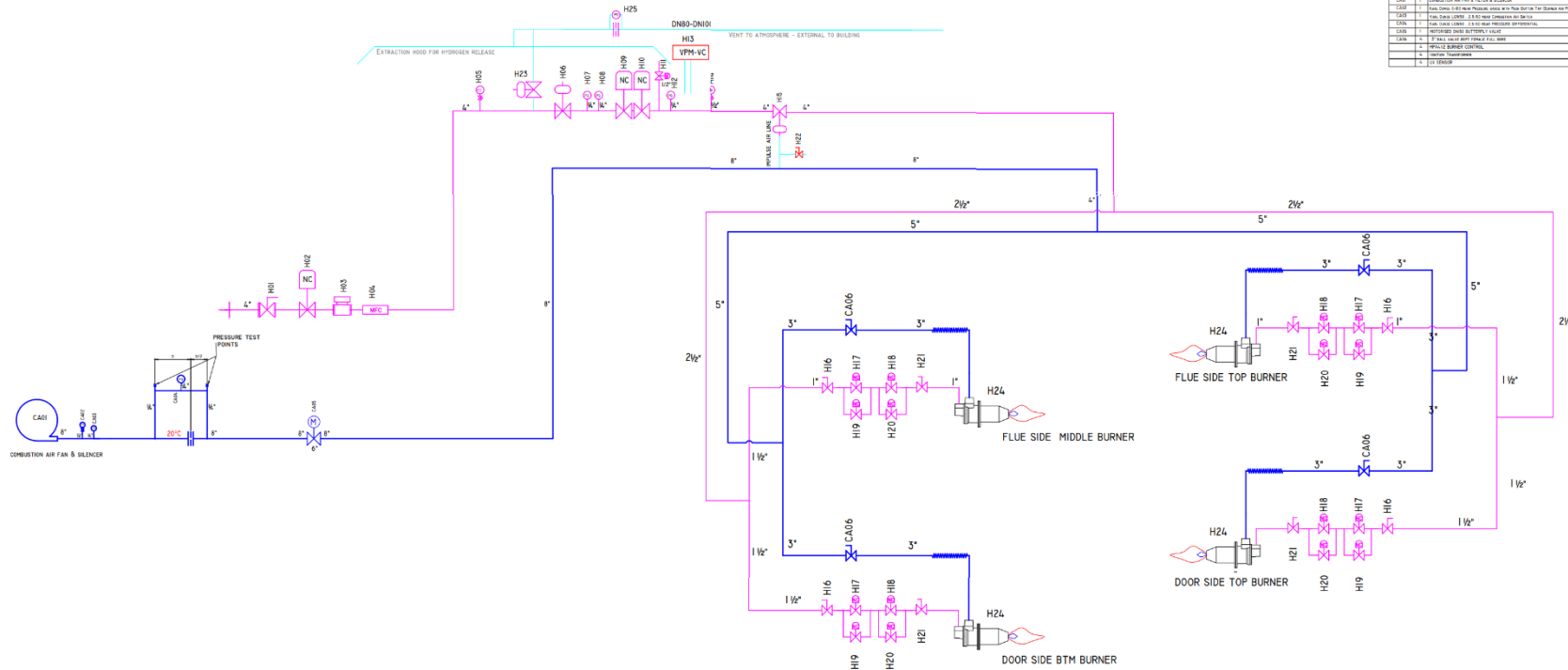

| ITEM NO. | QTY | DESCRIPTION | UNIT | REF. |
|----------|-----|---------------------------------------|------|------|
| 1 | 1 | HYDROGEN GAS SAFETY TRAP | | |
| 2 | 1 | 1/2" NPT VALVE FOR GAS | | |
| 3 | 1 | 1/2" NPT 150# STEEL BALL VALVE - 150# | | |
| 4 | 1 | 1/2" NPT 150# STEEL BALL VALVE - 150# | | |
| 5 | 1 | 1/2" NPT 150# STEEL BALL VALVE - 150# | | |
| 6 | 1 | 1/2" NPT 150# STEEL BALL VALVE - 150# | | |
| 7 | 1 | 1/2" NPT 150# STEEL BALL VALVE - 150# | | |
| 8 | 1 | 1/2" NPT 150# STEEL BALL VALVE - 150# | | |
| 9 | 1 | 1/2" NPT 150# STEEL BALL VALVE - 150# | | |
| 10 | 1 | 1/2" NPT 150# STEEL BALL VALVE - 150# | | |
| 11 | 1 | 1/2" NPT 150# STEEL BALL VALVE - 150# | | |
| 12 | 1 | 1/2" NPT 150# STEEL BALL VALVE - 150# | | |
| 13 | 1 | 1/2" NPT 150# STEEL BALL VALVE - 150# | | |
| 14 | 1 | 1/2" NPT 150# STEEL BALL VALVE - 150# | | |
| 15 | 1 | 1/2" NPT 150# STEEL BALL VALVE - 150# | | |
| 16 | 1 | 1/2" NPT 150# STEEL BALL VALVE - 150# | | |
| 17 | 1 | 1/2" NPT 150# STEEL BALL VALVE - 150# | | |
| 18 | 1 | 1/2" NPT 150# STEEL BALL VALVE - 150# | | |
| 19 | 1 | 1/2" NPT 150# STEEL BALL VALVE - 150# | | |
| 20 | 1 | 1/2" NPT 150# STEEL BALL VALVE - 150# | | |
| 21 | 1 | 1/2" NPT 150# STEEL BALL VALVE - 150# | | |
| 22 | 1 | 1/2" NPT 150# STEEL BALL VALVE - 150# | | |
| 23 | 1 | 1/2" NPT 150# STEEL BALL VALVE - 150# | | |
| 24 | 1 | 1/2" NPT 150# STEEL BALL VALVE - 150# | | |
| 25 | 1 | 1/2" NPT 150# STEEL BALL VALVE - 150# | | |
| 26 | 1 | 1/2" NPT 150# STEEL BALL VALVE - 150# | | |
| 27 | 1 | 1/2" NPT 150# STEEL BALL VALVE - 150# | | |
| 28 | 1 | 1/2" NPT 150# STEEL BALL VALVE - 150# | | |
| 29 | 1 | 1/2" NPT 150# STEEL BALL VALVE - 150# | | |
| 30 | 1 | 1/2" NPT 150# STEEL BALL VALVE - 150# | | |
| 31 | 1 | 1/2" NPT 150# STEEL BALL VALVE - 150# | | |
| 32 | 1 | 1/2" NPT 150# STEEL BALL VALVE - 150# | | |
| 33 | 1 | 1/2" NPT 150# STEEL BALL VALVE - 150# | | |
| 34 | 1 | 1/2" NPT 150# STEEL BALL VALVE - 150# | | |
| 35 | 1 | 1/2" NPT 150# STEEL BALL VALVE - 150# | | |
| 36 | 1 | 1/2" NPT 150# STEEL BALL VALVE - 150# | | |
| 37 | 1 | 1/2" NPT 150# STEEL BALL VALVE - 150# | | |
| 38 | 1 | 1/2" NPT 150# STEEL BALL VALVE - 150# | | |
| 39 | 1 | 1/2" NPT 150# STEEL BALL VALVE - 150# | | |
| 40 | 1 | 1/2" NPT 150# STEEL BALL VALVE - 150# | | |
| 41 | 1 | 1/2" NPT 150# STEEL BALL VALVE - 150# | | |
| 42 | 1 | 1/2" NPT 150# STEEL BALL VALVE - 150# | | |
| 43 | 1 | 1/2" NPT 150# STEEL BALL VALVE - 150# | | |
| 44 | 1 | 1/2" NPT 150# STEEL BALL VALVE - 150# | | |
| 45 | 1 | 1/2" NPT 150# STEEL BALL VALVE - 150# | | |
| 46 | 1 | 1/2" NPT 150# STEEL BALL VALVE - 150# | | |
| 47 | 1 | 1/2" NPT 150# STEEL BALL VALVE - 150# | | |
| 48 | 1 | 1/2" NPT 150# STEEL BALL VALVE - 150# | | |
| 49 | 1 | 1/2" NPT 150# STEEL BALL VALVE - 150# | | |
| 50 | 1 | 1/2" NPT 150# STEEL BALL VALVE - 150# | | |



© This drawing is lent by THERSER (UK) LTD and remains their sole property. It is not to be shown to anyone outside the recipient's company or copied without prior consent. It is to be returned on demand unless otherwise agreed.

TITLE: DRAFT DESIGN RETRO FIT EXISTING HIGH TEMP KILN

CUSTOMER: IMA PROJECT

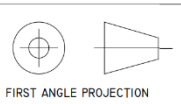

DO NOT SCALE IF IN DOUBT - ASK

ALL DIMENSIONS IN MILLIMETRES UNLESS STATED OTHERWISE. REMOVE ALL BURRS, SHARP EDGES AND CORNERS.

(THERMAL SERVICE & ENGINEERING)
WALLEY STREET, BURSLEM,
STOKE ON TRENT
STAFFS
UK ST6-2AH.

| | | | |
|--------------|-------------|-----------------|-----------------|
| DRAWN BY: | MICK HUGHES | DATE: | DEC 2022 |
| CHECKED BY: | | SCALE: | NTS |
| APPROVED BY: | | DRAWING NUMBER: | TS11-2888-16-11 |
| | | | ISSUE A |

Appendix 18

LUCIDEON

insight creating advantage

Project Title: Literature Review into the Use of Hydrogen as an Alternative Fuel for Ceramic Manufacturing Processes

Client: Centre for Process Innovation Ltd
Wilton Centre
Wilton
Redcar
Teesside
TS10 4RF

For the Attention of: Mr David Brown

Author(s): Dr Aminat Bolarinwa

Report Date: 29 November, 2022

Work Location: Lucideon UK



Mr Chris Thompson
**Consultancy Team
Reviewer**



Dr Aminat Bolarinwa
**Consultancy Team
Project Manager**

This report is issued in accordance with the Conditions of Business of Lucideon Limited and relates only to the sample(s) tested. No responsibility is taken for the accuracy of the sampling unless this is done under our own supervision. This report shall not be reproduced in part without the written approval of Lucideon Limited, nor used in any way as to lead to misrepresentation of the results or their implications.

Lucideon is the trading name of Lucideon Limited. Registered in England No. 1960455.

Lucideon Limited
Queens Road, Penkhull
Stoke-on-Trent
Staffordshire ST4 7LQ

T +44 (0)1782 764428
enquiries@lucideon.com
www.lucideon.com

SUMMARY

Hydrogen is of immense importance as an alternative fuel for use in manufacturing and processing industries. The use of hydrogen as an alternative fuel will help combat the effect of climate change by reducing carbon dioxide emissions, which is a product of burning natural gas. Hydrogen is a light molecule whose combustion by-product is water. Hydrogen has a high adiabatic temperature, which results in increased nitrogen oxide emissions, and it also has heating value, which means that higher volumetric flowrates are required for firing as compared to other fuels.

Hydrogen has been used as an alternative fuel for energy production in a few industries such as oil refineries and steel making industries. There is very limited information available in literature on the efficacy of hydrogen as a fuel for the sintering of ceramic materials and parts. This includes information on the sintering profile in the furnace when hydrogen is burnt as fuel and if there is any resulting effect on the physical, chemical, and mechanical characteristics of ceramics.

Work needs to be carried out to investigate and overcome the challenges associated with the use of hydrogen as an alternative fuel. These challenges include:

- Burner type for burning hydrogen.
- Higher flame temperature, increased formation of NO_x.
- Effect of moisture content (product of burning hydrogen) on the processing product (ceramics).
- Effect on refractory material – investigate effect of hydrogen and moisture content.

The burner to be used in the furnace when burning hydrogen should be specifically designed with material that is able to withstand high temperatures and accommodate high volumetric flowrates associated with hydrogen.

As the by-product of hydrogen is water vapour, its effect on the kiln refractory and the ceramic product to be fired in the furnace must be investigated.

1 INTRODUCTION

In the UK, 4.2 million tonnes of ceramic products were produced in 2014, and although there has been some decline in the corresponding years, the ceramics sector has been slowly recovering. The decline has not affected the technical ceramics market, which has seen revenue increase by more than 30% when compared to 2000.

Natural gas is used to produce 84% of the energy used by the brick making sector in the UK with the rest made up of 13% electricity, 2% oil and 1% coal. The brick making sector is the eighth largest industrial sector in the UK with regards to carbon dioxide (CO₂) emissions.

There has been a drive in seeking alternative fuel for use in industries such as manufacturing and energy production as well as for domestic use. According to Seth Dunn (Dunn, 2002) there are three major factors driving the need for new (alternative) and next generation fuel, which includes: energy security, pollution, and climate change. In terms of climate change, successive governments have introduced policies to limit reliance on fossil fuels, which will then reduce CO₂ emissions.

Hydrogen (H₂) is of immense importance as an alternative fuel source as it offers opportunities for decarbonisation. H₂ can substitute fossil fuel use in production. The United States Department of Energy (DOE) also has significant interest and given resources to the use of H₂ as an alternative industrial fuel source because water is the product when combusted and it generates little or no CO₂ (environmental/climate friendly) (Hemrick, n.d.).

H₂ has been used extensively in the past as a fuel gas in the UK and in blends with natural gas in Singapore and across Europe, and further work is being undertaken to use it more widely in the UK, domestically and across manufacturing and processing industries. Oil refineries, chemicals and steel making industries are among the sectors that have successfully used by-product H₂ as fuel gas (Progressive Energy Ltd, 2017).

This report focuses on the scientific literature available on the effect of H₂ as a fuel gas in the production of ceramic materials. Although some information is available on the effect of burning H₂ on burner manufacture there is very little information available on its effect on the colour, physical and chemical properties of ceramic products. This information can be obtained via sintering/firing trials of ceramic material using H₂ as fuel.

2 HYDROGEN PRODUCTION

Hydrogen (H₂) is one of the most abundant elements, but it is hard to find it as a standalone element. It is usually found bound with oxygen (O₂) in water, and in combination with carbon in hydrocarbons and other forms of life such as animals and plants. Once it is extracted and separated, H₂ is odourless, tasteless, and non-poisonous. When burned in an external combustion engine it produces almost zero exhaust and the only by-product is water (Johnston et al., 2005). H₂ can be generated from a variety of energy sources and production processes (Figure 1). Some of these energy sources include gasoline, natural gas, methanol, solar and wind (Johnston et al., 2005). Hydrogen currently accounts for a modest share of the global energy mix. Hydrogen is currently produced from fossil fuels,

e.g., natural gas or coal. Coal can be reformed to produce hydrogen through gasification.

Another way by which hydrogen is produced is a process known as steam methane reforming (SMR; methane used) and electrolysis (non-renewable electricity consumed). Currently, SMR is the most common and least expensive way to produce H₂ (Dunn, 2002). It involves heating of methane in a catalytic reactor, which strips away hydrogen atoms and steam is added to free up more hydrogen.

| Types of Hydrogen | Production Process and Energy Source |
|-------------------|--|
| Green | <ul style="list-style-type: none">•Pyrolysis process•Energy source: solar, wind hydro |
| Brown | <ul style="list-style-type: none">•Gasification of brown coal•Considerable amount of CO₂ produced |
| Grey | <ul style="list-style-type: none">•Steam methane reforming•Autothermal reforming•More than 70% of the global hydrogen |
| Blue | <ul style="list-style-type: none">•Carbon capture, utilisation and sequestration•It is carried out in demonstration plants, yet to be scaled up |
| Turquoise | <ul style="list-style-type: none">•Molten metal pyrolysis technology•Methan or natural gas to decompose into solid carbon and hydrogen gas |
| Pink | <ul style="list-style-type: none">•Electrolysis•Nuclear power, biofuels and biogas |
| Yellow | <ul style="list-style-type: none">•Electrolysis•Mixed source of electricitty |

Figure 1 - Different types of hydrogen based on the energy source and production process. The sustainability of the hydrogen production process increases as you go up the table (from yellow to green). Table adapted from (Rasul et al., 2022).

These processes produce carbon emissions NOx and particulate matter. For hydrogen to contribute to climate neutrality its production must become fully decarbonised. One way to achieve it, and which also has low economic impact due to the abundance of the raw material, is the dissociation of water into oxygen and hydrogen. By 2030 The EU expects that hydrolysers (devices which split water into hydrogen and oxygen) will reach technological and financial maturity.

3 CHARACTERISTICS OF HYDROGEN AND ITS EFFECTS FOR USE AS A FUEL

3.1 Key Combustion Characteristics of Hydrogen

Table 1 – Combustion Properties of Hydrogen in Comparison to Methane (Progressive Energy Ltd, 2017)

| Property | Unit | Methane | Hydrogen |
|--|-------------------|------------|------------|
| Density* | Kg/m ³ | 0.68 | 0.09 |
| Relative Density (to dry air) | Kg/m ³ | 0.55 | 0.07 |
| Calorific Value (higher heating value) | MJ/kg | 55.5 | 141.8 |
| Wobbe Number | MJ/m ³ | 37.7 | 12.1 |
| | MJ/m ³ | 50.7 | 45.9 |
| Flammability Range | % Vol | 4.4 – 15.0 | 4.0 – 75.0 |
| Laminar burning velocity | m/s | 0.4 | 3.1 |
| Auto-ignition temperature | °C | 600 | 560 |
| Adiabatic Flame Temperature in Air** | °C | 1,960 | 2,210 |

* At 15°C, atmospheric pressure and dry basis

** These figures depend upon the assumed combustion air temperature

As hydrogen is a light molecule, it has a high heating value on a mass basis and low heating value on a volume basis. Therefore, higher volumetric flow rates (higher fuel pressures) of hydrogen are required for firing as compared to other common fuels (Hemrick, n.d.).

3.2 Potential for Hydrogen Use

Hydrogen might be used as fuel in furnaces, kilns, boilers, gas turbines and process heaters. The use of hydrogen in each of these technologies will present unique challenges. These challenges include:

- Burner type for burning hydrogen.
- Higher flame temperature, increased formation of NO_x.
- Effect of moisture content (product of burning hydrogen) on the processing product (ceramics).
- Effect on refractory material – investigate effect of hydrogen and moisture content.

The technical report produced by progressive energy Ltd (Progressive Energy Ltd, 2017) noted from their engagement with brick making and ceramics manufacturing industries that the burners currently installed on the kilns could probably tolerate 10% hydrogen without modification. As the percentage of hydrogen gas in the natural gas fuel is increased or if 100% hydrogen is used as a fuel, then a new burner will be required.

4 EFFECT OF HYDROGEN FUEL GAS

4.1 Burner Design and Emissions

Hydrogen has a higher upper flammability range as compared to methane (Table 1), which means that hydrogen can be ignited over a greater range of compositions in air than methane. When the upper flammability level is taken into consideration along with the laminar burning velocity care must be taken to design a suitable burner and achieve flame stability to avoid flashbacks. The flame temperature for hydrogen as shown in Table 1 is also higher than that of methane. This can lead to increased levels of NO_x during combustion with air. When the high adiabatic flame temperature is combined with the potential change in flame profile, it is important that the materials used in the burner construction is suitable for high temperatures (Progressive Energy Ltd, 2017).

The radiation heat transfer from the flame produced by hydrogen fuel will also be higher than the volume flow rate of combustion as compared to more traditional fuels.

Hydrogen, when burnt in air, will produce water (Equation 1), which may result in the presence of water vapour the furnace atmosphere. The effect of the moisture content on the refractory material as well as the ceramic products fired in the kilns/furnaces will have to be investigated.

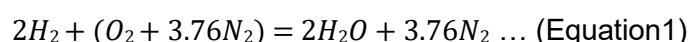

Due to the increased adiabatic temperature and radiation heat transfer associated with hydrogen fuels, careful considerations must be given to the materials from which the burners are made to ensure proper and safe operation. The steel and refractory material used in the construction of the burners must be able to withstand the elevated temperatures (Guarco et al., n.d.). The steel used in the burners to fire H₂ should also not be susceptible to hydrogen embrittlement and high temperature hydrogen attack. These

can prematurely degrade the steel leading to failure of the burner parts . Burners that are not designed specifically for H₂ firing are susceptible to flashbacks. Flashbacks occur when the speed of the gas exiting the burner nozzle is slower than the flame speed (Guarco et al., n.d.).

4.2 Effect on Internal Furnace Pressure and Radiation Temperature

A study carried out by (Hsu et al., 2014) found that as the percentage of hydrogen in the fuel is increased, less theoretical quantity of air is required for complete combustion. The reduction of gas volume in the furnace leads to lower internal furnace pressure, so the hot gas in the furnace rises at an increased speed.

The rising speed of the hot gas reduces its residence time in the furnace leading to insufficient heat exchange.

Hsu et al (Hsu et al., 2014) also found the furnace radiation temperature to decrease but the furnace convection zone temperature increased.

The rising of the hot gas with less residence time in the furnace as well as the reduction in the radiation zone temperature could require that more sintering time is required when firing ceramic materials in the furnace.

To counter these detrimental effects, the flowrate of fresh air into the furnace can be controlled to increase furnace internal pressure as well as adjusting the flue gas baffle angle to slow down the uprising of the hot gas (Hsu et al., 2014).

4.3 Effect Hydrogen Fuel on Refractory Materials

Accelerated wear as well as discolouration of the refractory lining surface was discovered in parts of the kiln after use of hydrogen. The discolouration of the refractory lining is associated with the presence of chloride in the waste hydrogen gas which was used as fuel (Hemrick, n.d.). Additionally, hydrogen exhibits high flame speeds and relatively high adiabatic flame temperatures compared to other fuels, leading to higher radiation of heat transfer from the flame and reduced combustion product volume flow rates. This process has been shown in many cases to result in higher temperatures, longer heating resident times, increased NO_x levels, and different heat distributions within furnaces, causing more extreme conditions for burner and correspondingly furnace components. The residence time for the hot gasses in the furnace is reduced as the hydrogen use is increased (smaller molecule). The volume and temperature of the flue gas is reduced, which leads to a reduction in internal furnace pressure. Increased use of hydrogen also leads to increased emission of NO_x and increased presence of water in the furnace. This leads to concern that an acid compound is formed in the furnace. This could have a deleterious effect on the refractory ceramic lining material performance such as accelerated wear, chemical attack, and overheating (Hemrick, n.d.). For example, it was shown that reactions occur between reducing gas (such as hydrogen) and stable oxides like silica, alumina, and zirconia that make up many refractory ceramic lining materials. This reaction produces gaseous suboxides and water vapor that can be carried downstream to interact with furnace components and the product being processed. Additionally, such reduction of these oxides was shown to accelerate refractory corrosion and decreased refractory strength (Hamling, 2002).

4.3.1 Hydrogen Atmospheres and Kiln Furniture

In hydrogen gas atmospheres, silica (commonly used for its high temperature stability and increased mechanical strength) is attacked, which causes the silica to dissociate and volatilise. The result of such an outcome is premature failure of the refractory. Alumina is typically used where reduction by aggressive furnace atmospheres is encountered, as with the case in hydrogen atmosphere. However, the effect of hydrogen gas on alumina is not generally known. Following an experiment carried out and reported in literature (Hamling, 2002), alumina was found to exhibit the lower mass loss when fired in hydrogen as compared to silica. Rank et. al.(Rank et al., 2002) also reported mass loss in refractory materials with different alumina to silica ratio when fired in a hydrogen atmosphere at 1500°C for over 192 hours. The mass loss of the refractory material increased with an increase in the amount of silica, sintering time and temperature.

As expected, the cold compressive strength of the refractory bricks decreased in some cases by up to 40% as a function of mass loss (Rank et al., 2002).

5 CONCLUSIONS

There was very little information in literature on the effect of using hydrogen as fuel when sintering ceramic materials. It is therefore not understood how the firing profile in the furnace will differ and its subsequent effect on sintering time and ceramic material properties. As hydrogen is a small molecule; higher volumetric flow rate is required in comparison to natural gas. The high adiabatic temperature of hydrogen fuel also requires that the material from which the burner is manufactured can withstand high temperature. Other effects of using hydrogen as fuel that has been reported include:

- I. Reduced internal furnace pressure which leads to reduced residence time of hot gases. Inefficient heat exchange.
- II. Increased levels of NO_x gases
- III. Higher heat release rate which can lead to more heat at the front end of the kiln. This will require changes to the process air and other parameters.
- IV. Accelerated wear was also noted in select sections of the kiln when hydrogen is fired.

It has been reported in the literature that no modification will be required in kilns and burners when up to 10% hydrogen is mixed in with natural gas as fuel. Burner modifications are necessary as the amount of hydrogen to be used as fuel is increased.

REFERENCES

- Dunn, S. (2002). Hydrogen futures: toward a sustainable energy system. In *International Journal of Hydrogen Energy* (Vol. 27). www.elsevier.com/locate/ijhydene
- Guarco, J., Langstine, B., & Turner, M. (n.d.). *Practical Considerations for Firing Hydrogen Versus Natural Gas*.
- Hamling, P. (2002). High-Performance Insulation for Hydrogen Sintering. *Ceramic Industry*, 152(7), 28–30.
- Hemrick, J. G. (n.d.). Refractory issues related to the use of hydrogen as an alternative fuel. *American Ceramic Society Bulletin*, 101(2), 23–31.
- Hsu, C. K., Lee, C. L., Wang, C. H., & Jou, C. J. G. (2014). Reduction of energy consumption and pollution emissions for industrial furnace using hydrogen-rich tail gas. *International Journal of Hydrogen Energy*, 39(18), 9675–9680. <https://doi.org/10.1016/j.ijhydene.2014.03.195>
- Johnston, B., Mayo, M. C., & Khare, A. (2005). Hydrogen: The energy source for the 21st century. *Technovation*, 25(6), 569–585. <https://doi.org/10.1016/j.technovation.2003.11.005>
- Progressive Energy Ltd. (2017). *The Liverpool-Manchester Hydrogen Cluster: A Low Cost, Deliverable Project*.
- Rank, J., Melzer, D., Werschky, M., Ullrich, B., & Walter, G. (2002). Behaviour of Refractories in Hydrogenous Atmospheres. *Interceram*, 57(5), 319–232.
- Rasul, M. G., Hazrat, M. A., Sattar, M. A., Jahirul, M. I., & Shearer, M. J. (2022). The future of hydrogen: Challenges on production, storage and applications. In *Energy Conversion and Management* (Vol. 272). Elsevier Ltd. <https://doi.org/10.1016/j.enconman.2022.116326>



Centre for Process Innovation Limited
Wilton Centre, Wilton, Redcar, TS10 4RF, United Kingdom

Copyright © 2022 Centre for Process Innovation Limited trading as CPI. All rights reserved.

