



# Cancellation of certain backdated business rates liabilities

Guidance note





Guidance note for local authorities on  
implementing the cancellation of certain  
backdated business rates liabilities

February 2012  
Department for Communities and Local Government

© Crown copyright, 2012

*Copyright in the typographical arrangement rests with the Crown.*

You may re-use this information (not including logos) free of charge in any format or medium, under the terms of the Open Government Licence. To view this licence, visit <http://www.nationalarchives.gov.uk/doc/open-government-licence/> or write to the Information Policy Team, The National Archives, Kew, London TW9 4DU, or e-mail: [psi@nationalarchives.gsi.gov.uk](mailto:psi@nationalarchives.gsi.gov.uk).

This document/publication is also available on our website at [www.communities.gov.uk](http://www.communities.gov.uk)

Any enquiries regarding this document/publication should be sent to us at:

Department for Communities and Local Government  
Eland House  
Bressenden Place  
London  
SW1E 5DU  
Telephone: 030 3444 0000

February, 2012

ISBN: 978-1-4098-3341-1

# Guidance Note for Local Authorities on Implementing the Cancellation of Certain Backdated Business Rates Liabilities

## Introduction

1. This guidance note has been produced to set out how certain backdated rates liabilities, relating to the 2005 rating list, will be cancelled and to give examples of when the cancellation applies.
2. The purpose of the guidance note is to give assistance to local authorities in implementing the legislation cancelling certain backdated business rates liabilities in respect of the 2005 rating list. The power to cancel these liabilities is contained in the Localism Act 2011. A copy of the Localism Act is available at <http://www.legislation.gov.uk/ukpga/2011/20/contents/enacted>.
3. Users of this guidance note should be aware that this guidance has no legal status and does not supersede the legislation. In the case of any doubt, the legislation will prevail. Authorities and other users of this note should take their own legal advice if they are in any doubt as to the interpretation of the legislation.

## Background

### The “Schedule of Payment” scheme

4. In 2009 the previous Government introduced a scheme referred to as the ‘schedule of payments’ scheme which allows ratepayers that meet certain criteria (as set out under SI 2009/204: The Non-Domestic Rating (Collection and Enforcement) (Local Lists) (Amendment) (England) Regulations 2009) to repay eligible backdated liabilities over a period of eight years. Please refer to the Business Rates Information Letter 2/2009 available at <http://www.communities.gov.uk/archived/general-content/localgovernment/ratesletters2009/>.

### Moratorium on payments under the “Schedule of Payments” Scheme

5. In June 2010, the Government introduced legislation, (SI 2010/1507: The Non-Domestic Rating (Collection and Enforcement) (Local Lists) (Amendment) (England) Regulations 2010), that placed a moratorium on repayments under the schedule of payments scheme until 31 March 2011. Please refer to the Business Rates Information Letter 8/2010 available at <http://www.communities.gov.uk/localgovernment/localgovernmentfinance/businessrates/busratesinformationletters/ratesletters2010/>. The moratorium was extended for the financial year 2011/12 via SI 2011/113: The Non-Domestic Rating (Collection and Enforcement) (Local Lists) (Amendment) (England) Regulations 2011.

### Backdated liabilities not meeting the “Schedule of Payments” Scheme

6. Backdated liabilities that do not meet the “Schedule of Payments” criteria remain payable and should be collected by billing authorities in the usual manner in accordance with the Non-Domestic Rating (Collection and Enforcement) (Local Lists) (England) Regulations 1989.

# Cancellation of Certain Backdated Business Rates Liabilities

## Summary

7. A copy of the regulations enabling the cancellation: The Non-Domestic Rating (Cancellation of Backdated Liabilities) Regulations 2012 (SI 2012: 537) is available at <http://www.legislation.gov.uk/ukxi>.
8. Briefly, the policy is that the cancellation applies to those ratepayers who are liable to pay backdated rates liabilities which meet the “schedule of payments” criteria and who additionally incurred those backdated liabilities as a result of the hereditament being ‘split’ from the assessment of a predecessor hereditament.

## Period of Eligibility

9. The cancellation only applies in respect of certain backdated liabilities and not for ongoing liabilities, which must be discharged in the usual manner. The extent of backdated liability for each qualifying hereditament is limited, in accordance with the “schedule of payments” Regulations (SI 2009 No.204), to the period up to and including the initial alteration date (when a qualifying newly assessed hereditament (the ‘qualifying hereditament’) was added to the rating list).
10. A rates liability accrued after the initial alteration date is classed, for the purposes of identifying the unexpected backdated liability, as ongoing rates. At that point in time, the known occupier receives a demand notice and is “on notice” of the existence of rateable liability.
11. Therefore, a liability for rates on the part of a property which a ratepayer occupies cannot be said to be unexpected after that initial alteration date even if, in hindsight (perhaps after the outcome of an appeal), the amount owed is reduced due to changes in the physical size of a property to accurately reflect the rateable occupation and/or rateable value.
12. Where such an occurrence occurs a subsequent change to a ‘qualifying hereditament’ which could involve its complete deletion and replacement with a further ‘new hereditament’, may mean that the ‘new’ hereditament is not entitled to the cancellation (if, for example, the ‘new hereditament’ is added to the rating list after 31 March 2010). Each newly listed hereditament needs to be assessed in its own right to see if it meets the cancellation criteria. Please see example 8.
13. However, even if a ‘new hereditament’, (that replaces a now deleted ‘qualifying hereditament’,) does not in its own right meet the criteria, then, in the same way that this does not make the existing “schedule of payments” for the ‘qualifying property’ invalid (in accordance with SI 2009/204), it will not affect the extent of the backdated rates liability subject for cancellation. This is subject to the requirement that the initial alteration is a property being “split” from the assessment of a predecessor hereditament.
14. The amount of backdated liability up to the initial alteration date of the original ‘qualifying hereditament’ will still be cancelled and the amount will be “transferred” to the subsequent ‘new property’. The now deleted qualifying hereditament becomes a qualifying predecessor hereditament. Please see example 7. To note, where the rateable value is reduced, the amount of the backdated liability up to the initial alteration date will also reduce.
15. A ratepayer is liable for their ongoing rates bill that accrues from the initial alteration date. This is because once a property is added to the rating list the occupying ratepayer is liable to make ongoing payments towards their ongoing rates liability.

16. There may be instances where there is a disagreement over the assessment of liability. Where an appeal has been made, a ratepayer remains liable for their ongoing rates until/unless an alternative is agreed by the ratepayer and the valuation officer (VO) or is determined by the valuation tribunal.
17. Of course, any subsequent changes that reduce the rates liability may then be backdated. Therefore, if, as a result of an incorrect assessment, a ratepayer has overpaid their ongoing rates from the initial alteration date, this can be credited against the eventual assessment, or they may be entitled to a refund. Current collection and enforcement procedures will continue to apply to ongoing rates liabilities and backdated liabilities outside of the schedule of payment policy.
18. ***Cancellation of liability and the qualifying hereditament and qualifying predecessor hereditament***– The regulations provide that the hereditament currently shown on the rating list is the starting point for assessing any cancellation of liability. So the first matter to consider is whether the hereditament currently shown on the rating list qualifies in itself on its own merits.
19. Where the current hereditament does not qualify on its own merits, a cancellation of liability may apply if a “predecessor hereditament” to the current hereditament would have been a “qualifying hereditament”, had there been no further alterations to it. The qualifying hereditament as it no longer exists becomes a qualifying predecessor hereditament. However, only those ratepayers who were subject to the backdated rates liability on the qualifying predecessor hereditament can have the cancellation “transferred” to their current hereditament shown on the list (see example 8).
20. ***A qualifying hereditament*** –Conditions 4 of the Non-Domestic Rating (Cancellation of Backdated Liabilities) Regulations 2012 (SI 2012: 537) apply to the assessment of the current hereditament shown on the rating list, subject to the hereditament being shown on the list as the result of a “relevant list alteration”.
21. The legislation is limited to those ratepayers facing a significant backdated liability from an alteration to the list being backdated by 33 months or more. So the occupier of a hereditament that generates liability backdated to 1 April 2005 could potentially benefit if the rating list was actually altered on or after 1 January 2008.
22. The effective date for the backdated liability does not need to be 1 April 2005. For example, a hereditament with a rating list alteration date of the 1 January 2009 could be eligible for the cancellation of liability (subject to meeting the other criteria) if the effective date was on or before 1 April 2006. Where the “qualifying period” is less than 33 months the occupier is not entitled to the cancellation of liability as the extent of the backdated assessment is less than 33 months.
23. The policy is that the cancellation does not extend to backdated liability owed by an occupier who previously occupied the predecessor hereditament that has been split into two or more hereditaments, as in these circumstances, the backdated liability cannot be described as unexpected. So only the ratepayer who *was not* liable for rates on the predecessor hereditament that was split is entitled to a cancelled rates liability.
24. Where there has been a series of alterations prior to a hereditament being split, the occupier of a current hereditament who was also liable for rates on any preceding hereditament to the now split hereditament is also not liable for a cancellation. This is because liability for rates on their current hereditament cannot be said to be unexpected if they were also liable for rates on a hereditament that preceded the hereditament that was split and it forms part of their current hereditament (see example 6).

25. **The qualifying predecessor hereditament** – Where a hereditament does not meet the condition 4, conditions 5 of the Non-Domestic Rating (Cancellation of Backdated Liabilities) Regulations 2012 (SI 2012: 537) apply to an assessment of the qualifying predecessor hereditament and occupier in the same way as for the qualifying hereditament.
26. **The relevant list alteration** – Conditions 6 of the Non-Domestic Rating (Cancellation of Backdated Liabilities) Regulations 2012 (SI 2012: 537) set out the circumstances by which an alteration to the rating list is a “relevant list alteration”, subject to meeting conditions set out in the first or second set of conditions as appropriate. The policy is aimed at liability accrued from newly split hereditaments shown in the rating list that are shown in order to correct an inaccuracy to the rating list.
27. The policy is a one off measure to correct unfairness incurred by certain ratepayers during the economic downturn and is restricted to the 2005 rating list and to alterations that occurred on or before the 31 March 2010. A backdated assessment occurring on or after 1 April 2010 would therefore not qualify for a cancellation.
28. The policy does not apply to where a list is updated as a result of an occupier’s proposal or appeal. As in these circumstances, the backdated liability cannot be described as unexpected. Therefore the policy is that the backdated liability should be the result of unilateral action undertaken by the Valuation Office Agency
29. The policy is aimed only at new hereditaments formed as the result of being split from an existing rateable hereditament, where another party was liable for the rates on the predecessor hereditament.
30. A fundamental principle of rating policy is that all non-domestic properties are liable for non domestic rates and should all be assessed consistently to ensure that the burden of contributions to funding local government is shared fairly amongst businesses.
31. The anomaly in this situation is that of an unfairness (due to a combination of circumstances under which certain backdated rates bills were incurred). On reviewing the issue, it was found that only those ratepayers with significant backdated bills, incurred during the economic downturn, resulting from the property they occupy being split from a predecessor hereditament could genuinely and justifiably have found the backdated bills to be unexpected.
32. This is because where hereditaments were rated as part of predecessor hereditaments the occupiers may have been under the misconception that another party, the landlord, was liable for the rates and they were making a contribution to their landlord’s rates through other means, such as rent.
33. The policy does not apply to a hereditament already being in existence that has had its rateable value increased, or two or more existing hereditaments in control of the same ratepayer that are merged into one hereditament, newly built hereditaments or those that were previously exempt but are no longer. In these circumstances, the liability for rates on the hereditament cannot be described as unexpected.
34. **The predecessor hereditament** – a “predecessor hereditament” is a hereditament that is no longer shown on the rating list, because it was deleted by an alteration to the rating list and replaced with a new hereditament, but that earlier hereditament formed part of the later and/or current hereditament.

## Schedule of Payment Scheme vs Cancellation Policy

35. The schedule of payments scheme will continue for those ratepayers who are not eligible for a cancellation of liability. Therefore agreements made under the relevant Regulations will still stand.

## Implementation of Cancellation

36. There will be no application process for the cancellation. In the first instance, local authorities should automatically apply the cancellation to those ratepayers known to meet all the criteria. Legislation will also be amended to allow for information to be added to Demand Notices for the year 2012/13. This will inform ratepayers about the cancellation policy and provide a link to this guidance and examples, and therefore, if applicable, allow them to come forward to the local authority in regards to their eligibility. This keeps the process in line with existing mandatory reliefs.
37. If that occurs the Valuation Office Agency can assist, if a local authority makes a request, and provide information as to whether an individual property was a reconstitution of a predecessor hereditament.
38. However, the cancellation policy criteria does not just relate to the hereditament. In particular, where the occupier of a newly split hereditament was also the occupier of the single hereditament that preceded the split that ratepayer would not be entitled to a cancelled bill (see example 1). It will be the responsibility of the local authority to satisfy themselves that all the necessary criteria relating to the hereditament and the occupier and the rates liability for the waiver has been met before cancelling any backdated liability.

## Process

39. A hereditament and the ratepayer would need to have met the conditions set out in the Non-Domestic Rating (Cancellation of Backdated Liabilities) Regulations 2012 (SI 2012: 537) before its backdated liability is entitled to be cancelled.
40. The process for cancelling the backdated element of bills for those that meet the criteria should follow the same as that applied to mandatory reliefs, such as charity relief; therefore eligible ratepayers will need to have the backdated bills recalculated at 'Rateable Value x Multiplier x 0' and re-billed for each chargeable day that meets the criteria for the cancellation; i.e. each day between the effective date and the alteration date of a qualifying hereditament.
41. As for each chargeable day, the rates liability will become zero and ratepayers that have discharged in full, or some, of the backdated liability that qualifies, will be entitled to a refund/credit.
42. The Department will be amending the NNDR3 forms for 2011/12 to allow for any reduction in rates collected to be reflected in the required payments by authorities into the central rates pool. However, where authorities need to amend in-year payments to reflect cancellations, they should submit the requisite NNDR 2 form through the usual route.



## Q&A about application process

### **Q1. What is defined as the eligible backdated period?**

- A. The backdated period begins with the effective date of the relevant list alteration and ends with the alteration date of the relevant list alteration (the date from which the initial alteration is applied). So, for a hereditament meeting the criteria, which is added to the rating list for the first time on 10 March 2009, with a backdated liability from 1 April 2005, the backdated period eligible for the waiver will be 1 April 2005 to 10 March 2009 inclusive (see example 1).

### **Q2. But what if further changes are made to the property's assessment or if the ratepayer knows that that the initial one is incorrect?**

- A. Even if further changes are made to the assessment of the hereditament, which alter the amount of rates payable, the backdated period for cancellation remains the initial alteration date (so 10 March 2009, in the example above). A ratepayer is liable for their ongoing rates bill that accrues from that initial alteration date.

If a qualifying hereditament is deleted and replaced then the further newly listed hereditament needs to be assessed in its own right to see if it meets the cancellation criteria. If not, then the backdated liability up to the initial alteration date of the replaced qualifying predecessor hereditament would be transferred to the further newly listed hereditament (see example 6).

### **Q3. Ratepayers have not paid what is determined as ongoing rates – can't we just wrap these up into the waiver as backdated?**

- A. No - the cancellation is limited to the backdated liability up to the initial alteration date. Current collection and enforcement procedures will continue to apply to ongoing rates liabilities and backdated liabilities outside of the schedule of payment policy.

### **Q4. We would like to offer ratepayers the option of paying the ongoing liability in instalments; will the Government allow us to contribute less into the pool to help us do this?**

- A. A local authority is legally obliged to make the required contributions to the central rates pool. However, as long as it continues to meet the appropriate payments to the pool, a local authority may collect outside of the prescribed usual manner and come to a separate agreement for the collection of ongoing rates with the ratepayer in accordance with paragraph 7 of the Non-Domestic Rating (Collection and Enforcement) (Local Lists) Regulations 1989 (SI 1989/1058) as amended.

However, it is for each local authority to satisfy itself as to whether it is acting lawfully and in accordance with existing legislation if it decides to enter into a flexible agreement with ratepayers for the collection of ongoing rates liabilities, outside of the usual collection processes in the Non-Domestic Rating (Collection and Enforcement) (Local Lists) Regulations 1989 (SI 1989/1058) as amended. Local authorities must though continue to meet their obligations to make payments of the appropriate amounts to the central rates pool.

## EXAMPLES

43. Please note that all the examples assume that the alteration to the rating list is as a result of independent action by the VOA (properties that are newly identified by notification from the billing authority to, or discovery by, the Valuation Office Agency). This is because the cancellation policy does not apply to where a list is updated as a result of an occupier's proposal or appeal. In these, circumstances, the backdated liability cannot be described as unexpected.
44. The examples provide a guide to how the regulations work in individual circumstances, although the examples provided do not cover every possible circumstance. The term property has been used for hereditament in the following examples.

# Assessment for Waiver Where properties have been reassessed

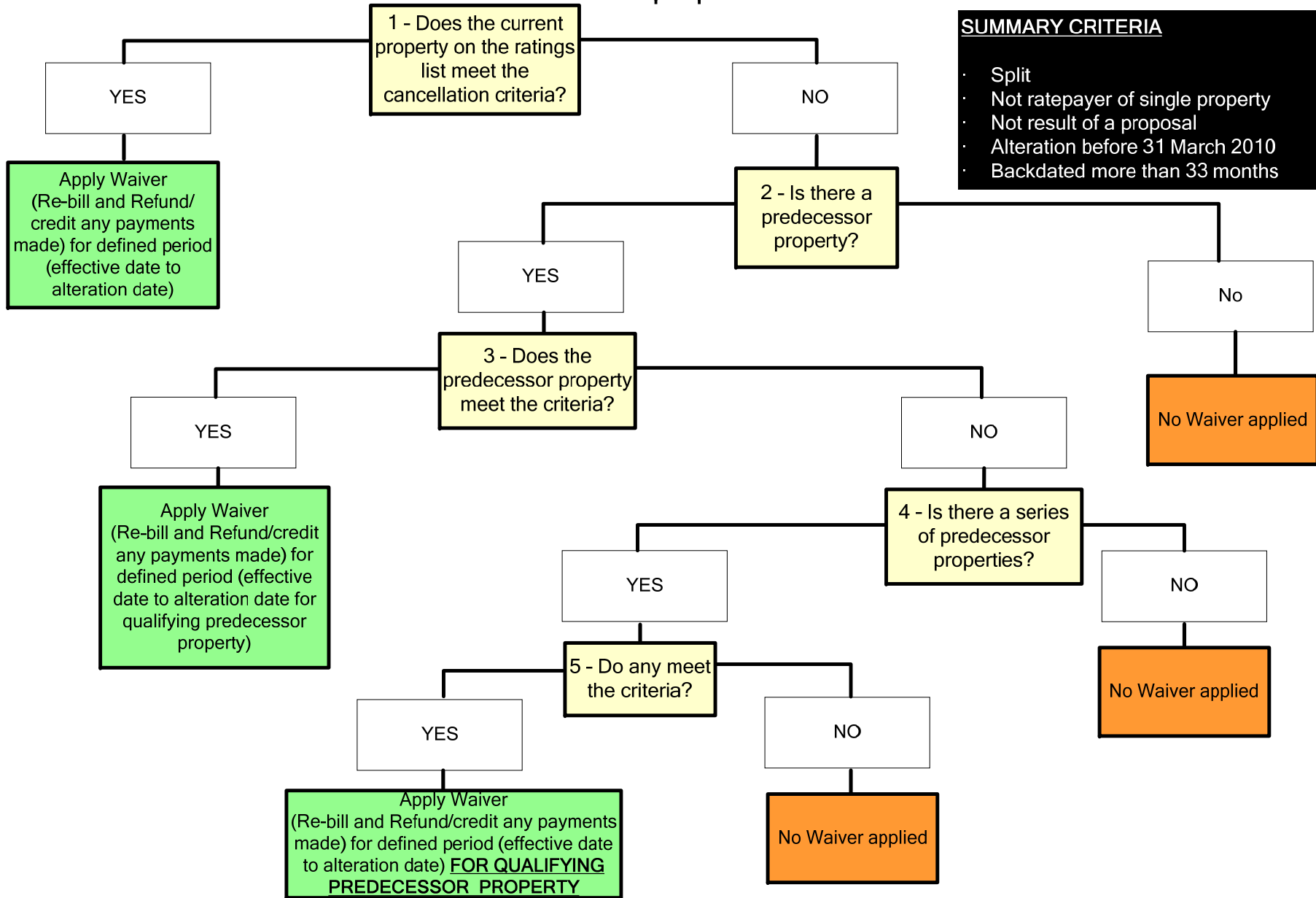

**SUMMARY CRITERIA**

- Split
- Not ratepayer of single property
- Not result of a proposal
- Alteration before 31 March 2010
- Backdated more than 33 months

1 - Does the current property on the ratings list meet the cancellation criteria?

YES

Apply Waiver (Re-bill and Refund/credit any payments made) for defined period (effective date to alteration date)

NO

2 - Is there a predecessor property?

YES

3 - Does the predecessor property meet the criteria?

YES

Apply Waiver (Re-bill and Refund/credit any payments made) for defined period (effective date to alteration date for qualifying predecessor property)

No

No Waiver applied

NO

4 - Is there a series of predecessor properties?

YES

5 - Do any meet the criteria?

YES

Apply Waiver (Re-bill and Refund/credit any payments made) for defined period (effective date to alteration date) **FOR QUALIFYING PREDECESSOR PROPERTY**

NO

No Waiver applied

NO

No Waiver applied

# Simple Splits

In order to be eligible for the waiver: the backdated liability must have been incurred following a property bring split from the rates assessment of another property, prior to 31 March 2010; the backdated liability must be greater than 33 months; and the ratepayer should not have been liable for rates on the predecessor property prior to the split. Where all of the above criteria is met, it will usually represent a simple split, however it is possible that following further changes or appeals there are further alterations etc. Some examples are set out below.

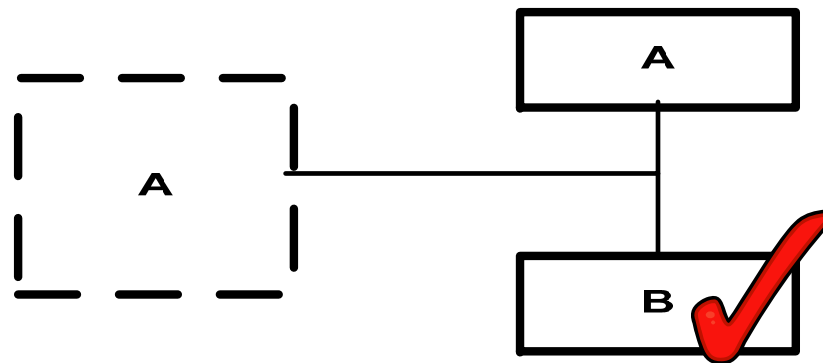

Scenario 1 - Illustrated Example of Simple Split



02/06/2008  
Date of Alteration to 2005  
rating List (effective 1 April 2005)

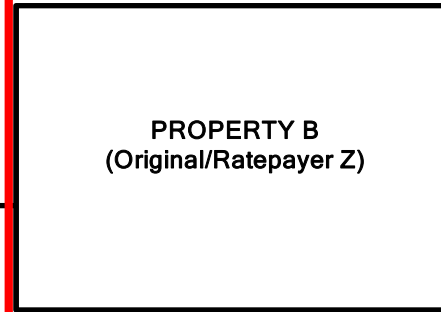

Start of 2005 ratings list  
01/04/2005

33 Months since start  
of 2005 Ratings List  
01/01/2008

Final Date for Changes  
to List to Qualify for Waiver  
31/03/2010

## Scenario 1 - Answers to Questions

### **Q1. Which properties are eligible for the waiver and why?**

Property C is entitled to a waiver as it is clearly the result of a split – as it was removed from the assessment of the now deleted property A and entered onto the rating list in its own right before 31 March 2010. It has incurred a backdated liability of more than 33 months (1 April 2005 to 2 June 2008 = 38 months) and the ratepayer of Property C (ratepayer Y) was not responsible for rates on the now deleted Property A. Therefore Property C is entitled to the waiver.

### **Q2. What is the eligible period of backdated liability and why?**

A. 1 April 2005 to 2 June 2008 because that was the date of initial alteration to the list which inserted the new properties. Thereafter, any rates are ongoing rates.

### **Q3. Which Property is not eligible for the waiver & why?**

Properties B and D are not eligible for the waiver. This is because, although formed by a split before 31 March 2010, the ratepayer for both properties is ratepayer Z. These properties were split from the assessment of the now deleted Property A, in respect of which ratepayer Z was also responsible for the rates bill. Therefore Properties B and D are not eligible for the waiver.

# Scenario 2- Example of a Split Property That Does Not Qualify For the Waiver



15/04/2010  
Date of Alteration to 2005  
rating List (effective 1 April 2005)

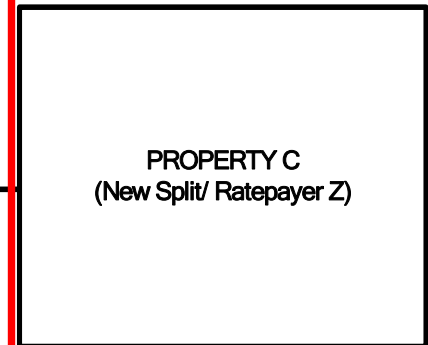
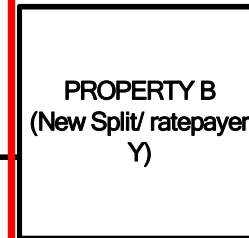

Start of 2005 ratings list  
01/04/2005

33 Months since start  
of 2005 Ratings List  
01/01/2008

Final Date for Changes  
to List to Qualify for Waiver  
31/03/2010

## Scenario 2 – Answers to Questions

**Q1. Which properties are eligible for the waiver and why?**

A. None of the properties in this example are entitled to the waiver.

**Q2. What is the eligible period of backdated liability and why?**

A. N/A

**Q3. Which Property is not eligible for the waiver & why?**

A. Both properties remaining on the list are not eligible. This is because although formed by a split, working backwards, neither property B or C meets the waiver criteria in themselves because they were entered on the list after 31 March 2010. In addition, Property C is occupied by the same ratepayer as Property A and therefore is also ineligible for that reason. Both properties have been split from the now deleted property A which in itself also does not meet the waiver criteria – therefore neither Property B or C is entitled to a waiver.



# Split of Splits

It is possible that once a new property has been entered onto the rating list due to it being split, that this entry is deleted and replaced by further new entries (splits of splits). These further changes can mean that in themselves, the split of a split is not eligible for the waiver (eg if as a result of a proposal or any other criteria), or it could, where all the criteria is met including that of a new ratepayer becoming liable for rates on that property, mean that a new property is eligible for the waiver. The following examples set out some of the different occurrences and how these should be treated.

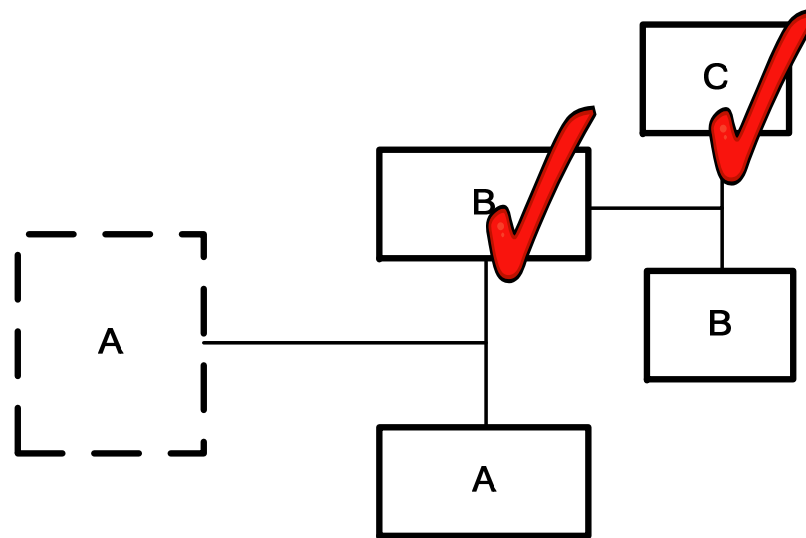

### Scenario 3 - Illustrated Example of Split after 31 March 2010

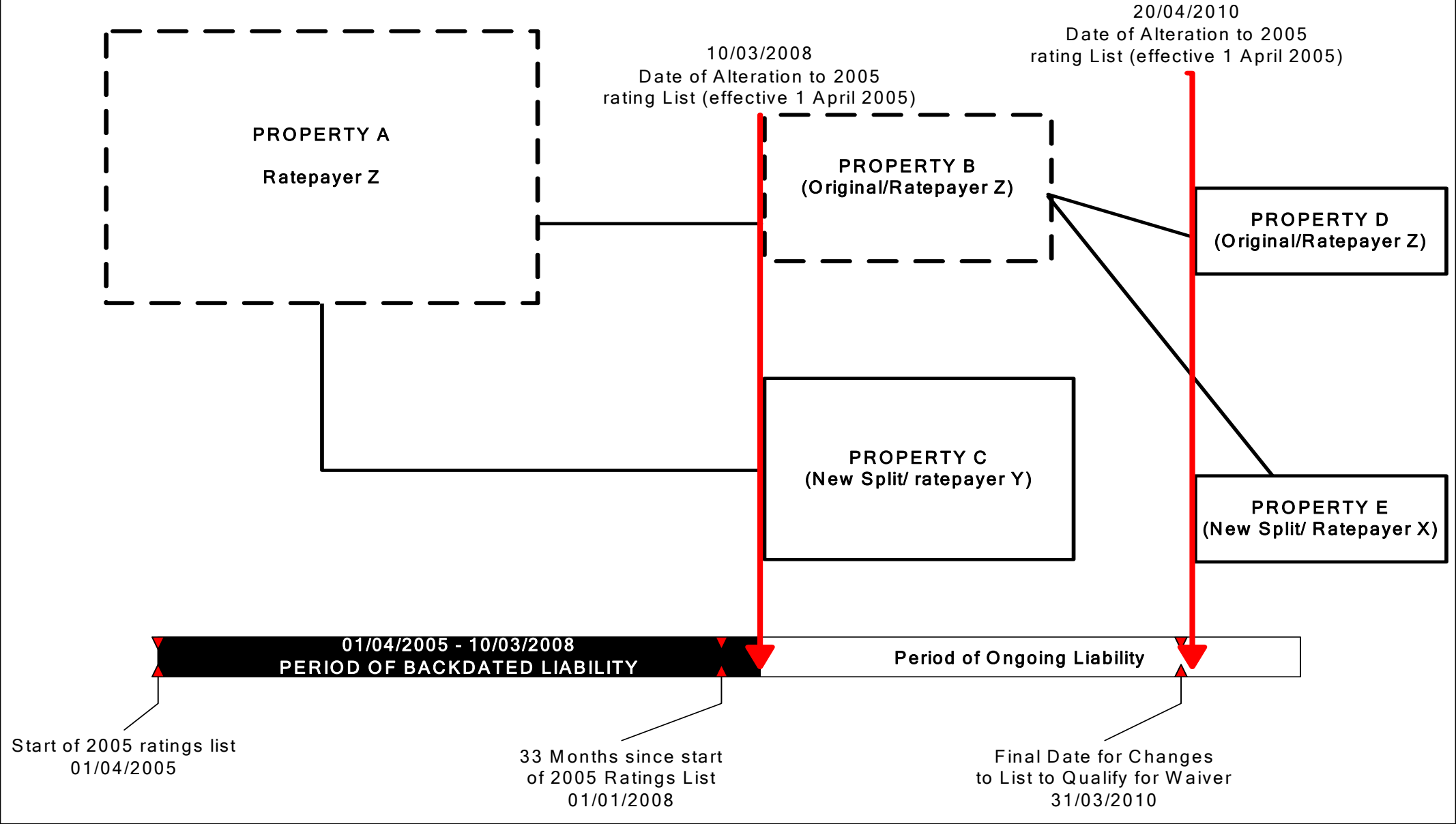

### Scenario 3 - Answers to Questions

**Q1. Which properties are eligible for the waiver and why?**

- A. Property C is entitled to a waiver because it incurred a backdated liability following it being split before 31 March 2010 from the assessment of the now deleted Property A; the backdated liability is for more than 33 months (1 April 2005 to 10 March 2008 = 35 months) and the ratepayer for Property C was not responsible for rates on the property it was split from (A). Therefore it is entitled to the waiver.

**Q2. What is the eligible period of backdated liability and why?**

- A. 1 April 2005 to 10 March 2008 because Property C should have been listed separately on the rating list before 1 April 2005 and therefore the listing was backdated. However it was entered on the list on 10 March 2008 and therefore anything after that date would be ongoing liabilities.

**Q3. Which Property is not eligible for the waiver & why?**

- A. There are now three properties left in the rating list in the above scenario. We have determined that of these three only Property C is eligible for the waiver, therefore the remaining properties, D and E are not. This is because working backwards, properties D and E do not meet the date criteria (as although formed by a split they were added to the list after 31 March 2010). Furthermore, one of the properties, Property D is occupied by the same ratepayer as the now deleted property B. Therefore neither property meets the criteria in themselves. So we move to the property they were split from, the now deleted Property B – this property was not entitled to the waiver either as although formed by a split before 31 March 2010 the ratepayer for the property was the one responsible for the now deleted Property A – and Property A was not entitled to the waiver as it was on the rating list as of 1 April 2005. Therefore properties D and E are not entitled to any waiver.

# Scenario 4

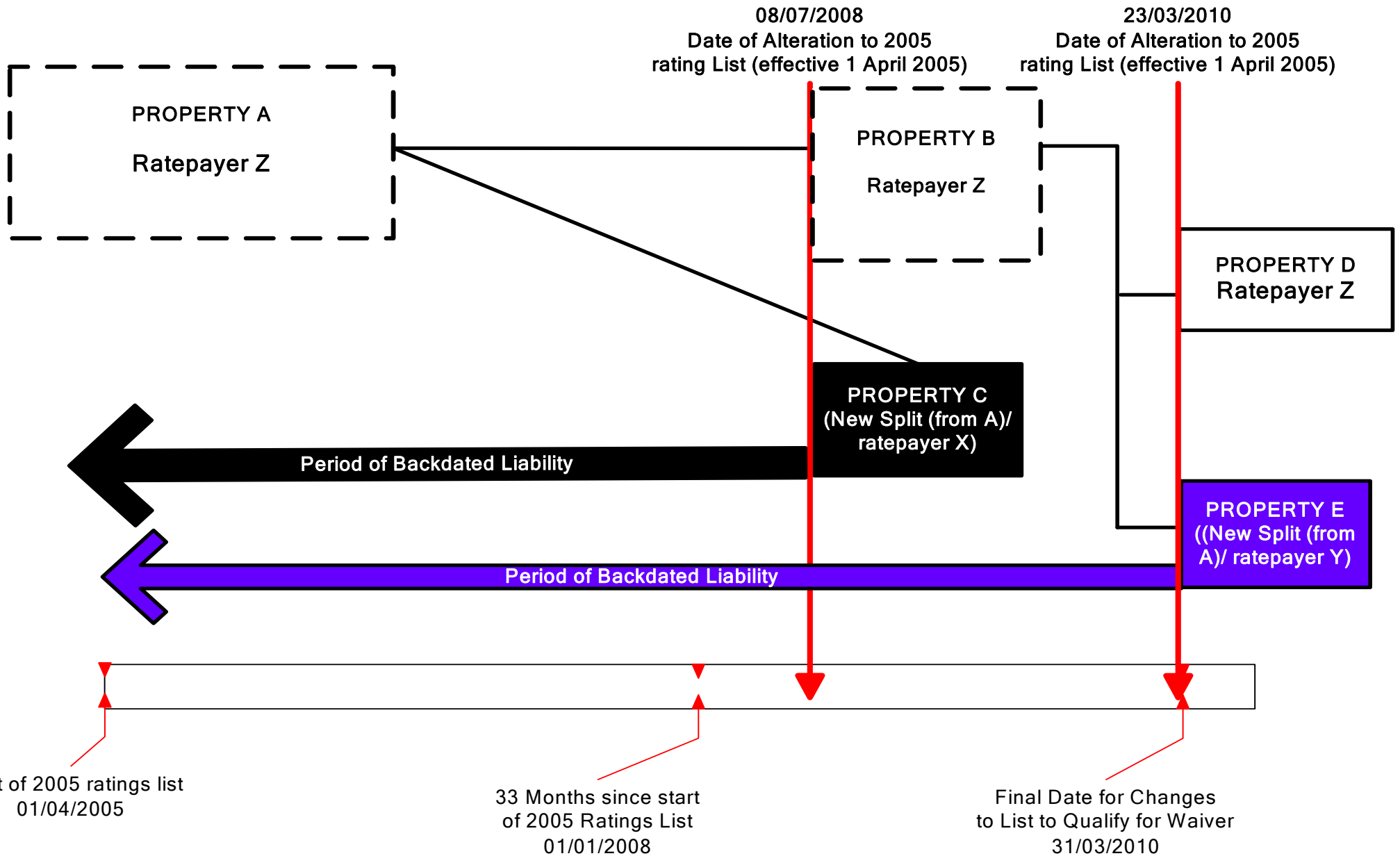

## Scenario 4 – Answers to Questions

### **Q1. Which properties are eligible for the waiver & why?**

- A. Properties C and E are eligible for the waiver. Property C is entitled to a waiver as it is clearly the result of a split –because it was removed from the assessment of the now deleted property A and entered onto the rating list in its own right before 31 March 2010. It has incurred a backdated liability of more than 33 months (1 April 2005 to 8 July 2008 = 39 months) and the ratepayer of Property C (ratepayer X) was not responsible for rates on the now deleted Property A. Therefore Property C is entitled to the waiver. Property E is entitled to the waiver for the same reasons as C, However, as shown on the diagram above, as its alteration date is later than that of C, Property E has a more lengthy backdated liability.

### **Q2. What is the eligible period of backdated liability and why?**

- A. For property C it is 1 April 2005 to 8 July 2008 because that is the date it was added to the rating list. In the case of Property E it is 1 April 2005 to 23 March 2010. Property C is liable for ongoing rates from 9 July 2008 and Property E from 24 March 2010.

### **Q3. Which Property is not eligible for the waiver & why?**

- A. Property D is not eligible for the waiver. In this case we can see that D is not entitled to the waiver in itself as, although formed by a split prior to 31 March 2010, the ratepayer is the same one responsible for rates on the property it was split from (the now deleted property B). We then work backwards and can see that the property it was split from (Property B) also wasn't entitled to a waiver as the property it was split from (A) was occupied by the same ratepayer. By tracing our way back to property A we have reached the end of the 2005 rating list and therefore we do not need to look any further – we can see that D is not entitled to a waiver.

### Scenario 5

26/03/2008  
Date of Alteration  
to 2005 rating List  
(effective 1 April 2005)

10/05/2010  
Date of Alteration  
to 2005 rating List  
(effective 1 April 2005)

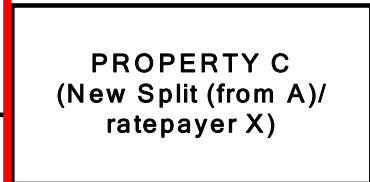
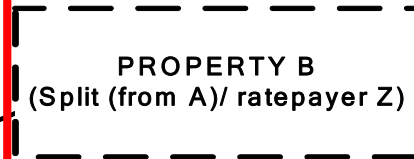
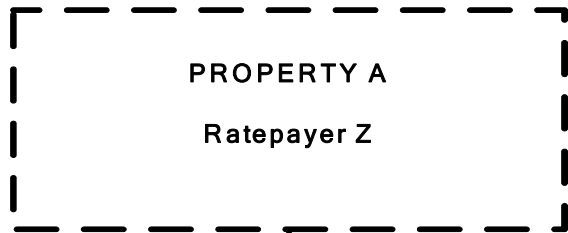

Start of 2005 ratings list  
01/04/2005

33 Months since start  
of 2005 Ratings List  
01/01/2008

Final Date for Changes  
to List to Qualify for Waiver  
31/03/2010

## Scenario 5 - Answers to Questions

### Q1. Which properties are eligible for the waiver & why?

- A. Property C is entitled to a waiver as it is clearly the result of a split – as it was removed from the assessment of the now deleted property A and entered onto the rating list in its own right prior to 31 March 2010. It has incurred a backdated liability of more than 33 months (1 April 2005 to 26 March 2008 = 35 months) and the ratepayer of Property C (ratepayer X) was not responsible for rates on the now deleted Property A. Therefore Property C is entitled to the waiver.

### Q2. What is the eligible period of backdated liability and why?

- A. 1 April 2005 to 26 March 2008 because that is the date Property C was added to the rating list. Property C liable for ongoing rates from 27 March 2008.

### Q3. Which Property is not eligible for the waiver & why?

- A. Properties D and E are not entitled to a waiver as they were added to the rating list after 31 March 2010. Property D is also not entitled to the waiver because working through the split chain we can see that ratepayer Z, was liable for rates on the original property that D has been split from. **Please refer to the answer in Q3 in Scenario 4 for a more detailed explanation.** When we work backwards through the chain of splits that it is derived from (Property B and finally property A) we can see that at no point was ratepayer X entitled to a waiver in relation to the properties that it has been split from. Do not be confused by the fact that ratepayer X is entitled to a waiver for Property C. This has been defined for rating as a separate hereditament and therefore is treated and looked at separately.

### Scenario 6

30/04/2008  
Date of Alteration to 2005  
rating List (effective 1 April 2005)

24/06/2010  
Date of Alteration to 2005  
rating List (effective  
1 April 2005)



Start of 2005 ratings list  
01/04/2005

33 Months since start  
of 2005 Ratings List  
01/01/2008

Final Date for Changes  
to List to Qualify for Waiver  
31/03/2010



## Scenario 6 - Answers to Questions

### Q1. Which properties are eligible for the waiver & why?

- A. Property D is entitled to a waiver. Property D is not entitled to the waiver in itself as it was added to the rating list after 31 March 2010 and that ratepayer (X), responsible for rates on Property D, was also responsible for rates on the property it was split from. However, working backwards we can see that it was split from the now deleted Property C which was entitled to the waiver. This is because Property C was split before 31 March 2010 from the assessment of another property (A), incurred a backdated rates bill of more than 33 months (1 April 2005 to 30 April 2008 =36 months) and the ratepayer for Property C (ratepayer X) was not liable for rates on the property it was split from, A. Therefore, although not eligible in itself, the waiver for the period 1 April 2005 to 30 April 2008 is transferred from the now deleted Property C to Property D.

### Q2. What is the eligible period of backdated liability and why?

- A. 1 April 2005 to 30 April 2008 – because Property D is not eligible in itself and instead the eligibility of the now deleted Property C is transferred to D, as the ratepayer for both is the same. Property D is liable for ongoing rates from 1 May 2008.

### Q3. Which Property is not eligible for the waiver & why?

Properties B and E are not eligible for the waiver. In the case of Property B this is because the ratepayer in occupation of Property B is the same who was responsible for rates on the property it was split from, the now deleted Property A. However, in the case of Property E we can see again, that it is not entitled to a waiver in itself as it was added to the list after 31 March 2010. We then work backwards and can see that the property it was split from (Property C) would have been entitled to a waiver however this cannot be transferred to Property E. This is because we work through the chain of splits that led to the insertion of Property E to the rating list we can see that the now deleted Property A, which Property C was split from, was also occupied by ratepayer Z. Ratepayer Z is therefore not entitled to a waiver for Property E.

### Scenario 7 - Further Split of a Split

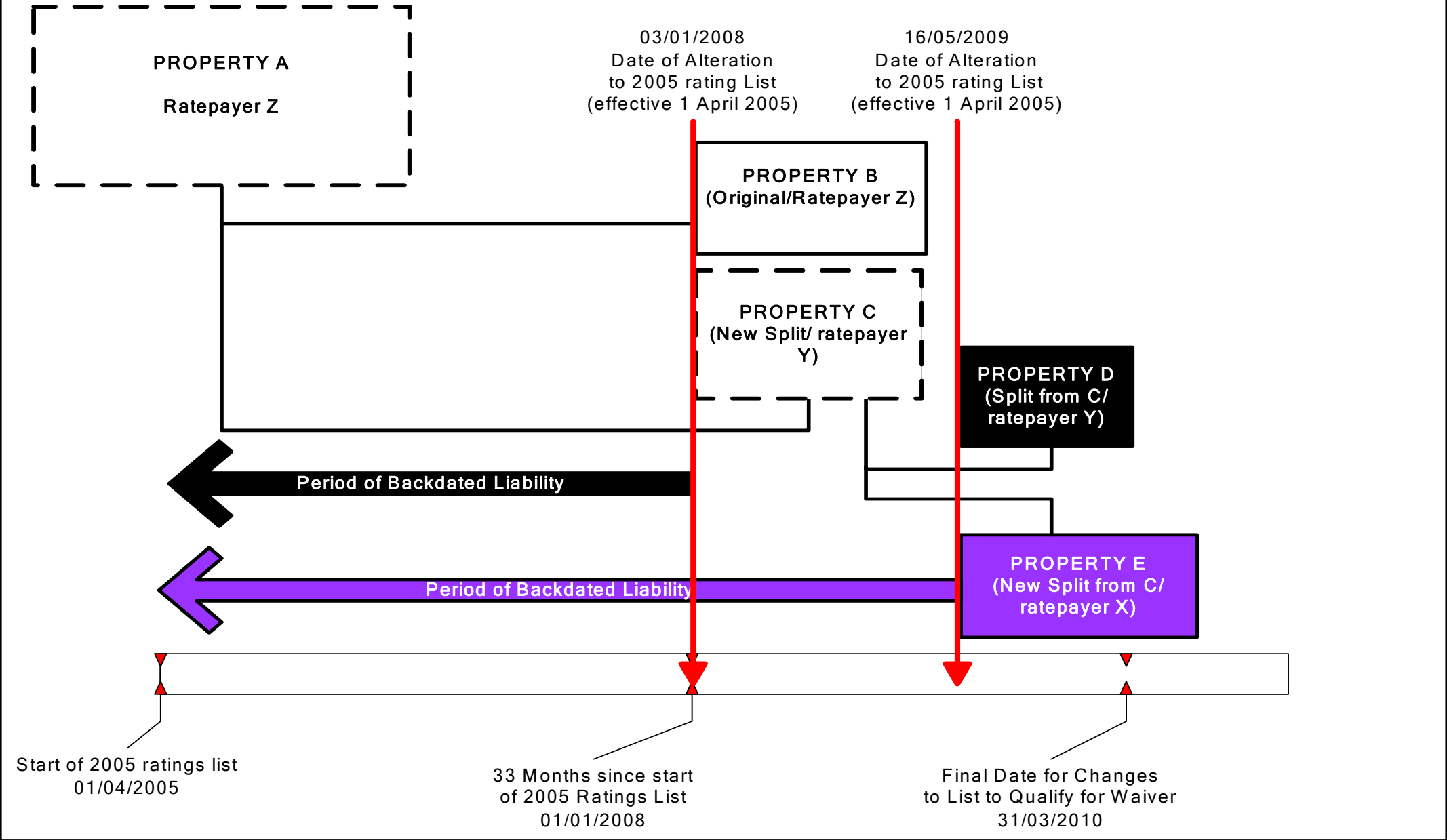

## Scenario 7 – Answers to Questions

### Q1. Which properties are eligible for the waiver?

- A. Properties D and E are entitled to a waiver. In respect of Property D, the eligibility of the now deleted Property C is transferred to it as the ratepayer for both is the same. **Please refer to the answer provided under Q1 in Scenario 6 for a more detailed explanation.** Property E meets the waiver criteria in that it is the result of a split prior to 31 March 2010 and has incurred a backdated liability of more than 33 months (1 April 2005 to 16 May 2009 = 49 months). We then look at the property it was split from (the now deleted Property C) and can see that the ratepayer for E is not the same as C. However we must work backwards through the various splits to ensure that ratepayer X was not liable for rates on the properties within the split chain in its various guises. In this case the earliest property is A, and we can see that ratepayer X was not liable for rates on this and is therefore entitled to the waiver.

### Q2. What is the eligible period of backdated liability and why?

- A. For property D it is 1 April 2005 to 3 January 2008 and is liable for ongoing rates from 4 January 2008. For property E it is 1 April 2005 to 16 May 2009 and Property E is liable for ongoing rates from 17 May 2009.

### Q3. Which Property is not eligible for the waiver & why?

- A. Property B is not entitled to the waiver. This is because although it was split before 31 March 2010, it was split from Property A which was occupied by the same ratepayer, Z.

Scenario 8 - Further Out Of Time Split of a Split

PROPERTY A  
Ratepayer Z

29/03/2008  
Date of Alteration to 2005  
rating List (effective 1 April 2005)

PROPERTY B  
(Original/Ratepayer Z)

01/04/2010  
Date of Alteration to 2005  
rating List (effective  
1 April 2005)

PROPERTY C  
(New Split/ ratepayer  
Y)

PROPERTY D  
(Split from C/ ratepayer  
Y)

PROPERTY E  
(New Split from C/  
ratepayer X)

01/04/2005 - 29/03/2008  
PERIOD OF BACKDATED LIABILITY

Ongoing Liability

Start of 2005 ratings list  
01/04/2005

33 Months since start  
of 2005 Ratings List  
01/01/2008

Final Date for Changes  
to List to Qualify for Waiver  
31/03/2010

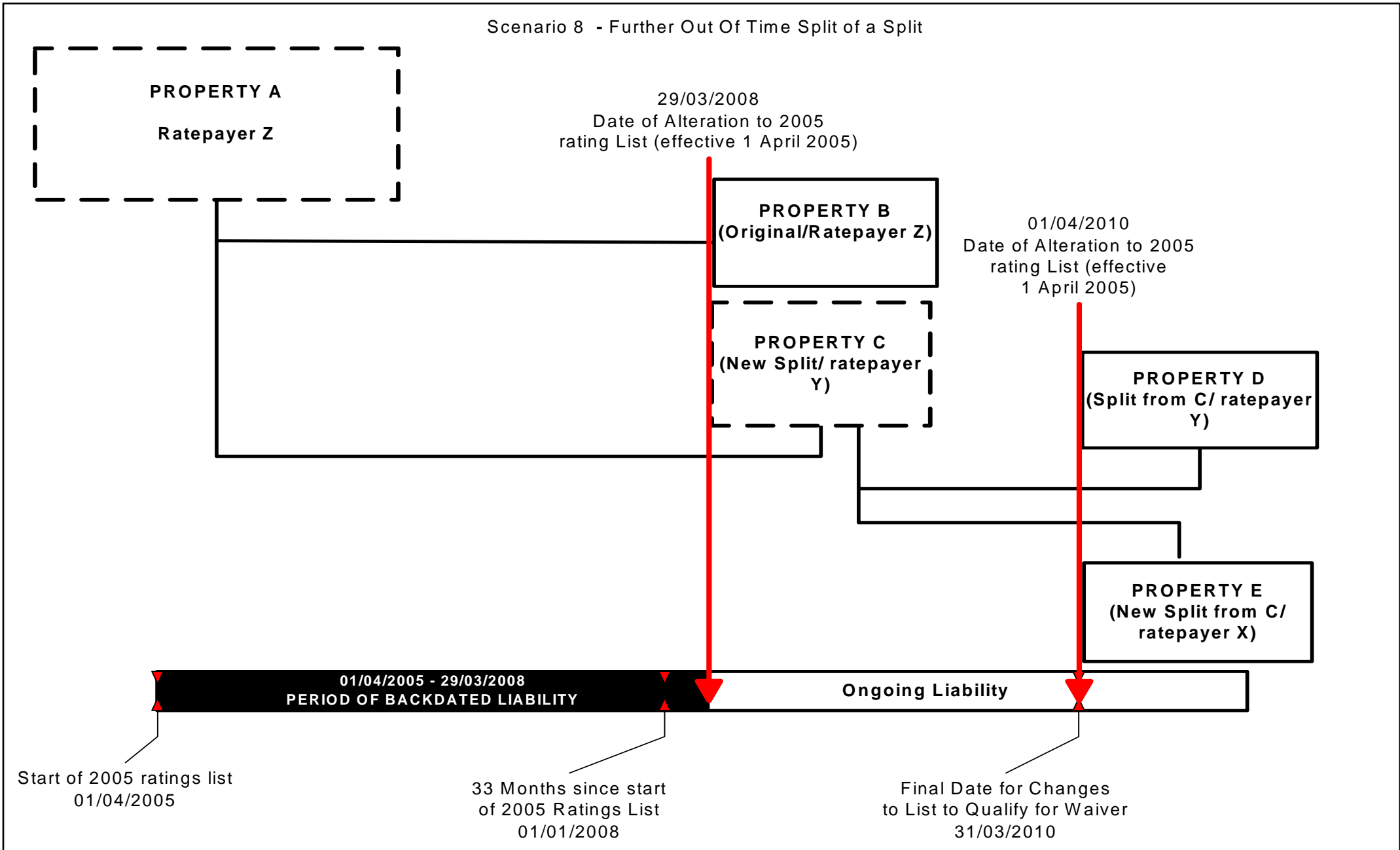

## Scenario 8 - Answers to Questions

### Q1. Which properties are eligible for the waiver & why?

- A. Property D is entitled to a waiver – although not entitled in itself as the split occurred after 31 March 2010, and the ratepayer is the same as the preceding property, the eligibility of the now deleted Property C is transferred to it because the ratepayer for both is the same. **Please refer to the answer provided under Q1 in Scenario 6 for a more detailed explanation).**

### Q2. What is the eligible period of backdated liability and why?

- A. 1 April 2005 to 29 March 2008 – because Property D is not eligible in itself and instead the eligibility of the now deleted Property C is transferred to D, as the ratepayer for both is the same. Property D is liable for ongoing rates from 30 March 2008

### Q3. Which Property is not eligible for the waiver & why?

- A. Property E is not eligible for the waiver. This is because unlike Scenario 7, the ratepayer does not meet the waiver criteria as E was added to the list after the cut off date of 31 March 2010. Working backwards we need to check whether any eligibility of previous splits within the chain that led to Property E being inserted on the list was entitled to the waiver and whether this would then be transferred to ratepayer X in respect of E. Looking at all the properties in the chain, C and finally A, which takes us to the start of the 2005 rating list, we can see that although property C was entitled to a waiver this is only transferred to the ratepayer who received that backdated liability – property D. As ratepayer X did not become liable for rates until April 2010 property E can only be judged on its own merits and as it did not meet the criteria is not entitled to the waiver.

# Mergers

Mergers in themselves are not eligible for the waiver but when combined with a split somewhere along the chain of alterations to the list, of any part of the same property, the eligibility criteria may be met. Some examples are set out below.

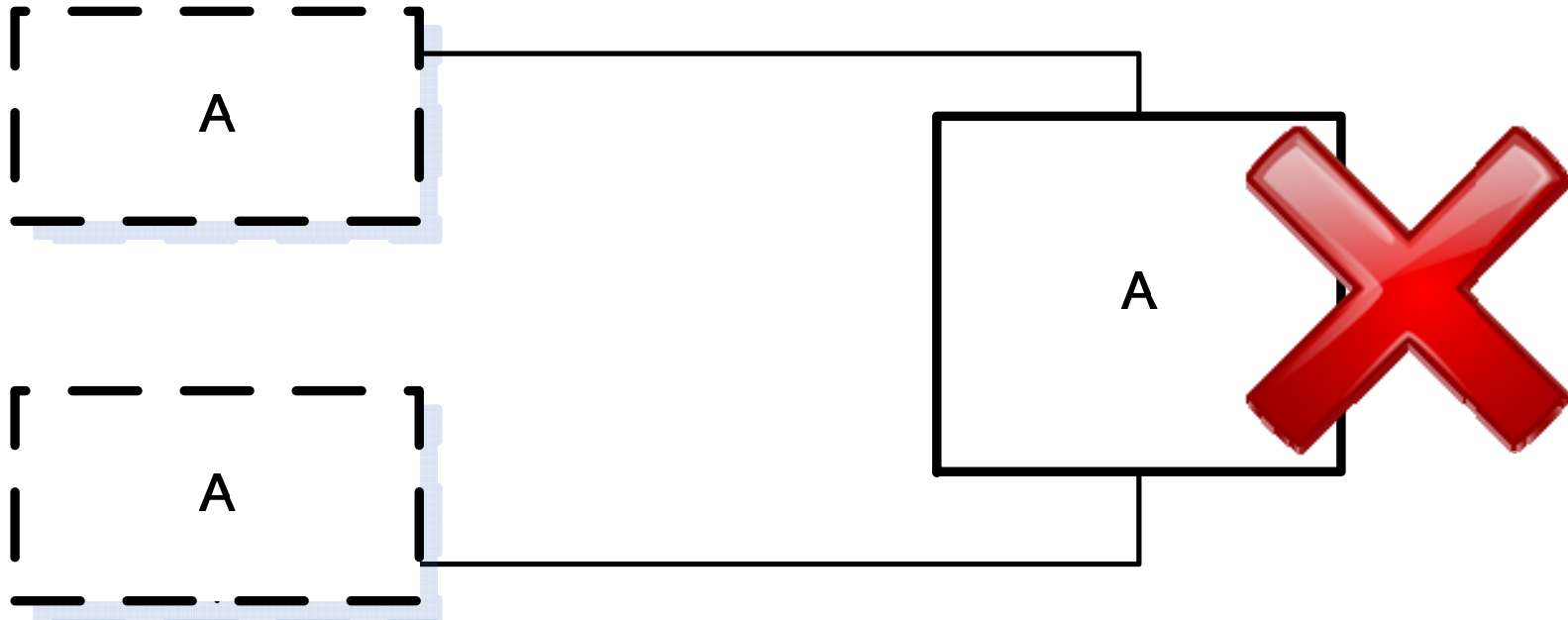

# Scenario 9 - Illustrated Examples of Mergers

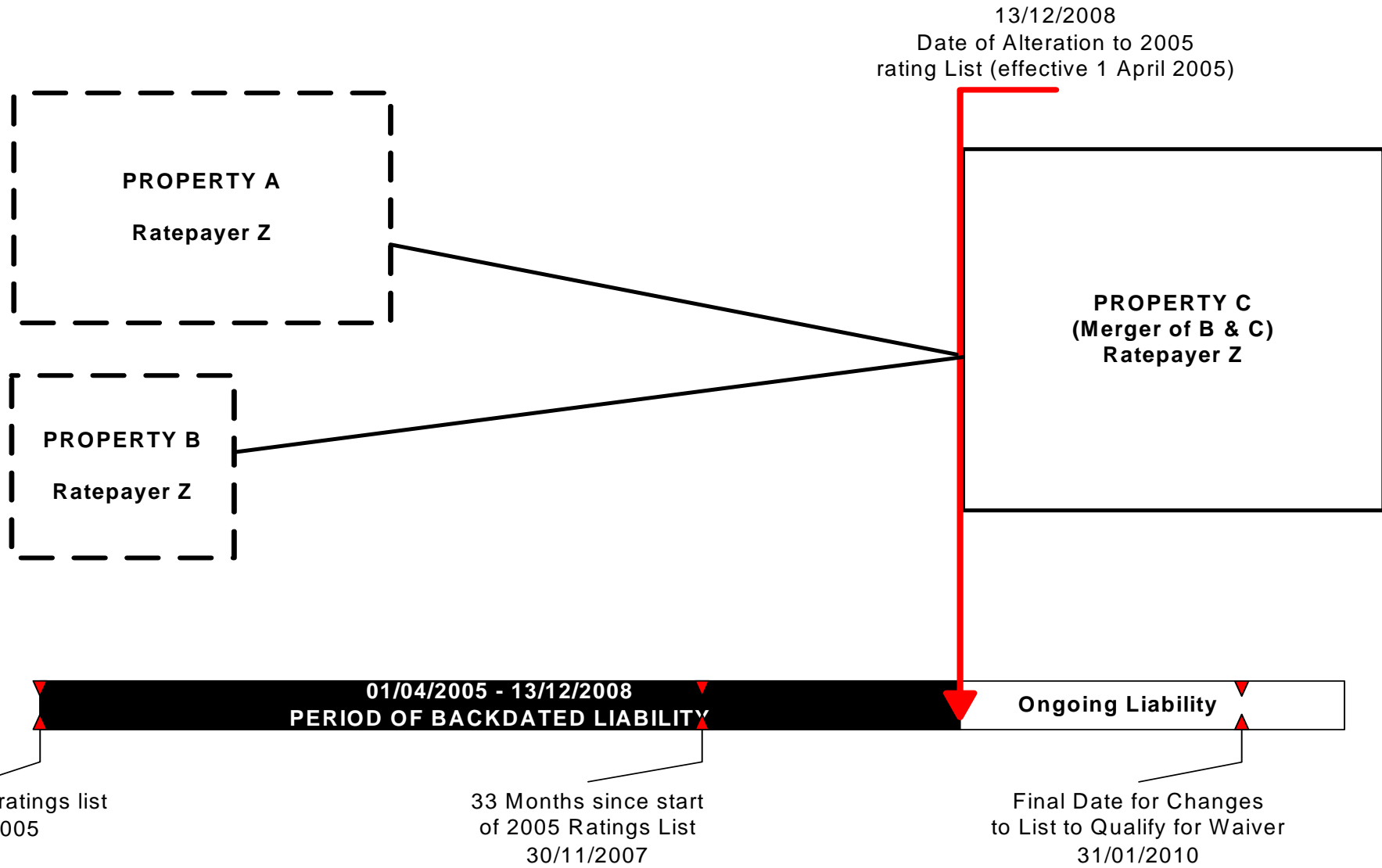

## Scenario 9 – Answers to Questions

**Q1. Which properties are eligible for the waiver & why?**

A. None. Although Property C was inserted on the list within the eligible period before 31 March 2010, it is not the result of a split and therefore there is no entitlement to a waiver.

**Q2. What is the eligible period of backdated liability and why?**

A. N/A

**Q3. Which Property is not eligible for the waiver & why?**

A. Property C is not eligible for the waiver. This is because Property C was the result of a merger and working backwards to the start of the 2005 rating list we can see that there were no eligible splits in the chain of property changes for C. Therefore it is not eligible.



# Mergers & Splits

Once a property has been split from the assessment of another hereditament, it is possible that further changes are made to the list which may include, for example, another merger. In certain cases, such actions will result in the merged property no longer being liable for a waiver. Mergers in themselves are not eligible for the waiver but when combined with a split somewhere along the chain of alterations to the list, of any part of the same property, the eligibility criteria may be met. Some examples are set out below.

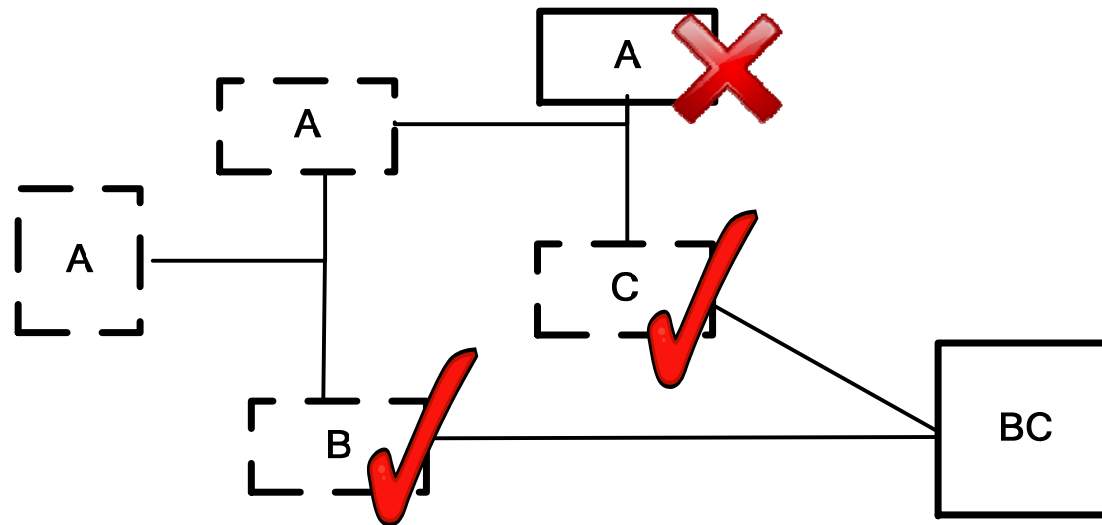

Scenario 10 - Illustrated Examples of Mergers

PROPERTY A  
Ratepayer Z

03/09/2008  
Date of Alteration to 2005  
rating List (effective 1 April 2005)

PROPERTY B  
(Split from A)  
Ratepayer Z

PROPERTY C  
(New Split from A)  
Ratepayer X

18/10/2009  
Date of  
Alteration to  
2005 rating List  
(effective  
1 April 2005)

PROPERTY D  
(New Split from A)  
Ratepayer X

PROPERTY E  
(Merger of C & D)  
Ratepayer X

01/04/2005 - 03/09/2008  
PERIOD OF BACKDATED LIABILITY

Ongoing Liability

Start of 2005 ratings list  
01/04/2005

33 Months since start  
of 2005 Ratings List  
30 November 2007

Final Date for Changes  
to List to Qualify for Waiver  
31 January 2010

## Scenario 10 - Answers to Questions

### **Q1. Which properties are eligible for the waiver & why?**

- A. Property E inherits the waiver from Properties C and D. Although in itself Property E does not meet the eligibility criteria, as Property E is not formed by a split, Properties C and D are eligible because they were formed by a split of property before 31 March 2010 and the occupier of these properties was not the same as the preceding property A.

### **Q2. What is the eligible period of backdated liability and why?**

- A. 1 April 2005 to 3 September 2008 – because the eligibility for the waiver is transferred to property E from the now deleted properties C and D who were entitled to the waiver for the period 1 April 2005 to 3 September 2008. After that date Ratepayer X would have been liable for ongoing liabilities.

### **Q3. Which Property is not eligible for the waiver & why?**

- A. Property B is not eligible for the waiver. This is because the ratepayer for Property B was the one responsible for the original property A from which property B was split out. Therefore the rates could not have been unexpected.

# Scenario 11 - Illustrated Example of Mergers

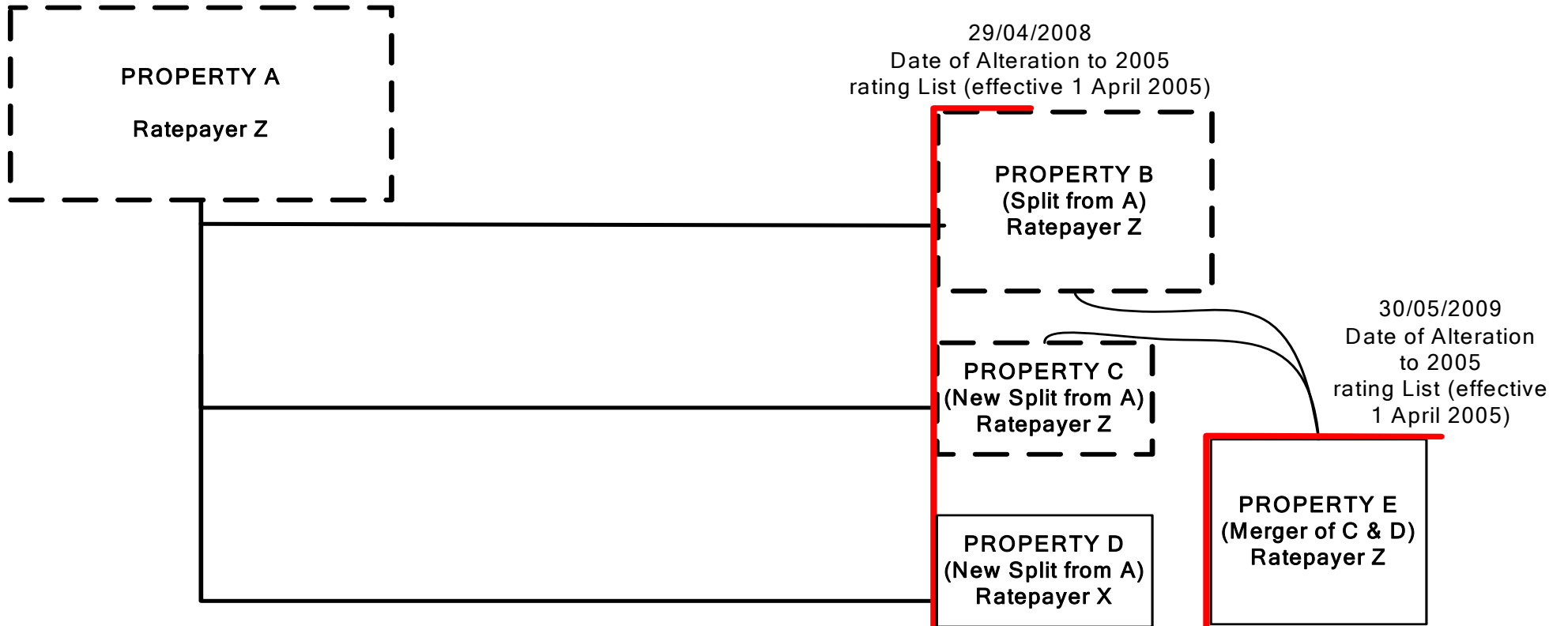

Start of 2005 ratings list  
01/04/2005

33 Months since start  
of 2005 Ratings List  
30/11/2007

Final Date for Changes  
to List to Qualify for Waiver  
31/01/2010

## Scenario 11 – Answers to Questions

**Q1. Which properties are eligible for the waiver & why?**

- A. Property D is entitled to the waiver because it is the result of a split, meets the 33 month criterion and ratepayer X was not responsible for rates on this property until the split on 29 April 2009.

**Q2. What is the eligible period of backdated liability and why?**

- A. 1 April 2005 to 29 April 2008 as this was the date property D was added to the rating list. Property D is liable for ongoing rates from 30 April 2008.

**Q3. Which Property is not eligible for the waiver & why?**

- A. Property E is not eligible for the waiver as it is not the result of a split property. Also this is because the ratepayer for Property E was the one responsible for the original property A from which Property E is derived.

Scenario 12 - Illustrated Example of Split & Merger

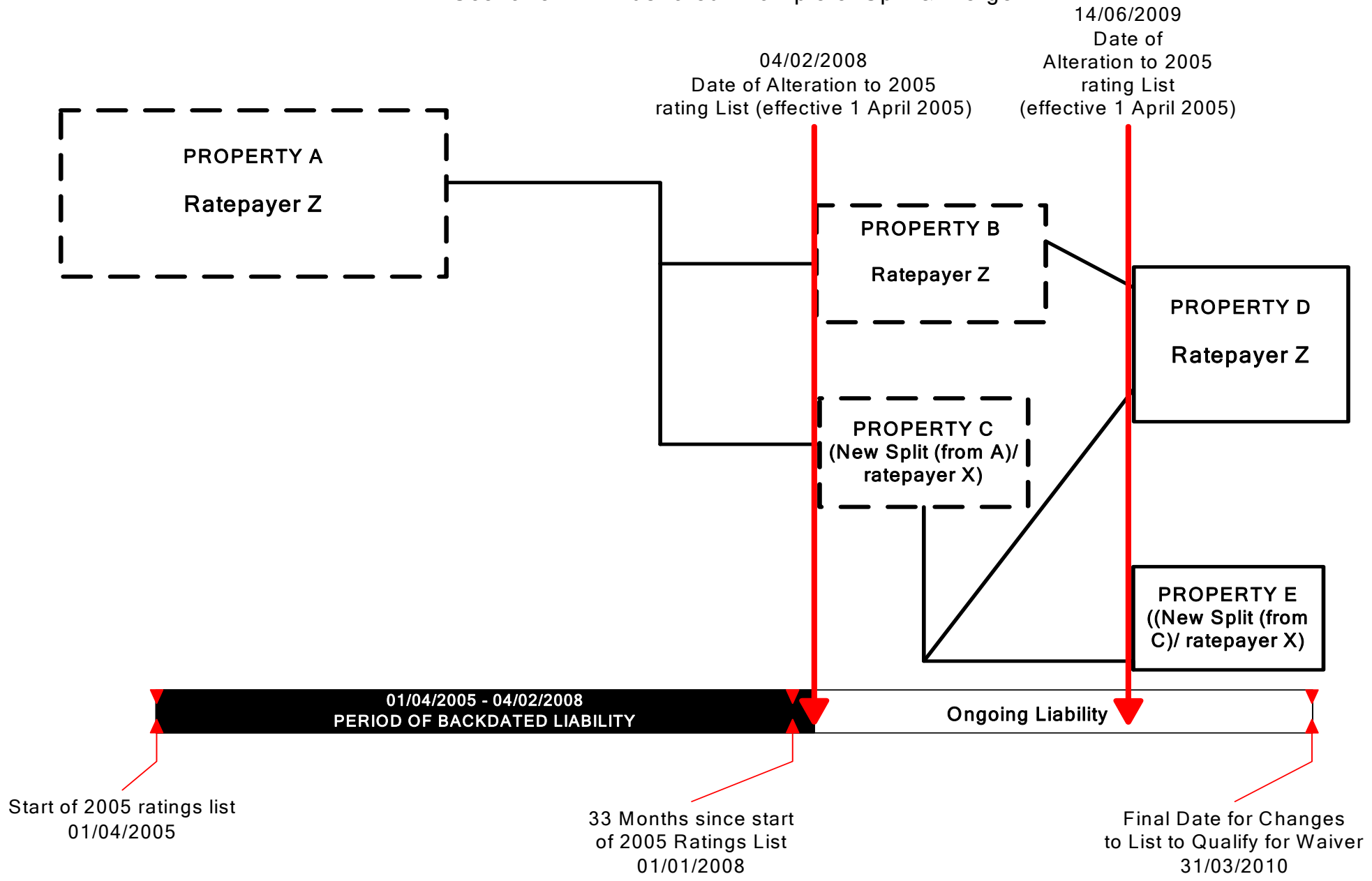

## Scenario 12 - Answers to Questions

### **Q1. Which properties are eligible for the waiver & why?**

- A. Property E is not in itself entitled to a waiver because although it has been split from Property C and added to the rating list before 31 March 2010, the ratepayer was liable for rates on the now deleted Property C (from which it was split). However, as Property C was entitled to a waiver (because it was split from a property, added to the rating list before 31 March 2010, and ratepayer X was not liable for rates on the now deleted Property A (from which it was split). So the eligibility of Property C is transferred to Property E.

### **Q2. What is the eligible period of backdated liability and why?**

- A. Property E is entitled to a waiver from 1 April 2005 to 4 February 2008 as this was the date Property C was added to the rating list. Property E is liable for ongoing rates from 5 February 2008 onwards

### **Q3. Which Property is not eligible for the waiver & why?**

- A. Property D is not eligible for the waiver. This is because although D was partly formed from a split of Property C, ratepayer Z , was in fact responsible for rates on the original property (the now deleted Property A) and therefore is not entitled to the waiver.

# Mergers of Splits with Non Splits

It is possible that hereditaments that have been identified and added on the rating list are then found to be larger than previously understood. This could give rise to the merger of a split property with a non split or a new build. Remember - mergers in themselves are not eligible for the waiver but when combined with a split somewhere along the chain of alterations to the list, of any part of the same property, the eligibility criteria may be met. Some examples are set out below.

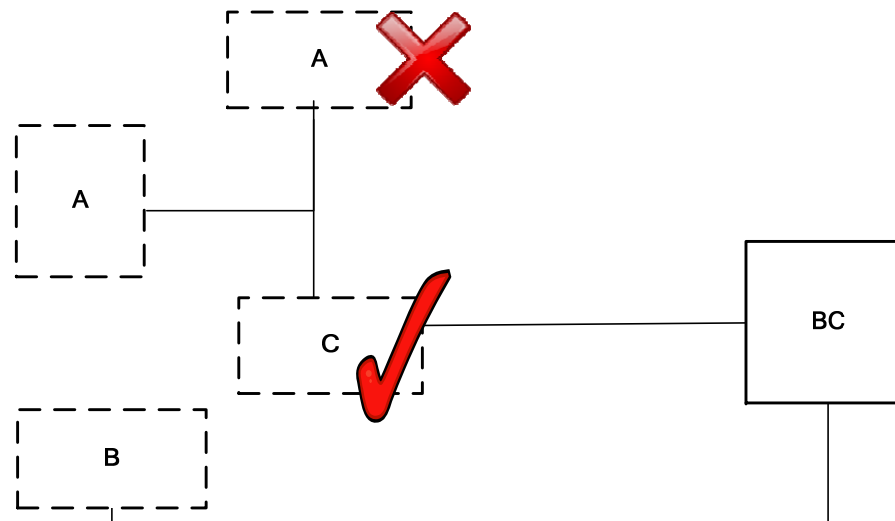



# Scenario 13 - Illustrated Example of Split & Merger

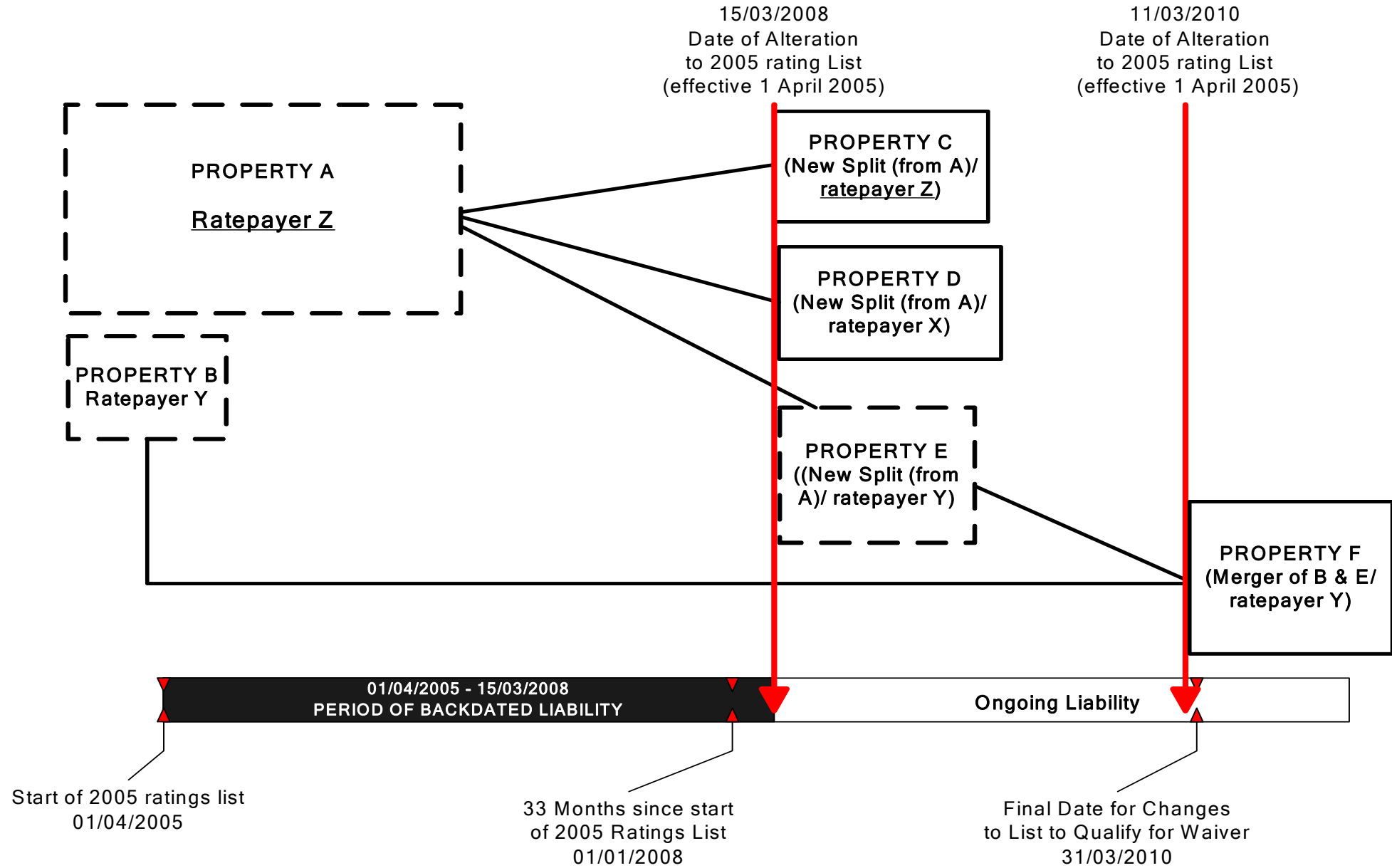

### Scenario 13 – Answers to Questions

**Q1. Which properties are eligible for the waiver & why?**

- A. Properties D and F are entitled to a waiver. Property D is entitled because it is a straight forward split from the now deleted Property A; was added to the rating list before 31 March 2010; the ratepayer incurred a backdated rates bill of more than 33 months and became liable for the first time for rates on any part of that property following the split. Property F is not in itself entitled to a waiver as it is not the result of a split but a merger of two existing properties. However it is entitled to a waiver because eligibility is transferred from the now deleted Property E. Looking at the diagram, we can see that in itself, Property E would have been entitled to the waiver for the same reasons as property D.

**Q2. What is the eligible period of backdated liability and why?**

- A. For both properties D and F it is 1 April 2005 to 15 March 2008. This is because 15 March was the date when ratepayer X and Y first became liable for rates on a portion of properties previously assessed under A and after that date, those ratepayers were liable for ongoing rates.

**Q3. Which Property is not eligible for the waiver & why?**

- A. Property C is not eligible for the waiver. This is because the ratepayer for Property C was the one responsible for the original property A.

# Scenario 14 - Illustrated Example of Mergers

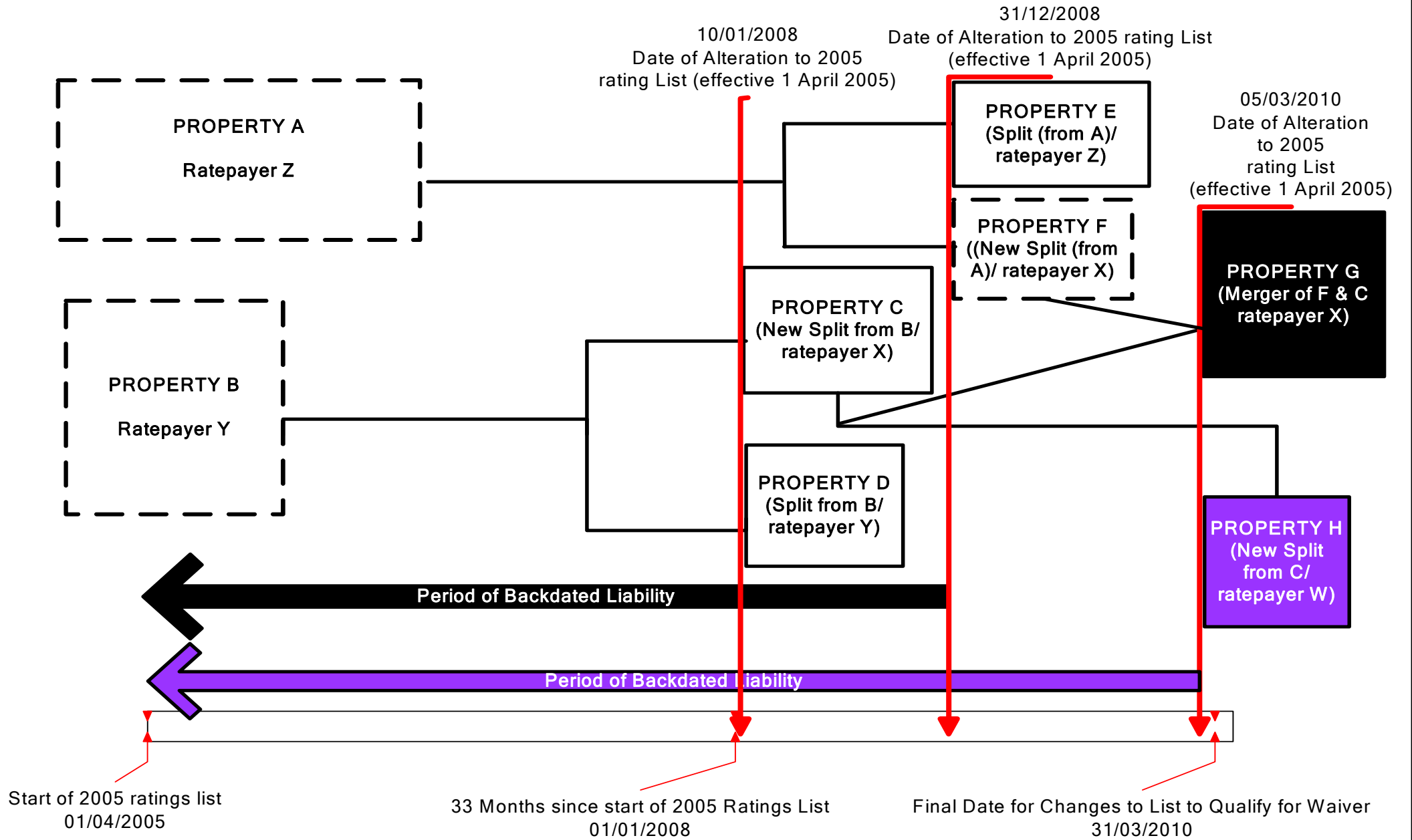

## Scenario 14 - Answers to Questions

### **Q1. Which properties are eligible for the waiver & why?**

- A. Properties G and H are entitled to the waiver. In this scenario, there are four properties left on the 2005 Rating list – Properties D, E, G and H. Property H, meets all the criteria for the waiver in itself, therefore it gets the cancellation for its backdated liability. Property G, in itself, is not entitled to the waiver. This is because it is occupied by Ratepayer X, who was liable for rates on both the properties which merged to create G (the now deleted C and F). However working backwards we can see that properties C and F were eligible for the waiver, therefore this eligibility is transferred to Property F but only for the chargeable days that C and F were entitled to the waiver.

### **Q2. What is the eligible period of backdated liability and why?**

- A. For property H it is 1 April 2005 to 5 March 2010. However for property G it is 1 April 2005 to 31 December 2008. This is because the eligibility for the waiver is transferred from the now deleted properties C and F (the latter being entitled to the waiver up to 31 December 2008) to property G. After that date, 1 January 2009, Ratepayer X and therefore property G would have been liable for ongoing liabilities.

### **Q3. Which Property is not eligible for the waiver & why?**

- A. Properties D and E are not eligible for the waiver. This is because the ratepayer for both these properties was the one responsible for the original property. So, In the case of property E, the ratepayer is Z, who was also the ratepayer in respect of Property A from which property E has been split. The same applies to D and ratepayer Y, who was responsible for rates on the now deleted Property B.

# Change in rateable value of property

There may be occasions where, for whatever reason, there are changes, such as in the rateable value of, which are backdated. However such a change does not in itself make the property eligible for a waiver. See the example below.

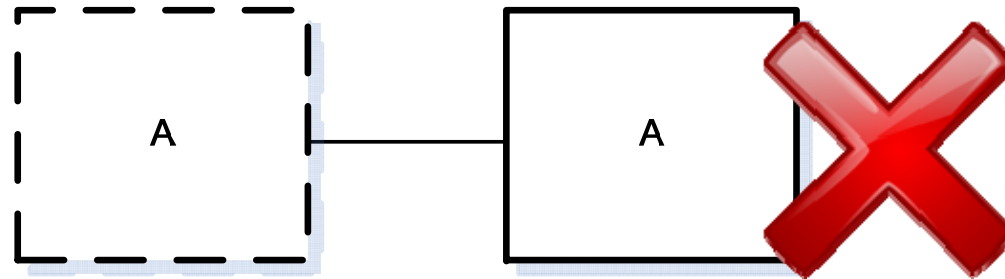

Scenario 15 - Rateable Value Change/Same Property Reinserted On List

PROPERTY A  
Ratepayer Z

27/06/2008  
Date of Alteration to 2005  
rating List (effective 1 April 2005)

PROPERTY B  
Ratepayer X

PROPERTY B  
(Property B with amended rateable  
value ratepayer X)

01/04/2005 - 27/06/2008  
PERIOD OF BACKDATED LIABILITY

Ongoing Liability

Start of 2005 ratings list  
01/04/2005

33 Months since start of 2005 Ratings List  
01/01/2008

Final Date for Changes to List to Qualify for Waiver  
31/03/2010

## Scenario 15 - Answers to Questions

**Q1. Which properties are eligible for the waiver & why?**

A. None – this is because the split criterion has not been met. Property B represents the same property except that its rateable value has changed and been backdated.

**Q2. What is the eligible period of backdated liability and why?**

A. N/A

**Q1. Which Property is not eligible for the waiver & why?**

A. There are 2 properties left in the rating list in this scenario – A and B. Neither of these is the result of a split and therefore neither is entitled to the waiver.

# Split Followed by Change in rateable value of property

There may be occasions where, for whatever reason, there are changes, such as in the rateable value of a property, which are backdated, after being split.

For example, if the rateable value is being amended or a small change has been made to the property. This may on occasion lead to a further backdated liability or appear to make the property ineligible for the waiver - however, as with mergers, the property may still be entitled to a waiver if there is a split involved. See the example below.

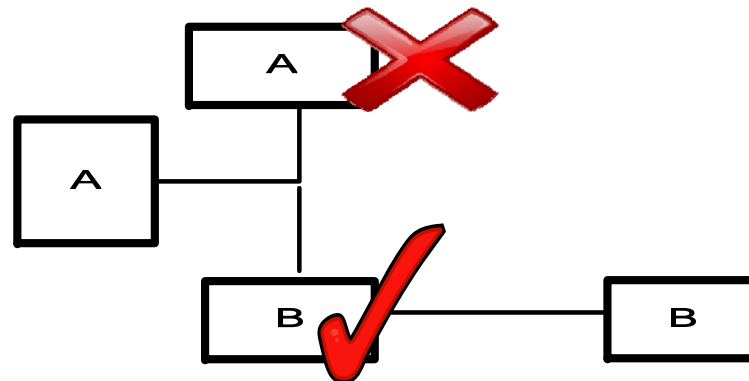



# Scenario 16 - Rateable Value Change/Same Property Reinserted On List

26/03/2008  
Date of Alteration to 2005  
rating List (effective 1 April 2005)

29/11/2009  
Date of Alteration to 2005  
rating List (effective 1 April 2005)

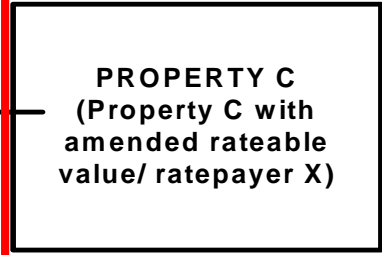
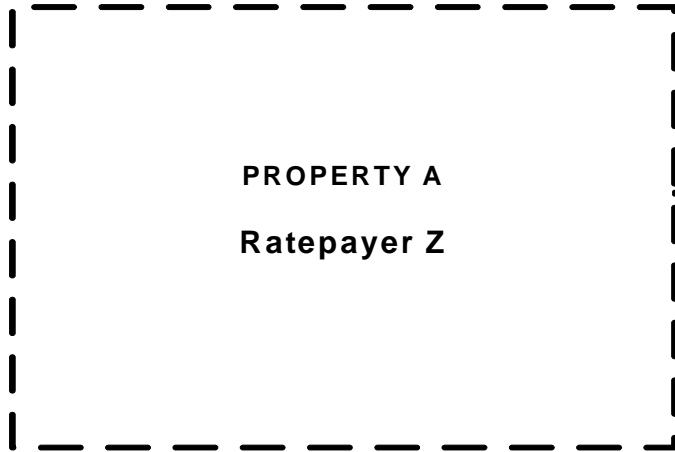

Start of 2005 ratings list  
01/04/2005

33 Months since start  
of 2005 Ratings List  
01/01/2008

Final Date for Changes  
to List to Qualify for Waiver  
31/03/2010

## Scenario 16 – Answers to Questions

**Q1. Which properties are eligible for the waiver & why?**

A. Property C is entitled to the waiver. Working backwards we can see that the Property C is eligible due to its insertion in the rating list on 26 March 2008 and a change in rateable value later on does not negate that entitlement.

**Q2. What is the eligible period of backdated liability and why?**

A. 1 April 2005 to 26 March 2008.

**Q3. Which Property is not eligible for the waiver & why?**

A. Property B is not eligible for the waiver. This is because the ratepayer for Property B was the one responsible for the original property A from which Property B has been split.

Scenario 17 - Rateable Value Change/Same Property Reinserted On List

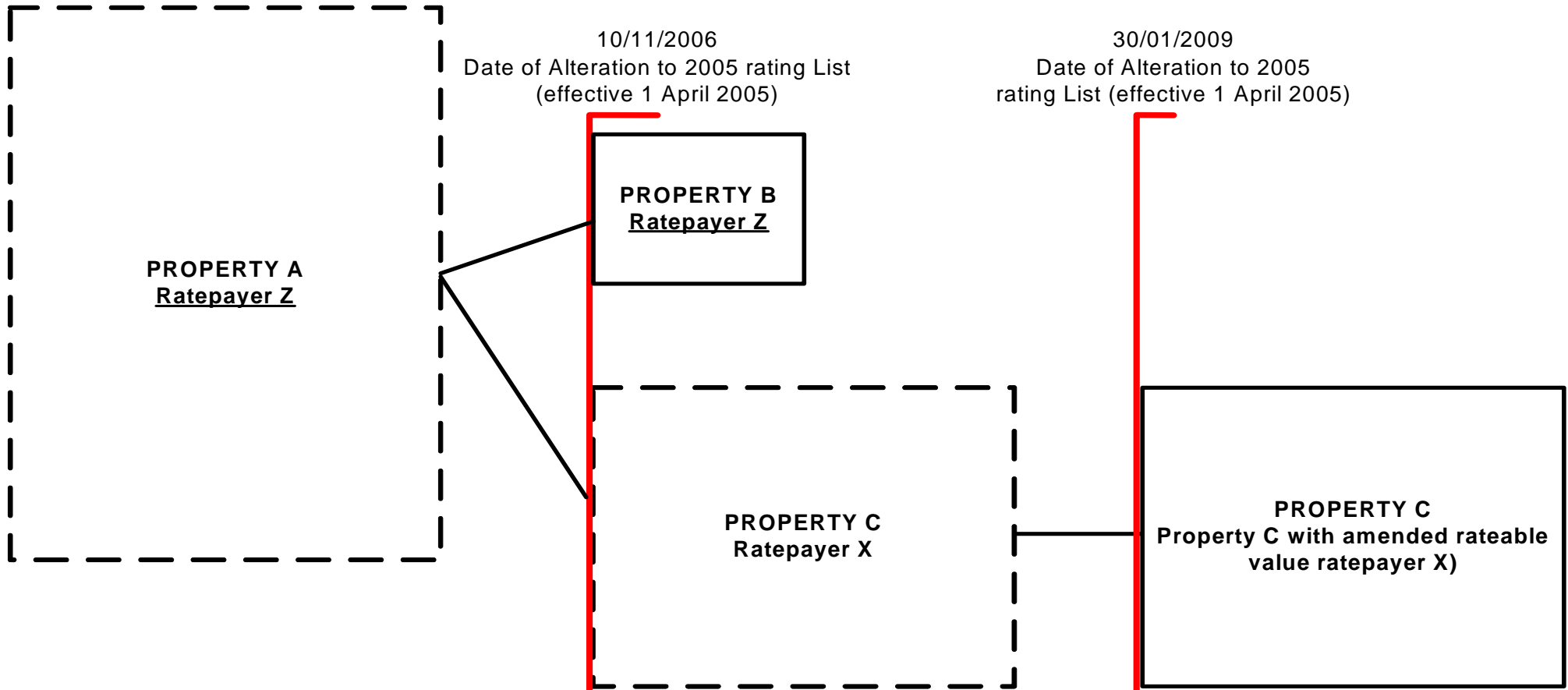

Ongoing Liability

Start of 2005 ratings list  
0/04/2005

33 Months since start of 2005 Ratings List  
01/01/2008

Final Date for Changes to List to Qualify for Waiver  
31/03/2010

## Scenario 17 - Answers to Questions

**Q1. Which properties are eligible for the waiver & why?**

A. None of the properties in this example are entitled to the waiver.

**Q2. What is the eligible period of backdated liability and why?**

A. N/A

**Q3. Which Property is not eligible for the waiver & why?**

A. Property B is not eligible for the waiver. This is because the ratepayer for Property B was the one responsible for the now deleted (original) property A from which Property B has been split. Property C is not entitled because we can see that although Property C was split from Property A, it did not meet the criteria as it did not incur a backdated rates bill of more than 33 months. Therefore none of the properties in this example would be entitled to a waiver.

# New Builds

New builds in themselves are not eligible for the waiver. However, as is the case with mergers, when combined with a split somewhere along the chain of alterations to the list, of any part of the same property, the eligibility criteria may be met. Some examples are set out below.

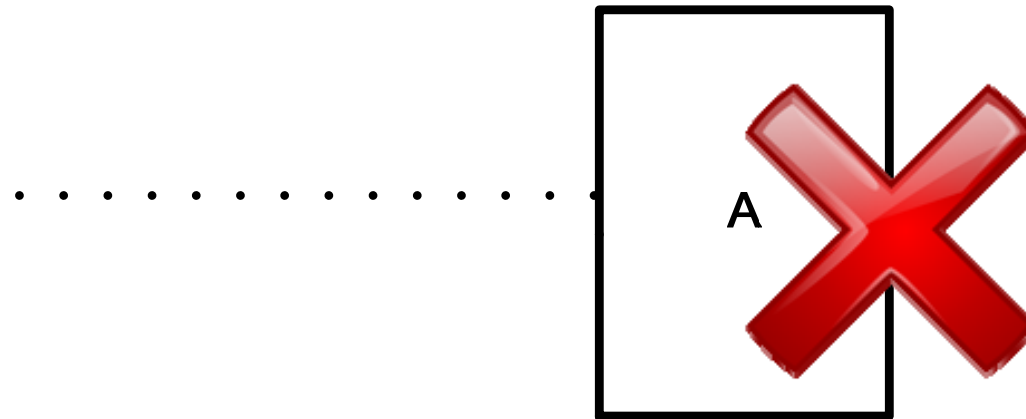

Scenario 18 - Simple New Build

31/01/2009  
Date of Alteration to 2005  
rating List (effective 27 Feb 2006)

**PROPERTY A  
New Build  
Ratepayer Y  
(Backdated to 27  
February 2006)**

**27/02/2006 - 31/01/2009  
PERIOD OF BACKDATED LIABILITY**

Start of 2005 ratings list  
01/04/2005

27/02/2006

33 Months since start  
of 2005 Ratings List  
01/01/2008

Final Date for Changes  
to List to Qualify for Waiver  
31/03/2010

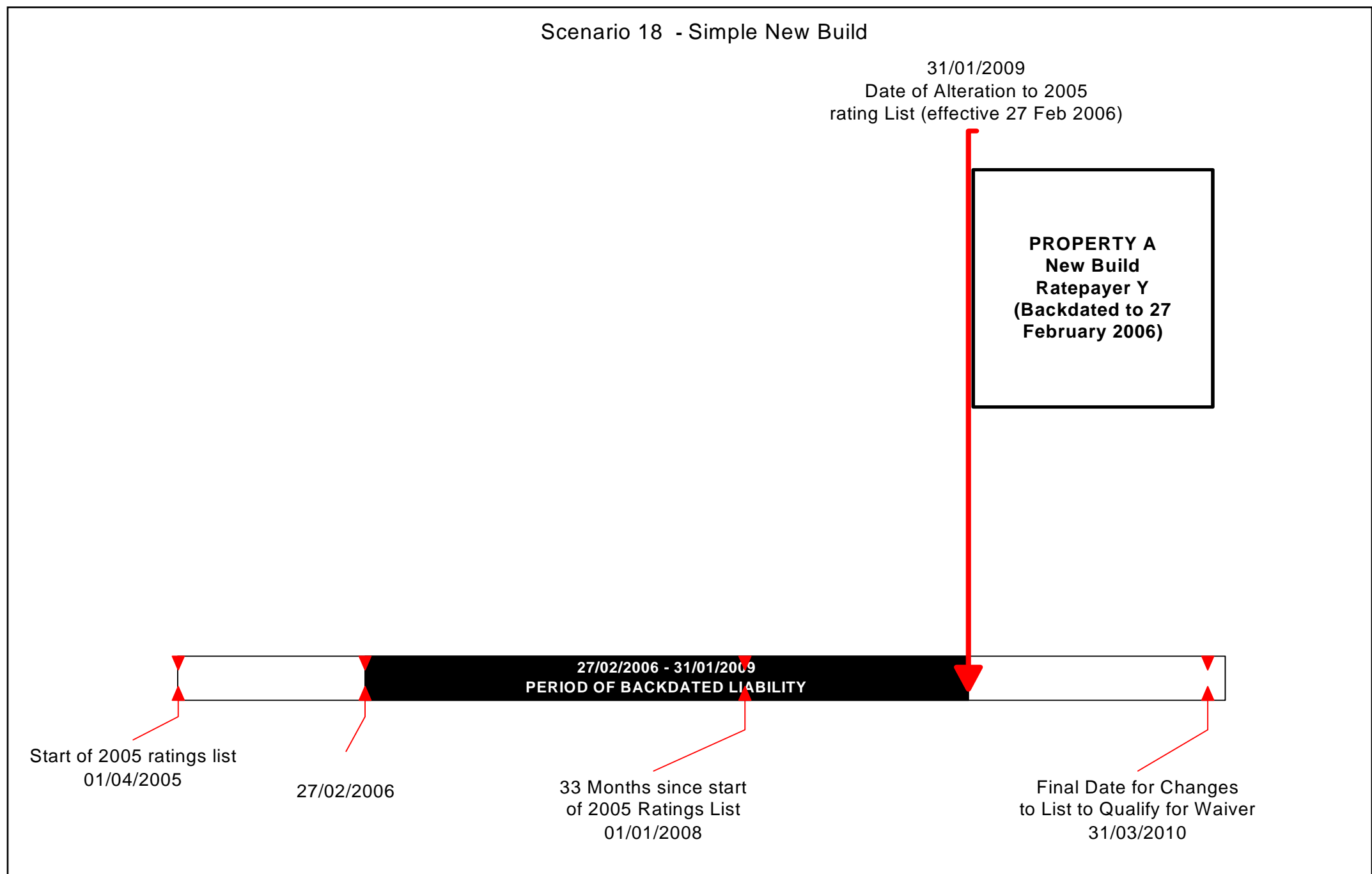

## Scenario 18 – Answers to Questions

**Q1. Which properties are eligible for the waiver & why?**

A. None – see answer to Q3

**Q2. What is the eligible period of backdated liability and why?**

A. N/A

**Q3. Which Property is not eligible for the waiver & why?**

A. There is only one property on the list in this scenario, Property A and this is not eligible for the waiver. Although Property has incurred a backdated liability of more than 33 months and the change was made before 31 March 2010, the property is a new build and the backdated liability did not occur because of a split. Therefore no waiver applied.

# New Builds & Splits

As illustrated in the example above, new builds in themselves are not eligible for the waiver. **However**, as is the case with mergers, when combined with a split somewhere along the chain of alterations to the list, of any part of the same property, the eligibility criteria may be met. Some examples are set out below.

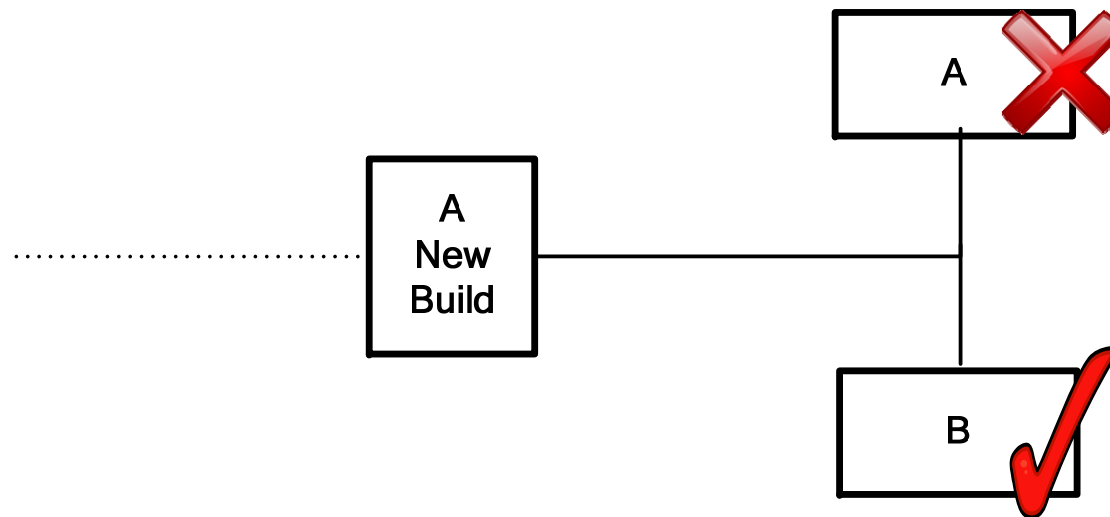



# Scenario 19 - Illustrated Examples of Backdated New Build

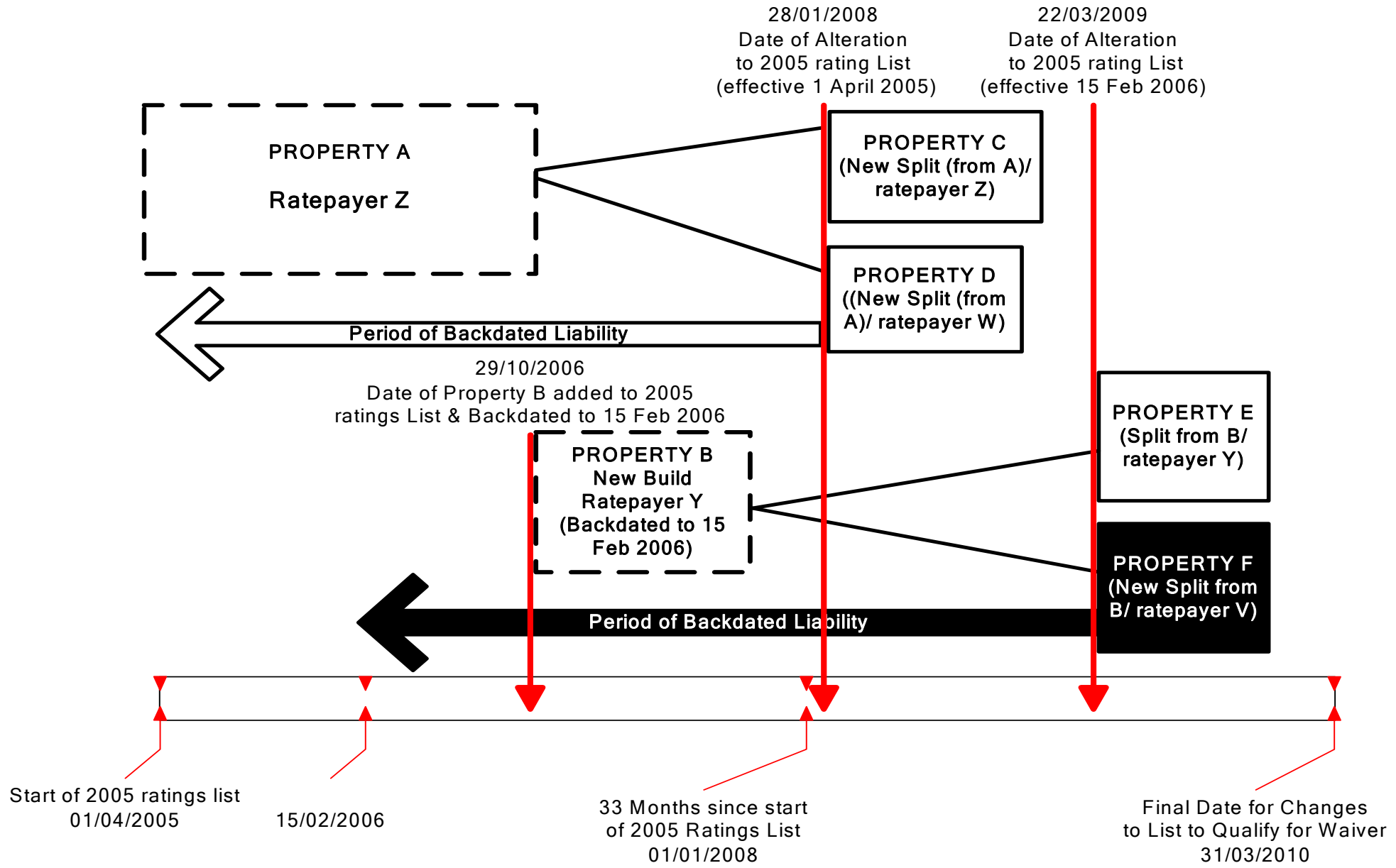

## Scenario 19 - Answers to Questions

### **Q1. Which properties are eligible for the waiver & why?**

- A. Properties D and F are eligible for the waiver. This is because they have both incurred a backdated liability of +33 months due to the properties being split from the assessment of another property and the ratepayers for both were not liable for rates on the properties within the 2005 rating list chain that led to the changes that created the respective properties.



### **Q2. What is the eligible period of backdated liability and why?**

- A. For Property D it is 1 April 2005 to 28 January 2008 because that was when it was inserted into the rating list. Property D is liable for ongoing rates from 29 January 2008. For property F it is 15 February 2006 to 22 March 2009.
- A. It only goes back to February 2006 because before that no one was liable for rates on that property and it ends on the date that Property F was added to the rating list. Property F is liable for ongoing rates from 23 March 2009.

### **Q3. Which Property is not eligible for the waiver & why?**

- A. Properties D and E are not eligible for the waiver. This is because the ratepayer for both were also responsible for the predecessor hereditaments (and neither of the predecessor hereditaments were eligible therefore there is no transfer of eligibility either).

## Diagram Key

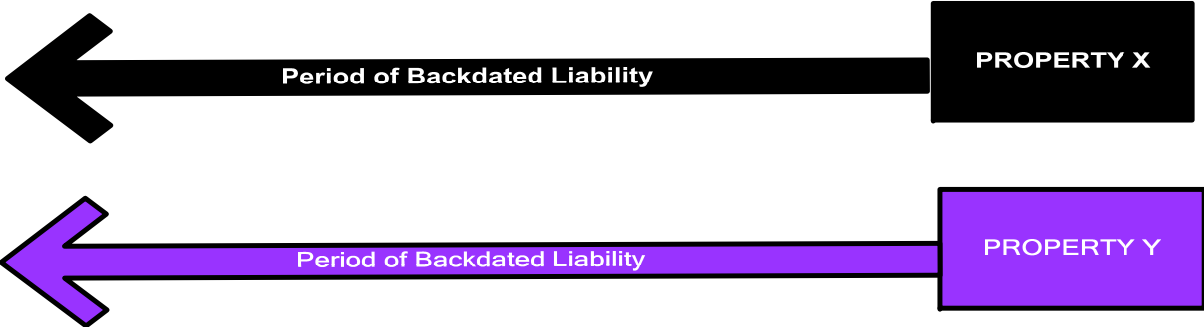
<p>Boxes in dotted lines represent deleted properties</p>	
<p>Boxes without dotted lines represent properties on the rating list</p>	
<p>Coloured arrows (black or purple, represent the period of backdated liability for the property represented by the same colour in the diagram.</p>	
<p>Shaded areas in the timeline box represent period of backdated liability</p>	