



Key features:

- Five seat helicopter used for light transport, training and light attack duties
- Minimal maintenance and low running costs

The Gazelle is used by approximately 23 countries, primarily for surveillance and reconnaissance. It is also used in applications such as attack, anti-tank, anti-helicopter, transport and training. Advantages include its small agile nature with lightweight chassis and its unparalleled visibility from the cockpit. While many helicopters struggled with the extreme conditions of the Afghan and Iraqi theatres, the Gazelle was the best performing model amongst British aircraft. It can accommodate 1 pilot and 4 passengers and up to 600kg of cargo on the underside cargo hook.

Length	11.97m
Width	9.94m
Rotor Diameter	10.50m
Capacity	5 seats
Max Take-off Weight	1800kg

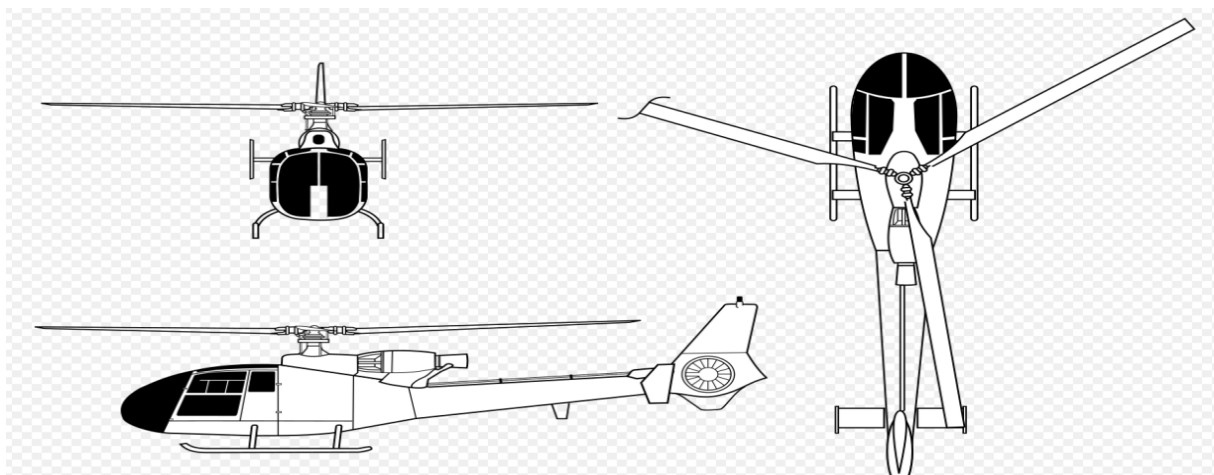

DEFENCE EQUIPMENT SALES AUTHORITY

Power plant	1 × Turbomeca Astazou IIIA turboshaft, 440 kW
Crew	1 or 2
Main Rotor Area	86.5m ²
Empty Weight	917kg
Maximum Speed	311km/h sea level
Cruise Speed	264km/h sea level
Rate of climb	9 m/s
Range	710km



Contains public sector information licensed under the Open Government Licence v3.0. All images are MOD Crown Copyright 2021