

1.13T GS CARGO

DEFENCE EQUIPMENT SALES AUTHORITY

TRL LIGHT WEIGHT

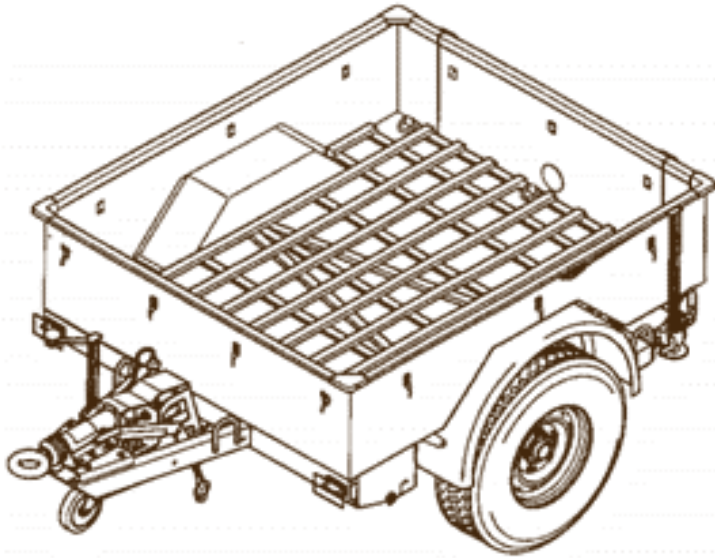

Key features:

- Six Load Securing Shackles
- Hydraulically Operated Disc Brakes
- Steel Chassis
- Stainless Steel Cargo Body
- Hinged Tailgate

Trailer Light Weight GS is used for transporting cargo loads of up to 1130kg (1.13 ton). The trailer is designed to be towed by a variety of utility vehicles.

Fully laden the Trailer Light Weight GS can be towed at a max speed of 80kph / 50mph.

With the ability to be transported by a variety of Land Vehicles or by Air, these robust trailers can be operated in harsh environments worldwide.

Dimension	Metres
Max Length	2.8m
Max Width	1.8m
Max Height	1.115m
Ground Clearance	0.345m

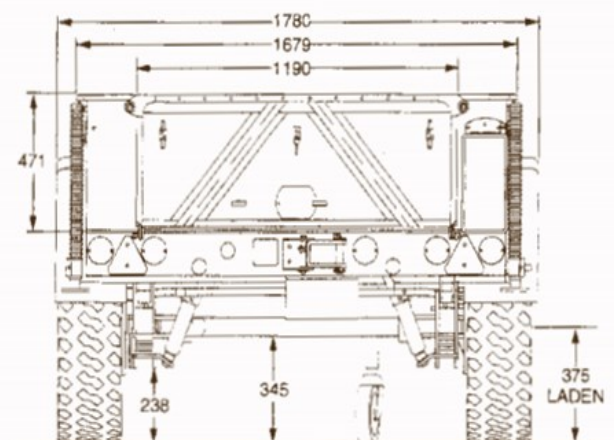
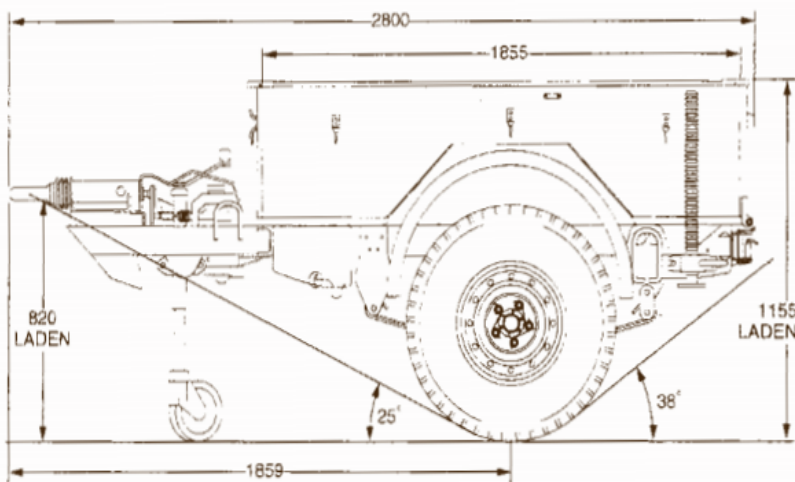

1.13T GS CARGO

DEFENCE EQUIPMENT SALES AUTHORITY

TRL LIGHT WEIGHT

Unladen Weight	620kg
Laden Weight	1750kg
Height	1.2m
Max Road Speed	80kph/ 50mph
Average Range	12000km per year
Operating Range	-40°C to +49°C
Fording Depth	1.5m
Door Width	1.19m
Opening Range	180°
Internal Dimensions	Length: 1.85, Width: 1.6m, Depth: 0.47m
External Dimensions	Length: 2.8, Width: 1.8m
Brakes	Disc
Tyres	7.5 OR16 XZL Michelin Tyre
Suspension	Elliptical Springs, Telescopic Shock Absorbers

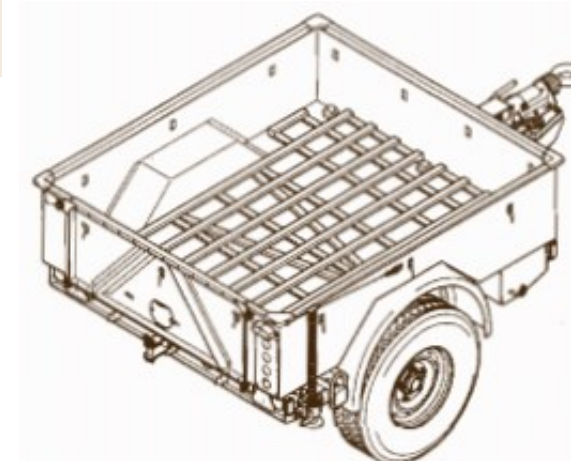
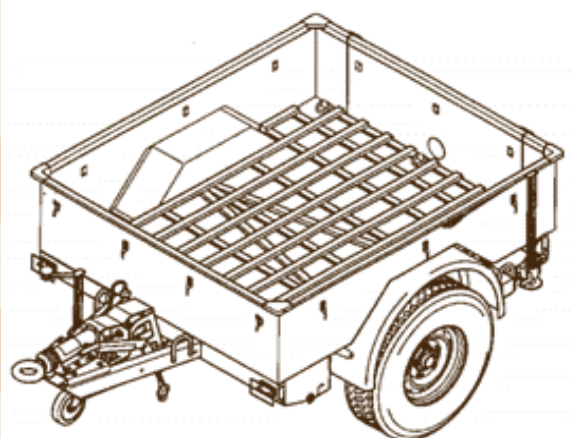

Whilst every care has been taken to ensure the information provided is accurate, up-to-date and complete, neither the UK MOD nor any of its representatives accept any liability for any errors or omissions in the information. It is stressed that the information provided is not and will not be a contractual statement of the condition or quantity of items. No guarantee of the accuracy is either given or implied. This asset is subject to availability. The UK MoD reserves the right to withdraw this asset from the market. The UK MOD reserves the right to modify or upgrade this asset without notice. This asset is considered specially designed for military use.

Contains public sector information licensed under the Open Government Licence v3.0. All images are MOD Crown Copyright 2021.