

Industry's Draft Technical Specifications

08 August 2011

Table of Contents

Table of Contents	2
Acknowledgements	3
Overview	4
The Scope of the Functional Requirements.....	5
The Great Britain (GB) Perspective	6
Process and Relationship with other Papers and Industry	7
Base Meters.....	9
Electricity Meters.....	9
Three Phase Meters	10
Electricity Meter Variants.....	13
Polyphase meters	26
Gas meters	30
Architectures	32
Extended Functional Requirements	50
Security	188
Security assumptions.....	194
Security Requirements	195
Appendix A: Glossary	222
Appendix B: Normative References	238
Appendix C: HAN Evaluation Criteria	264
Appendix D: Events Table.....	279

Acknowledgements

1.1. This document was drafted by industry, stakeholders under the Smart Metering Design Group (SMDG) set up under the Great Britain (GB) Smart Metering implementation programme (SMIP).

1.2. Throughout the 6 month period of Technical Specification development over 150 representatives of industry stakeholder groups have participated in the development of this document. Organisations and their respective number of participants is shown in the Table 1 below.

Table 1 – Number of representatives from each industry stakeholder group that participated in developing the Technical Specification

Company	Number of participants
Association of Meter Operators (AMO)	9
British Electrotechnical and Allied Manufacturers Association (BEAMA)	13
British Gas	7
Consumer Focus	3
EDF Energy	16
Energy Networks Association (ENA)	7
Energy Retail Association (ERA)	6
EON UK	10
Energy Services and Technology Association (ESTA)	9
First Utility	5
Gemserv	5
Good energy	1
I&C Shippers and Suppliers (ICoSS)	5
Intellect	19
Ofcom	2
RWE npower	11
Society of the British Gas Industries (SBGI)	16
ScottishPower	11
Scottish and Southern Energy (SSE)	12
Utilita	4
Other	
The Application Home Initiative (TAHI)	2
Technology Strategy Board (Astutim)	2
Electralink	2
Xoserve	2
Total	179

Overview

1.3. One hundred and fifteen (115) functional requirements were presented in the Functional Requirements Catalogue ("The Catalogue"), published alongside the Prospectus (July 2010). The functional requirements were confirmed in the Response Document published in March 2011.

1.4. The Catalogue identified those functional requirements which were considered applicable to domestic, non-domestic or both sectors and categorised functions in logical sections. This document, the Industry Extended Statement of Design Requirements (ESoDR), with its appendices, takes the requirements within The Catalogue published in March 2011 and defines, in more detail, the minimum requirements of the Smart Metering equipment to be fitted.

1.5. The Catalogue was reviewed through the Working Groups (WG) created under the Smart Meter Design Group (SMDG) and a final review process in July 2011. The review of the functional requirements has created a more detailed version that has allowed the production of this document, the Industry Extended Statement of Design Requirements (ESoDR).

1.6. This document forms part of a set of documents designed to describe, in detail, the requirements for domestic and smaller non-domestic Smart Metering equipment in Great Britain.

The Scope of the Functional Requirements

1.7. The functional requirements are generally a description of what the Smart Metering equipment must deliver. They do not specify how functions will be delivered. As such, multiple solutions may be possible using a variety of components.

Figure 1 - Scope of Functional Requirements

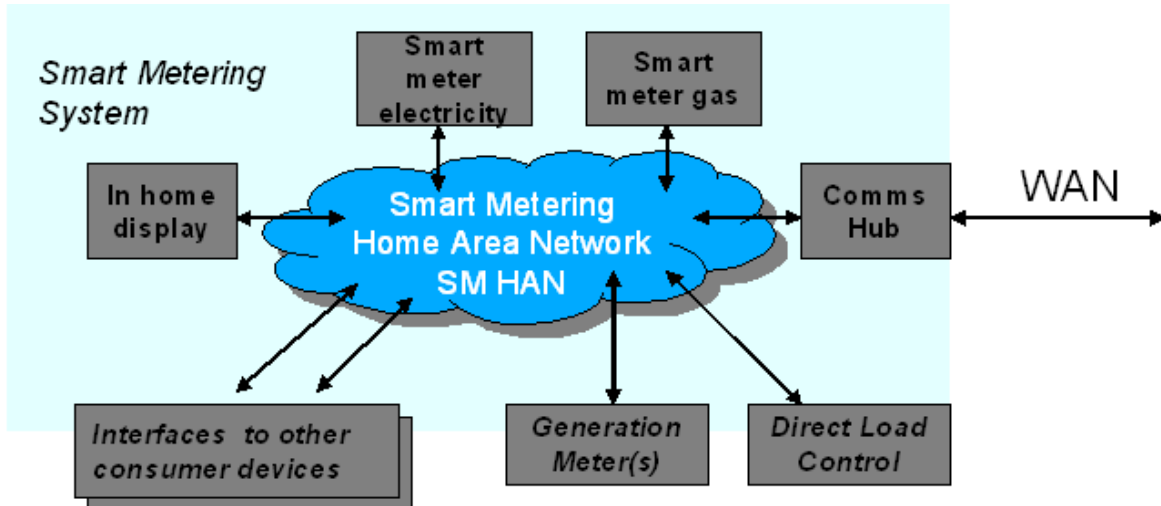

1.8. The scope of The Catalogue covered the Smart Metering equipment and associated communication interfaces. Figure 1 represents an architecture similar to that published in The Response (March 2011). This is not intended to define any particular architecture. Smart Metering equipment architecture is described in full in the Architectures supporting document. Extracts from that document are included in the “Architectures” section of this document.

1.9. The Smart Metering System (SMS) includes the key Smart Metering equipment components of Meters, Communications Hub and In Home Display (IHD) and these are interconnected by the Smart Metering Home Area Network (SM HAN) which is denoted by the blue rectangle in Figure 1.

1.10. Other components, not covered in the scope of this document (shown on the edge of the blue area in Figure 1) may derive information from, or provide information to the SM HAN, either directly or indirectly. These are described as “other consumer devices” (e.g. hot water storage, fridges/freezers, washing machines etc.) “Generation Meter(s)” (e.g. Feed In Tariff Meters) or “Direct Load Control” (e.g. Economy 7 storage heating loads).

1.11. There are no functional requirements for the items mentioned in paragraph. 1.9, in the ESoDR. However, data items to allow communication with the SM HAN will be specified at a later date.

1.12. This ESoDR provides a set of minimum functional requirements for the required Smart Metering System equipment. It is expected that this document will be developed further into detailed design specifications by metering, communications and display equipment manufacturers. Close attention must be paid to the need for ensuring interoperability in developing the further detail.

The Great Britain (GB) Perspective

1.13. It is internationally recognised that the GB competitive retail energy market is unique and therefore has many requirements and practices not seen in other energy markets.

1.14. The easily identifiable differences are listed here:

- The Supplier Hub Principle (See Figure 2)
- The energy supplier holds the contract with the consumer and is central to the provision of services, including metering, to provide energy and peripheral services to the consumer.

Figure 2 – Supplier Hub Principle

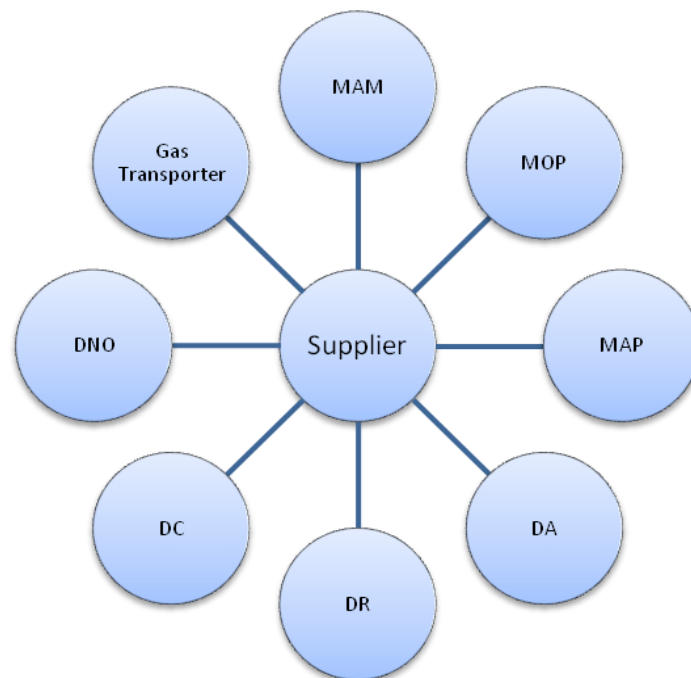

Where:

- MAM = Meter Asset Management
- DR = Data Retrieval
- DA = Data Aggregation
- DC = Data Collection
- DNO = Distribution Network Operator
- MOP = Meter Operator
- MAP = Meter Asset Provider
- A large proportion of prepayment consumers:
 - Who are provided with emergency credit arrangements
 - Who are provided with socially acceptable friendly disconnect periods
 - Who will have their supply disabled for insufficient payment for energy.
- Network Operators are not responsible for metering services.
- Demand side load management provision using Load Switches within the meter in significant numbers of installation.
- An Electricity meter terminal arrangement specific to Great Britain.

Process and Relationship with other Papers and Industry

Figure 3 - Relationship between SMDG Delivered Papers and Industry

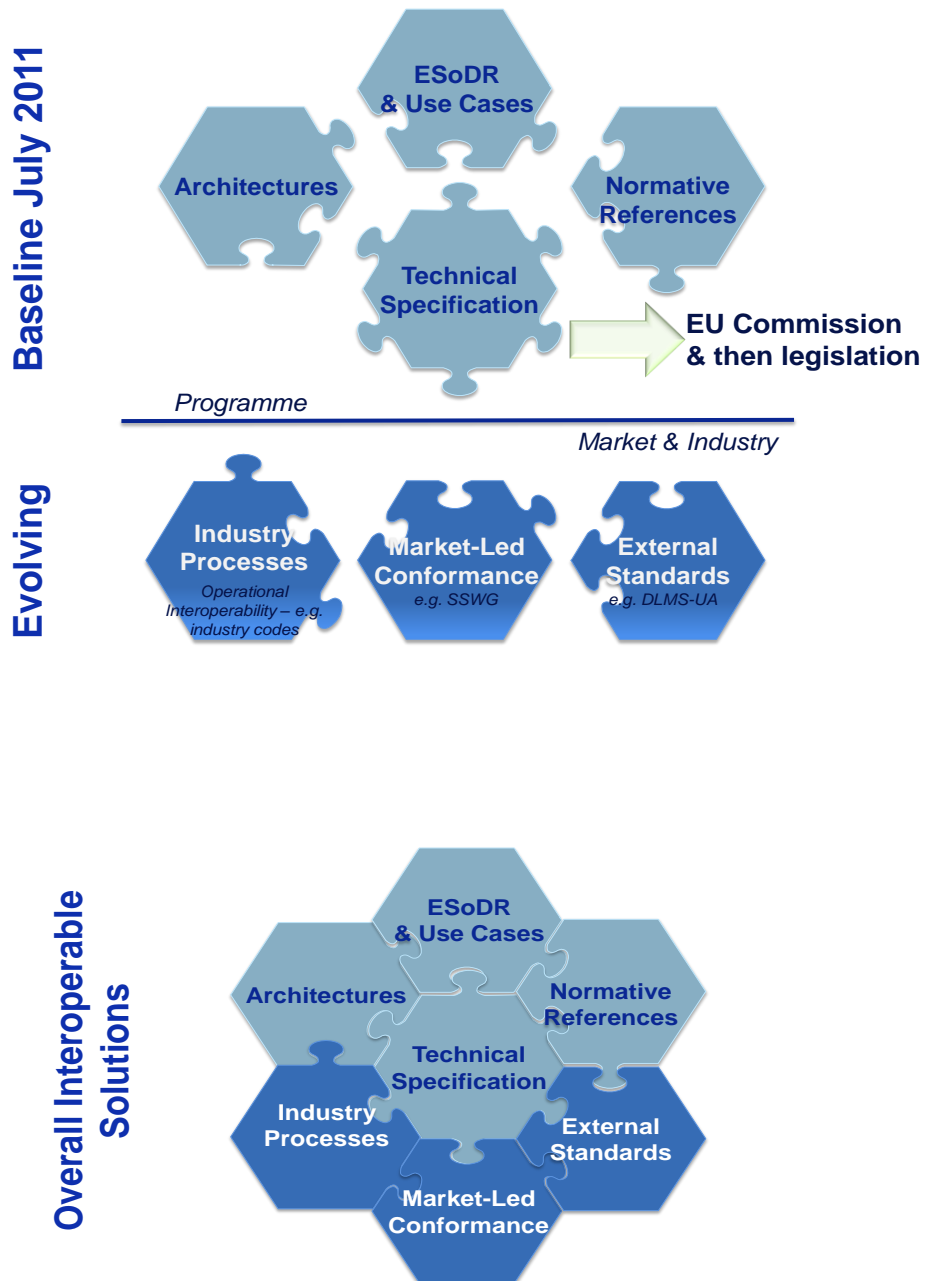

1.15. The Industry Extended Statement of Design Requirements (ESoDR), coupled with the Use cases, Architectures and Normative references are designed to give sufficient information to

manufacturers of Smart Metering Systems components and energy suppliers to give them confidence in moving forward.

1.16. Throughout the consultation process for Smart Metering has been referred to as the “Technical Specification” and is shown in the upper half of Figure 3 below:

1.17. These documents will be used to form the basis of the submission of the GB Smart Metering program: technical specification to the European Commission for formal notification under the Technical Standards Directive (98/34).

1.18. As the respective parts of the market merge technically and commercially interoperable products will be available.

1.19. In parallel to the work being undertaken by the DECC programme, commercial organisations can take this documentation and collaborate to provide technically interoperable solutions to deliver the Smart Metering requirements. In this situation collaborating manufacturers of components could derive interoperability by defining communications protocols and the interfaces between components. Such groups would need to provide a metering system which met all the functional requirements of this document.

1.20. Where organisations collaborate to provide a technically interoperable solutions they must use open and non proprietary standards. The following European definition of Openness must be met:

- All stakeholders have the same possibility of contributing to the development of the specification, and public review is part of the decision-making process
- The specifications are available for everybody to study
- Intellectual property rights related to the specification are licensed on Fair, Reasonable and Non-Discriminatory (FRAND) terms, or on a royalty-free basis in a way that allows implementation in both proprietary and open source software.

Base Meters

1.21. To add clarity to the meter requirements in the SMS base assumptions for Electricity and Gas meter have been added here.

Electricity Meters

1.22. The base electricity Smart Meter shall conform to GB industry requirements and standards in terms of basic functionality.

Single Phase 2 Wire Electricity Meter Ratings

1.23. The meter shall (as shown in Figure 4) comply with the relevant standards for a 230 Volt; 100 Ampere; 50 Hertz meter of MID accuracy class B or better.

1.24. For Operational purposes the meter shall be:

- Capable of sustaining a continuous current of 120A for long periods;
- Fitted with an internal main Load Switch suitable for prepayment and load limiting purposes rated to make on fault current and safely break load currents of up to 120A.

1.25. The meter shall calculate and transmit to the Smart Metering HAN (SM HAN) the values necessary to provide display values in accordance with the requirements of IH.02.

1.26. For ambient display of electrical energy consumption on minimum specification IHDs, remotely configurable Low/Medium/High thresholds will be provided as follows:

- Low < X kW
 - Medium >X <Y kW
 - High > Y kW
- Where X (Low Power Threshold) and Y (High Power Threshold) are configurable instantaneous power values in kW to 2 decimal places (ranging from 0 to 23 kW)

1.27. The calculation of Low, Medium and High values will take place every 10 seconds (or better).

1.28. The meter shall transmit the values to the IHD to give a near real time indication of energy consumption.

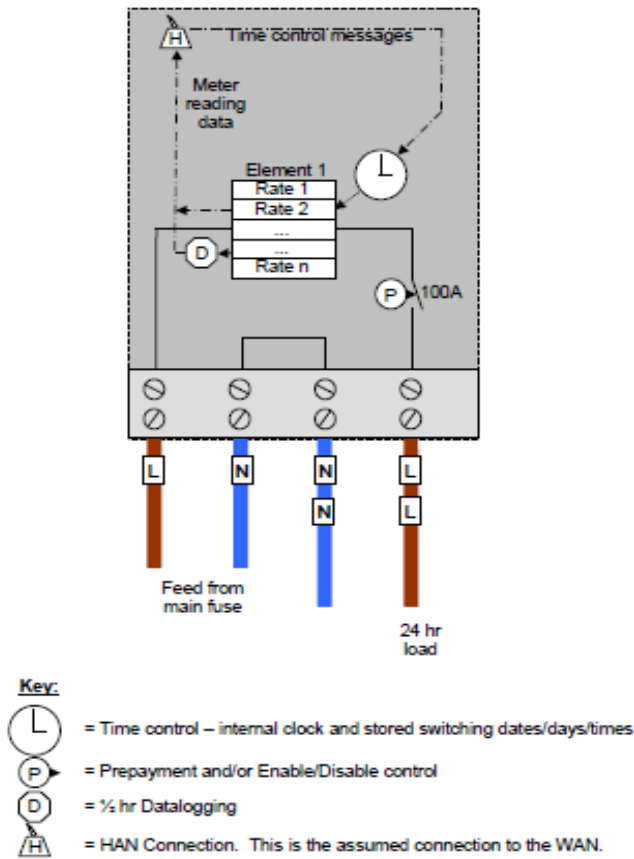
Figure 4 – Single Phase Base Meter

Three Phase Meters

Three Phase Three Wire Ratings

1.29. The meter shall (as shown in Figure 5):

- Comply with the relevant standards for a 3x230 Volt; 3x100 Ampere; 50 Hertz meter of MID accuracy class B or better;
- Be capable of operating accurately when connected to 2 phases of a 3 phase 4 wire supply (i.e. 2 phases 120° apart 230V/400V);
- Be capable of operating accurately when connected to a 1 phase 3 or 4 wire supply (i.e. 2 or 3 live lines derived from the same phase source. Sometimes referred to as summation mode);
- Be capable of arithmetically summing individual phase import and export kW/kWh/kVAr/kvarh values to produce nett values (e.g. import 3kW on phase L1, export 1kW on L3, nett is 2kW import (0 kW export)).

Note: The purchaser may specify that the meter shall also be suitable (approved and tested) for connections to a 1 phase 3 wire supply (derived from a single phase HV system, 2 phases 180°).

1.30. For operational purposes the Smart Meter shall:

- Be capable of sustaining a continuous current of 120A applied simultaneously to all 3 phases for long periods;

- Have an internal main three phase, 3 wire Load Switch suitable for prepayment and load limiting purposes rated to make on fault current and break up to 120A applied to all three phases simultaneously;
- Have an internal main three phase Load Switch wherein all contacts operate simultaneously on making and breaking operations;
- Have three separate phase indicators which indicate and identify any one or more disconnected supply lines (e.g. service fuse ruptured, etc.).

Figure 5 – Three Phase Base Meter

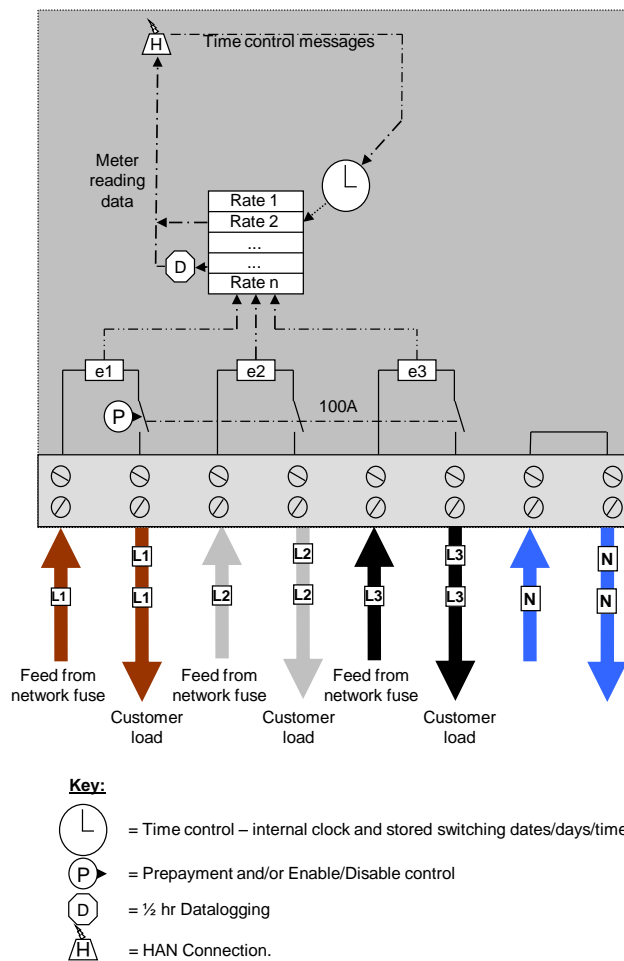

General Construction/Design Features

1.31. The Smart Meter including its internal Load Switch, and where appropriate, Communications Hub shall conform to Normative References in terms of:

- Accuracy;

- Protective Class;
- IP Rating;
- Sealing;
- Influencing Quantities;
- Short Circuit Protection;
- Labelling and connection diagram.

1.32. Additionally the Smart Meter shall:

- Feature a visual indicator for the purpose of time/power accuracy testing;
- Have a minimum product design life of 20 years;
- Feature restoration requirements designed to overcome surge induced micro-processor freezing events (i.e. watchdog measures);
- Have a battery which will keep the internal clock functioning for a minimum of 24 months when the meter is not on supply (i.e. to cover shelf life and loss of supply when meter is in service);
- Retain any static data indefinitely whilst off supply;
- Have significant characters (e.g. digits in rate register readings) that, as a minimum meet the requirements of BSEN 50470;
- Be configurable to allow the supplier or his agent to determine which registers and other data may be displayed to the customer;
- Be configurable to “auto-cycle” through the displays, at a configurable frequency, or to be manually stepped through;
- Have a display integrity check;
- Meet all required EMC standards and additionally shall feature immunity to noise in the 3 to 150kHz range;
- Feature a minimum of two push buttons to provide the means for local prepayment credit entry, physical interaction to restore supply and manual display cycling by the customer;
- Feature an audible sounder that can be configured to acknowledge push button operation.

Markings

1.33. The Smart Meter shall have a nameplate with detail as required by the MID, i.e.:

- Manufacturer;
- Serial Number + barcode form;
- Voltage rating;
- Current rating;
- Number of phases;
- Manufacturers type reference;
- Year of manufacture;
- CE Mark;
- Battery Details;
- WEEE Markings.

Smart Meter HAN (SM HAN) Connectivity

1.34. The base Smart Electricity Meter shall be capable of transmitting price related information across the SM HAN related to differing tariff rates for use by IHDs and smart appliances. To facilitate this requirement it will be necessary for the meter to contain a configurable table that aligns current price with current tariff rate.

1.35. The base Smart Electricity Meter shall be capable of transmitting on/off commands to SM HAN enabled switches and contactors. To facilitate this requirement it will be necessary for the meter to contain a configurable table that allows for switching commands to be aligned with start and finishing times of selected tariff rates.

Normative references

- BS EN 62053-21, Electricity metering equipment (a.c.). Particular requirements. Static meters for active energy (classes 1 and 2).
- BS EN 50470-1:2006 Electricity metering equipment (a.c.). General requirements, tests and test conditions. Metering equipment (class indexes A, B and C).
- BS EN 50470-3:2006 Electricity metering equipment (a.c.). Particular requirements. Static meters for active energy (class indexes A, B and C).
- BS EN 62052-11 Electricity metering equipment (AC) - General requirements, tests and test conditions - Part 11: Metering equipment.
- BS EN 62055-31 Electricity metering. Payments systems. Particular requirements. Static payment meters for active energy (classes 1 and 2).
- Smart Meters in that they are required to perform a prepayment meter function clearly need to be governed by a pre-payment meter standard. However at present the only standard available is BS EN 62055-31, this in its current form only relates to meters of accuracy class 1 & 2. Clearly this standard needs to be updated to reflect measurement classes arising from the MID i.e. classes A, B and possibly C. It is assumed that BSi will, in time, be undertaking this task.
- BS EN 60947-3 Low-voltage switchgear and controlgear. Switches, disconnectors, switch-disconnectors and fuse-combination units.

Security Requirements

1.36. General Construction/Design Features need to take account of the possibility that unscrupulous customers might look to reset meter registers by means of high voltage discharge devices such as gas igniters. Accordingly the design of the meter needs to provide shielding which is able to protect any vulnerable component from such attack.

1.37. Meters are likely to be installed in locations where they will be vulnerable to a variety of Security risks. This includes risks that may also occur from the Meters' wider connection to the WAN and SM HAN. All Meters should therefore comply with the Security Requirements set down in the ESoDR. Security must also be considered during the design, implementation and testing of Meters.

Electricity Meter Variants

1.38. The Electricity Meter Variants Group (EMVG) has considered the needs of legacy metering requirements to meet the needs of consumers on preserved tariffs.

1.39. The work in detail, carried out within the Programme, can be seen in the supporting document "Meter Variants Options Paper Ref: EMVWG.02".

1.40. The following single (Table 2) and polyphase variants (Table 3) are proposed below.

Single Phase 2 Wire Variants

Table 2 - Single Phase 2 Wire Variants

Variant Reference	Description	Integral OP ¹ 100A Contactor	Integral OP6 25A Contactor No 1	Integral OP6 25A Contactor No 2	"Clean" OP6 25A Contactor	Relay 1	Relay 2
S1 (Figure 6)	1 element meter + Rly					✓	
S2 (Figure 7)	1 element meter + integral 100A OP6	✓					
S2a (Figure 8)	1 element meter + integral 100A OP6 + Rly	✓				✓	
S3 (Figure 9)	1 element meter + integral 100A + 25A OP6	✓	✓				
S3a (Figure 10)	1 element meter + integral 100A + 25A "clean" OP6	✓			✓		
S4 (Figure 11)	2 element meter + integral 100A OP6	✓					
S5 (Figure 12)	2 element meter + integral 100A + 25A OP6	✓	✓				
S5a (Figure 13)	2 element meter + integral 100A + 25A "clean" OP6	✓			✓		
S5b (Figure 14)	2 element meter + integral 100A + 25A OP6 + Rly	✓			✓	✓	
S5c (Figure 15)	2 element meter + integral 100A + 2 off 25A OP6	✓	✓	✓			

¹ OP - Off Peak

1.41. Single Phase 2 Wire Notes:

- All variants are expected to meet all of the electricity meter ESoDR requirements, in addition to the variant requirements contained herein.
- All variants assume the same element rating as the base meter (e.g. 100A or as determined by Expanded Statement of Design Requirements).
- This list was based on the original list accepted in principle by Ofgem's SMDG SM3 group. The list was updated following feedback from meter operators in response to EMV WG's questionnaire. In particular variant, S3a, S5a and S5c have been added.
- Export measurement is only required on the first element. It is not required for the second element of 2 element variants, as it would not be sensible for customers to attempt export through an interrupted supply. (e.g. ES.03 and ES.07 need not apply).
- For avoidance of doubt, ES.04, ES.05, ES.08, ES.09 shall apply to the second element of 2 element variants.
- The layouts shown for the additional terminals are indicative only (BS7856 is expected to apply to the base meter).
- Internal contact and relay ratings shown are indicative.
- The data flows shown are for an explanation of the basic operation of the meter function with regard to rate and Load Switch control only. For instance credit transfer to the prepayment function via the HAN, and pricing and reading information to the IHD have not been shown. When in prepayment mode the meter logic will open all contacts when credit is exhausted (including 2 element meters), according to whatever prepayment rules have been applied (e.g. does not switch OFF during "No Night Time disconnect" periods). Similarly if the meter is disabled, all contacts will open.

Figure 6 – Single Phase 2 wire variant S1 1 Element Meter with 2A Relay for External Contactor Load Control

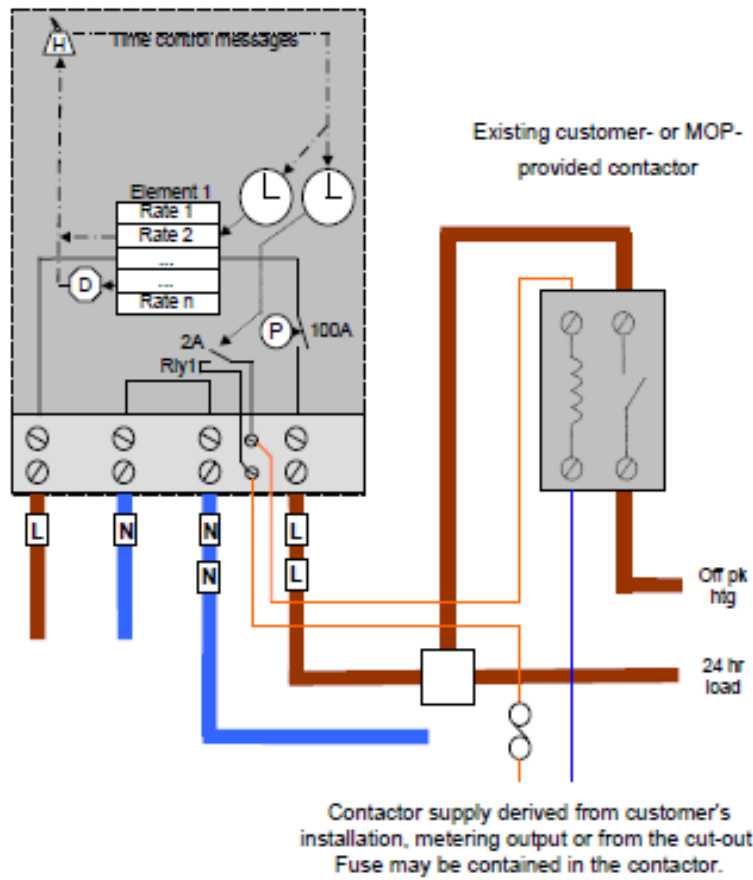

Notes:

- 1 Rly1 is typically programmed to control the off peak load coincident with the night rate register via an external contactor.

Figure 7 – Single Phase 2 wire variant S2 1 Element Meter with Integral Off Peak Load Control Switching

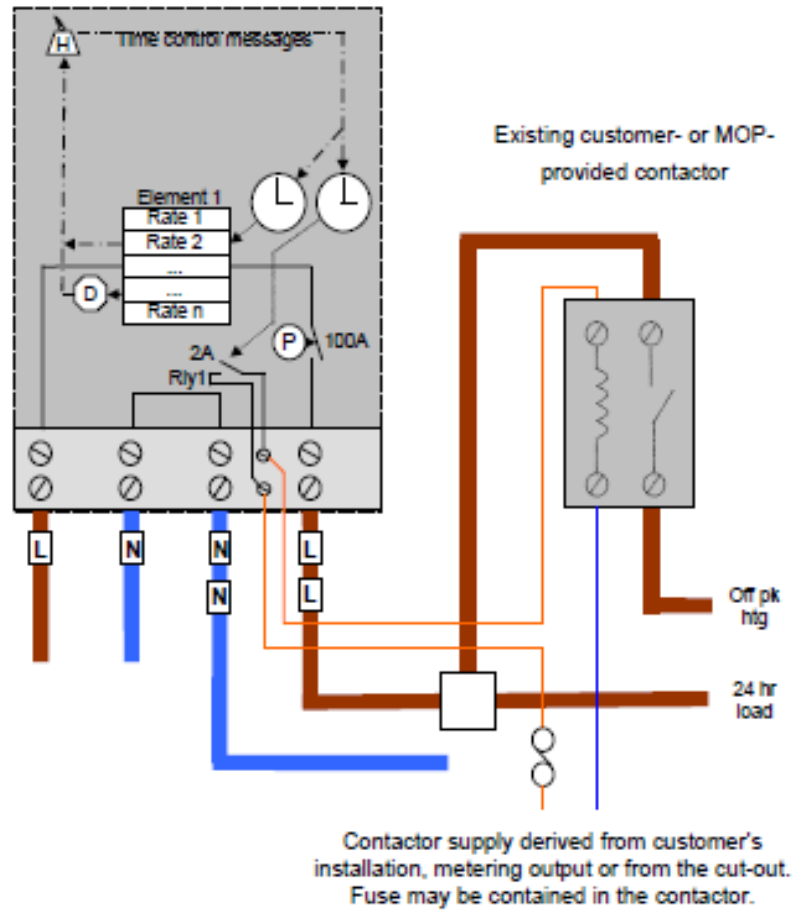

Notes:

- 1 Rly1 is typically programmed to control the off peak load coincident with the night rate register via an external contactor.

Figure 8 – Single Phase 2 wire variant S2a 1 Element Meter with Off Peak Load Control Switching and Separate 2A Relay for Alternative External Contactor Load Control

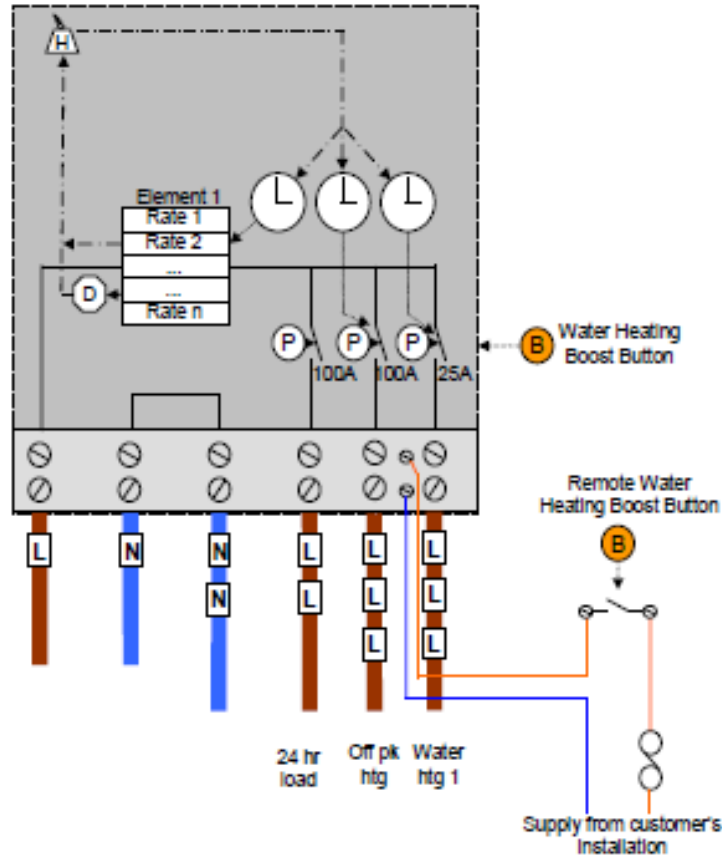

Notes:

- 1 The second 100A contact is typically programmed to control the off peak load coincident with the night rate register.
- 2 The 25A contact may close for different (reduced) times.
- 3 The meter to have button and/or connection for remote button to boost the water heating, ie manually add 1 or 2 hrs charge. The remote connection to be as existing. This function to be configurable.

Figure 9 – Single Phase 2 wire variant S3 1 Element Meter with Off Peak and Water Heating Load Control Switching

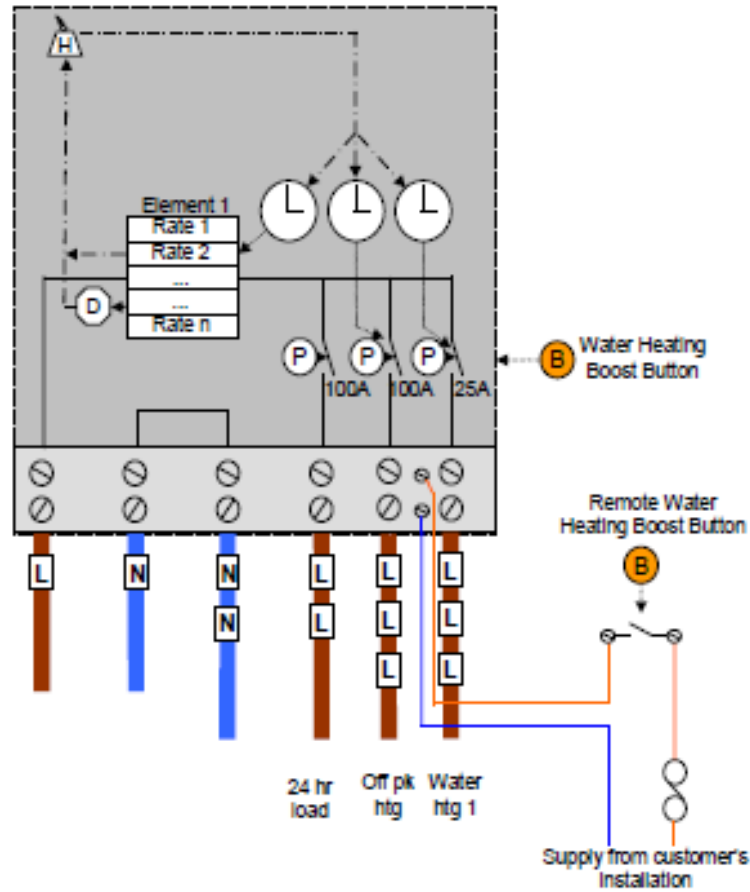

Notes:

- 1 The second 100A contact is typically programmed to control the off peak load coincident with the night rate register.
- 2 The 25A contact may close for different (reduced) times.
- 3 The meter to have button and/or connection for remote button to boost the water heating, ie manually add 1 or 2 hrs charge. The remote connection to be as existing. This function to be configurable.

Figure 10 – Single Phase 2 wire variant S3a 1 Element Meter with Off Peak and Water Heating (“clean” contact) Load Control Switching

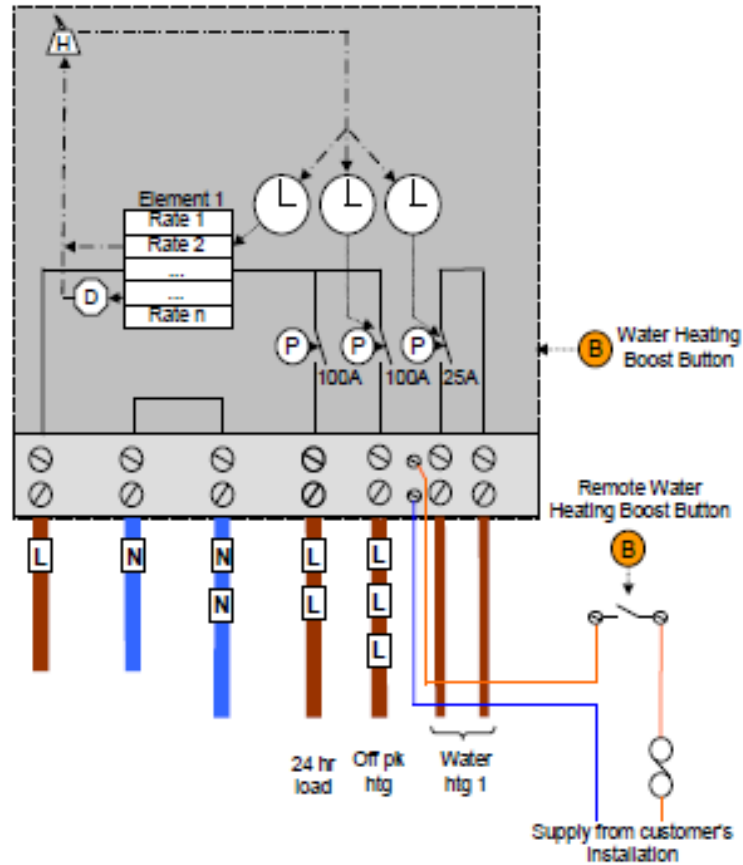

Notes:

- 1 The second 100A contact is typically programmed to control the off peak load coincident with the night rate register
- 2 The 25A contact may close for different (reduced) times. The 25A contact is typically wired into the customer's final water heating sub-circuit.
- 3 The meter to have button and/or connection for remote button to boost the water heating, ie manually add 1 or 2 hrs charge. The remote connection to be as existing. This function to be configurable.

Figure 11 – Single Phase 2 wire variant S4 2 Element Meter with Off Peak load Control Switching

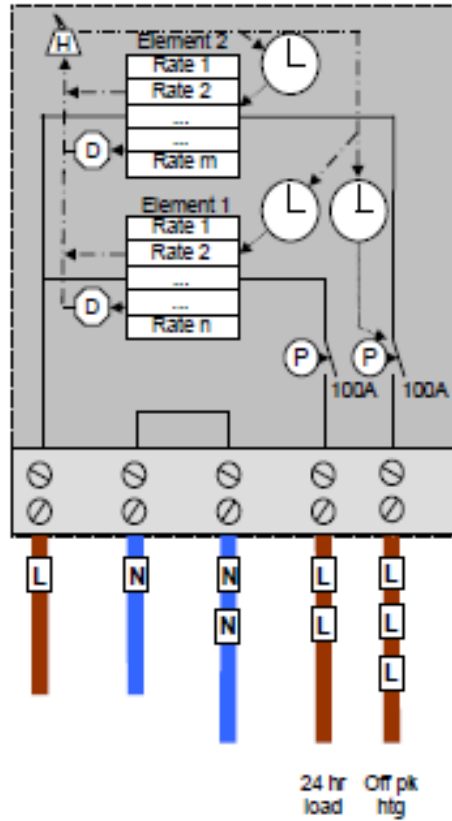

Notes:

- 1 The second 100A contact is typically programmed to control the off peak load coincident with the night rate register.

Figure 12 – Single Phase 2 wire variant S5 2 Element Meter with Off Peak and Water Heating Load Control Switching

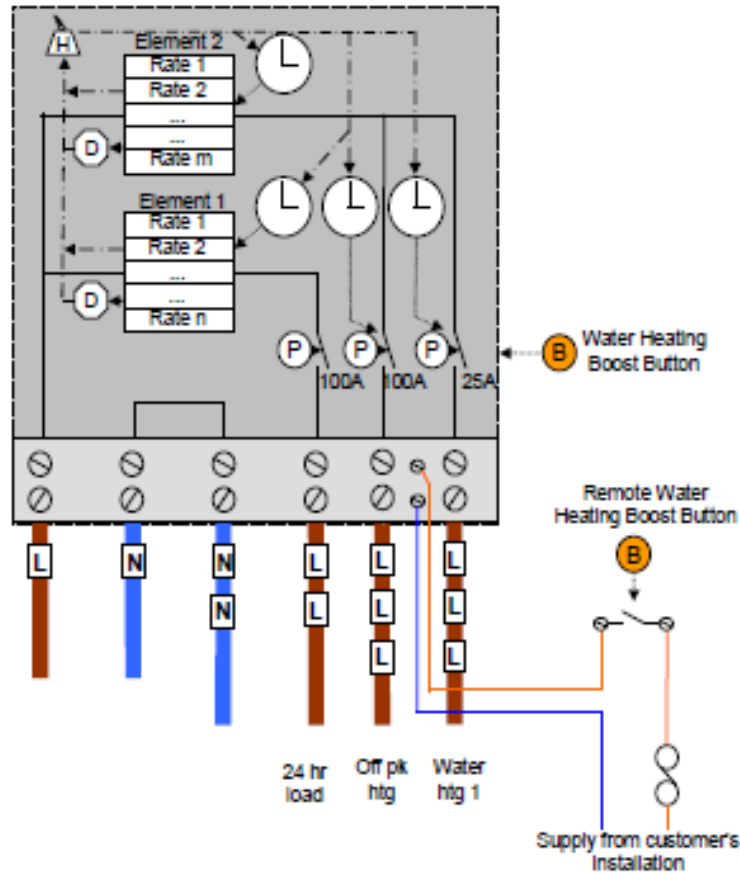

Notes:

- 1 The second 100A contact is typically programmed to control the off peak load coincident with the night rate register.
- 2 The 25A contact may close for different (reduced) times.
- 3 The meter to have button and/or connection for remote button to boost the water heating, ie manually add 1 or 2 hrs charge. The remote connection to be as existing. This function to be configurable.

Figure 13 – Single Phase 2 wire variant S5a 2 Element Meter with Off Peak and Water Heating (“clean” contact) Load Control Switching

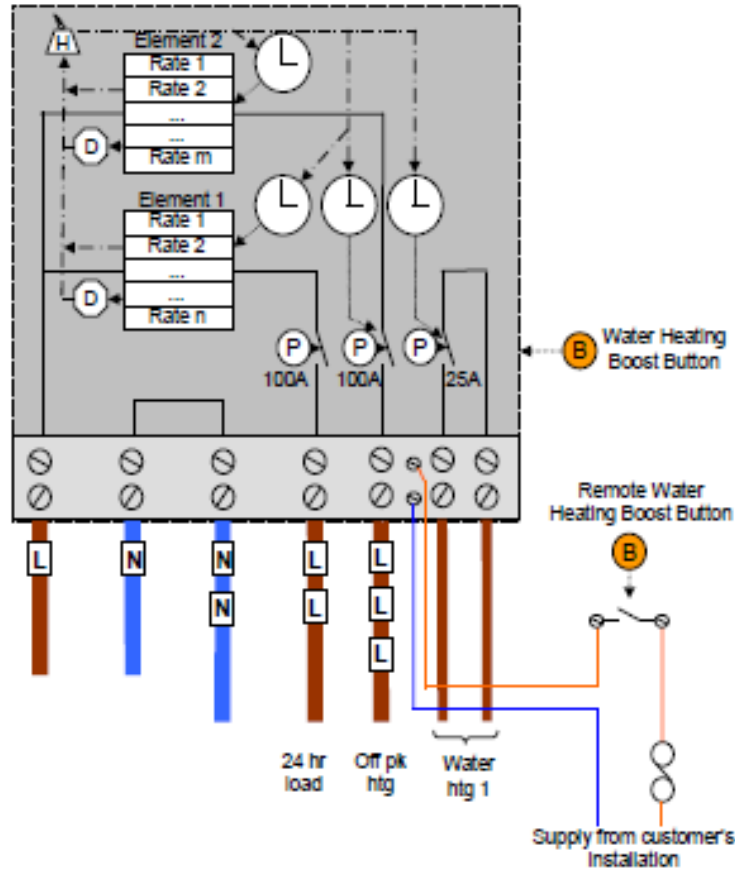

Notes:

- 1 The second 100A contact is typically programmed to control the off peak load coincident with the night rate register.
- 2 The 25A contact may close for different (reduced) times. The 25A contact is typically wired into the customer's final water heating sub-circuit.
- 3 The meter to have button and/or connection for remote button to boost the water heating, ie manually add 1 or 2 hrs charge. The remote connection to be as existing. This function to be configurable.

Figure 14 – Single Phase 2 wire variant S5b 2 Element Meter with Off Peak load and Water Heating Load Control Switching and Separate 2A Relay for Alternative External Contactor Load Control

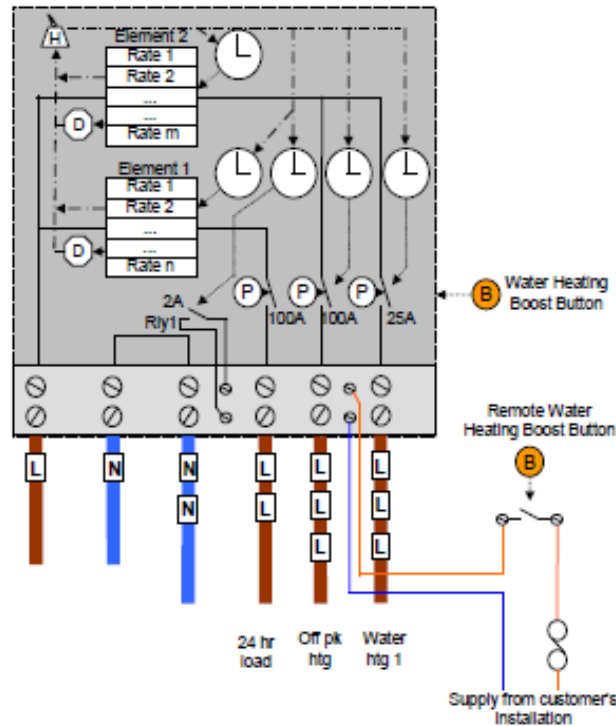

Notes:

- 1 The second 100A contact is typically programmed to control the off peak load coincident with the night rate register.
- 2 The 25A contact may close for different (reduced) times.
- 3 Rly1 is typically programmed to control additional off peak load (eg water heating) via an external contactor. Times may not be the same as the main off peak contact. See variant 1 for typical contactor connections.
- 4 The meter to have button and/or connection for remote button to boost the water heating, ie manually add 1 or 2 hrs charge. The remote connection to be as existing. This function to be configurable.

Figure 15 – Single Phase 2 wire variant S5c 2 Element Meter with Off Peak load and Two Water Heating Load Control Switches

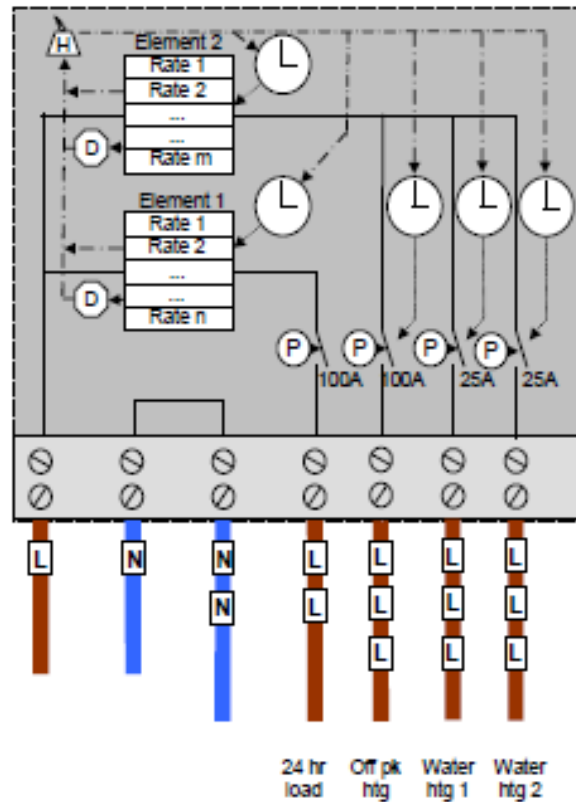

Notes:

- 1 The second 100A contact is typically programmed to control the off peak load coincident with the night rate register.
- 2 The 25A contacts may close for different (reduced) times.
- 3 A typical application uses Water Htg 1 to give full water tank charging (bottom of tank heater), and Water Htg 2, in conjunction with a customer-owned timer-controller, allows the customer to top up the heating (top tank heater) at the relevant rate (price) on element 2 active at the time.

Polyphase meters

Table 3 – Polyphase metering variants

Variant Reference	Description	Integral OP2 100A Contactor	Integral OP7 25A Contactor No 1	Integral OP7 25A Contactor No 2	"Clean" OP7 25A Contactor	Relay 1	Relay 2
P1	Base Meter (includes Integral 100A prepayment/enable/disable 3 ph contact)						
P2 (Figure 16)	Base Meter plus Off Peak Rly 1					✓	
P3 (Figure 17)	Base Meter plus Off Peak Rlys 1 & 2					✓	✓

Polyphase Notes:

- EMV WG has been advised by SMDG to assume that all polyphase whole current meters shall have an integral 100A 3 phase contactor for prepayment and enable/disable functionality. P1 is therefore the baseline polyphase meter.
- Because the meter may be subject to Export (whether measured by it or not) the meter must measure the vector outputs of $e1 + e2 + e3$, where $e1$, $e2$ and $e3$ are the measuring elements in each phase.
 - E.g. if $e1 = \text{Import } 3 \text{ kW}$, $e2 = 0 \text{ kW}$ and $e3 = \text{Export } 1 \text{ kW}$, the meter should record Import 2 kW (and Export 0 kW if measuring export).
 - Conversely, if $e1 = \text{Import } 1 \text{ kW}$, $e2 = 0 \text{ kW}$ and $e3 = \text{Export } 3 \text{ kW}$, the meter should record Import 0 kW (and Export 2 kW if measuring export).
- Export would require its own MPAN for Settlements.
- All variants also record import and export reactive power.
- The terminal layouts for the additional terminals are indicative only.
- The data flows shown are for an explanation of the basic operation of the meter function with regard to rate and Load Switch control only. For instance credit transfer to the prepayment function via the HAN, and pricing and reading information to the IHD have not been shown.
- All variants are assumed to be the same rating (e.g. 100A or as determined by Expanded Statement of Design Requirements group).
- The EMV WG has been advised by PDOG to assume the base polyphase meter will include an integral 3 ph contactor. Variant P0 deleted.
- Internal contact and relay ratings shown are indicative.
- The base meter is assumed to be for 3 ph 4 wire systems. It, and the following polyphase variants, may also be required to be approved and tested for use on the following systems:
 - 2 phases of a 3 ph 4 wire system (i.e. 2 phases 120° apart 230V/400V)

² OP - Off Peak

- 1 phase 3 wire (derived from a single phase HV system, 2 phases 180° apart 230-0-230V, 460V between phases)
- “Summation” 1 phase 2 wire (i.e. 2 phases derived from the same source phase, 230V; 0V between “phases”)
- These different system requirements are not repeated for each hardware variant, but are assumed to be required. The following are therefore titled polyphase rather than 3 phase 4 wire.

Figure 16 – Polyphase Meter Variant P2 100A Internal Contactor and 2A relay for External Contactor Load Control.

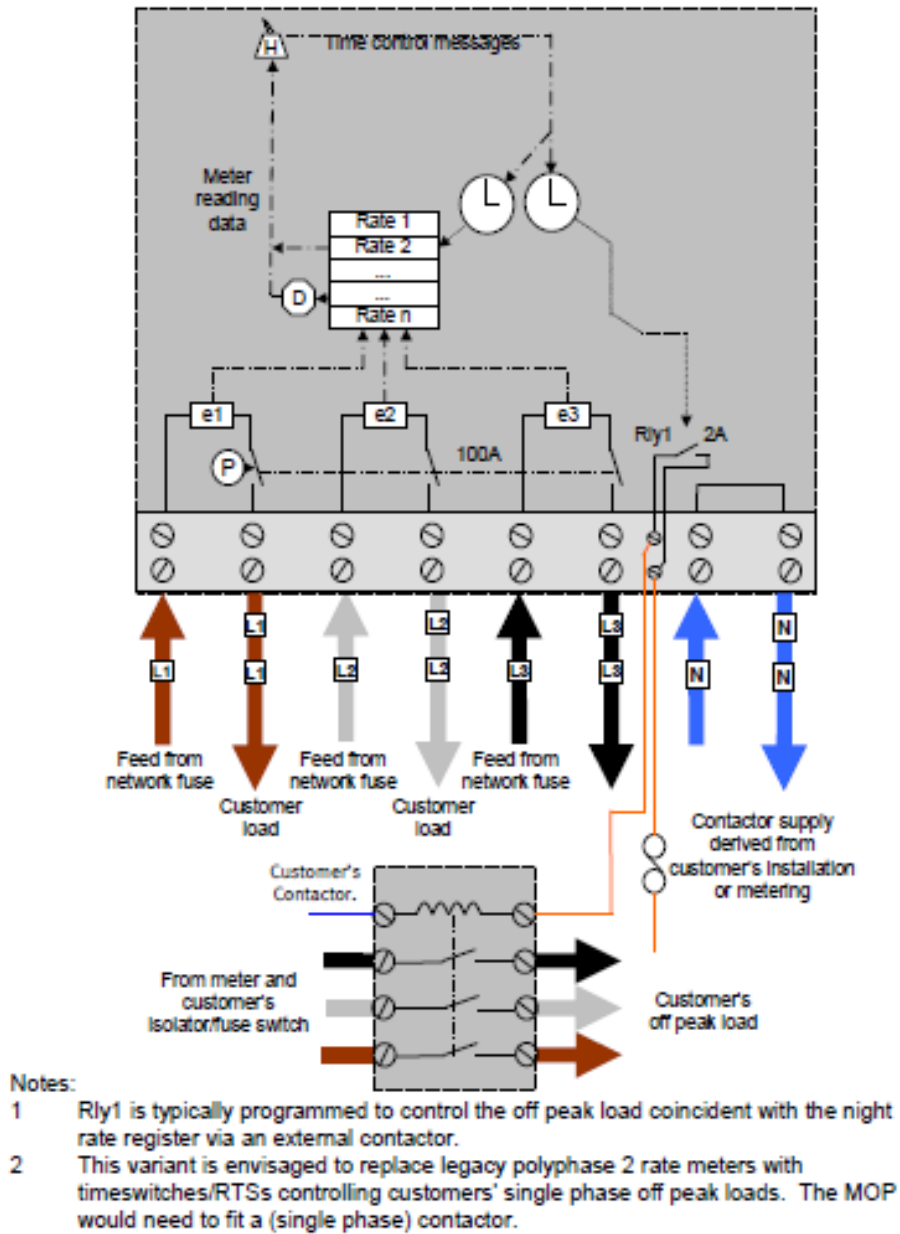
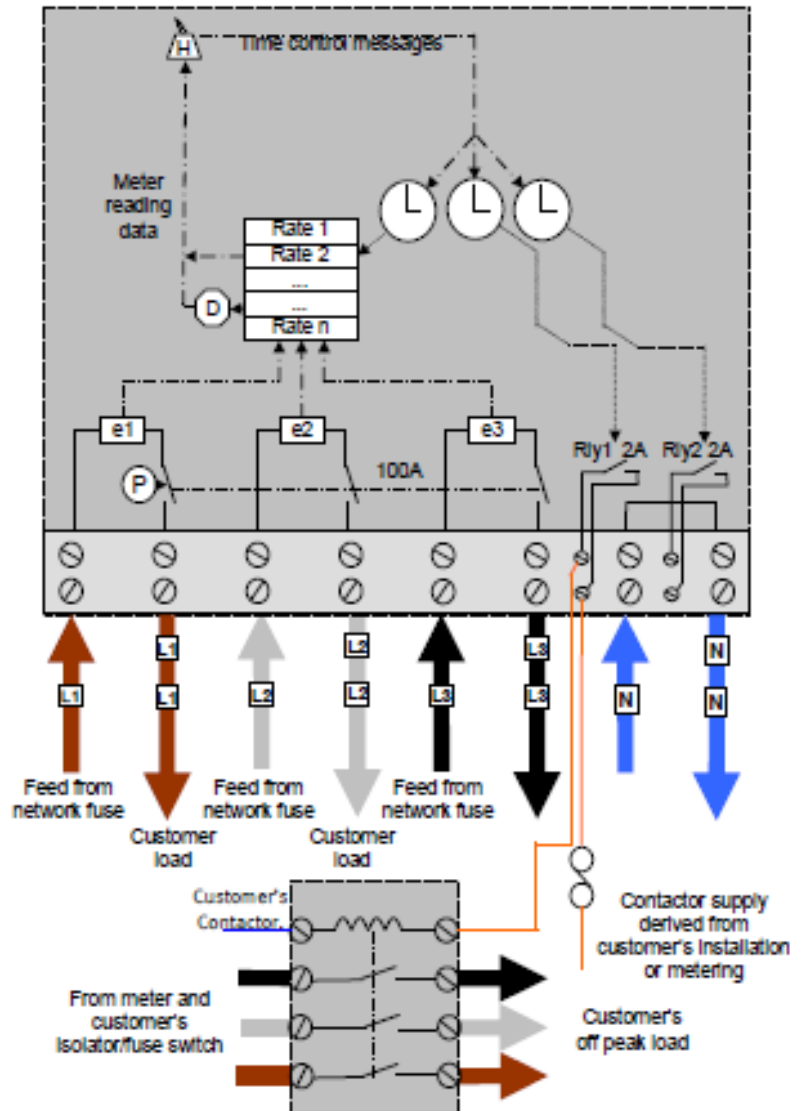

Figure 17 – Polyphase Meter Variant P3 100A Internal Contactor and 2 off 2A relays for External Contactor Load Control.



Notes:

- 1 Rly1 is typically programmed to control the off peak load coincident with the night rate register via an external contactor.
- 2 This variant is envisaged to replace legacy polyphase 2 rate meters with timeswitches/RTSs controlling customers' single phase off peak loads. The MOP would need to fit a (single phase) contactor.
- 3 Rly2 can be used for water heating load control, similar to Rly 1.

Gas meters

1.42. The basic smart gas meter shall conform to industry requirements in terms of basic measuring functionality. Generally these are specified in the requirements of EN 14236, and EN 1359.

1.43. The meter shall calculate and transmit to the Smart Metering HAN the values necessary to provide display values in accordance with the requirements of IH.02.

Meter rating

1.44. For metrological purposes the basic ratings of the domestic meter shall be approved to MID or OFGEM Accuracy Class 1.5 or better.

1.45. The meter rating (Q_{max}) shall be 6.0 m³/h (gas) at a maximum working pressure of 75 mbar.

1.46. The meter shall operate over a minimum temperature range of -10°C to +40 °C within the MPE.

1.47. All meters shall include a pressure test point as specified in BS EN 1359/BS EN 14236.

1.48. The meter shall have a minimum design product life expectation of 20 years.

Design and dimensions

1.49. Meters shall be manufactured using materials compliant with the environmental requirements defined in EN14236.

1.50. Meters shall be suitable for use in meter enclosures as defined in BS EN 6400-1.

1.51. Meters shall be designed and constructed (e.g. type N to BS 6941 or IEC 79-15), such that they are suitable for use in zone 2 classified hazardous areas as defined in BS EN 60079-10.

1.52. Meters shall be designed with a minimum IP 54 Rating as per EN14236 6.2.2.1 to protect against dust and water ingress.

Battery compartment

1.53. The battery shall be integral within the meter but in a compartment, separate from the gasways.

1.54. The battery compartment and battery shall be so designed that the battery is easily changed or replaced without removing the meter from the installation. It shall be possible to change the battery within 2 minutes.

1.55. Battery connections shall be such that connection can only be made with the correct polarity.

1.56. The battery compartment shall be capable of being separately sealed such that there is visual evidence of tamper or other unauthorised interference.

1.57. The battery compartment shall not require the breaking of any metrological authority seal when replacing the battery.

1.58. If required it is suggested that it reads – The battery compartment of each meter shall be sealed either once the battery is fitted at manufacturer or subsequently replaced in the field.

Power Supply

1.59. The meter power supply where used shall conform to the requirements of TC237 section 7 (as at 20011-02-04).

Markings

1.60. The meter shall be indelibly marked as required by the requirements of the approval body but not limited to:

- Approval Body number/marking;
- Manufacturer;
- Serial Number and barcode form;
- Manufacturers type reference;
- Year of manufacture; and
- CE Mark.

1.61. In addition an Emergency contact label shall be supplied.

- The meter shall feature a minimum of two push buttons to provide the means for local Interrogation and prepayment credit entry by the consumer.
- Push buttons shall be clearly distinguishable and shall be tactilely identified.
- Meter displays shall conform to the requirements of DS.07.
- The meter shall conform to the prevailing legal requirements for WEEE.
- The gas meter shall include a Valve in accordance with GS.05.

Architectures

Formats for Interface definitions

1.62. The proposed architecture and architecture variants for the UK Smart Metering System (SMS) are derived from the Smart Metering Coordination Group (SM-CG) model for EU Mandate M/441 compliance – Reference 4. The SM-CG model uses common notation for multiple meter interfaces. Therefore, to provide clarity, the diagrams in this section have GB interface identifiers. These are then mapped to the SM-CG model in the interface table (Table 4 at the end of this section).

1.63. All connections in the SM HAN are illustrated as a star network (also called Hub and spoke) with the data routed via the Communications Hub. This is to simplify the diagrams. However the SM HAN can operate as a peer to peer network, subject to the following authorisation rules:

- Any wired or wireless SM HAN network topology is permissible provided the SM HAN technology used will only allow Authenticated Devices to join and participate on the SM HAN.
- This requirement means that, during installation, a device joining the SM HAN will first have to be authenticated to (or via) the Communications Hub in a 'Master/Slave' relationship.
- Once this process has completed successfully, the device is considered to be trusted and able to communicate with other similarly Authenticated, SM HAN connected, Devices.
- Should the authentication process fail, the SM HAN technology must ensure that the unsuccessful device is not allowed to participate on the SM HAN.
- The relationships between SM HAN connected devices will be configured and managed by the Communications Hub.
- These processes must also apply to other devices such as an enhanced IHD or SM HAN (to non-SM HAN) gateway/bridge.

1.64. The subsequent inter-device (including the Communications Hub) communication mechanism could be either 'peer-to-peer', 'Master/Slave' or 'Hub and spoke' via the Communications Hub.

Primary Architecture (stand alone Communications Hub)

Figure 18 – Primary - Stand Alone Communications Hub

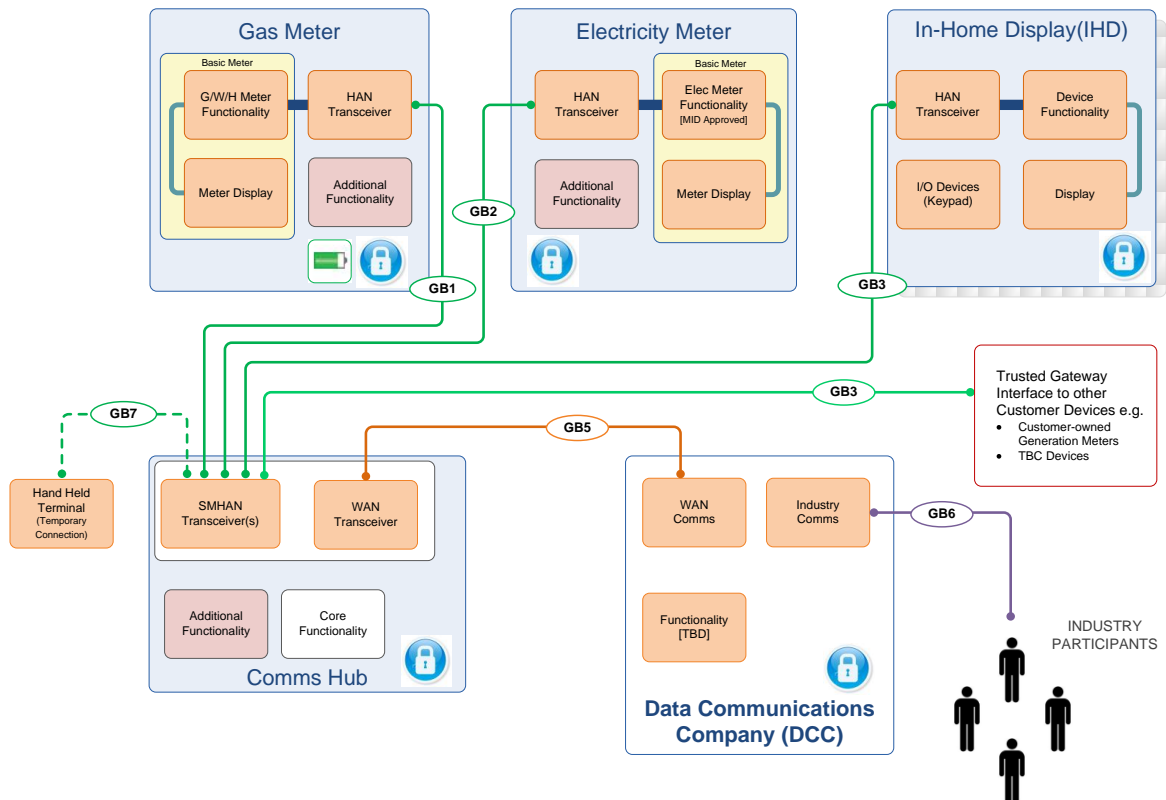

1.65. This schematic (Figure 18) provides a normal operational view of the Smart Metering System devices, interfaces and the distribution of functionality. The following points should be noted:

- The schematic shows a single gas meter, single electricity meter, single Communications Hub but there could be more than 1 IHD.
- The preferred star (Hub-and-spoke) topology does not preclude peer-to-peer connections – see section 1.36
- The interfaces to support Micro-generation, load control and links to a Consumer HAN are set out in Table 4.
- The positions for ‘Additional Functionality’ box in the Electricity meter, Gas meter or Communications Hub are included to reflect the Prospectus requirements beyond core Measuring Instruments Directive 2004/22/EC.

1.66. The Communications Hub will be field-replaceable to facilitate upgrade of the WAN interface.

1.67. The Hand Held Terminal (HHT) provides the commissioning and maintenance interface for the Communications Hub. This does not preclude the HHT connecting via another interface directly with a device, subject to meeting the Security Requirements.

1.68. The mapping of the Prospectus Functional requirements to device level is set out in section 4 of the Architecture Supporting Document.

1.69. All GB identification interfaces are mapped to the M/441 interfaces and defined in Table 4.

Primary Architecture Gas First with a standalone Communications Hub

Figure 19 – Primary Architecture Gas First with a standalone Communications Hub

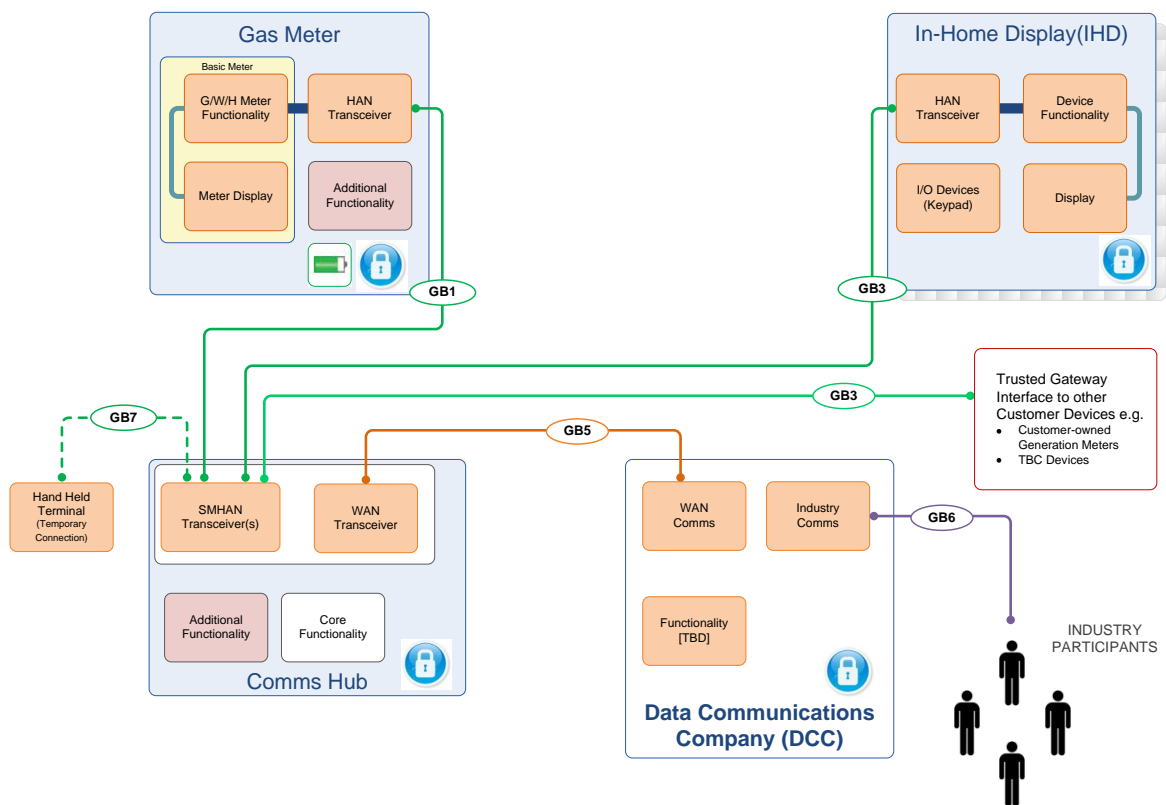

1.70. Figure 19 is identical to Figure 18 but without the electricity meter.

1.71. For installations with this architecture, the Communications Hub is unlikely to be powered from the electricity meter so there needs to be industry agreement on access to a suitable power source to support these installations. Ideally this will be from a secure safe access point on the Distribution Network Operator (DNO) side of the existing “dumb” electricity meter.

Variant 1 – Communications Hub directly attached to Electricity Meter Architecture

Figure 20 – Variant 1 – Communications Hub directly attached to Electricity Meter Architecture

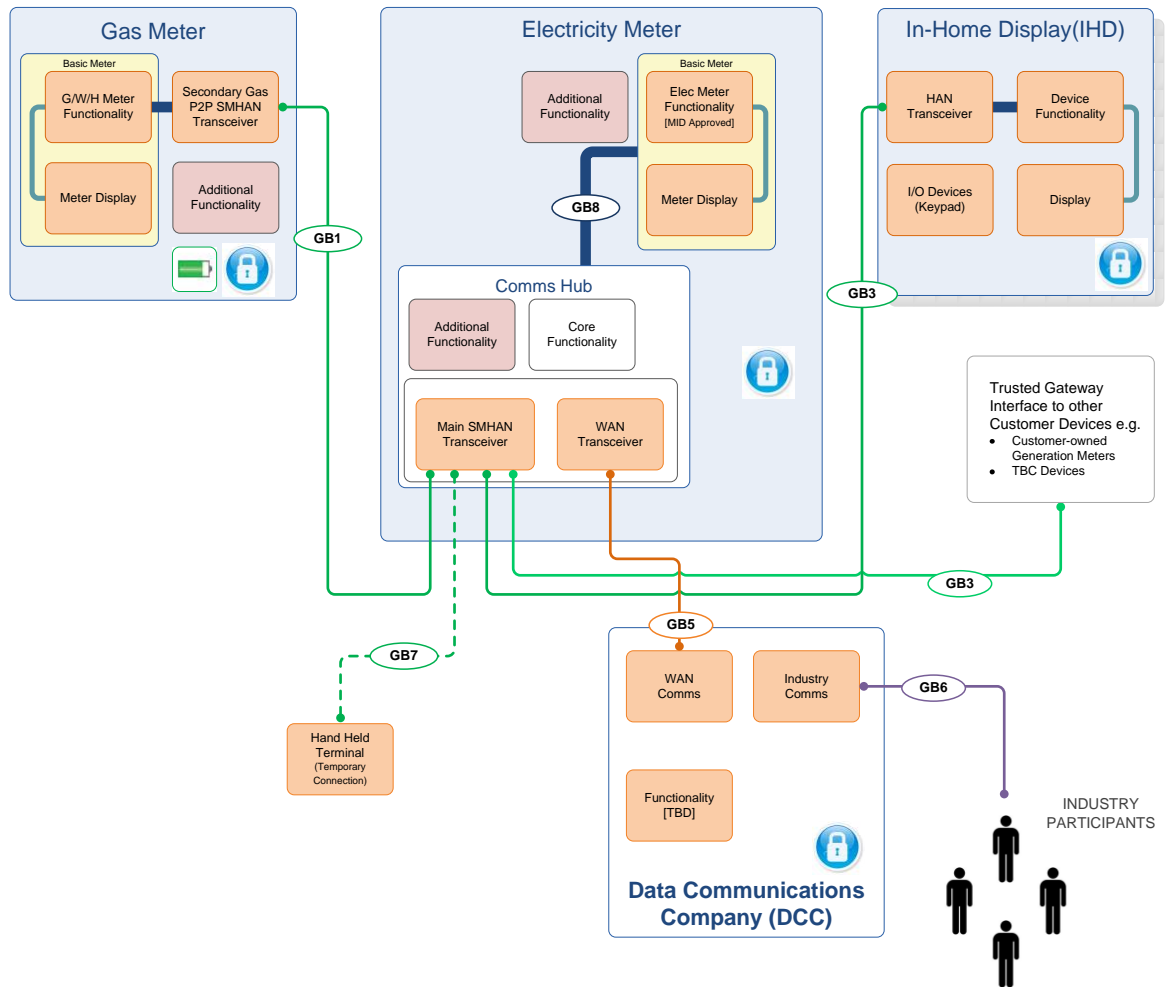

1.72. This variant (Figure 20) extends the form-factor of the electricity meter to enable the Communications Hub to be directly connected as a field exchangeable module. This variant is a solution to overcoming anticipated problems concerning power supply and space at consumers' premises.

1.73. The points noted on the primary architecture, and the interfaces defined, all apply to this variant.

Variant 2 - Potential Architecture variants for Independent Gas installations and Difficult sites

1.74. This section illustrates other architecture variants considered to support both independent Gas installations and sites where smart gas meters are installed first. It includes:

- Gas meter with directly connected battery powered Communications Hub, illustrated as a gas first installation followed by electricity installation.
- Gas meter with directly connected battery powered Communications Hub where the Gas meter is out of range of the SM HAN used for the electricity meter and IHD.
- Gas meter connecting to the Communications Hub via a separate local point to point radio connection. This could be an alternative simpler HAN where the Gas meter is out of range of the preferred SM HAN used for the electricity meter and IHD.

1.75. The relevant working groups have concluded on a range of options for infill technologies to cover problem sites – such as use of a wire within multiple occupant buildings, or a radio with greater range for gas meters. The general view is that real world testing is necessary to assess the suitability of such approaches.

1.76. The focus is on architectures to support metering data used for billing purposes to/from DCC as these should not be dependent on devices powered by the consumer. Communication issues arising from the IHD being out of range are not included.

Independent Gas first with Communications Hub attached to Gas meter

1.77. In this variant, the form-factor of the Gas meter is extended to contain a modular field replaceable Communications Hub.

Figure 21 – Variant 2 – Gas First

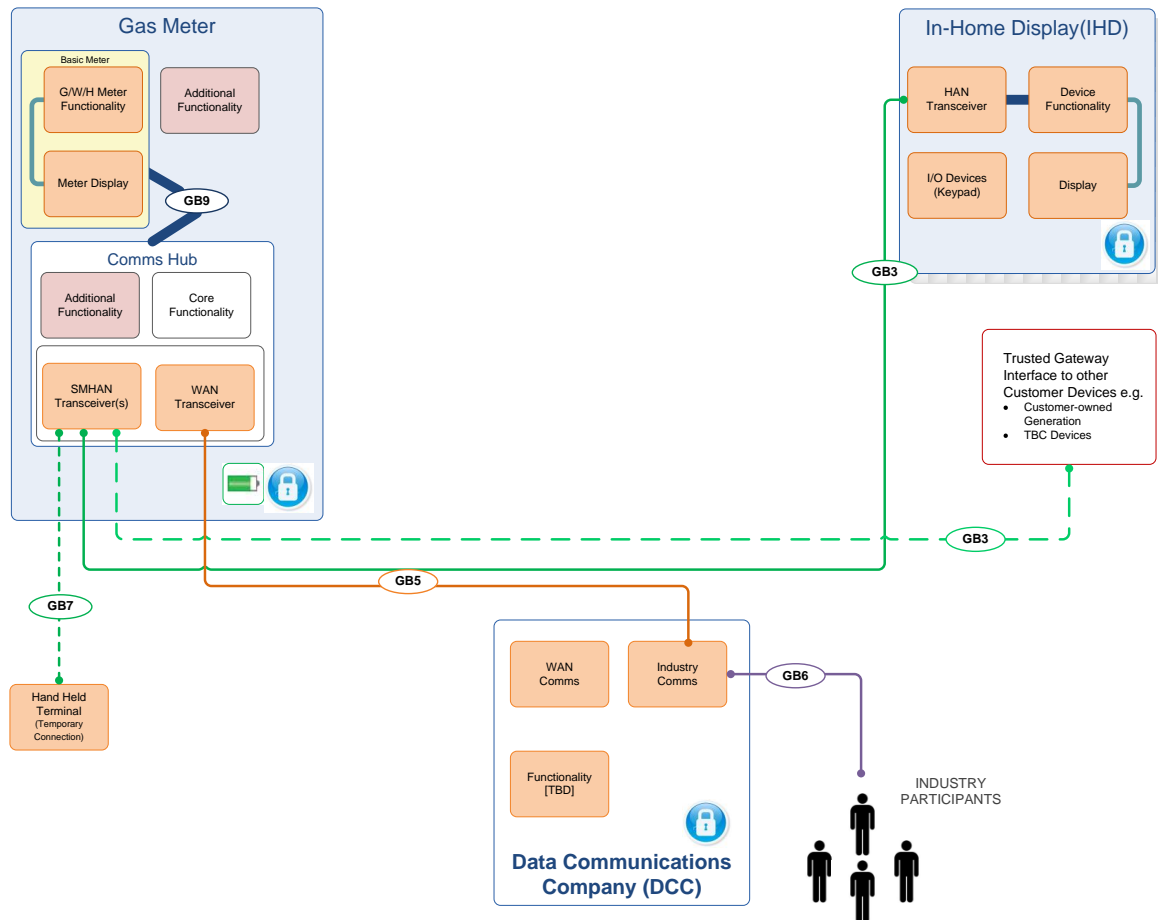

1.78. This illustration (Figure 21) assumes that the Gas meter Communications Hub is in reach of the IHD. It is likely the IHD could have some reduced functionality as it could only access data from the Communications Hub when the Communications Hub is awake. ESoDR requirement HA.11 provides that this will be every 30 minutes by default.

1.79. When the electricity meter is subsequently installed normal operation would be expected to revert to the primary architecture or variant 1. In this case the WAN connection within the gas meter could be disabled.

Figure 22 – Variant 2 – Gas First then electricity meter

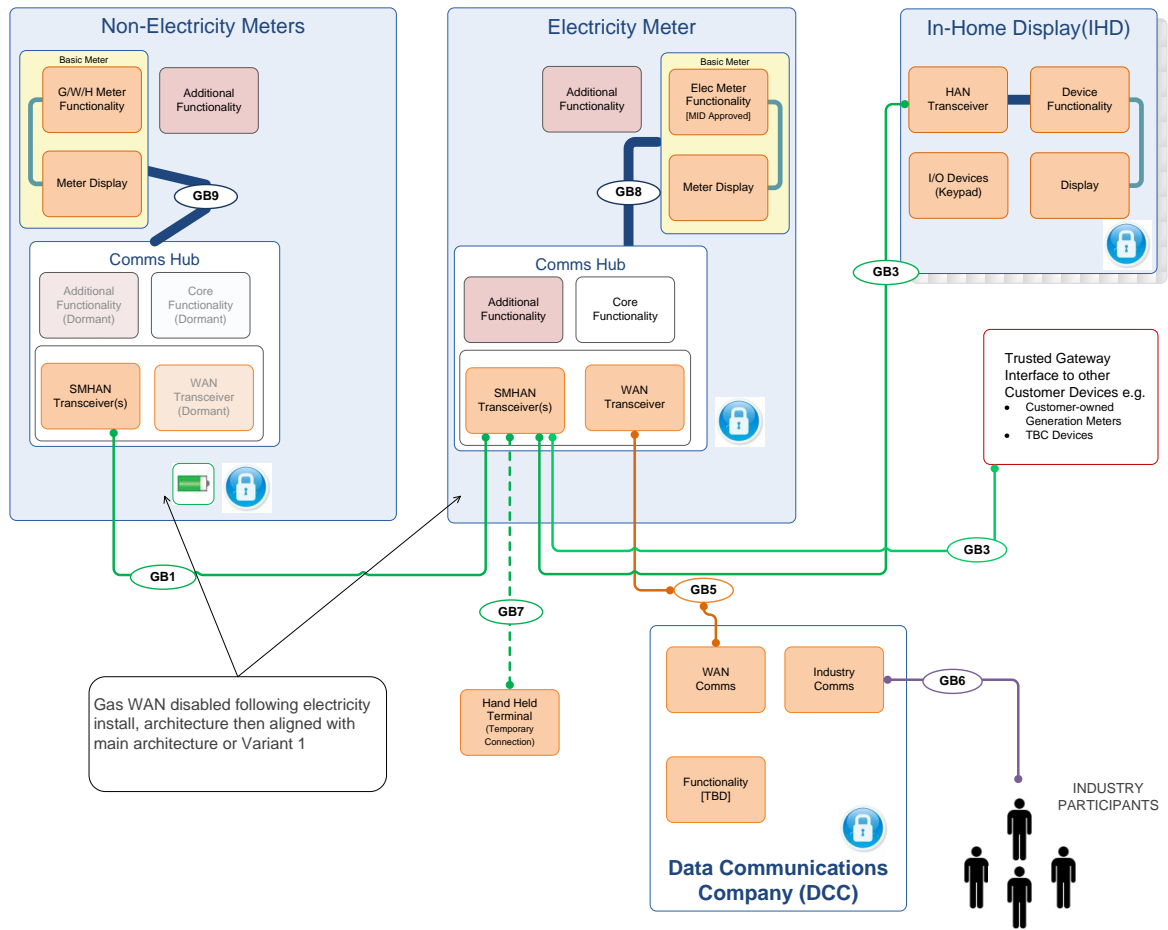

Gas independent WAN for problem sites

1.80. This architecture is one of the two main options for problem sites where the Gas meter is out of range of the main Communications Hub or variant 1 where the Communications Hub is directly connected to the electricity meter (see Figure 22).

Figure 23 – Problem Sites via WAN

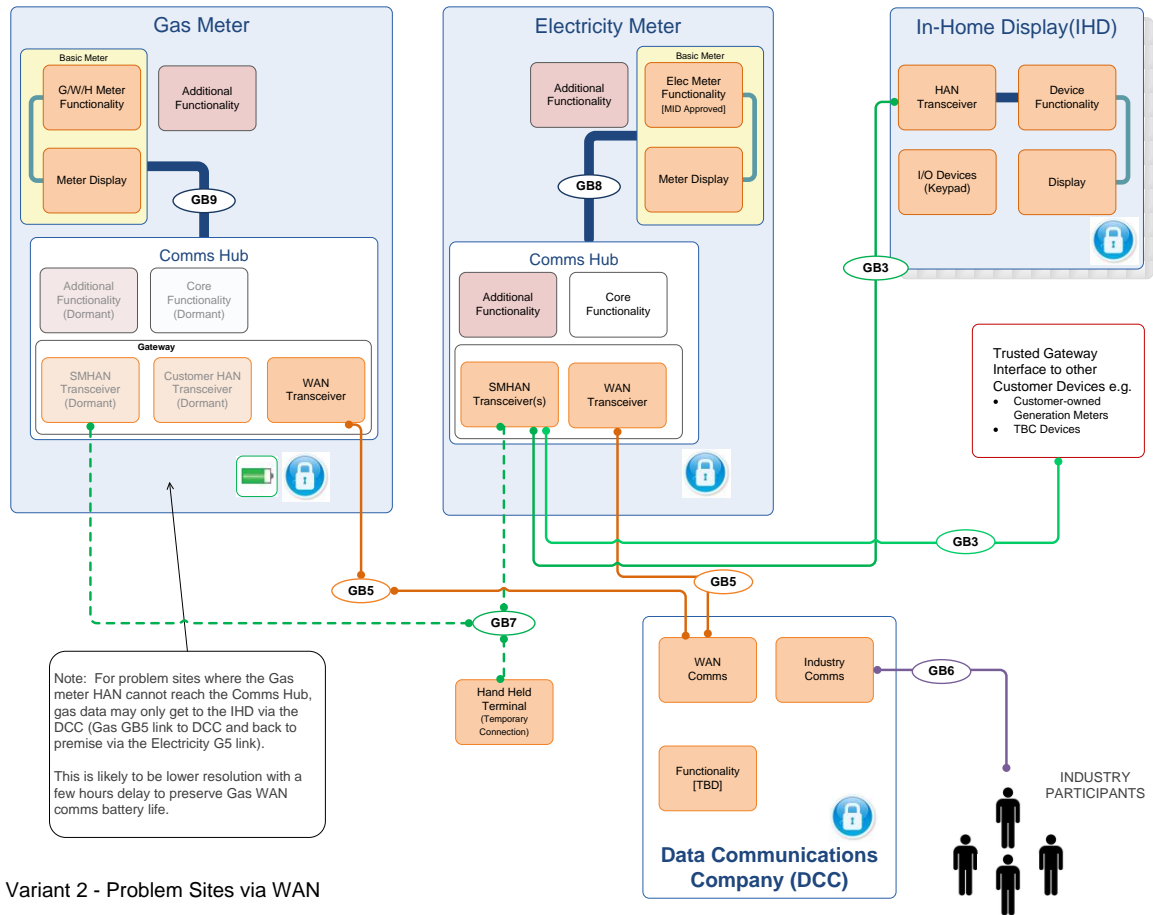

1.81. It is likely that if the gas meter HAN transceiver cannot reach the Communications Hub it may also not reach the IHD (as shown in Figure 23). Therefore, the route for Gas meter data to the IHD will need to be via the Gas WAN connection then routed by either the DCC or the Energy Supplier to the main Communications Hub connected to the Electricity meter, the main Communications Hub will still hold a gas mirror for the IHD. This non-standard routing of data would still need to comply with all security, service and functional requirements. Indeed, whether or not such a solution would be practical remains subject to a detailed security assessment.

1.82. This raises the following issues for this architecture to be deployed:

- Frequency of updates and delays in updating the IHD – the WAN technology and update frequency will impact the battery life of the gas meter.
- Customer permissions required to agree the granularity of data to be provided out of home to the DCC / Energy Supplier to enable it to be sent back for display on the IHD.
- The architecture and routing of data needs to be supported by the DCC business processes, data models and the WAN and SM HAN application layers.

Gas point to point 2nd HAN for problem sites

1.83. Where the preferred SM HAN will not extend between the gas meter and the Communications Hub an alternative approach is to allow an additional point to point wireless radio connection for the connection (as shown in Figure 24 below). This would require the special longer range SM HAN transceiver in the Gas meter and both the preferred SM HAN transceiver and the longer range SM HAN transceiver in the Communications Hub.

Figure 24 – Variant 2 (Special)- Gas Point-to-point

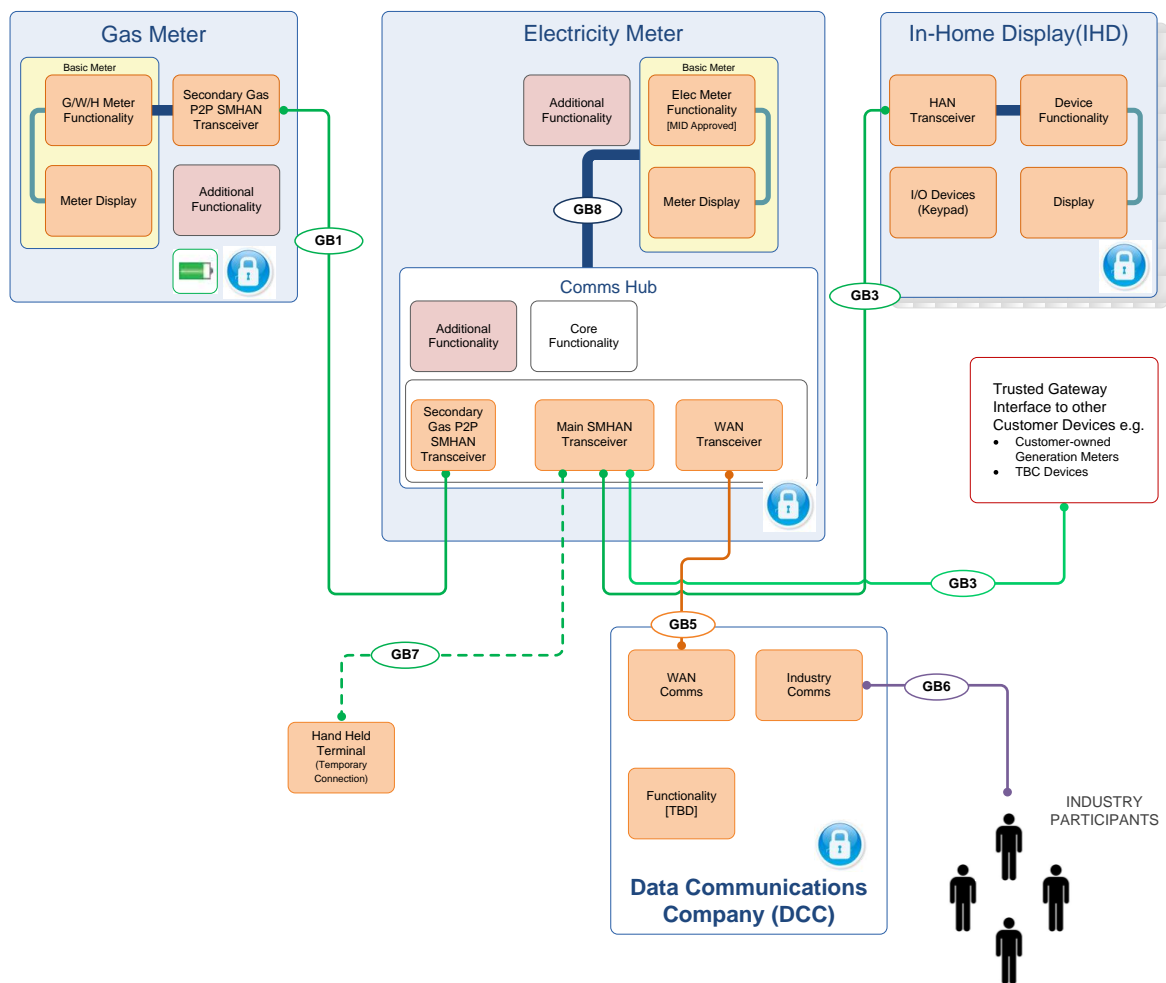

Interfacing with other devices, micro-generation, load control and Consumer Devices

Support for Micro-generation

Figure 25 – Support for Micro-Generation

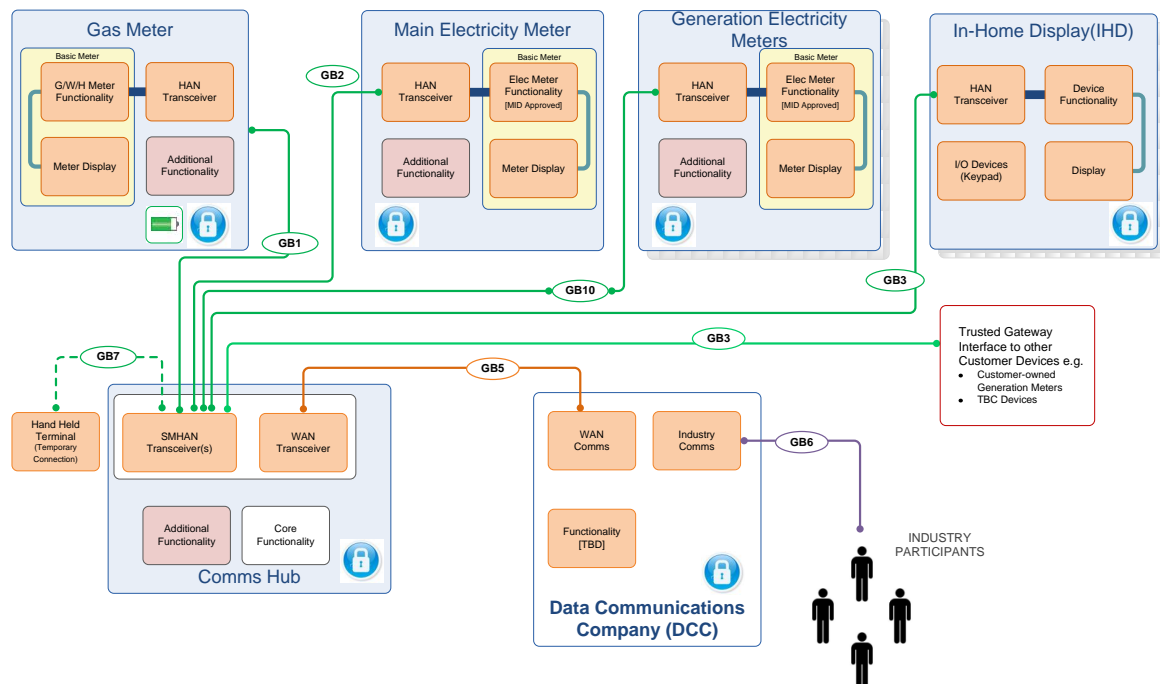

1.84. There are two scenarios for how Micro-generation can be supported within the architectures.

- **Scenario 1.** Where the installation is for a meter by a third party with approved access to the DCC, the generation meter may connect directly to the SM HAN as a trusted device in the same way as the main electricity meter. In this case the consumer can gain access to generation meter data on an enhanced IHD via the SM HAN. The meter shall be required to meet the SMS security requirements as part of this approval.
- **Scenario 2.** Where the installation is either for a non-approved meter or by a third party without approved access to the DCC, the generation meter cannot be connected to the SM HAN. The generation meter could connect to a consumer HAN which is outside the scope of the architecture definitions. In this scheme data exchange will be restricted as set out in the Section entitled “Interfaces to Consumer Networks” below.

1.85. Scenario 1 (above) where the Generation meter is approved to join the SM HAN is illustrated in Figure 25. In this case it is shown with the primary architecture of a Stand Alone Communications Hub. The links for the Generation meter to the Communications Hub are the same for the Architecture variant 2.

1.86. The Generation meter is effectively a replication of the main electricity meter. It has been given a unique interface definition as it may have a different interface definition for application

layer in this configuration and it will have a different interface definition with Architecture Variant 1.

Support for Load Control

1.87. To support load control the following methods may be used:

- Via an electricity meter variant with internal load control functions and additional 5th terminal feed from the meter for the load circuit,
- Via a switched output from an electricity meter variant,
- Via a separate load control device which can be installed as an approved device directly to the SM HAN,
- Via a separate load control device which is installed on the consumer HAN and is not a trusted device on the SM HAN. In this scheme data exchange will be restricted as set out in paragraphs 1.79 to 1.81 below.

1.88. The full range of electricity meter variants to support (a), (b), combinations of these and extensions to them are defined in the Electricity Meter variants document which can be found in Supporting Documents.

1.89. The external load control options (c) and (d) are expected to be used for new load control sites as Smart Metering rollout proceeds.

- Option (c) enables two- way communications via the SM HAN, WAN, DCC to/from the Energy Supplier. However for this the load control device must be an approved device, owned and installed by an approved third party.
- Option (d) could be a consumer owned device (e.g. appliance on the Consumer HAN). However this would then have to be configured to react to standard data that can be published via the Consumer gateway.

1.90. These are not mutually exclusive. For example: a site with multiple load control options could include an electricity meter variant with a combination of (a) and (b) and there may also be consumer connected load control devices reacting to price signals.

Interfaces to Consumer networks

1.91. The proposed method to allow consumers to gain access to local data is shown below in Figure 26.

1.92. Consumers will interface with the Smart Metering System through an approved Gateway Device. This will provide a secure “bridge” between the Smart Metering HAN (SM HAN) and other communications networks within the consumer’s home (e.g. Consumer’s WiFi), known as the Consumer HAN (C HAN).

Figure 26 – Proposed method for Consumers to have local access to data

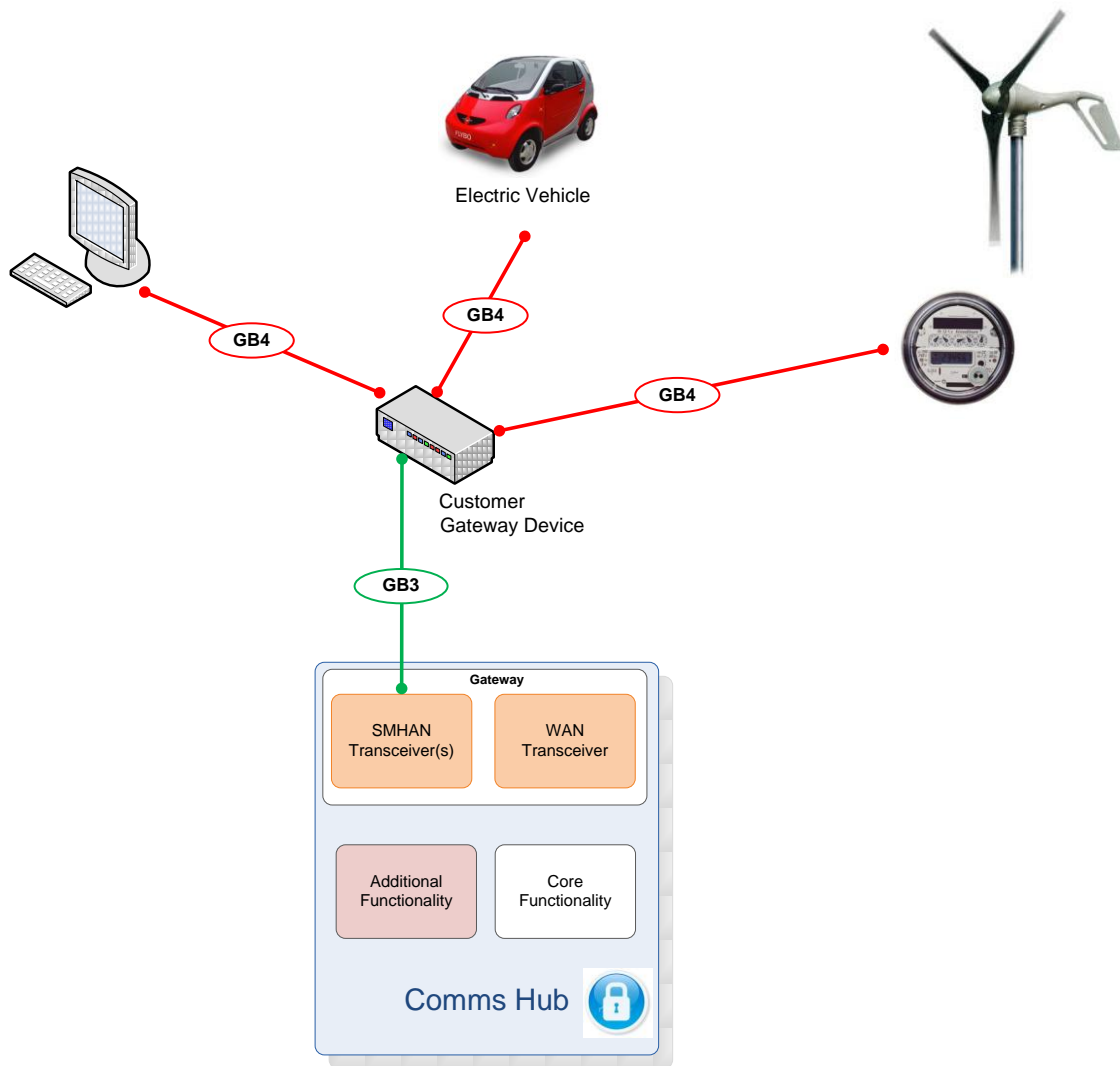

1.93. For this scheme the Gateway device will need to be an approved device. The option would have to mitigate the potential risk of security attacks, on the Gateway device, and attacks on SM HAN.

1.94. The Gateway device will have access to consumer related data from the SM HAN e.g. data items also used by the IHD on energy usage, pricing, tariffs, historical data 13 month storage etc.

1.95. The Communications Hub could also read a limited defined set of data objects from the Gateway device to support simple Generation meters and load control devices that are sited on the Consumer HAN.

Table 4 – Interface Definitions

GB ID	M/441 Draft TR ID	Purpose	Used Where?			Architectural Layer			EU / Standards Working Groups	UK Working Groups with an interest (* Denotes Lead)
			Preferred	Variant 1	Problem Sites	Proposed Physical	Proposed Networking	Proposed Application		
GB1	M	Link between the Gas meter HAN interface and Communications Hub (SM HAN Transceiver)	✓	✓	✓ Note1	TBA AWAITING HAN SELECTION	TBA AWAITING HAN SELECTION	SMART ENERGY PROFILE 1.x	CEN TC 294 BSI PEL 894	SMDG - HAN Selection SMDG - Difficult Meter Positions SMDG - Interoperability Testing SMDP - Application Data Layer
GB2	M	Link between Electricity meter HAN interface and Communications Hub (SM HAN Transceiver)	✓	X	✓	TBA AWAITING HAN SELECTION	TBA AWAITING HAN SELECTION	DLMS/COSEM SMART ENERGY PROFILE 1.x See Note 2	CENELEC TC 13 BSI PEL 13	SMDG - HAN Selection SMDG - Difficult Meter Positions SMDG - Interoperability Testing SMDP - Application Data Layer

GB ID	M/441 Draft TR ID	Purpose	Used Where?			Architectural Layer			EU / Standards Working Groups	UK Working Groups with an interest (* Denotes Lead)
			Preferred	Variant 1	Problem Sites	Proposed Physical	Proposed Networking	Proposed Application		
GB3	H2 & M	<p>Link between the IHD and the Communications Hub.</p> <p>Also includes the link between IHD and any peer to peer devices on the HAN e.g. Electricity meter.</p> <p>Also includes the link between the Communications Hub and a gateway to consumer devices – which is dependent on the outcome of options assessment on consumer HAN interface</p>	✓	✓	✓	TBA AWAITING HAN SELECTION	TBA AWAITING HAN SELECTION	SMART ENERGY PROFILE 1.x	<p>CENELEC TC 205</p> <p>BSI IST6/12</p>	<p>SMDG - HAN Selection</p> <p>SMDG - Difficult Meter Positions</p> <p>SMDG - IHD</p> <p>SMDG - Interoperability Testing</p> <p>SMDG - Micro-generation</p> <p>SMDP - Application Data Layer</p>

GB ID	M/441 Draft TR ID	Purpose	Used Where?			Architectural Layer			EU / Standards Working Groups	UK Working Groups with an interest (* Denotes Lead)
			Preferred	Variant 1	Problem Sites	Proposed Physical	Proposed Networking	Proposed Application		
GB4	H2	Dependent on outcome of options assessment on consumer HAN interface Link between Communications Hub (Customer HAN Transceiver) and 'Un-Trusted' Energy Services & Home Automation devices	✓	✓	✓	Out of scope – Note 3	Out of Scope – Note 3	Out of Scope – Note 3	CENELEC TC 205 BSI IST6/12	SMDG - Micro-generation SMDG - Interoperability Testing SMDP - Application Data Layer
GB5	G1	Link between Communications Hub WAN Transceiver and DCC	✓	✓	✓	DCCG	DCCG	DLMS/COSEM Or dual Protocol –Note 4	ETSI TC M2M CENELEC TC13	DCDG SMDG - Interoperability Testing
GB6	No Equivalent	Link between DCC and Industry participants	✓	✓	✓	DCCG	DCCG	DCCG		DCDG

GB ID	M/441 Draft TR ID	Purpose	Used Where?			Architectural Layer			EU / Standards Working Groups	UK Working Groups with an interest (* Denotes Lead)
			Preferred	Variant 1	Problem Sites	Proposed Physical	Proposed Networking	Proposed Application		
GB7	M	Link between Hand-Held Terminal and Communications Hub (SM HAN Transceiver)	✓	✓	✓	TBA AWAITING HAN SELECTION	TBA AWAITING HAN SELECTION	SMART ENERGY PROFILE 1.x See Note 2	CEN TC 294 / CENELEC 13	SMDG - Installation & Maintenance SMDG - Interoperability Testing
GB8	M (Var 1) I others	Link between Electric meter functionality and an integral Communications Hub interface	X	✓	X	Internal	Internal	Wireless link same as GB2. Wired link DLMS/COSEM or Out of Scope - Note 5	CEN ELEC TC 13 BSI PEL 13	AMO/BEAMA SMDG - Interoperability Testing SMDP - Application Data Layer
GB9	M (Var 2) I others	Link between Gas meter functionality and an integral Communications Hub interface	X	X	✓ Note 4	Internal	Internal	Out of Scope - Note 6	CEN TC 294 BSI PEL 894	AMO/BEAMA SMDG - Interoperability Testing SMDP - Application Data Layer

GB ID	M/441 Draft TR ID	Purpose	Used Where?			Architectural Layer			EU / Standards Working Groups	UK Working Groups with an interest (* Denotes Lead)
			Preferred	Variant 1	Problem Sites	Proposed Physical	Proposed Networking	Proposed Application		
GB10	M	Link between approved Generation meter SM HAN interface and Communications Hub (SM HAN Transceiver)	✓	X	✓	TBA AWAITING HAN SELECTION	TBA AWAITING HAN SELECTION	TBC DLMS/COSEM or SMART ENERGY PROFILE 1.x Note 7	CEN ELEC TC 13 BSI PEL 13	SMDG - HAN Selection SMDG - Interoperability Testing SMDP - Application Data Layer

- Note 1 –Variant 2/Problem sites covers a number of architectures under consideration primarily for problem sites. GB1 Gas meter to Communications Hub link does not apply to all options under consideration.
- Note 2 – GB2 Interface between Electricity meter and the Communications Hub. The Application Layer group recommend DLMS/COSEM for electricity meter data and Smart Energy Profile 1.x for the SM HAN. Therefore if the HAN Physical and Network layers can support this, the link could be a DLMS/COSEM tunnel for all data transfers Electricity meter to and from the DCC, and Smart Energy Profile 1.x for local data to other HAN devices e.g. IHD. This could also apply to GB7 for HHT communications with the Electricity meter.
- Note 3 – GB4 Interface between the Gateway to consumer HAN devices This is out of scope, the choice of consumer HAN is not limited by the SM HAN devices. Different Consumer HANs can be supported by different Gateway/Bridging Devices.
- Note 4 – GB5 Interface between the Communications Hub and the DCC. This is currently under review between the SMDG Application layer work group and the DCCG. The proposals are DLMS/COSEM and/or Smart Energy Profile 1.x

- Note 5 – GB8 interface between Electricity meter and Communications Hub when the Communications Hub is a directly attached module (Architecture Variant 1), this is initially out of scope. The interface options are described further in the Architectures document, Section 5 “Communications Hub physical connection and field updates” in the Supporting Documents area.
- Note 6 – GB9 This applies to Variant 2 where there is a Communications Hub connected directly to the Gas meter. This is likely to be a specialist product for difficult sites and as such the interface is not defined.
- Note 7 - GB10 interface between the trusted Generation meters and the Communications Hub. This is similar to the GB2 interface and it is possible that the link could be the same as GB2. However, the Generation meters could also be simpler devices and may not all support DLMS/ COSEM.
- Note 8 - All interfaces are subject to further work with STEG to ensure the architectures comply with the end to end security requirements.

Extended Functional Requirements

Installation and Maintenance Requirements

1.96. The installation and maintenance requirements relate to aspects of the Smart Metering equipment such as minimising consumer inconvenience during installation or any subsequent maintenance.

Prospectus Requirement	The Smart Metering System components shall be installable in currently existing meter locations in consumer premises.																
ID	IM.1																
Extended Requirement	<p>IM.1.1 The Smart Metering System components (excluding IHD, CT Metering and U16 Metering) shall be installable in current existing meter locations in consumer premises.</p> <p>IM.1.2 This will be achieved by using Smart Metering System devices manufactured to fit into existing metering installations.</p>																
Extended Narrative	<p><u>Electricity Meters:</u></p> <p>Existing locations will have electromechanical or electronic meters installed. Any new Smart Meter should be approximately equivalent in size to typical pre-payment meters, telemeters and electromechanical meters. A potential issue could be with new premises, where only a modern, small, single phase, single element meter has been installed previously.</p> <p>It is recommended that manufacturers design Smart Metering System components to be as compact as possible. For guidance purposes only, see the following examples of dimensions for existing meters.</p> <p><u>Typical Dimensions:</u></p> <table> <tr> <td>Single Phase Electromechanical meter</td> <td>140 x 130 x 190 (mm)</td> </tr> <tr> <td>Twin Element Telemeter</td> <td>150 x 100 x 210 (mm)</td> </tr> <tr> <td>Single Element Pre-payment meter</td> <td>130 x 60 x 160 (mm)</td> </tr> <tr> <td>Twin Element Pre-payment meter</td> <td>130 x 80 x 160 (mm)</td> </tr> <tr> <td>Three Phase Electromechanical meter</td> <td>210 x 160 x 210 (mm)</td> </tr> <tr> <td>Three Phase Electronic meter</td> <td>170 x 80 x 220 (mm)</td> </tr> </table> <p>Based on Smart Meter technology, currently available typical sizes are:</p> <table> <tr> <td>Single Phase Smart Meter</td> <td>130 x 65 x 175 (mm)</td> </tr> <tr> <td>Three Phase Smart Meter</td> <td>170 x 105 x 245 (mm)</td> </tr> </table> <p>Note: Dimensions are length x width (depth) x height, are external</p>	Single Phase Electromechanical meter	140 x 130 x 190 (mm)	Twin Element Telemeter	150 x 100 x 210 (mm)	Single Element Pre-payment meter	130 x 60 x 160 (mm)	Twin Element Pre-payment meter	130 x 80 x 160 (mm)	Three Phase Electromechanical meter	210 x 160 x 210 (mm)	Three Phase Electronic meter	170 x 80 x 220 (mm)	Single Phase Smart Meter	130 x 65 x 175 (mm)	Three Phase Smart Meter	170 x 105 x 245 (mm)
Single Phase Electromechanical meter	140 x 130 x 190 (mm)																
Twin Element Telemeter	150 x 100 x 210 (mm)																
Single Element Pre-payment meter	130 x 60 x 160 (mm)																
Twin Element Pre-payment meter	130 x 80 x 160 (mm)																
Three Phase Electromechanical meter	210 x 160 x 210 (mm)																
Three Phase Electronic meter	170 x 80 x 220 (mm)																
Single Phase Smart Meter	130 x 65 x 175 (mm)																
Three Phase Smart Meter	170 x 105 x 245 (mm)																

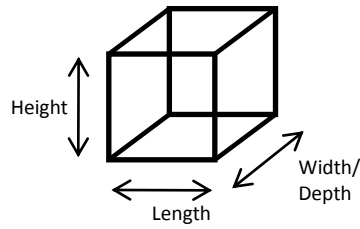

It is anticipated that there will be two architecture options (based on Architecture Support document to the Technical Specification):

- Stand Alone Communications Hub
- Variant Communications Hub Directly linked to the Electricity Meter

For each of these options there are a potential of six scenarios:

- Smart Base Meter (Single Phase, 4 Terminal)
- Smart Variant meter (Single Phase, 5, 6 or 7 Terminal)
- Multiple Smart Meters (Single Phase)
- Smart Base Meter (Three Phase)
- Smart Variant meter (Three Phase)
- Multiple Smart Meters (Three Phase).

Note: Multiple meter arrangements could be required to satisfy existing multi-meter tariff installations.

Note: The only difference between the three-phase Smart Base and Variant meter is an additional 2A relay in the variant. Thus, items 4 and 5 above are likely to have identical footprints.

SMS Footprint (Maximum Envelope)

Scenario 1. – Footprint 150 x 80 x 210 (mm)

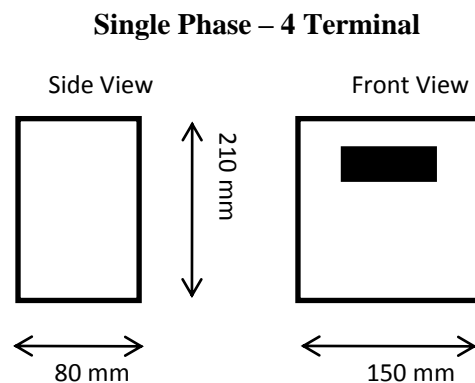

Scenario 2. – Footprint 150 x 100 x 210 (mm)

**Single Phase – 5, 6 or 7 Terminal
(Variant)**

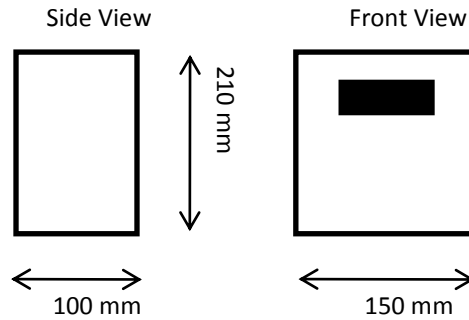

Scenario 3 – Footprint 300 x 100 x 210 (mm) + Minimum separation distance

**Single Phase – Multiple Meters
(Complex Tariff Arrangement)**

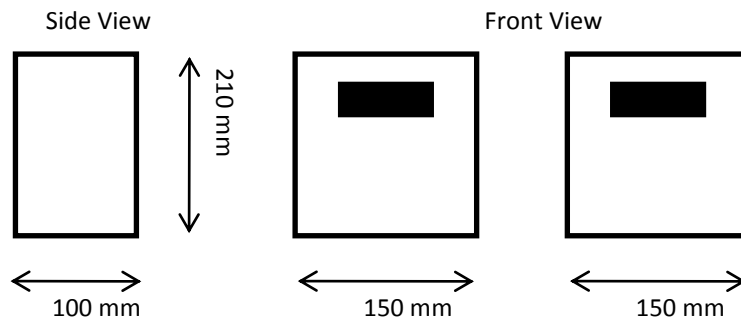

Note: Manufacturers are required to specify the required minimum separation distances between SMS devices.

Scenarios 4. and 5. – Footprint 170 x 110 x 250 (mm)

Three Phase

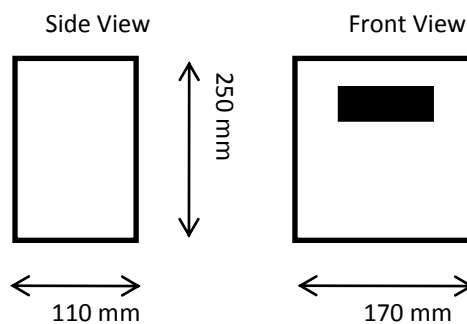

Scenario 6 – Footprint 340 x 110 x 250 (mm) + Minimum separation distance

Three Phase – Multiple Meters

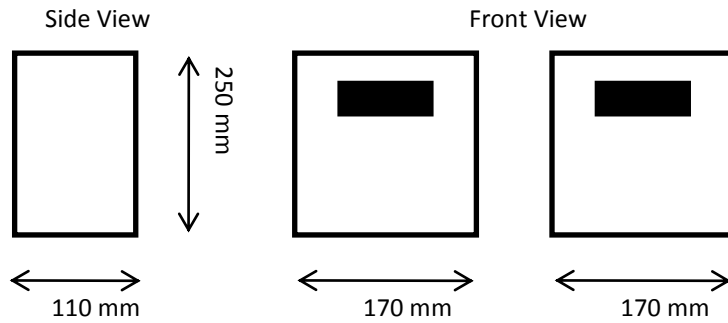

Note: Manufacturers are required to specify the required minimum separation distances between SMS devices.

In the above scenarios, the communications Hub is an integral (modular) part of the electricity Smart Meter. For the scenario of a separate communications Hub, the SMS footprint will increase.

Note: In some circumstances a separate communications Hub may be utilised; this will be a tethered device.

External communication Hub footprint – 100 x 50 x 120 (mm).

Note: This size is an estimate for the average size of existing communication Hubs.

Communications Hub

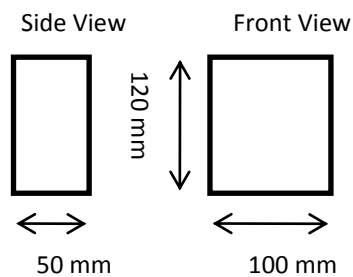

The footprint of Smart Metering System with external communications Hub for the six scenarios previously outlined:

Scenario	Footprint
1	250 x 80 x 210 (mm) + Minimum separation distance
2	250 x 100 x 210 (mm) + Minimum separation distance
3	400 x 100 x 210 (mm) + Minimum separation distance
4 and 5	170 x 110 x 250 (mm) + Minimum separation distance
6	440 x 110 x 250 (mm) + Minimum separation distance

Note: Manufacturers are required to specify the required minimum separation distances between Smart Metering System devices.

Note: As an example, Scenario 1. shown with external communications Hub:

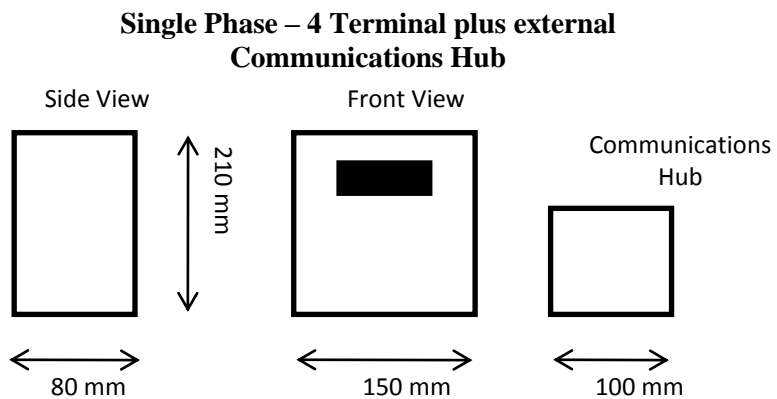

Meter boxes:

In some situations, the meter position is external to the property in a Meter box; any Smart Meter would be required to fit inside. For guidance purposes only, see the following examples of dimensions of existing meter boxes.

Typical Internal Dimensions:

Wall mounted meter box	405 x 150 x 590 (mm)
Slim wall mounted meter box	270 x 150 x 820 (mm)
Free standing meter box	550 x 140 x 760 (mm)

Potential Issues:

	<p>It is possible that in a recently-built installation, only a modern, single phase, single element, electronic meter has been installed. This is significantly smaller in size than any electromechanical equivalent or telemeter.</p> <p>The typical size of a modern, single phase, single element, meter is 124 x 37 x 80 (mm). A Smart Base Meter might not fit if there is not adequate space around the incoming cable head.</p> <p>Typically, three phase meters have no disconnect facility and thus any Smart three phase meter will be deeper than existing electronic meters. This is needed to accommodate contactors to provide a disconnect (pre-payment) function. A Smart three phase meter may not fit if there is not adequate space around the incoming cable head.</p> <p><u>gas meters:</u></p> <p>The Smart gas meter dimensions shall be suitable for fitting into existing meter installations conforming to BS6400-1; 2006 and BS6400-2; 2006.</p> <p>A variant gas Smart Meter shall be made available that shall fit into the smaller envelope currently satisfied by the E6 ultrasonic meter.</p> <p>Note: This excludes U16 metering.</p> <p><u>SM HAN:</u></p> <p>The physical presence of SM HAN hardware shall not add significantly to the overall size of the metering equipment. Most SM HAN hardware is based on integrated circuitry, although some may require additional components or an antenna. The physical size of SM HAN hardware is a consideration for technology suitability.</p>
Justification	To minimize disruption for the majority of sites. There will be exceptions for meters in difficult to reach locations.
Domestic/Non-domestic	D/ND
Use Case(s)	N/A
Normative Reference(s)	BS6400-1; 2006 BS6400-2; 2006 BS7856
Data Item Reference(s)	N/A
Security Requirement(s)	None identified
Component(s) affected	Electricity Meter, gas meter, Communications Hub

Prospectus Requirement	The Smart Metering System shall enable remote firmware upgrades.
ID	IM.2
Extended Requirement	<p>IM.2.1 The Smart Metering System shall enable remote firmware upgrades.</p> <p>IM.2.2 Software should follow the WELMEC Software Guide as appropriate.</p> <p>IM.2.3 All firmware shall be identified by version number, and version control processes shall be used by the manufacturers. The manufacturer shall employ quality control processes. All such processes shall be certified by independent means as meeting the requirements of BS EN ISO 9001, BS EN ISO 9002, BS ISO/ IEC 9003 or equivalent.</p> <p>IM.2.4 Non-metrological software in the metering system shall not affect the operation of the metrology within the meter.</p> <p>IM.2.5 The Smart Metering System shall support both remote and local firmware upgrades. In the event of a failure to upgrade, the firmware shall revert to the previous version, either automatically or by virtue of a remote command. It shall not require a site visit to revert to previous versions of firmware.</p> <p>IM.2.6 All Smart Metering System components that are capable of firmware upgrade shall have the facility to do so remotely and independently of each other, activating a new image either immediately or at a future date. This includes, but is not limited to, WAN communications, SM HAN firmware (as per HA.12), and tariff capabilities.</p> <p>IM.2.7 It shall not be possible to change any part of the firmware relating to the metrological functionality.</p> <p>IM.2.8 With the exception of metrology firmware, it shall be possible to apply an upgrade or completely over-write a component's firmware.</p> <p>IM.2.9 Following a firmware upgrade, the affected component part of the Smart Metering System shall:</p> <ul style="list-style-type: none"> • Automatically restart without a site visit to restart the component • Confirm status to the DCC/Headend at configurable points through the process. Following a firmware upgrade, the affected component part of the Smart Metering System shall indicate it is functioning correctly. <p>IM.2.10 The firmware version should be stored within the device and be made available to the DCC/Head-end on request.</p>
Extended Narrative	This avoids premises visits in the event that the firmware running on the meter needs changing. This does not include changes to metrological firmware.
Justification	High-level list B
Domestic/Non-domestic	D/ND
Use Case(s)	Relevant Use Case UC 06.01 Update Firmware
Normative Reference(s)	Welmec Software Guide 7.2 Siemens Norm sn29500
Data Item Reference(s)	Device Data. In particular items: Firmware Id Firmware Image

	Firmware Install DateTime Firmware Version.
Security Requirement(s)	SP.1, SP.7, SP.11, SP.12, SP.13, SP.14, SP.18.
Component(s) affected	All SMS Components

Prospectus Requirement	The Smart Metering System shall support in situ exchange of WAN communication technology (without removal of meter).
ID	IM.3
Extended Requirement	<p>This currently gives two alternative sets of requirements. A decision will be made by the Programme following consultation and one of the following options will be retained:</p> <p>EITHER:</p> <p>IM.3.1 The Communications Hub shall be replaceable by an authorised person for each architecture variant:</p> <ul style="list-style-type: none"> • The Communications Hub as a standalone unit, powered from either the electricity meter or via an alternative source • The Communications Hub as a module physically attached to the Electricity meter • The Communications Hub as a module physically attached to the Gas meter. <p>IM.3.2 The Communications Hub being exchanged shall support backup of the SM HAN configuration.</p> <p>IM.3.3 The Communications Hub (or Communications Hubs if there is a separate Hub for gas), shall be exchangeable by authorised personnel without disconnecting the meter(s) from the energy supply.</p> <p>IM.3.4 Any wired or power connections shall be secure, thus preventing consumer access.</p> <p>OR:</p> <p>Alternative proposal agnostic of Communications Hub or WAN module</p> <p>IM.3.1 The device that provides WAN connection shall be replaceable, without the interruption of energy supply to the premises.</p> <p>IM.3.2 Exchange of the device shall require the use of specialized tools. This is to ensure that:</p> <ul style="list-style-type: none"> • Only authorised personnel can perform the task • The connections to the device are secure and protected from consumer access. <p>IM.3.3 Where a device offers additional functionality (for example, a Communications Hub including SM HAN coordination) then the device shall support:</p> <ul style="list-style-type: none"> • Backup and restoration of the SM HAN configuration – either locally to the HHT or remotely with the DCC
Extended Narrative	The alternative proposal covers both a Communications Hub and a thinner WAN-only module.

Justification	Cost minimisation on changes to DCC Communications providers
Domestic/Non-domestic	D/ND
Use Case(s)	UC 1.01 Commission WAN device UC 1.02 Establish SM HAN UC 1.03 Commission SM HAN device UC 1.04 Exclude HAN device
Normative Reference(s)	N/A
Data Item Reference(s)	The Communications Hub will be identified as a specific Device type using the following data items: Device ID Device Type Device Type Description Device Activation DateTime Device Activation Status Device Removal Date.
Security Requirement(s)	N/A
Component(s) affected	Communications Hub, meters connecting directly to Communications Hub

Prospectus Requirement	The Smart Metering System shall resume normal operation without technician intervention after a failure in the metering system power supply.
ID	IM.4
Extended Requirement	IM.4.1 The Smart Metering System shall resume normal operation without external intervention after a failure in the power supply to the metering system. IM.4.2 The Smart Metering System will retain settings in the event of a loss of power IM.4.3 On restoration of the power supply following a failure, the meters, IHDs, Communications Hub and other devices shall power up and return to the status it was in prior to the interruption. (e.g. rebind, continue metrological function, continue with correct tariff for time of day and meter contactor/Valve state). IM.4.4 For any auxiliary Load Switches or relays included in the Smart Meter the switch status immediately prior to the power failure shall be retained when power is restored. The switch position required by the current date/time shall be adopted within a maximum of 10 seconds following the restoration of power. For avoidance of doubt, no randomisation of this switching time is required. IM.4.5 For any external SM HAN-operated auxiliary Load Switches (i.e. not including those with a battery-backed real-time clock) the Smart Meter shall send commands confirming the switch position required by the current date/time as soon as possible after SM HAN operation has been restored (e.g. within a maximum of 10 seconds following the restoration of power). For avoidance of doubt, no randomisation of this switching time is required.
Extended Narrative	The system should "reboot" without the need for any physical intervention at the

	<p>meter.</p> <p>Where there is a power failure to the Smart Metering System, such as a failure on the electricity network, it should not be necessary for the consumer to take manual action (or require a metering engineer to attend the site) to ensure that the Smart Metering System is able to function when the power is reinstated. This is because this could potentially leave the consumer without electricity or gas supply to their premise unnecessarily as the power has been reinstated.</p> <p>As part of the ‘last gasp’ process when a Smart Metering System loses power, the system should be able to record its current state at the point of the loss of power (which includes SM HAN device relationships and all configurable parameters within the Smart Metering System) and revert to this state automatically when the power supply is re-instated.</p>
Justification	Impact Assessment
Domestic/Non-domestic	D/ND
Use Case(s)	N/A
Normative Reference(s)	None identified
Data Item Reference(s)	No additional items needed by this Requirement
Security Requirement(s)	N/A
Component(s) affected	Electricity meter, SM HAN-controlled contactors, and communications Hubs

Prospectus Requirement	The Smart Metering System components shall be uniquely identifiable electronically where applicable.
ID	IM.5
Extended Requirement	<p>IM.5.1 Any authorised device connected to the SM HAN shall contain a non-erasable Smart Metering System identifier (serial number) which is unique, and from which it shall be possible to determine:</p> <ul style="list-style-type: none"> • Manufacturer ID • Type of Product identifier (Device ID) • Year of manufacture (Year ID) <p>IM.5.2 The unique identifier described within IM.5.1 shall correspond to the visual serial number displayed on the label as described in requirement IM.6.2.</p> <p>IM.5.3 The SM HAN interface within each Smart Metering System component shall store a unique MAC address (EUI-64 identifier).</p> <p>IM.5.4 All Smart Metering System components shall contain an electronically coded Device Type reference which shall, by cross referencing with a look up table, describe the various attributes of the device.</p>
Extended Narrative	<p>Meters, communications modules, etc. must have a unique electronic identifier for audit trail purposes.</p> <p>This requirement provides for a unique and unambiguous identifier which can be easily interpreted by meter operatives, end users and remote database systems by</p>

	<p>providing key information. The unique identifier when received electronically by any remote system shall leave no room for ambiguity or doubt as to the kind of device, age and manufacturer of the component being referred to. To facilitate this requirement the identifier format of each device type shall be of a uniform design, such that it can be readily recognised and appropriately stored and transmitted by Industry Systems.</p> <p>It should be recognised that MAC addresses associated with SM HAN connected components will be unique but can change during the life of the component. This could happen for example if the communication module associated with a particular SM HAN connected device is ever replaced.</p> <p>It is recognised that legacy database systems associated with existing meter populations will need to continue to support existing gas and electricity meter formats. Recognising the costs associated with changing these systems it has been agreed that the formats associated with smart gas and electricity meters can be of a format that is compatible with that of legacy systems. It is suggested that newer more advanced formats be applied to new types of devices and that in the fullness of time identification formats will evolve, as systems develop, to a unified format.</p>
Justification	High-level list A
Domestic/Non-domestic	D/ND
Use Case(s)	Not Applicable
Normative Reference(s)	EUI-64 Identifier
Data Item Reference(s)	<p>See Device Data.</p> <p>Manufacture ID Year ID (Year of Manufacture)Device ID (Type of Product identifier) Device Type Device Type Description Device Activation DateTime Device Activation Status Device Removal Date</p> <p>See also Network Data</p> <p>Device Address MAC Address</p>
Security Requirement(s)	Not Applicable
Component(s) affected	All Smart Metering System components

Prospectus Requirement	The Smart Metering System components shall be uniquely identifiable physically where applicable.
ID	IM.6

Extended Requirement	<p>IM.6.1 The Smart Metering System components shall be uniquely identifiable by a permanent identifier visible on the component when installed, as per the following requirements.</p> <p>IM.6.2 Any authorised SMS device shall be uniquely identifiable physically (i.e. visually) by an identifier (unique product serial number) which is unique and from which it shall be possible to determine:</p> <ul style="list-style-type: none"> • Manufacturer ID • Type of Product identifier (Device ID) • Year of manufacture (Year ID). <p>IM.6.3 All Smart Metering components shall physically display a coded Device Type reference.</p> <p>IM.6.4 The identifiers described above shall correspond exactly in format to all of the identifiers described in IM.5.</p> <p>IM.6.5 The above requirements shall be achieved by affixing a label or marking plate to each component showing:</p> <ul style="list-style-type: none"> • An indelible, unique product serial number <p>IM.6.6 And also affixing a label or marking plate to the component showing separately:</p> <ul style="list-style-type: none"> • An indelible, unique bar code that includes the product serial number which shall be identical to that held electronically; • An indelible Device Type reference.
Extended Narrative	<p>Meters, communications modules, etc. must have a label / engraving with a unique identifier for audit purposes.</p> <p>This requirement provides for a unique and unambiguous identifier which can be easily interpreted by meter operatives, end users and remote database systems by providing key information. The unique identifier shall leave no room for ambiguity or doubt as to the kind of device, age and manufacturer of the component being referenced. To facilitate this requirement the identifier format of each device type shall be of a uniform design. This will allow it to be readily recognised, appropriately stored and then transmitted by Industry Systems.</p> <p>It should be recognised that MAC addresses associated with SM HAN connected components will be unique but can change during the life of the component. An example of this will be if the communication module associated with a particular SM HAN connected device is ever replaced.</p> <p>It is recognised that legacy database systems associated with existing meter populations will need to continue to support existing gas and electricity meter formats. Recognising the costs associated with changing these systems it has been agreed that the formats associated with smart gas and electricity meters can be of a format that is compatible with that of legacy systems. It is suggested that newer more advanced formats be applied to new types of devices and that in the fullness of time identification formats will evolve, as systems develop, to a unified format.</p> <p>This requirement is separate but complements the Measuring Instruments Regulations:</p> <p>Information to be borne by and to accompany the relevant instrument, Clause 9:</p> <ul style="list-style-type: none"> • Manufacturer's mark or name • Information in respect of its accuracy • Information in respect of the conditions of use

	<ul style="list-style-type: none"> Measuring capacity Measuring range Identity marking Number of the EC-type examination certificate or the EC design examination certificate Information whether or not additional devices providing metrological results comply with the provisions of these Regulations. <p>Markings and inscriptions (Schedule 4):</p> <ul style="list-style-type: none"> CE marking and M marking Notified Body identification number. <p>All marks and inscriptions shall be clear, non-erasable, unambiguous and non-transferable.</p>
Justification	High-level list A
Domestic/Non-domestic	D/ND
Use Case(s)	Not Applicable
Normative Reference(s)	MID
Data Item Reference(s)	Data Items: Manufacturer ID Year ID (Year of manufacture) Device ID (Type of Product identifier) Device Type Device Type Description
Security Requirement(s)	SMM.6, SP.34
Component(s) affected	All Smart Metering Components

Prospectus Requirement	The Smart Metering System components' batteries shall only be exchangeable by authorised personnel.
ID	IM.7
Extended Requirement	IM.7.1 The Smart Metering System components' batteries shall be exchangeable only by authorised personnel. IM.7.2 Gas meter batteries should be field replaceable by Authorised Parties without compromising the device functionality or security. They shall not be accessible to the consumer. IM.7.3 Access to a battery compartment shall be recorded both electronically and by mechanical evidence. IM.7.4 Electronic detection of battery compartment access shall be communicated to the DCC/Headend at the time of detection. IM.7.5 Mechanical detection of battery compartment access should be provided by physical evidence (e.g. broken seals).

	<p>IM.7.6 The battery compartment shall not provide access to other parts of the meter (e.g. PCBs, SIM cards, etc.).</p> <p>IM.7.7 Any batteries used in the Smart Metering System shall be used and disposed of in accordance with the EU Batteries Directive.</p> <p>IM.7.8 Any gas meter battery life timers shall only be able to be reset by authorised personnel.</p>
Extended Narrative	The Smart Metering System components must be protected from inappropriate interference by members of the public. This includes protection against battery replacement in components other than an IHD.
Justification	High-level list A
Domestic/Non-domestic	D/ND
Use Case(s)	N/A
Normative Reference(s)	ATEX Directive
Data Item Reference(s)	N/A
Security Requirement(s)	SP.22, SP.24, SP.26 and SP.10
Component(s) affected	Electricity Meter, gas meter, IHD, Communications Hub

Prospectus Requirement	The Smart Metering System components shall support local access and configurability by authorised personnel.
ID	IM.8
Extended Requirement	<p>IM.8.1 The Smart Metering System components shall support local access and configurability by Authorised Personnel.</p> <p>IM.8.2 Local access to configuration, or local loading of a configuration file, shall be limited to Authorised Personnel, or devices such as a Hand Held Terminal (HHT). Configuration shall include the following:</p> <ul style="list-style-type: none"> • Tariff details (not structures) e.g. unit prices • Setting of switching times between rates/registers • Firmware upgrades • Closing and opening of interruption devices • Prepayment data (debt, emergency and friendly credit settings) • Usage and power monitoring thresholds. <p>IM.8.3 Local configuration shall include the addition of an Approved SM HAN device.</p> <p>IM.8.4 Smart Metering Systems shall allow Authorised Personnel with a HHT to access Smart Metering System data locally.</p> <p>IM.8.5 All configuration changes shall be logged within the Smart Metering System.</p>
Extended Narrative	Local access and configurability, for example to check/change the settings of the meter, will not affect the metrology function of the meter.
Justification	
Domestic/Non-domestic	D/ND

Use Case(s)	<p>Theoretically this may involve any of the following use cases:</p> <ul style="list-style-type: none"> UC2.01 Manage PAYG - Add Credit Remotely UC2.05 Manage PAYG - Adjust Balances UC2.08 Manage PAYG - Self-disconnect Supply UC2.10 Manage PAYG - Set Parameters UC3.01 Update Account balance UC4.01 Manage Events - set event parameters and rules UC5.01 Manage Parameters and Configuration UC6.01 Update Firmware UC7.01 Provide Message for Display UC8.01 Clear data UC9.01 Read Meter - On Demand UC9.02 Read Meter - Historical Reads UC9.03 Read Meter - Schedule Ad Hoc Readings UC9.04 Read Meter - Schedule and Capture Regular Readings UC9.05 Read Meter - Schedule the Transmission of Stored Data UC10.01 Check Status and Settings of a SMS component UC11.01 Enable Supply UC12.01 Disable Supply UC13.01 Set Payment Mode – Set to PAYG UC13.02 Set Payment Mode – Set to Credit UC14.01 Update Tariff UC15.04 Read Generation Data - Schedule and Capture Regular Readings UC16.01 Manage Load - Configure rules set in SMS UC16.02 Manage Load - Manage load by rules set in SMS UC16.03 Manage Load - Manage load by Instruction UC18.01 Configure Device Relationship UC21.01 Restart Supply UC22.01 Access Consumption History UC23.01 Cancel Scheduled Action UC25.01 Record Change of Tenancy UC26.01 Record Loss of Supply UC27.01 Record Gain of Supply UC28.01 Request Change of Supplier Readings UC29.01 Reconnect supply
Normative Reference(s)	None
Data Item Reference(s)	<p>See Device Type and Logging Data.</p> <p>Hand Held Terminal is included in the valid set of device types and will be connectable to the SM HAN.</p> <p>We would also record any changes made to Smart Metering System Settings on the system log.</p>
Security Requirement(s)	SP.18, SP.19, SP.20, SP.21, SP.24, SP.30, SP.31, SP.32, SP.33, SP.35 and all S.HDD requirements.
Component(s) affected	All

Prospectus Requirement	The Smart Metering System shall allow in situ maintenance for non safety critical maintenance.
------------------------	--

ID	IM.9
Extended Requirement	<p>IM.9.1 The gas meter battery shall be exchangeable in situ by competent persons without interrupting the supply.</p> <p>IM.9.2 Gas meter batteries shall be exchangeable in accordance with the requirements in IM.7.</p> <p>IM.9.3 Exchanging the communications Hub shall be possible without needing an electricity meter exchange.</p> <p>IM.9.4 Communications Hubs that are a modular part of the electricity meter should be exchangeable in situ by competent persons without interrupting the electricity supply.</p> <p>IM.9.5 Communications Hub batteries (if applicable) should be field replaceable by Authorised Parties and not accessible to the consumer.</p>
Extended Narrative	The Smart Metering System shall be designed so that any components contained with the meters, that require maintenance throughout the life of the meter, will be able to be exchanged without the need to exchange the meter as a whole.
Justification	Consumer
Domestic/Non-domestic	D/ND
Use Case(s)	N/A
Normative Reference(s)	N/A
Data Item Reference(s)	<p>See Device Type and Logging Data.</p> <p>Hand Held Terminal is included in the valid set of device types and will be connectable to the SM HAN.</p> <p>We would also record any changes on the system log.</p> <p>There are no extra data implications of manual (as opposed to electronic) actions performed locally (such as changing a battery).</p>
Security Requirement(s)	SP.22, SP.24, SP.26, SP.35, SP.8 and SP.10
Component(s) affected	Electricity Meter, gas meter, Communications Hub, IHD

Prospectus Requirement	The Smart Metering System shall support remote identification (by Authorised Parties) of devices attached to the HAN.
ID	IM.10
Extended Requirement	IM 10.1 The Smart Metering System shall support remote identification (by Authorised Parties) of devices attached to the SM HAN.
Extended Narrative	This shall include all devices directly connected to the SM HAN.
Justification	High-level list B
Domestic/Non-domestic	D/ND
Use Case(s)	UC.10.01 Check status and settings of Smart Metering System components
Normative Reference(s)	N/A

Data Item Reference(s)	<p>See Device Data, in particular:</p> <p>Device ID Device Type Device Type Description Device Activation Date Time Device Activation Status Device Removal Date Manufacturer's Make & Type Manufacturer's Model Code</p> <p>See also Network Data:</p> <p>Device Address MAC Address</p>
Security Requirement(s)	N/A
Component(s) affected	Electricity Meter, gas meter, IHD, Communications Hub, Micro-generation meters, and Auxiliary Load Control Switches

Prospectus Requirement	The Smart Metering System shall support a simple installation without the need for manual data entry to the system components.
ID	IM.11
Extended Requirement	<p>The Hand Held Terminal (HHT)</p> <p>IM.11.1 The HHT shall connect as an Authorised Device to the SM HAN.</p> <p>IM.11.2 The HHT shall be capable of communicating with and configuring other Authorised Devices connected to the SM HAN (e.g. to apply tariffs, to associate the MPAN / MPRN to the Smart Meter).</p> <p>IM.11.3 The HHT shall be capable of communicating with and configuring individual electricity and gas Smart Meters not connected to the SM HAN or WAN (e.g. to apply Tariffs, to associate MPAN/MPRN to the meter).</p> <p>IM.11.4 The HHT shall support the collection of data from a Smart Metering System as detailed in IM.5 and IM.6.</p> <p>IM.11.5 The HHT shall support the transmission of configuration data to Authorised Parties.</p> <p>IM.11.6 The HHT shall be able to retain and record Smart Metering System configuration and technical data until the data is transferred to an appropriate system. Such data shall be deleted from the HHT after a prescribed period, as required in the relevant DCC processes.</p> <p>IM.11.7 The HHT shall support local commissioning of authorised Smart Metering System devices, for example:</p> <ul style="list-style-type: none"> • Checking of 'on' / 'off' times of Load Control Switches • Validating other data held, but not available through, the meter's display. <p>IM.11.8 The HHT shall support the addition of authorised devices to, or their removal from, the SM HAN.</p> <p>IM.11.9 The HHT shall support the diagnostic and fault identification of SM HAN- authorised devices within a Smart Metering System.</p> <p>IM.11.10 The HHT shall be capable of accepting firmware upgrades from Authorised</p>

	<p>Parties to enable firmware upgrades to the HHT.</p> <p>IM.11.11 The HHT shall store, support and apply firmware updates to SM HAN- authorised devices.</p> <p>IM.11.12 The HHT shall have a unique identifier as per the requirements in IM.5.</p> <p>IM.11.13 The HHT must meet the Security Requirements.</p> <p>IM.11.14 The HHT shall support the limiting of actions and commands, within defined limits, that can be carried out until it has been re-authorized by a third-party.</p> <p>IM.11.15 The HHT shall support an authorisation procedure managed by an Authorised Party. The procedure can be performed either daily or at agreed timescales as per Industry Governance.</p> <p>Commissioning</p> <p>IM.11.16 The Smart Meter shall have the capability to enter a 'diagnostic' or 'test' mode.</p> <p>IM.11.17 In the 'diagnostic' or 'test' mode the HHT shall be capable of presenting the Events log.</p> <p>IM.11.18 During the 'diagnostic' or 'test' mode, the Smart Electricity Meter shall remain on its correct tariff rate for the time of day. In addition, the prepayment calculations, if enabled, shall continue.</p> <p>IM.11.19 The 'diagnostic' or 'test' mode shall support a 'Time Out' feature, forcing the Smart Meter to return to its normal operational mode. It shall not be possible to leave the device permanently in test mode.</p> <p>IM.11.20 In the 'diagnostic' or 'test' mode the Smart Electricity Meter shall have the ability to cycle through each of the fitted contactors and fitted relays, including the main switch.</p> <p>IM.11.21 This ability to cycle through each of any fitted contactors and fitted relays, including the main switch, shall be initiated either:</p> <ul style="list-style-type: none"> • Via a manual interaction through the Smart Electricity Meter, or • By an authorised command from a HHT. <p>IM.11.22 The states (i.e. "On"/ "Off") of contacts and relays within the Smart Electricity Meter shall be displayed during the cycling on the Smart Electricity Meter.</p> <p>IM.11.23 In the case of external contactors and relays, the Smart Electricity Meter shall be capable of displaying a notification that the "On" / "Off" signal command has been transmitted from the Smart Electricity Meter to the SM HAN.</p> <p>IM.11.24 At the end of the cycle:</p> <ul style="list-style-type: none"> • The contactors/relays are to be restored to their required state • The Smart Electricity Meter display is to be restored to its normal operating mode. <p>IM.11.25 The cycle shall be capable of being terminated before the end of the cycle period. The termination can be triggered:</p> <ul style="list-style-type: none"> • By action of the installer via the Smart Electricity Meter, or • By an authorised command from the HHT. <p>IM.11.26 If the Smart Electricity Meter has a boost button, or has connections for an external boost button, it shall switch to "On" during the cycle mode and its status displayed. At the end of the cycle mode, any activated boost shall switch to "Off" and its status displayed.</p> <p>IM.11.27 The cycle sequence must automatically be terminated by the Smart Electricity Meter after the cycle period has been completed.</p>
--	--

Extended Narrative	<p>For avoidance of doubt, these requirements apply to the base meter and any variants.</p> <p>The processes to support the addition of a device to, or removal of a device from, the SM HAN will be dependent on the chosen SM HAN and the processes agreed with the DCC.</p> <p>During normal operation, when the SM HAN is established, the HHT shall connect, on a temporary basis, to the SM HAN to undertake authorised functions.</p> <p>The HHT shall be restricted in usage in terms of:</p> <ul style="list-style-type: none">• The number of actions it can undertake• The time it can remain authorised to undertake communications with authorised devices. <p>This is to address security considerations, and to limit unauthorised usage.</p> <p>If the WAN is not available, the HHT shall be used to collect the data normally accessed via the WAN. The collected data shall be passed to the requesting party via appropriate and secure third-party systems.</p> <p>Each Smart Meter shall have the capability of initiating a 'diagnostic' or 'test' mode sequence. This should operate for a limited period through the use of a 'time out' feature, for example:</p> <ul style="list-style-type: none">• Following 5 minutes of in-activity) or• Through the authorised installer exiting the 'diagnostic' or 'test' mode. <p>The meter may be put into a test or commissioning mode by an authorised installer, for example by going to a certain display step and then holding the display button down for three seconds, which is acknowledged on the display. Unless this action is taken, the meter should remain in "normal" operation mode.</p> <p>If SM HAN-controlled contactors have been "bound" to the meter; these shall also be included in the cycle sequence.</p> <p>Any contactors may be exercised manually or sequenced automatically, such as 30 seconds "On" then 30 seconds "Off" for each contactor or relay in turn, with the relevant contactor/relay number indicated on the display. The installer can then check that the appropriate external circuit(s) and load(s) are switched on and off at each stage. It should be noted that if there are any limitations in the frequency at which the contactors can be manually cycled (e.g. due to the time needed to recharge capacitors used to store energy to operate the contactors), this should be made apparent to the installer.</p> <p>It should be possible for the installer to end the test or commissioning mode before the end of its timed period. This could be done by repeating the action necessary to enter the cycle mode (e.g. if the button is held down for three seconds during the</p>
--------------------	--

	<p>cycle).</p> <p>Typically, the boost button (whether internal or external to the meter) controls water heating by a 25A contactor within the Smart Electricity Meter. In the cycle mode, the installer shall be able to prove that a switch operation controls the relevant circuit / device.</p> <p>For avoidance of doubt, any energy consumed by the customer's appliances during the cycle sequence should be charged at the rate pertinent at the time of the tests. If the meter is set to prepayment mode, any consumption should result in reduction of credit. Both of these requirements are to discourage customers from attempting to enable the 'test' mode in order to obtain reduced price or free energy.</p>
Justification	Consumer (shorter premises visits)
Domestic/Non-domestic	D/ND
Use Case(s)	<p>The functionality described allows any configuration to take place. However the requirement specifically relates to:</p> <p>UC 01.03 Commission Smart Metering System – Commission HAN device</p> <p>UC 01.04 Commission Smart Metering System – Exclude HAN device</p> <p>UC10.01 Check Status and Settings of a SMS component</p>
Normative Reference(s)	None identified
Data Item Reference(s)	To be confirmed
Security Requirement(s)	<p>SP.46</p> <p>SP.47</p>
Component(s) affected	Electricity meter, SM HAN, HHTs, SM HAN Controlled Contactors, Switches and Relays

Prospectus Requirement	The Smart Metering System shall be installed and maintained in a manner that protects public safety.
ID	IM.12
Extended Requirement	<p>IM.12.1 The Smart Metering System shall be installed and maintained in a manner that protects public safety.</p> <p>IM.12.2 This includes conforming to all applicable and relevant safety legislation and standards, including those listed below.</p>
Extended Narrative	All Smart Metering equipment must conform to the relevant standards. These particular standards relate to the safe design, installation and operation of communicating metering equipment, including compliance with the relevant emissions guidelines.
Justification	Public safety and Health and Safety at Work
Domestic/Non-domestic	D/ND
Use Case(s)	N/A

Normative Reference(s)	<p>Inter alia;</p> <p>Electricity, Gas, and Energy Acts (1986 -) Gas Safety (Installation and Use) Regulations Gas Safety (Management) Regulations Meter Asset Managers Code of Practice (Gas) Codes of Practice (CoPs) for Ofgem Approved (Gas) Meter Installers, (OAMIs), COP/1a, COP/1b and COP/1c Health and Safety at Work etc. Act 1974 Electricity at Work Regulations 1989 Electricity Supply, Quality and Continuity Regulations 2002, and any relevant subsequent revisions Electricity Act, Sch 7 BS 7671 – Requirements for Electrical Installations BS 6400 - Specification for Installation, Exchange, Relocation and Removal of gas meters with a maximum capacity not exceeding 6 m³/h. BS 7856 – Code of Practice for design of alternating current, watt-hour meters for active energy (classes 1&2) Meters (Approval of Pattern or Construction and Method of Installation) Regulations 1990 EN 50385 - Product standard to demonstrate the compliances of radio base stations and fixed terminal stations for wireless telecommunication systems with the basic restrictions or the reference levels related to human exposure to radio frequency electromagnetic fields (110 MHz - 40 GHz). "Guidelines for limiting exposure to time-varying electric, magnetic, and electromagnetic fields (up to 300 GHz)" ICNIRP 1998 – as updated. Published by the International Commission on Non-Ionizing Radiation Protection</p>
Data Item Reference(s)	<p>Device data, in particular:</p> <p>Certification Date Certification Expiry Date Maintenance Date</p>
Security Requirement(s)	N/A
Component(s) affected	All SMS Components

Operational Requirements

1.97. The operational functional requirements relate to aspects of the Smart Metering equipment such as timing, power consumption, minimum modes of operation and fault recovery.

Prospectus Requirement	The Smart Metering equipment components shall not rely on systems or services that are owned or operated by third parties, including consumers, where there is no specific provision to ensure the availability of such systems or services.
ID	OP.1
Extended Requirement	OP.1.1 As far as practicable, the Smart Metering equipment components shall not rely on systems or services that are owned or operated by third parties, including consumers. Provision shall be made to ensure the enduring availability of such systems or services.
Extended Narrative	<p>Energy accounting – whether for billing or prepayment – cannot be dependent on any form of consumer interaction such as line rental or payment for energy to power the system components.</p> <p>However, in certain circumstances, SM HAN communications and connectivity might have to rely on additional installed equipment which, in turn, has some reliance on services such as power that are under the control of the consumer. Appropriate measures should be put in place to limit the exposure of the Smart Metering System to risks associated with this reliance.</p> <p>Reference the following documents for approaches and solutions for challenging sites such as multiple-occupancy premises:</p> <ul style="list-style-type: none"> • HA.09 • Architectures Appendix.
Justification	Existing obligation and high-level list A
Domestic/Non-domestic	D/ND
Use Case(s)	None
Normative Reference(s)	None
Data Item Reference(s)	No specific SM HAN Data Modelling implications
Security Requirement(s)	SP.1
Component(s) affected	Electricity Meter, gas meter, Communications Hub

Prospectus Requirement	The Smart Metering System shall use UTC for all timing functions/date & timestamps.
ID	OP.2
Extended	OP.2.1 The Smart Metering System shall use UTC for all timing functions/date and

Requirement	<p>timestamps. The exception is tariffs, which can operate in either UTC or BST/Local Time.</p> <p>OP.2.2 The Smart Metering System shall store the UTC and use this information for all timing functions/date and timestamps stored and communicated by the Smart Metering System. The exception is tariffs, which can operate in either UTC or BST/Local Time.</p> <p>OP.2.3 Where it displays the time the Smart Metering System shall display local time (i.e. on the IHD and the meters).</p> <p>OP.2.4 The date/time information for the Smart Metering System shall be managed from the WAN. The offset between UTC and local time shall be managed from the WAN.</p>
Extended Narrative	This requirement ensures that a common date and time reference is used for all communication to and from the Smart Metering System. This eliminates any ambiguity that might be experienced with reference to local time changes.
Justification	High-level list A
Domestic/Non-domestic	D/ND
Use Case(s)	N/A
Normative Reference(s)	ITU-R TF.460 – Standard Frequency and Time-Signal Emissions
Data Item Reference(s)	<p>See Device Data, in particular:</p> <p>UTC</p> <p>Local Time Difference.</p> <p>Records such as system changes and logging data will be time-stamped according to UTC.</p>
Security Requirement(s)	N/A
Component(s) affected	Electricity Meter, gas meter, Communications Hub, IHD

Prospectus Requirement	The Smart Metering System shall support “last gasp” communications to notify loss of energy supply.
ID	OP.3
Extended Requirement	<p>OP.3.1 The Smart Metering System shall support “last gasp” communications to notify loss of energy supply.</p> <p>OP.3.2 The Smart Metering System shall be capable of detecting an outage event (i.e. when a phase voltage falls below a threshold of 180V for 3 minutes in line with current industry practice).</p> <p>OP.3.3 On detection of an outage event as described in OP.3.1, the Smart Metering System shall log the loss of electricity supply event, and send a time and date stamped alert to the DCC/Headend.</p> <p>OP.3.4 The Smart Metering System shall, once supply has been restored after an outage, send an alert to the DCC/Headend to notify of the following:</p>

	<ul style="list-style-type: none"> • Time and date stamped supply outage event • Time and date stamped supply restoration event. <p>OP.3.5 On restoration of supply after an outage, the Smart Metering System shall meet the requirements in IM.4.</p> <p>OP.3.6 Any batteries or back up power source used to support OP.3 shall be suitable for the life of the Smart Metering System,(e.g. a minimum of fifteen years) assuming one outage event per year, and batteries shall be field replaceable meeting the requirements of IM.7 and IM.9.</p> <p>OP.3.7 An Authorised Party (via DCC/Headend) shall be able to send a command to each Smart Metering System to establish if the electricity meter is on supply and has an effective communications signal.</p> <p>OP.3.8 The last gasp functionality shall be located within the same unit as the WAN transceiver.</p>
Extended Narrative	<p>Last gasp is the ability, in the event of supply interruption greater than a few minutes, for the Smart Metering System to communicate this event before reverting to any back up supply (for example to keep the legal metrology function active).</p> <p>180V – This voltage is a typical value that is considered to be acceptable for detecting a supply outage, but further review may be required.</p> <p>The ability to ‘ping’ a Smart Metering System to confirm that it is on supply and has a WAN signal is included in WA.02 and WA.03.</p>
Justification	High-level list B (remote diagnostics)
Domestic/Non-domestic	D/ND
Use Case(s)	Relevant Use Case: 24.01 Inform of Outage
Normative Reference(s)	IETF RFC 4180
Data Item Reference(s)	<p>We believe a hardware solution to this requirement will be produced.</p> <p>For contents of the "last gasp" message see Logging Data, in particular:</p> <p>Smart Metering System Id Message Message Sent DateTime Message Sent Participant Id Message Sent Role Code Severity</p>
Security Requirement(s)	N/A
Component(s) affected	Communications Hub and electricity meter
Prospectus Requirement	The Smart Metering System components at the consumer premises comprising single phase electricity meter, communications module, and a mandated IHD shall consume no more than 4.6W combined when averaged and under quiescent operating conditions.

ID	OP.4
Extended Requirement	OP.4.1 The Smart Metering System components at the consumer premises, which comprises of the electricity meter (whether single or three-phase), communications module, and a mandated IHD, shall consume no more than 4.6W per phase, combined, when averaged and under quiescent operating conditions.
Extended Narrative	<p>This limits the amount of energy used to operate the system and relates only to mandated equipment. This assumes a current meter baseline of 2W per phase as defined in EN standards for single or three phase meters, plus 2.6W as set out in the Smart Meter impact assessment.</p> <p>Should additional devices be required to fulfil the operating requirements of the minimum specification Smart Metering System, the total burden shall be no more than 4.6W unless technically unachievable.</p> <p>All meters, their variants and Smart Metering System components, shall meet this requirement.</p>
Justification	Impact assessment
Domestic/Non-domestic	D/ND
Use Case(s)	N/A
Normative Reference(s)	Electricity Meter Standards: EN50470-3; EN62055-31
Data Item Reference(s)	None
Security Requirement(s)	None
Component(s) affected	Electricity Meter; IHD; Communications Hub; WAN Module

Prospectus Requirement	The Smart Metering System time shall be accurate to within 0.5s within 24 hours.
ID	OP.5
Extended Requirement	<p>OP.5.1 Any Smart Metering System component clock shall be set at manufacture, and provision shall be made to adjust the real time clock during the commissioning process.</p> <p>OP.5.2 Clock(s) shall be checked during communications periods using the WAN and SM HAN. The DCC/Headend shall reset the clock if it is out of tolerance (e.g. +/- 10 seconds).</p> <p>OP.5.3 A reset of the Smart Metering System clock(s) is an event that shall be stored in the event log of the relevant component.</p> <p>OP.5.4 For battery-powered nodes the 'unsynchronised' time shall be accurate to within +/- 10 seconds over a 24-hour period.</p>
Extended Narrative	The date and time information within the Smart Metering Systems will be remotely set to UTC on initial installation/commissioning of the Smart Metering System.

	<p>Remote communications with the Smart Metering Systems will include a check of the date and time stored within the Smart Metering System to ensure that it is still aligned with the UTC, and that the date and time within the Smart Metering System have not changed by more than 0.5s within a 24-hour period. This will be assessed by comparison of the current date and time within the Smart Metering System to UTC, and referencing the last time that the date and time within the Smart Metering System was reset to UTC.</p> <p>Whilst the instruction to reset the clock will be serviced by the DCC, the responsibility for clock accuracy will remain with the supplier.</p>
Justification	High-level list A
Domestic/Non-domestic	D/ND
Use Case(s)	N/A
Normative Reference(s)	EN 62054-21, WELMEC 11.2 Issue 1
Data Item Reference(s)	<p>Data Items:</p> <p>UTC</p> <p>Last Timecheck MeterTime</p> <p>Last Timecheck UTC DateTime</p> <p>Last UTC Reset DateTime</p>
Security Requirement(s)	N/A
Component(s) affected	Electricity Meter, gas meter, Communications Hub, IHD

Prospectus Requirement	The Smart Metering System shall support a default mode of operation which is the minimum functionality.
ID	OP.6
Extended Requirement	<p>OP.6.1 The default mode of operation shall operate in the event of a fault condition, for example partial implementation of a Change of Supplier or Change of Tariff.</p> <p>OP.6.2 The default mode of operation shall be in credit mode.</p> <p>OP.6.3 In default mode of operation, the electricity meter shall continue to record:</p> <ul style="list-style-type: none"> • Active energy flow on the total cumulative import kWh register as defined in ES.2 • Half-hourly import KW measurement as defined in ES.6. <p>OP.6.4 In default mode of operation, the gas meter shall continue to record:</p> <ul style="list-style-type: none"> • Gas consumption on the total cumulative m³ register as defined in GS.2 • Half-hourly m³ measurement. <p>OP.6.5 If the default mode of operation is activated, the meter shall:</p> <ul style="list-style-type: none"> • Log an event that this has happened • Display the mode/state of operation on the meter display.

Extended Narrative	<p>Default mode would be entered if there were insufficient configuration data to run the meter in normal operation. Once sufficient configuration data is received, the meter will exit default mode.</p> <p>Default mode of operation may also be used where a Network Operator has exchanged the meter in an emergency and cannot provide supplier configuration data.</p>
Justification	High-level list A
Domestic/Non-domestic	D/ND
Use Case(s)	<p>There are no specific Use Cases.</p> <p>But the entry to the default mode may be called in the failure paths of a number of Use Cases.</p>
Normative Reference(s)	None
Data Item Reference(s)	<p>No specific SM HAN Data Modelling implications.</p> <p>Where Suppliers have introduced extra functionality and data items in addition to this model, the requirement would imply reversion to the functionality and data described in this standard industry specification.</p> <p>SP.7</p>
Security Requirement(s)	N/A
Component(s) affected	Electricity Meter, gas meter

Prospectus Requirement	The Smart Metering System shall support firmware upgrades while maintaining normal metrology functionality.
ID	OP.7
Extended Requirement	<p>OP.7.1 The Smart Metering System shall support firmware upgrades while maintaining normal metrology functionality.</p> <p>OP.7.2 Meter accuracy shall remain within the specified limits whilst a firmware upgrade to the Smart Metering System is being carried out.</p> <p>OP.7.3 All registers/indexes used for billing, including prepayment/PAYG balances, shall operate normally whilst a firmware upgrade to the Smart Metering System is being carried out.</p> <p>OP.7.4 Storage of registers / indexes used for billing, including prepayment/PAYG balances, shall not be affected while the firmware upgrade to the Smart Metering System is being carried out.</p> <p>OP.7.5 Time keeping related to metrology shall remain within limits whilst a firmware upgrade to the Smart Metering System is being carried out.</p> <p>OP.7.6 The firmware upgrade process shall meet the requirements set out in IM.2.</p> <p>OP.7.7 The Smart Metering System shall only carry out a firmware upgrade with firmware that has been accredited, validated, tested and issued by the manufacturer.</p> <p>OP.7.8 The firmware provided for upgrade shall not conflict with existing functionality for other third parties who have permission to configure the Smart Meter for their own requirements e.g. import, export, networks.</p>

	<p>OP.7.9 The Smart Metering System shall not process any pending communications when activating a new firmware image.</p> <p>OP.7.10 The Smart Metering System shall support one upgrade at a time.</p> <p>OP.7.11 The firmware upgrade shall be capable of being activated at a future time/date.</p> <p>OP.7.12 The Smart Metering System shall follow all applicable protocols for authentication, validation, rejection and acknowledgement.</p> <p>OP.7.13 Integrity and confidentiality of the meter and it's data shall not be impaired during a firmware upgrade.</p>
Extended Narrative	Metrology software must be unaffected.
Justification	
Domestic/Non-domestic	D/ND
Use Case(s)	UC 6.01 Update firmware
Normative Reference(s)	WELMEC 7.2 - European cooperation in legal metrology software guide
Data Item Reference(s)	<p>Data Items:</p> <p>Firmware Id,</p> <p>Firmware Image,</p> <p>Firmware Install DateTime,</p> <p>Firmware Version</p>
Security Requirement(s)	SP.1, SP.7, SP.11, SP.12, SP.13, SP.14, SP.18.
Component(s) affected	All

Prospectus Requirement	The Smart Metering System shall be designed such that, if the enablement/disablement mechanism has interrupted the consumer's supply, the restoration of this supply cannot occur without reliable local intervention.
ID	OP.8
Extended Requirement	<p>OP.8.1 The Smart Metering System shall provide a consumer or an engineer with a means to locally Arm and subsequently Restore supply.</p> <p>OP 8.2 The Smart Metering System shall provide a consumer or an engineer with a means to upload a UTRN locally, see also PC.10.</p> <p>OP.8.3 The actions required to physically restore supply shall be as simple and as straightforward as possible (the minimal number of button pushes required) but be designed in such a way that they guard against the possibility of supply inadvertently, being restored locally.</p> <p>OP.8.4 The physical actions required to restore supply shall be identical for both gas and electricity meters operating in Prepayment mode.</p> <p>OP.8.5 The consumer shall be provided with clear prompts, via messages on the meter display, to guide them through the physical restoration process.</p> <p>OP.8.6 It shall be possible, where the supply is armed, to restore the supply through</p>

	<p>reliable and robust physical intervention with the meter or enhanced IHD where appropriate.</p> <p>OP.8.7 When the meter is armed as a result of the addition of credit, or emergency credit, this event shall be logged by the meter and the appropriate data items recorded (cause of arming, new Meter Balance, etc.).</p> <p>OP.8.8 On restoration of supply the meter shall log this event and the source of the restoration request (e.g. physical interaction with meter or through an enhanced IHD).</p> <p>OP.8.9 Following a successful restoration of supply the meter and/or enhanced IHD shall provide the consumer with appropriate visual and audible alerts to confirm that the supply has been restored.</p> <p>OP.8.10 All alerts, or changes of status, in relation to the arming or restoration of supply shall be made available to the SM HAN for their potential use/display by other devices.</p> <p>OP.8.11 The process for restoration of supply (and any messages on the meter display) shall not prevent the ability to navigate to other essential data on the meter display (e.g. meter reads).</p> <p>OP.8.12 When the meter is operating in Prepayment mode and supply has been disabled as a result of insufficient credit, the meter shall locally arm the supply when sufficient credit has been added to the Meter Balance to take it above the configurable supply enablement threshold.</p> <p>OP.8.13 When the meter is operating in Prepayment mode and supply has been locally disabled due to insufficient credit, and the Emergency Credit has not been used, it shall be possible to locally arm and subsequently locally restore the supply by means of a button press, i.e. invoking Emergency Credit.</p> <p>OP.8.14 When a meter is operating in Prepayment mode and supply has been disabled a change to credit mode shall arm the meter .</p> <p>OP.8.15 It shall be possible to remotely/locally configure a meter to operate within Prepayment mode with the Load Switch/Valve functionality disabled. In this mode the meter will allow a supply even when operating in debt but continue to record debt, hence allowing for reparation at a later date. This requirement recognises the potential needs of vulnerable customers.</p>
Extended Narrative	<p>This requirement relates principally to local Valve/Load Switch operations within gas and electricity meters requiring consumer interaction. More detailed requirements relating to Valve/Load Switch functionality as appropriate can be found in ES.1 and GS.5 respectively.</p> <p>For safety reasons, in all circumstances a capable person should be at the premises when the gas supply is restored in order to check that all appliances, etc. have been switched off. See also GS.10.</p>
Justification	High-level list F
Domestic/Non-domestic	D/ND
Use Case(s)	<p>Relevant Use Cases are:</p> <p>UC 2.08 Manage PAYG – Self-disconnect supply</p> <p>UC 11 – Enable Supply</p> <p>UC 12 – Disable Supply</p> <p>UC 21 – Restart Supply</p>

	UC 29 – Reconnect Supply
Normative Reference(s)	BS EN 62055-31
Data Item Reference(s)	<p>Device Data.</p> <p>In particular items:</p> <p>Device Id (Gas and Electricity Wired interface being part of the valid set)</p> <p>Valve Status</p> <p>Supply Status</p> <ul style="list-style-type: none"> • Locally Disabled • Locally Enabled • Locally Restore <p>Threshold Type</p> <ul style="list-style-type: none"> • Reconnection threshold • Disconnection threshold
Security Requirement(s)	SP.1, SP.6, SP.7, SP.18, SP.19, SP.20, SP.21, SP.22, SP.23, SP.24.
Component(s) affected	Electricity Meter, gas meter & Mirror, SM HAN

Display and Storage Requirements

1.98. The display and storage functional requirements cover the visual interfaces of the Smart Metering equipment within the consumer premises as well as data storage. It should be noted that the European Measuring Instruments Directive (MID) also sets out specific requirements for the display of consumption data.

Prospectus Requirement	The Smart Metering System shall display any currency information using £ and pence (but be Euro compatible).
ID	DS.1
Extended Requirement	<p>DS.1.1 Any financial value (e.g. Meter Balance, tariff rates etc.) shall be able to be displayed in Pounds or Euros (to two decimal places) on the Smart Meter operating in PAYG/Prepayment mode.</p> <p>DS.1.2 The maximum value of the Meter Balance field shall be 99999.99 regardless of whether the currency in operation is pounds or Euros. When the Meter currency is Pounds the maximum value of the Meter Balance shall be £99999.99.</p> <p>DS.1.3 If after the conversion calculation, any of the new Euro values exceeds the maximum value allowed for those fields the command shall be rejected, the meter will retain its settings and an error message will be returned to the DCC/Headend.</p> <p>DS.1.4 The Smart Meter shall be able to convert Pounds to Euro's and Euro's to Pounds by receiving a conversion Command (including date and time of action) and the appropriate conversion factor to alter financial balances from Pounds to Euros or Euros to Pounds.</p> <p>DS.1.5 On receipt of a future-dated conversion Command the meter shall provide an acknowledgement of the receipt of the Command to the DCC/Headend.</p> <p>DS.1.6 When the Command is processed the meter will log the processing of the conversion Command and, if configured to do so, will return the confirmation message and associated snapshot data to the DCC/Headend.</p> <p>DS.1.7 Data items represented as currency shall also be converted appropriately, for example debt values, standing charges, repayment rates, tariffs, additional charges, etc.</p>
Extended Narrative	
Justification	High-level list A
Domestic/Non-domestic	Clarification to broaden requirement beyond billing information.
Use Case(s)	<p>The details captured as part of this requirement are linked to the following use cases:</p> <p>UC 0.5 Manage parameters and configuration</p>
Normative Reference(s)	N/A
Data Item Reference(s)	<p>Meter Configuration Data and IHD Display Data, in particular:</p> <p>Meter Mode</p> <p>Meter Mode Description</p>

Security Requirement(s)	Smart Metering System shall not provide any means for customer to change the operational mode of the Smart Meter as this is in read-only mode. Apart from above requirement, there are no other security impacts on this requirement.
Component(s) affected	SMS Components only

Prospectus Requirement	The Smart Metering System shall be capable of storing 13 months of half hourly (kWh and cubic metres) consumption data.
ID	DS.2
Extended Requirement	<p>DS.2.1 The Smart Metering System shall be capable of storing information that may be used by the consumer to facilitate access to services which have potential to be valuable to consumers. The information shall be accessible both locally and remotely.</p> <p>DS.2.2 The electricity meter shall be capable of storing 13 months of half-hourly kWh electricity import interval data.</p> <p>DS.2.3 The electricity meter shall be capable of storing three months of half-hourly kWh electricity export interval data.</p> <p>DS.2.4 The gas meter shall be capable of storing three months of half-hourly m³ gas import data, and the gas meter mirror shall be capable of storing 13 months of half hourly m³ gas import data.</p> <p>DS.2.5 The consumption data shall be accessible locally or remotely in the required format as specified in requirement IN.3.</p> <p>DS.2.6 Data from other authorised utility meters (e.g. half-hourly kWh and kvarh interval data from micro-generation meters), where the data or physical requirements do not exceed those of gas and electricity Smart Meters, should be available to consumers and other Authorised Parties on a similar basis using mechanisms specified in IN.3 (Please also see HA.17).</p> <p>DS.2.7 The Smart Metering System shall, where applicable, store the current tariff identifier and tariff matrix for:</p> <ul style="list-style-type: none"> • Electricity import • Electricity export • Gas import . <p>DS.2.8 The electricity meter and gas meter mirror shall hold the date of the last change of tenancy, to ensure the current consumer may only access data relating to their occupation of the property in line with requirements IN.3 and DS.6.</p>
Extended Narrative	<p>The specified data is required to facilitate access to services which have potential to be valuable to consumers. Some of these services are energy related e.g.:</p> <ul style="list-style-type: none"> • Obtaining energy management / efficiency information • Switching between energy suppliers • Check energy bills • Passing personal energy consumption information to third parties • Monitoring the time that a supply is unavailable. <p>In addition there could be other services which the consumer authorises that use energy related information but are not directly energy related such as Health and</p>

	Social applications. Access to consumption related data stored in the Smart Metering System for other purposes would be available to the consumer remotely on request.
Justification	Consumer
Domestic/Non-domestic	D/ND
Use Case(s)	UC04.01 Manage Events - set event parameters and rules (to define supply outage events) UC04.01 Manage Events - respond to event (to log outage events) UC09.02 Read Meter – Historical Reads UC09.04 Read Meter – Schedule and Capture regular readings UC15.04 Read generation data– Schedule and Capture regular readings UC22.01 Access Consumption History
Normative Reference(s)	None
Data Item Reference(s)	Data Items are: Period ID Advance Tariff Indicator Time Band Name Block Element Name Tariff Rate Action DateTime Action Type Action Value Char Customer Start Date Meter Channel ID Meter ID (Serial Number) Period ID Cumulative Consumption in Period Cumulative Consumption Period Start Date Time Cumulative Consumption Period End Date Time
Security Requirement(s)	None
Component(s) affected	Electricity Meter, gas meter, Communications Hub and IHD

Prospectus Requirement	The Smart Metering System shall support display of mode of operation (credit or prepayment).
ID	DS.3

Extended Requirement	<p>DS.3.1 The meter shall have a configurable display that can be used to indicate to the consumer their current operating mode.</p> <p>DS.3.2 The operating mode display can be configured remotely or locally by Authorised Parties.</p> <p>DS.3.3 The operating mode display shall allow for a sequence up to 18 alphanumeric characters. (Where the number of characters exceeds the static display capabilities of the meter, the meter shall automatically scroll the display so that all of the information it contains can be viewed whenever the relevant screen is accessed by the consumer.)</p> <p>DS.3.4 Where no value has been set for the operating mode display, the meter shall display the default value for its current operating mode. These default values shall include:</p> <ul style="list-style-type: none"> • Credit Mode Default Display – “Credit” • Standard Prepayment Mode Display – “Pay As You Go” • Load Limiting Mode Display – “Restricted Supply” <p>DS.3.5 The meter shall be configurable to display the operating mode on its default screen, in conjunction with other information that has been configured to be displayed.</p>
Extended Narrative	
Justification	Consumer
Domestic/Non-domestic	D/ND
Use Case(s)	<p>The details captured as part of this requirement are linked to the following use cases:</p> <p>UC 05.01 Manage parameters and configuration</p> <p>UC 2.04 Manage PAYG – Display PAYG information Parameters</p> <p>UC 13.01 Set Payment Mode – Set to PAYG</p> <p>UC 13.01 Set Payment Mode – Set to Credit</p>
Normative Reference(s)	N/A
Data Item Reference(s)	<p>Meter Configuration Data and IHD Display Data, in particular:</p> <p>Meter Mode</p> <p>Meter Mode Description</p>
Security Requirement(s)	The Smart Metering System shall not provide any means for the customer to change the operational mode of the Smart Meter as it is in read-only mode. Apart from the above requirement, there are no other security impacts for this requirement.
Component(s) affected	SMS Components only

Prospectus Requirement	The Smart Metering System shall display energy supply status (enabled or disabled).
ID	DS.4
Extended Requirement	DS.4.1 The Smart Metering System shall display energy supply status (enabled or disabled).

	<p>DS.4.2 The Smart Meter shall display the status of the interrupt device on the default display of the meter.</p> <p>DS.4.3 When the supply is on and the meter is not in a state of disablement/enablement (see glossary for definitions), a visual indication that the supply is “On” shall be displayed on the default screen, along with any other information that has been deemed appropriate for this screen (e.g. Meter balance).</p> <p>DS.4.4 When the interrupt device has interrupted the supply the meter shall display a visual indication that the supply is off in the default display followed by additional information based on the reason why the supply is off.</p> <p>DS.4.5 This additional information shall be configurable as part of the definition of the meter’s response to the detection of particular events as specified in requirement DI.1.</p> <p>DS.4.6 Where the number of characters in the additional information exceeds the static display capabilities of the meter, the meter shall automatically scroll this information so that it can be viewed by the consumer.</p> <p>DS.4.7 It shall be possible to display this off supply information in conjunction with any other information which is deemed to be essential for the default display (e.g. for meter operating in prepayment mode this could include the Meter Balance).</p> <p>DS.4.8. If necessary, the information relating to the off supply status shall replace any information detailing the operating mode of the meter that appears on the default display. Where this occurs, when the supply status changes to on, the meter will resume the display of its operating mode on the default display.</p> <p>DS.4.9 For a gas Smart Meter that is off supply and is in sleep mode the consumer will only be able to view the status of the supply by pressing a button on the meter’s user interface.</p>
Extended Narrative	
Justification	Consumer
Domestic/Non-domestic	D/ND
Use Case(s)	<p>Relevant use cases are:</p> <p>UC 2.04 Manage PAYG - Display PAYG Information</p> <p>UC 2.08 Manage PAYG - Self-disconnect Supply</p> <p>UC 11.01 Enable Supply</p> <p>UC 12.01 Disable Supply</p> <p>UC 29.01 Reconnect supply</p>
Normative Reference(s)	N/A
Data Item Reference(s)	<p>Device Data. The following items in particular:</p> <p>Device Id (Gas and Electricity Wired interface being part of the valid set)</p> <p>Valve Status</p> <p>Supply Status.</p> <p>Energisation status</p> <p>Gas interruption status</p>

	Data items that may be passed to the meter as part of the process to change/amend operational mode: Current Operational Mode: "Credit" or "PAYG / Prepayment" (as applicable)
Security Requirement(s)	Smart Metering system shall not provide any means for customer to change the energy supply status of the Smart Meter as this is in read-only mode. SP.22
Component(s) affected	SMS Components only

Prospectus Requirement	The Smart Metering System shall display local time unambiguously (where it is displayed).
ID	DS.5
Extended Requirement	DS.5.1 The Smart Metering System shall display Local Time unambiguously. DS.5.2 The Smart Metering System shall support Local Time change messages that specify: Time Change Date and Time Change Time Change Offset. DS.5.3 At the date and time of Clock Change, the meter shall apply the specified Time Change Offset. DS.5.4 The date shall be displayed in UK format, i.e. dd/mm/yyyy and time in hh:mm:ss. DS.5.5 At manufacture, the relevant components of the Smart Metering System shall be populated with clock changes for the next 30 years.
Extended Narrative	To avoid consumer confusion between UTC/GMT and British Summer Time (BST). Does not apply to time stamps.
Justification	Consumer
Domestic/Non-domestic	D/ND
Use Case(s)	UC.05.01 Manage parameters and configuration
Normative Reference(s)	IEC 62056-61, Cosem Blue book, CLOCK Class
Data Item Reference(s)	Device Data (and IHD Data): Time Change DateTime Time Change Offset UTC Local Time Local Time Difference
Security Requirement(s)	Modification of the variables shall be possible only with the appropriate authorisation. SP.18, SP.19, SP.22, SP.24
Component(s)	SMS Components only

affected	
Prospectus Requirement	The Smart Metering System shall support erasure of data stored locally.
ID	DS.6
Extended Requirement	<p>DS.6.1 The Smart Metering System shall allow Authorised Parties to select data to be erased. Data that can be erased includes:</p> <ul style="list-style-type: none"> • Tariff price data (not structure) and switching times • Supplier thresholds • Supplier specific data/fields (e.g. supplier name/branding on IHD/meter display) • Profile data that is not related to regulated duties of the previous supplier that can be classed as personal data (e.g. interval data for consumers who are not half hourly billed) or any other Authorised Party (e.g. DNO) • Prepayment data including debt values • Messages to the consumer • Alarms/Events (as per DI.1.14). <p>DS.6.2 Data that can be erased during change of supplier and change of tenancy shall not include:</p> <ul style="list-style-type: none"> • Firmware • Metrological data as defined in MID • Any information needed for continued normal Smart Metering System operation. <p>DS.6.3 Each attempt to erase/overwrite local data shall be recorded by the Smart Metering System.</p> <p>DS.6.4 The Smart Metering System shall acknowledge the successful completion of erasure of stored data.</p> <p>DS.6.5 The Smart Metering System shall support erasure of data on receiving a remote or local command.</p> <p>DS.6.6 The Smart Metering System shall send a rejection message to the issuer for any command that fails validation.</p>
Extended Narrative	This functionality operates in circumstances such as when a consumer moves house or when a fault has been rectified. This functionality must operate within the constraints of MID requirements.
Justification	Consumer
Domestic/Non-domestic	D/ND
Use Case(s)	UC.08.01 Clear Data
Normative Reference(s)	None
Data Item Reference(s)	<p>The data that can be erased is included in the following categories:</p> <p>Tariff price data (not structure) and switching times – see Meter Configuration Data</p> <p>Supplier thresholds – see Thresholds and Triggers</p> <p>Supplier specific data/fields (e.g. supplier name/branding on IHD/meter display) –</p>

	<p>see IHD Display Data</p> <p>Profile data that is not related to regulated duties of the previous supplier (e.g. interval data for consumers who are not half-hourly billed). – see Meter Reading Data</p> <p>Prepayment data including debt values – see Prepayment data</p> <p>Messages to the consumer – see IHD Display Data; Meter Configuration Data</p> <p>The data items relating to recording that the deletion of data has been performed are identified in the Logging Data category.</p>
Security Requirement(s)	SP.18, SP.19, SP.20
Component(s) affected	SMS Meter

Prospectus Requirement	The Smart Metering System shall support the provision of information in a manner that takes account of the requirements of persons with disabilities.
ID	DS.7
Extended Requirement	<p>DS.7.1 The Smart Metering System shall support the provision of information in a manner that takes account of the requirements of persons with disabilities.</p> <p>DS.7.2 The Supplier shall ensure that the services provided to consumers with disabilities conform to, and comply with the 'Equality Act 2010'.</p> <p>DS.7.3 Where current legislation fails to provide governance or guidance, suppliers should apply guidance derived from Government or Non-Government Organisations identified as 'subject matter experts' within the area of Disability Legislation.</p> <p>DS.7.4 Smart Metering System Meters should reflect current industry and manufacturer 'best practice' guidelines in the area of customer interfaces, such as 'Buttons' and 'Displays' (e.g. displayed data should be in plain language and menus should be easily navigable).</p> <p>DS.7.5 Smart Metering System IHDs should reflect current industry and manufacturer 'best practice' guidelines in the area of customer interfaces, such as 'Buttons' and 'Displays' (e.g. displayed data should be in plain language and menus should be easily navigable).</p> <p>DS.7.6 Requirements DS.7.3 and DS.7.4 should employ principles of 'Inclusivity by Design'.</p>
Extended Narrative	<p>Covers any components of the Smart Metering System. Guidelines will be developed in the absence of suitable standards.</p> <p>In terms of the Smart Metering System Meters, the design shall be derived from industry and manufacturer's best practice to provide suitable solutions for persons with disabilities.</p> <p>In terms of Smart Metering System IHDs, guidance and best practice shall be derived from The Ricability Report commissioned by Consumer Focus.</p> <p>The list of Government (Gov) & Non-Government Organisations (NGO) that may be approached, but not limited to seek guidance from include:</p>

	<ul style="list-style-type: none"> • Office for Disability Issues (Gov) • Equality and Human Rights Commission (Gov) • Employers Forum on Disability (NGO) • Ricability (NGO) • RNIB (NGO) • British Deaf Association (NGO).
Justification	Consumer
Domestic/Non-domestic	D/ND
Use Case(s)	N/A
Normative Reference(s)	Equality Act 2010
Data Item Reference(s)	None identified
Security Requirement(s)	None identified
Component(s) affected	All components of the Smart Metering System

Prospectus Requirement	The Smart Metering System shall support English and Welsh language for any human communication.
ID	DS.8
Extended Requirement	DS.8.1 Consumers in Wales must receive messages and instructions provided by the Smart Metering System Components in either Welsh or English according to their selection.
Extended Narrative	There are components of the Smart Metering System with which the consumer will interact. For installations in Wales, these components will allow the interaction to take place in either the Welsh or English language according to the choice of the consumer.
Justification	Consumer
Domestic/Non-domestic	D/ND
Use Case(s)	<p>Relevant Use Cases are:</p> <p>UC2 – Manage PAYG</p> <p>UC3 – Update the display account balance</p> <p>UC7 – Provide message for display</p> <p>UC19 – Locally access usage information</p>
Normative Reference(s)	The Welsh Language (Wales) Measure 2011
Data Item Reference(s)	IHD Data

	Language
Security Requirement(s)	None required
Component(s) affected	Electricity Meter, gas meter & IHD

Prospectus Requirement	The Smart Metering System shall unambiguously identify all of its registers.
ID	DS.9
Extended Requirement	<p>DS.9.1 The Smart Metering System shall use the same register identifiers for the following:</p> <ul style="list-style-type: none"> • Display of information via the Smart Metering System (i.e. on the meter display or on the IHD) • Storage of information within the Smart Metering System • All communication of data sent from the Smart Metering System (e.g. over the WAN to the DCC/Headend and over the SM HAN). <p>DS.9.2 The Smart Metering System (e.g. via the IHD) shall be able to identify the meter(s) for which it displays, stores and communicates register information.</p>
Extended Narrative	<p>It is important that the Smart Metering System uses a consistent method of identifying registers against which consumption/generation/export is recorded for billing and settlements purposes.</p> <p>The same register IDs should be used for the same registers throughout the Smart Metering System.</p> <p>The same identifier must be displayed on the meter itself (where a display is present), on the IHD or any other device connected to the SM HAN that can be used to display register reading information, and on any communication back to the DCC/Headend (for example register readings to be used for billing).</p> <p>This will allow customers to be able to verify their readings against any billing information they receive from their supplier, and cross reference with their Smart Metering System.</p>
Justification	High-level list A
Domestic/Non-domestic	D/ND
Use Case(s)	UC 19.01 Locally Access Usage Information UC 09 Read Meter
Normative Reference(s)	N/A
Data Item Reference(s)	<p>Meter Configuration Data, in particular:</p> <p>Meter Register Description Meter Register ID Meter Register Type Measurement Quantity Description Measurement Quantity Id</p>

Security Requirement(s)	N/A
Component(s) affected	Electricity Meter, gas meter

Interoperability Requirements

1.99. The interoperability functional requirements set out the minimum levels of technical interoperability of the Smart Metering System. Technical interoperability is the ability for different Smart Metering System components to exchange data and work together independent of manufacturer. This ensures that different suppliers can install in premises without having to change existing equipment at change of supplier, thereby minimising disruption to the consumer.

Prospectus Requirement	The Smart Metering System shall be capable of supporting at least two suppliers (i.e. for gas and electricity) in the same premises as well as switching between any licensed suppliers.
ID	IN.1
Extended Requirement	IN.1.1 The Smart Metering System shall be capable of supporting at least two licensed Suppliers (i.e. for gas and electricity) in the same premises as well as switching between any licensed Suppliers.
Extended Narrative	This requirement relates to technical interoperability and provides support for multiple Suppliers and Change of Supplier processes.
Justification	High-level list A
Domestic/Non-domestic	D/ND
Use Case(s)	The requirement describes access rather than use so no Specific Use Cases referenced.
Normative Reference(s)	BS 7856 IEC 62055-31 IEC 62052-11 IEC 62053-21 IEC 62054-21 EN60947-3.
Data Item Reference(s)	Data Modelling team have identified the following data items: Market Participant ID Market Participant Name Market Participant Role Code MPAN Core MPRN.
Security Requirement(s)	SP.6
Component(s) affected	All SMS components

Prospectus Requirement	The Smart Metering System shall allow for change of supplier remotely without premises visit.
ID	IN.2

Extended Requirement	IN.2.1 The Smart Metering System shall support remote Change of Supplier activity, without the need to visit the premises.
Extended Narrative	A technical interoperability requirement.
Justification	High-level list A
Domestic/Non-domestic	D/ND
Use Case(s)	UC 26.01 Record Loss of Supply UC 27.01 Record Gain of Supply UC 28.01 Request Change of Supplier Readings
Normative Reference(s)	BS 7856 IEC 62055-31 IEC 62052-11 IEC 62053-21 IEC 62054-21 EN60947-3.
Data Item Reference(s)	Data Items: Current Utility Supplier Emergency Contact Telephone Supplier General Enquiry Telephone Number Supplier Start Date
Security Requirement(s)	SP.6
Component(s) affected	All SMS Components

Prospectus Requirement	The Smart Metering System shall support non-proprietary data formats for provision of data to consumers.
ID	IN.3
Extended Requirement	<p>IN.3.1 The Smart Metering System shall support the provision of data locally and remotely, in a single common, non-proprietary format. This data may be used by the consumer to facilitate:</p> <ul style="list-style-type: none"> • Access to energy services • Detailed analysis of consumption patterns. <p>IN.3.2 As a minimum, the data file shall include:</p> <ul style="list-style-type: none"> • Up to 13 months of half-hourly kWh electricity import data and m³ of gas import • Up to three months of half-hourly kWh net electricity export data. This data will be available only where micro-generation is installed • The cumulative and the supplier-configured kWh registers for electricity import, export and generation; and m³ for gas import • The calorific value (CV) and PTZ conversion factor applied to the volumetric gas measurement to calculate the energy consumption

- The current tariff identifier and tariff matrix
 - Times of incoming supply interruption and supply restoration data. This is stored within the Event Log and under the requirements of OP.3.
- IN.3.3 The data shall be made available locally via a consumer interface device through the SM HAN. The consumer interface device shall not form part of the Smart Metering System.
- IN.3.4 To ensure the security of consumer data, the Smart Metering System shall not transfer any consumption-related data to a consumer interface device without local intervention, for example human interaction with the Smart Metering System by means of a button press. Local intervention shall authorise data transfer for a configurable period, after which local access to data will not be possible without further local intervention. Where the meter is in a position that is difficult to access, local intervention may be achieved through the Enduring Interface.
- IN.3.5 For domestic properties, the data shall be made available remotely from an Authorised Party via the DCC. For non-domestic properties, data shall be made available remotely from an Authorised Party via either the DCC or another data and communications service provider.
- IN.3.6 To ensure the security of consumer data, the Smart Metering System shall be capable of displaying a numeric code to allow validation of remote data access requests from an Authorised Party using the DCC.
- IN.3.7 The consumer interface device and the DCC or other data and communications service provider shall, as a minimum, output the data in a Comma-Separated Values file.
- IN.3.8 The output file shall include an individual record for each day's electricity import, electricity export, and gas import consumption, if available. Each daily consumption record shall include the following fields:
- Unique equipment identifier
 - Data source (electricity import, electricity export, or gas import)
 - Consumption date
 - 48 interval advances.
- IN.3.9 The output file shall include a record containing the current register readings for electricity import, electricity export, electricity generation and gas, if available. The registers record shall include the following fields:
- Unique equipment identifier
 - Data source (electricity import, electricity export, electricity generation or gas import)
 - Date of request
 - Cumulative consumption (in kWh or m³)
 - For each Supplier-configured register:
 - Register identifier
 - Register reading.
- IN.3.10 Where the Smart Metering System includes a gas meter, the output file shall include a record for the Calorific Value (CV) and PTZ conversion factors. The gas conversion factor record shall include the following fields:
- Unique equipment identifier (gas meter only)
 - Calorific value
 - PTZ conversion factor.
- IN.3.11 The output file shall include a record containing the current tariff information

	<p>for electricity import, electricity export and gas. The tariff record shall include the following fields:</p> <ul style="list-style-type: none"> • Unique equipment identifier • Data source (electricity import, electricity export or gas import) • Tariff indicator • For each time band and block element combination: <ul style="list-style-type: none"> ○ Time band name ○ Block element name ○ Tariff rate. <p>IN.3.12 The output file shall include a record for each incoming electricity supply outage event greater than a configurable period (currently three minutes). The output file shall, where available, include up to 40 electricity supply outage events. The supply outage record shall include the following fields:</p> <ul style="list-style-type: none"> • Unique equipment identifier (electricity meter only) • Supply outage start (DDMMYYYY HH:MM) • Supply outage end (DDMMYYYY HH:MM). <p>IN.3.13 The output file shall not include data relating to any period before the Change of Tenancy (CoT) date.</p>
Extended Narrative	<p>The data is needed to facilitate access to services that have potential to be valuable to consumers.</p> <p>It is envisaged that consumers might analyse the information themselves using standard software packages such as those available from Microsoft or Apple, or upload the information onto websites where third-parties provide services.</p> <p>Some of these services are energy-related e.g.:</p> <ul style="list-style-type: none"> • Obtaining energy management / efficiency information • Switching between energy suppliers • Checking energy bills • Passing personal energy consumption information to authorised third parties • Monitoring the time at which a supply is unavailable.
Justification	Consumer
Domestic/Non-domestic	D/ND
Use Case(s)	UC09.02 Read Meter – Historical Readings UC22.01 Access Consumption History
Normative Reference(s)	IETF RFC 4180 Common Format for Comma-Separated Values Files
Data Item Reference(s)	<p>Data Items:</p> <p>Device ID Device Type Description Reading Date</p>

	Period ID Advance Current Date Meter register ID Register reading Calorific value PTZ conversion factor Tariff indicator Time band name Block element name Tariff rate Action DateTime Action Type Action Source Action Value Char Customer Start Date.
Security Requirement(s)	SP.31, SP.54
Component(s) affected	Consumer Interface Device (via H2/GB4 interface), Electricity Meter, Communications Module (gas meter mirror)

Prepayment and Credit Requirements

1.100. The prepayment and credit functional requirements define a common level of functionality associated with credit tariffs and prepayment, including operation in the event of WAN not being available.

Prospectus Requirement	The Smart Metering System shall be remotely switchable between prepayment and credit mode of operation.
ID	PC.1
Extended Requirement	<p>PC.1.1 The Smart Metering System shall be able to switch between prepayment/PAYG and credit mode of operation remotely or locally by authorised personnel at any time (e.g. HHT and DCC/Headend).</p> <p>PC.1.2 The Smart Metering System shall clearly display the current mode of operation (e.g. Credit Mode).</p> <p>PC.1.3 The Smart Metering System shall be capable of being switched between prepayment/PAYG and credit mode immediately or at a future date and time.</p> <p>PC.1.4 On receipt of a mode of operation change command the Smart Metering System shall:</p> <ul style="list-style-type: none"> • Validate the command and acknowledge back to the DCC/Headend • Reject if invalid or unable to complete giving a rejection reason • Acknowledge receipt if future dated <p>PC.1.5 A mode of operation change(to pre-pay/PAYG) command should have, but not be limited to, the following data items:</p> <ul style="list-style-type: none"> • Initiate Emergency Credit on switch or Vend Code (for the purpose of ensuring that the consumer is not disconnected) • Emergency Credit settings • Non-Disconnect settings and Debt recovery settings as detailed in PC.04 • Date and time of mode switch (if applicable) <p>PC.1.6 The Smart Metering System shall record mode of operation changes in the event log(s), as described in DI.1.</p> <p>PC.1.7 The Smart Metering System shall not interrupt the consumer's supply during the process of changing the mode of operation.</p> <p>PC.1.8 When changing mode of operation(to pre-pay/PAYG), the Smart Metering System shall invoke emergency credit automatically, or apply a credit balance if a valid vend code is also provided with the mode of operation change command in order to prevent interruption to the consumer's supply.</p> <p>PC.1.9 The Smart Metering System shall record data (Please see PC.1.11 below) when a change of mode of operation is made.</p> <p>PC.1.10 When changing to credit mode from prepayment mode, the Smart Metering System shall record the outstanding credit and debt balances as per PC.7 (i.e. stored for 3 months).</p> <p>PC.1.11 Snapshot information shall be stored by the Smart Metering System and made available remotely to the DCC/Headend. Snapshot information shall include, but not be limited to, the following data:</p> <ul style="list-style-type: none"> • Snapshot Date/Time • Mode of operation change type • All Account Balances (e.g. Credit Balance, Debt etc.) • All Register Readings (Rate Registers 1 to n, Total Energy Register etc).

	<p>PC.1.12 When switched to credit mode from prepayment/PAYG mode, only credit mode data shall be available remotely or locally on all devices (e.g. no prepayment display screens on meters and IHDs).</p> <p>PC.1.13 It shall be possible to remotely cancel a future dated request to switch mode of operation.</p> <p>PC.1.14 If the energy supply is interrupted prior to a mode of operation change, the meter(s) shall follow the requirements set out in ES.1 and GS.5 respectively.</p> <p>PC.1.15 Where a mode of operation change has been scheduled for a date/time in the future this shall not change any of the active settings on the meter until the specified date and time.</p> <p>PC.1.16 The Smart Metering System shall be able to make sensitive data, such as debt balances, unavailable on remote command.</p>
Extended Narrative	Allows payment options to be remotely configurable without the need for a visit to the consumer's premises.
Justification	High-level list F
Domestic/Non-domestic	D/ND
Use Case(s)	UC13.01 and UC13.02
Normative Reference(s)	N/A
Data Item Reference(s)	N/A
Security Requirement(s)	N/A
Component(s) affected	N/A

Prospectus Requirement	The Smart Metering system shall support prepayment mode of operation via remote top-ups.
ID	PC.2
Extended Requirement	PC.2.1 The Smart Metering System shall support prepayment mode of operation via remote top-ups.
Extended Narrative	This requirement is no longer relevant. Please refer to PC.11 where functionality is defined.
Justification	High-level list C
Domestic/Non-domestic	D/ND
Use Case(s)	N/A
Normative Reference(s)	N/A
Data Item Reference(s)	N/A
Security	N/A

Requirement(s)	
Component(s) affected	Meter

Prospectus Requirement	The Smart Metering System operating in prepayment mode shall support remote configuration of emergency/friendly credit.
ID	PC.3
Extended Requirement	<p>PC.3.1 The Smart Metering System operating in prepayment mode shall support remote configuration of emergency/friendly credit.</p> <p>Emergency Credit</p> <p>PC.3.2 It shall be possible for Authorised Parties to remotely or locally amend the amount of emergency credit available for selection.</p> <p>PC.3.3 The Smart Metering System shall support the remote and local configuration by Authorised Parties of an emergency credit value for meters operating in PAYG/prepayment mode.</p> <p>PC.3.4 The minimum allowable value for emergency credit shall be 0.00 and the maximum value 1000.00 and shall be displayed in the currency the meter is configured to operate in (e.g. pounds or Euros). When configured as 0.00 the meter shall not make the emergency credit available for selection at any time.</p> <p>PC.3.5 It shall be possible to configure the emergency credit value as part of configuring a change of the operating mode of the meter to PAYG.</p> <p>PC.3.6 It shall be possible to automatically invoke the emergency credit as part of configuring a change of operating mode to PAYG.</p> <p>PC.3.7 Once invoked, the emergency credit shall only be made available for selection again once the full amount of any emergency credit used and any unpaid standing charges (as described in requirement PC.4.17) have been fully repaid.</p> <p>PC.3.8 It shall be possible for Authorised Parties to remotely or locally configure a threshold (Low Credit Threshold) to be measured against the Meter Balance which will determine when the emergency credit can be invoked. Once the balance equals or falls below this threshold the Smart Metering System shall provide an audible alert and a visual indicator to make the consumer aware that the emergency credit is now available for selection.</p> <p>PC.3.9 It shall be possible for the consumer to mute the audible alert, either through a direct interaction with the meter or via a message sent over the SM HAN, without having to invoke the emergency credit.</p> <p>PC.3.10 Once the emergency credit has been made available for selection, if the consumer makes a payment and the Meter Balance rises above the Low Credit Threshold without the emergency credit being selected, any visual indicators that were provided to indicate that emergency credit was available will no longer appear on the display.</p> <p>PC.3.11 When the emergency credit is invoked the Smart Metering System shall provide a clear visual indicator to the consumer to let them know that they have successfully selected the emergency credit.</p> <p>PC.3.12 When the emergency credit is in use, the Smart Metering System shall provide the consumer with a clear indication of, the following information:</p> <ul style="list-style-type: none"> • Confirmation that the emergency credit is in use • The amount of emergency credit left to be used • The amount owed (this is the amount that needs to be repaid, including standing charges, unpaid debt etc.) before the emergency credit becomes available for

	<p>selection again.</p> <p>PC.3.13 When the emergency credit is invoked before the Meter Balance reaches the local disablement threshold for insufficient credit, and once the Meter Balance reaches this threshold the supply shall not be interrupted. The meter shall provide a clear indication that the emergency credit is now in use.</p> <p>PC.3.14 If the emergency credit is invoked after the meter has been locally disabled due to insufficient credit, the meter shall become locally enabled and the full amount of emergency credit shall be made available for use. Any unpaid charges accrued during the period when the supply was locally disabled shall not be deducted from the emergency credit that is available.</p> <p>PC.3.15 When the configured emergency credit value has been fully used the meter shall be locally disabled and the consumer shall be provided with a clear indication on the display that the emergency credit has been used and of the total amount of credit that shall need to be added to the meter before the supply is locally enabled.</p> <p>PC.3.16 Once it has been made available for selection, it shall be possible to invoke the emergency credit at any time through a direct interaction with the meter's user interface or via a message sent over the SM HAN (either through a device connected to the SM HAN or a remote Command from the supplier).</p> <p>PC.3.17 When the emergency credit is invoked it shall be logged by the Smart Metering System as per DI.1</p> <p>PC.3.18 The Smart Metering System shall make available the following emergency credit data to the SM HAN :</p> <ul style="list-style-type: none"> • Whether emergency credit is available for selection • Whether emergency credit is in use • Whether emergency credit has been fully used • The amount that needs to be repaid before emergency credit becomes available again • Non-disconnect Settings (Friendly Credit) <p>PC.3.19 It shall be possible for Authorised Parties to remotely or locally configure times (non-disconnect periods) where PAYG local disablement rules shall be suspended and the supply shall not be interrupted, even if the Meter Balance falls below the configured local disablement threshold.</p> <p>PC.3.20 It shall be possible for these non-disconnect periods to be configured as a combination of the following:</p> <ul style="list-style-type: none"> • Start and end time (HH:MM:SS) - These will be applied to every day in addition to settings below • Day of the week (for example every Tuesday) (1-7 Monday=1, Tuesday=2 etc.) • Specific dates (DD:MM:YYYY) up to a maximum of 10 dates • Seasonal start and end dates (DD:MM) up to a maximum of 10 seasonal periods (seasonal means any period greater than one day). (For example every day between Good Friday and Easter Monday). <p>PC.3.21 Where specific dates are specified as part of the configuration of a non-disconnect period, the local PAYG disablement rules shall be suspended at 00.00.00 on the start date and will resume at 23.59.59 on the end date, provided no other non-disconnect periods are in force.</p> <p>PC.3.22 When a seasonal non-disconnect period is being configured the meter shall validate the request to ensure that the end date of the season is later than the start date.</p> <p>PC.3.23 Where multiple non-disconnect periods have been configured the meter shall always apply the setting which shall result in the longest non-disconnect period being applied. (For example, if start and end times of 19:00:00 and 08:00:00 are in force and a non-disconnect date has also been specified, when the meter reaches the end of the non-disconnect date suspension of the local disablement rules shall not be lifted. The suspension shall continue until 08:00:00 the following morning).</p>
--	---

	<p>PC.3.24 It shall be possible to use the non-disconnect settings to configure meters operating in PAYG mode in such a way that the supply is never interrupted.</p> <p>PC.3.25 When the Meter Balance falls below the local disablement threshold during a non-disconnect period the meter shall provide a clear visual indicator that the non-disconnect setting is in operation.</p> <p>PC.3.26 During non-disconnect periods, meters operating in PAYG mode shall continue to manage the Meter Balance in accordance with the configured tariff and debt settings.</p> <p>PC.3.27 Audible alerts directly related to the Meter Balance threshold shall automatically be suppressed during non-disconnect periods. The suppression of audible alerts during non-disconnect periods shall not prevent the provision of visual alerts or the logging of the associated event.</p> <p>PC.3.28 When the end of a configured non-disconnect period is reached and the supply is to be interrupted due to insufficient credit being available, the Smart Metering System shall provide visual and audible alerts and the interruption shall be suspended for a further period of ten minutes. If no payments are applied to the meter during this ten minute period, or if insufficient credit is added, then at the end of this ten minute period a brief warning will be provided and the supply will then be interrupted.</p> <p>PC.3.29 All non-disconnect alerts and alarms shall be made available to the SM HAN.</p> <p>PC.3.30 It shall be possible for meters to operate in PAYG mode without any non-disconnect settings being configured.</p>
Extended Narrative	<p>Continuity of supply in pre-payment mode when the credit balance reaches zero, is provided by the ability of suppliers to configure:</p> <p>The start/end times, days and/or dates on which the Smart Meter will not self-disconnect</p> <p>The credit amount below which emergency credit is available and the amount that will be provided</p>
Justification	Consumer
Domestic/Non-domestic	D/ND
Use Case(s)	<p>Relevant use cases:</p> <p>UC02.04 Display PAYG information</p> <p>UC02.08 Self-disconnect supply</p> <p>UC02.10 Manage PAYG - Set Parameters</p> <p>UC29.01 Reconnect supply</p>
Normative Reference(s)	BS EN 62055-31 partial
Data Item Reference(s)	<p>Prepayment Data, in particular:</p> <p>Emergency Credit Amount</p> <p>Emergency Credit Charges</p> <p>Emergency Credit Status</p> <p>Non-Disconnection Day ID</p> <p>Non-Disconnection Period Charges</p> <p>Non-Disconnection Period End Date</p> <p>Non-Disconnection Period End Time</p> <p>Non-Disconnection Period Start Date</p> <p>Non-Disconnection Period Start Time</p>

	Non-Disconnection Special Date Threshold High Limit Threshold Low Limit Threshold Type
Security Requirement(s)	N/A
Component(s) affected	Electricity Meter

Prospectus Requirement	The Smart Metering System operating in prepayment mode shall support remote configuration of debt recovery.
ID	PC.4
Extended Requirement	<p>PC.4.1 The Smart Metering System operating in prepayment mode shall support remote configuration of debt recovery.</p> <p>PC.4.2 It shall only be possible to add/adjust debt settings to meters that are operating in PAYG mode or are being commissioned to operate in PAYG mode.</p> <p>PC.4.3 There shall be a minimum of two ways in which debt/charge recovery can be configured to operate:</p> <p>Time based debt/charges recovery:</p> <p>PC.4.4 The meter shall be capable of being configured to recover debt/charges at a configurable frequency (e.g. each minute, hourly, daily, weekly, monthly etc.).</p> <p>PC.4.5 The meter display can be configured by suppliers to show the recovery amount as an hourly, daily, weekly or monthly value independent of the specified collection frequency for that debt type (e.g. the meter may be configured to recover the debt/charge every minute but the recovery rate is shown as a weekly figure).</p> <p>Payment based debt/charges recovery:</p> <p>PC.4.6 The meter shall be capable of being configured to recover a percentage from each payment that is applied to the meter, up to a maximum recovery rate over a configurable time period (e.g. recover 50% from each payment up to a maximum of £7.00 per week. Following this example, if the consumer made a payment of £10 and another payment of £15 during the course of a week it would deduct £5 from the first payment and £2 from the second payment.) For further clarification see Extended Narrative later in this document.</p> <p>PC.4.7 There shall be a minimum of three categories of debt or charges that can be managed by the meter.</p> <p>PC.4.8 The three categories of debt or charges shall be clearly displayed to the consumer with sufficient information within the display indicators, to indicate what charges have been added to the Smart Metering System.</p> <p>PC.4.9 The debt indicators shall be fully configurable and the Smart Metering System shall have a minimum capability to allow for values up to 18 alphanumeric characters. (These indicators shall be available on the meter display for each debt category and, where the number of characters exceeds the static display capabilities of the meter, the meter shall automatically scroll the indicator so that all of the information it contains can be viewed whenever the relevant screen is accessed by the consumer.)</p> <p>PC.4.10 A priority rating shall be allocated to each debt or charge, as part of the configuration, to determine the order in which they are collected from the Meter</p>

	<p>Balance and/or payments.</p> <p>PC.4.11 Each of the three debt/charge categories can be independently configured to operate in either of the two payment recovery modes.</p> <p>PC.4.12 The individual debt data items shall be capable of being adjusted independently from any other PAYG or debt related data items (e.g. weekly recovery rate can be changed without need to alter the total debt amount).</p> <p>PC.4.13 It shall be possible to adjust future date debt/charge settings and values by adding to, subtracting from, or setting the absolute value (i.e. previous value is overwritten by new value).</p> <p>PC.4.14 On receipt of a future dated Command to adjust debt/charge settings the meter shall store this and shall not make any adjustments to the debt/charge settings until the time and date specified in the Command.</p> <p>PC.4.15 For every time a debt payment is recovered, the debt payment value shall be decremented from the outstanding total debt value and incremented to the debt paid value for the corresponding debt category (as per requirement PC.6).</p> <p>PC.4.16 The Smart Metering System shall be configurable to allow the consumer to increase and decrease the recovery rate above the supplier minimum specified value, via an authorised SM HAN device.</p> <p>PC.4.17 For the purposes of all payment based debt/charge calculations the meter collection week shall commence at 00.00.00 hours every Monday and finish at 23.59.59 hours every Sunday.</p> <p>PC.4.18 The following are the minimum and maximum values that the meter should allow for each of the configurable collection rates:</p> <p>Min/max configurable values</p> <ul style="list-style-type: none"> • Type 1, 2 & 3 Total Debt/Charges – minimum value = 0.00, maximum value = 99,999.99 or Null. • Type 1,2 & 3 Recovery Amount- minimum value = 0.00, maximum value = 99,999.99 • Type 1,2 & 3 Recovery Rate – minimum value = 0%, maximum value = 100% <p>PC.4.19 The meter shall allow all financial debt values to be added / adjusted in currency units to two decimal places (e.g. pounds and pence).</p> <p>PC.4.20 The meter shall support the capability to remotely, or locally through an Authorised Party, choose if the programmed debt values continue to decrement the balance in the following circumstances:</p> <ul style="list-style-type: none"> • When the emergency credit is in use • When the supply has self-disconnected due to a lack of credit <p>PC.4.21 Recovery of debt and recovery of standing charge shall share the following requirements:</p> <ul style="list-style-type: none"> • Assignment of a collection priority rating (to be used in conjunction with the debt type priority ratings) to determine the order in which decrements are made from the Meter Balance. • Configuration of collection frequency (how often standing charge payments are deducted from the Meter Balance). • Display of standing charge value as a daily, weekly or monthly figure independent of the collection frequency • Is standing charge collected when using emergency credit (Y/N?) • Is standing charge collected when supply has self-disconnected (Y/N?) • The minimum and maximum allowable values for the standing charge are the same as the min/max values for the Recovery Amount.
--	---

PC.4.22 If the meter has been configured not to collect standing charges when emergency credit is in use, the meter shall maintain, in a separate register, the value of the standing charges that would have otherwise been collected during this period. The meter shall ensure that this amount is repaid in full before emergency credit is made available for use again.

PC.4.23 On receipt of a debt modification request where the effective date and/or time associated with that request is in the past, or no date/time has been specified, then the meter shall process the instruction and apply the specified settings with immediate effect.

PC.4.24 Where the "total debt value" for a debt/charge category reaches zero the meter shall take the following actions for that debt category:

- Automatically stop collecting any further payments.
- Reset the debt collection rates to zero
- Display a message that the debt/charge category is no longer being collected, which shall be cleared when the consumer interacts with the meter or after a period of 24 hours if no interaction occurs during that period
- Display only the debt indicator and debt paid fields for that category.

PC.4.25 Any request which contains values which are outside the minimum or maximum values specified above shall be rejected by the meter with no alteration to the existing values for the debt settings.

PC.4.26 When operating a payment based recovery mode the total of all three debt category recovery rate percentages shall not exceed 100%.

PC.4.27 The meter shall be configurable to allow suppliers to choose if the collection of individual programmed debt values (Type 1, 2 or 3) takes priority over the collection of any debt accrued for emergency credit and standing charge usage. It shall be possible to configure this differently for the individual debt/charge categories.

PC.4.28 Where a change to the debt settings has been scheduled for a date/time in the future the meter shall allow the scheduled change to be cancelled without impacting any of the existing debt settings.

PC.4.29 Where the meter receives a request to amend the values associated with a particular debt type, if the meter already holds such a request, then provided the new request complies with the requirements of PC4, the meter shall cancel the scheduled change and replace it with the new request.

PC.4.30 Where more than one debt/charge type is in use it shall not be possible to have different recovery amount frequencies for the individual debt/charge categories. All of the recovery amount frequencies must be the same (i.e. daily, weekly or monthly).

PC.4.31 If the meter is configured to deduct a sum directly from any payment applied to the meter the amount deducted shall be clearly displayed on the meter when the payment is applied.

PC.4.32 Whenever an adjustment to the debt settings is implemented the meter shall provide a notification on its display advising that an adjustment has taken place. This notification shall be displayed until the first time the consumer interacts with the meter or until the specified time out period has elapsed.

PC.4.33 The meter shall support the capability to remotely or locally (through an HHT) specify the order in which the debt screens appear in the meter display cycle.

PC.4.34 When a debt is programmed, the meter it shall be capable of displaying the associated values during its display cycle.

PC.4.35 As part of its display the meter shall be capable of providing a clear indication of the collection frequency associated to a particular recovery value (weekly, monthly, from each payment etc.)

PC.4.36 The meter display shall be capable of clearly displaying the individual collection rates associated with each debt type in its display cycle.

	<p>PC.4.37 Where collection rates for different debt categories have the same collection frequency (e.g. weekly, monthly etc.) the meter shall display the aggregated value of those rates.</p> <p>PC.4.38 Where there are no configured debt settings, or where privacy settings have been enabled, debt information shall be excluded from the meter’s display cycle.</p> <p>PC.4.39 The following Smart Metering System data items shall be available to the SM HAN:</p> <ul style="list-style-type: none"> • Total debt/charges outstanding • Recovery amount • Recovery frequency • Debt/charges indicator • Aggregated recovery rates • Aggregated total debt value • Total amount paid for each debt/charge type • Notification of any debt adjustments • Any visual alerts which appear on the meter. <p>PC.4.40 The meter shall log any changes that are made to any of the debt settings and take a full snapshot of PAYG information when the change is applied. As part of this logging process the meter shall record:</p> <ul style="list-style-type: none"> • The date and time of the change • The type of change that is implemented • All debt settings prior to change • All debt settings following the change • Meter balance at point of change • Register readings • Local or remote change. • Failed attempts to change any debt/charge values. <p>PC.4.41 It shall be possible to set the “total debt value” field to “null”. The Smart Metering System for this configuration shall then:</p> <ul style="list-style-type: none"> • Continue to deduct the recovery amount from the Meter Balance in line with PC4.15 and PC4.16 • Not decrement from the “total debt value” field –(is a variation to PC4.11) • Only displays the recovery amount, recovery frequency and debt/charge indicator fields on the Smart Meter.
Extended Narrative	<p>Note PC.4.5 - Recovery directly from payments does not mean that the meters will be expected to replicate the debt functionality provided by gas Quantum meters in this mode. There will be no need to set both minimum and maximum recovery rates and there is no requirement for the meter to be able to “catch up” when the set weekly recovery rate has not been collected.</p>
Justification	Consumer
Domestic/Non-domestic	D/ND

<p>Use Case(s)</p>	<p>The details captured as part of this requirement are linked to the following use cases:</p> <p>The Use Cases below are directly linked to the ability to amend debt setting information:</p> <p>UC 2.05 Manage PAYG – Adjust Balances UC 2.1 Manage PAYG – Change Parameters</p> <p>Configuration of debt/charge recovery settings could also be done in conjunction with the following Use Case:</p> <p>UC 13.01 Switch between Credit and PAYG - Switch to PAYG</p> <p>The following Use Case will use the rules defined as part of this requirement to decrement debt repayments from the Meter Balance:</p> <p>UC 2.03 Manage PAYG – Decrement Balance</p> <p>The following Use Case deals with the requirement to display debt related information on the meter display:</p> <p>UC 2.04 Manage PAYG – Display PAYG Information</p> <p>The Use Case below deals with the provision of debt related information to additional display devices</p> <p>UC 19 – Provide update to display</p> <p>This Use Case would be used to define (if required) the full repayment of debt as an event and specify the message displayed to the consumer when debt collection ceases</p> <p>UC 4.01 – Manage Events – Set event parameters and rules</p> <p>This Use Case would be used to request debt related information stored in the meter log:</p> <p>UC 10 – Check status and settings of SMS component</p> <p>The following Use Cases would also be utilised as part of the process to retrieve debt information (current value of total debt etc.) from the meter, either as separate data or as part of</p> <p>UC 9.01 – Read Meter – On demand UC 9.02 – Read Meter – Historical reads UC 9.03 - Read Meter – Schedule ad hoc reads UC 9.04 Read Meter – Schedule and capture regular readings</p>
<p>Normative Reference(s)</p>	<p>BS EN 62055-31 partial</p>
<p>Data Item Reference(s)</p>	<p>Data Items</p> <p>The following are the potential data items that may be passed to the meter as part of</p>

	<p>the process to change/amend debt settings:</p> <p>Debt/charges collection priority (1, 2, 3 etc.)</p> <p>Debt /charges label (Energy debt, Green Deal charges etc.)</p> <p>Debt/charges type/level (1, 2 or 3?)</p> <p>Collection priority (the order in which the debt type is to be decremented from the Meter Balance)</p> <p>Total debt/charge amount</p> <p>Recovery Amount</p> <p>Recovery amount indicator (Definition of how often the specified recovery amount is to be collected from the meter)</p> <p>Recovery Rate (Hourly, Weekly, Monthly etc.) indicator (The frequency at which the debt is to be decremented from the Meter Balance)</p> <p>Recovery Method (Decrement from balance, deduct from payment) indicator</p> <p>Payment recovery percentage (the maximum percentage that will be recovered from a payment for each debt type)</p> <p>Consumer adjustable parameter (Yes or No indicator)</p> <p>Recovered from Meter Balance during emergency credit operation indicator</p> <p>Recovered from Meter Balance during self-disconnection indicator</p> <p>Adjustment type (add, subtract or set) indicator</p> <p>Aggregated total debt value</p> <p>Aggregated recovery amount</p> <p>Standing charge collection priority</p> <p>Standing charge collection frequency</p> <p>Standing charge amount</p> <p>Standing charge amount indicator (indication of how often the standing charge is to be collected from the meter).</p> <p>Debt repaid value (the amount of each debt type that has been repaid by the consumer).</p>
Security Requirement(s)	It shall only be possible to amend or set the debt settings with the appropriate authorisation.
Component(s) affected	Electricity Meter, gas meter & Mirror, HAN, WAN

Prospectus Requirement	The Smart Metering System operating in prepayment mode shall be capable of maintaining supply to premises independent of WAN communications.
ID	PC.5
Extended Requirement	PC.5.1 The Smart Metering System operating in prepayment mode shall be capable of maintaining supply to premises independent of WAN communications.
Extended Narrative	This requirement is no longer relevant. Please refer to PC.10 where functionality is defined.
Justification	Consumer
Domestic/Non-domestic	D/ND
Use Case(s)	N/A
Normative Reference(s)	N/A

Data Item Reference(s)	N/A
Security Requirement(s)	N/A
Component(s) affected	Meter

Prospectus Requirement	<p>The Smart Metering System shall store the history of the last 10 debt payments (of each type) from the Meter Balance/vend and synchronise this data with the head-end system.</p> <p>The payment history shall be retained in the Smart Metering System and be capable of being displayed locally and shall, as a minimum, include the last five top-ups in prepayment/PAYG mode with amount, dates and times.</p>
ID	PC.6
Extended Requirement	<p>PC.6.1 The Smart Metering System shall store and display a customer's debt/charge information.</p> <p>PC.6.2 The storage and display of debt/charge information shall be as defined in PC.4.</p> <p>PC.6.3 The storage and display of consumer payments information shall be as defined in PC10.</p> <p>PC.6.4 The Smart Metering System shall provide a view of debt/charge setting information on the meter display.</p> <p>PC.6.5 The Smart Metering System shall clearly indicate during its display cycle when the debt/charge setting information begins and ends.</p> <p>PC.6.6 The Smart Metering System shall provide the consumer with a means of returning the display to its default screen following an interaction.</p> <p>PC.6.7 The Smart Metering System shall automatically return the display to its default screen after a defined "time out" period if the display cycle is not completed.</p>
Extended Narrative	
Justification	Consumer
Domestic/Non-domestic	D/ND
Use Case(s)	<p>The details captured as part of this requirement are linked to the following use cases.</p> <p>The use cases below are directly linked to the ability to amend debt setting information:</p> <p>UC 2.05 Manage PAYG – Adjust Balances UC 2.1 Manage PAYG – Change Parameters</p> <p>The following use case will use the rules defined as part of this requirement to decrement debt repayments from the Meter Balance:</p> <p>UC 2.03 Manage PAYG – Decrement Balance</p> <p>The following use case deals with the requirement to display debt related information</p>

	<p>on the meter display:</p> <p>UC 2.04 Manage PAYG – Display PAYG Information</p> <p>The use case below deals with the provision of debt related information to additional display devices:</p> <p>UC – Provide update to display</p> <p>This use case would be used to define (if required) the full repayment of debt as an event and specify the message displayed to the consumer when debt collection ceases:</p> <p>UC 4.01 – Manage Events – Set event parameters and rules</p> <p>This use case would be used to request debt related information stored in the meter log:</p> <p>UC 10 – Check status and settings of SMS component</p> <p>The following use cases would also be utilised as part of the process to retrieve debt information (current value of total debt etc.) from the meter, either as separate data or as part of:</p> <p>UC 9.01 Read Meter – On demand</p> <p>UC 9.02 Read Meter – Historical reads</p> <p>UC 9.03 Read Meter – Schedule ad hoc reads</p> <p>UC 9.04 Read Meter – Schedule and capture regular readings.</p>
Normative Reference(s)	IEC 62055-21
Data Item Reference(s)	<p>Data Items</p> <p>The following are the potential data items that may be passed to the meter as part of the process to change/amend debt settings:</p> <p>Total charge amount Total Recovery Amount Total Remaining charge Remaining Charge 1 – Rate Remaining Charge 2 – Rate Remaining Charge3 - Rate Charge Recovered from Meter Balance during emergency credit in operation flag. Recovered from Meter Balance during non-disconnect period flag Recovered from Meter Balance during self-disconnection. Recovered from Meter Balance during load-limit period indicator Adjustment type (add, subtract or set) indicator</p>
Security Requirement(s)	It shall only be possible to amend or set the debt settings with the appropriate

	<p>authorization.</p> <p>Possible privacy requirements.</p> <p>Generic requirements around protection of data items (obfuscation/encryption/signatures etc)</p>
Component(s) affected	All SMS Components

Prospectus Requirement	The Smart Metering System shall store data used for billing and settlement purposes for at least 3 months.
ID	PC.7
Extended Requirement	PC.7.1 The Smart Metering System shall store electricity import and export and gas data used for billing and settlement purposes for at least three months.
Extended Narrative	This allows for Authorised Parties to have a three-month opportunity to re-retrieve billing and settlement data.
Justification	High-level list A
Domestic/Non-domestic	D/ND
Use Case(s)	The requirement is non-functional but the data would be retrieved in UC 09.02
Normative Reference(s)	None known
Data Item Reference(s)	None
Security Requirement(s)	SP.17, SP.22
Component(s) affected	SMS Components only

Prospectus Requirement	The Smart Metering System shall support real time remotely configurable tariff structures.
ID	PC.8
Extended Requirement	<p>PC.8.1 The Smart Metering System shall support real time remotely configurable tariff structures.</p> <p><u>Electricity</u></p> <p>PC.8.2 The meter shall support import and export tariffs. This shall include all existing tariff types and future tariff types.</p> <p>PC.8.3 The meter shall support TOU tariffs, accommodating a structure of up to (48 (TOU) x1) for supplier import tariffs.</p> <p>PC.8.4 The meter shall support a combined Time of Use & Block tariff structure, up</p>

to (8 TOU x 4 Block) and three threshold levels for supplier import tariffs. See PC.8.42 for further clarification.

PC.8.5 The tariff structure applicable to the TOU structure on the first element shall support:

- Three seasons (minimum)
- Three week profiles (minimum)
- Six day profiles associated with week profile i.e., weekday, weekend only (minimum)
- Twelve switching points per day (minimum)
- Ten day profiles to be used with Special Days
- 50 Special Day dates An export tariff and supporting registers which are defined in "Export Tariff structure" below.
- Export measurement capability

PC.8.6 A twin element meter shall have separate tariff structures on each element.

The second element shall have a separate configuration from the first element.

PC.8.7 Twin element tariff structures shall form part of the import tariff requirements for the Smart Meter. For such tariff arrangements, the second element structure shall include:

- TOU only
- Up to four rates (inc CPP)
- No block structure is required on the second element
- An export tariff and supporting registers which are defined in "Export Tariff structure" below.
- Export measurement capability

PC.8.8 The TOU tariff structure of the second element shall support:

- Three season profiles (minimum)
- Three week profiles (minimum)
- Two day types (per week profile)
- Twelve switching points per day (minimum)
- Ten day profiles to be used with Special Days (can have up to 50 dates across the Special Day profiles)
- 50 Special Day dates.

Critical Peak Pricing (CPP)

PC.8.9 Critical Peak Pricing (CPP) tariffs shall be supported by the meter.

PC.8.10 A separate register(s) shall be required to accommodate the CPP tariffs, these registers will be included within the (48x1) TOU or (8x4) TOU/block structures (block shall be set to zero), and therefore no additional registers are required.

PC.8.11 A CPP event can be:

- A. future dated by setting a CPP profile on selected registers for the required period (hours/days), or
- B. actioned on an ad hoc basis.
 - For either a type (a) or type (b) CPP event the CPP tariff rate shall be accommodated within the defined import tariff structures (48x1 or 8x4) where 1 or more registers are used to support CPP.
 - A Special Day type trigger for the CPP event shall be sent (at any point during the day) by the supplier. The actual CPP event can only start on the half hour boundary. The CPP event period will be defined within the

terms of the tariff arrangements set by the supplier. The CPP event shall override the tariff rate used. Immediately after the CPP period ends, the tariff should revert to that applicable at the current date and time.

PC.8.12 The meter shall be capable of accepting a command to react as soon as possible (i.e. at next HH boundary) if so configured, or to a future -dated CPP day profile.

PC.8.13 The Smart Metering System shall support the messaging required for suppliers and consumers to over-ride a CPP event, see narrative for CPP override.

PC.8.14 CPP events shall include both price increases and reductions.

Load Limiting Monitoring

PC.8.15 The meter shall support load limiting using counters on the meter to count instances where the power threshold is breached for longer than thirty seconds. This measurement shall be done in the meter and visible on the display of the meter, as well as available remotely via DCC / Headend.

Two counters are required:

1 x cumulative counter – range [0-99] (which resets to zero when it's limit is reached)

1 x resettable cumulative counter range [0-99] which shall be reset as per supplier requirement (this can be on the billing period).

The log of the last ten events that breach the threshold shall be date and time stamped.

The resettable cumulative counter can be configurable to set for time periods within a day e.g. 15:00 to 17:00

The meter shall support auto reset as per billing period or as required by the supplier. This will reset the cumulative counter.

PC.8.16 In response to the load limiting event, the contactor shall be configurable to be open or shut, ES.12 refers.

Real Time Pricing (RTP)

PC.8.17 The Smart Metering System shall support real time pricing .

RTP is defined as dynamic pricing which is used to reflect the changing wholesale price of electricity.

PC.8.18 There shall be no limit to the number of configuration changes (day types) that can be received from DCC/Headend in a given period.

PC.8.19 The meter shall support a minimum of twelve switching signals per day, and the meter shall renew the twelve signal limit on receipt of a new day type configuration.

PC.8.20 The Special Day profile shall be able to be defined during the day that real time pricing is to commence.

Export Tariff Structure

PC.8.21 For export (supplier) tariffs, the meter shall support a 4 rate (including 1 rate for CPP) TOU only structure (i.e. no blocks).

PC.8.22 Export TOU shall accommodate up to:

- Two season profiles
- Two week profiles
- Four day profiles (two per week)
- One Special Day profile

Gas (import)

PC.8.23 The gas meter tariff structure shall support:

- Two season profiles
- Two week profiles
- Four day profiles (2 per week)
- Two Special Day profiles

PC.8.24 The gas meter shall support 50 dates for Special Day profiles (as per electricity requirements); and Special Days can also be used on an ad hoc basis (as per electricity CPP requirements).

PC.8.25 Gas TOU bands shall have a minimum resolution of one day (i.e. TOU bands will be one or more whole days, no narrower - e.g. TOU can be applied to whole days only).

PC.8.26 Block thresholds (three threshold levels) can change the rate within a day.

PC.8.27 Up to four blocks shall be possible. Each block shall work in the same way as electricity blocks and can be reconciled and reset on a minimum granularity of one day.

Gas & Electricity

PC.8.28 Tariff and price updates shall commence from the Effective From Date and Time (DD/MM/YYYY HH:MM).

PC.8.29 A snapshot of billing data, cumulative registers, and TOU/Block registers shall be captured when a new tariff or price becomes effective. An event shall be recorded as per DI.01.

PC.8.30 The Smart Metering System shall be capable of receiving the next tariff update in advance and applying the changes when the Effective From Date and Time condition is met. The meter shall be capable of receiving a cancellation of a future dated tariff.

PC.8.31 Each register and appropriate tier threshold/block shall be clearly labelled with a configurable identifier and shall meet the requirements of DS.09.

PC.8.32 The meters shall be capable of supporting the display of a standing charge.

PC.8.33 The meter shall be capable of applying blocks to a single TOU register, where the consumption accumulation in the single TOU rate applies to the four blocks (three threshold levels). The remaining ToU registers, if in use, shall not have blocks when operating in this configuration.

PC.8.34 The meter shall be capable of applying 4 blocks over any and up to four combined TOU registers (e.g. TOU1 + TOU2 + TOU3 + TOU4). The four blocks (three threshold levels) shall be applied to the consumption accumulated from the (up to) four TOU registers. The remaining TOU registers, if in use, shall not have blocks when operating in this configuration.

PC.8.35 The block reset period shall apply across all TOU rates (i.e. the reset period is shared). This block period (i.e. until block is reset) is configurable and can be daily or a billing period (note: deemed as too complex to have a block period that doesn't match billing or daily; where daily block period is required, it is recommended that the daily block resolution is based on:

[total block kWh threshold for a billing period/ # days in billing period]

PC.8.36 As per PC.07 the Smart Metering System shall store twelve sets (snapshots) of historical data for billing purposes, configurable by, billing period/weekly/monthly/quarterly basis.

These snapshots shall be triggered by:

- Automatic schedule (e.g. monthly/weekly etc)

- An external read request
- Change of tenancy/or supplier
- Price change
- Tariff change
- Mode switch as per PC.01
- Credit top up as per PC.02

PC.8.37 The Smart Metering System shall store daily register reads for seven consecutive days and shall be available for display on the meter and on the SM HAN.

PC.8.38 Up to 200 tariff rate changes per annum shall be supported on the meter. (e.g. (3 seasons x 2 types of day +10 day profiles to be used with Special Days) x 12 (switching times daily) = 192 tariff changes per annum

PC.8.39 TOU tariffs shall use half hourly boundaries for change of tariff rates where the meter system doesn’t interface with a controlled load. In the event of a controlled load the meter shall operate a randomised regime in accordance with ES.13.07.

PC.8.40 The meter shall support tariff rates (price in pence/cents) up to two decimal places.

PC.8.41 In the event of a network supply interruption the meter shall resume operation on the tariff rate applicable at the current date and time immediately following the resumption of the supply. PC.8.40. Tariffs shall be able to be set in UTC or BST but all displays shall be in local time.

PC.8.42 The SMS shall support the following register naming conventions:

- **Electricity Element 1 TOU/Block combined - Import 32 registers**

r_xbL_{xk} Wh	r_xbL_{xk} Wh	r_xbL_{xk} Wh	$r_xbL_{xk}W$ h	r_xbL_{xk} Wh	r_xbL_{xk} Wh	r_xbL_{xk} Wh	r_xb $L_{xk}Wh$
r_xbL_{xk} Wh	r_xbL_{xk} Wh	r_xbL_{xk} Wh	$r_xbL_{xk}W$ h	r_xbL_{xk} Wh	r_xbL_{xk} Wh	r_xbL_{xk} Wh	r_xbL_{xk} Wh
r_xbL_{xk} Wh	r_xbL_{xk} Wh	r_xbL_{xk} Wh	$r_xbL_{xk}W$ h	r_xbL_{xk} Wh	r_xbL_{xk} Wh	r_xbL_{xk} Wh	r_xbL_{xk} Wh
r_xbL_{xk} Wh	r_xbL_{xk} Wh	r_xbL_{xk} Wh	$r_xbL_{xk}W$ h	r_xbL_{xk} Wh	r_xbL_{xk} Wh	r_xbL_{xk} Wh	r_xbL_{xk} Wh

Blocks (BL)
TOU (Rate) x 8

- **Electricity Element 1 TOU (48x1) - Import 48 registers**

r_{1k} Wh	r_{2k} Wh	r_{3k} Wh	r_{4k} Wh	R_{5k} Wh	r_{6k} Wh		$r_{48k}Wh$
----------------	----------------	----------------	----------------	----------------	----------------	--	-------------

- **Electricity Element 2 -Import TOU (4x1)**

	<table border="1"> <tr> <td>r₁ TwkWh</td> <td>r₂ TwkWh</td> <td>r₃ TwkWh</td> <td>r₄ TwkWh</td> <td>r₃ TwkWh</td> </tr> </table>	r ₁ TwkWh	r ₂ TwkWh	r ₃ TwkWh	r ₄ TwkWh	r ₃ TwkWh										
	r ₁ TwkWh	r ₂ TwkWh	r ₃ TwkWh	r ₄ TwkWh	r ₃ TwkWh											
	<ul style="list-style-type: none"> Electricity Export (Element 1 only) - TOU (4x1) <table border="1"> <tr> <td>r₁ EXPkWh</td> <td>R₂ EXPkWh</td> <td>r₃ EXPkWh</td> <td>r₄ EXPkWh</td> <td>r₃ EXPkWh</td> </tr> </table>	r ₁ EXPkWh	R ₂ EXPkWh	r ₃ EXPkWh	r ₄ EXPkWh	r ₃ EXPkWh										
	r ₁ EXPkWh	R ₂ EXPkWh	r ₃ EXPkWh	r ₄ EXPkWh	r ₃ EXPkWh											
<ul style="list-style-type: none"> Electricity (Element 2only) - TOU (4x1) (i.e. replicating element 1 export) <table border="1"> <tr> <td>r₁ EXP TwkWh</td> <td>r₂ EXP TwkWh</td> <td>r₃ EXP TwkWh</td> <td>r₄ EXP TwkWh</td> </tr> </table>	r ₁ EXP TwkWh	r ₂ EXP TwkWh	r ₃ EXP TwkWh	r ₄ EXP TwkWh												
r ₁ EXP TwkWh	r ₂ EXP TwkWh	r ₃ EXP TwkWh	r ₄ EXP TwkWh													
<ul style="list-style-type: none"> Gas TOU/Block combined - 16 registers <table border="1"> <tr> <td>r_x bL_x m3</td> <td>r_x bL_x m3</td> <td>r_x bL_x m3</td> <td>r_x bL_x m3</td> </tr> <tr> <td>r_x bL_x m3</td> <td>r_x bL_x m3</td> <td>r_x bL_x m3</td> <td>r_x bL_x m3</td> </tr> <tr> <td>r_x bL_x m3</td> <td>r_x bL_x m3</td> <td>r_x bL_x m3</td> <td>r_x bL_x m3</td> </tr> <tr> <td>r_x bL_x m3</td> <td>r_x bL_x m3</td> <td>r_x bL_x m3</td> <td>r_x bL_x m3</td> </tr> </table> <p>↑</p> <p>Blocks (BL) TOU (Rate) x 8</p> <p>→</p>	r _x bL _x m3	r _x bL _x m3	r _x bL _x m3	r _x bL _x m3	r _x bL _x m3	r _x bL _x m3	r _x bL _x m3	r _x bL _x m3	r _x bL _x m3	r _x bL _x m3	r _x bL _x m3	r _x bL _x m3	r _x bL _x m3	r _x bL _x m3	r _x bL _x m3	r _x bL _x m3
r _x bL _x m3	r _x bL _x m3	r _x bL _x m3	r _x bL _x m3													
r _x bL _x m3	r _x bL _x m3	r _x bL _x m3	r _x bL _x m3													
r _x bL _x m3	r _x bL _x m3	r _x bL _x m3	r _x bL _x m3													
r _x bL _x m3	r _x bL _x m3	r _x bL _x m3	r _x bL _x m3													
Extended Narrative	<p>All the defined tariffs are based on the European Standard DLMS structure. This must support block structures as well as Time of Use (TOU). The DLMS structure supports variation in season/type of day/switching times for TOU and is being updated to accommodate Blocks. However, this does not presume a solution.</p> <p>A twin element variant of the Smart Meter will require a separate tariff for each element.</p> <p>This requirement covers existing and envisaged future tariffs.</p>															
Justification	High-level list D															
Domestic/Non-domestic	D/ND															
Use Case(s)	UC1: commission SMS UC14: update tariffs															
Normative Reference(s)	MID															

Data Item Reference(s)	To logical entity level, list to be provided by Data Modelling Working Group
Security Requirement(s)	None
Component(s) affected	All SMS Components

Prospectus Requirement	The Smart Metering System operating in prepayment mode shall support local credit top up.
ID	PC.10
Extended Requirement	<p>PC.10.1 The Smart Metering System shall have a 'Local Top Up' mechanism when operating in a prepayment mode and this mechanism shall allow the entry of a Unique Transaction Reference Number (UTRN) to the correct number of digits (e.g. 20).</p> <p>PC.10.2 On input of a Local Top Up UTRN, the Smart Metering System shall immediately validate and authenticate the request to ensure the transaction is from a valid source and has not already been processed, e.g. via Remote Top Up via the DCC. (Covered under PC.11)</p> <p>Validation and authentication of the local top up Command shall confirm:</p> <ul style="list-style-type: none"> • That the meter is operating in PAYG Mode, (and therefore able to process the Command) • That the Command is from a valid party and that the UTRN has not been processed before (i.e. duplicated) • That the meter has not already seen the UTRN in its life, i.e. refurbished, repaired Smart Metering Systems shall not accept repeated or duplicated UTRNs • That the value is formatted correctly. <p>PC.10.3 If the Command cannot be validated and authenticated the Smart Metering System shall log the failure and, where configured to do so, shall return a failure message to the DCC/Headend.</p> <p>PC.10.4 Once the validation checks have been passed, the Smart Metering System shall update the balance table and update the new balance on the meter display.</p> <p>PC.10.5 When calculating the balance the Smart Metering System shall apply the business rules configured by the Supplier i.e. the Smart Metering System shall calculate any charges pertaining to standing charges or other charges that may be recovered through the meter before updating the balance on the meter display;</p> <p>PC.10.6 The Smart Metering System shall reject any local or remote top up Command in instances where the calculation of the revised balance exceeds the credit balance capacity of the meter.</p> <p>PC.10.7 Local top up Command values shall be in £'s and pence (€ / cents) up to two decimal places.</p> <p>PC.10.8 The Smart Metering System shall make available the updated balance for display on an IHD (if present).</p> <p>PC.10.9 The Smart Metering System shall display the time and date that the balance was updated.</p> <p>PC.10.10 The Smart Metering System shall display, the last 5 credits added to the meter for the customer to view including the date and time the credit was added and the UTRN associated with that credit.</p> <p>PC.10.11 - The Smart Metering System log shall record:</p>

	<ul style="list-style-type: none"> • The value of the credit • The time and date it was added to the credit balance • The UTRN • Any values allocated/deducted for debt repayments • The UTRN shall not be deleted from the log. <p>PC.10.12 The Smart Metering System log shall store all credits added to the credit balance.</p> <p>PC.10.13 When a Local Top Up Command is entered and processed successfully the Smart Metering System shall provide a local alert to the customer.</p> <p>PC.10.14 Where the Smart Metering System has self disconnected, and processed a Local Top Up Command, the Smart Metering System shall provide an alert to advise the customer the Command has been processed successfully. If as a result of processing the Local Top Up Command the credit balance is above the disconnection threshold, the alert will advise the customer that the supply may be reconnected. This process is detailed in OP.08.</p> <p>PC.10.15 If the UTRN cannot be validated and authenticated, the Smart Metering System shall display a failure message to the customer, including the failure reason (e.g. invalid UTRN, UTRN already processed, incorrect format, etc.).</p> <p>PC.10.16 The Smart Metering System shall allow only 5 input attempts within a 60 minute period of an unrecognised UTRN before disabling the local entry mechanism for 10 minutes. The Smart Metering System shall display a ‘time out’ message to the customer (definition of a timeout is specific to this function only).</p> <p>PC.10.17 If entry of a UTRN is abandoned part way through then the display shall return after a maximum of 10 minutes to the default display screen.</p> <p>PC.10.18 If the UTRN has been entered and rejected, the Smart Metering System shall allow a back-space, tab or other function so that the user does not need to re-enter the whole 20 digits.</p> <p>PC.10.19 The Smart Metering System shall log the status pre and post application of the credit (i.e. the register reading(s), credit balance, debt balance(s)).</p> <p><u>Gas Specifics</u></p> <p>PC.10.20 The customer will be able to “wake up” the gas meter manually. The gas meter shall wake up and check for Remote Top Up Commands immediately prior to crossing its self disconnection threshold. If no Remote Top Up Commands are discovered, the Smart Metering System shall allow the input of a Local Top Up via a UTRN.</p>
Extended Narrative	These requirements ensure that the Smart Metering System has the ability to locally register credit increments when operating in PAYG mode in the event of a communications failure.
Justification	Consumer Groups
Domestic/Non-domestic	D/ND
Use Case(s)	<p>Relevant Use Cases:</p> <p>Use Case 02.02 Manage PAYG add credit locally v1.0 Use Case 19 – Locally Access Usage Information</p> <p>Associated ESoDR Requirements:</p> <p>PC.11 The Smart Meter System shall support prompt and timely register of remote top ups.</p>

	<p>DI.1 The Smart Metering System shall support logging of meter events. This will include the time and date stamping and recording of the originating device for the event.</p> <p>DI.02 The Smart Metering System shall support remote configuration of logs, alarms and thresholds.</p> <p>PC.02 The Smart Metering System shall support "tokenless" prepayment mode of operation via remote top ups.</p> <p>PC.06 The Smart Metering System shall store the history of the last 10 debts recovered (of each type) from the Meter Balance/vend and synchronise this data with the Head-end system. It shall be possible for a consumer to see the payment history. The payment history retained in meters and being capable of being displayed locally in the meter and IHD shall, as a minimum, include:</p> <ul style="list-style-type: none"> • The last five payments in pre-payment/PAYG mode • Dates, times and amounts associated with the last five payments.
Normative Reference(s)	IEC 62056-61tbd
Data Item Reference(s)	<p>Data Items:</p> <p>Time</p> <p>Date</p> <p>UTRN</p> <p>Vend Amount</p> <p>UTRN Alert – Unauthorised UTRN</p> <p>UTRN Alert – Duplicate UTRN</p> <p>UTRN Alert – UTRN Timeout</p> <p>UTRN Message - Unauthorised UTRN</p> <p>UTRN Message – Duplicate UTRN</p> <p>UTRN Message – UTRN Timeout</p>
Security Requirement(s)	<p>Reference the Smart Metering Security Requirements Document:</p> <p>SP.60</p> <p>SP.61</p> <p>SP.62</p> <p>SP.63</p> <p>SP.64</p> <p>SP.65</p>
Component(s) affected	Electricity Meter, gas meter, IHD, SM HAN

Prospectus Requirement	The Smart Meter System shall support prompt and timely register of remote top ups.
ID	PC.11
Extended Requirement	<p>PC.11.1 The Smart Metering System shall support prompt and timely register of remote top ups.</p> <p>PC.11.2 On receipt of a remote top up Command, the meter shall validate the request to ensure the transaction has not already been processed, e.g. via local top up utilising the Unique Transaction Reference Number (UTRN) (covered under PC.10).</p> <p>PC.11.3 Validation and authentication of the remote top up Command shall confirm:</p> <ul style="list-style-type: none"> • That the meter is operating in PAYG Mode, (and therefore able to process the

	<p>Command).</p> <ul style="list-style-type: none"> • That the Command is from a valid party and that the UTRN has not been processed before (i.e. duplicated). • That the meter has not already successfully processed the UTRN in its life, i.e. refurbished, repaired meters shall not accept repeated or duplicated UTRNs; and • That the value is formatted correctly. <p>PC.11.4 If the Command cannot be validated and authenticated the meter shall immediately return a rejection.</p> <p>PC.11.5 On successful validation of the Command, the meter shall update the Meter Balance on the display and this information shall be made available to the SM HAN.</p> <p>PC.11.6 When calculating the balance the meter shall apply the business rules configured by the supplier (specified in PC.4, PC.8, PC.10) i.e. the meter shall calculate any charges pertaining to standing charges or other charges that may be recovered before updating the balance on the meter display.</p> <p>PC.11.7 The meter shall reject any remote top up Command where the revised balance would exceed the maximum allowable Meter Balance.</p> <p>PC.11.8 Remote top up Commands values shall be in £'s pence (€ cents)</p> <p>PC.11.9 The meter shall display the time and date that the Meter Balance was last updated.</p> <p>PC.11.10 The meter shall display the last 5 Meter Balance adjustments for the customer to view.</p> <p>PC.11.11 The Smart Metering System shall be configurable to respond to the top up command in the following ways:</p> <ul style="list-style-type: none"> • Send the acknowledgement of success or failure of the top up command • Send the acknowledgement of success or failure of the top up command and store a snapshot (see PC.7 for the data items captured as part of snapshot) in the meter memory. This shall be sent along with next scheduled meter read. • Take a snapshot and send along with the acknowledgement of the top up command to the supplier / DCC.' <p>PC.11.12 The meter log shall record and store the value of the credit, time and date it was added to the Meter Balance, the associated UTRN and any values allocated/deducted for debt repayments each time that a credit is applied. In addition, it will also log details of the method of application of the credit (remotely, locally). Note: UTRN shall not be deleted from the log.</p> <p>PC.11.13 The Smart Metering System shall log instances where remote top up Commands have not been processed within 48 hours and a rejection message has been sent to the supplier (e.g. no gas meter wake ups during this period).</p> <p>PC.11.14 The Smart Metering System shall be capable of holding a minimum of two unprocessed top up commands for each fuel type.</p> <p>PC.11.15 Where the meter has been locally disabled, the meter processes a top up Command, and this results in the meter becoming locally enabled the meter will provide a notification to advise the customer that the supply is available.</p> <p><u>gas meter Specific Issues</u></p> <p>PC.11.16 Whenever the smart gas meter wakes up, either as part of its wake up schedule or locally via button press, it shall check the SM HAN for any remote top up Commands to process.</p> <p>PC.11.17 Remote top up Commands sent to the gas meter shall be held by the Smart Metering System until such time as the gas meter wakes up, receives the Command and processes that Command.</p>
--	---

	<p>PC.11.18 The gas meter shall wake up and check for any remote top up Commands that are being held by the Smart Metering System for processing immediately prior to crossing its self disconnection/local disablement threshold.</p> <p>PC.11.19 In cases where an enhanced IHD is supplied to overcome inaccessibility issues, the Gas meter shall check for credit top ups at a more frequent and configurable period (xx minutes but no greater than 30 minutes.)</p> <p>PC.11.20 The wake up frequency as configured in PC11.19.1 shall revert back to the normal wake up period after a configurable timeout period (x hours.)</p> <p>PC.11.21 If the gas meter fails to pick up Commands during its wake up the Smart Metering System will hold the Commands to enable retries.</p> <p><u>Meter Balance Adjustments</u></p> <p>PC.11.22 The Smart Metering System shall be capable of accepting local (e.g. via an authorised HHT) or remote adjustments to the Meter Balance via authorised equipment.</p> <p>PC.11.23 The adjustment shall be either a positive or negative value.</p> <p>PC.11.24 If the meter is locally disabled as a result of insufficient credit and the credit adjustment takes the Meter Balance above the disablement threshold, the local restoration process will proceed as specified in ES.1, GS.5 & PC.3.</p> <p>PC.11.25 If the credit adjustment takes the credit balance below the disablement threshold, the meter shall be disabled in accordance with the requirements specified in PC.3.</p> <p>PC.11.26 Acknowledgements for balance adjustments will be processed in accordance with the requirements specified in 11.10.</p> <p>PC.11.27 The balance adjustment message should also contain a 'reason' message for customer display (e.g. "Supplier Adjustment" or an additional message to be displayed on the meter or IHD).</p>
Extended Narrative	<p>If a function is provided to locally wake up the gas meter consideration shall be given to the fact that this function could be abused to drain the gas meter battery.</p> <p>Safety Note: The requirements stated in PC.11.19 (1 and 2) do not imply acceptance that this function is acceptable as a safe operating procedure. It shall be recognized that the implied use of an IHD for inaccessible locations is subject to detailed and rigorous safety review.</p>
Justification	Consumer Groups
Domestic/Non-domestic	D/ND
Use Case(s)	UC 02.01 Manage PAYG add credit remotely v1. UC 02.05 Manage PAYG adjust balances v12
Normative Reference(s)	IEC 62056-61tbd
Data Item Reference(s)	<p>The following are the potential data items:</p> <p>Time</p> <p>Date</p> <p>UTRN</p> <p>Values £'s pence/€ cents?</p> <p>Input of UTRN – local or remote</p> <p>Configuration – sending of confirmation/rejection messages</p> <p>Meter snapshot – register reads, debt field values, Meter Balance (credit/debit)</p> <p>Debt adjust value -99999.99 ... +99999.99 GBP or €</p>

	Self Disconnected top-up Check Interval Integer minutes (default 20) Fast top-up Poll Timeout Integer hours (default 672) Event log item Fast top-up Elapsed + timestamp
Security Requirement(s)	Modification of the variables shall only be possible with the appropriate authorization, and the Security of encryption shall be handled as "Sensitive Events:" as defined by STEG.
Component(s) affected	All SMS components

Electricity Specific Requirements

1.101. The functional requirements associated with electricity include enablement/ disablement, registers for consumption and demand data, smart grids data and support for load control.

Prospectus Requirement	The Smart Metering System shall support safe remote and local enablement and disablement of supply into the consumer premises.
ID	ES.1
Extended Requirement	<p>ES.1.1 The Smart Metering System shall support:</p> <ul style="list-style-type: none"> • Remote arming • Remote disablement • Local arming • Local disablement • Remote restoration • Local restoration • Automatic Restoration of supply to consumer premises. <p>ES.1.2 The following requirements shall be configurable options within the final Smart Metering design.</p> <p>ES.1.3 An electricity meter shall be capable of remote disablement of the consumer's electricity supply and provide for the remote arming and remote restoration of the electricity supply through the use of a Load Switch.</p> <p>ES.1.4 A Load Switch shall be capable of responding to prepayment/PAYG commands. This functionality is described in requirement OP.8.</p> <p>ES.1.5 Where a consumer's electricity supply has been Disabled any faults within the meter shall not cause the supply to be armed or restored.</p> <p>ES.1.6 All of the meter's functionality (other than the flow of electricity to the premises) shall operate as normal, irrespective of whether the meter's Load Switch is open or closed.</p> <p>ES.1.5 Following Remote Disablement by an Authorised Party, the meter shall ensure that the supply can only be armed, or restored, by an instruction received from the same party (or one with the same authority). For example, where the supply is remotely disabled by a Supplier, it can only be armed by the same Supplier, subject to ES.1.6 below.</p> <p>ES.1.6 Where the meter has been Remotely Disabled by the Supplier the meter shall only be armed by a remote command issued by the current (or subsequent new) Supplier.</p> <p>ES.1.7 Where the meter has been armed, supply shall be Restored via a physical action requiring direct local action (e.g. by pressing a button).</p> <p>ES.1.8 Where the meter has been remotely disabled by a Network Operator a Remote Restoration command Restoration of the supply without the need for direct local action. Whilst disabled by a Network Operator, any command to change operation mode to credit shall not cause the meter to arm, or restore, supply.</p> <p>ES.1.9 The Load Switch shall be able to respond to commands initiated from a Network Operator initiated Load Limitation regime. See requirement ES.12.</p> <p>ES.1.10 The Load Switch shall be able to respond to commands initiated from a Supplier initiated Load Limitation regime. See requirement ES.12.</p> <p>ES 1.11 Under normal supply conditions, the six conditions shown in the diagram below are set at logic level 1 and the Load Switch is closed. Should one, or more, of the condition lines change to zero, the Load Switch opens. In the case of disablement due to Prepayment function, supplier's Remote Disablement command, Meter</p>

Integrity Sensor or Supplier initiated load limitation the supply will not be restorable until necessary arming and direct local action (e.g. button press) has taken place. In the case of a disablement due to Network Operator Remote Disablement or a Network Operator initiated load limitation requirement the supply shall be restored upon receipt of an appropriate restoration command from the Network Operator.

High level illustrative electricity SMS arming/disablement logic & gate diagram

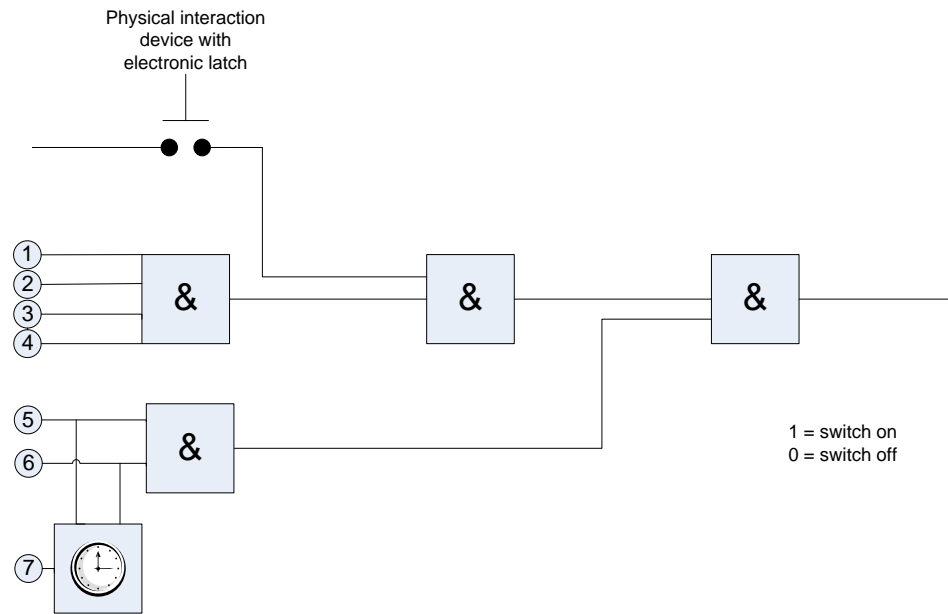

ES.1.12 All of the following conditions must be met (set at logic level1) for the supply to be restored:

1. Supplier remote setting condition met;
2. Prepayment condition met;
3. Meter integrity condition met; and
4. Load Limitation regime, set by supplier
5. Network Operator remote setting condition met.
6. Load Limitation regime, set by Network Operator
7. Automatic Restoration timeout routine

i.e. If any of the condition lines 1 to 4 should change to logic level zero then the Load Switch will open and also unlatch the physical interaction device. Restoration will require the condition line(s) in question to be reset to value “1” and the physical interaction device will need to be operated. Following Disablement when all four conditions are set back to logic level1 the physical interaction device will need to be operated in order to complete restoration.

ES.1.13 If condition lines 5 and/or 6 should change to logic level zero then the Load Switch will open. In this circumstance restoration will not require use of the physical interaction device. When the level on line 5/6 returns to logic level 1 the Load Switch will close as long as none of the condition lines 1-4 are at logic level 0. Lines 5 and 6 can also be reset to value logic level 1 by the Auto Restoration timer; this feature allows supply to be restored in the event of WAN failure. (See also Requirement ES.12)

ES.1.14 A meter operating in prepayment mode shall continue to collect non-energy related debt in the event of remote disablement.

ES.1.15 A meter operating in prepayment mode that has been remotely disabled by a Network Operator shall not react to any instruction from its prepayment processing to

	<p>switch off either during, or immediately (within [5] minutes) after, a period of disablement.</p> <p>ES.1.16 In the event that the supply is restored following disablement by a Network Operator, the meter shall not execute any command to disable for prepayment a minimum of [5] minutes after the restoration of supply, except where the meter is in a period of Friendly Credit, where it will not disable until the Friendly Credit period has expired.</p> <p>ES.1.17 Where a meter is operating in prepayment mode and a loss of supply has occurred for reasons outside of the control of the electricity meter (e.g. network power failure or removal of the service fuse), the Load Switch shall retain the operational status i.e. open or closed.</p> <p>ES.1.18 When the supply is re-instated if the switch is closed the meter shall not execute any command to disable for prepayment for a minimum of [5] minutes after the restoration of supply, except where the meter is in a period of Friendly Credit, where it will not disable until the Friendly Credit period has expired.</p> <p>ES.1.19 The meter Load Switch and associated circuitry shall be inaccessible to the consumer.</p> <p>ES.1.20 The Load Switch and associated operating mechanism shall be designed to operate reliably throughout the design life of the meter in accordance with Annex C.3 of IEC 62055-31 (a minimum of 10,000 operations).</p> <p>ES.1.21 Any detected failure of the Load Switch to operate on receipt of a valid instruction shall generate an alert that shall be immediately transmitted to DCC/Head end.</p> <p>ES.1.22 The metering system shall log the time/date and source of any changes to the status of the Local Switch.</p> <p>ES.1.23 Local restoration of supply shall be possible via an enhanced IHD over the SM HAN, or by means of any suitable approved device developed for this purpose.</p> <p>ES.1.24 A Load Switch shall not attempt to open if current in excess of its maximum rating is flowing.</p> <p>ES.1.25 A Load Switch shall be capable of closing on to short circuit, but this shall not give rise to a safety hazard (e.g. exposure of live conductors, fire, explosion, etc.).</p>
<p>Extended Narrative</p>	<p>Enablement and disablement actions are required functions for:</p> <ul style="list-style-type: none"> • Remote switching by Authorised Parties • Prepayment operations • Load limiting • Disablements triggered by safety alerts from sensors within the meter. <p>Safe remote and local enablement assumes that the restoration process requires local interaction with the consumer in some circumstances.</p> <p>As the requirements above are configurable, this allows for the design to incorporate possible future smart grid requirements. The default configuration of the Smart Meter design will be determined by governance discussions.</p>
<p>Justification</p>	<p>High-level list F and consumer safety.</p>
<p>Domestic/Non-domestic</p>	<p>D/ND</p>
<p>Use Case(s)</p>	<p>Relevant Use Cases are:</p> <p>UC 2 - Manage Prepayment UC 4 - Manage Events</p>

	UC 10 - Check Status and settings of Smart Metering system UC 11 - Enable supply UC 12 - Disable Supply UC 21 - Restart Supply UC 29 – Reconnect Supply
Normative Reference(s)	BS 7856 IEC 62055-31 IEC 62052-11 IEC 62053-21 EN60947-3 The Measuring Instruments (Active Electrical Energy Meters) Regulations SI 2006:1679 The Measuring Instruments (gas meters) Regulations 2006: 2647
Data Item Reference(s)	Data Items are: Load Switch status i.e. open / open and enabled / closed Disabled locally / remotely Disablement reason Credit Balance Emergency Credit Amount Threshold Type: <ul style="list-style-type: none"> • Reconnection threshold • Disconnection threshold Supply status
Security Requirement(s)	SP.1, SP.6, SP.7, SP.18, SP.19, SP.20, SP.21, SP.22, SP.23, SP.24
Component(s) affected	Electricity Meter

Prospectus Requirement	The Smart Metering System shall include at least one total register for cumulative import kWh.
ID	ES.2
Extended Requirement	ES.2.1 The Smart Metering System shall have at least one total register for cumulative import kWh for each element. ES.2.2 If there are additional registers to support tariff and business needs then these will be in addition to the total registers for cumulative import kWh. ES.2.3 The total register for cumulative import consumption shall not be capable of being reset. ES.2.4 In credit mode, the total register shall be the default register shown on the display; in prepayment mode, the requirements in DS.03 shall apply. ES.2.5 The format of the display of the register shall be five digits before the decimal point, and at least one digit after the decimal point. ES.2.6 The internal resolution of this half-hour data should be 0.001kWh. ES.2.7 This register shall not increment or decrement if export energy is flowing through the meter. For an electricity meter variant containing more than one measurement element: ES.2.8 The meter shall contain an independent register for cumulative Import kWh for each element

	<p>ES.2.9 Each independent element shall increment only if the associated switch is closed</p> <p>ES.2.10 There shall be clear indications of which measuring elements are in operation shall be displayed on the electricity meter display</p> <p>ES.2.11 Each independent measuring element shall meet all the requirements of ES.2 to ES.2.6.</p>
Extended Narrative	<p>For metering active energy flow into the premises. This is a MID requirement</p> <p>The tariffs associated with these requirements are given in PC.08</p>
Justification	High-level list A
Domestic/Non-domestic	D/ND
Use Case(s)	The UC.09 set
Normative Reference(s)	<p>Measuring Instruments Directive</p> <p>EN 50470-1</p> <p>WELMEC</p>
Data Item Reference(s)	<p>Measurement Quantity Description</p> <p>Measurement Quantity Id</p> <p>Meter Register Description</p> <p>Meter Register ID</p> <p>Meter Register Name</p> <p>Meter Register On Time</p> <p>Meter Register Off Time</p>
Security Requirement(s)	None
Component(s) affected	SMS Electric Meter

Prospectus Requirement	The Smart Metering System shall support at least one total register for cumulative export kWh
ID	ES.3
Extended Requirement	<p>ES.3.1 The Smart Metering System shall have at least one total register for cumulative export kWh for each element.</p> <p>ES.3.2 If additional registers are used to support tariff and business needs then these will be in addition to the total registers for cumulative export kWh.</p> <p>ES.3.3 The total register for cumulative export kWh shall not be capable of being reset locally or remotely.</p> <p>ES.3.4 This register shall be accessible via the meter's display.</p> <p>ES.3.5 The format of the display of the register shall be five digits before the decimal point and at least one digit after the decimal point.</p> <p>ES.3.6 The internal resolution of this half-hour data shall be 0.001kWh.</p> <p>ES.3.7 This register shall not increment or decrement if import energy is flowing through the meter element.</p>

	<p>ES.3.8 The export measurement will meet the equivalent performance requirements of MID import measurements.</p> <p>ES.3.9 For an electricity meter variant containing more than one measurement element:</p> <ul style="list-style-type: none"> • The meter shall contain an independent register for cumulative Export kWh for each element • Each independent element shall increment only if the associated switch is closed • A clear indication of which elements are in operation shall be displayed <p>ES.3.10 Each independent measurement element shall meet all the requirements of ES.3 to ES.3.6.</p>
Extended Narrative	<p>For metering active energy flow from the premises. This is a MID requirement</p> <p>The tariff requirements associated with the standard meter are given in PC.8.</p>
Justification	High-level list G
Domestic/Non-domestic	D/ND
Use Case(s)	UC.09
Normative Reference(s)	Measuring Instruments Directive WELMEC
Data Item Reference(s)	<p>Measurement Quantity Description</p> <p>Measurement Quantity Id</p> <p>Meter Register Description</p> <p>Meter Register ID</p> <p>Meter Register Name</p> <p>Meter Register On Time</p> <p>Meter Register Off Time</p>
Security Requirement(s)	None
Component(s) affected	SMS Electric Meter

Prospectus Requirement	The Smart Metering System shall support at least one total register for cumulative import kvarh
ID	ES.4
Extended Requirement	<p>ES.4.1 The Smart Metering System shall have at least one total register for cumulative import kvarh for each element.</p> <p>ES.4.2 The total register for cumulative import kvarh shall not be capable of being reset locally or remotely.</p> <p>ES.4.3 This register shall be accessible via the meter's display.</p> <p>ES.4.4 The format of the display of the register shall be five digits before the decimal point and at least one digit after the decimal point.</p> <p>ES.4.5 The internal resolution of this half-hour data should be 0.001kvarh.</p> <p>ES.4.6 This register shall not increment or decrement if export energy is flowing</p>

	<p>through the meter.</p> <p>ES.4.7 The meter shall not support any tariffs for reactive energy.</p> <p>For an electricity meter variant containing more than one measurement element:</p> <p>ES.4.8 The meter shall contain an independent register for cumulative Import kvarh for each element</p> <p>ES.4.9 Each independent element shall increment only if the associated switch is closed</p> <p>ES.4.10 A Clear indication of which measuring elements are in operation shall be displayed on the electricity meter</p> <p>ES.4.11 Each independent measuring element shall meet all the requirements of ES.4 to ES.4.6.</p>
Extended Narrative	<p>For metering reactive energy flow into the premises. This is a MID requirement</p> <p>The tariff requirements associated with the standard meter are given in PC.08</p>
Justification	Smart Grids
Domestic/Non-domestic	D/ND
Use Case(s)	The UC.09 set
Normative Reference(s)	EN 62053-23
Data Item Reference(s)	<p>Data Items:</p> <p>Measurement Quantity Description</p> <p>Measurement Quantity Id</p> <p>Meter Register Description</p> <p>Meter Register ID</p> <p>Meter Register Name</p> <p>Meter Register On Time</p> <p>Meter Register Off Time</p>
Security Requirement(s)	None
Component(s) affected	SMS Electric Meter

Prospectus Requirement	The Smart Metering System shall support at least one total register for cumulative export kvarh
ID	ES.5
Extended Requirement	<p>ES.5.1 The Smart Metering System shall have at least one total register for cumulative export kvarh for each element.</p> <p>ES.5.2 The total register for cumulative export kvarh shall not be capable of being reset either locally or remotely.</p> <p>ES.5.3 This register shall be accessible via the meter's display.</p> <p>ES.5.4 The format of the display of the register shall be five digits before the decimal place and at least one digit after the decimal place.</p> <p>ES.5.5 The internal resolution of this half-hour data shall be 0.001kvarh.</p>

	<p>ES.5.6 This register shall not increment or decrement if import energy is flowing through the meter element.</p> <p>ES.5.7 The meter shall not support any tariffs for reactive energy.</p> <p>ES.5.8 The export measurement shall meet the equivalent performance requirements of MID import measurements.</p> <p>For a Smart Electricity Meter variant containing more than one measurement element:</p> <p>ES.5.9 The meter shall contain an independent register for cumulative Export kvarh for each element</p> <p>ES.5.10 Each independent element shall increment only if the associated switch is closed</p> <p>ES.5.11 A clear indication of which elements are in operation shall be displayed</p> <p>ES.5.12 Each independent measurement element shall meet all the requirements of ES.5 to ES.5.7.</p>
Extended Narrative	For metering reactive energy flow from the premises. This is a MID requirement. The tariff requirements associated with the standard meter are given in PC.08
Justification	Smart Grids
Domestic/Non-domestic	D/ND
Use Case(s)	UC.09 set of Use Cases
Normative Reference(s)	EN 62053-23
Data Item Reference(s)	<p>Measurement Quantity Description</p> <p>Measurement Quantity Id</p> <p>Meter Register Description</p> <p>Meter Register ID</p> <p>Meter Register Name</p> <p>Meter Register On Time</p> <p>Meter Register Off Time</p>
Security Requirement(s)	None
Component(s) affected	Electricity Meter

Prospectus Requirement	The Smart Metering System shall support export kW measurement.
ID	ES.6
Extended Requirement	<p>ES.6.1 For a Base Smart Electricity Meter:</p> <p>ES.6.2 The meter shall store 13 months of half hour kW Import data.</p> <p>ES.6.3 Half hour data shall be stored as average Import kW.</p> <p>ES.6.4 The kW shall be recorded over each half-hour starting on the half-hour and the hour be identified by the time of the end of the Demand Period.</p> <p>ES.6.5 The half hour storage shall only be able to be reset locally or remotely by Authorised Parties and in accordance with the requirements of DS.06.</p>

	<p>ES.6.6 All registers with the exception of the total cumulative registers as defined in ES.2, ES.3, ES.4 & ES.5 can, if required, be reset at the same time.</p> <p>ES.6.7 The internal resolution of this half hour data should be 0.001kW.</p> <p>ES.6.8 Any residual fraction should be carried forward into the next period.</p> <p>ES.6.9 The kWh cumulative register will only increase while import energy is flowing through the meter.</p> <p>ES.6.10 Each half hour data set should have a status byte associated with it, which shall cover items that affect the values stored in the half hour such as change in the clock, power outage, reprogrammed, etc.</p> <p>ES.6.11 Only one status byte will be present regardless of the number of channels being stored.</p> <p>ES.6.12 For an electricity meter variant containing more than 1 measurement element:</p> <p>ES.6.13 The meter shall contain independent half hour data sets for each additional element.</p> <p>ES.6.14 Import may be on one or more or all elements.</p> <p>ES.6.15 Each independent measurement element shall meet all the requirements of ES.6.01 to ES.6.10.</p> <p>ES.6.16 The meter shall be able to store a minimum of 13 months of storage per data set.</p>
Extended Narrative	<p>A Base Smart Electricity Meter refers to one that conforms to the ESoDR Base Electricity requirements and has a single measurement element.</p> <p>The Data Storage requirements associated with the standard meter are given in DS.2. This requirement is supported by:</p> <ul style="list-style-type: none"> • Consumer groups • DNO, for understanding smart grid <p>Detail on the proposed Meter Variant solutions is given in the Electric Meter Variants paper.</p>
Justification	Smart grids
Domestic/Non-domestic	D/ND
Use Case(s)	US.09.
Normative Reference(s)	WELMEC 11.2 Issue 1
Data Item Reference(s)	<p>Measurement Quantity Description</p> <p>Measurement Quantity Id</p> <p>Meter Register Description</p> <p>Meter Register ID</p> <p>Meter Register Name</p> <p>Meter Register On Time</p> <p>Meter Register Off Time (this would be null in the case of a meter permanently recording consumption)</p>
Security Requirement(s)	None
Component(s) affected	Electricity Meter

Prospectus Requirement	The Smart Metering System shall support export kW measurement.
ID	ES.7
Extended Requirement	<p>ES.7.1 For a Base Smart Electricity Meter:</p> <p>ES.7.2 The meter shall store 3 months of half hour kW Export data.</p> <p>ES.7.3 Half hour data shall be stored as average Export kW.</p> <p>ES.7.4 The kW shall be recorded over each half-hour starting on the hour and half hour be identified by the time of the end of the Demand Period.</p> <p>ES.7.5 The half hour storage can only be deleted by Authorised Parties and in accordance with the requirements of DS.6.</p> <p>ES.7.6 All registers with the exception of the total cumulative registers as defined in ES.2, ES.3, ES.4 & ES.5 can, if required, be reset at the same time.</p> <p>ES.7.7 All registers with the exception of the total cumulative export kWh register defined in ES.03 can, if required, be reset at the same time.</p> <p>ES.7.8 Any residual fraction should be carried forward into the next period.</p> <p>ES.7.9 The total export cumulative register will only increase while export energy is flowing through the meter.</p> <p>ES.7.10 Each half hour data should have a status byte associated with it, which will cover items that affect the values stored in the half hour such as change in the clock, power outage.</p> <p>ES.7.11 Only one status byte will be present regardless of the number of channels being stored.</p> <p>ES.7.12 For a electricity meter variant containing more than one measurement element:</p> <p>ES.7.13 The meter shall contain independent half hour data sets for each additional element.</p> <p>ES.7.14 Export may be one or more or all elements through one or more elements.</p> <p>ES.7.15 Each independent measurement element shall meet all the requirements of ES.7.02 to ES.7.11.</p> <p>ES.7.16 Each element shall have a minimum 3 months of storage per data set.</p>
Extended Narrative	<p>ES.7 A Base Smart Electricity Meter refers to one that conforms to the ESoDR Base Electricity requirements and has a single measurement element.</p> <p>Details on the proposed Meter Variant solutions are given in the Electric Meter Variant Paper.</p>
Justification	Smart grids
Domestic/Non-domestic	D/ND
Use Case(s)	The UC.09 set.
Normative Reference(s)	WELMEC 11.2 Issue 1
Data Item Reference(s)	<p>Measurement Quantity Description</p> <p>Measurement Quantity Id</p> <p>Meter Register Description</p> <p>Meter Register ID</p> <p>Meter Register Name</p> <p>Meter Register On Time</p> <p>Meter Register Off Time (this would be null in the case of a meter permanently recording consumption)</p>
Security	None

Requirement(s)	
Component(s) affected	Electricity Meter

Prospectus Requirement	The Smart Metering System shall support import kVAr measurement.
ID	ES.8
Extended Requirement	<p>ES.8.1 For a Base Smart Electricity Meter:</p> <p>ES.8.2 The meter shall store three months of half hour kVAr Import data.</p> <p>ES.8.3 Half hour data shall be stored as Import kVAr.</p> <p>ES.8.4 The kVAr shall be recorded over each half-hour starting on the half-hour and the hour be identified by the time of the end of the Demand Period.</p> <p>ES.8.5 The half hour data storage can only be reset locally or remotely by Authorised Parties and in accordance with the requirements of DS.6.</p> <p>ES.8.6 All registers with the exception of the total cumulative registers as defined in ES.2, ES.3, ES.4 & ES.5 can, if required, be reset at the same time.</p> <p>ES.8.7 The internal resolution of this half hour data shall be 0.001kvar.</p> <p>ES.8.8 Any residual fraction shall be carried forward into the next period.</p> <p>ES.8.9 This register shall only increase while import energy is flowing through the meter.</p> <p>ES.8.10 Each half hour data set shall have a status associated with it, this shall cover items that affect the values stored in the half hour such as change in the clock, power outage.</p> <p>ES.8.11 Only one status shall be present regardless of the number of channels being stored.</p> <p>ES.8.12 For an electricity meter variant containing more than one measurement element:</p> <p>ES.8.13 The meter shall contain independent half hour data sets for each additional element.</p> <p>ES.8.14 Import may be on one or more or all elements.</p> <p>ES.8.15 Each independent measurement element shall meet all the requirements of ES.8 to ES.8.10</p> <p>ES.8.16 There shall be a minimum of three months of storage per data set.</p>
Extended Narrative	<p>ES.8.1 A Base Smart Electricity Meter refers to one that conforms to the ESoDR Base Electricity requirements and has a single measurement element.</p> <p>ES.8.2 The Data Storage requirements associated with the standard meter are given in DS.2. This requirement is supported by:</p> <ul style="list-style-type: none"> • Consumer groups • DNO, for understanding smart grid. <p>Detail on the proposed Meter Variant solutions is given in the Electricity Meter Variants paper.</p> <p>ES.8.12 The Data Storage requirements associated with the standard meter are given in DS.2 – for a single element, however this shall be also applicable to the second element. This requirement is supported by:</p> <ul style="list-style-type: none"> • Consumer groups

	<ul style="list-style-type: none"> DNO, for understanding smart grid.
Justification	Smart grids
Domestic/Non-domestic	D/ND
Use Case(s)	US.09 set of Use Cases.
Normative Reference(s)	WELMEC 11.2 Issue 1 EN 62053-23
Data Item Reference(s)	Measurement Quantity Description Measurement Quantity Id Meter Register Description Meter Register ID Meter Register Name Meter Register On Time Meter Register Off Time (this would be null in the case of a meter permanently recording consumption)
Security Requirement(s)	None
Component(s) affected	Electricity Meter

Prospectus Requirement	The Smart Metering System shall support export kVAr measurement.
ID	ES.9
Extended Requirement	<p>ES.9 For a Base Smart Electricity Meter:</p> <p>ES.9.1 The meter shall store 3 months of half hour kVAr Export data.</p> <p>ES.9.2 Half hour data shall be stored as Export kVAr.</p> <p>ES.9.3 The kVAr shall be recorded over each half-hour starting on the hour and half-hour identified by the time of the end of the Demand Period.</p> <p>ES.9.4 The half hour storage can only be reset by Authorised Parties and in accordance with the requirements of DS.6.</p> <p>ES.9.5 All registers with the exception of the total cumulative registers as defined in ES.2, ES.3, ES.4 & ES.5 can, if required, be reset at the same time.</p> <p>ES.9.6 The internal resolution of this half hour data shall be 0.001kvar.</p> <p>ES.9.7 Any residual fraction shall be carried forward into the next period.</p> <p>ES.9.8 This register shall increase while export energy is flowing through the meter.</p> <p>ES.9.9 Each half hour data set shall have a status associated with it, this shall cover items that affect the value of stored in the half hour such as change in the clock, power outage – the status byte could be in line with the current code of practice.</p> <p>ES.9.10 Only one status byte shall be present regardless of the number of channels being stored.</p> <p>For an electricity meter variant containing more than 1 measurement element:</p> <p>ES.9.11 The meter shall contain independent half hour data sets for each additional element.</p> <p>ES.9.12 Export may be on one or more or all elements if generation is on site and customer wants to export it.</p> <p>ES.9.13 Each independent measurement element shall meet all the requirements of ES.9 to ES.9.10</p> <p>ES.9.14 There shall be a minimum 3 months of storage per data set.</p>

Extended Narrative	<p>ES.9 A Base Smart Electricity Meter refers to one that conforms to the ESoDR Base Electricity requirements and has a single measurement element.</p> <p>ES.9.01 The Data Storage requirements associated with the standard meter are given in DS.2. This requirement is supported by:</p> <ul style="list-style-type: none"> • Consumer groups • DNO, for understanding smart grid. <p>Detail on the proposed Meter Variant solutions is given in the Electricity Meter Variants paper.</p>
Justification	Smart grids
Domestic/Non-domestic	D/ND
Use Case(s)	UC.09.
Normative Reference(s)	WELMEC 11.2 Issue 1 EN 62053-23
Data Item Reference(s)	<p>Measurement Quantity Description</p> <p>Measurement Quantity Id</p> <p>Meter Register Description</p> <p>Meter Register ID</p> <p>Meter Register Name</p> <p>Meter Register On Time</p> <p>Meter Register Off Time (this would be null in the case of a meter permanently recording consumption).</p>
Security Requirement(s)	None
Component(s) affected	Electricity Meter

Prospectus Requirement	The Smart Metering System shall support measurement of other power quality data including RMS voltage, over/under voltage, sag/swell.
ID	ES.10
Extended Requirement	<p>ES.10 The Smart Metering System shall support measurement of power quality data, including RMS (Root Mean Square) voltage, over/under voltage, sag/swell.</p> <p>ES.10.1 The electricity meter shall be capable of measuring RMS voltages averaged over a configurable period (typically 30 minutes, but configurable to 10 minutes to align with BS EN50160), and such measurements shall be stored with a date and time stamp.</p> <p>ES.10.2 The electricity meter shall calculate the RMS voltage in accordance with BS EN 61000-4-30 (2009) Testing and measurement techniques — Power quality measurement methods. The sample rate is to be in accordance with Section 5.2.1 Class B, with a sampling rate not less than once per second. The voltage shall be measured with a minimum accuracy of +/-1%.</p> <p>ES.10.3 The electricity meter shall be capable of storing three months of RMS voltages (averaged over a 30-minute period). It is recognised that the period of time to which the data relates will be reduced correspondingly if 10-minute averages are</p>

stored (e.g. from three months to one month).

ES.10.4 The electricity meter shall be capable of being configured to identify when under-voltage and over-voltage events have occurred. The event thresholds shall be configurable in terms of the period of time the voltage is less than / exceeds a defined threshold voltage. Two under voltage and two over voltage event thresholds should be configurable. The response to the event, e.g. initiate an alarm or open the Load Switch, shall be configurable. Any configuration shall be within the capability of the meter. A summary of this information is included in the DI.1 requirement and its associated Appendix.

Under / over voltage event definition:

- The event occurs when the:
 - 30-minute mean RMS voltage falls below the under voltage threshold (XX Volts) for YY half hourly periods in a defined period (ZZ days)
 - 30-minute mean RMS voltage exceeds the over voltage threshold (XX Volts) for YY half hourly periods in a defined period (ZZ days).
- where:
 - (XX) range 180 - 300V
 - (YY) range 1 – 50
 - (ZZ) range 1 – 30 days.

Extreme under / over voltage event definition:

- The event occurs when the:
 - RMS voltage falls below the under voltage threshold (XX Volts) but exceeds a lower voltage threshold of (X'X' Volts) for ZZ seconds³
 - RMS voltage exceeds the over voltage threshold (XX Volts) for ZZ seconds.
- where:
 - (XX) range 180 – 440V
 - (ZZ) range 1 – 300 seconds.

ES10.5 The electricity meter shall be capable of capturing the minimum / maximum RMS voltage associated with each under and over-voltage event for inclusion in the event / alarm log.

ES.10.6 The electricity meter shall be capable of capturing the minimum / maximum voltage associated with a defined period of time. A summary of this information is included in the DI.1 and its associated Appendix.

Min / Max Voltage definition:

- The lowest mean RMS voltage (XX Volts) (but exceeding a configurable minimum voltage threshold (X'X' Volts)) in a configurable period (ZZ)
- The highest mean RMS voltage (XX Volts) in a configurable period (ZZ).

³ Two thresholds are required to ensure that the load switch is not opened in the event of a loss of supply.

	<ul style="list-style-type: none"> • where: • (XX) range 180 – 300V • (ZZ) range 1 – 90 days. <p>ES.10.7 The electricity meter, including each phase of polyphase meters, shall follow the requirements set out in DI.1, DI.02, DI.03, ES.01, and ES.12.</p> <p>ES.10.8 All voltage readings measured / recorded shall be absolute values and not a percentage of a nominal voltage.</p> <p>ES.10.9 The electricity meter shall be capable of being configured to identify when voltage sag / swell events have occurred. The event thresholds shall be configurable in terms of when the voltage is less than / exceeds a defined threshold voltage for a configurable period of time. The response to the event e.g. to initiate an alarm, shall be configurable. A summary of this information is included in the DI.1 and its associated Appendix.</p> <p><u>Voltage sag / swell alarm event definition:</u></p> <ul style="list-style-type: none"> • The event occurs when the: • RMS voltage exceeds a high voltage threshold (XX Volts) for ZZ seconds • RMS voltage exceeds the low voltage threshold (XX Volts) for ZZ seconds. • where: • (XX) range 180 - 300V • (ZZ) range 1 – 300 seconds. <p>ES.10.10 Polyphase meters shall meet the functional requirements of ES.10 for each individual phase metered.</p> <p>ES.10.11 The specific phase applicable to data / alarms will be identifiable.</p>
Extended Narrative	Network requirement, RMS voltage may have to be stored for three months at half-hourly intervals. Accuracy preference from the DNOs is for +/-0.5%.
Justification	Smart Grids
Domestic/Non-domestic	D/ND
Use Case(s)	<p>The requirement is largely non functional but implied Use Cases are:</p> <p>UC 04 Manage Events – Set Event Parameters and Rules</p> <p>UC 04.02 Manage Events - Respond to event</p> <p>UC 05 – Manage Parameters and Configuration</p> <p>UC 09 – Read Meter series.</p>
Normative Reference(s)	<p>BS EN50160</p> <p>BS EN 61000-4-30 (2009) Testing and measurement techniques</p> <p>WELMEC 11.2 Issue 1</p>
Data Item Reference(s)	<p>Data Items are:</p> <p>Measurement Quantity Description</p> <p>Measurement Quantity ID</p> <p>Meter Register Description</p>

	Meter Register ID Meter Register Name Meter Register On Time Meter Register Off Time (This would be null in the case of a meter permanently recording consumption)
Security Requirement(s)	SP.22, SP.24 and SP.26
Component(s) affected	Electricity Meter

Prospectus Requirement	The Smart Metering System shall support capture of consumption and demand data at 5 second intervals.
ID	ES.11
Extended Requirement	ES.11.1 The Electricity Meter shall support capture of consumption and demand data at 5 second intervals for transmission via the SM HAN.
Extended Narrative	Supports the requirement for real time information on an IHD via the SM HAN – HA.3 refers. This function is to capture consumption data in short bursts to assist in the analysis of usage of consumer equipment (both domestic and non-domestic) to support energy efficiency and network analysis. The requesting device will limit requests to be no more frequent than five seconds. It is not necessary for the meters to store the five-second interval data.
Justification	High-level list C
Domestic/Non-domestic	D/ND
Use Case(s)	UC 19.01
Normative Reference(s)	N/A
Data Item Reference(s)	The register structures on the data model will support this, although this requirement is primarily concerned with a physical requirement relating to frequency of measurement and communication of data. The requirement for limiting IHD requests to no more frequent than five seconds could be supported by the following data item: Last Communication DateTime
Security Requirement(s)	N/A
Component(s) affected	Electricity Meter, IHD, Communications Hub

Prospectus	The Smart Metering System shall allow the supply switch to be configurable to be
------------	--

Requirement	open or closed for a range of events.
ID	ES.12
Extended Requirement	<p>ES.12.1 The Smart Metering System shall allow the Load Switch to be configured to open for a range of operational events including:</p> <ul style="list-style-type: none"> • Breach of Load Limiting threshold • Activation due to a Meter Integrity Sensor • Exhausting credit in Prepayment/PAYG • Remote Command from Supplier or DNO <p>ES.12.2 The Smart Metering System shall allow the Load Switch to be configurable to be open, armed or closed for a range of operational events as follows:</p> <ul style="list-style-type: none"> • Remote Command as detailed in ES.1 • Local Command as detailed in ES.1/OP.8 <p>ES.12.3 Where the supply has been disabled as a result of an Energy Consumption Threshold being exceeded, the meter shall be configurable to either be armed, or restored, at the end of the period to which the Energy Consumption Threshold applies (e.g. immediately before the start of the next half hourly period). (See ES.1 for applicable logic).</p> <p>ES.12.4 Where the supply has been disabled as a result of a Maximum Demand Threshold being exceeded, the meter shall be configurable to either be immediately armed, or restored after a configurable time period. (See ES.1 for applicable logic.)</p> <p>ES.12.5 Where the supply has been disabled due to a Meter Integrity Alert the supply can only be armed and restored during a site visit by an engineer working on behalf of a Supplier.</p> <p>ES.12.6 Where the supply has been disabled as a result of pre-payment function, local restoration is possible as detailed in OP.8/ES.1</p>
Extended Narrative	<p>Other requirements will need to be in place to detect the originating conditions; this requirement covers a particular action in relation to their presence.</p> <p>Important Note: There is a need for governance to be agreed and established between stakeholders on the values of these thresholds, limits and configurations. This governance is beyond the scope of this document.</p> <p>The switch logic related to the above functions is described in ES.1.</p> <p>It should be noted that there is currently consideration being given to the switch opening in the event that voltage goes out of normal range. A decision will be made following a safety risk assessment.</p>
Justification	High-level list F
Domestic/Non-domestic	D/ND
Use Case(s)	<p>UC 02.08 Manage PAYG - Self-disconnect Supply</p> <p>UC 11.01 Enable supply</p> <p>UC 12.01 Disable supply</p> <p>The UC 16 set - manage load</p> <p>UC29.01 Reconnect supply</p>
Normative Reference(s)	EN 62055-31, EN 62052-11, EN 62053-21, EN 62054-21, EN 60947-3
Data Item Reference(s)	<p>Thresholds and Triggers</p> <p>Severity</p>

	Threshold High Limit Threshold Low Limit Threshold Type Action ID Action Type Instruction on Action Action Description
Security Requirement(s)	SP.1, SP.6, SP.7, SP.10, SP.18, SP.19, SP.20, SP.21, SP.22, SP.23, SP.24, SP.26
Component(s) affected	Electricity meter

Prospectus Requirement	The Smart Metering System shall support auxiliary switching and load control commands from remote Authorised Parties.
ID	ES.13
Extended Requirement	<p>ES.13.1 The Smart Metering System shall be capable of supporting auxiliary switching and load control commands from Authorised Parties.</p> <p>ES.13.2 The Smart Metering System shall be capable of implementing load management commands on receipt.</p> <p>ES.13.3 The Smart Metering System shall be capable of operating switches external to the Electricity Meter via devices that are 'paired' to the SM HAN in accordance with defined rules.</p> <p>ES.13.4 The Smart Metering System shall be capable of providing load management signals to devices 'paired' to the SM HAN in accordance with defined rules.</p> <p>ES.13.5 The Smart Metering System shall be capable of operating the Load Switch to disable all supplies to the consumer in accordance with defined rules.</p> <p>ES.13.6 The Smart Metering System shall be capable of implementing switching in accordance with defined switching schedules.</p> <p>ES.13.7 The Smart Metering System shall be configurable to be able to randomise scheduled switching instructions. Randomisation of Load Switching shall be controlled through a random number, a scalar and an enable/disable randomised switching data item, controlled by Authorised Parties. The same randomisation shall apply to the operation of the auxiliary switch and change of the corresponding rate register at the start of the scheduled period. The operation of the auxiliary switch and change of the corresponding rate register at the end of the period shall be at a defined period of time after the start of the scheduled period. This shall allow, for example, a customer to benefit from 7 hours at the off-peak rate under an Economy 7 tariff.</p> <p>ES.13.8 In the event of an interruption to a consumer's local load management facility (Boost facility) due to a supply interruption, upon supply restoration the consumer's local load management facility shall recommence its operation and complete its cycle.</p> <p>ES.13.9 Requirements ES.13.10 and ES.13.11 shall apply to meter variants only.</p> <p>ES.13.10 The Smart Metering System shall be capable of operating auxiliary switches internal to the Electricity Meter in accordance with defined rules. The internal auxiliary switches should generally operate in accordance with the same rules governing the operation of the main isolation switch as well as to any additional rules.</p> <p>ES.13.11 The Smart Metering System shall be capable of operating switches external to the Electricity Meter via a hardwired connection in accordance with defined rules.</p> <p>ES.13.12 The Smart Metering System shall be capable of controlling load in</p>

	<p>alignment with a threshold being reached (for example via a pre-payment Meter).</p>
<p>Extended Narrative</p>	<p>This requirement may be achieved through a variety of means including:</p> <ul style="list-style-type: none"> • Auxiliary switches internal to the meter used to control off-peak loads directly or via hardwired “simple” external contactors • SM HAN-controlled contactors controlling customers load circuits (e.g. off-peak heating, water heating, and electric vehicle charging circuits). SM HAN-controlled contactors could be controlled by the meter, or addressed directly by an Authorised Party. • Customer appliances with “intelligence” to respond to load control messages via the SM HAN and gateway • Operation of the main electricity meter isolator if the current exceeds pre-agreed limits or if other business rules are met. <p>Over time it is expected, especially for new installations, that SM HAN-based solutions using a base specification meter will be deployed rather than solutions requiring a meter variant.</p> <p>ES.13.5 anticipates load-controlling auxiliary switches to be connected in parallel to the main switch, and therefore any rules applicable to the main switch (e.g. prepay, disable, enable, load limiting as defined in ES.12) should also apply to the auxiliary switches, as well as any additional rules such as time-of-day operation.</p> <p>ES.13.10 is to permit meter variants to have (small) auxiliary relays to control external switches for load control. These relays do not need to operate main switch defined rules (e.g. prepay, disable, enable) as the load will be controlled by the main switch as well as the external switches.</p> <p>Note: The time at which Load Switching is scheduled to occur should be randomly staggered from the nominal scheduled switching time, in order to reduce voltage step changes, which would cause flicker, and reduce the Quality of Supply to customers. Where the switching is on a rate change boundary, the rate registers should also be staggered in changing to ensure the customer’s managed load is charged at the correct rate. The same stagger shall apply to the beginning and end of the load period, so the customer is still provided with the agreed period (e.g. 7 hours of heating charge for Economy 7 and at the low rate).</p> <p>Existing metering provides stagger through a variety of means; accuracy of setting, clock drift, and deliberate stagger in software-controlled devices. The RTS system provides up to +/- 3.5 minutes stagger where time setting is to the nearest 7.5 minute boundary, offering a continuous spread of randomised load.</p> <p>The proposal is that Smart Metering randomisation shall be configurable up to +/- 15 minutes.</p> <p>Note: this is a maximum, and Authorised Parties can reduce the degree of randomisation, by adjusting the scalar value (Random number x scalar = offset or stagger time in seconds).</p> <p>Note: These requirements enable the legacy industry supported load control</p>

	<p>functionality to be provisioned within the SMS.</p> <p>Note: Re: ES.13.02; in the event of a supply interruption that interrupts a consumer's boost period, upon supply restoration the consumer's load control equipment (i.e. Water Heating Boost Facility) re-enables to complete the remaining time of the boost period.</p>
Justification	High-level list E
Domestic/Non-domestic	D/ND
Use Case(s)	BS60947-3 Low Voltage Switch Gear and Control Gear. BSEN 62054-21 Electricity metering equipment (a.c.). Tariff and load control. BS7951 Specification for Electricity Meters - Alternating-Current Single-Phase Static Watt-Hour Telemeters of Accuracy Class 1 or 2.
Normative Reference(s)	EN50470-3 EN62055-31
Data Item Reference(s)	<p>Data Items:</p> <p>Random Offset Random Offset Enabled Random Offset Scalar Supply Status DateTime Cancelled DateTime Created Effective From Date/Time Effective To Date/Time Element 1 Immediate Rate Element 2 Immediate Rate Element Register Identifier Group Code Switch Number Switch On Status Switch Type Switching Period Id Switching Period Off Switching Period On Variant Reference</p>
Security Requirement(s)	SP.6, SP.18, SP.19, SP.20, SP.21
Component(s) affected	SMS Electricity Meter (Base & Variants)

Gas Specific Requirements

1.102. The functional requirements associated with gas include enablement/ disablement, registers for consumption data and local storage of calibration data (defined here as calorific value and other conversion factors). Other requirements include how frequently gas data is transmitted, recognising that battery life for gas meters can be an issue.

Prospectus Requirement	The Smart Metering System shall support local storage of energy calculation data (calorific value and PTZ conversion factor).
ID	GS.1
Extended Requirement	GS.1 The Smart Metering System shall support local storage of energy calculation data (Calorific Value and PTZ Conversion factor). GS.1.1 The Smart Metering System shall be capable of remote configuration of its energy calculation data.
Extended Narrative	<p>This requirement provides for a unique and unambiguous identifier for each of the components of the Energy Calculation Data which will facilitate easy interpretation by the Smart Metering System.</p> <p>The Energy Calculation Date relates to Calorific Values and PTZ Conversion Factor. The data communication from the DCC must include:</p> <ul style="list-style-type: none"> • Unique identifier for each data item • Value • Effective from date. <p>The format and structure of the above data items will be as defined in the data catalogue.</p> <p>Calorific Value needs to be capable of values from 000.0 to 999.9. The typical UK range for natural gas is around 36 to 42. However, there are some Propane networks where the CV can be around 90, and therefore it is prudent to hold the third digit. Note that while city gas should fall within this range, as it has a CV lower than natural gas, other fuel gases have not been considered.</p> <p>If PTZ is a single factor, then it shall be capable of values from 0.00000 to 9.99999. The UK G(COTE)R defines the value for domestic meters as 1.02264.</p> <p>Note: Should there be consideration of temperature compensated values then the issues below will need consideration.</p> <p>In theory, a meter (especially for SME) could have the technology to measure temperature (and pressure) directly. In this case, the factor as 1.02264 is inappropriate, and a factor of 1.01272 is probably applicable. However, in this situation, the base temperature for calculation needs to be supplied to the meter – currently 288.15K. If pressure and temperature are measured locally, then the factor should be set to 1.00000, but a further factor for base pressure needs to be supplied to the meter – currently 1013.25 mbar.</p> <p>The Calorific Value will not be applied retrospectively or pre-emptively. (This</p>

	includes prepayment.) The m ³ to kWh conversion should be done on the gas meter and should be made available for other SMS components.
Justification	High-level list A
Domestic/Non-domestic	D/ND
Use Case(s)	UC 5.01 Manage Parameters and Configuration
Normative Reference(s)	EN 12405-1:2005
Data Item Reference(s)	IHD Data and Meter Configuration Data, In particular, Calorific Value Calorific Value Effective From Date PTZ Conversion Factor PTZ Effective From date
Security Requirement(s)	N/A
Component(s) affected	gas meter, Communications Hub

Prospectus Requirement	The Smart Metering System shall support at least one total register for gas consumption.
ID	GS.2
Extended Requirement	GS.2.1 The gas meter shall have one total register for Import gas consumption in m ³ . GS.2.2 The total register for gas consumption shall not be capable of being reset either locally or remotely. GS.2.3 The meter, when operating in credit mode, shall have its total register on the default display and shall meet the requirements of DS.9. GS.2.4 The accuracy of the measurement, clarity and function of the display shall be in accordance with relevant statutory instruments. GS.2.5 The format of the display of the register shall be five digits before the decimal point, and three digits after the decimal point.
Extended Narrative	All GB suppliers currently operating in the licensed market use only meters registering in volume.
Justification	High-level list A
Domestic/Non-domestic	D/ND
Use Case(s)	Non Functional – UC_09 implied
Normative Reference(s)	Measuring instruments Directive, EN1359, EN14236, EN12480

Data Item Reference(s)	Meter Configuration Data, in particular: Measurement Quantity Description Measurement Quantity Id Meter Register Description Meter Register ID Meter Register Name Meter Register On Time Meter Register Off Time (this would be null in the case of a meter permanently recording consumption).
Security Requirement(s)	N/A
Component(s) affected	gas meter

Prospectus Requirement	The Smart Metering System shall support at least 48 wake up events per 24-hour period.
ID	GS.3
Extended Requirement	<p>GS.3.1 Every half-hour, on the half-hour, (i.e. at minute 00 and minute 30) the gas meter shall:</p> <ul style="list-style-type: none"> • Record 30-minute interval consumption data in non-volatile memory • If there has been gas consumption or relevant activity since the last communication to the Communications Hub: • Activate the communications device • Send all relevant information since the last successful communication, including 'empty intervals' to the Communications Hub • Allow incoming instructions for the meter to be received. • When these actions have been completed, or where no gas consumption has occurred, return to 'dormant' mode <p>GS.3.2 The gas meter shall communicate with the Communications Hub at least once a day, even if this is just to:</p> <ul style="list-style-type: none"> • Send interval data with no consumption registered • Allow incoming instructions for the meter to be received. <p>GS.3.3 Gas meters shall include a means to initiate an immediate "wake up" and/or "wake up" at a pre-determined time. Examples of such a means include, but are not limited to:</p> <ul style="list-style-type: none"> • Provision to accept a command, during a normal data transfer (typically a daily update of meter reading), to enable it to wake up at a specific time when it may receive further instructions; • The ability of a button push or series of button pushes on the meter to instigate an immediate wake up. • Operation of the Valve.
Extended Narrative	For battery life reasons the gas meter cannot be in permanent listening mode. It will wake up at predetermined times to send/receive data and commands. Where there has been no gas consumption or relevant activity, it is not necessary for the gas meter to

	communicate with the communications Hub.
Justification	High-level list A
Domestic/Non-domestic	D/ND
Use Case(s)	N/A
Normative Reference(s)	WELMEC 11.2 Issue 1
Data Item Reference(s)	The register structures on the data model will support this, although this requirement is primarily concerned with a physical requirement relating to frequency of measurement and communication of data.
Security Requirement(s)	N/A
Component(s) affected	gas meter

Prospectus Requirement	The Smart Metering System shall support capture of gas consumption data at 6 minute intervals.
ID	GS.4
Extended Requirement	<p>The Smart Metering System shall support capture of gas consumption data at six-minute intervals.</p> <p>GS.4.1 The gas meter shall be capable of responding to a local, or remote, command to initiate a 'fast' sampling of the gas index at six-minute intervals for a defined period of at least 1 hour, and not more than 24 hours.</p> <p>GS.4.2 The Smart Metering System shall be capable of responding to a local, or remote, command to make the stored data available.</p> <p>GS.4.3 The data shall be available locally over the SM HAN and remotely to the DCC/Headend</p> <p>GS 4.4 The Smart Metering System shall record details in the relevant logs when it is put into, 'fast sampling' mode, and where the request to take these actions originated.</p>
Extended Narrative	<p>This functionality is expected to be used on a very small minority of meters within specific geographies to assist with short-term local diagnostics, particularly for network operators. For domestic customers, it is anticipated that the fast sample would be set for a 4 hour period to cover peak gas use, with the 24 hour sampling being restricted to non-domestic customers.</p> <p>The potential impact on battery life is recognised to be an issue and the requirement does not imply that data has to be routinely transmitted at this increased frequency. If data is not immediately transmitted it must be stored.</p> <p>The storage of 'fast sampled' gas data should be subject to the same 'First In First Out' memory capacity management rules as other dynamic data items.</p>
Justification	High-level list C
Domestic/Non-domestic	D/ND

Use Case(s)	UC 09.02 Read Meter – Historical Reads UC 09.03 Read Meter – Schedule Ad Hoc Readings UC 09.04 Read Meter – Schedule and Capture Regular Readings
Normative Reference(s)	N/A
Data Item Reference(s)	The register structures on the data model will support this, although we are primarily talking about a physical requirement relating to measurement and communication of data. Data Items: Meter Register ID Register Reading Reading Date & Time.
Security Requirement(s)	Access to the event log shall be possible only with the appropriate authorisation
Component(s) affected	gas meter, Communications Hub

Prospectus Requirement	The Smart Metering System shall support a Valve for enablement and disablement of gas supply.
ID	GS.5
Extended Requirement	<p>GS.5 The Smart Metering System shall support a Valve for safe enablement and disablement of gas supply into the consumer premises. It shall be possible to enable or disable the Valve either remotely or locally.</p> <p>GS.5.1 The Valve shall be capable of receiving a local or remote commands.</p> <p>GS.5.2 The Valve shall operate correctly under the approved pressure range over the MID-approved Temperature range for the meter.</p> <p>GS.5.3 The Valve shall operate at a maximum pressure of 75mB and shall not pass more than 5dm³ of gas per hour when closed as per prEN16314 – draft standard for Gas Additional Functionalities).</p> <p>GS.5.4 The Valve shall have a demonstrable safe-to-open strategy so that the failure of any single component will not inadvertently operate the Valve</p> <p>GS.5.5 The circuitry associated with the Valve shall be inaccessible to the consumer.</p> <p>GS.5.6 The state of the Valve (open or closed) shall be displayed to the consumer.</p> <p>GS.5.7 Any failure of the Valve to operate on receipt of a valid instruction shall generate an alert event that shall be transmitted to Authorised Parties.</p> <p>GS.5.8 The Valve shall be leak tested in accordance with section 8.14.6.3.1 of prEN16314.</p> <p>GS.5.9 The Valve shall perform correctly following the Toluene/Iso-Octane vapour test specified in section 8.14.7 of prEN16314</p> <p>GS.5.10 The Valve shall withstand a dust test as specified in section 5.4 of prEN16314.</p> <p>GS.5.11 The minimum operating and storage temperature range shall be – at least -10 °C to +40 °C.</p> <p>GS.5.12 The Valve shall have a durability in excess of 4000 cycles, as specified in section 8.14.9.1. of prEN16314.</p> <p>GS.5.13 The Valve shall be able to change state reliably throughout the design life of</p>

the meter.

GS.5.14 The Valve shall be capable of changing state after long periods of inactivity.

GS.5.15 The gas meter shall maintain a count of Valve operations.

GS.5.16 The metering system shall record the time/date and source of any changes to the status of the Valve, and whether the status change was initiated locally or remotely, in accordance with DI.1.

GS.5.17 For Valve operational safety mechanisms, see GS.10.

GS.5.18 Where a consumer's gas supply has been disabled, any faults within the Meter shall not cause the supply to be enabled or restored.

GS.5.19 A Valve shall be capable of responding to prepayment commands. This functionality is described in OP.8.

GS.5.20 All of the gas meter's functionality (other than the allowance of gas to pass) shall operate as normal, irrespective of whether the Valve is open or closed.

GS.5.21 Following remote disablement by an Authorised Party, the meter can be armed only by an instruction received from the same Authorised Party, e.g. where the supply is remotely disabled by a Supplier it can be armed only by the same Supplier. In the case of a Change of Supply, the new Supplier shall be able to arm the meter once they become the active Supplier. In all remote disablement scenarios, remote re-arming followed by physical interaction at the meter is required to restore gas flow. The physical interaction shall take the form of an action requiring direct operation (e.g. pressing a button) within the relevant premises to restore gas flow.

GS.5.22 The gas meter Valve shall re-enable only if three conditions related to enablement are set at logic level 1. Should any one or more of the condition lines fall to zero, the Valve will close and will not be restorable until necessary re-enablement activity has taken place, (see logic diagram below.):

Gas Valve operation logic model

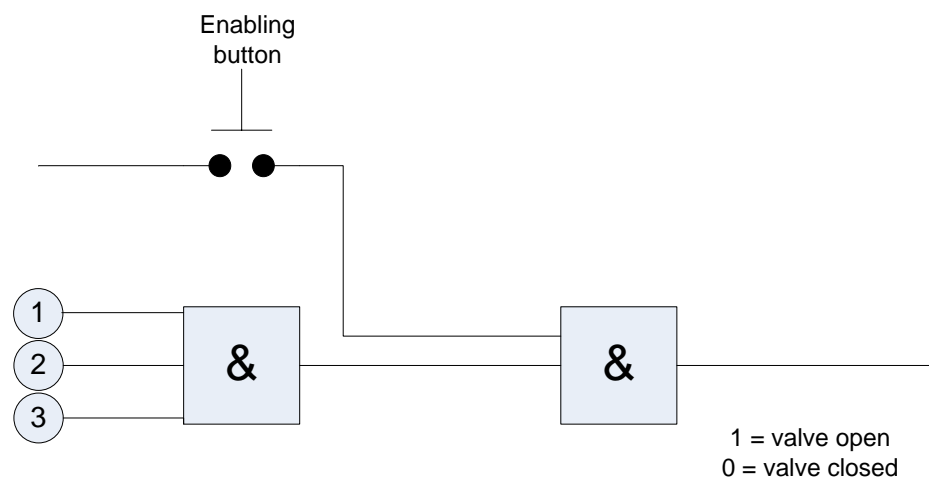

GS 5.23 All of the following conditions must be met (i.e. set at logic level 1) for the supply to be enabled:

Authorised Party condition met (e.g. new consumer identified, debt paid, gas leak, etc.)

Prepayment condition met (e.g. sufficient credit on meter)

Meter integrity condition met (e.g. tamper detection, reverse flow of gas).

	<p>When re-armed, restoration can be achieved via a button press as specified at GS.5.21.</p> <p>GS.5.24 Where a loss of supply has occurred for reasons beyond of the control of the gas meter (e.g. gas network failure or closure of the Emergency Control Valve) then, when the supply is restored, the meter shall retain the operational status of the internal Valve prior to the supply loss.</p>
Extended Narrative	<p>The term Authorised Party has yet to be agreed as a matter of governance. At the time of writing consideration is being given to the possibility of allowing the Gas Network Operator remote access to allow only for disablement purposes.</p> <p>It is assumed that in the event of network disablement arising from site safety issues, a Gas Safe approved operative would take the necessary action to ensure that the supply is re-established safely. This will probably require a "purge and relight" visit; such activity is beyond the scope of this requirement.</p>
Justification	High-level list F
Domestic/Non-domestic	Domestic
Use Case(s)	<p>UC02.08 Manage PAYG - Self-disconnect Supply</p> <p>UC 11.01 Enable Supply</p> <p>UC 12.01 Disable Supply</p> <p>UC 16 -Manage Load set</p> <p>UC29.01 Restart Supply</p>
Normative Reference(s)	<p>prEN16314</p> <p>EN 13611, or EN 13849, or EN 61508</p> <p>EN 60079-10, EN 60079</p>
Data Item Reference(s)	<p>Data Items:</p> <p>Valve Status</p> <p>Supply Status</p>
Security Requirement(s)	Access to the event log shall only be possible with the appropriate authorisation
Component(s) affected	SMS Components only

Prospectus Requirement	The Smart Metering System shall continue normal operation in the event of a gas supply interruption (Valve will retain state).
ID	GS.6
Extended Requirement	<p>GS.6.1 The state of the gas Valve shall not be affected by loss or restoration of gas supply.</p> <p>GS.6.2 gas meter functionality shall operate as normal, irrespective of whether the Valve is open or closed.</p> <p>GS.6.3 The operation and specification of the Valve shall meet the requirements of GS.5.4 (gas meter Valve requirements).</p> <p>GS.6.4 The meter display shall indicate the status of the Valve.</p>

Extended Narrative	This includes situations where the Valve has operated
Justification	High-level list A
Domestic/Non-domestic	D/ND
Use Case(s)	N/A
Normative Reference(s)	TC237 in part, European Specification for Smart Metering
Data Item Reference(s)	Data Items: Valve Status Supply Status
Security Requirement(s)	N/A
Component(s) affected	gas meter

Prospectus Requirement	The Smart Metering System Valve shall be configurable to either retain state or be closed in the event of battery failure.
ID	GS.7
Extended Requirement	<p>GS.7 The Smart Metering System Valve shall be configurable to either retain state or be closed in the event of battery failure.</p> <p>GS.7.1 If the meter is configured to allow it, removal of the main battery in a gas meter shall not cause the Valve to close during a battery exchange.</p> <p>GS.7.2 As the battery approaches the end of its life, the gas meter shall respond by following a set of configurable rules (see also DI.02):</p> <ul style="list-style-type: none"> • When 10% of the main battery lifetime remains, the gas meter shall generate a “low battery” alert • Prior to end of life battery failure, the meter shall generate a “battery fail” alert and, subject to configuration, close the Valve • When the battery fail alert has been triggered, battery use shall be prioritised as follows: <ol style="list-style-type: none"> 1) Safety 2) Metrology 3) Data-logging 4) Communications 5) Valve operation.
Extended Narrative	<p>Allows configuration for a number of scenarios.</p> <p>Note: Operation of the shut-off mechanism may be inhibited in some cases; e.g. vulnerable consumers.</p>
Justification	Consumer
Domestic/Non-	D/ND

domestic	
Use Case(s)	N/A
Normative Reference(s)	Not Applicable
Data Item Reference(s)	Thresholds and Triggers Severity Threshold High Limit Threshold Low Limit Threshold Type Action ID Action Type Instruction on Action (this field may be set to specify that Valve should be open or closed should this event occur). Action Description
Security Requirement(s)	SP.18, SP.19, SP.20, SP.21, SP.22, SP.24, SP.25, SP.182, SP.6
Component(s) affected	Gas meter

Prospectus Requirement	The Smart Metering System shall support 15 years' battery life under normal working conditions including prepayment operation.
ID	GS.8
Extended Requirement	The Smart Metering System shall support 15 years' battery life under normal working conditions including prepayment operation.
Extended Narrative	The supporting documentation and analysis is contained within the working group report (ref: Battery Life working group report version 2.0).
Justification	High-level list F
Domestic/Non-domestic	D
Use Case(s)	Non Functional
Normative Reference(s)	Battery connection and replacement shall fulfil the requirements of the ATEX directive and Battery Directive 2006/66/EC
Data Item Reference(s)	
Security Requirement(s)	N/A
Component(s) affected	Gas meter

Prospectus Requirement	The Smart Metering System shall check if there is uncontrolled gas flow at the point of local acknowledgement at re-enablement.
------------------------	---

ID	GS.10
Extended Requirement	<p>GS.10 The Smart Metering System shall check if there is uncontrolled gas flow at the point of physical interaction with the meter after re-arming.</p> <p>GS.10.1 The Valve shall not be capable of opening without confirmation checks that the household side of the network is closed. The Valve opening function requires the following protection:</p> <ul style="list-style-type: none"> • Instruct the consumer to check appliances are off AND • Require the consumer's confirmation AND • Incorporate a check within the meter for uncontrolled release of gas. <p>GS.10.2 Technical implementations must operate with self-igniting boilers or have an override facility for this feature.</p> <p>GS.10.3 The check for uncontrolled flow of gas shall be enabled or disabled via a command from an Authorised Party.</p>
Extended Narrative	Added for safety reasons.
Justification	High-level list A
Domestic/Non-domestic	D
Use Case(s)	<p>Relevant Use Case is:</p> <p>UC 21 Restart Supply</p>
Normative Reference(s)	prEN16314 (Committee draft at time of writing)
Data Item Reference(s)	<p>Data Items are:</p> <p>Meter Configuration Data:</p> <p>ACTION_DESCRIPTION, e.g. Valve open to flow ACTION_ID ACTION_TYPE ACTION_PARTICIPANT_ID ACTIVITY_ID, e.g. integer to refer to at least 4000 events 4/week for 20 year different count per event code TIME/DATESTAMP (Clock time to 1 minute resolution) VALVE_FLOW_MESSAGE char(32) VALVE_RETRY_LIMIT RETRY_PERIOD_TIMEOUT INTERLOCK_TYPE MAXIMUM_PRESSURE_DIFFERENCE Integer mBar</p>
Security Requirement(s)	SP.24
Component(s) affected	Gas meter

Diagnostics Requirements

1.103. The diagnostics requirements cover the need for an agreed set of configuration and diagnostics data that can be stored and accessed by third parties.

Prospectus Requirement	The Smart Metering System shall support logging of meter events such as faults, tampers, thresholds associated with extreme levels, etc. This will include, but is not limited to, the time and date stamping and recording of the originating device for the event.
ID	DI.1
Extended Requirement	<p>DI.1 The Smart Metering System shall support logging of meter events such as faults, tampers, thresholds associated with extreme levels, etc. The minimum requirement shall include the time and date stamping, and recording of the originating device for the event.</p> <p>The following requirements should be viewed in conjunction with the Events Definition table found in the appendices</p> <p>DI.1.1 The Smart Metering System shall be capable of monitoring the relevant parameters and recognising when defined events have occurred, upon which it shall:</p> <ul style="list-style-type: none"> • Recognise that an event has occurred • Record the event • Take configurable action (e.g. send an alert to the DCC as per DI.3, interrupt supply as per ES.12, etc.). <p>DI.1.2 Smart Metering System events (alerts, faults or tampers) shall be date and time stamped as per OP.2, and stored in non-volatile memory (in one or more event logs). As a minimum this log shall be stored in the component where the event originated.</p> <p>DI.1.3 In the case of a component constructed in a modular fashion, the events shall also include a means of identifying the individual module where the event originated. For example, in an electricity meter/WAN unit, the originating component/device/module shall be identified.</p> <p>DI.1.4 Event logs shall be capable of recording and storing event data sufficient to support obligations for Authorised Parties (e.g. the Supplier) through the life of the Smart Metering System (e.g. prioritised long term storage of tampers/hardware/processor alerts), and shall be available remotely.</p> <p>DI.1.5 Event logs shall retain their data on decommissioning / un-pairing / change of supply of the originating device(s).</p> <p>DI.1.6 Each event, group or class of events shall have configurable rules for: Treatment (e.g. transmit immediately to DCC, transmit on next transaction, suppress but retain in meter log, etc.)</p> <p>Actions resulting when the alert occurs (e.g. interrupt supply, flag to consumer via meter and via IHD, switch to prepayment mode).</p> <p>DI.1.7 Events that are sent to the DCC/Headend shall follow the requirements of WA.3.</p> <p>DI.1.8 The occurrence of an event shall, where configured, be transmitted to DCC/Headend immediately upon occurrence, or, in cases involving loss of power, as soon as is reasonably practicable.</p> <p>DI.1.9 The Smart Metering System shall make the log entries remotely available to</p>

	<p>the DCC/Headend.</p> <p>DI.1.10 The Smart Metering System shall respond to the events specified in the 'Events Definition table' in the ESODR appendix in accordance with the configurable rules associated with each entry.</p> <p>DI.1.11 The Smart Metering System event logs shall be capable of recording a minimum of 100 event entries.</p> <p>DI.1.12 The event logs shall follow the First In First Out (FIFO) principle.</p> <p>DI.1.13 The event logs shall be permanently enabled, and only event types configured to be active/inactive shall be logged as detailed in DI.2.</p> <p>DI.1.14 The events within a log(s) shall be capable of being cleared remotely by the relevant Authorised Party. Suppliers should not clear the entries specific to other Authorised Parties without agreement.</p> <p>DI.1.15 The event log shall be activated during manufacture and cannot subsequently be disabled.</p>
Extended Narrative	
Justification	High-level list B
Domestic/Non-domestic	D/ND
Use Case(s)	UC 04 Manage Events – Set Event Parameters and Rules UC 04.02 Manage Events - Respond to event
Normative Reference(s)	None
Data Item Reference(s)	See all Thresholds and Triggers and Logging data items
Security Requirement(s)	SP.18-21 and SP.42-50 apply
Component(s) affected	All SMS components

Prospectus Requirement	The Smart Metering System shall support remote configuration of logs, alarms and thresholds
ID	DI.2
Extended Requirement	<p>DI.2 The Smart Metering System shall support remote configuration of logs, alarms, thresholds and events.</p> <p>The following requirements should be viewed in conjunction with the Events Definition table found in the appendices</p> <p>DI.2.1 All events defined in the appendices shall be configurable to be either active, or inactive, on Authorised Party request. The request can be made via either the DCC/Headend or through the use of an authorised HHT.</p> <p>DI.2.2 The 'configuration settings' for all events (including faults, tampers and alerts) should have an effective 'from' date and time, as per DI.1.2</p> <p>DI.2.3 The Smart Metering System / sequence number shall be configurable so that when an event occurs:</p> <ul style="list-style-type: none"> Record the occurrence of the event with appropriate timestamp / sequence

	<p>number in the appropriate event log</p> <ul style="list-style-type: none"> • Communicate the event via an alert/alarm in accordance with DI.2.4 • Indicate the occurrence, recognise and record each instance of an event on the defined Smart Metering components. Please see DI.1 for detailed requirements • Disable the supply. <p>DI.2.4 Events can be configured to send an alert/alarm to the DCC/Headend. They may be configured to send an alert immediately or sent in the next scheduled communications session.</p> <p>DI.2.5 During a mode change, as detailed in PC.01, the Smart Metering System shall retain the current event settings and configuration, logs, and thresholds, unless a new configuration is sent with the remote mode change instruction.</p> <p>DI.2.6 Local alerts/messages shall be made available over the SM HAN.</p>
Extended Narrative	<p>Suppliers and other Authorised Parties may wish to configure event definitions (as per DI.1) in different ways. This should be possible remotely without a site visit.</p> <p>For prepayment thresholds relating to debt repayments and low credit warnings, some configuration is available to the consumer, but these requirements are covered in the prepayment/credit section of the Statement of Design Requirements.</p>
Justification	High-level list B
Domestic/Non-domestic	D/ND
Use Case(s)	<p>UC 04 Manage Events – Set Event Parameters and Rules</p> <p>UC 04.02 Manage Events – Respond to event</p> <p>UC05.01 Manage parameters and configuration</p>
Normative Reference(s)	None
Data Item Reference(s)	<p>Thresholds and Triggers. In particular (but not limited to):</p> <p>Action Type</p> <p>Activity Base Message</p> <p>Audible Alert Type</p> <p>Consumer Adjustable Threshold</p> <p>Duration of Audible Alert</p> <p>Duration of Visual Alert</p> <p>Severity</p> <p>Threshold High Limit</p> <p>Threshold Low Limit</p> <p>Threshold Type</p> <p>Trigger Description.</p>
Security Requirement(s)	None
Component(s) affected	All Smart Metering System devices

Prospectus Requirement	The Smart Metering System shall support configuration of alarms associated with usage thresholds.
ID	DI.3
Extended Requirement	DI.3.1 Alarms shall be configurable as per DI.2.2 on exceeding a threshold of the following: <ul style="list-style-type: none"> • Maximum Demand (kW in a 30-minute period) • Energy limiting threshold (kW or kWh over a configurable period) • Reactive power threshold (kVAr over a 30-minute period) • Peak volume of gas over a 60-minute period.
Extended Narrative	To ensure, for example, measurements outside limits are registered.
Justification	High-level list B
Domestic/Non-domestic	D/ND
Use Case(s)	UC 04.01 Manage Events – Set Event Parameters and Rules
Normative Reference(s)	N/A
Data Item Reference(s)	Thresholds and Triggers In particular (but not limited to): Action Type Activity Base Message Audible Alert Type Consumer Adjustable Threshold Duration of Audible Alert Duration of Visual Alert Severity Threshold High Limit Threshold Low Limit Threshold Type Trigger Description.
Security Requirement(s)	SP.18, SP.19, SP.24, SP.30, SP.35
Component(s) affected	Electricity Meter, gas meter, Communications Hub

Prospectus Requirement	The Smart Meter shall store its configuration data in non-volatile memory.
ID	DI.4
Extended Requirement	DI.4 The Smart Metering System shall store any configuration data in non-volatile memory. DI.4.1 The meter shall log the following: <ul style="list-style-type: none"> • Any changes to configuration • Activation of new configuration

	<ul style="list-style-type: none"> Validation /configuration errors <p>DI.4.2 Any meter configuration change shall be acknowledged to the DCC/Headend.</p> <p>DI.4.3 On receipt of new configuration data the Smart Metering System shall immediately store the configuration data in non-volatile memory along with the date and time of activation.</p> <p>DI.4.4 The Smart Metering System shall reject the configuration data (see SP.18) if it is not complete with respect to the mandatory items. The Smart Metering System shall notify the DCC/Headend of any rejection.</p> <p>DI.4.5 In the event of power failure after the configuration data has been acknowledged, the Smart Metering System shall be capable of activating the new configuration on restoration of power. The Smart Metering System device shall only activate data that is still within its original format, or it shall follow the requirements in DI.4.3.</p>
Extended Narrative	To ensure, for example, that necessary information / data / settings remain after power loss.
Justification	High-level list B
Domestic/Non-domestic	D/ND
Use Case(s)	<p>Use Cases include:</p> <p>UC 14 : Update tariff</p> <p>UC 13.01 : Switch Between Credit and PAYG - Switch to PAYG</p> <p>UC 13.02: Switch Between Credit and PAYG - Switch from PAYG to Credit</p> <p>UC 2.10: Manage PAYG - set parameters</p> <p>UC 5: Manage parameters and configuration</p>
Normative Reference(s)	The Measuring Instruments (Active Electricity Energy Meters) Regulations SI 2006:1679
Data Item Reference(s)	<p>Meter Configuration Data</p> <p>Logging Data; in particular</p> <ul style="list-style-type: none"> Input snapshot (which will record the incoming message) <p>Thresholds and alerts (regarding configurable alert).</p>
Security Requirement(s)	SP.6, SP.7, SP.18, SP.20, SP.21, SP.22, SP.24, SP.26, SP.30, SP.31, SP.32, SP.33, SP.35
Component(s) affected	SMS devices with non volatile memory

Prospectus Requirement	The Smart Metering System components shall be identifiable within any diagnostic log information.
ID	DI.5
Extended Requirement	<p>DI.5.1 In the case of a component constructed in a modular fashion, the events shall include a means of identifying the individual module where the alert originated.</p> <p>DI.5.2 The identity of the local communication interface, including HHT asset details, shall be stored with log information during any locally initiated activity (for example, a local firmware upgrade).</p>
Extended Narrative	To ensure clear and unambiguous recognition/understanding. For more information refer to IM.5 and IM.6.
Justification	High-level list B

Domestic/Non-domestic	D/ND
Use Case(s)	N/A
Normative Reference(s)	Standard yet to be defined, dependent upon final design, possibly a UKMF reference and a gas meter reference will emerge
Data Item Reference(s)	See Logging Data In particular: MPAN MPRN Device Id Meter Register Id
Security Requirement(s)	SP.24, SP.25, SP.35, SP.36, SP.303, SP.42
Component(s) affected	All Components

Prospectus Requirement	The Smart Meter System shall communicate battery status for metrology related functionality.
ID	DI.6
Extended Requirement	DI.6.1 The Smart Metering System shall communicate battery status for metrology related functionality and provide appropriate warnings in the following scenarios: <ul style="list-style-type: none"> • After 90% of the battery's lifetime has expired; and • Immediately before the end of the battery's lifetime. DI.6.2 Appropriate warnings triggered after the events detailed in DI.6.1, such as meter flags and events/alerts, shall be communicated to the communications Hub. DI.6.3 Battery related events shall be accessible locally only by Authorised Parties, and shall not be accessible by the consumer. DI.6.4 The gas meter shall continually monitor the battery to obtain an estimate of remaining battery life. DI.6.5 To preserve battery life, the gas meter display shall 'go to sleep' (blank the display) when not in use and shall wake up on user interaction (e.g. button push).
Extended Narrative	The MID covering gas meters states that a warning has to be shown once 90% of the battery's lifetime has been reached (Annex MI-002, 5.2).
Justification	Regulatory
Domestic/Non-domestic	D/ND
Use Case(s)	UC 04.01 Manage events – Set event parameters and rules
Normative Reference(s)	N/A
Data Item Reference(s)	See Thresholds and Triggers and IHD

	Gas meter Battery Status Threshold Low Limit Trigger Id Trigger Description
Security Requirement(s)	SP.26
Component(s) affected	gas meter

HAN Requirements

1.104. The HAN requirements describe the expected functionality of the links between the devices that are on the HAN. They also call for a HAN solution that has some degree of future proofing given the emerging requirements of other "smart" applications such as water metering.

Prospectus Requirement	The HAN interface shall be based on open and non proprietary standards.
ID	HA.1
Extended Requirement	<p>HA.1.1 The HAN interface shall be available for adoption as a standard by 31st December 2014 as one of the following;</p> <ul style="list-style-type: none"> • A European (CEN, CENELEC or ETSI) • An International (IEC or ISO) standard • Formally accepted as a work item by a European or International Standards Organisation.
Extended Narrative	<p>The European definition of openness is satisfied if the following are met:</p> <ul style="list-style-type: none"> • All stakeholders have the same possibility of contributing to the development of the specification, and public review is part of the decision-making process • The specification is available for everybody to study • Intellectual property rights related to the specification are licensed on Fair, Reasonable and Non-Discriminatory (FRAND) terms, or on a royalty-free basis in a way that allows implementation in both proprietary and open source software. <p>Specific requirements for GB SM HAN functionality are considered acceptable if the work is carried out in a manner that complies with the above criteria. GB-specific requirements should be proposed to the bodies holding the over-arching standards as a method of demonstrating a commitment to openness.</p> <p>The European definition of proprietary (taken from the European Interoperability Framework v2 – 7.2 Glossary) is as follows:</p> <ul style="list-style-type: none"> • “Generally refers to specifications that are either partially or totally unpublished, or are only available from a single vendor for a substantial fee, and/or under restrictive terms, thus making the implementation and use by third parties of products that conform to the given specifications subject to control.”
Justification	High-level list C
Domestic/Non-domestic	D/ND
Use Case(s)	None
Normative Reference(s)	IFRS CWA 50560
Data Item	None

Reference(s)	
Security Requirement(s)	None
Component(s) affected	Electricity Meter, gas meter, IHD, Communications Hub

Prospectus Requirement	The HAN interface shall only support authorised devices (i.e. no unauthorised linking of devices).
ID	HA.2
Extended Requirement	The SM HAN shall support only Approved SM HAN Devices (i.e. no direct linking of Unapproved Devices to the SM HAN).
Extended Narrative	<p>HA2.1 SM HAN Devices will comply with the Security Requirements. Of particular relevance to this requirement are: SP.51 and SP.52</p> <p>HA2.2 Smart Metering HAN (SM HAN) is the term used to describe the HAN which connects meters, Communications Hub and IHD in the home. This is to avoid confusion with other 'HANs' which are not the SM HAN.</p> <p>HA2.3 Devices that have been Approved for connection to the SM HAN will be called "Approved SM HAN Devices". All other devices will be called "Unapproved Devices" as far as the SM HAN is concerned.</p> <p>HA2.4 A number of device types have been defined by the SM HAN WG to help clarify what Devices can be attached to the SM HAN.</p> <p>The definitions are:</p> <ul style="list-style-type: none"> • Approved SM HAN Device: These Devices have been Approved for direct connection to GB SM HANs. They may be identified with an approval Mark. • Authenticated SM HAN Device: An Approved Device that has been authenticated for attachment to a specific SM HAN. • Active SM HAN Device: An Authenticated Device that is currently operating on a specific SM HAN • Gateway SM HAN Device: An Approved SM HAN Device which includes an interface to other devices outside the SM HAN (e.g. home energy management systems) • Unapproved Device: Any device which is not approved for direct connection to an SM HAN. <p>HA2.5 Authorisation may be achieved by processes including steps such as identification at the device and communication with the supplier.</p>
Justification	High-level list C
Domestic/Non-domestic	D/ND
Use Case(s)	UC 01.04 Commission Smart Metering System - Exclude device from HAN
Normative Reference(s)	N/A
Data Item Reference(s)	<p>Data items will be required to identify trust levels for classes of device and individual devices (allowed values in <i>italics</i>) as follows:</p> <p>Device approval status (definitions as above)</p>

	<p>01 - Approved SM HAN Device 02 - Gateway SM HAN Device</p> <p>Authentication status (definitions as above)</p> <p>01 - Authenticated SM HAN Device 02 - Active SM HAN Device 03 - Unapproved Device</p> <p>Trust Level</p> <p>01 - Trusted 02 - Not Trusted</p>
Security Requirement(s)	SP.56, SP.58
Component(s) affected	Electricity Meter, gas meter, IHD, Communications Hub

Prospectus Requirement	The HAN interface shall support real-time (better than ten seconds, target of five seconds) two way communication from mains powered nodes.
ID	HA.3
Extended Requirement	<p>HA.3.1 The SM HAN shall support real-time two-way communication from mains-powered nodes.</p> <p>HA.3.2 "Real Time" in this context means a target communications interval of five seconds, and a minimum acceptable frequency of ten seconds.</p>
Extended Narrative	This enables real-time updates to IHDs.
Justification	High-level list C
Domestic/Non-domestic	D/ND
Use Case(s)	UC 19.01
Normative Reference(s)	N/A
Data Item Reference(s)	This is a performance requirement, rather than data modelling requirement.
Security Requirement(s)	N/A
Component(s) affected	Electricity Meter, IHD, Communications Hub

Prospectus Requirement	The HAN interface shall be certified and tested for interoperability.
ID	HA.5
Extended	HA.5 SM HAN devices shall be certified as being interoperable through an appropriate process carried out by an authorised approval body, in accordance with

Requirement	the Interoperability Principles. HA.5.1 SM HAN solutions shall be certified as meeting all requirements set out in the HAN Evaluation Criteria appendix.
Extended Narrative	All devices which require to be connected to any GB SM HAN should include certification. Depending on the relevant governance of the technical specification and the applicable European or International standards, this could include tests for interoperability of devices from different manufacturers, or test houses.
Justification	High-level list C
Domestic/Non-domestic	D/ND
Use Case(s)	None
Normative Reference(s)	IEC 17011, IEC 17025, IEC 17043
Data Item Reference(s)	Data items will be required to identify trust levels for classes of device and individual devices allowed values as follows: Device approval status (definitions as above) 01 - Approved SM HAN Device 02 - Gateway SM HAN Device Authentication status (definitions as above) 01 - Authenticated SM HAN Device 02 - Active SM HAN Device 03 - Unapproved Device Trust Level 01 - Trusted 02 - Not Trusted.
Security Requirement(s)	None
Component(s) affected	Electricity Meter, gas meter, IHD, Communications Hub

Prospectus Requirement	The HAN interface shall support load and device control events
ID	HA.7
Extended Requirement	HA.7.1 The SM HAN shall support the transfer of load control commands (from Authorised Parties) to SMS authorised load controlled contactors or switches. HA.7.2 The SM HAN shall be capable of supporting multiple authorised load control events in a 24-hour period.

	<p>HA.7.3 Commands may be deferred or declined according to tariff and contractual arrangements between the consumer and the supplier.</p> <p>HA.7.4 Load control shall be initiated when a defined tariff period becomes active. For avoidance of doubt, the nominal duration for load control does not have to be the same as a defined tariff period, but shall occur within the defined tariff period. The actual operating times for load control may be subject to configurable randomisation from the nominal times.</p> <p>HA.7.5 Consumers shall be able to see the status of an SMS Meter-initiated Load Control event (on/off time) on their SMS Meter. The SMS meter shall be capable of transmitting this status to an authorised SM HAN device through the SM HAN (e.g. to an IHD).</p> <p>HA.7.6 The SM HAN should be capable of supporting authorised additional load controlled appliances, for example, Electric Vehicles.</p>
Extended Narrative	
Justification	High-level list C
Domestic/Non-domestic	D/ND
Use Case(s)	UC 16 UC 20
Normative Reference(s)	BS60947-3 Low Voltage Switch Gear and Control Gear BS7951 Specification for Electricity Meters - Alternating-Current Single-Phase Static Watt-Hour Telemeters of Accuracy Class 1 or 2
Data Item Reference(s)	Boost Activated Boost available Boost Enabled Boost Remaining Boost Step Random Offset Random Offset Enabled Random Offset Scalar Supply Status DateTime Cancelled DateTime Created Effective From Date/Time Effective To Date/Time Element 1 Immediate Rate Element 2 Immediate Rate Element Register Identifier Group Code Switch Number Switch On Status Switch Type Switching Period Id Switching Period Off

	Switching Period On Variant Reference
Security Requirement(s)	SP.29, SP.51, SP.54, SP.56, SP.57, SP.58
Component(s) affected	Electricity meter, IHD, any SM HAN-controlled contactor

Prospectus Requirement	The HAN interface shall support the use of repeaters, boosters, and other devices of equivalent function, to extend range.
ID	HA.9
Extended Requirement	The SM HAN shall support optional additional equipment that can be installed to extend communications range in cases where direct communications between SM HAN devices cannot be established or sustained. Any such devices shall comply with all other requirements applicable to SM HAN Devices.
Extended Narrative	<p>HA 9.1 Examples of such devices are RF repeaters and RF/PLC bridge devices. Requirement OP.01 refers to the use of this type of device, particularly to provide connection to gas meters where power to the range extension cannot be guaranteed.</p> <p>HA9.2 All SM HAN solutions will have range issues in some percentage of deployments and therefore the ability to extend range to ensure good communications is essential. For example, some RF-based SM HAN solutions support the use of repeaters to relay a message to a node that cannot be reached directly, as might be used to provide a link to an IHD that is used remotely from where meters are installed.</p> <p>HA9.3 Use of boosters/repeaters should be mindful of OP.04 to keep power consumption of Smart Metering System installations in line with expectations.</p>
Justification	High-level list C
Domestic/Non-domestic	D/ND
Use Case(s)	N/A
Normative Reference(s)	N/A
Data Item Reference(s)	<p>This requirement is physical rather than relating to data content. It may be necessary to identify such devices within the SM HAN, in which case see Device Data and Network Data. In particular, see:</p> <p>Device ID Device Type Received Signal Strength Indicator.</p>
Security Requirement(s)	N/A

Component(s) affected	Electricity Meter, gas meter, IHD and Communications Hub
-----------------------	--

Prospectus Requirement	The HAN interface shall support acknowledgement of signals.
ID	HA.10
Extended Requirement	The SM HAN shall support acknowledgement of messages.
Extended Narrative	This is required for occasions where a delivery receipt is required for messages moving from one SM HAN device to another SM HAN device.
Justification	High-level list C
Domestic/Non-domestic	D/ND
Use Case(s)	N/A
Normative Reference(s)	N/A
Data Item Reference(s)	Network Data In particular: Read Acknowledgement Flag (for incoming messages)
Security Requirement(s)	
Component(s) affected	Electricity Meter, gas meter, IHD, Communications Hub

Prospectus Requirement	The HAN interface shall support 30-minute update (wake-up) frequency from battery powered nodes.
ID	HA.11
Extended Requirement	HA.11.1 The SM HAN shall allow communications from an Approved Device whenever it is not communicating with another Approved Device. This is needed to support communications with Battery Powered Devices such as gas meters, typically every 30 minutes. This allows those Battery Powered Devices to put their SM HAN communications into an idle or inactive state in the intervening period, to preserve battery life whilst enabling reasonably frequent consumption updates. HA.11.2 The SM HAN shall be capable of supporting a more frequent 'wake up' activity for self-disconnected customers with an Enduring Prepayment Interface.
Extended Narrative	It is recognised that a 15-year battery life for a gas meter is not compatible with the demands of real-time communication, therefore a lower frequency for real-time updates is appropriate for battery-powered Approved Devices such as Gas meters.
Justification	High-level list C
Domestic/Non-	D/ND

domestic	
Use Case(s)	N/A
Normative Reference(s)	N/A
Data Item Reference(s)	This requirement is physical rather than relating to data content
Security Requirement(s)	SP.56
Component(s) affected	Gas meter, Communications Hub

Prospectus Requirement	The HAN interface firmware shall be remotely and locally upgradeable
ID	HA.12
Extended Requirement	<p>HA.12 The SM HAN shall support remote and local upgrade of firmware in SM HAN devices.</p> <p>HA.12.1 Software should follow the WELMEC Software Guide as appropriate.</p> <p>HA.12.2 All firmware shall be identified by version number, and version control processes shall be used by the manufacturers. The manufacturer shall employ quality assurance procedures and processes. All such processes shall be certified against BS EN ISO 9001 or equivalent.</p> <p>HA.12.3 The Smart Metering System shall support remote and local firmware upgrades. In the event of a failure to upgrade, the firmware shall revert to the version prior to the attempted upgrade, either automatically or by virtue of a remote command. It shall not require a site visit to revert to previous versions of firmware.</p> <p>HA.12.4 All Smart Metering System components that are capable of firmware upgrade shall have the facility to do so remotely and independently of each other, activating a new image either immediately or at a future date.</p> <p>HA.12.5 It shall be possible to apply an upgrade or completely overwrite a component's firmware.</p> <p>HA.12.6 The firmware version shall be stored within the device and be made available to the DCC/Head-end on request.</p>
Extended Narrative	This recognises that SM HAN firmware and SM HAN device functionality changes over time, and that devices deployed in the field will need to be upgraded as new features and fixes are released. Such upgrades must not cause disruption for the consumer.
Justification	High-level list C
Domestic/Non-domestic	D/ND
Use Case(s)	UC.06 Update Firmware
Normative Reference(s)	None stated

Data Item Reference(s)	<p>Device Data.</p> <p>In particular items:</p> <ul style="list-style-type: none"> • Firmware Id, • Firmware Image, • Firmware Install DateTime, <p>Firmware Version Meter Configuration Data Date Time Created Date Time Cancelled</p>
Security Requirement(s)	SP.1, SP.7, SP.11, SP.12, SP.13, SP.14, SP.18.
Component(s) affected	Electricity Meter, gas meter, Communications Hub, IHD

Prospectus Requirement	The HAN interface shall support authorised gateway/bridging devices to access data made available on the HAN.
ID	HA.13
Extended Requirement	HA.13.1 The SM HAN shall support Approved Gateway SM HAN Devices to data available on the SM HAN (e.g. by home energy management systems and through interfaces to download consumption data).
Extended Narrative	<p>Gateway SM HAN Devices are Approved SM HAN Devices that may be connected directly to the SM HAN. They may contain one or more other interfaces, allowing connections to devices outside the SM HAN (e.g. by home energy management systems, and to an interface to download consumption data).</p> <p>A set of Application Programming Interfaces will be defined and published for Gateway SM HAN Devices, setting out:</p> <ul style="list-style-type: none"> • What information can be written via the Gateway into the SM HAN. • What information can be read by the Gateway from the SM HAN.
Justification	High-level list C
Domestic/Non-domestic	D/ND
Use Case(s)	N/A
Normative Reference(s)	N/A
Data Item Reference(s)	<p>Device Data:</p> <p>Device Id Device Type Device Approval Status PIN.</p>

	<p>Network Data:</p> <p>Device Id</p> <p>Device Address.</p> <p>Prepayment Data:</p> <p>Data Restricted By PIN Flag.</p>
Security Requirement(s)	None
Component(s) affected	Communications Hub

Prospectus Requirement	The HAN shall support a defined application profile for devices that connect to the HAN. This profile shall support the Smart Metering services, meter requirements and IHD requirements defined in the Catalogue.
ID	HA.14
Extended Requirement	HA.14.1 The SM HAN shall utilise the Smart Energy Profile v1.x as the application profile for devices that connect to the SM HAN.
Extended Narrative	<p>Use of this published profile will deliver interoperable data exchanges between SM HAN Devices. It is anticipated that a specific GB companion version of the Smart Energy Profile is required to support the Data Catalogue and that it will be published in readiness for mass roll out. Smart Energy Profile 1.x is being developed to support and interoperate with DLMS/COSEM.</p> <p>Ongoing compatibility of the Application Layer is covered by HA.21.</p> <p>The Smart Energy Profile is being agreed as a European Standard – see Normative References, below, for reference.</p>
Justification	High-level list C
Domestic/Non-domestic	D/ND
Use Case(s)	N/A
Normative Reference(s)	Smart Energy Profile v1.x, as published and maintained by the ZigBee Alliance. Same standard is also Draft CENELEC EN 52056/EN 52075
Data Item Reference(s)	<p>Network Data, in particular:</p> <p>Application Profile Description</p> <p>Application Profile Id</p>
Security Requirement(s)	None
Component(s) affected	Electricity Meter, gas meter, IHD, Communications Hub

Prospectus Requirement	The HAN shall support alphanumeric messaging.
------------------------	---

ID	HA.15
Extended Requirement	HA.15.1 The SM HAN shall support alphanumeric messaging (e.g. messages sent to consumers for display on an advanced IHD, such as “your next account statement will be on [date]”).
Extended Narrative	This requirement is needed to support the display of messages to the consumer on the IHD, user interaction with touch screens on advanced IHDs, etc.
Justification	High-level list C
Domestic/Non-domestic	D/ND
Use Case(s)	UC 07.01 Provide Message for Display
Normative Reference(s)	N/A
Data Item Reference(s)	Not a specific modelling requirement, each item is categorised according to data type supported.
Security Requirement(s)	None
Component(s) affected	Electricity Meter, gas meter, Communications Hub, IHD and other SM HAN enabled devices such as micro-generation meters,

Prospectus Requirement	The HAN shall support the security and privacy requirements.
ID	HA.16
Extended Requirement	The SM HAN shall support the security and privacy requirements.
Extended Narrative	Please see the security requirements.
Justification	Security and privacy
Domestic/Non-domestic	D/ND
Use Case(s)	NA
Normative Reference(s)	NA
Data Item Reference(s)	<p>Access Control is mostly the responsibility of the DCC, with the metering system identifying that the other party communicating with it is the DCC.</p> <p>Other precise security mechanisms are yet to be defined but these will include the following data items:</p> <p>Device Data and Network Data Certificate Device and IHD Data PIN</p>

	Prepayment Data Payment UTRN Network HAN Network Key
Security Requirement(s)	All
Component(s) affected	Electricity Meter, gas meter, IHD, Communications Hub

Prospectus Requirement	The HAN shall be capable of supporting other utility meters where the data or physical (e.g. range) requirements do not exceed those of gas and electricity Smart Meters.
ID	HA.17
Extended Requirement	<p>HA17.1 The SM HAN shall be capable of supporting other utility meters where the data or physical (e.g. range) requirements do not exceed those of gas and electricity Smart Meters. Examples of such meters are for measuring water, heat, micro-generation etc.</p> <p>HA17.2 Where another utility meter is installed within the premises then, subject to appropriate security measures, the SM HAN will facilitate connection of the meter as an SM HAN-connected device. This shall facilitate the transmission of data and provide for remote configuration, software and firmware updates. For example micro generation data could be transmitted to and stored within the SM HAN.</p>
Extended Narrative	<p>Some examples of other utility meters are:</p> <ul style="list-style-type: none"> • Water meters • Heat meters • Micro-generation meters.
Justification	High-level list H
Domestic/Non-domestic	D/ND
Use Case(s)	UC 15.04 UC 09.05
Normative Reference(s)	<p>MID</p> <p>BS EN 50470-3:2006 Electricity metering equipment (a.c.). Particular requirements. Static meters for active energy (class indexes A, B and C)</p> <p>BS EN 62052-11 Electricity metering equipment (AC) - General requirements, tests and test conditions - Part 11: Metering equipment.</p>
Data Item Reference(s)	<p>Data Items include:</p> <p>Measurement Quantity</p> <p>Meter ID (Serial Number)</p> <p>DataTime Created</p> <p>Meter Register ID</p> <p>Generation Technology Type</p>
Security	SP.52, SP.53, SP.55, SP.56, SP.58

Requirement(s)	
Component(s) affected	Communications Hub

Prospectus Requirement	The HAN shall support addition of new devices classes
ID	HA.19
Extended Requirement	<p>HA.19.1 The SM HAN must be capable of allowing new devices to be joined to the SM HAN.</p> <p>HA.19.2 New device classes shall meet the requirements of the published specification for SM HAN devices.</p> <p>HA.19.3 New SM HAN devices shall be approved and meet the security requirements before being allowed to join the SM HAN.</p> <p>HA.19.4 Approved and paired SM HAN devices shall be capable of being authenticated via the DCC/Headend.</p>
Extended Narrative	<p>Whilst most SM HAN technologies will generally be agnostic to device or application, it is desirable for the SM HAN to be flexible. This will allow, within the physical, security, technical and capacity constraints of the SM HAN, for it to be considered for a range of potential future devices and applications within the smart grid, load control and demand response, and other similar activities.</p> <p>In order to lessen security risks to the SM HAN, the general principle is that devices should be connected to the SM HAN on a 'need to be there' basis. So, devices that might form part of a contract between a supplier and a customer (e.g. a micro-generation meter) can be Approved and Authorised for connection directly to the SM HAN. Approval of Devices shall be as described in HA.2 and HA.5.</p> <p>Other devices and systems not part of the SM HAN may be connected only via an Approved SM HAN Gateway. These would not be part of the SM HAN, but part of a separate HAN. This will provide opportunities for third-party companies to create innovative products that will further enhance the benefits of the Smart Metering programme, whilst minimising costs to energy suppliers and risks to the integrity and security of the Smart Metering System.</p>
Justification	High-level list C
Domestic/Non-domestic	D/ND
Use Case(s)	<p>UC 1.03 Commission HAN Device</p> <p>UC 18.01 Configure Device Relationships</p>
Normative Reference(s)	None
Data Item Reference(s)	<p>See Device Data</p> <p>In particular:</p> <p>Device Type</p>

	Device approval status Authentication status Trust Level.
Security Requirement(s)	SP.1, SP.7, SP.30, SP.31, SP.301, SP.302, SP.304, SP.51, SP.52, SP.56, SP.57, SP.58
Component(s) affected	Communications Hub

Prospectus Requirement	The HAN shall be backwards compatible.
ID	HA.20
Extended Requirement	<p>HA.20 The SM HAN solution(s) shall maintain backward compatibility for a minimum of 15 years from the date of manufacture.</p> <p>HA.20.1 Suppliers of SM HAN devices shall ensure that older devices will not fail as a result of attempting to:</p> <ul style="list-style-type: none"> Load software intended for newer devices Respond to requests intended for newer devices. <p>HA.20.2 Suppliers of SM HAN devices shall provide technical support for devices and products that were manufactured up to 15 years ago.</p> <p>HA.20.3 Newer SM HAN devices shall continue to interoperate with devices that were manufactured up to 15 years prior to their own date of manufacture.</p>
Extended Narrative	<p>SM HAN solutions have to be supported for at least 15 years, to avoid technical obsolescence or asset-stranding issues (the expected asset life of metering equipment is at least 15 years). Therefore irrespective of any new features or bug fixes introduced for the SM HAN, basic functionality of the SM HAN should remain intact, and existing deployed devices must continue to work satisfactorily.</p> <p>Where older devices are present in a SM HAN, the functionality of the SM HAN may be limited by the functionality of the older devices – new firmware updates or bug fixes can be accommodated only within the constraints of the original design (e.g. recognising memory constraints etc.).</p> <p><u>The requirement can be illustrated thus:</u></p> <p>The diagram illustrates the requirement for backward compatibility across four HAN versions: HAN v1 (2014), HAN v2 (2020), HAN v3 (2030), and HAN v4 (2036). Three components are tracked: GM (red), EM (blue), and CH (green). Each component has two versions, #1 and #2. GM #1 is supported from 2014 to 2030, and GM #2 from 2020 to 2036. EM #1 is supported from 2014 to 2030, and EM #2 from 2020 to 2036. CH #1 is supported from 2014 to 2020, and CH #2 from 2020 to 2036. Dotted arrows indicate that newer versions of components must be able to interact with older versions of the same component.</p>

	<p>All SMS equipment installed in 2014 operates using HAN v1.</p> <p>In 2020, the Communications Hub (CH) is replaced – this is within the 15-year window, and so while the Communications Hub could support HAN v2, it has to support the Gas and Electricity meters – everything remains HAN v1.</p> <p>In 2030, the gas meter (GM) is exchanged – the HAN is now on v3, with additional features or functionality. It is more than 15 years since the Electricity meter was installed, so there is no obligation for the Gas meter HAN chip to support it. However, the Communications Hub is 10 years old, and has to be supported, and was also on v1. In this scenario, if the HAN v1 and HAN v2 can co-exist for different meters, the Gas meter link could be HAN v2.</p> <p>In 2036, the Electricity Meter is exchanged – the HAN is now on v4. The meter has to support the six year old Gas meter HAN chip on v3, but not the 16 year old Communications Hub on v1. The implication is that the Communications Hub would also need to be updated to support the ‘next generation’ Electricity Meter.</p> <p>This ‘rolling’ 15-year support window will actually result in longer windows of functional support and backwards compatibility for the SM HAN, depending on the generational release schedule for SM HAN solutions.</p> <p>At the same time, it allows for newer technology features to develop and to be deployed to achieve performance or cost benefits. It could also result in older equipment having to be replaced due to lack of support for ‘old’ HAN hardware.</p>
Justification	High-level list A
Domestic/Non-domestic	D/ND
Use Case(s)	UC 1.03 UC 18.01
Normative Reference(s)	N/A
Data Item Reference(s)	<p>Software and Firmware used on the Smart Metering System will be identifiable by version number.</p> <p>Relevant data items include:</p> <ul style="list-style-type: none"> Firmware Id Firmware Version Software Id Software Version Application Profile Id.
Security Requirement(s)	None
Component(s) affected	Electricity Meter, gas meter, IHD, Communications Hub

Prospectus Requirement	The HAN applications profile shall be used by all Smart Metering System components in a consumer premises where possible.
ID	HA.21
Extended Requirement	The SM HAN shall use a consistent Application Layer.
Extended Narrative	<p>It is expected that different HAN technologies or HAN physical media might be required to provide SM HAN coverage for all building types and meter locations.</p> <p>It might be necessary to use a wired/power-line option, or in some cases a specialist radio in order to achieve a reliable connection.</p> <p>It is expected that the range of potential HAN physical media will be limited to preferred/approved options to provide interoperability.</p> <p>As long as the solutions used are capable of transporting a common Application Layer, the differences in physical media will not affect the delivery of functionality.</p> <p>How commonality/transparency of the Application Layer is technically achieved is not critical – e.g. ‘tunnelling’ solutions are acceptable.</p>
Justification	High-level list A
Domestic/Non-domestic	D/ND
Use Case(s)	N/A
Normative Reference(s)	None – derived from HA.14
Data Item Reference(s)	N/A
Security Requirement(s)	None
Component(s) affected	Electricity Meter, gas meter, IHD, Communications Hub

Prospectus Requirement	The HAN shall not interfere with existing prevalent premises networks.
ID	HA.22
Extended Requirement	HA.22.1 The existence of a SM HAN shall not cause existing prevalent premises networks to either stop working effectively, or to perform in an unacceptable way.
Extended Narrative	Consumers and businesses are likely to have existing networks installed for data, voice, video, etc. These networks may be wired or wireless. The consumer should expect these networks to continue to work acceptably after the installation of the SM HAN.

Justification	High-level list A
Domestic/Non-domestic	D/ND
Use Case(s)	None
Normative Reference(s)	Radio and Telecommunications Terminal Equipment (R&TTE) Directive - 1999/5/EC Electromagnetic Compatibility (EMC) Directive – 2004/108/EC
Data Item Reference(s)	This requirement is physical rather than relating to data content
Security Requirement(s)	None
Component(s) affected	Electricity Meter, gas meter, IHD, Communications Hub

WAN Requirements

1.105. The WAN requirements describe the expected functionality of the link between the premises and DCC. The key parameters of bandwidth, availability and latency (responsiveness) are subject to the level of traffic associated with DCC services. It has been recognised that as requirements emerge it may be necessary to upgrade the WAN without replacing the meter.

Prospectus Requirement	The WAN interface shall be based on open and non proprietary standards.
ID	WA.1
Extended Requirement	The Application Data Layer shall be based on open and non proprietary standards.
Extended Narrative	<p>WA.1.1 The European definition of openness is satisfied if the following are met:</p> <ul style="list-style-type: none"> • All stakeholders have the same possibility of contributing to the development of the specification and public review is part of the decision-making process • The specification is available for everybody to study • Intellectual property rights related to the specification are licensed on Fair, Reasonable and Non Discriminatory (FRAND) terms or on a royalty-free basis in a way that allows implementation in both proprietary and open source software. <p>WA.1.2 The European definition of proprietary (taken from the European Interoperability Framework v2 –7.2 Glossary) is as follows; “Generally refers to specifications that are either partially or totally unpublished, or are only available from a single vendor for a substantial fee, and/or under restrictive terms, thus making the implementation and use by third parties of products that conform to the given specifications subject to control.”</p>
Justification	High-level list C
Domestic/Non-domestic	D/ND
Use Case(s)	Non Functional
Normative Reference(s)	European Interoperability Framework v2
Data Item Reference(s)	This requirement relates to protocols and formats for transferring data rather than the data being stored by the system itself.
Security Requirement(s)	Security Requirements document
Component(s) affected	Electricity Meter, gas meter, IHD, Communications Hub

Prospectus Requirement	The WAN interface shall support interrogation of WAN enabled devices in line with agreed DCC service levels.
ID	WA.2
Extended	WA.2.1 The WAN interface shall allow for communication to be initiated from the DCC to allow for communication with Smart Metering System components

Requirement	<p>in the premises including meters, the Communications Hub, and any associated WAN module.</p> <p>WA.2.2 – Where the WAN technology supported by the WAN interface is not ‘always on’, then the WAN interface shall be capable of:</p> <p>Receiving an incoming request for connection, and</p> <p>Initiating a call set-up to establish the connection.</p> <p>WA.2.3 – Where call set-up is required, the call set-up time for the WAN interface shall be in accordance with agreed service targets.</p> <p>WA.2.4 – The WAN interface shall support interrogation of the Smart Metering System by an Authorised Party to confirm that it is on supply and has a WAN signal.</p>
Extended Narrative	An example of interrogation of connected devices could be a “ping” to check whether it is on supply and has active communications.
Justification	High-level list A
Domestic/Non-domestic	D/ND
Use Case(s)	UC 10.01 – Check status and settings of a SMS component
Normative Reference(s)	Refer to Application Layer standards in Normative References Refer to SM-CG table of WAN standards in Normative References
Data Item Reference(s)	N/A
Security Requirement(s)	SP.30, SP.31, SP.32, SP.33, SP.34, SP.35, SP.36, SP.37, SP.301, SP.302, SP.303
Component(s) affected	All

Prospectus Requirement	The WAN interface shall support acknowledge signals
ID	WA.03
Extended Requirement	<p>WA.3.1 The WAN interface shall support outbound communication to allow acknowledgements and other outbound messages initiated from the Smart Metering System components in the premises.</p> <p>WA.3.2 The WAN interface shall support the necessary WAN protocol layer acknowledgements at network and data link layers as appropriate, to ensure effective communication with the WAN service.</p>
Extended Narrative	This is to, for example, test the integrity of the WAN connection to the Smart Metering equipment within the premises
Justification	High level list A
Domestic/Non-domestic	D/ND
Use Case(s)	N/A
Normative Reference(s)	WAN Interfaces will use WAN Solutions Standards as referred by the Normative References WAN Communications Table

Data Item Reference(s)	Network Data, in particular: Read Acknowledgement Flag (for incoming messages)
Security Requirement(s)	SP.30, SP.31, SP.32, SP.33, SP.34, SP.35, SP.36, SP.37, SP.301, SP.302, SP.303
Component(s) affected	All

Prospectus Requirement	The WAN interface shall be certified and tested for interoperability.
ID	WA.4
Extended Requirement	WA.4 SMS Components utilising a WAN shall be certified as being interoperable via the relevant certification processes set out in the Interoperability Principles document. WA.4.1 SMS Components utilising a WAN shall be certified as 'fit for purpose' in accordance with the test regime to be prescribed in the Smart Energy Code.
Extended Narrative	All SMS Devices which require to be connected to the WAN shall include certification to the WAN Protocol(s) or standard(s) used. Depending on the overall governance of the technical specification, and the individual technology standard, this shall include tests for interoperability of devices from different manufacturers, or Type Approval activities.
Justification	High level list A
Domestic/Non-domestic	D/ND
Use Case(s)	N/A
Normative Reference(s)	IEC 17011, IEC 17025, IEC 17043
Data Item Reference(s)	This requirement relates to testing data integrity rather than data content.
Security Requirement(s)	Not applicable
Component(s) affected	No SMS Components within the scope of Interoperability Testing Working Group (IOTWG) except when interfaced with a WAN Interface ,i.e. potentially gas meter and/or Electricity Meter with integral Communications Hub.

Prospectus Requirement	The WAN shall support the security and privacy requirements
ID	WA.5
Extended Requirement	
Extended Narrative	Original requirement is sufficient
Justification	High-level list A

Domestic/Non-domestic	D/ND
Use Case(s)	N/A
Normative Reference(s)	N/A
Data Item Reference(s)	N/A
Security Requirement(s)	N/A
Component(s) affected	N/A

Prospectus Requirement	The WAN interface shall be capable of being disabled and re-enabled by authorised personnel.
ID	WA.06
Extended Requirement	This requirement is no longer relevant and has been removed.
Extended Narrative	
Justification	High-level list A
Domestic/Non-domestic	D/ND
Use Case(s)	N/A
Normative Reference(s)	N/A
Data Item Reference(s)	N/A
Security Requirement(s)	N/A
Component(s) affected	N/A

1.106. Smart Metering equipment, including the WAN modules, will be required to operate in compliance with guidelines published by The International Commission on Non-Ionizing Radiation Protection (ICNIRP). It is also an independent scientific organisation with responsibility in this area. The ICNIRP guidelines cover limiting human exposure to Electromagnetic fields (EMF).

IHD Requirements

1.107. The IHD requirements apply to any IHD that is provided to the consumer as the result of an obligation. They are necessarily high level (to avoid restricting innovation) and cover the minimum information provision as well as power requirements.

Prospectus Requirement	The IHD shall support mains power operation.
ID	IH.1
Extended Requirement	<p>IH.1 The minimum specification IHD shall support direct mains power operation with a nominal input of 230V, or indirectly from a suitable power supply.</p> <p>IH.1.1 The IHD shall display a power-up sequence on connection to the mains.</p> <p>IH.1.2 The power-up display sequence shall comprise an indication of the SM HAN connection status, and either null values or a holding message to ensure the consumer receives feedback that information is being updated, until up-to-date data is received over the SM HAN.</p> <p>IH.1.3 The IHD shall meet the requirements of DI.4.</p> <p>IH.1.4 The IHD shall always display information (null values if no data is available over the SM HAN) whilst power is applied, (i.e. there is no need for the consumer to have to interact at the wake up of the device in order for information to be presented).</p>
Extended Narrative	There is no requirement to have a battery in the minimum specification IHD.
Justification	High level list C
Domestic/Non-domestic	D
Use Case(s)	N/A
Normative Reference(s)	<p>BS1363</p> <p>Electrical equipment (safety) regulations 1994</p> <p>Electromagnetic compatibility regulations 1992</p> <p>BS EN 60950-1 Information technology equipment – Safety Part1</p> <p>IP rated appropriate for in-home operational environment in accordance with BS EN 60529</p> <p>CE mark</p> <p>R&TTE Directive (if the IHD has a radio)</p> <p>WEEE ROMS Regulations/Directive</p> <p>Low Voltage Directive 2006/95/EC</p>
Data Item Reference(s)	This relates to physical rather than data requirements
Security Requirement(s)	N/A
Component(s) affected	IHD

Prospectus Requirement	<p>The IHD shall show the following information for gas and electricity:⁴</p> <ul style="list-style-type: none"> • Indicative real-time usage in kW • Indicative real-time rate of consumption in pence per hour • Electricity - Metered cumulative consumption in kWh and indicative £ for current day/week/month/billing period • Gas - Metered cumulative consumption in m³, Indicative (within CV variance) cumulative consumption in kWh and £ for current day/week/month/billing period • A high-level requirement that historical data should be presented in a meaningful way so as to allow a consumer to compare current usage with past usage • Account balance information (amount in credit or debit) in real time for prepayment customers and on at least a monthly basis for credit customers • Current and next tariff rate (i.e. cost per unit in pence per kWh) • Local time • Status of communication link. <p>All information will be displayed in digital numerical format as a minimum. In addition, information on real-time energy rate (kilowatt) and cost of current level of consumption (pence per hour) will, as a minimum, be displayed in a visual (non numerical) way which allows a consumer to easily distinguish between low and high current consumption. Guidelines for "ambient" feedback will be developed by the programme as part of the technical specification process.</p> <p>Aspiration for real time update for electricity is 5 seconds, for gas it is 30 minutes.</p>
ID	IH.2
Extended Requirement	<p>IH.2.1.1 Provided the minimum specified functional requirements shall be met by the IHD, and the non-functional features of the IHD are fit for the operational environment and purpose, there is no prescription in the design of the device.</p> <p>IH.2.1.2 Nothing herein is intended to preclude innovation incorporated in the form and function of an Enhanced IHD.</p> <p>IH.2.1.3 All requirements, with exception of functions IH.2.2, IH.2.3 and IH.2.4, which are applicable for electricity only, shall relate to both gas and electricity and be active in operation where electricity and/or gas metering is a component part of the Smart Metering System commissioned on the Smart Metering In-Home Network (SM HAN) irrespective of whether the same Supplier is the providing party for both fuels.</p> <p>IH.2.1.4 Where calculated values are required, these calculations shall be undertaken and stored in other SMS components and the results transmitted to the IHD at appropriate frequencies.</p> <p>IH.2.1.5 It is required that the IHD shall be able to receive and refresh</p>

⁴ Some of these requirements have been removed after careful consideration of recommendations brought forward by the IHD working group. These are Account balance for credit customers; Ambient display of real-time energy based on cost; Real time gas demand; Consumption and cost in latest bill period; and Next Tariff Rate.

information on the display at better than 10s intervals.

IH.2.1.6 The minimum specification IHD shall:

- Adhere to all recommendations as defined in the security and data privacy requirements.
- Present date and time information in local time as provided via the SM HAN (defined in DS.5).
- Reflect indicative costs related to consumption displayed utilising the Indicative Price Per Unit.
- Retain data covering cumulative historical energy consumption and cost of consumption corresponding to the previous eight days, the previous five weeks and the previous thirteen months on a rolling basis in non-volatile memory i.e. twenty six historical data items held per fuel type.
- Provide for option to display currency in GBP (£p) or Euro (€c)(defined in DS.1).
- Provide for option, either incorporated in a single device or through variant, to display in English or Welsh language (defined in DS.8).
- Display null values on screen whenever active communications with the SM HAN is not engaged. (Note - a null state shall be displayed, for instance, as a hyphen rather than a zero value.)
- Facilitate the erasure of locally stored data (Defined in DS.6).
- In instances where the IHD is powered down or out of SM HAN range at the time of an erase data command being instigated, the Smart Metering System shall send a rejection message to the issuer of any command that fails validation and authentication. (Defined in DS.6.6).
- Upon power up, provided it is paired to the SM HAN, the IHD shall request & receive a full refresh of historical data items (e.g. data items covering the full set of historical whole day, whole week and whole month consumption and cost of consumption). The number of data items received shall be dependent on the duration the Smart Meter(s) has been in-situ and on the data available within the Smart Metering System.
- Where the IHD experiences intermittent SM HAN connection, upon reconnection it shall request & receive a full refresh of historical data items (e.g. data items covering the full set of historical whole day, whole week and whole month consumption and cost of consumption). The number of data items received shall be dependent on the last time the IHD was connected to the SM HAN and the last data items received.
- The minimum requirements specification principally outlines the IHD as a device that shall receive information (i.e. read-only).
- The IHD shall be able to be paired to the SM HAN (defined in HA.2).
- The IHD shall be able to store all required data and configuration information in Non-volatile memory.
- Have the capability to revert to a 'home or default' view after a set period of inactivity.
- Display indication of what payment mode the account for gas and electricity is operating under) i.e. either Credit or Pre-Payment).

IH.2.2 The IHD shall display real-time electricity power demand in kW

IH.2.2.1 The minimum specification IHD shall:

- Numerically display, in kW or watts, the instantaneous level of imported electricity demand output by the electricity meter which is commissioned to the same SM HAN as that of the IHD.
- Hold the information related to the instantaneous electricity demand value for the period between updates provided that the IHD remains powered up for the duration.

	<ul style="list-style-type: none"> • Revert the display of instantaneous power demand to that of a null value (e.g. --. kW) where no update is received over the SM HAN covering a continuous period of 60 seconds. <p>IH.2.3 The IHD shall display ambient (non-numeric) visualisation of instantaneous electricity demand</p> <p>IH.2.3.1 The minimum specification IHD shall:</p> <ul style="list-style-type: none"> • Display an ambient (non-numeric) visualisation of instantaneous electricity demand as facilitated by the corresponding High, Medium or Low indication received from the Smart Meter via the SM HAN alongside the power value as per IH.2.2.1. • Retain display of ambient feedback between updates unless no update is received for 60 seconds whereby it shall provide no feedback. <p>IH.2.4 The IHD shall display instantaneous electricity demand shown as a cost equivalent in £p (or €c)</p> <p>IH.2.4.1 The minimum specification IHD shall:</p> <ul style="list-style-type: none"> • Display the indicative cost associated with the instantaneous level of electricity demand in £p/h (or €c/h) corresponding to the instantaneous electricity demand received via the SM HAN alongside the power value received as per IH.2.2.1. • Hold the information related to the indicative cost for the period between data refresh updates provided that the IHD remains powered up for the duration. • Revert the display of indicative cost to that of a null value (e.g. £---) where no update is received over the SM HAN covering a continuous period of 60 seconds. <p>IH.2.5 The IHD shall display current tariff rates for gas and electricity in pence per kWh (or cents per kWh)</p> <p>IH.2.5.1 The minimum specification IHD shall:</p> <ul style="list-style-type: none"> • Display current import tariff rate in £p/kWh. • Where two rates operate concurrently (e.g. twin element electricity meter variant), the display shall show a totalised value of the active rates, where appropriate and possible. • Upon power up and 'pairing' or connection to the SM HAN the IHD shall receive prevailing tariff related information. • Display null values until tariff related information is received after power up. • Once beyond the power up sequence, receive a refresh of current active tariff rates whenever a rate change has occurred e.g. on ToU rate switchover. • Hold the information related to the tariff for the period between updates provided that the IHD remains powered up. <p>IH.2.6 The IHD shall display cumulative consumption – current day, week and month in kWh and in £p (or €c) for Electricity and Gas</p> <p>IH.2.6.1 The minimum specification IHD shall:</p> <ul style="list-style-type: none"> • Display cumulative gas and electricity consumption for the current day, current week and current month in kWh. • Display indicative cost associated with cumulative consumption for current day, current week and current month in £p (or €c). • Display cumulative consumption related information in the same way regardless of meter mode of operation (i.e. Credit or Pre-Payment). • Once beyond the power up sequence receive current day, current week and current month related information at 30 minute or better intervals. • Hold the information related to cumulative consumption for the period between updates provided that the IHD remains powered up. • Revert the display of cumulative consumption information to that of null
--	--

	<p>values where no update is received over the SM HAN covering a continuous period of 120 minutes.</p> <p>IH.2.7 The IHD shall display a comparison of current usage with past usage for electricity and gas in £ (or €) and kWh</p> <p>IH.2.7.1 The minimum specification IHD shall have access to the following data sets via the SM HAN, in order to provide consumers with a historical consumption comparison of energy use within their household:</p> <p>IH.2.7.1.1 Day Comparison. The current Day (DC0) commences 00:00:00 hrs until 23:59:59 hrs on the current day In local (BST) time:</p> <ul style="list-style-type: none"> • DC-0 = Current days consumption in kWh & £p (or €c) including the time of the last update compared against • DC-1 = Current day minus 1 • DC-2 = Current day minus 2 • DC-3 = Current day minus 3 • DC-4 = Current day minus 4 • DC-5 = Current day minus 5 • DC-6 = Current day minus 6 • DC-7 = Current day minus 7 • DC-8 = Current day minus 8 <p>IH.2.7.1.2 Week Comparison. The current week (WC0) commences 00:00:00 Hrs Monday till 23:59:59 hrs Sunday in local (BST) time:</p> <ul style="list-style-type: none"> • WC-0 = Current week consumption in kWh & £p (or €c) including the date and time of the last update compared against • WC-1 = Current week minus 1 • WC-2 = Current week minus 2 • WC-3 = Current week minus 3 • WC-4 = Current week minus 4 • WC-5 = Current week minus 5 <p>IH.2.7.1.3 Month Comparison. The current month (MC0) commences at 00:00:00 on the 1st calendar day and finishes at 23:59:59 on the last calendar day of the month:</p> <ul style="list-style-type: none"> • MC-0 = Current months consumption in kWh & £p (or €c) - also date and time of the last update compared against • MC-1 = Current month minus 1 • MC-2 = Current month minus 2 • MC-3 = Current month minus 3 • MC-4 = Current month minus 4 • MC-5 = Current month minus 5 • MC-6 = Current month minus 6 • MC-7 = Current month minus 7 • MC-8 = Current month minus 8 • MC-9 = Current month minus 9 • MC-10 = Current month minus 10 • MC-11 = Current month minus 11 • MC-12 = Current month minus 12 • MC-13 = Current month minus 13 <p>IH.2.7.2 Once beyond the power up sequence receive information on current day, week and month at 30 minute or better intervals.</p> <p>IH.2.7.3 Receive a refresh of the previous eight whole day rolling data set daily, immediately after midnight (local time).</p> <p>IH.2.7.4 Receive a refresh of the previous five whole week rolling data set weekly, immediately after midnight (local time) every Sunday.</p>
--	--

IH.2.7.5 Receive a refresh of the previous thirteen whole month rolling data set monthly, immediately after midnight (local time) on the final day of each calendar month.

IH.2.7.6 Hold the information related to comparison of usage for the period between updates provided that the IHD remains powered up.

IH.2.7.9 Revert the display current and past usage comparison information to that of null values where no update is received over the SM HAN covering a continuous period of 120 minutes.

IH.2.8 The IHD shall display the account balance for electricity and gas. This will only be applicable for pre-payment mode of operation, the minimum specification IHD shall:

- Display the account balance, whether it be positive or negative, in £p (or €c).
- Display the date in DD/MM and time in 24Hr:mm in local time associated with the latest account balance update.
- Display a warning indication whenever the account balance state falls below that of the low balance threshold.
- Display indication whenever the emergency credit option has been invoked by the consumer on the gas and / or electricity meter.
- Once beyond the power up sequence receive information at 10 second intervals or better for electricity and 30 minute intervals or better for gas.
- Hold on display the most recently updated account balance information for the period between updates provided that the IHD remains powered up.
- Revert the display of account balance information to that of null values where no update is received over the SM HAN covering a continuous period of 5 minutes for electricity and 120 minutes for gas.

IH.2.9 The IHD shall display ancillary information for electricity and gas when in pre-payment mode. This is applicable for pre-payment mode of operation only, the minimum specification IHD shall:

- Display the aggregated total debt amount balance in £p (or €c).
- Display the aggregated debt recovery amount in £p (€c) / day, £p (€c) / week where applicable. Note that the recovery frequency (per day, per week) is a parameter set as part of the meter configuration on set up of the pre-payment arrangement and shall therefore be a data item for the IHD made available over the SM HAN.
- Once beyond the power up sequence the IHD shall receive information on total debt balance and recovery rate as configured in SMS, set up by the Supplier.
- Hold the information related to the pre-payment account debt related information for the period between updates provided that the IHD remains powered up.
- Revert the display of debt related information to that of null values where no update is received over the SM HAN covering a continuous period of 3 days.

IH.2.10 The IHD shall display the status of the HAN communication link.

IH.2.10.1 The minimum specification IHD shall:

- Display on power up an indication in instances where the IHD has not been commissioned to the incumbent SM HAN and is therefore inoperative until successful on-site commissioning is complete.
- Show an indication of low SM HAN signal strength in instances where the communication path between the communications Hub and the IHD is too weak for data transmission. This indication may apply at any point in time when the IHD is powered up and shall only clear once communications are restored.
- Provide a visual warning when not receiving information at expected

	intervals irrespective of SM HAN signal status.
Extended Narrative	
Justification	High-level list C
Domestic/Non-domestic	D
Use Case(s)	UC.03 UC.19
Normative Reference(s)	<p>Note that the communications standards are to be applied as appropriate in relation to the type of HAN deployed. The following list is not necessarily exhaustive.</p> <p>ISO 13407 and ISO 9241-11 related to usability BS EN 60950-1 Information technology equipment – Safety Part1 CE conformance Rohs Directive WEEE Directive EuP Directive Low Voltage Directive BS EN 61000-4-2 BS EN 61000-4-3 BS EN 61000-4-4 BS EN 61000-4-6 BS EN 61000-4-8 BS EN 61000-4-9 BS EN 55022 EN 300 328 EN 301 511 (GSM) EN 301 489-01 EN 301 489-07 EN 301 489-17 EN 301 489-24 (IMT -2000 CDMA direct spread radio (3G)) EN 301 908-01 (3G GPRS) EN 301 908-02 (3G GPRS) BS EN 50360 BS EN 50371 1999/519/EC</p>
Data Item Reference(s)	<p>Data Items:</p> <p>Account Balance Activity Type, Activity DateTime Activity Type, Activity DateTime (where activity type defines supply outage end) Activity Type, Activity DateTime (where activity type defines supply outage start) Block Element Name Calorific value Cumulative Consumption in Period Cost Cumulative Consumption Period Cumulative Consumption in Period Cumulative Consumption Period Currency Customer Start Date</p>

	Debt Recovery Frequency Debt Recovery Rate Debt Value Device Id Emergency Credit Status Instantaneous Power Cost Language Local Time Measurement Quantity Measurement Quantity Description Measurement Quantity Id Meter Mode Meter Register Meter Register Description Meter Register ID Meter Register Id, Measurement Quantity Meter Register Id, Meter Register Name Meter Register Name Power Threshold Status Price per Unit PTZ conversion factor Random Offset Random Offset Enabled Random Offset Scalar Reading Date & Time Supply Status Switching Period Id, Switching Time Off Switching Period Id, Switching Time On Tariff Indicator Tariff Rate Threshold Type Time Band Name
Security Requirement(s)	SP.1, SP.7, SP.8, SP.10, SP.11, SP.12, SP.13, SP.14, SP.16, SP.17, SP.29, SP.55
Component(s) affected	IHD

Prospectus Requirement	The average IHD power consumption shall be less than 0.6W.
ID	IH.3
Extended Requirement	IH.3 The IHD demand averaged over a 24-hour period shall be less than 0.6W.
Extended Narrative	The average demand of the minimum specification IHD is based on 24 hours of steady state consumption with one user-interaction event, lasting less than one minute. When responding to an event, the IHD may temporarily operate at a higher power consumption to facilitate modes of user interaction as per IH.2.
Justification	High-level list C and impact assessment
Domestic/Non-domestic	D

Use Case(s)	N/A
Normative Reference(s)	BS1363 Electrical equipment (safety) regulations 1994 Electromagnetic compatibility regulations 1992 BS EN 60950-1 Information technology equipment – Safety Part1 IP rated appropriate for in-home operational environment in accordance with BS EN 60529 CE mark R&TTE Directive (if the IHD has a radio) WEEE ROM Regulations/Directive Low Voltage Directive 2006/95/EC
Data Item Reference(s)	This relates to physical rather than data requirements
Security Requirement(s)	N/A
Component(s) affected	IHD

Security

Introduction and Approach

1.108. This appendix presents the approach that the Smart Metering Implementation Programme (referred to as the Programme) has followed for developing the security requirements of the End-to-end Smart Metering System.

1.109. The Prospectus document, published in July 2010, presented a Statement of Design Requirements that included a number of high level Security Requirements along with a number of requirements for device and system functionality. The Prospectus also set out the Programme's intention to implement a risk based, informed approach to Security.

1.110. The Programme has built upon these initial requirements by carrying out detailed security risk assessments through consultation with industry and other government departments. The security risks identified in this process have been used to develop the security principles and a more detailed set of security requirements covering both technical and organisational security areas.

1.111. To support the informed approach to security, ongoing consultation has been achieved through the creation of a steering group of security technical experts combining representatives from Industry, Government and the Programme. This group of experts is referred to as the Security Technical Experts Group (STEG).

1.112. The security requirements in this document are a subset of a wider set of security requirements that cover the end-to-end Smart Metering system.

Consultation

1.113. The Programme has not developed the security requirements in isolation – in order to provide as full a range of stakeholder views as possible the Programme security experts have consulted with a wide range of security subject matter experts from Industry and Government.

1.114. Consultation has taken place through the Security Technical Experts Group (STEG), This group has provided expertise and information, as well as oversight, supporting the development of the security risk assessment and the security requirements for mitigating the identified risks.

Security and Technical Experts Group (STEG)

1.115. The overall objective of the group is to inform the Programme in the area of security by:

- Actively identifying and supporting the assessment of security risks and threats across the Smart Metering design.
- Providing advice on the governance of identified security risks, and the risk mitigation strategies for the design, implementation and operation of systems proposed by the Programme.
- Providing a forum where security matters can be discussed and advice can be provided on mitigating security risks and threats identified.
- Helping the Programme to understand the impact of security issues on the End-to-end Smart Metering System and stakeholder organisations.
- Sharing information on EU security forums and working groups to ensure the Programme is aware and aligned with European initiatives.

1.116. To facilitate the work of the Programme, two STEG sub-groups were created from within its membership. These covered the following areas:

- Security risk assessment: support the Programme in identifying and quantifying security risks.
- Security Requirements: review and assess the security requirements at the different stages of development, providing subject matter expertise and challenge to the Programme.

1.117. During the design work carried out by the SMDG sub-groups STEG also provided a number of members to act as a “Security Representative” for each sub-group providing security focussed challenge and advice.

Smart Metering Security Risk Assessment

1.118. The Smart Metering security risk assessment uses Her Majesty's Government Information Assurance Standard One (HMG IS1)⁵ as the technical security risk assessment methodology. The security risk assessment process identified threats that could affect the end-to-end Smart Metering System and assessed their likelihood of occurrence and their potential impact on the system.

1.119. In determining the threats and likelihood of their occurrence, the Programme consulted with experts within the STEG risk assessment sub-group as well as directly with the following groups:

- CPNI (Centre for Protection of National Infrastructure)
- SOCA (Serious Organised Crime Agency)
- CESG (the national technical authority for information assurance).

1.120. The threats to the Smart Metering System as a new nationwide system of complex components are numerous, especially as the system will form a part of Great Britain's Critical National Infrastructure.

1.121. In summary the threats to Smart Metering fall into several broad categories:

- Cyber Threats – These include hackers, malicious software and electronic warfare threats
- Insider Threats – This includes deliberate and accidental threats to systems from its own users and those with authorised access
- Criminal Threats – Threats motivated by criminal gain or fraud.

1.122. The risk level of all threats identified has been assessed in terms of impact to the end-to-end Smart Metering system. While some of the threats may have a major impact for a single consumer it must be noted that these will not affect all Smart Meter installations and therefore, in the context of the end-to-end Smart Metering System risk assessment will have a low associated level.

1.123. When carrying out the risk assessment no security controls are assumed to be in place. This allows the assessment to capture a clear picture of the threats and inherent risk that needs to be mitigated.

Security Risk Assessment Scope

1.124. The security risk assessment scope covers the end-to-end Smart Metering system from the customer premise to the DCC Users Smart Metering Systems (as shown in Figure 27).

⁵ HMG IA Standard no. 1 - Part 1, 2009, CESG and Cabinet Office

Figure 27 – Risk Assessment Scope

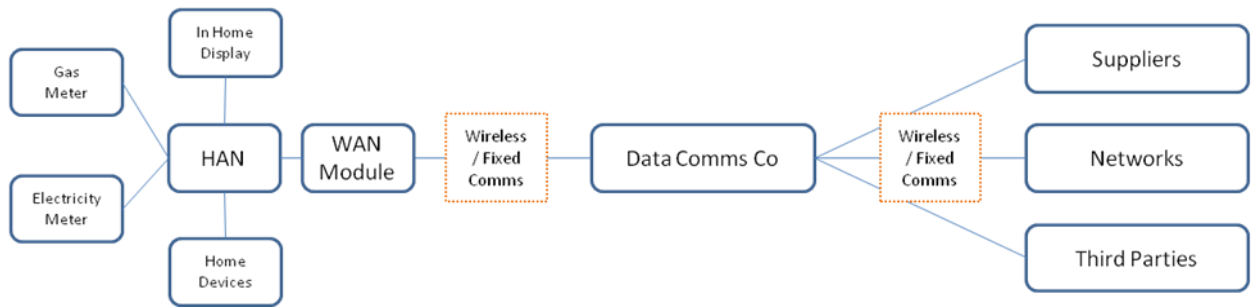

Risk Areas

1.125. The security risk assessment produced detailed set of security risks that could affect the end-to-end system. It is important that the security requirements presented in the ESoDR are understood in the context of these risks.

1.126. The risks summarised here are based on an assessment of the risks to the entire end-to-end system, not just the equipment specified by the ESoDR.

1.127. The most prominent area of risk, which has the highest impact and likelihood, is the DCC and the Wide Area Network connections that will form a widespread part of the end-to-end Smart Metering System.

1.128. The DCC forms a core section of the Smart Metering infrastructure, providing connections to each of the 28 million homes that will have equipment installed. The DCC as an organisation will rely on its service providers and equipment manufacturers as well as its own personnel to supply and manage its infrastructure and operations.

1.129. Access and control functionality of this nature presents risks such as insider threats from personnel with privileged access to critical data and equipment. A compromise of security at the DCC could have a large scale impact on a large number of premises.

1.130. Events in the past year have shown that “Cyber” threats to the Energy industry are becoming more prevalent. The DCC is likely to be directly or indirectly targeted by IT based threats such as viruses, hacking or other technical attacks.

1.131. Installation of equipment into customer premises will provide a common level of access to WAN connections decreasing many of the traditional barriers that may indirectly prevent an unsophisticated threat actor from attacking the system.

1.132. Additionally, Smart Metering devices installed in the customer premises are vulnerable to physical security threats, including tampering and disruption. The Home Area Network functionality, whether based on wired or wireless technologies could also be used as an avenue for misuse.

1.133. Overall the equipment installed into the customer premises needs to provide a robust set of controls to protect against loss of personal data, to verify the integrity of commands and instruction from the DCC and to prevent unauthorised access to the wider Smart Metering system via the WAN connectivity they provide.

Security Requirements Development

1.134. The security requirements included in the ESoDR and across the wider Programme are based on the results of the Smart Metering Risk Assessment produced by the Programme with the aim of treating the security risks identified in a proportionate manner.

1.135. Figure 28 below outlines the Programme’s approach to the development of the security requirements.

Figure 28 – Security Requirements development approach

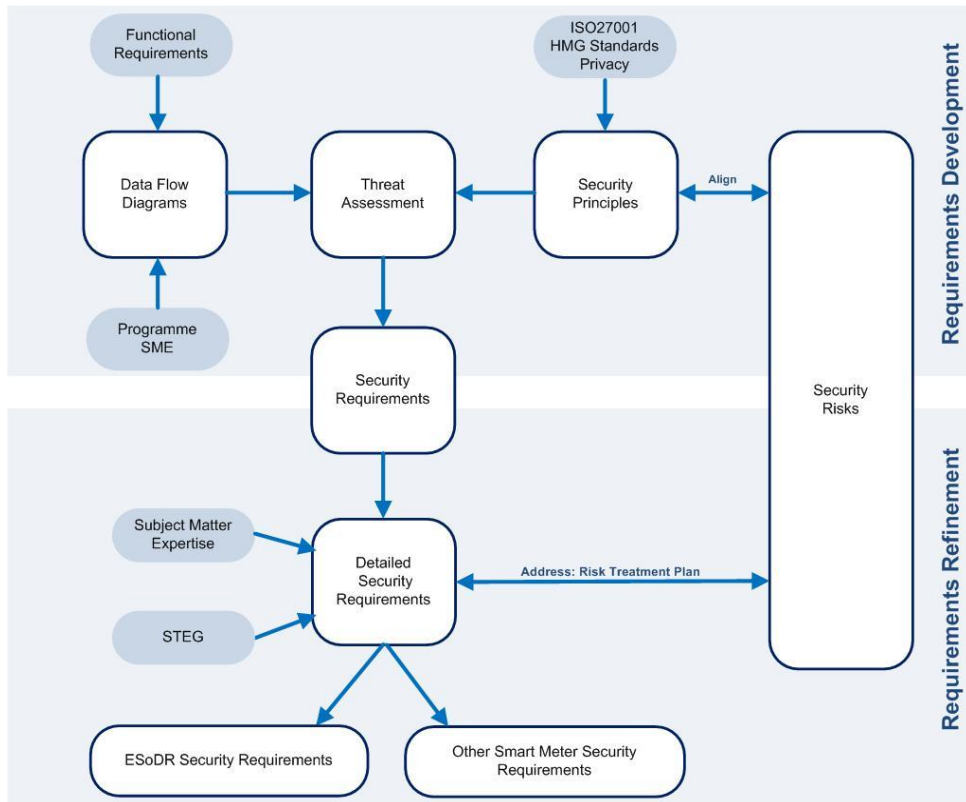

Data Flow Diagrams

1.136. The functional and technical requirements developed by the Programme, and first presented in the Prospectus documents, were used to define a set of data flow diagrams detailing the proposed architectural of the end-to-end Smart Metering System.

1.137. The data flow diagrams represent a model of the relationships between the main assets and data flows within the End-to-end Smart Metering System. These diagrams present a formal view of the system and its likely construction forming the basis for the application of the security principles throughout the threat assessment process.

Security Principles

1.138. A set of overarching security principles were identified by the Programme based on the control set defined in ISO/IEC 27001:2005. These categories of security controls are an accepted standard for industry good practice.

1.139. The principles provide a view of the technical, personnel and process controls that could be applied to mitigate an identified set of risks. It is not however, appropriate to apply the full set of controls to every risk.

Threat Assessment

1.140. Using a structured threat assessment process allows each of the risks to be applied to the proposed system in terms of the threat to confidentiality, integrity and availability it poses. To implement this the assessment

approach expands the key security properties of Confidentiality, Integrity and Availability to better reflect the likely categories of threat to these properties. The expanded threat categories are:

- Spoofing,
- Tampering,
- Repudiation,
- Information Disclosure,
- Denial of Service,
- Elevation of Privilege.

Security Requirements

1.141. The threat assessment process matched the defined security principles to specific data flows and assets and drove the creation of the initial security requirements. These initial security requirements covered the End-to-end Smart Metering System including:

- Equipment design requirements (Smart Meters, Communications Hub, Handheld Devices etc),
- DCC requirements,
- Wide Area Network requirements,
- Governance and Accreditation requirements.

1.142. The initial security requirements were further developed and refined with input from the STEG Requirements sub-group.

Detailed Security Requirements

1.143. Following the development of the initial security requirements the Programme facilitated continuous review and refinement of the security requirements by the STEG Requirements sub-group and consultation with wider Programme stakeholders.

1.144. The detailed security requirements have also been consulted upon with a wider set of stakeholders. This includes members of the:

- Smart Meter Design Group (SMDG)
- DCC Design Group (DCCG)
- Business Process Design Group (BPDG)
- Wide Area Network Subject Matter Experts.

1.145. Other stakeholders included:

- Energy Suppliers,
- Network Operators,
- Code Administrators and Market Entry assessment organisations e.g. Elexon, Gemserv,
- Industry Associations such as the Energy Retail Association, Association of Meter Operators.

1.146. Overall the detailed requirements form part of a wider process to treat security risk within the system. The Risk Treatment Plan that has been produced by the Programme links all security requirements back to specific categories of identified risk allowing the overall state of risk mitigation in the end-to-end system to be ascertained.

1.147. The requirements are designed to be proportionate to the risks identified, taking into account stakeholder information and expertise around cost, technological feasibility and industry good practice.

ESoDR Security Requirements

1.148. The detailed security requirements cover technical design, governance, DCC and Wide Area Network (WAN) security requirements. Not all of these requirements are suitable for the ESoDR as they do not directly support the development of equipment in the customer premises.

1.149. The requirements presented in this document are only those that have a functional or technical impact on the design and implementation of customer premises Smart Metering devices. It should be noted that they are not intended to mitigate every risk in the end-to-end system and require the support of the wider requirements set (e.g. many security risks are partially addressed by monitoring controls within the DCC and/or its Users).

Security assumptions

1.150. To define the Security Requirements, several assumptions have been made. These are:

- Communications functionality may be implemented in different physical and logical components. For example, WAN functionality could conceivably be implemented in the Communications Hub or in the Smart Meter itself,
- SM HAN functionality may be implemented using both wired and wireless technologies; this is because the latter may not be suitable for all consumers and types of consumer premises,
- Core Devices will communicate with each other only via the SM HAN,
- Consumer devices will connect to the SM HAN only through an Interface or Bridging Device,
- WAN functionality is unlikely to be based on a single technology. Several technologies may be needed to ensure that there is complete communications coverage for all locations and types of premises,
- The gas Smart Meter will not be available with a mains power supply (for safety reasons) and will be battery-powered, as defined in the functional requirements for gas Smart Meters,
- The Core Devices described will meet the functional requirements specified by the Programme.

Security Requirements

1.151. The security requirements set out in this section are the minimum requirements that need to be met (additional controls may be implemented over and above what is specified) and are presented in a tabular format as show below.

Requirement	The requirement text.
ID	The unique identifier for the requirement.
Narrative	An explanation of the requirement, its context and/or example implementations.

1.152. The narrative aims to provide context and additional information supporting the requirement in order for it to be accessible to non-security professionals. In addition, examples that satisfy the requirement may be presented. It should be noted that these are only examples and are not intended to be restrictive in terms of implementation of a solution to meet a requirement.

1.153. The requirements apply to:

- All devices (Overarching Requirements)
- Smart Meters
- Base Functionality IHDs
- Communications Hub
- Handheld Devices
- Pre-Payment Functionality.

Overarching requirements

1.154. These requirements apply to all Core Devices in the Smart Metering System:

Requirement	Non-security functionality on Core Devices and Systems, if compromised, shall not affect the overall device or system security functionality.
ID	SP.1
Narrative	<p>A vulnerability or a fault in a non-security firmware or software module can potentially impact security functionality and result in compromise of Smart Metering devices and systems.</p> <p>A secure implementation of Core Devices and Systems must ensure that:</p> <ul style="list-style-type: none"> • Compromise of non-security functionality does not affect the security functionality of a device • Security functionality is not reliant on other non-security functions. <p>For example, a secure implementation of Core Devices and Systems may include physical or logical separation of security and non-security functionality.</p> <p>Separation can be implemented either physically in hardware or logically in software, e.g. the metrology module that takes measurements on Smart Meters should be separate from security functionality that protects the integrity of the resulting measurement data.</p>

Requirement	Any cryptographic algorithm that is relied upon for the security of the End-to-end Smart Metering System shall be FIPS (or equivalent) approved.
ID	SP.2
Narrative	<p>Weak cryptographic ciphers, insecure implementations or proprietary algorithms that have not undergone independent security reviews may lead to a system compromise and unauthorised access to Sensitive Data.</p> <p>A cryptographic algorithm is considered 'relied upon' if it is the only means by which confidentiality, integrity or authenticity is verified or assured.</p> <p>The NIST 'Cryptographic Algorithm Validation Program' (CAVP) provides a list of FIPS-approved and NIST-recommended cryptographic algorithms that should be used in Smart Metering implementations. Other standards that provide a testing mechanism for cryptographic algorithms may be published in the future. In this case, approved lists of cryptographic algorithms that are equivalent to the FIPS-approved algorithms may also be used.</p> <p>Equivalence will be demonstrated by an algorithm passing the Cryptographic tests included in the CESG Consumer Product Assurance Handbook. <i>[This is currently</i></p>

	<i>awaiting publication]</i>
--	------------------------------

Requirement	Any random number generation algorithm for cryptographic key generation that is relied upon for the security of the End-to-end Smart Metering System shall be FIPS (or equivalent) approved.
ID	SP.3
Narrative	<p>Random number generator algorithms are used in the generation of cryptographic keys. Algorithms with low levels of entropy or predictable output can compromise the security of cryptographic algorithms and keys.</p> <p>The NIST ‘Cryptographic Algorithm Validation Program’ (CAVP) provides a list of Federal Information Processing Standard (FIPS) approved and NIST recommended random number generation algorithms that should be used in Smart Metering implementations.</p> <p>Equivalence will be demonstrated by an algorithm passing the Cryptographic tests included in the CESG Consumer Product Assurance Handbook. <i>[This is currently awaiting publication]</i></p>

Requirement	<p>Any Cryptographic Module used within the End-to-end Smart Metering System shall be compliant to:</p> <ul style="list-style-type: none"> • FIPS140-2 Level 2 excluding the ‘Operational Environment’ requirement • FIPS140-2 Level 1 for the ‘Operational Environment’ requirement.
ID	SP.4
Narrative	<p>The Federal Information Processing Standard 140-2 provides a standard for the assurance for Cryptographic modules.</p> <p>FIPS 140-2 Level 2 requires the Cryptographic Module to be tamper-evident through the use of tamper-evident coatings or seals. Any Cryptographic Module conforming to the FIPS140-2 Level 2 must meet the requirements in all areas except for the ‘Operational Environment’ requirement.</p> <p>Instead, specifically for the Operational Environment requirement, any Cryptographic Module must meet at least FIPS140-2 Level 1.</p> <p>Compliance in the context of this requirement requires technical assurance that any Cryptographic Module meets the relevant FIPS140-2 Level 1/2 requirements.</p>

Requirement	Compromise of any cryptographic material within a Core Device shall not have a Material Impact on the End-to-end Smart Metering System.
-------------	---

ID	SP.5
Narrative	<p>Core Devices will be installed in locations where they are vulnerable, therefore a compromise of a device is likely to occur.</p> <p>Steps should be taken to minimise the impact of a compromise on the end-to-end system. These steps could range from individual Cryptographic Modules through to the security architectural design.</p> <p>For example, such controls could be that cryptographic material, such as keys, are not shared amongst devices. This can significantly reduce the risk of compromise of cryptographic material of one device affecting another.</p>

Requirement	Core Devices will prevent the modification and disclosure of Critical Commands.
ID	SP.6
Narrative	<p>Critical Commands need to be secured against modification and/or disclosure, either accidentally or maliciously.</p> <p>Example controls could include:</p> <ul style="list-style-type: none"> • Encryption to mitigate accidental or malicious disclosure • Use of cryptographic operations such as hashing and digital signatures to mitigate accidental or malicious modification.

Requirement	Core Devices should be designed to not fail in a manner that would compromise their security, that of other Core Devices or the End-to-end System.
ID	SP.7
Narrative	<p>Failure of Core Devices will occur within the lifetime of the end-to-end system.</p> <p>Devices should take steps to ensure they do not fail in a manner that would compromise security, such as leaving data unencrypted or credentials available in an insecure manner.</p>

Requirement	Core Devices containing personal, operational or Sensitive Data that are being disposed of, shall be done so in such a way that the data is securely deleted.
ID	SP.8
Narrative	Core Devices may be replaced throughout the duration of the Programme. A number of these Core Devices store, or have the potential to store, personal and/or operational data.

	<p>If devices are to be reused or disposed of, personal, operational and Sensitive Data must be securely deleted to ensure that it cannot be easily retrieved once the Core Device has been disposed of.</p> <p>This is in-line with the Data Protection Act and security good practice.</p>
--	--

Requirement	Core Devices shall have a level of resistance against Electricitytro Magnetic Interference (EMI) attacks in line with the requirements of MID and the EMC directive.
ID	SP.9
Narrative	<p>Solid state electricitytronics are vulnerable to deliberate electricitytromagnetic interference. Steps should be taken to detect these attacks and mitigate them when they occur.</p> <p>Protection mechanisms against EMI attacks could include the shielding of key components or detection mechanisms for the symptoms of EMI in components.</p> <p>These mechanisms and the device must be compliant with the EMC directive.</p>

Requirement	Core Devices shall verify the authenticity of the source of firmware updates before they are applied.
ID	SP.10
Narrative	<p>Firmware within Core Devices should be received unmodified and accepted only from trusted and authorised sources. Core Devices must verify that firmware images received have come from an appropriate source, such as the Smart Meter Equipment Manufacturer.</p> <p>This can be achieved through using techniques such as code signing and/or digital signatures.</p>

Requirement	Core Devices shall verify the integrity of firmware before they are applied.
ID	SP.11
Narrative	<p>Firmware updates within Core Devices should not be modified between point of manufacture and installation on the device.</p> <p>Core Devices must verify that any new firmware it receives has not been tampered with or modified before it is applied.</p> <p>This could be achieved through the source of the firmware images (e.g., Smart Meter Equipment Manufacturers) implementing code signing, and verification</p>

	procedures which allow endpoint verification by the Core Device.
--	--

Requirement	Core Devices shall not accept firmware updates that are not from an authenticated source or have failed verification and integrity checks.
ID	SP.12
Narrative	<p>Firmware images that are received by Core Devices must come from an authenticated source and have their integrity verified.</p> <p>If firmware updates fail authentication or verification checks they must not be installed on the Core Device.</p>

Requirement	Core Devices shall confirm the integrity of their current firmware image when it is loaded or executed.
ID	SP.13
Narrative	<p>Changes in operating firmware of Core Devices during power down or sleep mode could affect the security of the Device. Core Devices should ensure that any changes to operating or stored firmware can be detected.</p> <p>This could be achieved through the Core Devices checking the firmware against the integrity attribute provided on installation by the Smart Meter Equipment Manufacturer, or various hardware controls.</p>

Requirement	Core Devices shall store security credentials and supporting data in a secured area or Cryptographic Module.
ID	SP.14
Narrative	<p>Security credentials will be used by the end-to-end System to protect the confidentiality and integrity of data and communications.</p> <p>Compromise of these credentials could undermine the security of the system.</p> <p>Credentials will need to be stored in a secure manner. This could be achieved through the use of a Cryptographic Module or a partitioned area of secure storage within existing components.</p>

Requirement	Core Devices will have the ability to store Sensitive Data and/or Personal Data, in a manner that protects it from unauthorised disclosure or modification.
ID	SP.15

<p>Narrative</p>	<p>It should not be possible for data that will have a material impact on device operation, metrology or supply or that is personal, to be altered or disclosed in an unauthorised manner.</p> <p>This could be implemented through cryptographic functions such as encryption, data signing and verification or validation checks in hardware.</p> <p>Protection against accidental corruption of data could be achieved through cyclic redundancy checks, check sums or other parity checks.</p>
------------------	--

<p>Requirement</p>	<p>Core Devices that include disabled or unused functionality shall ensure that this functionality will not compromise their security, that of other Core Devices, or the End-to-end System.</p>
<p>ID</p>	<p>SP.16</p>
<p>Narrative</p>	<p>Core Devices may include functionality which can be disabled for sale in particular markets or for particular deployment scenarios.</p> <p>If this functionality is disabled it should be done so in a manner that will prevent it undermining the Security Functionality of the device.</p> <p>This could be achieved through hardware means such as chip or trace removal, or in software.</p>

<p>Requirement</p>	<p>Core Devices shall support the capability to update or revoke Security Credentials remotely.</p>
<p>ID</p>	<p>SP.17</p>
<p>Narrative</p>	<p>Security credentials will be used by the End-to-end Smart Metering System to provide mechanisms for access control, identification and assurance of confidentiality and integrity.</p> <p>Compromise of these credentials could undermine Security functionality that relies on a credential. In the event of a compromise and during normal operation it must be possible to refresh or replace Security Credentials.</p> <p>The Core Device should not revoke all Security Credentials – it should be carried out on a per-credential basis as part of a managed process of lifecycle.</p>

Smart Meter Requirements

1.155. These requirements apply to the Metering devices in the Smart Metering system:

Requirement	The Smart Meter shall verify the authenticity of the source of all Requests and Commands when it is the endpoint of the communication.
ID	SP.18
Narrative	<p>The Smart Meter needs to verify the identity of the sender of Requests and Commands.</p> <p>The sender or source may be local, such as a Smart Meter maintenance engineer visiting the premise, or a third party via the Smart Metering network such as the DCC or Energy Supplier.</p> <p>Authentication may involve using cryptographic keys and/or digital certificates to verify the identity of the sender.</p> <p>Authentication may occur on a per-command/request level or may be a property of other session or channel authentication.</p>

Requirement	The Smart Meter shall check the authorisation of the source of all Requests and Commands it receives when it is the endpoint of the communication.
ID	SP.19
Narrative	<p>The Smart Meter needs to verify that senders of Requests and Commands have the access rights to perform the requested operation.</p> <p>Once the sender has been authenticated, the Smart Meter will authorise the Request or Command by checking the corresponding access credentials, which can be in the form of passwords, cryptographic keys or digital certificates.</p>

Requirement	The Smart Meter shall check the validity of the contents and format of all Requests and Commands when it is the endpoint of the communication.
ID	SP.20
Narrative	<p>Attackers may use malformed Request and Command messages to seek vulnerabilities in Smart Meter firmware and exploit them to gain access to the Smart Meter and Sensitive Data.</p> <p>This requirement also aims to protect against non-malicious message corruption due to accidental or intentional system changes.</p> <p>Message format validation enables Smart Meters to identify and drop malformed, out-of-order and unexpected messages. High numbers of malformed messages</p>

	<p>should also raise an alert to take further actions against a possible attack.</p> <p>The Smart Meter may also need to validate the headers or contents of messages when it is the repeater of messages.</p>
--	--

Requirement	The Smart Meter shall verify that Critical Commands received have not been altered in transit by unAuthorised Parties when it is the endpoint of the communication.
ID	SP.21
Narrative	<p>SM HAN and WAN security requirements protect Critical Commands during transmission; it may, however, still be possible to alter these commands at intermediate locations.</p> <p>Verification can be achieved using digital signatures or a Message Authenticating Code (MAC) produced by the sender party.</p>

Requirement	The Smart Meters shall ensure that data used for metrology or supply of energy cannot be amended or altered without detection.
ID	SP.22
Narrative	<p>If data used for metrology or supply can be amended/changed without detection, there is an increased risk of fraud through attackers changing data such as tariff details or prepayment balances.</p> <p>Therefore, some form of integrity of the metrology or supply of energy data is required. Integrity protection should provide a verifiable piece of security information to be sent along with the data.</p> <p>This security information can be a digital signature or a MAC produced by the Smart Meter to be verified by the receiving party, e.g., Energy Supplier.</p>

Requirement	The Smart Meter shall incorporate tamper resistance, notification and evidence measures to deter and detect unauthorised physical access to the Smart Meter.
ID	SP.23
Narrative	<p>The Smart Meter should use tamper-evident coatings, seals or resistant locks on removable covers. These must provide evidence if attempts are made to physically access the internal workings of the Smart Meter and critical security parameters within it.</p> <p>Basic tamper resistant controls will make it more difficult to physically access the</p>

	<p>Smart Meter.</p> <p>FIPS 140-2 Level 2 and 3 provides a detailed description of tamper evidence and resistance controls, respectively, for security devices.</p>
--	---

Requirement	The Smart Meter shall provide a local audit trail for all Sensitive Events that occur.
ID	SP.24
Narrative	<p>The Smart Meter will capture event logs throughout its use within customer premises. Some of this information will be generated by Sensitive Events that need to be reported to the DCC and Third Parties.</p> <p>These Security Logs will be stored on the Smart Meter and the capability shall exist to transmit them to the DCC and to Authorised Third Parties.</p> <p>The Smart Meter needs to provide the ability to store Security Logs in the event that WAN communications are down.</p>

Requirement	Amendments to local Security Logs within the Smart Meter shall be restricted to authorised Smart Meter security functions.
ID	SP.25
Narrative	<p>Security Logs will be created and appended by functionality built into the Smart Meter firmware. The integrity of these logs needs to be preserved to establish a verifiable audit trail for Sensitive Events.</p> <p>Preserving the integrity of audit logs could be achieved by:</p> <ul style="list-style-type: none"> • Restricting write access to Security Log storage • Prohibiting deletion of Security Logs • Frequent transmission of Security Log data • Use of partitioned or separate storage for Security Logs.

Requirement	The Smart Meter shall provide an alert when a safety/tamper event has occurred or if a Smart Meter failure has been detected.
ID	SP.26
Narrative	<p>Alerts are generated for Sensitive Events within the Smart Meters that require immediate action. This includes:</p> <ul style="list-style-type: none"> • Safety events

	<ul style="list-style-type: none"> • Tamper events • When a high number of anomalous messages (such as malformed, out-of-order and unexpected messages) are received • When a detectable Smart Meter failure has occurred. <p>Smart Meters may use special registers to record physical tampering of the metering equipment. On detection of these events, the Smart Meter will send an alert message to the DCC and/or Energy Supplier as soon as a connection is available. Safety/tamper registers will be reset only by authorised staff following an investigation of the Smart Meter condition.</p> <p>Thresholds can be set for what is considered to be a high number of malformed, out-of-order and unexpected messages received within a given time period. If the Smart Meter receives more messages of these types than the set threshold, an alert is sent to the DCC/Energy Supplier.</p>
--	--

Requirement	Smart Meters shall have the ability to store the expected maximum number of Security Log entries generated in a period of time at least equal to the Smart Meter WAN SLA plus a reasonable safety margin.
ID	SP.27
Narrative	<p>Events that occur on Smart Meters, in particular Sensitive Events, will need to be logged so that the DCC/Energy Suppliers are able to keep track of the current and previous states of them.</p> <p>However, it may not be possible for the Smart Meter to transmit new Security Log entries to the DCC/Energy Supplier immediately, due to WAN communications being down.</p> <p>Therefore Smart Meters will need the capacity to store log entries during a WAN outage. The Service Level Agreement of the Smart Meter WAN plus a reasonable safety margin provides an upper limit to such a delay.</p>

Requirement	Consumers with Smart Meters in communal areas shall have the ability to stop their personal data, outside of that needed for MID or other regulation, being displayed on the Smart Meter.
ID	SP.28
Narrative	<p>To ensure consumer privacy, Meters must contain functionality to prevent the display of Sensitive Data.</p> <p>For example this could be a simple PIN Number, a blanked Meter display or other controls.</p> <p>Sensitive Data does not preclude the display of data required under MID or other</p>

	regulations.
--	--------------

IHD Requirements

1.156. These requirements apply to IHD devices within the Smart Metering system:

Requirement	An IHD which displays information above the minimum specification must support functionality for a user to control when personal information is displayed.
ID	SP.29
Narrative	<p>An Energy Supplier may offer its customers IHDs which are more advanced than the minimum specification requires. In this case the customer needs to be given control over when their personal information is displayed on the IHD.</p> <p>This could be achieved through a simple 'mode' button, a 'home' screen or screen saver.</p>

Communications Hub Requirements

1.157. These requirements apply to the Communications Hub(s) within the Smart Metering system:

Requirement	The Communications Hub shall verify the authenticity of all devices and systems that request access prior to allowing communication, where the Communications Hub is acting as a channel and not the end device.
ID	SP.30
Narrative	<p>The Communications Hub will act as a gateway between the SM HAN and WAN and route Requests, Commands and Data between the two. Only messages from authentic and Authorised Parties should be accepted and forwarded on to the relevant destination.</p> <p>Once authenticated, the Communications Hub will authorise the Request or Command by checking the corresponding access credentials, which can be in the form of passwords, cryptographic keys or digital certificates.</p> <p>Mechanisms should be in place to prevent Requests or Commands being sent to the Smart Meter directly (i.e. by bypassing the Communications Hub).</p>

Requirement	The Communications Hub shall verify the authenticity of all devices and systems that request access prior to communication where the Communications Hub is the endpoint.
ID	SP.31
Narrative	<p>The Communications Hub may be the intended endpoint of messages such as a firmware upgrades. Only messages from authentic and Authorised Parties should be accepted.</p> <p>Once authenticated, the Communications Hub will authorise the Request or Command by checking the corresponding access credentials, which can be in the form of passwords, cryptographic keys or digital certificates.</p>

Requirement	The Communications Hub shall check the validity of the format of all Requests and Commands when the Communications Hub is the endpoint.
ID	SP.32
Narrative	<p>Attackers may use malformed Request and Command messages to seek vulnerabilities in Communications Hub firmware and exploit them to gain access to the SM HAN or Sensitive Data.</p> <p>Message format validation will enable Communications Hubs to identify and drop malformed, out-of-order and unexpected messages. High numbers of malformed</p>

	messages should also raise an alert to take further actions against a possible attack.
--	--

Requirement	The Communications Hub shall verify that Critical Commands received have not been altered in transit by unAuthorised Parties, when the Communications Hub is the endpoint.
ID	SP.33
Narrative	<p>SM HAN and WAN security requirements protect Critical Commands in transmission; it may, however, still be possible to alter these commands at intermediate locations.</p> <p>Integrity verification involves verifying the security information sent along with the original Critical Command and its data portion. This security information can be a digital signature or a Message Authentication Code (MAC) produced by the sender party.</p>

Requirement	The Communications Hub shall incorporate tampe-evident and tamper-resistance measures to prevent and detect unauthorised physical access to the Communications Hub components.
ID	SP.34
Narrative	<p>The Communications Hub should use tamper-evident coatings or seals. These must be broken to gain physical access to the internal workings of the device and critical security parameters within it.</p> <p>Basic tamper-resistant controls will make it more difficult to physically access the Communications Hub.</p>

Requirement	The Communications Hub shall provide a local audit trail for relevant Sensitive Events that occur both when the Communications Hub is acting as a channel or as an endpoint.
ID	SP.35
Narrative	<p>The Communications Hub will have sight of a large amount of information throughout its use within customer premises. Some of this information may be generated by Sensitive Events and needs to be reported to DCC and/or Energy Suppliers.</p> <p>These Security Logs will be stored on the Hub and transmitted to DCC and Energy Suppliers on a regular basis.</p> <p>The Communications Hub will also need to provide sufficient storage for the</p>

	<p>Security Logs in the event that WAN communications are down.</p> <p>Evidence and audit logs must be BS PD0008/0009 compliant.</p>
--	--

Requirement	Amendments to local Security Logs within the Communications Hub shall be restricted to authorised security functions.
ID	SP.36
Narrative	<p>Security Logs will be created and amended by security functionality contained within the Communications Hub.</p> <p>In addition they should include acknowledgement messages that Sensitive Event messages have been received by the DCC/Energy Supplier head-ends. The integrity of these logs needs to be preserved to establish a verifiable audit trail for Sensitive Events.</p> <p>Preserving the integrity of audit logs could be achieved by:</p> <ul style="list-style-type: none"> • Restricting write access to Security Log storage • Prohibiting deletion of Security Logs • Frequent transmission of Security Log data • Use of partitioned or separate storage for Security Logs. <p>Evidence and audit logs must be BS PD0008/0009 compliant.</p>

Requirement	The Communications Hub shall provide an alert when a safety/tamper event has occurred where the Communications Hub is the endpoint, or the Communications Hub has failed.
ID	SP.37
Narrative	<p>Alerts are generated for Sensitive Events within the Communications Hub that require immediate action. This includes:</p> <ul style="list-style-type: none"> • Safety events • Tamper events • A high number of anomalous messages (such as malformed, out-of-order and unexpected messages) are received • Communications Hub failure has occurred. <p>On detection of this event, the Communications Hub will send an alert message to the DCC and/or Energy Supplier as soon as a connection is available.</p> <p>Tamper events will be reset only by authorised staff following an investigation of</p>

	<p>the Communications Hub condition.</p> <p>Thresholds can be set for what is considered to be a high number of malformed, out-of-order and unexpected messages received within a given time period.</p> <p>If an event crosses a configured threshold an alert is sent to the DCC/Energy Supplier.</p>
--	---

Requirement	The Communications Hub shall implement access control and authorisation to allow non Core Devices to access the SM HAN.
ID	SP.38
Narrative	<p>As the Programme progresses, other Non-Core Devices (i.e. not part of the SM HAN) may attempt to connect to the Communications Hub. The Communications Hub will therefore need to verify authorisation of these devices and implement access controls.</p> <p>This might be implemented, for example:</p> <ul style="list-style-type: none"> • Such devices may have a lower privileges within the customer's premises • Only known device types may be allowed to connect to the Communications Hub • White listing of devices on the Communications Hub may be employed.

Requirement	The Communications Hub shall be able to authorise communications between Core Devices on the SM HAN and between the Core Devices and other devices outside of the SM HAN.
ID	SP.39
Narrative	<p>The Communications Hub needs to act as the local point of trust within the customer premises. Due to its central role in the local architecture the Communications Hub is best placed to authorise devices to communicate with each other.</p> <p>Core Devices on the SM HAN may need to communicate with each other and, as the point of trust, the Communications Hub will authorise this communication. In addition, if Core Devices wish to communicate with other devices not on the SM HAN the Communications Hub, as the point of trust, will authorise this communication.</p>

Requirement	The Communications Hub shall have the ability to store the expected maximum number of Security Log entries generated in a period of time at least equal to the Smart Meter WAN Service Level Agreement (SLA) plus a reasonable safety
-------------	---

	margin.
ID	SP.40
Narrative	<p>Events that occur on the Communications Hub, in particular Sensitive Events, will need to be logged so that the DCC/Energy Suppliers are able to keep track of the current and previous states of these Events.</p> <p>However, it may not be possible for the Communications Hub to transmit new Security Log entries to the DCC/Energy Supplier immediately, due to WAN communications being down.</p> <p>Therefore the Communications Hub will need the capacity to store log entries during a WAN outage. The SLA of the Smart Meter WAN plus a reasonable safety margin provides an upper limit to such a delay.</p>

Requirement	All device traffic from an Interface or Bridge to the SM HAN shall be controlled by the Communications Hub or SM HAN interface.
ID	SP.41
Narrative	<p>Consumer devices will be connected to the customer premises equipment through an Interface or Bridging device.</p> <p>The data types and flows between consumer devices and Core Devices must be subject to control to ensure that only the data types that the consumer devices are authorised to see, are sent to the device.</p>

Handheld Device Requirements

1.158. These requirements apply to devices used for Installation, Maintenance and Configuration within the Smart Metering system:

Requirement	Each Handheld Device shall be a uniquely identifiable asset within the End-to-end Smart Metering System.
ID	SP.42
Narrative	<p>Handheld Devices may give the operators enhanced capability in order to facilitate the installation and maintenance of Smart Metering devices. Therefore such devices need to be regularly audited and so they should be uniquely identifiable.</p> <p>In addition, the identification of a Handheld Device that is known to be 'rogue' enables its credentials to be revoked by, for example, updating certificate revocation lists with the Handheld Device certificates.</p>

Requirement	All Handheld Devices shall be registered on an asset register held by an appropriate party.
ID	SP.43
Narrative	<p>Given the nature of their portability, Handheld Devices are at particular risk of being lost/stolen and maliciously attacked.</p> <p>Therefore it is prudent for the asset owner or other appropriate party to keep a register of all Handheld Devices that they possess.</p>

Requirement	The Handheld Device shall be able to restrict access to authorised users only.
ID	SP.44
Narrative	<p>The Handheld Devices will need to have the functionality to ensure that only those users who are authorised to use the Handheld Devices are allowed to do so.</p> <p>This may involve checking the credentials of any user attempting to access the Handheld Device against an access control list to ensure that they are authorised.</p> <p>For example, credentials could be in the form of a smart card or a username/password combination.</p>

Requirement	There shall be a process for a Handheld Devices authorised operator to monitor and audit the operations and tasks performed by their Handheld Devices.
-------------	--

ID	SP.45
Narrative	<p>Regular audits of portable devices allow the device operators to assess their security status. Handheld Devices are particularly prone to being lost, stolen and maliciously attacked, so the operations and tasks performed by these devices need to be checked on an ongoing basis.</p> <p>In conjunction with access control, monitoring and auditing the operations and tasks that have been performed by the Handheld Devices allow the operations performed by authorised users to be audited.</p> <p>This allows the authorised operators to monitor whether authorised users are abusing the functionality offered by the Handheld Devices.</p>

Requirement	The set of operations or tasks that a Handheld Device can perform shall be restricted.
ID	SP.46
Narrative	<p>Handheld Devices may be lost, stolen or maliciously attacked by authorised or unAuthorised Parties. As a result the Handheld Devices should be able to perform only certain operations on the Smart Metering System in the home.</p> <p>For example, Handheld Devices may not be able to perform a credit prepayment operation but may be to disconnect/reconnect power.</p>

Requirement	A Handheld Device shall be able to perform only those tasks or operations that it has been assigned by an Authorised Party.
ID	SP.47
Narrative	<p>To ensure that Handheld Devices are allowed to perform only limited tasks, they should be programmed on a periodic basis, e.g., daily, to perform only the tasks or operations that they have been assigned.</p> <p>In addition, tasks and operations should be assigned only by Authorised Parties. This could be achieved through Authorised Parties issuing work orders or job sheets to particular Handheld Devices or authorised users.</p> <p>By limiting the usage of the Handheld Devices to pre-assigned tasks, the risks arising from lost or stolen devices to the Smart Metering System is limited. In addition it may stop fraudulent activity by authorised users.</p>

Requirement	There shall be a threshold for the number of Critical Commands that a Handheld Device can issue within a specified period of time before further authorisation is
-------------	---

	required.
ID	SP.48
Narrative	<p>Certain operations (such as enabling supply of energy and Smart Meter data erasure) that the Handheld Device may perform will need to incorporate thresholds.</p> <p>This will limit the impact on the End-to-end Smart Metering System if a Handheld Device is compromised.</p> <p>Authorised Parties could enforce this requirement by:</p> <ul style="list-style-type: none"> • Implementing a limit on each operation or task that the Handheld Device performs between physical connection to the device back at the appropriate depot, • Implementing a limit on each operation or task that the Handheld Device can perform without further user authorisation or authorisation by another user.

Requirement	There shall be a process for revoking the credentials of Handheld Devices.
ID	SP.49
Narrative	<p>Handheld Devices may be lost, stolen or maliciously attacked by authorised or unAuthorised Parties. As a result there must exist a process for revoking the credentials of specific Handheld Devices.</p> <p>For example this could be achieved through the revocation of Device Credentials or online authentication services.</p>

Requirement	Handheld Devices shall be stored securely whilst at their base location and during transit to consumer premises.
ID	SP.50
Narrative	<p>Given their portability, Handheld Devices are at particular risk of being lost/stolen and maliciously attacked. Due to this, special attention must be paid to their physical security.</p> <p>This can be achieved using a combination of controls such as:</p> <ul style="list-style-type: none"> • Restricting physical access to the Handheld Devices to authorised personnel through secure building access • Storing the Handheld Devices in secure containers during transit • Providing training to the authorised users of Handheld Devices.

HAN Requirements

1.159. These requirements apply to the HAN Technologies deployed within the Smart Metering system:

Requirement	The SM HAN shall implement network access control to ensure that Core Devices are protected from unauthorised access onto the SM HAN.
ID	SP.51
Narrative	<p>Network access controls will specify conditions for Core Devices to join and access the SM HAN.</p> <p>A secure network access will implement a combination of the following conditions before allowing devices to join the SM HAN:</p> <ul style="list-style-type: none"> • The network is in joining mode • Device has a valid security credential for SM HAN • Device has the correct device configuration. <p>Other conditions may be possible depending on the specific SM HAN technology.</p>

Requirement	SM HAN devices shall be mutually authenticated.
ID	SP.52
Narrative	<p>Source and destination Core Devices need to mutually establish their identities with each other prior to any information exchange over the SM HAN.</p> <p>This could be achieved using digital certificates and/or pre-shared cryptographic keys.</p>

Requirement	Sensitive Data transmitted over the SM HAN communication channels shall be protected against unauthorised disclosure and/or alteration.
ID	SP.53
Narrative	<p>SM HAN communication channels need to implement mechanisms to ensure the confidentiality and integrity of Sensitive Data.</p> <p>This could be achieved using a combination of the following controls:</p> <ul style="list-style-type: none"> • Device authentication • Channel encryption • Network access control. <p>If the SM HAN is unable to identify the sensitivity of the messages, it must protect</p>

	them to the highest level it supports.
--	--

Requirement	The SM HAN shall restrict the traffic types and protocols to and from itself and any other interfaces containing other smart devices.
ID	SP.54
Narrative	<p>The SM HAN should use only the protocols and services needed to meet the functional requirements. Unneeded or unused services or protocols could provide an alternative attack point.</p> <p>To prevent such attacks, the SM HAN will restrict traffic types and protocols between itself and any other interfaces.</p>

Requirement	Security roles shall be enforced within the SM HAN.
ID	SP.55
Narrative	<p>SM HAN security profiles specify a role for each SM HAN device that defines its access rights and interaction with other devices. These should be aligned to the SM HAN Application Profiles.</p> <p>A profile may be defined for each device or for each device type.</p> <p>The Communications Hub will manage these profiles and enforce access policies between devices. For example, the IHD may have read-only access to both gas and electricity Smart Meters.</p>

Requirement	Only Core Devices shall be authorised to connect to the SM HAN.
ID	SP.56
Narrative	<p>The SM HAN should provide a secure network within the customer premises. If consumers are able to connect non Core Devices such as Smart consumer devices to the SM HAN then, as they are not devices verified by the Energy Suppliers, DCC or Regulator, they may lead to a compromise of the security of the SM HAN.</p> <p>This could, in turn, compromise supply of electricity or gas to the customer's premises.</p>

Requirement	If consumer devices communicate with Core Devices on the SM HAN, they shall do so through Gateway Device which is installed on the SM HAN.
ID	SP.57

<p>Narrative</p>	<p>It is likely that consumers will wish to connect alternative devices to the SM HAN to make use of the Data present within the system.</p> <p>These consumer devices may communicate with Core Devices on the SM HAN, for example, to obtain readings of real-time energy usage.</p> <p>Control over such communication between the secured Core Devices on the SM HAN and unverified consumer devices is enforced by channeling it through a Gateway Device.</p> <p>This Interface or Bridge must include rules to limit communication between the Core Devices and consumer devices.</p>
------------------	--

<p>Requirement</p>	<p>Core Devices that connect to the SM HAN directly shall meet the security requirements.</p>
<p>ID</p>	<p>SP.58</p>
<p>Narrative</p>	<p>Core Devices within the SM HAN carry out metrology and have the functionality to enable and disable the supply of energy. The SM HAN may be exposed to risks from these devices if they have a lower Security Posture.</p> <p>To minimise the risk and maintain the security of the SM HAN, Core Devices that connect directly to the SM HAN must meet the security requirements.</p>

<p>Requirement</p>	<p>Core Devices that connect to the SM HAN directly shall use the Communications Hub for external network access or must implement the Communications Hub requirements.</p>
<p>ID</p>	<p>SP.59</p>
<p>Narrative</p>	<p>Core Devices that connect to the SM HAN may also connect to other communications providers or networks.</p> <p>This could introduce possible interconnections between the SM HAN, WAN and other networks. Devices implementing this functionality should either be attached to the Consumer HAN or meet the security requirements for a Communications Hub.</p>

Pre-Payment Requirements

1.160. These requirements apply to the Pre-Payment functionality within the Smart Metering system:

Requirement	The Smart Meter shall verify the authenticity of a Unique top-up Reference Number (UTRN) when a remote or local Prepay top-up or Balance adjustment command is received.
ID	SP.60
Narrative	<p>This control ensures that a valid UTRN has been issued by the correct issuer for the correct Smart Meter. It prevents malicious parties using rogue UTRNs for financial benefit.</p> <p>Implementation of this control can include a combination of sequence numbers, timestamps, digital signatures and cryptographic keys unique to each Smart Meter.</p>

Requirement	The Smart Meter shall not accept the same UTRN more than once, whether entered either remotely or via manual entry.
ID	SP.61
Narrative	<p>Customers and attackers will have access to a large number of used UTRNs. It may be possible to reuse these UTRNs if, for example, the generation algorithm generates a limited set of unique UTRNs for each Smart Meter.</p> <p>To prevent reuse, the UTRN generation algorithm could use time, random number elements or a different set of sequence numbers for each Smart Meter. It may also need a new cryptographic key to ensure a different sequence of UTRNs for each iteration.</p>

Requirement	Any cryptographic functionality used in UTRN generation shall be FIPS (or an equivalent) approved.
ID	SP.62
Narrative	<p>Weak generation algorithms may allow attackers to re-create the UTRN sequence or completely reverse-engineer the generation algorithm.</p> <p>Equivalence will be demonstrated by an algorithm passing the Cryptographic tests included in the CESG Consumer Product Assurance Handbook. <i>[This is currently awaiting publication]</i></p>

Requirement	The algorithm used for UTRN generation shall be published.
-------------	--

ID	SP.63
Narrative	Prepay functions will implement a number (UTRN) generation algorithm based on approved cryptographic algorithms. The resulting algorithm should be open and have undergone an independent security review. This is best achieved when the algorithm is published and open for review by security professionals.

Requirement	Each UTRN shall be applicable only to the Smart Meter it was generated for.
ID	SP.64
Narrative	<p>A UTRN that is not unique for a particular Smart Meter might be used in multiple Smart Meters, resulting in financial fraud and loss of confidence in the system.</p> <p>To personalise the UTRN sequence, a unique parameter will be used for each Smart Meter during UTRN generation, such as a cryptographic key.</p> <p>It must be extremely unlikely that a UTRN issued for one Smart Meter will work in another Smart Meter.</p>

Requirement	Smart Meters shall implement mechanisms to limit the number of incorrect UTRN entries that can be manually entered within a defined period of time.
ID	SP.65
Narrative	<p>UTRNs may be vulnerable to a brute-force attack, where large numbers of UTRNs are entered in an attempt to find a valid UTRN. Without this control, an attacker can attempt a large number of UTRNs on a Smart Meter until a correct one is found.</p> <p>Core Devices may delay user input with each wrong entry and send an alert to the supplier if a high number of wrong entries is received. The delay should be increased for consecutive invalid entries.</p> <p>If a check digit is used in UTRN generation then entry attempts that are rejected by its failure need not be fed into this delay mechanism.</p>

Requirement	The Core Device should deter and detect malicious attempts to enter UTRNs.
ID	SP.66
Narrative	<p>UTRNs may be subject to a brute-force attack, where large numbers of UTRNs are entered in an attempt to find a valid UTRN. Blocking User Input completely after a number of incorrect tries may lead to a Denial of Service condition.</p> <p>Core Devices may delay user input with each wrong entry and send an alert to the</p>

	<p>supplier if a high number of wrong entries is received. The delay should be increased for consecutive invalid entries.</p> <p>The Core Device should not block UTRN entry following invalid tries; this may result in a Denial of Service condition.</p>
--	---

Appendix A: Glossary

Term	Definition
Access Control (AC)	The method used to ensure that access to meter data is only available to properly Authorised Parties.
Alarm	A type of 'Event'
Alert	A type of 'Event'
Anomalous Messages	Denotes messages that are malformed, out-of-order or unexpected.
Approved Device	These are devices that have gone through an agreed approval process The approval may be of the type rather than the device. They may be identified by a appropriate approval markings.
Arming	Putting the meter into a state where physical interaction can close the Load Switch/open the Valve resulting in restoration of the supply.
Attach	See 'Pair'
Authenticated Device	A device that has gone through the appropriate processes to allow it to be attached to the SM HAN, including approval type and approval by a party with suitable authority.
Authorised Party	A party authorised (by whatever rules are agreed) to interact with the Smart Metering System. An example could be Supplier/DCC/Network/Consumer.
Authorised approval body	A body that is recognised as able to grant approval.
Auto-Restoration	A function within the meter such that the supply is restored automatically after a configured period of time. This feature is designed to restore supply in the event of WAN failure.
Auxiliary Switches	Switches controlling circuits within the home such as electric storage heating or immersion heaters found in some Economy 7 installations. Specific load control switches that are configured for time of operation within the SMS. (Similar to the functionality provided by legacy metering arrangements.)
Bar Code	A Bar Code is an optical machine-readable representation of data, which shows data about the object to which it attaches.
Battery Compartment	Any access terminal, door, module or detachable housing that has to be removed so that the battery can be replaced.
Battery Powered Device	Battery Powered Devices are devices (components of the metering system) that do not draw their normal source of power from mains electricity supply but take their power from a battery. The term Battery Powered Devices is NOT used to describe devices that may use batteries as a backup source of power.
Block	A means of charging differing amounts for energy consumed, based on the quantity of energy consumed (i.e. the first 100 units to be charged at x pence, the next 500 units to be charged at y pence).
Block Tariff	A tariff structure that uses tier thresholds with different unit prices during a billing period. Also known as a 'Consumption Tariff', where the price rate being applied is dependent on the quantity of energy already consumed during a

Term	Definition
	defined period of elapsed time.
Bridge	See 'Interface'
Bridging Device	See 'Gateway'
BST	British Summer Time starts on the last Sunday in March and ends on the last Sunday in October, at 1.00 am Greenwich Mean Time (GMT).
Can	Indicates a clause or requirement is mandatory, without deviation, but may be subject to other conditions to be fulfilled.'
Call Set Up	A call set up is part of establishing a WAN connection. It is done in response to a request for connectivity and a successful call set up allows a communication exchange to take place
Certified	An entity (this may be any distinguishable entity – a device, a distinguishable part of a device – which may be itself a physical or logical, a person or organisation) that has been formally noted as approved. Some formal documentation associated with the entity provides evidence of this approval. It may be the specific entity that is certified, or it may be the type that is certified and examples of that type regarded as certified as a result.
Clock Change	Time change to account for BST.
Commercial Interoperability	The terms on which a new supplier can use the meter and related equipment when a customer changes supplier.
Command	Denotes a control or configuration message which on receipt would cause an action or event to be carried out, e.g., meter tariff update command. Often a Command will also generate a response message. A command can be issued remote or local means
Component	Main constituent devices that make up a Smart Metering System; e.g.: gas and electricity meters, Communications Hub, IHD.
Configurable	An operation is configurable where it operates according to parameters, the values of which can be changed.
Connect	See 'Pair'
Contact	An electrical relay used to control the flow of power in a circuit.
Consumer	End user of energy as supplied through a gas or electricity meter.
Consumer HAN (C HAN)	Customer's Home Area Network for which they have full responsibility, (e.g. Customers broadband service). This is not the SM HAN.
Consumer's Supply	In the case of gas: Gas as provided from the outlet of ECV into the consumer's premises via the smart gas meter. In the case of electricity: Electricity as provided from the outlet of the main service fuse into the Consumers premises via the Smart Electricity Meter.
Critical Peak Pricing (CPP)	A temporary price for electrical energy during a time of peak total system or local distribution system demand. Prices are assessed for certain hours on 'event days' (often limited to 10-15 per year). Prices can be 3-10 times as much during these few hours. Typically combined with a ToU rate, but not always.
Credit mode	Smart Meters will be capable of switching between prepayment and credit mode. When operating in credit mode, customers will be billed for their energy

Term	Definition
	after using it.
Commission (to)	Process by which the SMS or any of its components have been installed, is then tested to verify if it functions according to its design or specifications.
Communications Hub	A device or set of devices located at the customer's premises which will have the capability to communicate with the SM HAN and the Smart Meter WAN. It is a component of the SMS.
Component	A constituent part of the Smart Metering System. Examples of components are meters, IHD.
Core Devices	<p>Smart Metering devices that will be in the customer's premises which have the ability to affect metrology or supply of energy. In addition, the basic IHD and any Interface or Bridge to connect Core Devices to consumer devices are considered as Core Devices. Core Devices may include:</p> <ul style="list-style-type: none"> • Basic IHD, • Electricity Smart Meter, • Gas Smart Meter, • Communications Hub, • SM HAN module (if separate from the Communications Hub), • WAN module (if separate from the Communications Hub), • Interface or Bridge to connect Core Devices to consumer devices, • Micro-generation Meters.
Core Systems	<p>Core Systems are End-to-end Smart Metering Systems that are operated by Energy Suppliers, Network Operators or DCC including:</p> <ul style="list-style-type: none"> • Head-ends, • WAN systems and infrastructure, • Smart Metering supporting systems.
Counter	A register that counts the number of occurrences that a measured value is detected (e.g. unit of energy passed).
Cyclic Redundancy Check (CRC)	Cyclic Redundancy Check - A cyclic redundancy check (CRC) is an error-detecting code designed to detect accidental changes to raw computer data and is commonly used in digital networks and storage devices such as hard disk drives.
Critical Command	<p>These are Commands which can potentially cause loss of energy supply. We define Critical Commands following the Smart Metering IS1 Risk Assessment; they include but are not limited to:</p> <ul style="list-style-type: none"> • Credit/prepay switchover, • Remote enablement/disablement of supply, • Firmware update/upgrade of the Smart Meters, Communications Hub, SM HAN and WAN modules, • Prepay top-up, • Prepay configuration, • Prepay balance adjustment, • Smart Meter data erase, • Cryptographic key update, • Communication network management commands.
Critical National Infrastructure (CNI)	An asset, or group of assets, that are deemed essential for the functioning of a society or economy.
Cryptographic Module	A Cryptographic Module shall be a set of hardware, software, firmware, or some combination thereof that implements cryptographic functions or processes, including cryptographic algorithms and, optionally, key generation,

Term	Definition
	and is contained within an explicitly defined perimeter that establishes its physical bounds.
Customer	Any person supplied or entitled to be supplied with electricity or gas by a supplier.
CV	Calorific Value (of gas).
Data	<p>Data is defined as the contents of messages or information within the End-to-end Smart Metering System held on memory or media. Data can include, but are not limited to, the following:</p> <ul style="list-style-type: none"> • Cryptographic keys, • Cryptographic certificates, • Firmware images, • Smart Meter confirmation messages, • Smart Meter configuration data, • Smart Meter readings, • Smart Meter registration data, • Prepay adjustments, • Prepay balances, • Prepay top-up information.
Data Type	A term used to classify one of the various types of data. For example, cryptographic keys are a particular Data Type.
DataCommsCo (DCC)	New proposed entity which will be created and licensed to deliver central data and communications activities. DCC will be responsible for managing the procurement and contract management of data and communications services that will underpin the Smart Metering System.
DCC Operational Data	Configuration, operational and organisational data that pertains only to the DCC. This excludes administrative and financial data that are out of scope of the Security Requirements.
DCC User	This terms describes any user that connects to the DCC User WAN, which may include: Energy Suppliers, Distributed Network Operators (DNOs), and value add third parties.
DCC User WAN	The Wide Area Network (WAN) that connects a DCC User to the DCC.
De-energisation (electricity)	De-energise the supply by removing the main fuse.
Demand	<p>Refers to the maximum amount of electrical energy that is being consumed at a given time. This is calculated using:</p> $\text{Energy recorded in current period} \times (60 / \text{minutes in demand period})$
Demand Response - DR	Managing use by reducing or shifting energy use in response supply conditions. E.g. reducing consumption at critical times or in response to market prices.
Demand-side management	Demand-side management (also known as load management) involves energy consumers managing demand in response to changes in the balance between supply and demand on an electrical system, usually in response to a price signal.
Demand Values	The Demand Value are half hourly demands and these are identified by the time of the end of the Demand Period'. Expressed in kW, kVAr, kVA, twice the value of kWh, kvarh, or kVAh recorded during the demand period.

Term	Definition
Department of Energy and Climate Change (DECC)	The Department of Energy and Climate Change (DECC) was created in October 2008, to bring together: energy policy and climate change mitigation policy.
Device	Any electronic or electromechanical machine or component that forms part of the SMS or is paired with the SM HAN. Device always refers to hardware.
Device Class	Device class is a collection of devices that have similar characteristics and that can be managed in a similar manner.
Disablement (remote)	Opening of the Load Switch/closing of the Valve.
Disconnection (electricity)	Supply disconnected by removing the electricity meter.
Distributed generation	Any generation (including combined heat and power schemes) which is connected directly into the local distribution network, as opposed to the transmission network. The electricity generated by such schemes may be consumed locally rather than being transported for use across Great Britain.
Dumb Mode	Smart capable meter whereby smart functions cannot be used. E.g. can't be communicated with remotely due to no signal, communication system failure, Supplier Agent doesn't have meter access (passwords etc.). Can then only be used for basic functions (like a dumb meter), e.g. recording consumption only. Has to be read on site manually.
ECV	Emergency Control Valve.
Electricity Meter	A measuring instrument that records the quantity of electricity supplied to a consumer.
Emergency Credit	Credit applied by a supplier when a meter is out of credit to avoid interruptions during defined time periods such as overnight.
End to End Smart Metering System	<p>The end-to-end Smart Metering System comprises of Smart Metering physical equipment and logical technology components within customers' premises, Smart Metering Systems held/operated by Energy Suppliers and other DCC Users, the Smart Metering communications infrastructure (wide area networks) and the entire DCC. Smart Metering physical equipment include but are not limited to:</p> <ul style="list-style-type: none"> • Smart Meters, • IHDs, • Communications hardware within the customer premise. <p>Logical technology components include but are not limited to:</p> <ul style="list-style-type: none"> • Smart Meter Firmware, • Smart Meter Configuration Data, • Energy Suppliers and DCC configuration data and related information.
Energy Supplier	A company licensed by Ofgem to sell energy to, and to bill, customers in Great Britain.
EPIHD (Enhanced Prepay IHD)	This is a non mandated type of enhanced IHD to provide prepayment functionality for consumers where their Smart Meter(s) are deemed to be in inaccessible positions.
Event	An occurrence that can be detected by the a component of the Smart Metering System that requires an action. Specific examples include low battery detection, battery cover open. The action on an event may be only to log that the event has happened.

Term	Definition
Fault	Failure within a component such as to compromise its functionality. This may be minor; e.g. a temporary communications failure; or major e.g. Contactor or Valve failure to operate
FIFO	First In First Out
Firmware	Firmware is software that's embedded in hardware for the purpose of controlling the hardware. Is stored in non-volatile memory and which cannot be changed during the normal operation of the component in which it resides. Firmware is expected to be upgraded only infrequently. There is no clear distinction between firmware and software, the difference is generally to do with the likelihood / expectation of changing the code and the memory area in which the code resides. Since there is not a clear distinction, the term Firmware is used to refer to any system code, whether it might be regarded as Software or Firmware. Any Smart Metering System component is likely to have firmware at more than one level – at least some of the code of any component will not be replaceable. References to firmware upgrade are, by definition, referring to firmware that is upgradeable.
Feed in Tariff (FIT)	A tariff based on the price paid per unit of electricity that is generated (measured via the FIT meter).
Friendly Credit	At certain times of the day the supply will not disconnect regardless of usage or credit status. Can also be referred to as non-disconnection period.B147
Functional Requirements	The minimum functions that must be supported by the different elements of the Smart Metering System to ensure the delivery of the benefits of Smart Metering. Describes what the Smart Metering System must do (not how it must do so).
Gateway	A device that acts as a go-between two or more networks that use the same protocols, or also converts one protocol or format to another.
gas meter	A measuring instrument that records the volume of gas supplied to a consumer.
gas meter Battery	An electrochemical cell component of gas meters that provides the power for the electrical operations of the gas meter.
Gas Safe	A register of competent gas engineers, only engineers who are registered as competent with Gas Safe are allowed to carry out work on gas installations within the UK.
Gas Valve	A gas Valve may be incorporated into a gas meter to allow or disallow the flow of gas into the consumer premise. It is distinct from the isolation, Valve or ECV.
Golden Unit	A bespoke designed and built test tool, usually a 'physical' machine. Used to provide a single test baseline to test components of differing origins carry out the same required functions. A model meter, IHD, communications-Hub or HHT used for substitution in interoperability testing of SMS components.
GMT	Greenwich Mean Time.
Half Hourly Meter	Since April 1990 electronic meters capable of recording electricity consumption in each half hour have been widely used. This is mandatory for all sites over 100 kW maximum demand and voluntary for sites under 100 kW. Typically the consumption records are recovered once a day by the data collector using telephone or radio data communications.
Head End (system)	Office based system, at either DCC, Supplier or other Authorised Party,

Term	Definition
	including databases etc. that hold all meter and billing information, and software that can interact with the Smart Meter System.
Hand Held Terminal	Devices used by Smart Meter Operators on behalf of Primary Industry Participants to install or maintain Smart Metering Equipment within the customer's premises. A portable device (designed for purpose or can be a ruggedised PDA, laptop, etc.) designed to interact with the Smart Metering System, either directly with individual components or via the HAN. The relationship is temporary or short term.
HHD	See 'Hand Held Device'
HHU	See 'Hand Held Terminal'
Home Area Network (HAN)	The Smart Metering HAN will be used for communication between Smart Meters, IHDs and other devices in premises. A short range network that is present within the proximity of the consumer's premises.
IGB	Interoperability Governance Board. Recommendation for a new body to be established to oversee the governance processes.
In-home display (IHD)	An in-home display is an electronic device, linked to a Smart Meter, which provides information on a customer's energy consumption.
IHD (minimum specification)	this is the mandated base specification IHD functionality as defined in the ESoDR.
IHD (Enhanced)	This is an IHD with greater functionality than that defined in the ESoDR
IOTWG	Interoperability Working Group.
Isolation (gas)	Removal of the Service.
Indicative Price per Unit	A unit price which is produced, including relevant cost components to provide a representative energy unit cost as an information air for consumers.
Industry Participants	Any organisation involved in the End-to-end Smart Metering System either in the foundation or enduring stages.
Information Assets	Information that has value to the end-to-end Smart Metering System.
Information Systems	The physical environment (e.g. buildings, communications facilities and links, computer hardware), information and data, software, service provision.
Installer	Person or persons who physically installs, configures, commissions or repairs equipment, as appropriate, in a consumer's premises.
Instantaneous demand	The load required at any designated instant.
Interoperability	The ability of diverse systems, devices or organisations to work together (interoperate). See also commercial interoperability and technical interoperability.
Interface	The Interface is a Core Device used to allow controlled data transfer between Core Devices and consumer devices. Interface is a tool and concept that refers to a point of interaction between components, and is applicable at the level of both hardware and software.
Interruption (gas)	Supply interrupted by closing the interrupt Valve (in the meter) locally or remotely.
IP (address)	Internet Protocol.

Term	Definition
ITR	Interoperability Test regime definition specific to this document relates to overall governance.
J	Joule.
kg	Kilogram.
kV	Kilovolt.
kVA	Kilo Volt-ampere.
kVAr	Kilo Volt-ampere reactive.
kW	Kilowatt.
kWh	Kilowatt-hour is a unit used to measure energy consumption in both electricity and gas. The kilowatt-hour is a unit of energy equal to 1000 Watt hours or 3.6 megajoules. Energy in Watt hours is the multiplication of power in Watts, and time in hours. A 100W light bulb left on for one day will consume 2.4 kWh (0.1*24).
Last Gasp	Last gasp is the ability, in the event of supply interruption greater than a few minutes, for the Smart Metering System to communicate this event before reverting to any back up supply (for example to keep the legal metrology function active).
Load Limiting	Load Limiting – can be achieved by opening the Load Switch for exceeding the following thresholds: <ul style="list-style-type: none"> • Maximum Demand Threshold – a configurable demand level • Energy Consumption Threshold – a configurable amount of energy that can be consumed during a defined period
Load Management	The process of balancing the supply of electricity on the network with the electrical load by adjusting or controlling the load rather than the power station output. This can be achieved by direct intervention of the utility in real time, by the use of frequency sensitive relays triggering circuit breakers, or by time clocks, or by using special tariffs to influence consumer behaviour.
Load Management Command	An over-riding instruction to disconnect the SMS controllable load following an allowed event via an Authorised Party or an over-riding instruction to re-connect the SMS controllable load following an allowed event via an Authorised Party. (Similar to the functionality provided by RTS in legacy arrangements.)
Load Managed Appliance	A consumer appliance that can accept and implement load management commands.
Load Switch	A device with automatic and/or manual reclose functionality within an electricity meter that when opened prevents the flow of electricity through the meter.
Local Alert	An Event/alarm/alert that is made available only to the SM HAN.
Local Communication	Communication (two way) via the SM HAN from a HHT or authorised interface device to the Smart Metering System, and from the metering system to the HHT or authorised interface device within the premise.
Local Interaction	A command initiated on the SM HAN sent to the meter e.g. via the HHT.
Local Time	The time in a particular region or area expressed with reference to the meridian passing through it.

Term	Definition
Local Top Up	Prepayment Specific. Local top up refers to consumer or Authorised Party manually entering the UTRN directly onto the meter.
Main Battery	Primary source of long term electrical power in a battery powered component of the Smart Metering System; e.g. the gas meter.
Major Security Incidents	These security incidents are those which have, will or have the potential to cause a Material Impact to the End-to-end Smart Metering System.
Material Impacts	An incident or event of any nature that has the potential to cause a Business Impact Level of 2 (or equivalent) or above. Business Impact Levels are defined using the HMG Business Impact Level tables.
Maximum Demand	Maximum Demand is stated in kW, averaged over the period of half an hour. It is measured by a meter that measures consumption (kWh). The maximum demand in kW is two times the kWh advance in the half hour of maximum consumption during a pre-determined period or between two meter readings measured in kW. Instantaneous demand can be higher than maximum demand measured in this way.
Maximum Volume Flow	Maximum volume flow in gas meter is a flow rate of 6m ³ of gas per hour
Measuring Instruments Directive (MID)	The Measuring Instruments Directive is a European Directive (2004/22/EC) that covers a number of different measuring instrument types, including active electrical energy meters and gas meters. The MID enables EU conformity assessment certificates to be issued, and the instrument can then be used in any EU Member State. The aim of the Directive is to create a single market in measuring instruments for the benefit of manufacturers and, ultimately, consumers across Europe.
Meshing	Some SMS architecture designs enable SMS Components to act as message relays to receive and pass on data messages or commands to another SMS Component that may be out of wireless communication range. Some meshing architectures enable the nearest random SMS Component to receive and pass on to the next until the intended SMS Component receives the messages or commands. In other cases the SMS Components may have a topology that forces the messages or commands to be passed to a predefined SMS Component. It should not be assumed that all SMS Architectures employ 'Meshing'.
Meter Asset Manager (MAM)	A person approved by the Authority as possessing sufficient expertise to provide gas meter-related services. A gas MAM essentially provides the services that would be provided by a Meter Asset Provider and Meter Operator in electricity.
Meter Asset Provider (MAP)	The party that owns the meter asset. Can be a supplier, bank, the customer etc.
Meter Balance	The amount of monetary credit held on a meter in PAYG mode.
Meter Element	A logical device that can measure a single flow of electricity. A 2 element meter can record consumption on 2 separate circuits.
Meter Integrity Sensor	A collective term for a range of sensor devices installed in the meter.
Metering Services	The provision to a customer of a meter that meets the prescribed limits for accuracy (currently +2.5% and -3.5%). It includes meter provision and meter operation.

Term	Definition
Meter Operator (MOp)	In electricity a MOp is responsible for the installation, commissioning, testing, repair, maintenance, removal and replacement of electricity metering equipment as defined in Section 1B of standard condition 36B of the distribution licence.
Metrology	Metrology is the science of measurement. When used here, metrology refers to aspects or components specifically pertaining to the measurement or recording of measurements according to the primary purpose of the meters.
Message	Alphanumeric or graphic one-way or two-way service that sends, receives and displays messages on a SMS component. A 'message' can refer to a Request, Command, alert, Security Log messages or any other type of message.
Meter Reading	A meter reading is the value of the meter index obtained when a meter is read by manual or automatic read.
Meter Register	A counter that records accumulated energy consumption.
Micro-generation	Micro-generation is the on-site generation by consumers, small businesses and communities at a small scale.
Module	Sub-assembly of a component that may be capable of on-site exchange; e.g. a communications module.
Modulus (of a number)	Absolute value without regard to sign.
MPAN	Meter Point Administration Number.
MPRN	Meter Point Reference Number.
Negative Testing	Refers to a test where there may be more than one pass or fail criterion within a single specified test action where additional combinations of test environment are applied. For example 'what happens if I also do this?'
Network Operators	These are organisations that are licensed by Ofgem that operate the distribution of gas and electricity within Great Britain. It includes, but is not limited to: <ul style="list-style-type: none"> • Distribution Network Operators (DNOs) • Independent Distribution Network Operators (iDNOs) • Gas Transporters (GTs) • Independent Gas Transporters (iGTs).
NMO	National Measurement Office.
Node	A node is any device connected to the SM HAN. Nodes can be meters, IHD, or various other approved devices.
Non-volatile memory	Memory that is retained in the absence of power supply.
Normal Working Condition	A device in normal working conditions is one that is installed and operational but one that is not being subjected to unusual demands.
Notified Body	Organisation that has been nominated by a member state and Notified by the European Commission. A Notified Body will be nominated based on designated requirements, such as knowledge, experience, independence and resources to conduct conformity assessments (to European Standards) of components.
OBIS	Object Identification System, as defined in IEC 62056-61, is a method for defining data objects.
Ofgem	The Office of the Gas and Electricity Markets (Ofgem) is responsible for

Term	Definition
	protecting gas and electricity consumers in Great Britain.
Off peak	Occurring or offered during a low demand period.
Off peak load	The load offered during a low demand period.
Other Industry Participants	<p>Other Industry Participants: These are organisations who are involved in, but not a significant part of, the End-to-end Smart Metering System either in the Foundation or Enduring stages. These include:</p> <ul style="list-style-type: none"> • Energy Service Companies (ESCOs), • Smart Metering Equipment Manufacturers, • Smart Metering System Manufacturers, • Smart Meter Operators (currently known as Meter Operator Providers or MOPs), • Smart Meter Asset Owners (currently known as Meter Asset Maintainers or MAMs), • WAN Providers, • Other Value Add Third Parties, • Consumers.
Outage	See 'Supply Interruption'
Outbound Communications	Outbound communication is communication from a device.
P	Pressure (of gas).
p/kWh	Price in pence per kWh used.
Pair(ing)	Means by which the local components of a Smart Metering System agree to communicate with each other and establish a connection. Typically this is achieved by exchanging a passkey between the components. Can be used interchangeably with Attach or Connect.
Passkey	The passkey is a code shared by the components, which proves that they have agreed to pair with one other. Other components that may attempt interfering communications are prevented from so doing because they will not have the passkey and thus cannot pair.
PAYG	Pay As You Go. A variation of Prepayment possibly having different rules applied to debt management and the interruption and restoration of the supply.
Peak instantaneous demand	The maximum demand at the instant of greatest load.
Physical Interaction	Human interaction with the meter (e.g. button press).
PIN	Personal Identification Number.
Positive Testing	Refers to a test where there is only pass or fail criterion within a single specified test action, where no additional combinations of test environment are applied.
Prepayment	System whereby a consumer pays for energy before it is supplied. Rules are applied to the interruption and restoration of the supply and may be applied to the consumers management of Debt. In the case of gas, CV and a PTZ conversion factor may be taken into consideration.
Primary Industry Participants	<p>These are organisations that are a significant part of the End-to-end Smart Metering System either in the Foundation or Enduring stage. These include:</p> <ul style="list-style-type: none"> • Energy Suppliers,

Term	Definition
	<ul style="list-style-type: none"> • DCC, • Network Operators.
Processes	A set of structured activities designed to accomplish a specific objective.
Profile	A method used for settlements to define pseudo half-hourly data from non-half-hourly meter tariff registers.
Programme	The Smart Metering Implementation Programme.
PTZ Conversion	Means by which the volume increments measured by a gas meter at a set of conditions of pressure, temperature and hence compressibility (Z) are converted to volume increments as if it were operating at base conditions.
Purge and Relight	<p>A gas engineer's term used to describe a process wherein an engineer visits site and ensures that the system can be safely reconnected to the gas system.</p> <p>This process is used where a gas supply has been interrupted or a is meter reconnected, it is necessary to ensure that the air or gas/air mixture is purged out of the pipes and the appliances relit and is burning correctly.</p>
RAM	Random Access Memory.
Randomise	A randomised event is one where the time that the event occurs is determined according to a probability distribution defined by use of an algorithm and parameters rather than at a specified time.
Rate	A means of charging differing amounts for energy consumed, based on the time of day the consumption occurred (i.e. energy consumed between midnight and 05:59:59 to be charged at x pence per unit, energy consumed between 06:00:00 to 23:59:59 charged at y pence per unit).
Reactive Power	Reactive Power is not real power. All devices consume real power to perform the work they are designed to do. Some devices also require reactive power. When this is required the kWh consumption recorded by a meter is not increased but the presence of reactive power can be measured in the form of a higher electricity current flow. That higher current flow causes higher electrical losses in the distribution network. Consequently some meters are designed to measure reactive power and small charges may be applied to reflect the cost of distributing the larger current flow.
Real Time	<p>The term "Real Time" is used in relation to communications when they are to be sufficiently high performance as to allow updates that are perceived to be indicating the current state or use.</p> <p>For example, a sampling and refresh rate on a consumption display of 5 – 10 seconds might be regarded as 'real time', a refresh rate of 30 minutes would not.</p>
Real Time Pricing (RTP)	Real time pricing, when each ½ hr period in the day has a different allocated tariff price.
Remote Communication	Communication (two way) via the WAN from a Head-end system to a Smart Metering System, and from the metering system to the Head-end system.
Remote disablement (electricity)	Interruption of the supply by opening the contactor (in the meter).
Remote Interaction	A command sent to the SMS via the DCC.
Remote interruption (gas)	Supply interrupted by remotely closing the interrupt Valve (in the meter).

Term	Definition
Request	Denotes a control or configuration message to which the response would contain data items, e.g., meter measurement reading request.
Restoration	Closing the Load Switch/opening the Valve by an Authorised Party restoring supply to the premises.
RF Repeater	An RF repeater is a device that receives and transmits the same radio signals. It may be used to allow devices whose signals could not otherwise reach each other.
Root Mean Square (RMS)	Is a statistical measure of the magnitude of a varying quantity.
Scalar	A parameter that is an input to an algorithm. A scalar value can hold only one value at a time.
SEC	Smart Energy Code.
Security Logs	Security Logs store information about events that have occurred on a device or system. For example an event could include but is not limited to: <ul style="list-style-type: none"> • Sensitive Events, • A Request or Command being received.
Security Posture	The risk level to which a system or organization is exposed. In organizations that use formal certification and accreditation processes, such as government departments, security posture is usually stated relative to its target risk profile.
Security Requirements	The Security Requirements are a result of the programme's intention to implement a risk based, informed approach to security. Through detailed security risk assessments, security principles and a detailed set of security requirements - covering both technical and organisational security areas - were developed.
Sensitive Data/ Information	Sensitive Data or Information denotes information that is essential to the secure operation of the End-to-end Smart Metering System. Data or information is considered essential if once disclosed or altered could potentially cause loss of energy supply as assessed in the Smart Metering IS1 Risk Assessment. Sensitive Data/Information includes, but is not limited to: <ul style="list-style-type: none"> • Configuration data, • Firmware data, • Metrological and calibration data, • Cryptographic keys and certificates.
Sensitive Events	These events are those which change the state of the Smart Meter and have a security impact. They include, but are not limited to: <ul style="list-style-type: none"> • Change of supplier, • Failed authorisation or authentication, • Firmware update/upgrade, • Remote enablement/disablement of supply, • Prepay UTRN (Unique top-up Reference Number) received, • Safety/tamper event raised, • High number of malformed, out-of-order or unexpected messages received.
Sensitive	A means of delivering value to customers (e.g., consumers, DCC Users).
Sequence number	A serial arrangement in which numbers follow in logical order or a recurrent pattern.
Shall	Indicates a clause or requirement is mandatory, without deviation.

Term	Definition
Should	Indicates a clause or requirement is the preferred option. However, an alternative option may be offered if it can be shown that it offers the same, or enhanced, performance to that specified in the clause or requirement provided that it is interoperable with the minimum requirement.
Simple Flat Rate	One price for all units of energy consumed with or without standing charge applied. (A flat price may also apply to any net energy exported to the grid).
Smart Appliances	An appliance that can alter the way in which it uses energy (consumption level or time of use) in response to changes in the balance between supply and demand, usually in response to a price signal.
Smart Base Meter	A Smart Base Meter is the basic assumptions for Electricity and Gas meters. The Smart Base Meter shall for instance, conform to GB industry requirements and standards in terms of basic functionality.
Smart Energy Code	The proposed new industry Code that will cover both gas and electricity sectors and will contain the detailed regulatory, commercial and technical arrangements applicable to Smart Metering during rollout and on an enduring basis.
Smart Grids	Smart grids, as part of an electricity power system, can intelligently integrate the actions of all users connected to it - generators, consumers and those that do both - in order to efficiently deliver sustainable, economic and secure electricity supplies.
Smart Meter	A meter which, in addition to traditional metering functionality (measuring and registering the amount of energy which passes through it) is capable of providing additional functionality for example two-way communication allowing it to transmit meter reads and receive data remotely. The proposed minimum functionality of Smart Meters is set out in the Functional Requirement Catalogue.
Smart Metering System (SMS)	The Smart Metering System refers to Smart Metering equipment in customers' premises. In the domestic sector, this equipment comprises the electricity Smart Meter, the gas Smart Meter, other compliant Smart Meters, the Communications Hub, the HAN, the WAN module and the IHD.
SMIP	The Smart Metering Implementation Programme (the Programme) is the Governments programme for implementing Smart Metering throughout Great Britain.
SM HAN	Smart Metering Home Area Network. See definition for 'HAN.'
SMTS	Smart Metering Technical Specification.
Software	A set of programs, procedures and algorithms held in the storage of the computer to provide the functions for computer usage. Often divided into application software (programs that do work users are directly interested in) and system software (which includes operating systems and any program that supports application software).
Special Day	A selected day that has a different profile than the one configured in the weekly profile (e.g. if Christmas day is a 'week' day, the special day allocation may change the meters configuration to a 'weekend' day).
Supply Interruption	Condition in which the voltage at the supply terminal is lower than 1% of the declared voltage, for a period in excess of 3 minutes.
Supplier	See 'Energy Supplier'

Term	Definition
SSC	Standard Settlement Configuration (each SSC is related to a fixed set of Time Pattern Regime Ids that relate to Settlement Registers on the Metering System).
STEG	Security Technical Experts Group.
Standing Charge	An amount of money collected from the consumer at a regular frequency (hourly/daily/monthly etc).
Switch	A mechanical device for opening or closing a circuit.
T	Temperature.
Tamper	A type of 'Event'.
Tariff	A table of fixed prices (for amount of energy consumed, exported or generated by a consumer) that is made up of various rates and tiers.
Technical Interoperability	The capability of systems or devices to provide and receive services and information between each other, and to use these services and information exchange to operate effectively together in predictable ways without significant user intervention. Within the context of the Smart Metering System, this means the seamless, end-to-end connectivity of hardware and software from customer premises equipment through to DCC, suppliers, network operators and other Authorised Parties.
Teleswitching Service	The legacy arrangement whereby a supplier provides the customer with a service that has the capability of switching on and off loads such as space and water heating. This is provided via a time-switch or radio teleswitch device that also controls which legacy consumption register is used at any time.
Threshold	The point at which a limit (voltage, current, etc.) is perceived as valid, achieved or exceeded+B114
Tier	A means of charging differing amounts for energy consumed, based on the quantity of energy consumed (i.e. the first 100 units to be charged at x pence, the next 500 units to be charged at y pence).
Time Change	Adjustment to the SMS clock value by a configurable amount.
Time Change Offset	The specific time offset (in hours) to be applied the SMS clock value.
Time of Use (ToU)	A multi-rate pricing arrangement where the energy price rate applied at any instant depends on the time of day. NB: With the meter operating on UTC this will necessitate for BST adjustment for time as displayed on the meter, and when the rate changes, when the clocks change.
TPR	Time Pattern Regime (codes that determine the switching pattern that defines when registers measure consumption).
Traffic	Data transmitted over a network. Traffic is a very general term and typically refers to overall network usage at a given moment. However, it can refer to specific transactions, messages, records or users in any kind of data network.
Transit	Data or Information passing through DCC systems that relates to communication between equipment located at the consumer's premises and an Energy Supplier, Network Operator or other DCC User.
Type of Day	A multi-rate pricing arrangement where the energy price applied at any instant in time depends on the day of the week, scheduled holiday or special event days etc.

Term	Definition
UTC	Coordinated Universal Time formerly known as GMT.
Utility Robust	The Smart Metering equipment components shall not rely on systems or services that are owned or operated by third parties, including consumers, where there is no specific provision to ensure the availability of such systems or services.
UTRN	Unique Transaction Reference Number. A number used to identify a financial transfer such that duplication of the transfer is impossible.
Valve	Component of the gas meter that when activated interrupts supply into the premises (this is not the Emergency Control Valve).
Valve Closure	Valve closure is the act that puts a Valve in a state where the flow of gas is not allowed.
Vend Code	Encrypted numeric code used to transfer a payment to meter.
WAN	Wide Area Network. The Smart Metering WAN will be used for two-way communication between Smart Meters and DCC (via the WAN communications module in the customer's premises).
WAN Enabled Technology	A device that supports the WAN provision / provides the WAN connection.
WAN Interface	An interface that allows a network device such as a router to connect and transmit data over a Wide Area Network.
WAN Technology	Technology associated with the WAN.
Wake up	To activate from a dormant or inactive condition. This can be triggered remotely or locally. gas meter specific.
Wake up schedule	The default period of which the gas meter wakes up, for example every 30 minutes.
Week Profile	A configuration of switching times, tariff prices and prepayment settings.
WELMEC	Western European Legal Metrology Cooperation: an organisation of legal metrologists.
White List	A white list is a list or register of entities that, for one reason or another, are being provided a particular privilege, service, mobility, access or recognition.
Z	Compressibility. Value that expresses the variation of real gas properties from the ideal gas law. For meters operating on a typical gas metering pressure of 21 mbar, this value is taken to be 1.

Appendix B: Normative References

Normative References

1.1. These are grouped into sections and an explanation of the columns and content for the tables is shown below.

Technical Specification Reference	Standards Reference	Title	Specific Clause	Governing Body	Status
<i>To ESoDR or other requirement</i>	<i>No. of the standard</i>	<i>The title of the Reference</i>	<i>As needed</i>	<i>The body responsible for the Reference</i>	<i>Whether Published or Draft, and a date</i>

Directive Harmonisation

1.2. The table below shows a number of key European Harmonisation Directives that apply to Smart Metering and Smart Metering components.

1.3. Where necessary, a reference to the technical specification is included, and explanatory notes are used.

Directive Reference	Technical Specification Reference	Specific Clause(s)
Measuring Instruments Directive (MID) – 2004/22/EC	ESoDR	Enacted in the UK as The Measuring Instruments (Active Electrical Energy Meters) Regulations SI 2006:1679 The Measuring Instruments (gas meters) Regulations SI 2006: 2647
Radio and Telecommunications Terminal Equipment (R&TTE) Directive - 1999/5/EC	HA.22 – Co-existence	Assumed that WAN standards that comply with EU requirements also meet R&TTE requirements
Electromagnetic Compatibility (EMC) Directive – 2004/108/EC	A number of generic and product Standards for Emission and Immunity are applicable	Applies to all electrical equipment
Low Voltage Directive (LVD) – 2006/95/EC, BS1363, Electrical Equipment (Safety) Regulations 1994, Electromagnetic Compatibility (EMC) Directive – 2004/108/EC, EN 60950-1, BS EN 60529 (IP Code)	IH.1 – Mains Powered IHD	Assumed to apply to any other electrical equipment used to support the Smart Meter network, but not the meters themselves
Battery Directive – 2006/66/EC	Battery related requirements - IM.7, GS.8	Directive focus is on the manufacture and disposal of batteries – assumed to apply to gas meter battery in particular. Sealing arrangement to comply with MID requirements
Restriction of Hazardous Substances (RoHS) Directive – 2002/95/EC	IM.12 – Public Safety	Applies to general public safety and the safety of those working with meters
Waste Electrical & Electronic Equipment (WEEE) – 2002/96/EC	No specific reference	Meters themselves are exempt, but other equipment, particularly IHDs, may be subject to disposal requirements
The Welsh language (Wales) measure 2011	DS.8	

Meters

1.4. Relates to the design, construction and operation of gas or/and electricity meters.

Technical Specification Reference	Standards Reference	Title	Specific Clause	Governing Body	Status
ESoDR General for Electricity IM.1 Base electricity meter specification	BS7856, Siemens Norm sn29500 – relating to electricity meter reliability	Code of Practice for design of alternating current, watt-hour meters for active energy (classes 1&2)	All	BSI	Due to be updated 2011
ESoDR General for Gas IM.1	BS6400 (parts 1-3)	Specification for Installation, Exchange, Relocation and Removal of gas meters with a maximum capacity not exceeding 6 m ³ /h	All	BSI	
ESoDR OP.5, ES.13 – Clock Accuracy	EN 62054-21	Electricity Metering Equipment (a.c.) Tariff & Load Control. Particular Requirements for Time Switches		CENELEC	Current
ESoDR OP.5 – Clock Accuracy ES.6, ES.7. ES.8, ES.9, ES.10 – Half Hourly Intervals GS.3 – Gas Intervals	The following as appropriate: WELMEC 11.2 Issue 1, Measuring Instruments Directive, BS EN 50470-1, BS EN 50470-3, EN 62053-23, BS EN 50160	Guideline on time depending consumption measures for billing purposes (interval metering)	All	WELMEC	Current

Technical Specification Reference	Standards Reference	Title	Specific Clause	Governing Body	Status
ESoDR OP.8, PC.1, PC.2, PC.3, PC.4, PC.5, PC.10, PC.11, ES.1, ES.12 Contactor & Use of Contactor ⁶	EN 62055-31	Electricity Metering – Payment Systems Part 31: Particular Requirements – Static Payment Meters for Active Energy (Classes 1&2)	Section 3.5 Section 7.9 Annex C	IEC	Current
ESoDR ES.1, ES.12 Contactor & Use of Contactor	EN 62052-11	Electricity metering equipment (AC) - General requirements, tests and test conditions - Part 11: Metering equipment		IEC	Current
ESoDR ES.1, ES.12 Contactor & Use of Contactor	EN 62053-21	Electricity metering equipment (a.c.). Particular requirements. Static meters for active energy (classes 1 and 2)		IEC	Current
ESoDR ES.1, ES.12 Contactor & Use of Contactor	EN 62054-21	Electricity metering (a.c.) Tariff and load control Part 21		IEC	Current
ESoDR ES.1, ES.12 Contactor & Use of Contactor	EN 60947-3	Low-voltage switchgear and controlgear. Switches, disconnectors, switch-disconnectors and fuse-combination units		IEC	Current

⁶ See 7.2.3 below for a recommended action

Technical Specification Reference	Standards Reference	Title	Specific Clause	Governing Body	Status
ESoDR ES.2 Measurement of Import, DI.4 Storage of configuration data	Measuring Instruments Directive BS EN 50470-1, BS EN 50470-3	The Measuring Instruments (Active Electrical Energy Meters) Regulations SI 2006:1679		Ofgem	Published
ESoDR ES.2 Measurement of Import	EN 50470-1	Electricity metering equipment (a.c.). General requirements, tests and test conditions. Metering equipment (class indexes A, B and C)		CENELEC	Current
ESoDR ES.3 Measurement of Export ⁷	Measuring Instruments Directive, BS EN 50470-1, BS EN 50470-3	The Measuring Instruments (Active Electrical Energy Meters) Regulations SI 2006:1679		Ofgem	Published
ESoDR ES.4, ES.5, ES.8, ES.9 – Reactive power measurement	EN 62053-23, BS EN 50470-1	Electricity metering equipment (a.c.). Particular requirements. Static meters for reactive energy (classes 2 and 3)		IEC	Current
ESoDR – IM.4 – Resume operation after failure in electrical supply (applies only to Electricity Meters)	Measuring Instruments Directive	The Measuring Instruments (Active Electrical Energy Meters) Regulations SI 2006:1679		Ofgem	Current

⁷ The MID applies to any meter used for charging purposes and so whilst currently there is no applicable standard, the WG believes the spirit of the MID should prevail.

Technical Specification Reference	Standards Reference	Title	Specific Clause	Governing Body	Status
ESoDR DS7 – Accessibility	GB Legislation	Electricity Supply Licence Gas Supply Licence	Condition 26	Ofgem	Published
ESoDR DS.7 – Accessibility	EU Council Decision 2010/48/EC	Social Measures for Target Groups – disability and old age	Entire Document	European Union	Published
ESoDR GS.1 – Gas Calculation Data	EN 12405-1:2005	gas meters. Conversion Devices. Volume Conversion		CEN	Current
ESoDR GS.2 – Gas Consumption	EN1359, EN14236, EN12480	gas meters (Diaphragm Meters), gas meters (Ultrasonic Meters), gas meters (Rotary Displacement Meters)		CEN for all	Current for all
ESoDR GS.5 – Valves GS.10 – Check for gas flow DI.6 – Battery status	prEN16314 (as specified in draft WI00237029 dated 04-02-2011)	Additional Functionalities Gas- Draft	Entire Document	CEN	Committee draft at time of writing
ESoDR IM.2 & OP.7 – Firmware upgrades	WELMEC 7.2	European cooperation in legal metrology Software Guide		WELMEC	Current

Components

Technical Specification Reference	Standards Reference	Title	Specific Clause	Governing Body	Status
Electricity Meter Variants – not required for new meters, but relevant for references to legacy solutions using teleswitches or telemeters	BS7647:1993	Specification for Radio Teleswitches for tariff and load control		BSI	Current
	BS7951:2000	Electricity meters. Alternating-current single-phase static watt-hour telemeters of accuracy class 1 or 2		BSI	
IHD Specification – IP rating	EN 60529	Specification for Degrees of Protection Provided by Enclosures		IEC	Current
IHD Specification – safety	EN 60950-1	Information Technology Equipment. Safety. General Requirements		CENELEC	Current
IHD Specification – EMC	EN 61000 – 4	Electromagnetic Compatibility (EMC). Testing and measurement techniques		IEC	Current
IHD Specification – Radio Interference	EN 55022	Information technology equipment. Radio disturbance characteristics. Limits and methods of measurement		CENELEC	Current
ESoDR Requirement IN.3 and OP.3	IETF RFC 4180	Common Format and MIME Type for Comma-Separated Value	All	IETF	Published
ESoDR Requirement OP.2	ITU-R TF.460	Standard Frequency and Time Signal Emissions		ITU	Published

Safety

1.5. Also note ESoDR requirement IM.12.

Technical Specification Reference	Standards Reference	Title	Specific Clause	Governing Body ⁸	Status
ESoDR IM.12 – Protecting Public Safety	GB Legislation	Electricity Act (1989), Gas Act (1986), and Energy Acts (2004)		Parliament	<i>In Force</i>
ESoDR IM.12 – Protecting Public Safety		Meter Asset Managers Code of Practice (Gas) – MAMCoP		MAMCoP	
ESoDR IM.12 – Protecting Public Safety		Gas Safety (Installation & Use) Regulations		MAMCoP	
ESoDR IM.12 – Protecting Public Safety		Gas Safety (Management) Regulations		MAMCoP	
ESoDR IM.12 – Protecting Public Safety		Codes of Practice (CoPs) for Ofgem Approved Meter Installers (OAMIs), COP/1a, COP/1b and COP/1c		MAMCoP	
ESoDR IM.12 – Protecting Public Safety		Health and Safety at Work etc. Act, 1974		MoCoPa	

⁸ A number of these references are to primary legislation, which are not governed by MAMCoP or MoCoPa, but these bodies administer them as activities for the Health and Safety Executive, or other government functions.

Technical Specification Reference	Standards Reference	Title	Specific Clause	Governing Body ⁸	Status
ESoDR IM.12 – Protecting Public Safety		Electricity at Work Regulations 1989		MoCoPa	
ESoDR IM.12 – Protecting Public Safety		Electricity Supply, Quality and Continuity Regulations 2002		MoCoPa	
ESoDR IM.12 – Protecting Public Safety	BS 7671	Requirements for Electrical Installations – also known as the <i>IEE Wiring Regulations</i>		JPEL/64	<i>Current</i>
ESoDR IM.12 – Protecting Public Safety	BS EN 50160	Voltage characteristics of Electricity Supplied by Public Electricity Networks		GEL/8	<i>Current</i>
ESoDR IM.12 – Protecting Public Safety		Meters (Certification) Regulations 1998		MoCoPa	
ESoDR IM.12 – Protecting Public Safety		Meters (Approval of Pattern or Construction and Method of Installation) Regulations 1990		MoCoPa	
ESoDR IM.12 – Protecting Public Safety		UK Regulations (various) supporting the Measurement Instruments Directive		Vary	
ESoDR IM.12 – Protecting Public Safety		The gas (meters) regulations 1983, SI 684 (as amended) or The Measuring Instruments (gas meters) regulations 2006, SI 2647			

Technical Specification Reference	Standards Reference	Title	Specific Clause	Governing Body ⁸	Status
ESoDR IM.12 – Protecting Public Safety	EN 50385	Product standard to demonstrate the compliances of radio base stations and fixed terminal stations for wireless telecommunication systems with the basic restrictions or the reference levels related to human exposure to radio frequency electromagnetic fields (110 MHz - 40 GHz)		CENELEC	Current
ESoDR IM.12 – Protecting Public Safety	NA	Guidelines for limiting exposure to time-varying electric, magnetic, and electromagnetic fields (up to 300 GHz) ICNIRP 1998 – as updated.		Published by the International Commission on Non-Ionizing Radiation Protection	Being updated

Environmental Standards

1.6. Over and above the relevant Directives listed in 6.1 above, there has been a general principle over recent years to ensure that all new, ongoing and revision work by standards committees takes account of environmental requirements and consequences.

Security

1.7. The following standards are referred to by the Security Requirements v0.3 (dated May 2011):

Security Requirements	Reference	Title	Specific Clause(s)	Governing Body	Status
SP.4 SP.23	FIPS-140-2	Security Requirements for Cryptographic Modules	NA	NIST	Published 2001

Security Requirements	Reference	Title	Specific Clause(s)	Governing Body	Status
SP.35 SP.36	BIP 0008	Evidential Weight and Legal Admissibility of Information Stored Electronically. Code of Practice for the Implementation of BS10008	NA	BSI	Published 2008
SP.35 SP.36	BIP 0009	Evidential Weight and Legal Admissibility of Electronic Information. Compliance Workbook for use with BS10008	NA	BSI	Published 2008

Application Layer Standards

1.8. There are a number of standardised application layers that could be used to meet the Smart Metering requirements. The table below describes those identified by the Application Layer Working Group in its working draft – this could be updated or amended as a result of their work.

Reference	Title	Governing Body	Status
IEC 62056 – 53/61/62	DLMS/COSEM	DLMS User Association	Published
EN 50090	KNX	KNX Association	Published
IEEE 1377	IEEE 1377	NIST	Published
EN13757	MBUS	CEN	Published
IEC 62056	SML	CENELEC	Published
EN 52056 or 52075	Smart Energy Profile 1.x	ZigBee Alliance	Draft

1.9. The following reference is to the use of an optical port to transfer data – this may or may not be relevant to the final specification as may be determined by the work of other groups considering options in this area.

Reference	Title	Governing Body	Status
IEC 62056-21	Direct Local Data Exchange	DLMS User Association	Published

WAN Communications

1.10. The requirement is for any WAN Communications solution used by the Smart Metering System to be a published standard. The European Standards Organisations have produced a Technical Report providing a list of relevant standards, entitled “Functional Reference Architecture for Smart Metering Systems”.

1.11. The table from the final version of this report, dated 30 May 2011, is shown below.

1.12. Section 8.2 – Existing Communications Standards & Standards to be developed under the Mandate.

Existing standards	TC	Standards to be developed	TC
General standards			
		EN/TR 5XXXX :201X Ed.1.0, <i>Electricity metering data exchange – Smart Metering standardization framework</i>	CLC TC 13
		EN/TR 5YYYY: 201X Ed.1.0, <i>Smart Metering use cases and functions</i> To be developed jointly by CEN TC 294, CENELEC TC13 and ETSI M2M	TBD
		EN 62056-1-0: 201X Ed. 1.0: <i>Electricity metering data exchange – The DLMS/COSEM suite – Part 1-0: Framework</i> (To be extracted from IEC 62056-53 Ed. 2.0:1996 and augmented)	IEC TC 13
		EN/TR 52056-1-1: 201X Ed.1.0, <i>Electricity metering data exchange – The DLMS/COSEM suite – Part 1-1: Mapping the use cases and functions to the COSEM data model</i>	CLC TC 13
		EN/TR 5ZZZZ-1: 201X Ed.1.0, <i>Electricity metering data exchange – The METERS and MORE suite – Part 1: Mapping the use cases and functions to the METERS and MORE data model</i>	CLC TC 13
EN 13757-1:2002 Ed. 1.0, <i>Communication systems for meters and remote reading of meters – Part 1: Data exchange</i> ⁹	TC 294	EN 13757-1:2002 in revision	TC 294

⁹ EN 13757-1 is a frame standard established by CEN/TC 294 for *Communication system for meters and remote reading of meters* (non-electricity).

This standard is referencing other parts of EN 13757 series and standards from IEC/EN 62056 series (DLMS/COSEM), including local interfaces, lower and upper layers, data modelling.

EN-50090-3-1 Home and Building Electronic Systems – <i>Part 3-1: Aspects of Application – Introduction to the application structure</i>	CLC TC 205		
EN-50090-3-2 Home and Building Electronic Systems – <i>Part 3-2: Aspects of Application – User Process for HBES Class 1</i>	CLC TC 205		
EN-50090-3-3 Home and Building Electronic Systems – <i>Part 3-3: Aspects of Application – HBES Interworking model and common HBES data types</i>	CLC TC 205		
		<i>prTR 50xxx: Smart Metering – Smart Metering/Smart Grid - HBES architecture and use of standardised communication</i>	CLC TC 205
ETSI TR 187 002 V2.1.1 " <i>TISPAN NGN Security (NGN_SEC); Threat, Vulnerability and Risk Analysis</i> " ETSI TS 187 001 V2.1.1 " <i>TISPAN NGN Security (NGN Sec): Security Requirements</i> " ETSI TS 187 003 V2.1.1 " <i>TISPAN NGN Security (NGN Sec): Security Architecture</i> " ¹⁰	ETSI		
EN 14908: <i>Open Data Communication in Building Automation, Controls and Building Management – Control Network Protocol</i>	CEN TC 247		
<u>Public Cellular Mobile Network</u> (GSM/GPRS/EDGE/UMTS) Smart Card Platform for mobile communication systems of 2G, 3G and beyond: - ETSI TS 102 221: <i>Smart Cards; UICC-Terminal interface; Physical and logical characteristics</i> - ETSI TS 102 223: <i>Smart Cards; Card Application Toolkit (CAT)</i> - ETSI TS 102 671 (under development): <i>Smartcards; Machine to Machine UICC; Physical and logical characteristics</i> - ETSI TS 102 225: <i>Smart Cards; Secured packet structure for UICC based applications</i> - ETSI TS 102 484: <i>Smart Cards; Secure channel between a UICC and an end-point terminal</i>	ETSI		

¹⁰ Note: ETSI TC TISPAN has developed the TVRA (Threat, Vulnerability, Risk Analysis) methodology and a set of guidance documents. The TVRA is currently used in ETSI TC TISPAN to derive security requirements and detailed security requirements. In TISPAN, the TVRA has been used to identify security requirements and countermeasure frameworks for IPTV, RACS, NAT, media security, and CPN. For more information on the TVRA, please see <http://portal.etsi.org/mbs/Security/writing/TVRA.htm>

<p><u>3GPP</u></p> <p>All the technologies currently specified by 3GPP (GERAN, UTRAN, LTE, LTE Advanced Access Networks, CS, GPRS and EPC Core Networks, IMS Subsystem) are relevant in the context of the M2M services, including specifically the SM services.</p> <p>These technologies can be referenced by means of the following "umbrella" specifications:</p> <ul style="list-style-type: none"> - TS 41.101 - TS 21.101 - TS 21.201 - TS 21.202 	<p>ETSI</p>		
--	-------------	--	--

<p><u>ETSI TISPAN</u></p> <p><u>Identifiers and Personalisation</u></p> <ul style="list-style-type: none"> - ETSI TS 184 002 V1.1.1 "Identifiers (IDs) for NGN" <p><u>Identity Management and Privacy</u></p> <ul style="list-style-type: none"> - ETSI TR 187 010 V2.1.1 Telecommunications and Internet converged Services and Protocols for Advanced Networking (TISPAN);NGN Security; Report on issues related to security in identity management and their resolution in the NGN <p><u>Customer Networks Architecture and connection to the NGN</u></p> <p>Customer IMS endpoints are connected to the NGN according to ETSI TS 122 228 (see below) or customer networks can be connected as in the following references:</p> <ul style="list-style-type: none"> - ETSI TS 185 005 V2.0.0 "<i>Services requirements and capabilities for customer networks connected to TISPAN NGN</i>" - Draft ETSI TS 185 003 V2.2.4 "<i>TISPAN Customer Network Gateway (CNG) Architecture and Reference Points</i>" - ETSI TS 185 006 V2.1.2 "<i>Customer Devices architecture and Reference Points</i>" <p><u>NGN Communication Link and Service requirements</u></p> <ul style="list-style-type: none"> - ETSI TS 181 005 v3 "<i>Service and Capability Requirements</i>" - ETSI TS 122 228 v.8.6.0 "<i>IMS Service requirements for the Internet Protocol (IP) multimedia core network subsystem (IMS);Stage 1</i>" - ETSI TS 122 173 V8.7.0 "<i>IMS Multimedia Telephony Service and supplementary services; Stage 1</i>" - ETSI TS 123 228 V8.12.0 "<i>IP Multimedia Subsystem (IMS); Stage 2</i>" - ETSI TS 124 229 V8,12.0 "<i>IP multimedia call control protocol based on Session Initiation Protocol (SIP) and Session Description Protocol (SDP); Stage 3</i>" 	<p>ETSI</p>	
--	-------------	--

<p><u>Public Switched Telephone Network (PSTN)</u></p> <p>Note: <i>it is hard to provide any list of Specifications on PSTN as they differ in each national implementation. We may say that all European PSTNs support G.711 (PCM of voice frequencies as a common denominator. G.711 should be able to fulfil the requirements of all data modem connections of the V-series. It should also be considered that multiplexing is not part of the usual capability).</i></p>			
<p><u>Integrated Service Digital Network (ISDN)</u></p> <p>Note: <i>Most European networks conform to the ISDN NNI Standard EN 300 356 (European ISUP version 4) which however requires an external IP-interface/gateway, so TISPAN does not intend to consider ISDN communication links within this document. There is a defined standard for ISDN Services at the User Interface (DSS1) EN 300 665. Whilst ubiquitously deployed in some Member States; these services are not available at the majority Accesses in all EU Member States. However, for completeness please note:</i></p> <ul style="list-style-type: none"> - EN 300 356-1 Version 4.2.1 <i>Integrated Services Digital Network (ISDN);</i> - Signalling System No.7 (SS7); <i>ISDN User Part (ISUP) version 4 for the international interface; Part 1: Basic services [ITU-T Recommendations Q.761 to Q.764 (1999) modified]</i> - EN 300 403-1 Version 1.3.2 <i>Integrated Services Digital Network (ISDN); Digital Subscriber Signalling System No. one (DSS1) protocol; Signalling network layer for circuit-mode basic call control; Part 1: Protocol specification [ITU-T Recommendation Q.931 (1993), modified]</i> 			

<p><u>Conformance with EMC and radio standards</u></p> <p>There is a series of general EMC and radio standards to demonstrate conformity with the R&TTE Directive (1999/5/EC) articles 3.1b and 3.2 respectively, which are relevant to situations where wireless communication is used; these are listed below.</p> <p><u>Harmonised standards to demonstrate conformity with the R&TTE Directive (1999/5/EC) article 3.1b:</u></p> <ul style="list-style-type: none"> - ETSI EN 310 489-1: "<i>Electromagnetic compatibility and radio spectrum matters (ERM); Electromagnetic Compatibility (EMC) standards for radio equipment and services Part 1 Common technical requirements</i> - ETSI EN 310 489-1: "<i>Electromagnetic compatibility and radio spectrum matters (ERM); Electromagnetic Compatibility (EMC) standards for radio equipment and services Part 3 Specific conditions for Short Range devices (SRD) operating on frequencies between 9MHz and 40GHz</i> <p><u>Harmonised standards to demonstrate conformity with the R&TTE Directive (1999/5/EC) article 3.2:</u></p> <ul style="list-style-type: none"> - ETSI EN 300220-2 (v2.3.1): "<i>Electromagnetic compatibility and Radio spectrum Matters (ERM); Short Range Devices (SRD); Radio equipment to be used in the 25 MHz to 1 000MHz frequency range with power levels ranging up to 500 mW</i>" - ETSI EN 300440-2 (v1.4.1): "<i>Electromagnetic compatibility and Radio spectrum Matters (ERM); Short range devices; Radio equipment to be used in the 1 GHz to 40 GHz frequency range</i>" - ETSI EN 300328 (v1.7.1): "<i>Electromagnetic compatibility and Radio spectrum Matters (ERM); Wideband transmission systems; Data transmission equipment operating in the 2,4 GHz ISM band and using wide band modulation techniques</i>" - ETSI EN 302 065 (V1.2.1) (all parts): "<i>Electromagnetic compatibility and Radio spectrum Matters (ERM); Ultra WideBand (UWB) technologies for communication purposes; Harmonised EN covering the essential requirements of article 3.2 of the R&TTE Directive</i>" - ETSI EN 302 500 (V1.2.1) (all parts): "<i>Electromagnetic compatibility and Radio spectrum Matters (ERM); Short Range Devices (SRD) using Ultra WideBand (UWB) technology; Location tracking equipment in the frequency range from 6 GHz to 8,5GHz; Harmonised EN covering the essential requirements of article 3.2 of the R&TTE Directive</i>" 			
---	--	--	--

EN 50065-1:2001– <i>Signalling on low-voltage electrical installations in the frequency range 3 kHz to 148 kHz:</i>	CLC TC 205A		
---	-------------------	--	--

Lower layer standards			
EN 62056-31:1999 Ed. 1.0, <i>Electricity metering – Data exchange for meter reading, tariff and load control – Part 31: Use of local area networks on twisted pair with carrier signalling</i>	IEC TC 13	EN 62056-3-1:201X Ed.2.0 13/1461/CDV, <i>Electricity metering data exchange – The DLMS/COSEM suite –Part 3-1: Use of local area networks on twisted pair with carrier signalling</i>	IEC TC 13
EN 62056-42:2002 Ed. 1.0, <i>Electricity metering – Data exchange for meter reading, tariff and load control – Part 42: Physical layer services and procedures for connection-oriented asynchronous data exchange</i>	IEC TC 13		
EN 61334-5-1:2001 Ed. 2.0, <i>Distribution automation using distribution line carrier systems – Part 5-1: Lower layer profiles – The spread frequency shift keying (S-FSK) profile</i>	IEC TC 57		
EN 61334-4-32:1996 Ed. 1.0, <i>Distribution automation using distribution line carrier systems – Part 4: Data communication protocols – Section 32: Data link layer – Logical link control (LLC)</i>	IEC TC 57		
EN 61334-4-511:2000 Ed. 1.0: <i>Distribution automation using distribution line carrier systems – Part 4-511: Data communication protocols – Systems management – CIASE protocol</i>	IEC TC 57		
EN 61334-4-512:2002 Ed. 1.0: <i>Distribution automation using distribution line carrier systems – Part 4-512: Data communication protocols – System management using profile 61334-5-1 – Management Information Base (MIB)</i>	IEC TC 57		
		EN/TS 5V VVV-1:201X Ed.1.0, <i>Data exchange over power lines – Part 1: Lower layer profile using OFDM modulation Type 1</i> (Note: this is the PRIME specification)	CLC TC 13
		EN/TS 5V VVV-2:201X Ed.1.0, <i>Data exchange over power lines – Part 2: Lower layer profile using OFDM modulation Type 2</i> (Note: this is the G3 specification)	CLC TC 13
EN 62056-46:2007 Ed.1.1, <i>Electricity metering – Data exchange for meter reading, tariff and load control – Part 46: Data link layer using HDLC protocol</i>	IEC TC 13		

EN 62056-47:2007 Ed. 1.0, <i>Electricity metering – Data exchange for meter reading, tariff and load control – Part 47: COSEM transport layers for IPv4 networks</i>	IEC TC 13	EN 62056-4-7:2007 Ed. 1.0, Amd. 1: <i>Electricity metering data exchange – The DLMS/COSEM suite – Part 4-7: COSEM transport layers for IPv4 and IPv6 networks</i>	IEC TC 13
		EN/TS 5ZZZZ-4: 201X Ed.1.0, <i>Electricity metering data exchange –The METERS and MORE suite – Part 4: Lower layer profile using B-PSK modulation</i>	IEC TC 13
EN-50090-5-1 Home and Building Electronic Systems – <i>Part 5-1: Media and media dependent layers – Powerline for HBES class 1</i>	CLC TC 205		
EN-50090-5-2 Home and Building Electronic Systems – <i>Part 5-2: Media and media dependent layers – Network based on HBES Class 1, Twisted Pair</i>	CLC TC 205		
EN-50090-5-3 Home and Building Electronic Systems – <i>Part 5-3: Media and media dependent layers – Radio Frequency</i>	CLC TC 205		
EN 13321 series: Open data Communication in Building Automation, controls and building management – Home and building electronic system	CEN TC 247		
EN 14908 series: Open data Communication in Building Automation, Controls and Building Management – Control Network Protocol	CEN TC 247		
EN 13757-2:2004 <i>Communication systems for and remote reading of meters Part 2: Physical and Link Layer</i> <i>Note: twisted pair, base band signalling (M-Bus)</i>	CEN TC 294		
EN 13757-4:2004, <i>Communication systems for and remote reading of meters Part 4: Wireless meter readout</i>	CEN TC 294	EN 13757-4:2004 potential revision after feasibility study for new modes <i>A necessary revision of EN 13757-4 has started in TC294WG5, noting EEC decision 2005-928-CE relative to "ERMES" frequency band and its reallocation to metering, among other applications.</i>	CEN TC 294
EN 13757-5:2008, <i>Communication systems for and remote reading of meters Part 5: Wireless relaying</i>	CEN TC 294		
		ETSI TS 102887-1 Smart Metering wireless access protocol: part 1: Physical Layer	ETSI ERM
		ETSI TS 102887-2 Smart Metering wireless access protocol: part 2: Data Link Layer (MAC)	ETSI ERM

Upper layer standards			
EN 62056-53:2007 Ed.2.0, Electricity metering – Data exchange for meter reading, tariff and load control – Part 53: COSEM Application layer	IEC TC 13	EN 62056-5-3:201X Ed.3.0, Electricity metering data exchange – The DLMS/COSEM suite – Part 5-3: COSEM Application layer	IEC TC 13
EN 50090-4-1 Home and Building Electronic Systems – <i>Part 4.1:Media Independent Layers – Application layer for HBES Class 1</i>	CLC TC 205		
EN 50090-4-2 Home and Building Electronic Systems – <i>Part 4.2:Media Independent Layers – Transport layer, network layer and general parts of data link layer for HBES Class 1</i>	CLC TC 205		
EN 50090-4-3 Home and Building Electronic Systems – <i>Part 4.3:Media Independent Layers – Communication over IP (EN 13321-2:2006)</i>	CLC TC 205		
EN 50090-7-1 Home and Building Electronic Systems – <i>Part 7.1:System management – Management procedures</i>	CLC TC 205		
EN 13321 series: Open data Communication in Building Automation, controls and building management – Home and building electronic system	CEN TC 247		
EN 14908 series: Open data Communication in Building Automation, Controls and Building Management – Control Network Protocol	CEN TC 247		
EN 13757-3:2004 , Communication systems for and remote reading of meters Part 3: Dedicated application layer Note: (M-Bus)	294	EN 13757-3: 2004 in revision	294
		EN 62056-5-8:201X Ed.1.0, Electricity metering data exchange – The DLMS/COSEM suite – Part 5-8: SML container services	IEC TC 13
		EN/TS 5ZZZZ-5: 201X Ed.1.0, Electricity metering data exchange – The METERS and MORE suite – Part 5: Application layer	CLC TC 13

Data model standards			
EN 62056-61: 2006 Ed. 2.0, Electricity metering - Data exchange for meter reading, tariff and load control - Part 61: Object identification system (OBIS)	IEC TC 13	EN 62056-6-1: 201X Ed. 3.0, Electricity metering data exchange – The DLMS/COSEM suite – Part 6-1: Object identification system (OBIS)	IEC TC 13
EN 62056-62:2006 Ed. 2.0, Electricity metering - Data exchange for meter reading, tariff and load control - Part 62: Interface classes	IEC TC 13	EN 62056-6-2:201X Ed. 3.0, Electricity metering data exchange – The DLMS/COSEM suite – Part 6-2: COSEM interface classes	IEC TC 13

		EN/TS 5ZZZZ-6: 201X Ed.1.0, Electricity metering data exchange – The METERS and MORE suite –Part 6: Data model	CLC TC 13
EN 50090-3-3 Home and Building Electronic Systems (HBES): <i>Part 3.3: Aspects of application – HBES Interworking model and common HBES data types</i>	CLC TC 205		
		TR50xxx: Smart Metering – Application Specification – Display	CLC TC 205
		TR50xxx: Smart Metering – Application Specification – Additional Services	CLC TC 205
EN 13321 series: Open data Communication in Building Automation, controls and building management – Home and building electronic system	CEN TC 247		
EN 14908 series: Open data Communication in Building Automation, Controls and Building Management – Control Network Protocol	CEN TC 247		
EN 13757-3:2004, Communication systems for and remote reading of meters Part 3: Dedicated application layer Note: (M-Bus)	294	EN 13757-3: 2004 in revision	294
IEEE-1377 (1997): Utility Industry Metering Communication Protocol Application Layer (End Device Data Tables)	-		-

Communication profile standards			
		EN 62056-7-1:201X Ed.1.0, Electricity metering data exchange – The DLMS/COSEM suite – Part 7-1: Communication profile for twisted pair local networks using carrier signalling	IEC TC 13
		EN/TS 52056-7-2: 201X Ed.1.0, Electricity metering data exchange – The DLMS/COSEM suite – Part 7-2: Communication profile for twisted pair local networks using baseband signalling (M-Bus)	CLC TC 13
		EN/TS 52056-7-3: 201X Ed.1.0, Electricity metering data exchange – The DLMS/COSEM suite – Part 7-3: Communication profile for wireless local networks (wireless M-Bus)	CLC TC 13

		EN 62056-7-6: 201X Ed.1.0, Electricity metering data exchange – The DLMS/COSEM suite – Part 7-6: The 3-layer, connection oriented, HDLC based communication profile (To be extracted from EN 62056-53 Ed. 2.0)	IEC TC 13
		EN/TS 5ZZZZ-7: 201X Ed.1.0, Data exchange for electricity metering – The METERS and MORE suite – Part 7: Communication profile for power line carrier local networks	CLC TC 13
		EN 62056-8-3:201X Ed.1.0, Electricity metering data exchange – The DLMS/COSEM suite – Part 8-3: Communication profile for power line carrier neighbourhood networks using S-FSK modulation	IEC TC 13
		EN/TS 52056-8-4: 201X Ed.1.0, Electricity metering data exchange – The DLMS/COSEM suite – Part 8-4: Communication profile for power line carrier neighbourhood networks using OFDM modulation Type 1 (Note: This is the PLC PRIME communication profile)	CLC TC 13
		EN/TS 52056-8-5: 201X Ed.1.0, Electricity metering data exchange – The DLMS/COSEM suite – Part 8-5: Communication profile for power line carrier neighbourhood networks using OFDM modulation Type 2 (Note This is the PLC G3 communication profile)	CLC TC 13
		EN/TS 5ZZZZ-8: 201X Ed.1.0, Electricity metering data exchange for – The METERS and MORE suite – Part 8: Communication profile for power line carrier neighbourhood networks using B-PSK modulation	CLC TC 13
		EN 62056-9-7:201X Ed.1.0, Electricity metering data exchange – The DLMS/COSEM suite – Part 9-7: Communication profile for TCP-UDP/IP networks	IEC TC 13
		EN 62056-9-8:201X Ed.1.0, Electricity metering data exchange – The DLMS/COSEM suite Part 9-8: Communication profile using SML services	IEC TC 13
		EN/TS 5ZZZZ-9: 201X Ed.1.0, Electricity metering data – The METERS and MORE suite – Part 9: Communication profile for TCP/IPv4 networks	CLC TC 13

HAN Communications

Technical Specification Reference	Standards Reference	Title	Specific Clause	Governing Body	Status
WA.1 WAN Interface	Referencing IFRS CWA 50560, as appropriate				
ESoDR HA.5 Testing for Interoperability WA.4 Testing for Interoperability	The following as appropriate: IEC 17011, 17025, 17043	Conformity assessment -- General requirements for accreditation bodies accrediting conformity assessment bodies		ISO/IEC	Current
ESoDR HA.5 Testing for Interoperability WA.4 Testing for Interoperability	IEC 17025	General requirements for the competence of testing and calibration laboratories		ISO/IEC	Current
ESoDR HA.5 Testing for Interoperability WA.4 Testing for Interoperability	IEC 17043	Conformity assessment – General requirements for proficiency testing		ISO/IEC	Current

Interoperability Standards

Technical Specification Reference	Standards Reference	Title	Specific Clause	Governing Body	Status
Interoperability Principles	CWA50560:2010	IFRS – Interoperability Framework Requirements Specification	Entire Document	CENELEC	Current

Recommendations & Next Steps

1.13. This section provides guidance from the working group on the status of individual or collected standards – i.e. the adoption of a Committee Draft pending formal acceptance.

Ongoing GB Standards Activity

1.14. The following areas have been highlighted as areas of particular interest to the development of Smart Metering equipment and practices in GB.

1.15. The Programme and/or industry needs to maintain a watching brief, and in some cases, an influencing brief, on these issues to make sure that the SMDG design requirements for Smart Metering are supported by standards.

Sealing Standards

1.16. Currently, there is documentary guidance from WELMEC (guide 11.3) on sealing metrological devices. The Working Group considers that these principles could and should be applied to other relevant areas of the metering system;

- Electricity meters
- Gas meters
- Communications Hubs
- Any modular design feature, such as a WAN Communications module chamber
- Replaceable components – such as a battery chamber.

Product Safety Standards

1.17. Whilst it is clear which standards apply to gas and electricity metering products, and also to IHD products, it is not clear which product safety standards should apply to the proposed Communications Hub.

1.18. This is further compounded by the architectural options; under variant 1 or 2, where the Communications hardware is enclosed/embedded with metrology, this should be covered by the product safety standards applied to the overall Smart Meter.

1.19. For the main variant, with a separate Communications Hub, there has been considerable correspondence and discussion about the most appropriate Product Safety standard, each of which carries particular implications to the physical design and the component makeup of these new products.

1.20. IEC TC13 and IEC TC66 both discuss the potential options in this area, and GB should continue to monitor developments to ensure that the specification is appropriate. At present, no single standard is understood to apply to this new class of equipment – communications for metering purposes. In light of this, it is perfectly acceptable for Suppliers and Manufacturers to determine collectively or bilaterally which is the most appropriate and applicable standard;

- EN 61010 – Safety Requirements for electrical equipment for measurement, control, and laboratory use. *This may result in a requirement for an isolation switch to be included and accessible in a Communications Hub*
- EN 60950 – Information Technology Equipment – Safety. *The group concluded that this could result in earthing or fuse requirements being placed on Communications Hub equipment*
- IEC 62052-31. Electricity metering equipment (AC) - General requirements, tests and test conditions - Part 31: Safety requirements. *This is part of the standards suite that protects metering equipment presently.*

Contactor and Switch References

1.21. The Normative References WG discussed the fact that there are five standards listed in 6.2, above, relating to contactors and switches in electricity meters. It was noted that further work should be done to examine these standards to make sure they are all necessary, and that they are all relevant in a Smart Metering context.¹¹

1.22. Given that they are required to perform a prepayment meter function, Smart Meters clearly need to be governed by a pre-payment meter standard. However the only standard available at present is IEC 62055-31 which, in its current form, relates only to meters of accuracy class 1 & 2. Clearly this standard needs to be updated to reflect measurement classes arising from the MID i.e. classes A, B and possibly C. It is assumed that BSi will be undertaking this task.

GB/UK Industry Standards

1.23. The Normative References WG considered a suggestion to include other applicable requirements from GB licensed governance – such as the Codes of Practice for metering within the Electricity Balancing and Settlement Code.

¹¹ It was agreed to investigate this area with the relevant BSI committee and within the relevant trade associations.

1.24. The group was of the view that this could be an unnecessary step, as these requirements apply in the context to which they apply only, and are National standards, with no European equivalent or context.

Erasure of Data Stored Locally

1.25. It is understood that there are ongoing discussions within WELMEC that could provide guidance in this area. Developments in this area should be monitored for any publication from WELMEC that could support requirement DS.6 – support erasure of data stored locally.

Electromagnetic Immunity for Meters

1.26. An issue raised by the Swedish standards body, Swedac, relating to potential impact on meter accuracy as a result of noise generated in the 3 to 150KHz range, remains outstanding. This issue can occur through the use of switched-mode power supplies associated with the use of micro-generation units and air source heat pumps. IEC TC13 is currently looking into this issue.

1.27. The industry, through manufacturers' associations and standards committees, is seeking to tighten the relevant standards to ensure that meters are tested to prove they are suitable for use in such environments. This should result in an update to the EN 50470 standard that is already listed in the tables above.

Appendix C: HAN Evaluation Criteria

1.28. This appendix presents additional technical and commercial criteria to support and inform the ESoDR HAN requirements. These criteria have been written to allow the Programme or Industry to use them to support any future selection or evaluation exercise for candidate HAN technologies.

Convention

1.29. The table below uses the following column headings

- **Ref** – a unique reference number for the criteria, these are not sequential but will be reorganized prior to publication of the final draft set of criteria
- **Criteria** – a description of the individual criteria
- **Wired & Wireless** – a number of criteria will only apply to radio or wired solutions¹²
- **ESoDR/Security** – reference to a Programme document containing requirements. e.g. S.HAN.02 for the security requirements, or ES.11 for the ESoDR
- **Expectation** – what do the HAN WG anticipate as being an indicator of compliance with the criteria – can include any comments or expectations of test

1.30. As a general principle, all criteria, as appropriate, should state either;

- ‘under normal operating circumstances’, or
- ‘typical usage’ etc.

Evaluation Criteria

Ref	Criteria	Wired & Wireless	ESoDR/ Security	Expectation
General & ESoDR Requirements				
1.1	Under normal operating circumstances, there is no expectation for customers to take any action to maintain the operation of the SM HAN ¹³	Both	IM.04 OP.01	Is mainly a product characteristic and is expected to be resolved through development of the market Test through written questions Qualitative results are expected
1.2	The SM HAN should not add unnecessary complexity or time to commissioning, binding or pairing devices	Both	IM.11	Security Requirements will have a bearing here Product characteristic

¹² An assumption to note here is that wired in a HAN context is expected to be a power line based technology. The use of dedicated wiring is expected to be very limited

¹³ This is for technical operations – Customers are expected to interact with the HAN to pair/bind new devices

Ref	Criteria	Wired & Wireless	ESoDR/ Security	Expectation
				Test through written questions Qualitative results Expectation that SM HAN contributes less than 10 seconds to overall process
1.3	Minimise number of site visits and customer calls to address SM HAN issues	Both		Depends on quality of product Test through evidence from other relevant deployments
1.4	Percentage of GB homes covered by this solution with no additional equipment	Both		Test through written questions and evidence based responses Derive coverage from other tests and known parameters (e.g. building stock, construction types, meter locations) Linked to deliverable from Difficult Meter Positions WG
1.5	Physical dimensions for SM HAN solution components to be suitable for use in metering and related products and the environmental conditions in which these are expected to operate.	Both		Test through provision of reference design/schematic Circuit board and antenna (for wireless)
Interoperability				
2.1	Is an Open Standard as defined by the European Union, or can demonstrate a clear path to approval as an Open Standard	Both	HA.01 IN.03	See below for definition of an open standard Request statement of compliance or planned compliance (including timed delivery)
2.2	Genuine choice and competition between silicon vendors	Both		Expect a minimum of three independent silicon vendors, although other approaches could be considered if criteria 2.1 is demonstrated Test through provision of a statement of compliance
2.3	Interoperable solutions from a minimum of three providers can be tested today ¹⁴	Both	HA.05	Today – is at the point of undertaking the testing

¹⁴ This criteria will be tested non-technically for 'pre-qualification', but will also form part of the technical evaluation to provide additional assurance of a critical requirement

Ref	Criteria	Wired & Wireless	ESoDR/ Security	Expectation
				Non-technical test is the availability of products to test Technical test will, where possible, link three chips (from different providers) together to demonstrate the most basic interoperability
2.4	Support for a minimum of 8 HAN Devices in a network ¹⁵	Both	HA.19	Non-technical test to be a request of proof of compliance within the specification Non-technical to demonstrate maximum number of devices in a practical implementation ¹⁶
2.5	Support for suitable SM HAN Application Profiles	Both	HA.07 HA.15 IN.03 OP.02	Request details of support
Power				
3.1	Power : 'active'	Both	IH.02 OP.04	Current consumption, in Joules while transmitting one secured half hourly read of usage data from a meter
3.2	Power : 'peak'	Both	IH.02 OP.04	Peak current, in milliamps (mA), during a transmission ¹⁷
3.3	Power : 'dormant'	Wireless	IH.02 OP.04	Current consumed, in micro Amps (uA), while the HAN solution is inactive / asleep awaiting the next transmission event
3.4	Support for battery powered nodes (i.e. have an ability to go into a 'sleep' mode)	Wireless	GS.03 HA.11	Request for statement of compliance
Data Performance				
4.1a	Data Transmission Speed	Wireless	DS.2 HA.07	Time taken to transfer a block (/file) of 10KBytes of data from one device to another device 10 metres (in free space) apart (test to be done using the normal modulation used/specified by the standard) Also perform the test for 300Kbytes

¹⁵ This could be influenced by HAN WG options paper on scope of the HAN, but essentially provides for 2 Meters, 1 IHD, 1 Communications Hub and 4 other devices – repeaters, booster, micro-generation meters etc.

¹⁶ For enduring, product based testing, this should be considered for technical testing

¹⁷ Or milliWatts for Powerline technologies

Ref	Criteria	Wired & Wireless	ESoDR/ Security	Expectation
				of data
4.1b	Data Transmission Speed	Wired	DS.2 HA.07	Time taken to transfer a block (/file) of 10KBytes of data from one device to another device 10 metres apart (test to be done using the normal modulation used/specified by the standard) Also perform the test for 300Kbytes of data
4.2	Robustness	Both	ES.11 HA.09	To be tested by monitoring the level of success for transmitting a set number of standard messages. ¹⁸ To be completed for a number of test environments (see 5.3)
4.3	Supports Acknowledgement of packets and retries (not application)	Both		Request statement of compliance
Performance				
5.1a	Point to Point Range	Wireless		Physical point to point range (in metres) and link budget (in dB) of the radio in free space, tested with best in class radios used for the standard being tested, based on an example maximum 1% PER (Packet Error Rate), transmit power set within regulatory limits for that frequency/modulation and receive sensitivity and antenna reflecting normal commercial use of the radio in SM HAN.
5.1b	Point to Point Range	Wired		Performance is greater than or equal to a given threshold for a certain percentage of socket pairs in a room of "x" square metres. Based on maximum 1% PER (Packet Error Rate), transmit power set within regulatory limits for that frequency/modulation and receive sensitivity and antenna reflecting normal commercial use of the radio in SM HAN
5.2a	Point to Point Range	Wireless		As per 5.1a, but with tests conducted at an application level

¹⁸ For Example – simulate the transmission of 10,000 messages (or other suitable number to be agreed) in a standard environment – how many complete first time, how many retries are needed, how many messages never complete.

Ref	Criteria	Wired & Wireless	ESoDR/ Security	Expectation
				using a standard application profile to be used in SM HAN, thus accounting for standard network and application level mechanisms for improving robustness of message delivery and accepting x% (to be defined, might be 0) loss of application level messages.
5.2b	Point to Point Range	Wired		As per 5.1b, but with tests conducted at an application level using a standard application profile to be used in SM HAN, thus accounting for standard network and application level mechanisms for improving robustness of message delivery and accepting x% (to be defined, might be 0) loss of application level messages.
5.3	Defined set of tests in a variety of simulated radio location scenarios. Scenarios to be provided by Difficult Meter Positions Working Group	Both		Links to 1.4 Potential for some tests to be defined to cover post installation, temporary or permanent, environmental changes
5.4	Vulnerability to signal interference	Both		Request documentation to demonstrate compliance and techniques
5.5	Ability to cope with signal interference	Both		Can investigate with other products; - within license exempt bands for wireless - alternative PLC technologies in the same spectrum range for wired Technical tests to be defined to challenge solutions against known interferers
5.6	'Good Neighbour' test – the solution should not materially affect other networks	Both	HA.22	Technical tests to assess coexistence with: - Other SM HANs in neighbouring properties - Other HANs or other networks operating within premises
5.7	"Good Citizen" test – the solution should not materially affect other services	Both		Powerline solutions have potential to interfere with e.g. amateur radio and broadband services. Test should be devised with this in mind.
5.8	Provision of diagnostic information for SM HAN	Both		Request statement of compliance
Security Requirements				
6.1	To be added when available from Security Team		HA.02 HA.16 IM.10	

Ref	Criteria	Wired & Wireless	ESoDR/ Security	Expectation
Future Flexibility				
7.1	Support for upgrades of SM HAN firmware without direct physical connection	Both	HA.12 IM.02 OP.07	Request statement of compliance with criteria
7.2	Support for firmware upgrades in SM HAN Devices	Both		As above
7.3	Existing nodes/devices are not stranded as a result of upgrades to the solution	Both		Request statement of compliance of criteria and some test scenarios – recovery if device was not present when upgrade took place
7.4	Longevity of frequency – availability and usability	Wireless		Request statement of compliance of criteria
7.5	Longevity of solution technology	Both	HA.20	Request statement of compliance of criteria
Cost				
8.1	Typical bill of materials cost per SM HAN enabled device	Both		Request indicative costs based on a known volume
8.2	Total Cost of Ownership – including power consumption	Both		Request indicative cost against a specific scenario of service and usage
Technology Maturity				
9.1	Use in equivalent Smart Metering deployments	Both		Request data to identify and quantify implementation Request utility/manufacturer references
9.2	Use in analogous applications – home automation, micro generation etc.	Both		Request data to identify and quantify activities Request industry references
9.3	Clarity of development strategy	Both		Request for development roadmap to show potential significant changes and anticipated product lifecycles
9.4	Capacity in vendors to meet Smart Metering demands – minimum of 4 nodes per home	Both		Request statement of capacity 5 year deployment to 25 million homes
9.5	Availability of non-metering products that could be relevant to Smart Metering – e.g. thermostats, display devices	Both		Request data to identify and quantify products

Evaluation Questions

1.31. The following questions are recommended to be provided to representatives of candidate HAN solution technologies to inform any selection or evaluation process.

Evaluation Criteria Ref	Question
Q1.1(a)	Is your SM HAN solution easy to maintain? (i) Does your system include facilities for remote maintenance (e.g. an end-user "assistant" to allow consumers to solve simple problems)? (ii) Please describe any specific features of your solution that support your answer.
Q1.1(b)	Please explain: (i) How these maintenance features work (ii) How they have been used in existing products that have been rolled-out, for Smart Metering or other home related applications (iii) Please provide references of implemented systems being maintained using the above features
Q1.2	Is your SM HAN solution easy to commission? (i) Please provide an outline of your installation and commissioning process, including a description of the skills required to complete an installation and any pre-install configuration required prior to the installation visit (ii) Describe your approach to field upgrades (e.g. to add a new SM HAN device) and indicate whether appropriate upgrades can be carried out by the end user (iii) Please describe any features of your solution that support your answer.
Q1.3(a)	(i) Please describe your approach to system reliability and maintainability, stating calculated and measured MTBFs and MTTRs where appropriate for a typical SM HAN installation comprising four connected devices (ii) Please describe the specific features of your solution that increase the reliability of your networks and reduce support effort.
Q1.3(b)	(i) With reference to equivalent Smart Metering or home area networking deployments please provide data on site visits and customer calls required to maintain deployments. (ii) If appropriate please provide references for utility customers who may have this data.
Q1.4	(i) Please provide your assessment of the proportion of GB homes that could be covered by your HAN solution without a need for additional equipment (e.g. repeaters) (ii) Please provide evidence (references) to results of tests carried out in buildings representative of GB housing stock, including multi-occupancy dwellings. Note: A standard GB SM HAN installation will include an Electricity Meter, gas meter, In-Home Display and a Communications Hub (iii) Please describe which types of GB homes your solution could and couldn't cover (again without additional equipment) and explain the reasons. (iv) Please provide references to supporting material on other in-building tests which provide further evidence of your system's capability
Q1.5	(i) Please provide the physical dimensions (length, width, height) of a typical reference design or module that might reasonably be used in a SM HAN device. This should include all components necessary to operate the SM HAN communications, including antenna, microcontroller and radio. (ii) Please describe any specific implementations you may have for tamper-resistant antennas that may be mounted externally to a meter enclosure, including details of the increase in transmission range that they provide

Evaluation Criteria Ref	Question
Q2.1(a)	(i) Is your solution based on an Open Standard? (ii) Please provide evidence, including relevant standards references, or if you have a roadmap to become an Open Standard please explain the schedule and plan for this.
Q2.1(b)	Is the development of your standard managed by a not for profit organisation? If so, please identify the organisation and provide evidence of its status.
Q2.1(c)	Does your IPR policy include RAND licensing that can be availed of by anyone?
Q2.1(d)	Are your specifications available for everyone to study? Is there a cost involved? Please provide details of how to access your specifications.
Q2.1(e)	(i) What mechanism exists for stakeholders to contribute to the development of the specifications? (ii) Is there a requirement to become a member of an Alliance or equivalent, and if so, what is the cost? (iii) Is public review part of the decision-making process?
Q2.2(a)	How many different commercially available platforms support your SM HAN solution? Please list them including manufacturer's name and contact details (e.g. web site) and provide evidence of their commercial availability, or a roadmap for availability. Note: By "different", we mean that platforms use different silicon and software vendors/solutions in their designs
Q2.3(a)	(i) Please list the independent solutions available and provide evidence of the existence of at least 3 different interoperable solutions from 3 different providers, ideally publicly available and independently verifiable. (ii) Please explain how interoperability of different manufacturers' solutions is tested and verified (if this makes use of a Golden Unit, state who produces and maintains it)
Q2.3(b)	(i) What is the established certification process to assess conformance of products to your specifications? (ii) Please list the names and locations of independent test and certification laboratories that are set up to test products designed to your standard
Q2.4(a)	What is the maximum number of devices that can be connected in a single self-contained network using your solution? (i.e. without the use of gateways or bridges to connect separate subnets or networks)?
Q2.4(b)	(i) What is the recommended maximum number of devices in a single Smart Metering HAN using your solution? (ii) Please explain the characteristics of your solution that impact the maximum number of devices in a Smart Metering HAN.
Q2.5(a)	What Smart Metering HAN application profiles or protocols does your solution support? Please provide details including as appropriate links to appropriate standards and specifications.
Q2.5(b)	Please provide evidence of the use of your solution including the aforementioned application profile or protocols in other Smart Metering HAN deployments.
Q2.5(c)	Please provide evidence of how this application profile or protocol supports GB HAN requirements, including if applicable any roadmap.
Q3.1	For a typical SM HAN device using your solution, what is the expected energy consumption, in Joules, from wake up/activate to sleep/deactivate, to transmit one secured half hourly read of usage data from a meter? Note: Please specify what value the transmission power is set at to send this data (GB maximum regulatory limit or lower). If this response differs depending on individual implementations or environment/external conditions please explain the likely range of answers for different implementations.
Q3.2	For a typical SM HAN device using your solution, what is the expected peak current in milliamps (mA) during transmission of a packet of data?

Evaluation Criteria Ref	Question
	Note: Please specify under which reference voltage the solution is operating. If this response differs depending on individual implementations please explain the likely range of answers for different implementations.
Q3.3	For a typical SM HAN device using your solution, what is the current consumed, in micro Amps (uA), and the average active energy consumption, in Joules per hour while the HAN solution is inactive / asleep awaiting the next transmission event? Note: If this response differs depending on individual implementations please explain the likely range of answers for different implementations.
Q3.4	Does your solution support battery powered nodes? Please explain how. Please explain if the battery powered nodes have specific characteristics differing from mains powered nodes.
Q4.1(a)	What is the expected application data throughput for your solution in a point-to-point transmission? Note: Please include the overhead of any application or networking protocols, security and any acknowledgement mechanisms.
Q4.1(b)	What is the expected time taken to transfer a block (/file) of 10KBytes (Kilobytes) of Smart Metering data from one device to another device 10 metres (in free space) apart in the SM HAN? Note: Please state your assumptions concerning the overhead of signalling/control data that your system adds to the data payload before transmission
Q4.1(c)	What is the expected time taken to transfer a block (/file) of 300KBytes (Kilobytes) of Smart Metering data from one device to another device 10 metres (in free space) apart in the SM HAN? Note: Please state your assumptions concerning the overhead of signalling/control data that your system adds to the data payload before transmission
Q4.2(a)	Please describe all mechanisms used by your solution to ensure robust communications between devices, and refer to any case studies or evidence to show robustness of your solution. Note: Please list the mechanisms that apply at application, network and physical layers within your protocol and refer to specification documents as appropriate
Q5.1	(i) What is the expected point-to-point range of your radio in free space, based on maximum 1% PER (Packet Error Rate), transmit power set within EU regulatory limits for that frequency/modulation and receive sensitivity and antenna reflecting normal commercial use of the radio in SM HAN? (ii) Please provide evidence and results of independent testing in support of the range figures you quote
Q5.2	(i) Are there any mechanisms in your solution that would extend the point-to-point range beyond that normally expected by the physical medium (e.g. network retries to improve error rates, use of repeaters or range extenders)? (ii) Please explain how these mechanisms work and the measured impact that they have on operating range at a given BER
Q5.4	(i) Please identify any potential interferers with your solution and how they could impact communications. (ii) Please list and quantify the expected impact over the 15 year lifetime of the SM HAN system of: (a) co-channel (in-band) interferers (b) adjacent channel (out-of-band) interferers which exist or are expected to exist in GB homes over the system lifetime
Q5.5	(i) Please describe any mechanisms available to your solution for dealing with potential signal interference, with reference to appropriate specification or standards documents. (ii) Please outline your proposal for dealing with any SM HANs which fail in the field as a result of increasing levels of interference in your chosen frequency band

Evaluation Criteria Ref	Question
	from other services during the 15 year lifetime of the system
Q5.6	Please describe how your system design ensures that your solution does not interfere with or otherwise materially affect other networks or services using the same or different frequencies or physical media. Note: Please include in your analysis both existing networks and projections for future networks, where details are available
Q5.8	Please describe the information provided by your solution to assist with the diagnosis or analysis of SM HAN network connectivity and performance (e.g. signal strength, data error rate).
Q7.1a	(i) Does your solution support the upgrade of firmware on SM HAN devices without physically connecting to the device (e.g. using a radio link)? (ii) Please describe the mechanism and refer to any specifications or standards as appropriate. (iii) If your system does not support remote upgrade, please describe how upgrades are carried out and the effort involved in achieving this
Q7.1b	(i) If existing, please provide example of products (Smart Metering or home applications) that were actually upgraded on the field without manual intervention. (ii) Please describe the upgrade purpose, size, number of products affected, and any reference to the utility or customer of the product. Note: Where appropriate, please provide a reference to a utility that uses your system and can provide such data (on a confidential basis if necessary)
Q7.3	(i) Please describe the mechanisms in your solution for ensuring that existing nodes/devices in the Smart Metering HAN are not stranded as a result of a firmware upgrade. (ii) Please list separately the mechanisms for dealing with: (a) a network where devices may have more than one firmware version (b) a situation where a remote firmware upgrade fails on some or all devices
Q7.4	What is your expectation for the future availability and usability of the physical media (e.g. radio frequency) used by your solution? Your response should consider any likely threats and present arguments to support the continued use of your solution into the future.
Q7.5	(i) What is your expectation for the future availability of solutions and platforms? (ii) Please provide examples of (public domain) future product roadmaps from suppliers of your solution
Q8.1	What is the typical bill of material cost for a manufacturer to add your solution to a SM HAN device, inclusive of any microcontrollers required to run a networking stack and application protocols, transceivers, antenna, crystals etc.? Please consider a mains powered device (no battery needed). Note: Please use 1 million units as a base line for your answer and if there is likely to be a range of answers please provide this range and an explanation of what determines the lower and upper limits.
Q8.2(a)	Please provide your assessment of the total cost of ownership of your solution in an Electric meter over 15 years of usage, including initial BOM cost, ongoing power consumption, device/module replacement etc. Note: Please base your answer on an electric meter that is always available for real-time communications and which sends a packet of usage data every 5 seconds. You may assume the cost of energy remains constant at 10p per KWh during the lifetime of the system
Q8.2(b)	Please provide your assessment of the total cost of ownership of your solution in a Gas meter over 15 years of usage, including initial BOM cost, ongoing power consumption or battery replacement, device/module replacement etc. To simplify calculation, please consider that the battery consumption is dedicated to the HAN communications (i.e.: no Valve operations, no measurements microcontroller

Evaluation Criteria Ref	Question
	sharing the battery). Please base your answer on a Gas meter that communicates to send a packet of usage data every 30 minutes. You may assume the cost of energy remains constant at 10p per KWh during the lifetime of the system
Q9.1(a)	Please provide case studies or evidence of the use of your solution in equivalent Smart Metering deployments. Note: Where possible, please include references to numbers of devices and contact information at energy suppliers/utilities.
Q9.2	Is your solution applicable to analogous applications outside of the current SM HAN deployment? If so, please identify analogous markets where there has been significant usage of your solution, providing evidence in the form of case studies or references to manufacturers, product announcements etc.
Q9.3	Please provide a roadmap for your solution, clearly showing planned and ongoing major developments with timescales for completion.
Q9.4(a)	Please provide an estimate of how many nodes using your solution were shipped in 2009 and 2010.
Q9.4(b)	Please describe the impact on capacity for vendors of your solution should they have to deliver 100 million additional nodes for use in GB SM HAN deployments over approximately 5-6 years (from 2014 to 2019).

Evaluation Tests

1.32. The following tests are recommended to be carried out on suitable sample equipment provided by representatives of candidate HAN solution technologies to inform any selection or evaluation process.

1.33. To ensure that tests deliver the answers required it is proposed that the tests are based on the following principles:

- Tests should deliver results that are easily understood by non-technical people if at all possible. For example, it is preferable for testing to be performed using real SM HAN messages rather than test packets when performing tests on a radio.
- Tests should ideally be carried out using fully representative (deployable) products, except where the manipulation of the device required to perform that test makes this practically difficult.
- Where possible, all tests on radio performance should be performed using an ‘over-the-air’ connection (taking full account of any variations in antenna performance in different orientations). Performance measurements using wired (radio) connections should only be used where it is necessary to establish a base line or theoretical ideal.
- All tests of radio performance should be made using the agreed application profile and active network stack software (incorporating appropriate retry/retransmission mechanisms) to ensure tests are representative of performance in real SM HAN environments.
- Performance tests should use one of the following standard tests conditions:
 - ‘Nominal’ radio environment (no interference or multipath, nominal radio path loss), and

- ‘Challenging’ radio environment (representative interference and multipath, higher radio path loss)¹⁹
- Tests should be performed by an independent test house, supported by (but not influenced by) equipment suppliers.

Proposed test	Test	Evaluation Criteria Ref.	Proposed Tests	Notes
1	Interoperability	2.3	Perform interconnection tests between devices from different vendors	<p>Tests to be performed using full range of features and modes that are mandated to support SM HAN functionality.</p> <p>This is largely a software test activity conducted using the ‘nominal’ radio environment.</p> <p>If appropriate test equipment exists that can simulate other network elements, testing could be performed using this, based on defined test scripts. An alternative is the use of ‘Golden devices’</p>
2	Multi-device support	2.4	Perform a functional test using a network containing the maximum number of nodes	<p>Tests should ensure that all devices are communicating on the network, with representative data loading.</p> <p>Tested using the ‘Nominal’ radio environment.</p>
3	Power consumption	3.1 (‘Active’) 3.2 (‘Peak’) 3.3 (‘Dormant’)	Measure power consumption when network is operating in a representative mode	<p>Where evaluation is performed on an example radio module which is supported by (for example) an evaluation board, it shall be possible for the radio module to be decoupled from the evaluation board to allow power measurements of (just) the radio module to be made.</p> <p>Measuring the profile of the power consumption for completion of representative activities over a representative time cycle (e.g. 1 hour) would provide the clearest way of evaluating different technologies –</p>

¹⁹ Further work is required to define these environments. Although adding interfering sources to an over-the-air test is relatively easy, introducing representative multipath fading is much more difficult. Cabled (wired) tests may be required to separately assess the effect of multipath on the technologies being tested.

Proposed test	Test	Evaluation Criteria Ref.	Proposed Tests	Notes
				<p>this would show the variation in power over the full sleep-wake-transmit-sleep cycle. In addition it would highlight any peak current demands that are particularly relevant for gas meter battery applications.</p> <p>Tested using both the 'Nominal' and 'Challenging' radio environments.</p>
4	Data throughput	4.1 (data throughput), 4.2 (robustness)	Measure time taken to transfer a block (/file) of 10 kB and 300 kB of Smart Metering data from one device to another device, and perform data comparison to detect errors/lost packets etc.	<p>Tested using both the 'Nominal' and 'Challenging' radio environments – the latter would provide a good measure of system robustness.</p> <p>Tests should also be carried out at an 'application' or end product level to get information on real application data throughput with all protocols and overheads included</p>
5	Range	5.1, 5.2, 5.3	Physical point to point range of the radio in free space	<p>Tested using an interference- and multipath-free radio environment, with radio transmit power conforming to regulatory limits and receive sensitivity and antenna reflecting normal commercial use of the radio in SM HAN.</p> <p>Transmitter set to transmit test messages: 'Message Error Rate' (number of dropped application messages) measured for various equipment spacings²⁰. Full SM HAN application profile to be used to allow retransmissions (etc.).</p> <p>Range to be measured in free space (ideally directly outdoors), and in a number of representative building</p>

²⁰ The intention here would be to quantify performance vs. range and allow this to be plotted to allow different technologies to be assessed against each other

Proposed test	Test	Evaluation Criteria Ref.	Proposed Tests	Notes
				<p>environments.</p> <p>Range in free space should ideally be tested directly outdoors in a large open area, but if a suitable lab test is possible and proven to be accurate this could be used.</p> <p>It may be useful to record signal quality measurements such as LQI, RSSI.</p>
6	Immunity to interference	5.5	Functional and performance tests under different interference conditions	<p>These tests will use various 'challenging' radio environments to assess the impact of both 'co-channel' (in-band) and 'adjacent-channel' (out of band) interference on normal network operation.</p> <p>Interference scenarios to be based on likely 'real world' SM HAN environments, using real or simulated interference sources.</p> <p>Interference sources to include likely devices to be found in the home, including Wi-Fi networks, other 'HAN' type networks, microwave ovens, video senders, domestic entertainment devices and mobile devices (in various combinations). In addition, possible interference from sources outside the home environment (radio networks and other SM HAN networks, for example) will also be included.</p> <p>Sensitivity to interference from one type of interferer, and interferers acting together, to be investigated.</p> <p>Impact on functionality and data throughput to be evaluated.</p>
7	Transmitter spurious and noise	5.6	Measurement of transmit power level, and noise and spurious generated	<p>The data recorded will allow an assessment of the likely power, noise and spurious generated by one SM HAN, and (in aggregate) of multiple SM HANs operating in close proximity.</p>
8	HAN co-existence	5.6	Technical tests to simulate coexistence with: (a) Other SM HANs in	<p>This is a 'Good Neighbour' test, verifying that the solution does not materially affect other networks.</p> <p>Tests will be conducted to assess the impact of:</p>

Proposed test	Test	Evaluation Criteria Ref.	Proposed Tests	Notes
			neighbouring properties (b) Other HANs or other networks operating within premises	(a) Multiple networks for the technology being tested within range of one another (b) The SM HAN on possible 'victim' devices or networks in the operational band (e.g. the effect of the SM HAN on an active Wi-Fi network)
9	Support for upgrades of SM HAN firmware	7.1	Perform 'over the air' software update and ensure device communicates and functions correctly after update has been completed.	Principally a software test but performed using both the 'Nominal' and 'Challenging' radio environments to verify robust operation in real-life environments.

Appendix D: Events Table

1.34. The list is not a complete list, it is merely indicative, given the status and spirit of the requirements at the time of writing.

1.35. The table provides an early suggestion of events that Smart Metering System components will recognise and act on.

1.36. The list is subject to change there will need to be a process for relevant parties to add and delete and amend so that the list accurately represents the abilities of the Smart Metering System components to respond to events. The list will change over time in any case as new abilities are introduced.

1.37. It is also worth noting that the items on the list are specific to particular Smart Metering System components and some may be specific to manufacturer, version, model or technology.

1.38. The table does not currently attempt to define the actions taken as a result of events

1.39. These may include:

- logging the event
- capturing additional data
- sending messages within the Smart Metering System or remotely
- taking some physical action.

1.40. The events table currently includes the following Columns:

- Event Code - A unique reference for events to be distinguished
- Event name - A suggested name for an event
- Event description - Clarification of what the event is
- Event source - The component of the Smart Metering System that would detect the event and would be responsible for initiating actions.
- Designated Party - The party that would expect to set the configuration and expect to receive alerts that result
- Event category - A categorisation of event types
- Data items to be included - Suggests data items that might be in the specification

- Threshold level - Suggests whether different settings can be used
- Configuration items - Additional information
- Comments (freeform) - Additional comments
- ESoDR Ref - Used to add some references to ESoDR requirements.

Event Definition	Event Source	Designated Party	Event Category	Data items to be included	Threshold level	Configuration items
	Electricity Meter	DCC	Operating Condition	List of key stored parameters	Value	
Requirements	Gas meter	Supplier	PPM		Value	
DI.1.10 The SMS shall respond to the events specified in the Event Definition Table (which is included in Appendix X) in accordance to the configurable rules in the list.	Electricity & gas meter	Network	Quality of Supply			
	HAN Module	Supplier & Network	Tamper event			
	Communications Hub	Other?	Threshold			
	Gas and Electricity Meter, and Communications Hub		Fault			

Note to reader/reviewer - *The list below is not a complete list, it is merely an indicative list, given the status and spirit of the requirements at the time of writing. The list is subject to change, the list is subject to manufacturers/suppliers adding and deleting to this list so that the final SMS implementation is accurate, consistent and implemented cost effectively.*

Event Code	Event Name	Event Description	Event Source	Designated Party	Event Category	Data items to be included	Threshold level	Configuration items	Comments (Freeform)	ESoDR ref
1	Under Voltage detected Stage 1	Indicates that the Elec Meter has detected voltage levels on one phase that are lower than configured voltage thresholds	Electricity Meter	Network	Quality of Supply	Voltage, Voltage, Connection e.g. L1, L2, L3 (these need to be added to data items and data dictionary)	Configurable Between 50 and 230volts	Voltage & persistence time	Two thresholds levels are required to ensure that the event is not triggered for a loss of supply. The event occurs when the 30min mean rms voltage falls below the under voltage threshold (XX Volts) for YY half hourly periods in a defined period (ZZ days) i.e. to indicate longer term changes.	ES10, ES12
2	Over Voltage detected Stage 1	Indicates that the Elec Meter has detected voltage levels on one phase that are higher than configured voltage thresholds	Electricity Meter	Network	Quality of Supply	Voltage, Phase Voltage, Connection e.g. L1, L2, L3 (these need to be added to data items and data dictionary)	Configurable above 230 volts.	Voltage & persistence time	Two thresholds levels are required to ensure that the event is not triggered for a loss of supply. The event occurs when the 30min mean rms voltage is above the under voltage threshold (XX Volts) for YY half hourly periods in a defined period (ZZ days) i.e. to indicate longer term changes.	ES10, ES12
3	Under Voltage detected Stage 2	Indicates that the Electricity Meter has detected a voltage level on one or more of its phases that is lower than the configured voltage	Electricity Meter	Network	Quality of Supply	Voltage, Phase Voltage, Connection e.g. L1, L2, L3 (these need to be added to data items and data	Configurable between 50 and 230 volts	Voltage & persistence time	Two thresholds levels are required to ensure that the meter contactor is not opened in the event of a loss of supply (if so configured). The event occurs when therms voltage falls	ES10, ES12

Event Code	Event Name	Event Description	Event Source	Designated Party	Event Category	Data items to be included	Threshold level	Configuration items	Comments (Freeform)	ESoDR ref
		threshold				dictionary)			below the under voltage threshold (XX Volts) but exceeds a lower voltage threshold of (X'X' Volts) for ZZ seconds	
4	Over Voltage detected Stage 2	Indicates that the Elec Meter has detected voltage levels on one phase that are higher than configured voltage thresholds	Electricity Meter	Network	Quality of Supply	Voltage, Voltage, Connection e.g. L1, L2, L3 (these need to be added to data items and data dictionary)	Configurable above 230 volts.	Voltage & persistence time	Two thresholds levels are required to ensure that the meter contactor is not opened in the event of a loss of supply (if so configured). The event occurs when therms voltage fis above the under voltage threshold (XX Volts) but exceeds a lower voltage threshold of (X'X' Volts) for ZZ seconds	ES10, ES12
5	Voltage returned to Normal Limits	Indicates that the Elec Meter has detected that voltage levels have returned to a level within the configurable thresholds	Electricity Meter	Network	Quality of Supply	Voltage, Voltage, Connection e.g. L1, L2, L3 (these need to be added to data items and data dictionary)	Configurable between 216 and 253 volts	Voltage & persistence time	Voltage to be within normal tolerances for a reasonable period. This marks the end of the voltage outside limit event	ES10, ES12
6	Incoming Supply Failure [Last Gasp] (per phase)	Indicates that one phase of the incoming supply has been lower than the configured threshold and that supply is	Electricity Meter	Network	Quality of Supply	phase Voltage, Connection e.g. L1, L2, L3 (these need to be added to data items	Voltage below 180V for more than 180s. See OP3	Voltage & persistence time	Voltage to be below low voltage threshold for a min of 3 minutes before Last Gasp alarm is sent.	OP3

Event Code	Event Name	Event Description	Event Source	Designated Party	Event Category	Data items to be included	Threshold level	Configuration items	Comments (Freeform)	ESoDR ref
		considered to be 'off'				and data dictionary)				
7	Incoming Supply Failure Restored	Indicates that the Elec Meter has detected that the Incoming Supply has been Restored following an Incoming Supply Failure	Electricity Meter	Network	Quality of Supply	Date, Time of supply interruption and date ,time subsequent restoration	Configurable e.g. between 253V and 216V with the voltage condition persisting for a configurable period e.g. between 1 and 300s. See OP3.	Voltage & persistence time	Event is the loss of supply and subsequent restoration, with both sub-events time stamped. Not Last Gasp.	OP3
8	Voltage Swell detected	Indicates that the Elec Meter has detected voltage levels that are higher than configured voltage thresholds	Electricity Meter	Network	Quality of Supply	phase Voltage, Connection e.g. L1, L2, L3 (these need to be added to data items and data dictionary)	Configurable above 230 volts. See ES10.	Voltage & persistence time	The event occurs when the rms voltage exceeds a high voltage threshold (XX Volts) for ZZ second	ES10
9	Voltage Sag detected	Indicates that the Elec Meter has detected voltage levels that are lower than configured voltage thresholds	Electricity Meter	Network	Quality of Supply	phase Voltage, Connection e.g. L1, L2, L3 (these need to be added to data items and data dictionary)	Configurable between 50 and 230 volts	Voltage & persistence time	The event occurs when the rms voltage falls below a low voltage threshold (XX Volts) for ZZ second	ES10
10	Supply Disabled	Indicates that the Elec Meter has been disabled i.e. the	Electricity	Supplier & Network	Operating Condition		N/A			ES1

Event Code	Event Name	Event Description	Event Source	Designated Party	Event Category	Data items to be included	Threshold level	Configuration items	Comments (Freeform)	ESoDR ref
		contactor opened	Meter							
11	Supply Restored	Indicates that the supply has been restored i.e. the contactor is closed	Electricity Meter	Supplier & Network	Operating Condition		N/A			ES1
12	Supplier Maximum Demand exceeded	Indicates that Maximum Demand register has reached / exceeded the maximum configured level within the configured time period	Electricity Meter	Supplier & Network	Threshold	MD value (KWh), Time period	20kW	Threshold levels		PC.08 pt1
13	Maximum Demand in a 30 min period exceeds threshold	Indicates that the Elec Meter has detected a threshold that has been exceeded - this could lead to the supply being disabled.	Electricity Meter	Supplier	Threshold	Demand value	Configurable e.g. kW demand exceeds 10kW in a 30min period	Demand, Time		DI.02
14	Energy Limiting Threshold kWh over a definable period	The kWh consumption over a definable period has exceeded the threshold set	Electricity Meter	Supplier	Threshold	Consumption	Configurable e.g. kWh consumption exceeds 2kWh in a 30min period	Consumption, Time		DI.03
15	Reactive power threshold, kVAR over a 30	Indicates that the Elec Meter has detected a threshold has	Electricity Meter	Supplier & Network	Threshold	Demand value	Configurable e.g. kW demand (averaged over 60s)	Demand, Time		DI.03

Event Code	Event Name	Event Description	Event Source	Designated Party	Event Category	Data items to be included	Threshold level	Configuration items	Comments (Freeform)	ESoDR ref
	min period	been exceeded.					exceeds 10kW in a 30sec period			
16	Energy and Consumption returned to below Threshold limits	Indicates that the Max Demands / Consumption measured by the Elec Meter has reduced to a level below the threshold	Electricity Meter	Supplier & Network	Threshold	N/A	N/A			DI.04
17	Auxiliary contactor # x closed	Indicates that an internal or external contactor activated via the SMHAN has opened	Electricity Meter	Supplier & Network	Operating Condition	Aux switch ref	N/A			ES13
18	Auxiliary contactor # x open	Indicates that an internal or external contactor activated via the SMHAN has closed	Electricity Meter	Supplier & Network	Operating Condition	Aux switch ref	N/A			ES13
19	Supply Disabled (Valve Status)	Indicates that the Gas Meter has been disabled .i.e. valve closed	Gas Meter	Supplier & Network	Operating Condition	Valve status	N/A			
20	Supply Restored (Valve Status)	Indicates that the Gas Meter has been enabled i.e. valve opened	Gas Meter	Supplier & Network	Operating Condition	Valve status	N/A			
21	Measurement firmware	On command, the calculated flying checksum of the	Elec & Gas	Supplier	Tamper event	Meter type				

Event Code	Event Name	Event Description	Event Source	Designated Party	Event Category	Data items to be included	Threshold level	Configuration items	Comments (Freeform)	ESoDR ref
	error	measurement firmware is not equal to the stored checksum.	Meter							
22	Strong DC field detected	Indicates that a strong magnetic DC field has been detected.	Elec & Gas Meter	Supplier	Tamper event	Magnetic Fraud event	300 Gauss			
23	No strong DC field anymore	Indicates that the strong magnetic DC field has disappeared.	Elec & Gas Meter	Supplier	Tamper event	Magnetic Fraud event				
24	An incorrect PIN/PAS SWORD has been used more than 'x' times in sequence	Indicates that a user tried to gain access with a wrong password / PIN.	Elec & Gas Meter	Supplier	Tamper event	PIN retry level	No of retries			
25	Communication error SMHAN	Indicates a communication problem with the SMHAN components.	Communications Hub	Supplier	Fault	Meter type				
26	Communication ok again SMHAN	Indicates that the communication with the SMHAN components is ok again.	Communications Hub	Supplier	Fault	Meter type				
27	Communication error WAN communi	Indicates a communication problem with	Communications Hub	Supplier	Threshold	WAN fail event				

Event Code	Event Name	Event Description	Event Source	Designated Party	Event Category	Data items to be included	Threshold level	Configuration items	Comments (Freeform)	ESoDR ref
	cations	the WAN								
28	Communication with WAN is Ok with Communications	Indicates that the communication with the WAN is restored.	Communications Hub	Supplier	Threshold	WAN fail event				
29	Daylight saving time enabled	Indicates the regular change from GMT/UST to daylight saving time.	Gas and Elec Meter, and Communications Hub	Supplier	Threshold	Daylight saving update event				
30	Clock Synchronisation out of limits	Indicates that smart metering system is out of tolerance with Head-end system/DCC	Gas and Elec Meter, and Communications Hub	Supplier	Threshold	Clock synchronisation error, device type	Time tolerance (seconds out of sync)	Threshold levels		DS.05
31	Clock adjusted (old date/time)	Indicates that the clock has been adjusted. The date/time that is stored in the event log is the old date/time before adjusting the clock.	Gas and Elec Meter, and Communications Hub	Supplier	Threshold	Clock Time and date				OP.05
32	Clock adjusted (new date/time)	Indicates that the clock has been adjusted. The date/time that is stored in the event log is the new	Gas and Elec Meter, and Communication	Supplier	Threshold	Clock adjustment event, adjustment amount				OP.05, DS.05

Event Code	Event Name	Event Description	Event Source	Designated Party	Event Category	Data items to be included	Threshold level	Configuration items	Comments (Freeform)	ESoDR ref
		date/time after adjusting the clock.	s Hub							
33	Clock invalid	Indicates that clock may be invalid, i.e. if the power reserve of the clock has exhausted. It is set at power up.	Gas and Elec Meter, and Communications Hub	Supplier	Threshold	Clock invalid event				
34	Power down	Indicates a complete power down of a SMHAN component.	Gas and Elec Meter, and Communications Hub	Supplier	Operating Condition	Component Identifier, Power down identifier	Appropriate to device	Threshold levels		
35	Watchdog error	Indicates a watch dog reset or a hardware reset of the microcontroller.	Elec & Gas Meter	Supplier	Operating Condition	Watch dog reset	N/A			S.SMM .9
36	Firmware ready for activation	Indicates that the new firmware has been successfully downloaded and verified, i.e. it is ready for activation	Gas and Elec Meter, and Communications Hub	Supplier	Operating Condition	Firmware ready identifier	N/A			IM.02
37	Firmware activated	Indicates that a new firmware has been activated	Gas and Elec Meter, and Communication	Supplier	Operating Condition	Firmware activated identifier	N/A			IM.02

Event Code	Event Name	Event Description	Event Source	Designated Party	Event Category	Data items to be included	Threshold level	Configuration items	Comments (Freeform)	ESoDR ref
			s Hub							
38	Terminal cover removed	Indicates that the terminal cover has been removed. Could be an indication of tamper	Electricity Meter	Supplier	Tamper Alert	Terminal cover open tamper alert	N/A			S.SMM .9
39	Terminal cover closed	Indicates that the terminal cover has been closed. Could be an indication of tamper	Electricity Meter	Supplier	Tamper Alert	Terminal cover closed tamper alert	N/A			S.SMM .9
40	Meter cover removed	Indicates that the meter cover has been removed. Could be an indication of tamper	Elec & Gas Meter	Supplier	Tamper Alert	Cover removal tamper alert	N/A			S.SMM .9
41	Meter cover closed	Indicates that the meter cover has been closed. Could be an indication of tamper.	Elec & Gas Meter	Supplier	Tamper Alert	Cover Closed tamper alert	N/A			S.SMM .9
42	Interruption device failure	Indicates the interruption device has failed. Current or gas flow is measured even though the switch/valve should have disconnected the supply.	Elec & Gas Meter	Supplier	Operating Condition	Meter type				ES.1
43	Communications Validation	Communications Message received has	Gas and Elec Meter,	Supplier	Communication Faults	Communications (communications cyclic	N/A			S.SMM .3

Event Code	Event Name	Event Description	Event Source	Designated Party	Event Category	Data items to be included	Threshold level	Configuration items	Comments (Freeform)	ESoDR ref
	n Failed	failed validation	and Communications Hub			redundancy check or similar) failure				
44	Emergency Credit Limit Exceeded	Indicates that Supplier Credit Limits have been reached / exceeded	Elec & Gas Meter	Supplier	PPM	Emergency Credit	£s or Euros			PC.03
45	Debt / Credit Addition	Indicates that Supplier Debt / Credit has been loaded to smart metering system	Elec & Gas Meter	Supplier	PPM	Total debt amount by type, credit top up acknowledgment	N/A			PC.04
46	SMHAN Device Joined	Indicates that a specified SMHAN device has joined the SMHAN network	Communications Hub	Supplier	Operating Condition	Device joined flag and device identifier	N/A			HA.02
47	SMHAN Device left	Indicates that a specified SMHAN device has left the SMHAN network	Communications Hub	Supplier	Operating Condition	Device left flag and device identifier	N/A			HA.02
48	Invalid WAN Message	Indicates that the communications Hub has received an invalid message (invalid encryption of data format)	Communications Hub	Supplier	Communication Faults	Rejection message from communications Hub.	N/A			S.SMM.3
49	Local Communications	Indicates that an authorised party has accessed the	Gas and Elec Meter,	Supplier	Communication	Local access flag, device	N/A			

Event Code	Event Name	Event Description	Event Source	Designated Party	Event Category	Data items to be included	Threshold level	Configuration items	Comments (Freeform)	ESoDR ref
	access	smart metering system via a local SMHAN device that is not normally part of the SMS. (e.g. via a HHT)	and Communication s Hub		Faults	ID.				
50	Meter Mode Changed	Indicates that one or more of the meters modes has been changed	Elec & Gas Meter	Supplier	Operating Condition	Pre-pay mode flag, Credit mode flag, meter type	N/A			PC.01
51	Reverted to Factory Settings	Indicates that the smart metering system has reverted to the initial factory settings.	Gas and Elec Meter, and Communication s Hub	Supplier	Operating Condition	Factory settings flag	N/A			PC.06
52	Shutdown Reboot	Indicates that a smart metering system device has performed a controlled re-boot	Gas and Elec Meter, and Communication s Hub	Supplier	Operating Condition	Re-boot flag, device ID	N/A			
53	Unexpected reboot	Indicates that that a smart metering system device has performed an unexpected reboot	Gas and Elec Meter, and Communication s Hub	Supplier	Operating Condition	Unexpected Re-boot flag, device ID	N/A			
54	Local data / log	Authorised local access has resulted in the	Gas and Elec	Supplier	Operating Condition	Data specific flag/Device	N/A			IN.03

Event Code	Event Name	Event Description	Event Source	Designated Party	Event Category	Data items to be included	Threshold level	Configuration items	Comments (Freeform)	ESoDR ref
	download	manual download of smart metering system data	Meter, and Communications Hub			ID				
55	Low Credit Warning	The smart metering system prepayment balance has reached xxx (supplier configurable)	Elec & Gas Meter	Supplier	PPM	Credit balance, fuel type	£s or Euros	Threshold levels		
56	Emergency Credit Selected	The consumer has accepted Emergency Credit at a defined low credit threshold >£00.00	Elec & Gas Meter	Supplier	PPM	E-credit enabled, fuel type	Normally Zero Credit	load switch or Valve		PC.03
57	New log/threshold configuration set	A configuration change to the event logs has taken place	Elec & Gas Meter	Supplier	Operating Condition	Configuration flag , device I.D	N/A			DI.02
58	Debt values reconfigured	A reconfiguration of debt collection method or debt type	Elec & Gas Meter	Supplier	PPM	Debt payment attributes				PC.04
59	UTRN entered more than once	Rejected UTRN due to duplication of a recent transaction	Elec & Gas Meter	Supplier	PPM	UTRN with reason	N/A			PC.10
61	UTRN successful	Accepted UTRN	Electricity Meter	Supplier	PPM	UTRN shall be logged	N/A			PC.10

Event Code	Event Name	Event Description	Event Source	Designated Party	Event Category	Data items to be included	Threshold level	Configuration items	Comments (Freeform)	ESoDR ref
62	Uncontrolled flow of gas detected	After consumer has pressed the supply restoration button the meter sensor detects uncontrolled flow of gas and so closes the valve again	Gas Meter	Supplier	Operating Condition	Action Description, Valve Flow Message	N/A			GS.10
63	Gas 6 minute sampling started	Gas meter logs the start of recording gas interval data at 6 minute intervals	Gas Meter	Supplier & Network	Operating Condition	Sample start flag	N/A			GS.04
64	Gas 6 minute sampling ceased	Gas meter logs the end of recording gas interval data at 6 minute intervals	Gas Meter	Supplier & Network	Operating Condition	Sample end flag	N/A			GS.04
65	UTRN rejected	Rejected UTRN for any reason	Elec & Gas Meter	Supplier	PPM	UTRN with reason	N/A			PC.10
66	UTRN successful	Accepted UTRN	Electricity Meter	Supplier	PPM	UTRN shall be logged	N/A			PC.10
70	Self-disablement	The supply is interrupted as a result of prepayment/PAYG rules and thresholds	Elec & Gas Meter	Supplier	PPM	Prepayment/PAYG disablement flag, meter balance, register readings, debt settings	Configurable - meter balance equals or is below threshold set in £s or Euros to trigger event			PC.03

Event Code	Event Name	Event Description	Event Source	Designated Party	Event Category	Data items to be included	Threshold level	Configuration items	Comments (Freeform)	ESoDR ref
71	Self-enablement	When the supply has been disabled due to insufficient credit, when the meter balance reaches the supplier set threshold the supply is armed and made ready for local activation.	Elec & Gas Meter	Supplier	PPM	Prepayment/PAYG enablement flag, meter balance	Configurable - meter balance equals or is above threshold set in £s or Euros to trigger event	Threshold, visual alerts (configurable message to be displayed on meter up to 32 characters long), audible alert provision, On/Off		PC.03, OP.8, PC.10, PC.11
72	Manual Input of UTRN suspended	There has been a number of consecutive failed attempts to manually enter a UTRN within a defined period and, for security reasons, the meter suspends (time-out) the capability to manually enter UTRNs for a defined period.	Elec & Gas Meter	Supplier	PPM	Manual UTRN entry suspended, meter balance, supply status (on, armed, PAYG disabled)	x' number of consecutive entry failures in 'y' minutes.	Number of consecutive failed attempts, period over which the failures have occurred, visual alert (configurable message to be displayed on meter up to 32 characters long), audible alert.		PC.10
73	Suspension of Manual Entry of UTRN ended	The period where the functionality to manually enter UTRNs ends and this functionality is, once again, made available at the meter.	Elec & Gas Meter	Supplier	PPM	Manual UTRN entry allowed flag, meter balance, supply status (on, armed, PAYG disabled)	Period suspension in force for 'z' minutes	Length of suspension, visual alert (configurable message to be displayed on meter up to 32 characters long), audible alert, duration of audible alert		PC.10

Event Code	Event Name	Event Description	Event Source	Designated Party	Event Category	Data items to be included	Threshold level	Configuration items	Comments (Freeform)	ESoDR ref
74	Debt collection completed	The total debt figure for a debt category has decremented to zero and the collection of repayments for that category ceases.	Elec & Gas Meter	Supplier	PPM	Debt repaid, debt category, fuel type.	N/A	visual alert (configurable message to be displayed on meter up to 32 characters long), audible alert,		PC.04
75	Load Limit Threshold Reached	The meter balance reaches the level where the load is limited.	Elec & Gas Meter	Supplier	PPM	Prepayment/PAYG load limit flag, meter balance	Configurable - meter balance equals or is below threshold set in £s or Euros to trigger event	Meter Balance Threshold, Load threshold		DI.02
77	Modification of PAYG Settings	Adjustments have been made to PAYG specific settings which would include; Meter Balance, Emergency Credit Value, Non-disconnect settings, Threshold values	Elec & Gas Meter	Supplier	PPM	Prepayment/PAYG settings changed, description of the setting changed, old value of setting	N/A	N/A		PC.03, PC.01, PC.11
78	Supply Restored	Following the arming of the supply the process to restore the supply has been successfully completed.	Elec & Gas Meter	Supplier	PPM	Supply restored, meter balance, debt settings	N/A	N/A		OP.8, PC.11
79	Consumer Set Low Credit	The meter balance has reached the	Elec & Gas	Supplier	PPM	Consumer low credit level	Configurable - meter balance	Threshold, visual alert (configurable		PC.03

Event Code	Event Name	Event Description	Event Source	Designated Party	Event Category	Data items to be included	Threshold level	Configuration items	Comments (Freeform)	ESoDR ref
	Warning	consumer set threshold where an audible and visual reminder is provided to remind them that a top-up is required	Meter			reached, visual alarm provided Y/N, audible alarm provided Y/N	equals or is below threshold set in £s or Euros to trigger event	message to be displayed on meter up to 32 characters long), audible alert provision, On/Off		
80	Emergency Credit Available for Selection	The meter balance has reached the supplier set threshold where emergency credit is made available for selection	Elec & Gas Meter	Supplier	PPM	Emergency Credit available, meter balance	Configurable - meter balance equals or is below threshold set in £s or Euros to trigger event	Threshold, visual alert (configurable message to be displayed on meter up to 32 characters long), audible alert provision, On/Off		PC.03
83	Remote Payment Application/Meter Balance Adjustment	Indicates that a remote message has been received which has resulted in a change to the meter balance.	Elec & Gas Meter	Supplier	PPM	Payment/Adjustment Value, UTRN (if applicable), Supplier Adjustment Flag (if applicable), Meter Balance prior to application of adjustment, Register Readings, Deductions for Debt, Debt Settings	N/A	N/A		PC.11

Event Code	Event Name	Event Description	Event Source	Designated Party	Event Category	Data items to be included	Threshold level	Configuration items	Comments (Freeform)	ESoDR ref
85	Consumer PIN/password entry suspended	Indicates that a user tried to gain access with a wrong password / PIN. Only applicable if this function is used by the manufacturer for privacy purposes.	Elec & Gas Meter	Supplier	PPM	PIN/password entry suspension flag	Number of consecutive invalid PIN entries, period over which the consecutive invalid entries must be made	Number of consecutive invalid PIN entries, period over which the consecutive invalid entries must be made, configurable visual alert, audible alert, on/off,		
86	Consumer PIN/password entry suspension lifted	Indicates that the suspension period for PIN entry has expired and the function to enter the PIN has been made available again.	Elec & Gas Meter	Supplier	PPM	PIN/password entry suspension lifted flag	Length of suspension period	Length of suspension period, configurable visual alert, audible alert, on/off,		